

---

This is a reproduction of a library book that was digitized by Google as part of an ongoing effort to preserve the information in books and make it universally accessible.

Google™ books

<https://books.google.com>

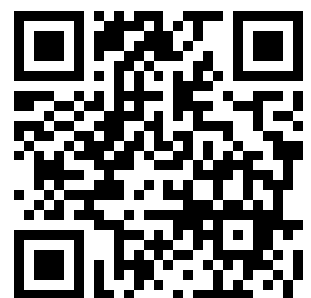

NYPL RESEARCH LIBRARIES



3 3433 09076076 4



American  
KNG







*Index in lost one*

11/16

# AMERICAN BLACKSMITH

A Practical Journal of Blacksmithing and Wagonmaking

BUFFALO  
N.Y., U.S.A.

OCTOBER, 1916

778836

\$1.00 A YEAR  
10c. A COPY

## THE WELDED TOOL STEEL CENTER

is not the only reason why

### YOU SHOULD USE ONLY ROWE CALKS

*V 11/16*



but there are many other good and sound points in favor of your doing so.

#### QUALITY, FINISH, COUPONS, PROTECTION

all of these things are more or less familiar to you in connection with Rowe Calks, but



HERE IS SOMETHING WHICH YOU WANT TO THINK OVER

### WE ADVERTISE FOR YOU

*val 11  
oct 1916  
Sep 1916  
to*

It is to Your Advantage to Handle Advertised Goods.

THEY ARE EASY TO SELL. When a customer enters your shop he already knows all about Rowe Calks and he will gladly follow your suggestion to have his horse shod with them.

ROWE CALKS MEAN BIGGER PROFITS, because they are easy to sell and you therefore sell a good many more of them.

ROWE CALKS STAY SOLD because they give satisfaction and they make your customer come back to your shop for more. If you are out of them he will go elsewhere.

ROWE CALKS ARE GUARANTEED and we stand back of the guarantee.

Write us Today and we shall be glad to tell you how we help you advertise your business.



## The Rowe Calk Company

Plantsville, Connecticut

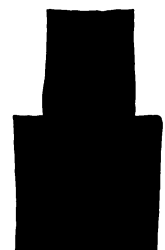

*ly*





**EMCO**

**Malleable Iron Castings**

for

**Carriages, Wagons**

**and Automobiles**

**The Eberhard Manufacturing Co.**

**Cleveland, Ohio**



# TIMELY TALKS WITH OUR SUBSCRIBERS

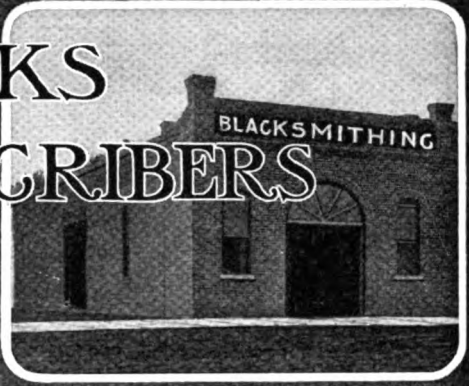

The American Blacksmith is published monthly at The New Sidway Building, Buffalo, N. Y., U. S. A., by The American Blacksmith Company, incorporated under New York State Laws. Entered, February 12, 1902, as second-class mail matter at Buffalo, N. Y., Act of Congress, March 3, 1879.

William F. Wendt, President      Albert W. Bayard, Secretary      Walter O. Bernhardt, Editor  
Associates: James Cran      Bert Hillyer      A. C. Gough      Dr. Jack Seiter

Subscription Price: \$1.00 per year in advance, prepaid to any postoffice in United States or Mexico. To Canada, \$1.25; other countries, 6 shillings. Reduced rates to clubs of five or more on application. See "Honor Roll" page for money-saving, long-time rates. Cable address, "Blacksmith," Buffalo. Lieber's Code used.

Subscribers should notify us promptly of non-receipt of paper or change of address. In the latter case it is necessary that you give us both the old and the new address.

## THE NEW VOLUME

With this number begins the sixteenth volume of THE AMERICAN BLACKSMITH and for this volume we are planning still further improvement, still bigger things, still better features.

We will continue in our policy of securing the authorities as writers and contributors to our papers—the men who can really give our readers the real worth while information in their respective fields. Consider for example our present list of contributors: Messrs. Page, Hillyer, Cran, Steelman, Buckley, Seiter, Pope, Shaw, and many others who need no introduction to "Our Folks". The information contained in the practical articles that they have spread before you in these pages, is sufficient proof of their "weight" as practical writers and authorities.

And the articles that we have published on Horseshoeing, Automobile Repairing, Oxy-Acetylene Welding and Cutting, Steel and Steel Working, Vehicle Repairing, Plow and Implement Work, General Forging, etc., is sufficient to show the kind and grade of articles that may be expected for our readers during the next year.

When you have gone through this paper carefully, let us know frankly whether or not we have met your ideas as to how a blacksmith paper should be published and edited. Tell us if we are giving you the information you are looking for; let us know if THE AMERICAN BLACKSMITH is filling your needs, wants and requirements.

### Subscription Agents

When a stranger solicits your subscription to THE AMERICAN BLACKSMITH or any other publication, insist upon him showing you absolute proof that he is an agent in good standing and is employed by the publication which he represents. Don't under any circumstances give the man your money if you are not sure that he really works for the paper he says he does. No matter what the man offers you—no matter what price he makes—no matter what premium he promises to send—Don't Give Him Your Money If You Are Not Sure.

Contents, October, 1916

The Fishing is Good If Frontispiece.....	9
A Non-Oxidizing Electric Furnace.....	10
Some Suggestions for Discontented Partners .....	10
The Horseshoer .....	11
Shoeing the Ankle Hitter .....	11
British Shoeing Smiths and the War Thoughts on Timely Topics.....	12
The Smith in The Daily News .....	13
Child Killed by Smith's Tongue....	13
Smith Hurls Barrel Through Window Wants Anvil as Monument .....	13
Strong Smith Helps Lazy Man ....	13
Aurora Shoers Raise Prices .....	13
Original Remington Anvil.....	13
Wagon Gone—Blacksmith Sued....	13
Fall—The Blacksmith's Season—Verse Heats, Sparks, Welds.....	14
Our Honor Roll .....	15
Fundamentals of Lath Practice.....	16
Gas Engine Operation Made Simple—2	18
Smith Work on a Whaling Ship.....	20
Illinois Blacksmiths Pull Unique Stunt .. .....	21
Benton's Receipt Book .....	22
To Clean the Radiator .....	22
A Brass Polish .....	22
An Ordinary Saw Will Cut Cast Iron	22
To Case Harden Steel .....	22
Compound for Welding .....	22
A Cement for Marble.....	22
To Temper Coil Springs .....	22
Queries, Answers, Notes.....	22
Smithing for 37 Years.....	22
To Tighten Auto Wheel Channels..	22
A Drill Feed Improvement.....	22
Ford Wiring Diagram.....	23
An Interesting Letter from South-Africa .....	23
Competitors that Work Together..	23
Prices and Wages .....	23
From a Minnesota Smith.....	23
The Automobile Repairman.....	24
Cooling and Lubrication Troubles..	24

## MAKING THE WINTER EVENINGS PROFITABLE

Right now, on the eve of the long evening season is the time to consider how you can make these long evenings show a profit. What are you going to do? Are you going to sit around and wait for bed time, or are you going to take advantage of the opportunity presented by the long evenings of winter, and prepare for better things? Here's an excellent opportunity to brush up on your trade knowledge. Why not read and study several books on those branches of smithing on which you are rather lax. If you are undecided as to just what books you need, get in touch with our Book Department for a list of smithing craft books, or tell us what you want to study. The subjects you are interested in, and the Book Department will be glad to send you suggestions, lists and prices. If you expect to take up automobile work next spring, why not get busy now and study up on the subject? If you intend purchasing an oxy-acetylene outfit, begin right now to learn how to use this new piece of blacksmith shop equipment. Get in touch with the Book Department now, let them have your ideas and they will be glad to help you.

### THE FEATURE ARTICLE

The feature article this month is "A Non-Oxidizing Electric Furnace", by John Jernberg. This article is the first of a series by Mr. Jernberg, all of which will have more or less to do with the heat treatment of steel. In this first article Mr. Jernberg details the construction of an electric furnace which he found necessary to the successful completion of his experiments in heat treatment. In the building of this furnace Mr. Jernberg was assisted by Mr. Erick H. Fors, and by Mr. Raymond W. Burns.

Mr. Jernberg's articles are always of extreme interest, and his description of the building of this Non-Oxidizing Electric Furnace will no doubt contain much of interest and value to the tool and steel worker.



THE FISHING IS GOOD IF—

Business is a good deal like fishing; and some men are good fishermen and some are not. Any old chap who can hold a pole is not necessarily a successful fishing combination, any more than any old shack for a shop and any old equipment will do for a successful smithing business. But— an up-to-date shop with the proper service and equipment and run by a practical man will succeed just as a good boat, proper bait and a skilled fisherman will bring home a liberal share of the day's catch. Proper equipment plus service plus knowledge will land the Business.



# A Non-Oxidizing Electric Furnace

JOHN JERNBERG

Assisted by

ERIC H. FOBS AND RAYMOND W. BURNS

A great deal of discussion has been going on recently in regard to the action of a secondary heat treatment on high speed steel. Being interested in this subject we found no suitable means of properly heat treating the steel. The ordinary method of heating tools is to place the nose of the tool in the forge fire, but this requires an experienced man both in handling the fire and in judging temperatures. The next method that would suggest itself would be a gas furnace. Here, however, we en-

counter the formation of oxide on the tool, due to the introduction of air into the furnace from the air blast. To prevent this oxidation of the surface of the tool the simplest remedy is the immersion of the tool in molten salt heated in a crucible in the forge fire. Whereas a pyrometer can be used to ascertain the temperature here, nevertheless, it is practically impossible to obtain a certain temperature and hold it, and since the crucible is heated from one side only the temperature of the bath is not uniform throughout. A

combination of the gas furnace and crucible would then appear satisfactory, but very high temperatures necessary for heat treating high speed steel are made harder to obtain on account of the difficulties of conducting the heat to the bath.

The only alternative is the consideration of an electrically heated furnace.

### Statement of the Problem

A great many factors must be considered in the development of the design of an electrical hardening furnace. The practical requirements

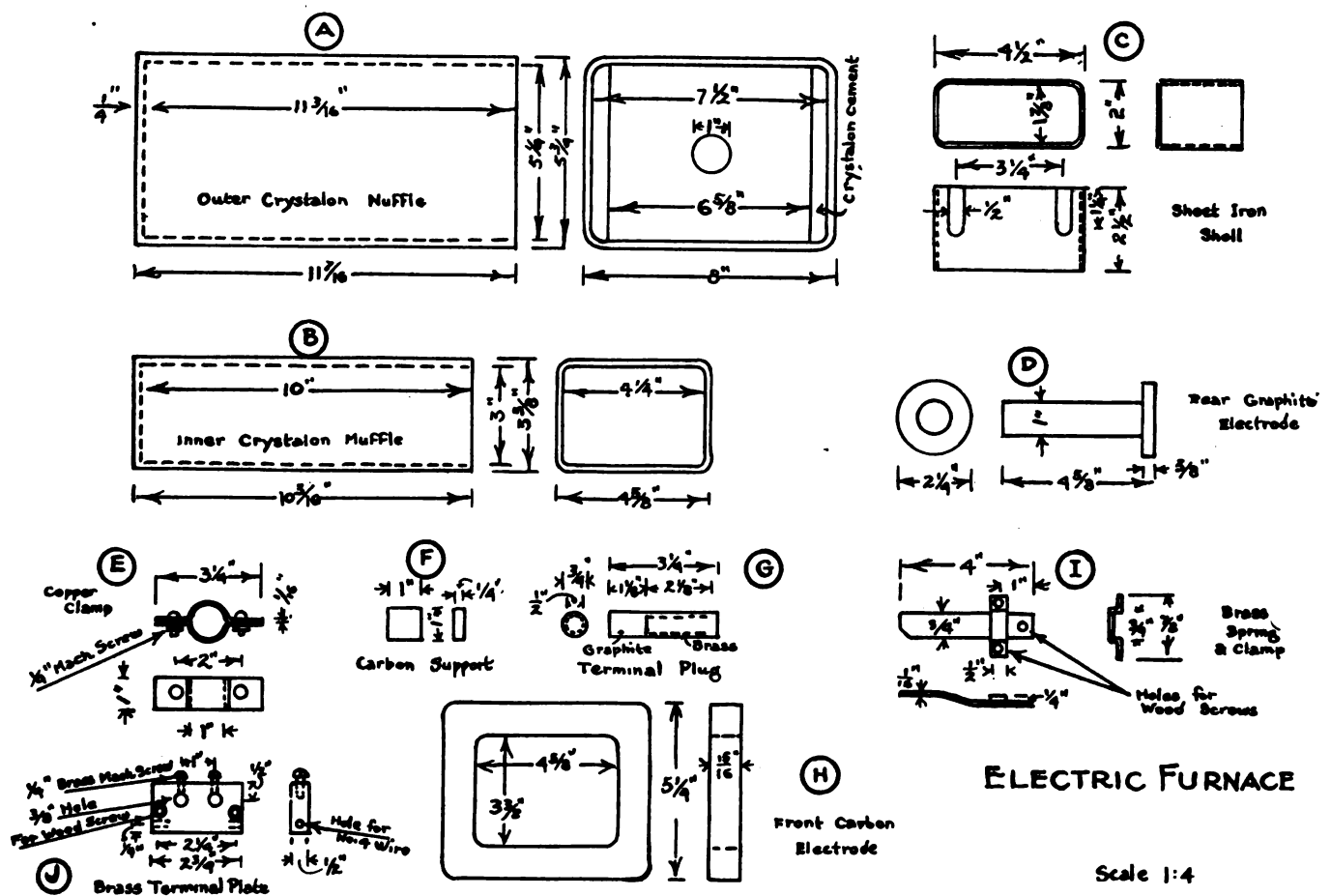

FIG. 1.—DETAILS OF THE FURNACE PARTS BEFORE ASSEMBLING, SHOWING DIMENSIONS AND SPECIFICATIONS





as to exclude any possibility of leakage of the bath. Two iron electrodes, located on opposite sides of the crucible, direct the current from the transformer through the bath. The secondary coils of the transformer are direct connected to the furnace electrodes, while the primary coils are subdivided into a number of sections, taps from which are brought to a dial switch. The necessary range in voltage at the electrodes is obtained by rotating the dial switch, thus cutting in or out of circuit parts of the primary winding. Salts used for the bath are non-conductors of current when cold, and, therefore, two or three pieces of lamp carbon are laid across the top of the salt and a current is passed through them. The current flowing generates heat in the pieces of lamp carbon and melts the surrounding salt.

This furnace has the advantage

of low cost of upkeep. When operating at 2200°F., the electrodes last from one to two weeks and the crucible lining about a year. The cost of the crucible lining is very low, as is also that of the electrode plates. The furnace has also the advantage of very little oxidation of the tool surface owing to the fact that air is excluded during the heating of the tool.

A few of the disadvantages to be enumerated are as follows:

1. It appears that tools heated for hardening in a crucible containing barium chloride have a soft scale or film of soft metal, probably .003 to .006 inches thick, all over the surface of the tool. This is unsatisfactory for tools that are not to be ground.

2. All salt mixtures suitable for steel hardening purposes melt at a temperature considerably beyond the melting point of lead, and as salt

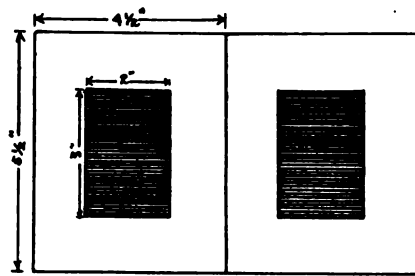

Section x-x

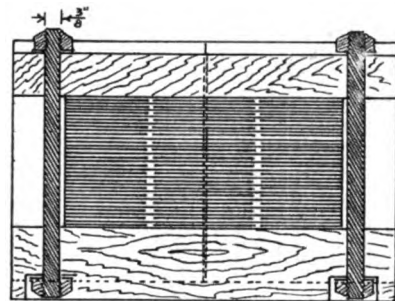

Section y-y

FIG. 4.—SHOWING SECTIONAL VIEWS OF THE TRANSFORMER CONSTRUCTION

mixtures are much worse conductors of heat, it is difficult to avoid the incrustation of frozen salts about the top of the pots.

3. Barium chloride must be very pure or at least free from sulphur compounds as those in the molten state readily attack the surface of the steel objects.

4. For temperatures up to 1300°F., a lead bath must be used. From 1300°F. to 1850°F. the bath should consist of a mixture of barium chloride and potassium chloride, the correct proportion depending upon the temperature desired. From 1850°F. to 2400°F. the bath should consist of barium chloride only. Barium chloride melts at 1580°F. This necessitates quite a little work and a great deal of awkward handling to obtain the temperature range between room temperature and 2400°F.

5. Great care must be used in the operation of the furnace. A short circuit between the electrodes through the steel to be hardened must always be avoided. Also, steel is a better electrical conductor than the bath and precautions are necessary to keep the temperature of the steel from rising above that of the bath due to the current passing through the steel even though steel does not come into contact with the electrodes. All tools of whatever shape, should always be immersed in the bath with their greatest lengths parallel to the electrodes, and the

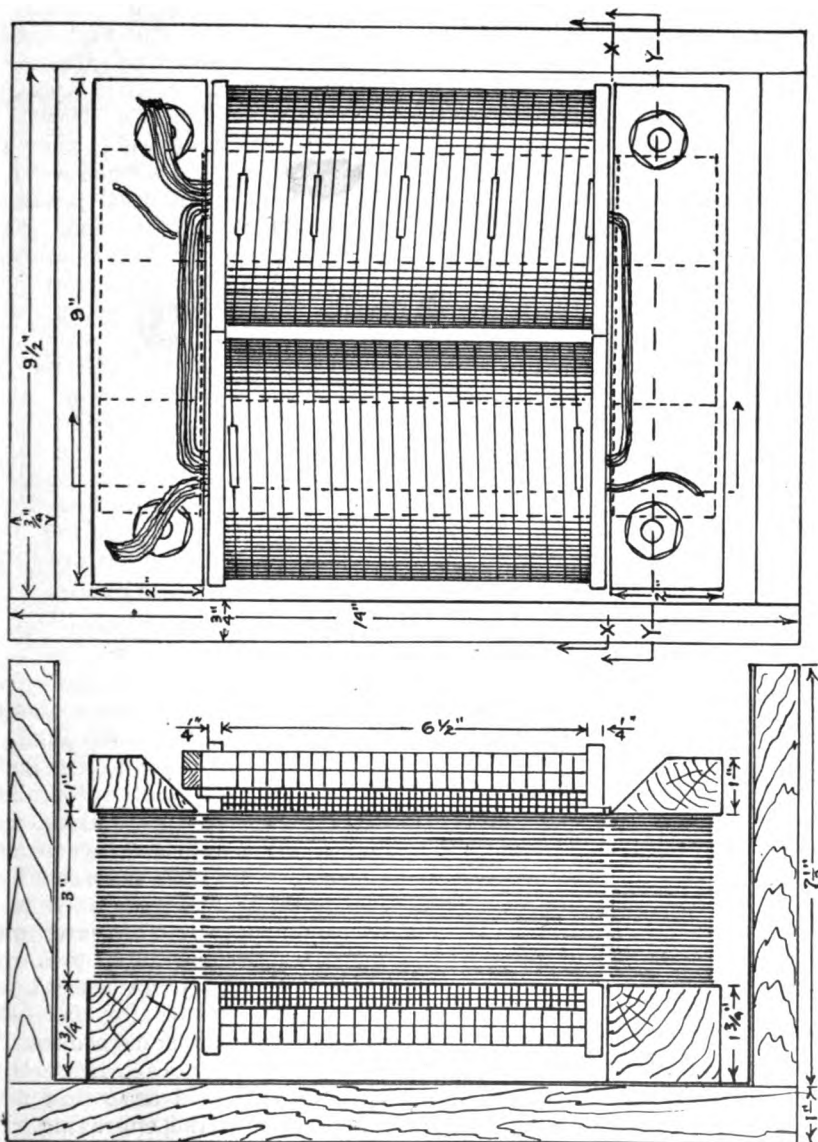

FIG. 3.—TOP AND END VIEW OF TRANSFORMER CONSTRUCTION



capacity of the bath is limited, due to this consideration alone.

6. The difficulty and awkwardness of starting the furnace is another objection.

This discussion brings out the problems to be met in the design of the electric furnace under consideration.

**Description of Materials and Methods**

In the design of our furnace we decided to avoid the barium chloride bath, if possible, principally on account of the necessity of different

could be purchased in bulk for upkeep requirements, we decided to use it in the design of this furnace.

In order to obtain a uniform temperature throughout, the furnace chamber should be entirely surrounded by the heating material. This led to the selection of an annular space surrounding the furnace chamber on all sides and filled with granulated carbon. We consulted the Norton Company as to the best refractory material to be used for our purpose and they recommended

ments for different temperatures and then design a suitable transformer for it.

As the front ends of the two muffles were open, it was necessary to provide a carbon electrode cut to such a shape as to just completely fill the annular space between the two muffles, both to uniformly distribute the current to the granulated carbon and to seal the end between the muffles.

The front electrode was made from a plate of battery carbon, 15-16-inch thick, obtained from Stuart-Howland Company, Boston, Mass.

The other electrode was introduced through a hole cut in the center of the back end of the outer muffle. The cross-section of this electrode was decided on by the current carrying capacities of difference cross-sections of graphite.

In looking up the matter of heat insulating material we found that there was material of high heat insulating properties on the market manufactured by the Kieselguhr Company of America, New York, N. Y. This material, known as "Sil-o-cel" is of extremely cellular nature, being a mineral product of highly siliceous composition and of very light weight. It is composed of numerous hollow cells and has a thermal insulating power about equal to that of cork or from ten to twelve times the insulating power of ordinary fire brick. Being almost pure silica its melting point is high, 2930°F., as reported by the Bureau of Standards, and can be subjected to high temperatures without fear of alteration. These insulating bricks cost but little more than fire brick.

**Construction of Furnace**

The method of building up the furnace was as follows:

A wooden base was made by nailing a board to three cross pieces as shown in Fig. 2. Side and end strips were attached to the bottom board to enclose the foundation layer of the heat insulating material. This foundation layer consisted of a slab of "Sil-o-cel," 2 1/4 inches thick, and was fitted to the enclosing strips. The outer muffle was then cemented on two inner sides with Crystolon cement to a depth of 1/2-inch for the whole length of the muffle as shown. The front and rear carbon electrodes were then shaped according to the sizes given in the engraving. The rear electrode was inserted in the hole in the closed end of the outer

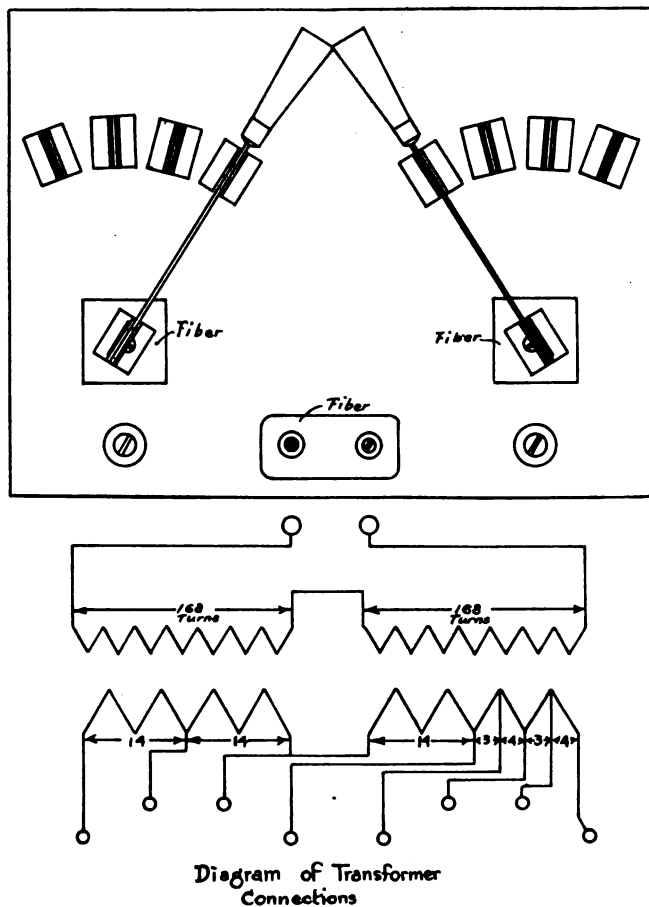

Diagram of Transformer Connections  
FIG. 5.—TOP VIEW OF THE SWITCH BOARD AND ALSO DIAGRAM OF CONNECTIONS

mixtures for different temperatures, the necessity of great care in operation and the awkwardness and difficulty in starting. The carbon resistor furnace seemed entirely satisfactory and to meet all the requirements with the exception of the cost of upkeep on account of the great deterioration of the carbon. This deterioration seemed unnecessary and almost fully avoided by enclosing the carbon resistance material with some covering to protect it from the air. On account of the high resistance of granulated carbon, the ease with which it could be made to conform to the shape of the enclosing receptacle, and the fact that it

each of rectangular cross-section with one closed end. The sizes of these were 3 by 4 1/4 by 10 inches with 3-16-inch wall and 5 1/4 by 7 1/2 by 33 3-16 inches with 1/4-inch walls. It can be seen that the annular space at the sides between these two muffles is greater than that between the bottom and top when the smaller muffle is located centrally inside the larger one. We therefore put a half-inch of crystolon cement on each side wall of the large muffle to make a uniform annular section all over.

We decided to build the furnace with this as a basis and test it in the Electrical Engineering Laboratory for current and voltage require-



muffle, the head of the electrode being on the inside of the muffle as shown. The outer muffle was then placed on end and filled to a depth of 1 inch with granulated carbon. The smaller muffle was

to give a finish. Small brass terminal plates were screwed to the front and rear end of the bottom board, as shown in the engraving. Two lengths of No. 4 copper wire were brought up from the front ter-

fore kept the voltage constant and allowed the current to increase. The current was allowed to increase to 82 amperes with this voltage. Then the voltage was dropped in order to keep the current around this value. After a run of about 2½ hours, the temperature of the furnace was fully up to 2200° F. and the final current was 90 amperes and the voltage was 25 volts as shown in table No. 1. this test gave us the data for the design of the transformer.

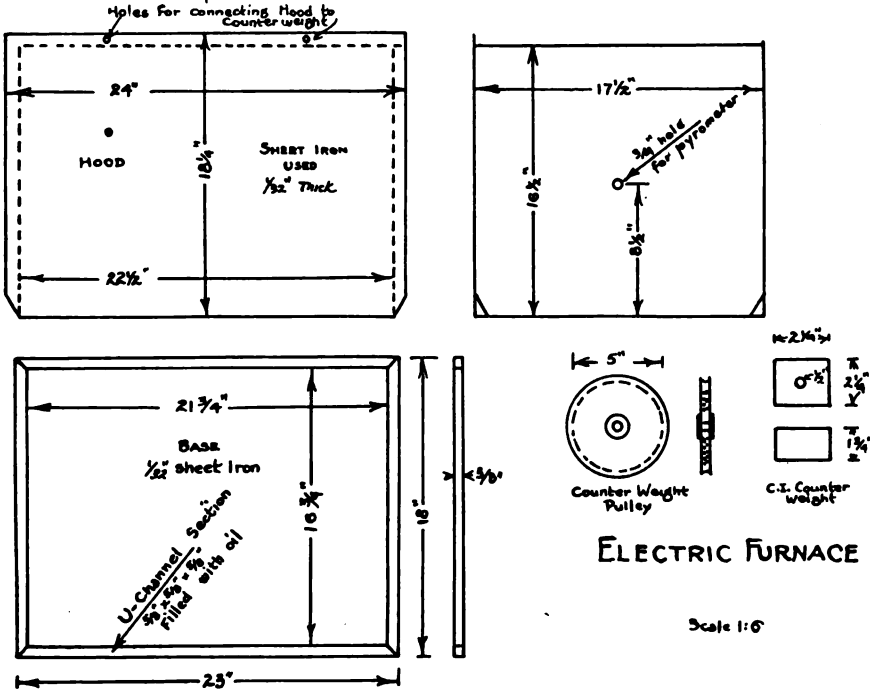

FIG. 6.—THE HOOD FOR THE FURNACE SHOWING DIMENSIONS AND FITTINGS

then set centrally inside the outer muffle and the annular space between the two muffles was filled with granulated carbon. Four small blocks of carbon, 1 inch high, were inserted between the two muffles to act as a support for the inner muffle when in the horizontal position. The front electrode just fitting and closing this annular space was then inserted. The muffles were then placed centrally on the "Sil-o-cel" foundation and slabs of "Sil-o-cel" were built up around them. The top of the outer muffle was then covered with a slab similar to the one used as the bottom foundation. An opening for the door and four holes for the front terminal plugs were cut in the front slab of "Sil-o-cel", as shown. Two wooden strips were attached to the front end, each carrying two brass springs which pressed the four terminal plugs against the front electrode. The "Sil-o-cel" slabs were firmly held in position against the outer muffle by binding them with wire passing through eyelets screwed into these front wooden uprights and into the side strips on the base board. The whole exterior was then coated to a depth of about ¾-inch with magnesia steam-pipe covering which was smoothed down

minimal plate to the brass springs, as shown. The wires were soldered to the terminal plate and also to the springs under the retaining clamp. A clamp, made of two copper strips, was formed to fit the projecting end of the rear electrode. The two screws which served to clamp the strips to the electrode also served to securely hold fast the ends of two lengths of No. 4 copper wire between the clamps. The other ends of these two lengths of copper wire were soldered to the rear terminal plate. The furnace was then complete.

Furnace Test for Transformer Design

The furnace was removed to the Electrical Engineering Laboratory where any range of current and voltage could be obtained. To obtain the low voltage necessary, we used several water barrel resistances in series with a 110-volt direct current line. The current was not allowed to exceed 25 amperes for about three hours in order to thoroughly dry out the furnace. The following day we started with the furnace cold and set the voltage between the terminals arbitrarily at 35 volts. This voltage sent 29 amperes through the furnace, using 1015 watts to start the furnace. As the carbon heated up the resistance dropped. We there-

Time	Volts	Amperes	Res. Ohms.
9.40	35	29	1.20
9.45	35	35.5	.98
9.475	35	38.5	.91
9.50	35	43	.82
9.525	35	48.5	.72
9.55	35	55.5	.63
10.00	35	65	.54
10.20	35	82	.43
10.40	31	89	.35
11.00	28.5	90	.32
11.20	27	83.5	.32
11.40	25.5	91	.28
12.00	25.5	92	.28
12.10	25	90	.28

TABLE NO. 1. Furnace Test for Transformer Design.

Transformer

The requirements for the transformer were therefore set at a maximum of 35 volts and 100 amperes, to be delivered from the secondary. A 220-volt line was obtainable in the heat treatment room and this was used as the basis for the primary winding. Since the voltage must be reduced at high temperatures as seen in the table, it was decided to obtain this reduction by subdividing the secondary into a number of sections, taps from which were to give the required voltage range. This method was used instead of having a resistance in series with the furnace with the consequent loss in power.

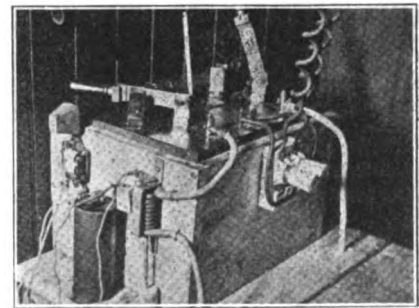

FIG. 7.—THE TRANSFORMER AND ITS FITTINGS

The construction of the transformer is of the core type, the windings being divided into two sections. The core was made up of special transformer iron stampings, .015-inch thick, varnished on one side. These were rectangular in shape and were of two sizes, 4½ by 2 inches and 6 by 2 inches, respectively. Sufficient stampings were obtained





to make two piles of each size, 3 inches high when compressed. These stampings were obtained at the W. & S. Mfg. Co., 9 Hunt St., Worcester, Mass. The longer sizes were first built up with the alternating ends

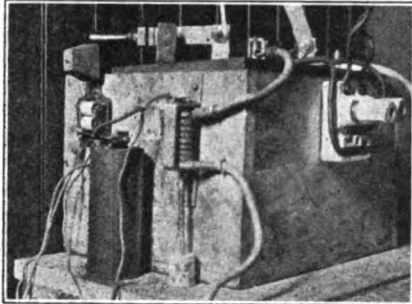

FIG. 8.— THE OVERLOAD ALARM AS ATTACHED TO THE TRANSFORMER

overlapping 2 inches until two piles three inches high when compressed were built up. Each pile was tightly clamped and wrapped with two layers of tape and then with two layers of brown paper, painted well with shellac. These made up the two long legs of the core. Four fiber heads were cut from 1/4-inch sheet to the dimensions shown in Fig. 4. Two of these heads were placed on each of the assembled legs, 6 1/2 inches apart, as shown. In order to wind the wire on the two legs, wooden end blocks were constructed which fitted over the projecting ends of the legs and were screwed to the fiber heads. The blocks were centered so that the legs could be wound in a lathe. Three layers of No. 10 D. C. C. magnet wire with 57 turns to each layer, were wound on each leg. This required ten pounds of wire. As the wire was wound it was constantly tested with a voltmeter to see that there was perfect insulation. To insure tight winding, the wire was drawn from the spool over a reel with sufficient turns on the reel to prevent slipping. The reel was supported on the bench back of the lathe by two wooden uprights. Variable friction on the reel was obtained by a wood clamp across the top of the two uprights. These windings were each wrapped with two layers of brown paper painted well with shellac. This constitutes the primary winding of the transformer.

The secondary consists of two layers of No. 4 B. & S. D. C. C. magnet wire wound double, that is, the ends of the two wires are securely soldered together and wound side by side, as if it were a single wire. One wire of No. 1 gage could be used in place

of the No. 4 wires, but the difficulty in winding warranted the use of two conductors in parallel. There are 28 single turns or 14 double turns to the layer. One-half of the total 56 turns was wound on each leg. This required 16 pounds of No. 4 wire. The conductors were tapped from the 14th, 28th, 42nd, 45th, 49th, and 52nd turns of the secondary winding. Taps were made by inserting copper strips, 1 1/4 inches square by 1-16-inch thick, between the two parallel conductors. The conductors were then bound tightly together with fine copper wire on both sides of the strips and the whole joint soldered and covered with tape.

When the second winding was finished, the two legs were set so that the windings encircled the core in the same direction. The short iron stampings were slipped into the spaces between the ends of the long iron stampings which formed the two legs. This completed the magnetic circuit of the core, and the whole thing was carefully squared up. Two clamps, as shown in the engraving, were made to hold the end strips tightly together.

The transformer was enclosed in a box lined with galvanized sheet iron, as shown in Fig. 3, and filled with transformer oil. The two primary windings were connected in series in such a way as to produce a magnetic circuit through the core in the same direction. The two secondary windings were connected in series in the same manner. The cover of the box was used as the switchboard and is shown in Fig. 5. The diagram of transformer connections shows the method of connecting the taps and terminals of the windings to the switchboard. Two 100 ampere single pole switch knives and the clipwires mounted on the cover. Each knife was so mounted that it could be swiveled around to four clips, as shown. The advantage of this method of connecting the taps

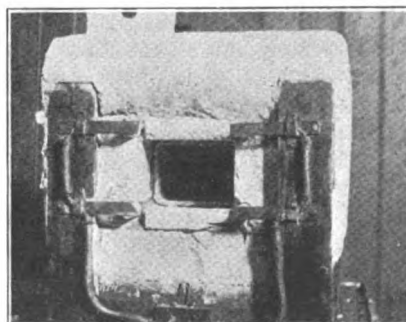

FIG. 9.—THE FURNACE FROM THE FRONT

is that it is possible to obtain 16 changes of voltage from 0 to 36 by 2 1/2 volts. Thus the very low temperatures in the furnace can also be maintained as well as the very high temperatures.

The connection between the switch knives and the secondary binding posts is made up of a sufficient number of strands of very fine copper wire to carry the current. This makes a very flexible connection.

The furnace and transformer were installed in the heat treatment room on a wooden stand. A Thompson ammeter was used to measure the primary current and a wattmeter to measure the input. A Thompson ammeter, connected to a series transformer, was used to measure the very high current flowing in the secondary winding. A thermometer was placed in the oil bath of the transformer to measure the temperature rise of the oil.

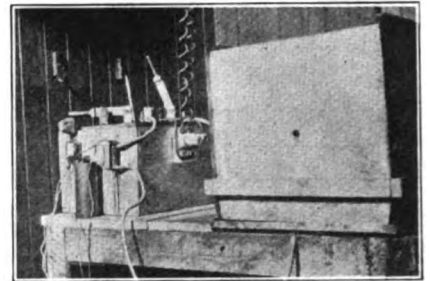

FIG. 10.—THE FURNACE HOOD, TRANSFORMER AT LEFT

The first test of the furnace lasted 2 hours and 10 minutes, and was just sufficient to raise the temperature to 2200°F. The data for this test are shown in table No. 2.

Time	Transf. Temp.	Wattmeter Input	Prim. Amperes	Sec. Amperes	Furnace Temp.
11.10	22.5°C	1.3KW	6.2	25	0°F
11.20	25.0	1.2	6.8	30	
11.30	24.2	1.8	8.2	50	
11.40	26.0	2.2	10.4	62	1100
11.50	27.5	2.8	12.0	78	1325
12.00	31.0	3.0	13.9	90	1400
12.10	34.0	2.7	11.4	85	1500
12.20	35.8	2.4	11.3	85	1700
12.30	38.5	2.4	11.5	87.5	1750
12.40	40.6	2.5	12.1	91	1825
12.50	43.0	2.6	12.6	95	1900
1.00	45.8	2.2	13.2	99	2000
1.10	48.2	2.8	13.6	102.5	2100
1.20	51.5	2.8	13.6	102.5	2200

TABLE NO. 2.  
First Test of the Furnace.

#### Conclusions from First Test

As the temperature of the furnace arose above 2000°F., we noticed a small blue flame at the mouth of the furnace, showing that the carbon was slowly combining with the air. This showed that some depreciation of the carbon was going on which we wanted to avoid as far as possible. We, therefore, decided to build an air-tight sheet metal hood (Fig. 6) to enclose the whole fur-



nance, air tight except for a hole in front for the insertion of the pyrometer and allowance for the escape of the expanding gases.

Two features are of particular interest here. The soldered joints of the hood are exposed only to the outside air, which prevents the solder from melting on account of high temperatures under the hood. The flanges resulting from this method of soldering make the construction rigid. The second feature is that the hood can be raised and lowered over the furnace and which in the lowered position is oil sealed to the base. This can be seen in the line engravings and the photographs.

The next thing we noticed was that the projecting end of the rear electrode was slowly deteriorating due to the action of the air on it, and also that considerable heat was last here. To obviate this difficulty we constructed a small tin shell to to cover the electrode and filled in around the electrode with magnesium oxide. This is shown clearly at C. in Fig. 2. This is an added

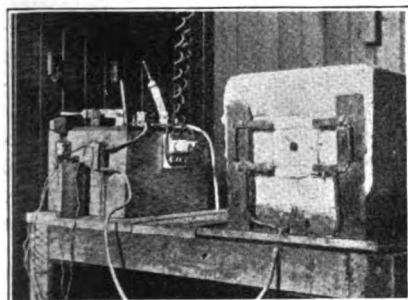

FIG. 11.—COMPLETE INSTALLATION—TRANSFORMER AND FURNACE

protection to the electrode beside the hood.

We noticed that the front terminal plugs were deteriorating but only when the hood was left off the furnace for a considerable length of time. To obviate this difficulty we determined to reduce the heat in the plug by decreasing its resistance. The outer ends of the terminal plugs were, therefore, fitted into brass shells as shown in Fig. 2.

We noticed also that when 300 amperes were flowing through the furnace at the highest voltage, the primary current never exceeded 18 amperes. Two 20 amperes fuses were therefore placed on the transformer box between the 200-volt line and the primary winding.

In order to avoid the use of any instrument, we designed an overload alarm (see Figs. 8 and 12) and placed it in series with the secondary winding of the transformer.

The alarm device consists of a solenoid and laminated iron plunger. When the current reaches 100 amperes in the secondary, the plunger is drawn up into a solenoid completing the circuit between a dry cell battery and an electric bell on the same principle as the electric push button.

With these improvements we obtained a temperature of 2200°F. in 13¼ hours. The temperature rise of the transformer bath was 25°C. The standardization rules of the American Institute of Electrical Engineers require that the temperature rise of the transformer bath shall not exceed 50° Centigrade.

Time	Secondary amperes	Furnace Temp. °F	Transformer Temp. °C
9.25	50	0	22
9.45	70	1050	25
10.00	85	1150	28
10.15	100	1625	35
10.30	100	1850	39
10.45	100	1975	45
11.00	100	2100	47
11.10	100	2200	49

TABLE NO. 3  
Time required for starting  
General Conclusion

The tests of the furnace showed it to very satisfactory for the heat range desired. The temperature throughout the furnace was uniform and very steady. The furnace was actually used to harden 25 high speed steel tools. The prevention of the formation of the oxide on the surface of the tools, which was an object aimed at in the design of the furnace, was accomplished. The atmosphere in the furnace, if not natural, is slightly reducing.

Another advantageous feature is that the time required to bring up to heat a set of tools, which are replacing a set which have just been heated in the furnace, is very short.

We believe that we have obviated the deterioration of the carbon to a great extent, and that the furnace will last a great while without the necessity of any repairs.

In the design of the furnace we have not considered the factors of abuse that would be met in commercial practice. The furnace as it now stands is only a laboratory furnace and must be handled carefully.

In looking back over the work, we see opportunities for improvement in the design. Whereas a contrivance may be designed to reduce repairs to a minimum, nevertheless, these will eventually be necessary, and the design should make possible quick and easy repairs. The suggestions for improvements that we would make would be almost entirely along this line. As the furnace now stands, in order to replace

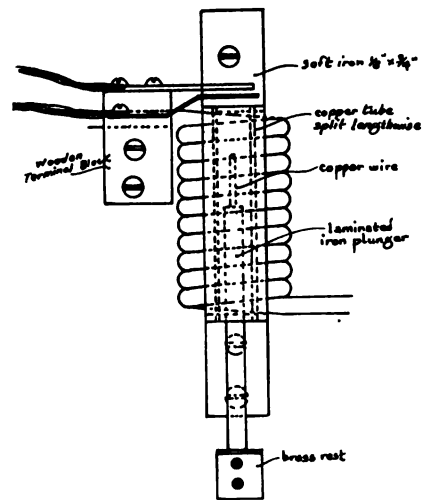

FIG. 12.—THE OVERLOAD ALARM AND HOW IT WAS MADE

the granulated carbon or the electrodes, the two front wooden uprights must be unscrewed at the base and swung back. The front slab of insulating material must then be removed, before access is obtained to the front electrode and the granulated carbon. The worst repair would be a repair of the rear electrode which would require the removal of the front electrode, the granulated carbon and the inside muffle. Attention to these considerations in the design of another furnace would reduce the time required for repairs considerably. Outside of the question of repairs, our next suggestion would be the replacing of all woodwork by metal, due care being taken to have all electrical connections well insulated. Besides giving longer life to the furnace this would prevent fire dangers.

Under the maximum working conditions of 2200°F. the power consumption was 3 K. W. This makes the cost of running just about the same as the gas furnaces now in use at the Worcester Polytechnic Institute.

### Some Suggestions for Discontented Partners

ELTON J. BUCKLEY

The following, which comes to me from Chicago, has a familiar sound:

Mr. A, senior member of a firm, owns two-thirds of the business. Mr. B, junior member, owns one-third. Mr. B gets one-third of the profits and does most of the work. He has become dissatisfied and wishes to sell out. He has not sufficient money to buy Mr. A's interest, and Mr. A will not buy him out, for he needs him and his influence in the



business. Now, the question is, if Mr. B finds a buyer for his one-third interest, can Mr. A refuse to accept the buyer as a partner, thus compelling Mr. B to retain his interest in the business?

All over this broad land there are partnerships in precisely this situation. In fact, dissatisfaction between or among partners, over the feeling that one is doing more work than the other, or getting more money, is one of the chief drawbacks of partnership. My observation is that very rarely indeed do you find a combination of two partners—it is even rarer, I believe, with two partners than with more—which is so well matched that each member of it is satisfied with everything that the other does.

I have always advised men who came to me wanting to form a partnership, that this was the rock on which very many firms split, and that if such a situation arose, they would not find it as easy to get apart as it had been to get together.

I can answer this inquiry and discuss some generally interesting phases of partnership law at the same time.

This correspondent does not tell me what sort of a partnership agreement these people have. It may be merely a verbal understanding to yoke up together on certain terms, not for any particular period. Or it may be a formal written agreement, as it should be, for a definite period.

If it is an informal partnership not for any specific period, either partner can withdraw from it any time he likes, merely by giving notice to his fellow partner. Some States (Arkansas and Louisiana) require the withdrawal to be done in good faith, and will not permit it to be done at what is obviously so inconvenient a time as to intentionally embarrass the firm. But in most States it can be done on reasonable notice at any time.

Of course a partner who withdrew in this way could expect to sell his interest. He would usually offer it to his fellow partners first, and if they refused, then to some outsider. The law will permit him to sell his interest to an outsider without restriction—but it will not admit his buyer to a partnership in the firm without the remaining partners' consent. In other words, the law will not force a partner on anybody. It will not create a partnership without both partners' consent. So that in the above case A can refuse to

accept B's buyer as his partner, and this will usually block the sale, but not always. For the outsider who buys the outgoing partner's interest can always demand an accounting from the remaining partner, and this usually winds the firm up. If the remaining partner doesn't want it wound up, he will sometimes accept the new partner in order to avoid that.

All that a man gets who buys a partner's share in a business—if that share is one-half, say—is the right to one-half the firm's assets after all its obligations are paid. He doesn't get a share in a going business at all. The accounting which he can ask for is for the purpose of ascertaining the net assets and giving him his share.

Of course if the remaining partner accepts the buyer as his partner, there is no accounting, and the business goes on as before.

If the partnership agreement is formal and written, and is for one year, say, either partner must wait until the year is out before he can withdraw, unless he wants to incur a damage suit for breach of contract. In Pennsylvania, Utah, West Virginia, Connecticut, Iowa and New Jersey, the law will hardly permit a partner to withdraw until the year is out. In other States he can do it, subject to the risk of suit for damages. The partner, under such an agreement, can sell his interest, just as a partner can under the other kind of an agreement, subject to the same legal restrictions.

The way to get an accounting in such a case is to go into court, either in an equity proceeding or in a common law accounting proceeding, and set forth that the partnership having been dissolved by the sale of one partner's interest to a third party, which third party has been refused admission to the firm by the remaining partner, accounting is demanded by the buyer of the outgoing interest.

I think I neglected to say that the sale of one partner's interest to an outsider automatically dissolves the firm.

How could B have avoided this situation in the beginning? Of course he could have done it by having a written agreement with A, binding either party, if the other withdraw and sold his interest, to accept the latter's buyer as a substitute. Usually neither partner likes this in the agreement, as it is almost too much to expect. Or the agree-

ment could bind each of the partners to buy the other's interest in case of withdrawal. Outside of these or some modification of them, there is no way in which such a situation could be avoided. It is one of the risks of partnership.

(Copyright, by Elton J. Buckley.)



## The Horseshoer

### Shoeing the Ankle Hitter

E. W. P.

Ankle hitting is the commonest phase of interfering in front. It consists in the animal striking the inside of the fetlock, or ankle with the inside of the shoe or hoof of the opposite foot, resulting in more or less injury to the fetlock, according to the severity of the case. In some, the friction merely rubs off the hair, in others the blow struck is so severe as to cause considerable swelling and lameness and sometimes permanent injury to the joint. And it should be remembered that any enlargement of the joint increases the difficulty of the foot passing without striking the enlarged ankle.

There may be a combination of causes working together to produce

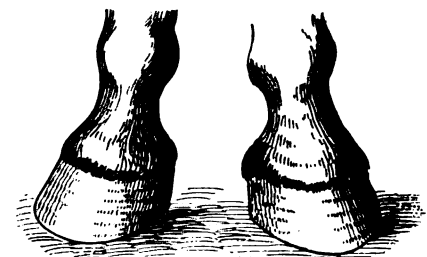

FIG. 1.—THE TOE-WIDE POSITION WHICH CAUSES THE HORSE TO HIT HIS ANKLES

interfering, but the predisposing cause is invariably defective conformation of the limbs. And as the toe-wide position shown in Fig. 1, is by far the commonest defect of the front legs, we will deal with that defect only in this article.



In the toe-wide horse the legs are not set square on the body; the whole limb may be twisted from the elbow down, or perhaps the cannon bone and pastern only are affected. Sometimes the leg only is toe-wide, while its fellow sets square on the body. Of course there are many other defects in the conformation of the fore legs which cause interfering, but we can only deal with one in a short article, so we will stick to the toe-wide position, of which Fig. 1 (being drawn from life) is an excellent example.

The knee of the horse is a true hinge joint; if the limbs are set on square to the body, the toe, when the knee is bent, will point to the hind leg on the same side, but if the fore legs are inclined outwards—

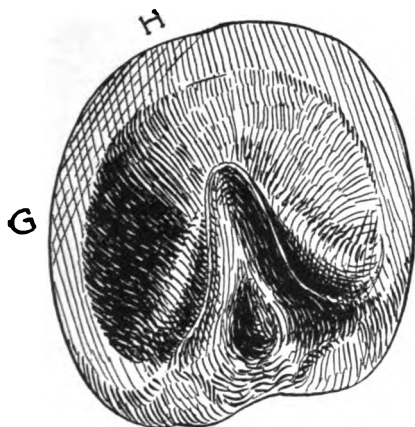

FIG. 2.—THE GROUND SURFACE OF THE FOOT

toe-wide—then the toe of the front foot, when the knee bends, points to the hind leg on the opposite side; in other words, the feet of the true conformation move over a straight line, while the toe-wide horse describes a semi-circle to the inside. If you wish to demonstrate the mechanism of this proposition, take two pieces of wood about 18 inches long by four inches wide; hinge them together with a common strap hinge; take this and stand in front of a horse; hold your pieces of wood in front of one front leg and square to the horse's chest; now bend the hinge to imitate the movement of the knee and the end of the piece of wood will point to the horse's leg; now place your pieces of wood at a slight angle to the horse's chest, so as to represent the toe-wide position, and you will see the end of your piece of wood pointing across the body, so when you realize that the toe-wide horse raises his foot under and across the body you will appreciate the mechanical impediment to

clear going. Have a toe-wide horse trotted towards you, and his characteristic action will surprise you. Moreover, when you observe how dangerously close they travel, even at their best, you will not be surprised that they interfere.

Horses of this conformation, in a natural state, wear the ground surface of their hoofs to a peculiar shape. If you observe them closely you will find the inside somewhat straight with a long inside toe, while the outside toe and quarter will be rolled at the "breaking-over part," Fig. 2. This, then, is the proper way to prepare the hoofs for this conformation. Use a shoe like Fig. 3, fit full at inside toe, but close at A, B,—the point of contact—and roll the shoe at the outside toe and quarter, C, D. Horses of this conformation, even when in good condition are likely to interfere; so that loss of condition, over-work, pain in the feet or legs from any cause will readily make such horses interfere. Therefore, we see that a careful study of each case is necessary, for you cannot cure, by shoeing, a horse that interferes as a result of leg weariness or pain in a foot from a corn, or the development of a splint, etc. If your toe-wide horse is in condition, and free from pain in feet and legs, and still interferes, you may look to the shoeing for the cause. The most important part of shoeing is the preparation of the hoofs. They must be pared to suit the conformation of the limb. Don't use more iron in the shoe than is necessary to a month's wear. Of course, other varieties of conformation will require various methods of treatment, but for the toe-wide horse, the application of these principles will prove effectual. Use a properly fitting boot to protect the part, until you are sure that your horse is going clear.

### British Shoeing Smiths and the War

*From a London Correspondent*

The art of horseshoeing in the United Kingdom might very well have fallen lower, with the advent of mechanical traction but for the influence of a modern survivor of one of the medieval city guilds, that of the Farriers, which may be congratulated on the good work done of recent years in recognising defects and providing or promoting instruction, and holding examinations by appointed experts. The

British county councils have appointed instructors, or "gone halves" in one if unable to afford one each, and there has been a general raising of the standard of shoeing smiths and their work. The number of apprentices had fallen off owing to the attractions offered by the higher wages paid to motor mechanics. Better pay, less dangerous and less laborious work, were to be had and the youth of the country could not be blamed for neglecting the shoeing forge for the motor works and the garage. Then came the war, and a sudden and unprecedented demand for shoeing smiths such as was never known before, despite motor traction and haulage by steam and other engines. Shoeing smiths who had been doing a "linger and

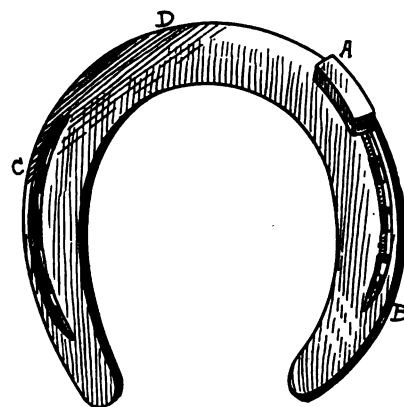

FIG. 3.—THE SHOE FOR THE ANKLE HITTER

die" business of their own were promptly put on at a fair wage, and instructors enrolled who could teach handy men to apply their knowledge of iron work to the subject of horse shoeing.

Classes were formed and pupils taught the structure of the foot, many hoofs and bones and fresh specimens being shown, and the parts described, with an avoidance of technical language, which might confuse. The men thus acquired a groundwork of anatomy of incalculable value and such as the average apprentice does not get, unless by his own zeal he has picked it up or had the opportunity of attending County Council classes. The urgency of the matter was such at the beginning of the war that all precedents were set aside, and the work of cold shoeing was given pre-eminence. Not from bar iron did they learn at first to "turn" a shoe, but received ready-made ones of various sizes and patterns, and proceeded at once to learn the art of putting them on. The term "cold" shoeing



is a little misleading, as the shoes are not put on cold, although such a thing is possible under war conditions. The selection of a shoe that will fit the foot, and not the cutting and rasping away of a foot to make it fit the shoe, is what is taught, and when selected the shoe is heated and fitted or pressed against the hoof in the usual way to show where it is in fair contact and where not, then the minimum amount of "knife" is necessary to "seat" the shoe. Particular attention is given to the clenching of the nails, which must be done in a serviceable manner, but not necessarily with the



THE SHOP DOORWAY REPRESENTS A HORSE SHOE

finish that is expected in the case of a gentleman's hunter in a fashionable country. The loss of a shoe in warfare is a very serious matter, as the old saw reminds us. Clenches which stick up may cause damage, and the happy medium is sought between these extremes.

Relays of "cold shoers" have been passed out from the various camps after a practical examination by a board of experts, while a higher class of farriers have been put to fair tests before giving them the more responsible positions.

After the war a large proportion of these men will have had good practice in horse-shoeing, and make most valuable colonists and settlers, and a residum will go back to the towns and villages with a more intelligent interest in their work, and capable of engaging in other kinds of construction where smithing is needed. These men will have had the advantage of association with others more advanced, and been inspired with ambition to succeed in their craft. This must be all to the

good. Many have had opportunities of attending a course of instruction which has embraced the management of diseased or abnormal feet, and having been taught the rough outlines of anatomy and seen sidebones and ringbones boiled out as well as actually shoeing the subjects of such defects, will bring to bear an amount of intelligence and interest as will greatly benefit the farmers and other horsekeepers who employ them. Many village minds will have been enlarged and the men will take wider views of life and work and be better citizens as well as better craftsmen. The farrier's skill has not yet met with its due reward, either in pay or appreciation hitherto save by the few horse owners who know the practical difficulties and are willing to pay for more frequent shoeing and for special attention to feet diseased and abnormal. Take the matter of corns, for instance! The uninstructed owner takes for granted that their presence is the fault of the shoeing smith, while it is usually his own, for attempting false economy in making shoes last too long. The reduction in the number of carriage horses and hacks, whereby the farrier earned much of his income, must be expected, but the British farmer will need the smith as much as ever, and it is "up to him" to try to make it worth while for the village blacksmith to stay in the village, and not take his skill to other branches of iron work, or to new countries where he may hope to get full value for his services.

## Thoughts on Timely Topics

Caustic Censure and Cheery Comment

BY THOENTON

TALKING ABOUT THE HORRORS OF WAR makes a person realize that it is purty serious business. But I'm wondering right now if the folks that usually exclaim and wonder over the casualties in the trenches on the battlefields and behind the guns, ever give a thought to the dangers of life behind the anvil. You can talk about "Big Lizzies" and "Jack Johnsons," as some of the big guns over across the pond are called and about the damage they inflict, but let me tell you right now that the bombardment in a smith shop where they occasionally lose sight of the Safety First idea has the little battlefield engagement lashed to post. Take that case of Bill Hawkins for example. Bill was

working at his anvil contented as you please, fitting up a set of shoes for Rol. Johnson's mare. His man, Wilson, and his helper were cutting rivets on a tank which Abner Bruno wanted fixed. Well Bill told his boys that Ab. was wanting that tank by afternoon and he told 'em to hustle, and hustle they did. They were in such a hurry that they didn't take time to put up the rivet shield and when they carried Bill home the Doc. found him wounded in the calf, thigh, the upper arm and two gashes on his head.

Then take that accident over to



L. M. MESSERSMITH IN THE DOORWAY OF HIS IDAHO SHOP

the M. B. X. and Y. shops at Railroadtown. The men had that great big hammer going—they call it "Big Bill"—and were knocking out some big pieces for some of those new triple-X engine frames. There were about two hundred men working in the shops and had been for some weeks. Well, young Doty Brasher had the levers of the hammer. Back of him, about four or five feet, they put in a new fire where Arch Mills and his helper were at work. Well, Arch had just taken a big gob of bristling, white stock out of his forge when the crane handlers serving the big hammer placed a newly heated billet under the drop. Arch and his man fell to work on their piece just as young Brasher was about to bring his drop down to locate the work when a big spark from Arch's piece hit Brasher back of the ear. Brasher was so overcome by the pain that he fell against his levers and the drop came down on that piece of sizzling white hot metal and scattered destruction to



practically every corner of the shop. I'll tell you, cold steel isn't in it with the close range shooting of white hot metal.

Then there's Tim O'Connell over Middlebrook way, I understand he's hobbling around with a crutch and cane because that big gray of Joe Larnier's stepped on his foot. And Will Foster, of the International, tells me that a number of the boys on his route are laid up too. There's Royal Eggleston over at Mill's shop—he was walking past the saw bench with a keg of shoes from the stock room when he slipped on the smooth floor. When they picked up what was left of him they found several fingers missing, his right ear partly chewed off and a face that may possibly return to some recognizable shape with age. And there's Luke Humphrey—of course he didn't have no reason for puttering around in Hob. Ransom's shop. He had his horses in for a set all around. And while waiting, he got fussing around in the back end of the shop. Well, Lew. Norman, one of Hob's. men, was grinding a plowshare and was hustling to get through when the emery wheel let go. Of course, Luke happened to be right in line of one of the pieces. When the doctor examined him, the Doc. said that if Luke hadn't been a six-footer they'd had to call the undertaker instead of a doctor. As it was Luke was laid up for about three weeks with a gashed shoulder and chest.

I tell you, you can't be too careful these days. Shields and protectors more than pay for themselves in arms, eyes and limbs saved. It is far, far better to install emery wheel shields and other safety-first devices than to be continually jumping toward the phone to ask the doctor to sort out the anatomy of some poor soul who has been caught in the web of a smith shop accident.

**HORSESHOE PITCHING**, I notice by the papers, is getting pretty popular. Cities and towns all over the country are taking it up and the outlook points to a popularity for the good, old, back-lot, sport second only to baseball. And who knows but what the pitching of the metal crescents may not develop a Ty Cobb or a Walter Johnson just as the pitching of the sphere has. And it is not difficult to expand the imagination to the point of the horse footwear game taking on national proportions, with city, state, inter-state, national and international leagues,—with grandstands, fields, pennants

and baseball—I mean horseshoe extras. And the yells of "glass arm" "bone head," "ivory dome" and "take-him-out" will be replaced by "iron bean," "steel wing," brass top" and "rap him on the anvil."

And may not this bring the forger of horseshoes again back to his own? Surely, an increased call for the crescent-shaped metals will be felt and who other than the professional practical horseshoer can supply the properly shaped and properly weighed equipment? If there isn't a horseshoe pitching club in your town, why not start one? A horseshoer for president would be a reasonable requirement in the constitution and by-laws.

## The Smith in The Daily News

Odd Mention of Anvil Ringers and Knights  
of the Forge in the News of the Day.

### Child Killed by Smith's Tongs

A remarkable accident occurred in Dennis Street, Waverley, N. S. W., as a result of which a six-months-old infant was killed. The mother of the child was walking along Dennis Street with the child in her arms. When opposite a blacksmith's shop a pair of tongs shot over the fence and struck the baby on the head. A man had thrown the tongs in the direction of a horse in the smithy. They hit the horse, but rebounded and flew over the fence to the footpath, striking the child. The little one was removed to a hospital and died the same night.

An outcome of the accident was the arrest of Michael Trevor, a blacksmith. At an inquest held on July 12th evidence was given to the effect that Trevor threw the tongs at a restless horse. A verdict of accidental death was returned.

### Smith Hurls Barrel Through Window

A Bridgeport (Conn.) blacksmith, feeling somewhat peeved after a fight in a wet goods emporium, picked up a beer keg and hurled it through the window. As he agreed to pay for the window he was not arrested.

### Wants Anvil as Monument

An Alton blacksmith recently died and requested that his anvil be used as a monument to mark his last resting place.

### Strong Smith Helps Lazy Man

Hugo Sellger, a blacksmith and wheelwright, picked up a medium-sized man and tossed him over a front yard fence. Mr. Sellger is noted for his large arms and powerful chest.

The young man who went through the unusual experience of being tossed over a fence, was first seated at the curb.

"Why don't you keep out of the sun

and get a seat in a shady place?" suggested Mr. Sellger to the man at the curb.

"Too much trouble," replied the one "Well, then here's a lift," remarked Mr. seated.

Sellger as he proceeded to pick up the person bodily, one arm under the knees and the other around the back and shoulders.

"Now, over the fence we go," said Mr. Sellger as he gave the man he was carrying a toss up in the air.

The man cleared the fence easily and landed on the lawn. He was too surprised to argue.

### Aurora Shoers Raise Prices

Aurora (Ill.) horseshoers have issued the following list of prices:

For common shoes, 4 new shoes, \$2.50 and up; 4 new shoes, size No. 7, long heel, and No. 8, \$3; 4 shoes reset, \$1.50 and up; 4 new steel plugs, \$3; bar shoes up to No. 6, each \$1; bar shoes No. 6, up, each \$1.25; bar shoes reset, each 50 cents; No. 0 to No. 6, per pair, \$2.50; No. 6 and up, per pair, \$3; Never-slip shoes, No. 0 to No. 6, per set, \$3; No. 6 and up, \$3.50; never-slip shoes reset, \$1.50 and 5 cents each for calks; never-slip calks put in on foot, 10 cents each; drive calk shoes, No. 0 to No. 7, per set, \$3; No. 7 and No. 8 each \$1; drive calk shoes recalked, per set, \$1.25 or 8 cents each per calk; leather packs, 25 cents each.

### Original Remington Anvil

The original anvil used by Remington in making his first gun was exhibited in Ilion, N. Y., during the centennial. The anvil is the property of Supervisor William Bliss of the town of Columbia. The anvil was purchased by his grandfather, Joseph Bliss, at the time Remington moved from the old forge to Ilion in 1828, and has been in the Bliss family ever since. It was owned by Jabez Bliss, father of Supervisor Bliss, for many years. The anvil, which is very much like the present day model, is well preserved and is a valuable relic.

### Wagon Gone—Blacksmith Sued

Because the wagon that he sent to a Rochester blacksmith disappeared from the blacksmith's premises, the owner of the wagon started an action to recover \$100—the value of the vehicle.

The owner says that he sent his wagon to the blacksmith shop for repairs. A week later he asked the smith for the wagon and the blacksmith replied the vehicle had been stolen. Thereupon the owner sought to have the smith pay for the wagon, because the blacksmith is alleged not to have exercised proper care in watching the plaintiff's property. The smith says he is not responsible for the wagon. He says he exercised as much caution in watching the vehicle as is customary in the trade.

### Hot Metal Causes Blood Poisoning

P. W. Lattrell is the victim of an unusually quick attack of blood poisoning. Tuesday morning while welding, a splinter of red hot metal struck him in the hand, sinking quite deeply into the flesh. Wednesday morning his hand was swollen and it was declared to be blood poisoning. The hand was found to be badly infected and Mr. Lattrell is said to be in danger of losing his hand.



## Fall—The Blacksmith's Season

W. O. B.

There's a lot of satisfaction  
For the blacksmith in the fall;  
When the nights begin to lengthen  
And he heeds the fireside's call.  
When the fields are brown and yellow  
And the crops are rolling in,  
Then the farmer's purse and barn loft  
Fatten out where they were thin.

When the winding road thro' township  
Over hill and dale and glade,  
Is wind swept, drear and cheerless;  
And with swirling leaves o'erlaid,  
When the wind of fall is whistling  
'Round the smithy day and night,  
Then the farmer's purse is fatter  
And he'll give the smith his mite.

Storms will follow fall aplenty,  
There'll be snow and ice galore;  
And the cold will find the marrow  
Of the smith through crack and door.  
He will shiver as with palsy,  
And he'll beat his arms about;  
But—the farmer's got real money,  
So the smith will smile and shout.

Yes, the blacksmith loves the fall time,—  
Though the days do shorten so,  
And the fields are thin and barren  
Where the crops of commerce grow.  
Yet he loves this time and season  
As he loves his anvil's din,  
For it's then he counts real money  
As the farmer's coin rolls in.



## Heats, Sparks, Welds

Lean collections will never make the purse fat.

Let us know what you think of this, the first number of Volume Sixteen.

It is not a good plan to suppose that overhead is something to be overlooked.

Tighten up on losses and expenses, and thus fatten profits without padding selling cost.

Quality is the best partner that price can have, and the two make a pair that cannot be beaten as business builders.

The Pink Buffalo Stamps are still working. If your supply is low, ask for a herd of Buffaloes. Now! Don't fail to use them freely.

Try it and see how much brighter and more cheerful the shop can be made. White-washed walls will lighten labors during

the closed door season.

The less work, the greater the proportion of overhead each job must carry. Remember this when you are tempted to take a job at a cut price "just to keep busy."

Apply the same reasoning to business and then work accordingly. It is easier to keep a horse in good condition than to build him up after he has lost his strength.

Did you ever look upon your scrap pile as an indicator? It is just as much an indicator on the smith shop as the steam-gauge on a boiler. What does your smith shop indicator say?

The days of ice and snow will soon be here. None too early right now to prepare for them. Tools in readiness, winter calks and shoes in stock, and sleigh goods handy for emergency. Are you ready?

Binders are ready for the fifteenth volume. They hold your copies neatly, cleanly and compactly. Better get in touch with our Subscriber's Service Department, and ask them about these binders.

When you cultivate the acquaintance of the man who cultivates the soil, you certainly expect to do some harvesting when he does his harvesting. A little bill harvesting is in order right at this time.

Peter Yukobrink, blacksmith by trade, is being sought for by his sister. Anyone knowing his whereabouts will confer a great favor by writing his sister, Mary Yukobink Earnest, Morris, N. Y.

British soldiers are said to receive about seven and a half million letters and seven hundred thousand parcels every week at the front while they write some five million letters to the "folks at home."

"Never too early to mend" is better than the old time worn "Never too late"—which seems to be Tom Tardy's guiding slogan. It appears to be the fertilizer which keeps holes in his shop roof growing larger and larger.

An advertisement to an advertisement must say something that means something. It must tell the reader something that will mean something to him. There's a difference in saying something in an advertising way and just simply talking.

Are you profiting on the prices you charge for your work in these days of advancing costs? When costs begin to fatten pad your selling prices in proportion. Don't attempt to absorb the extra cost in your all ready too clean profits. Are you figuring on a working profit?

Get the reward offered for new subscribers. Tell your neighbor smiths what THE AMERICAN BLACKSMITH is doing for you, and get them to join our big circle of satisfied subscribers. We will make it well worth your while. You know "Our Journal" and what it will do for the practical blacksmith.

Why are your customers your customers?—why do your non-customers trade at your competitors? Can you answer these questions? Why not find out the why of your business if you don't already know? You can hardly imagine the limits to which this information can be used, and how it may improve and increase your business.

Were you one of the hundreds of contributors to our columns during the past year? If not, now is a good time to make up for lost time. Every reader of "Our Journal" is expected to send in something for publication at least once each year. If you did not contribute to the volume

just closed, send in something for publication right now. Don't keep us waiting; we want something from you.

During the last year blacksmith materials have increased in cost from 35 per cent. to 40 per cent. and labor has increased accordingly. The hours of labor have been shortened so that now employes get more for an eight-hour day than they did for a ten-hour day. Yet some smiths still stick to the same old prices of five years ago and wonder why they aren't making money.

Unless your books are accurate barometers of your business you might better save the time you are wasting on them. Figures in books won't keep a business out of bankruptcy court. The real reason for keeping book records of a business is to show you just exactly where the business stands in a business way. Don't try to jolly yourself into thinking that you are doing a profitable business by juggling the figures in your business books.

Now! Today is the time to get after the toiling son of the soil and get him to settle. Don't let the money he owes you go into any more automobile equipment without a protest. Get busy and collect. The way to make collections good is to make them good, and right now is the best time to make them good. You can't do it by sitting in the shop and thinking about it. Your farmer customers have got the money now or should have it. You cannot get what belongs to you unless you go after it.

The faker is still abroad in the land. Let not your vigilance relax. The get-rich-quick expert who is out for your coin and for his profits—the fake subscription solicitor—the smooth-tongued stranger with the marvelous (?) welding or tempering compound and the faker with the magic plating solution are all birds of the same feather. We hope that none of "Our Folks" will help these chaps in their search for an easy living. When one of these fellows comes into the shop, lock the safe and whistle for the dog.

Molasses as fuel for industrial purposes is being produced in Hawaii and is to be shipped to the Pacific Coast to compete with California fuel oil. Until recently 70 per cent. to 80 per cent. of the exhausted molasses from the Hawaiian factories was thrown away as useless. Furnaces are now being installed which burn this molasses, the heat going to furnish steam for the factory, and the ash from the molasses, which contains 33.32 per cent. potash and 4.60 per cent. phosphoric acid, is used as fertilizer.

A swarm of bees kept in a city office is described in an exchange. For more than a year a bee fancier has kept a hive in his third-story office close by a window and a radiator. The latter has kept the bees warm in winter. In the side of the window frame a slot has been cut, and as soon as the weather permits, the bees can be seen starting on their search for honey. As an incentive to begin their hunt their owner placed a row of chocolate creams on the outside window sill. These were soon discovered and set the bees to humming; a little later they began their flights up and down the business streets and to regions far beyond. The bees visit the flowers which decorate the office windows and flower shops, and even discarded candy does not escape them. Last year the honey yield was about 50 pounds. This year the owner hopes for 75 or 100 pounds.

Our Honor Roll

AND STILL THEY COME

More and more readers are taking advantage of "Our Honor Roll" every month and it is becoming more difficult each month to find a place on the list of Honor Subscribers.

Table with 4 columns: U. S. and Mexico, Canada, Other Countries. Lists subscription rates for 2, 3, 4, 5, and 10 years.

Send your order and remittance now—today. Don't wait until you forget all about it. You'll never regret it.

Main subscription list table with columns: NAME, Subscription Paid to, NAME, Subscription Paid to. Lists names and locations of subscribers.

Continuation of the subscription list table from the previous block, listing names and subscription dates.





## Fundamentals of Lathe Practice

JAMES STEELMAN

In order to understand even the simpler engine lathes, it is necessary to know something of gears. Thus, if the lathe is back geared, we need to know how the gears on the cone pulley and on the back shaft cooperate to produce various speeds of the spindle. More important though for the practical working of a lathe is a knowledge of the gearing which controls the lead screw. Some men run a lathe without knowing much about speeds, but it is not the best way. If we have *screw threads* to cut, it is well to know just how the lead screw must be controlled by certain gears in order to get the right movement of the carriage carrying the tool. If we want to use tools to advantage on the lathe, we need to know something about the speed of the work. A good carbon steel tool permits us to cut ordinary work at 30 or 40 feet per minute. High speed steel permits us to double the speed. If we are going to use a lathe intelligently, we need to know something as to how fast we are taking the chip off the work.

An ordinary gear is a *spur gear*—that is, it is a wheel with teeth arranged on its edge. One gear is nothing by itself—there must be a companion gear, the teeth of the two interlocking as they turn. When the teeth properly interlock, the gears are said to be *in mesh*. Gears that are in mesh are on different

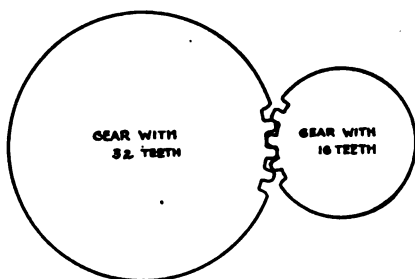

FIG. 1.—SUPPOSE ONE GEAR HAS 16 TEETH AND THE OTHER 32

shafts. With spur gears the shafts must be parallel.

There are two kinds of speed spoken of in connection with rotating gears. The *rotational speed* is the rate at which complete turns are made. Thus the rotational speed of a certain gear may be 300 revolutions per minute (300 r.p.m.). We do not care how slow or how fast the teeth are moving through the air: in connection with rotational speed, we think of *turns* be-

ing made. Rotational speed is often spoken of as *angular speed*. However for some purposes we may want to speak of the rate at which the teeth of a gear travel in their circular path. Thus, a tooth—or rather the center of a tooth—may be moving at the rate of 100 feet per minute. This kind of speed is called *peripheral speed*. We may, in the case of gears, speak of this kind of speed another way. Thus, we may say that the teeth of a certain gear are passing a certain fixed point at the rate of 1000 teeth per minute.

We come now to some important matters. When two gears are rotating in mesh, the one gear driving the other, the peripheral speed of the one gear is the same as the peripheral speed of the other. In other words the teeth of the one gear are passing a given fixed point at the same rate as the teeth of the other. One gear may be very big and the other very small: it makes no difference. If the teeth of the big gear are moving along at such a rate that 20 pass a given fixed point in a second, then 20 teeth of the little gear will also be passing the point in a second. In fact, it is to secure the same peripheral speeds that gear teeth exist and interlock. One gear *forces* the other to precisely its own peripheral speed. It is entirely different, however, with the rotational speed. If one gear is larger than the other—and this is usually the case—then the rotational speed of the big gear will be less than the rotational speed of the small one. We can in fact find out how much faster one rotational speed is than another, if only we know the number of teeth in both wheels. Suppose, for example, that one gear has 16 teeth and the other 32. (See Fig. 1.) When the big gear has turned around once, 32 teeth have passed a fixed point. Since the peripheral speeds are the same, we have at once that 32 teeth of the smaller gear have also passed the same point in the same time. But the little gear hasn't 32 teeth; it has only half that many. Consequently, it has to turn around twice. In other words, the rotational speed of the little gear is twice the rotational speed of the big one. If the little gear has 8 teeth, its rotational speed would be 4 times as great as that of the other gear. Suppose the little gear had 24 teeth. One turn of the big gear would mean 1 and 1/3 turns of the little gear. Going around once, the little gear would only bring up 24 teeth;

but by going around one-third of a turn further, it would have brought up exactly enough to equal one turn of the big one.

If we divide the number of teeth on one gear by the number of teeth of its companion, we shall have the number of times the second gear turns when the first turns once.

If this rule is thoroughly understood, there should be but little

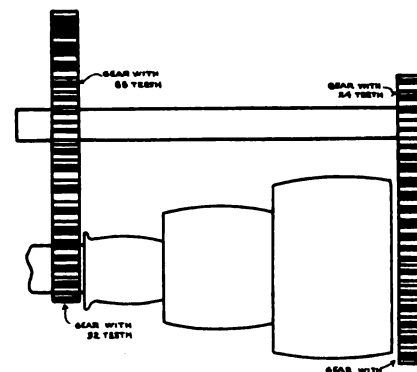

FIG. 2.—AN EXAMPLE IN CONNECTION WITH BACK GEARING

difficulty in understanding the gears connecting the lead screw and the spindle, and also the gears of the back bearing.

Consider an example in connection with back gearing. See Fig. 2. How many times as fast as the rotational speed of the cone pulley will the rotational speed of the spindle be, if the bearing is arranged as follows? The pulley gear (gear driven by pulley) with 32 teeth meshes with a back shaft gear with 88 teeth; the little gear on the back shaft has 24 teeth and meshes with a spindle gear with 96 teeth. We divide 32 by 88 and get 4/11. This is the number of times the back shaft turns with one turn of the pulley. That is when the pulley goes round once, the back shaft will rotate 4/11 of a turn. Also we divide 24 by 96 and get 1/4. This is the number of turns made by the spindle to one turn of the back shaft. That is, one turn of the back shaft will rotate the spindle 1/4 turn.

The way the matter now stands is this. When the pulley goes round once, the back shaft goes round 4/11 of one time; and when the back shaft goes round 4/11 times, the spindle goes round 4/11 x 1/4 time. We thus get 1/11. The final answer is that the rotational speed of the spindle is 1/11 as fast as the rotational speed of the cone pulley.

Take a case now with the lead screw. See Fig. 3. We will suppose that we have on the end of the

spindle a gear with 24 teeth and that it meshes with a gear of 32 teeth on the lead screw. How many times as fast as the rotational speed of the screw will the rotational speed of the spindle be? We divide 32 by 24 and get 1-1/3. This means that the spindle goes around 1 1-3 times as often as the lead screw. This is a very practical example. As the lead screw turns it carries the carriage. If the lead screw has a pitch of 1-6-inch, then 6 turns will move the carriage 1 inch. If the spindle turns 1 1-3 times as fast, then these 6 turns of the screw will correspond with the spindle turning 8 times ( $6 \times 1 \frac{1}{3}$ ). This means that the carriage will move at such a rate that while it is going 1 inch to right or left, the spindle will turn around

screw and changes on the spindle. The object in view in making various combinations is to make it possible to cut screw threads of various leads. The lead of the lead screw is always the same. A certain number of turns will move the carriage one inch. The gears can't affect this. The operator of the lathe should find out the lead of the lead screw and bear it in mind. Suppose it is 1-6 inch. Then 6 turns will move the carriage 1 inch. If a screw thread of 1/8-inch pitch is wanted, then during the 6 turns of the lead screw the spindle must turn 8 times. If the screw thread wanted has 1-11 of an inch for its pitch—that is, 11 threads to the inch—then the spindle must rotate 11 times during the six turns of the lead screw. And so on. What we have to do is to find two gears—one for the spindle and one for the lead screw—such that, *when you divide the number of teeth of the spindle gear and then multiply the result by the number of threads per inch of the lead screw, you will get the number of threads per inch that will be cut on the work.* Thus, suppose the lead screw has a lead of 1/5 inch—that is, suppose there are 5 threads to the inch. Then suppose that the lead screw gear has 48 teeth and the spindle gear 40 teeth. Using our rule, we divide 48 by 40 and get 6/5. We then multiply this by 5 and get finally 6. This is the number of threads per inch that will be cut, using the 48 and 40-tooth gears. If we use the 56-tooth gear in the lead screw and a 20-gear in the spindle, we shall get, upon dividing 56 by 20, the number 14/5. Multiplying by 5, the number of threads per inch in the lead screw, we get 14 as the number of threads per inch on the work. The rule is not difficult if one understands common fractions.

**The Drive of the Lathe**  
Lathes are usually driven by a belt or else by a motor. In the former case the cone pulley is a very suitable appliance. On a shaft overhead will properly be arranged a countershaft and on it a similar cone pulley, only it will be reversed. See Fig. 5. A principal object of the

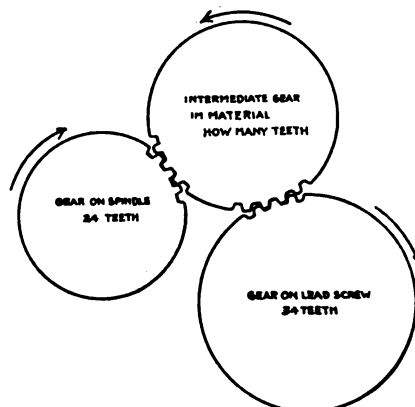

FIG. 4.—THE INTERMEDIATE GEAR MAKES NO DIFFERENCE IN CALCULATING

reversed pulley is to make it possible to shift the belt to various steps on the lathe pulley. The belt is at the same time shifted overhead. The sizes of the two steps in use at any one time being always such as to keep the belt at about the right tension.

Now, the countershaft will itself be driven probably by a short belt connected to the main line shaft. There is some importance in being able to determine speeds of the various shafts and pulleys in order to find out how fast the lathe spindle is operating. The whole matter is very similar to that of the spur gears. A belt will slip some, but for our purposes we will assume that there is no slip. The function of the belt is to transmit from one pulley to another the same *peripheral speed*. This is exactly what cogs in mesh do. However, in making calculations, we do not count the cogs because there are none. It is the

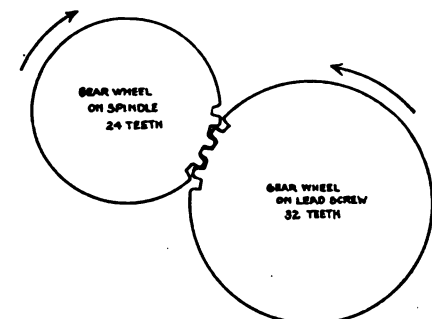

FIG. 3.—TAKE THE CASE OF THE LEAD SCREW

8 times. Consequently, we have proper arrangements for cutting a thread having 8 turns to the inch.

Now it may very well be that the gear on the spindle does not mesh with the gear on the screw; but that a third gear has to be made to mesh with both before the rotating spindle will cause the screw to turn and the carriage to move. See Fig. 4. This intermediate gear makes no difference in the calculations. *We pay absolutely no attention to the number of teeth it has on it.* The case is precisely the same as if the spindle gear meshed with the screw gear with the intermediate gear non-existent.

[The peripheral speeds of the spindle gear and of the intermediate gear are the same; the peripheral speeds of the intermediate gear and of the screw gear are the same; consequently, the peripheral speeds of the spindle gear and of the screw gear are the same. This is no more nor no less than what we have when these two gears are in mesh. So, in calculating, we may disregard the intermediate gear entirely.]

Lathes are furnished generally with an assortment of gears for the spindle and screw, so that varieties of combinations may be made. That is, we may make changes on the

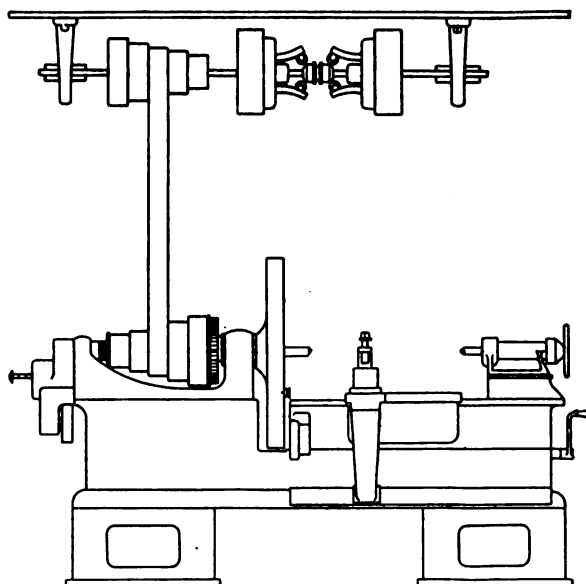

FIG. 5.—ON AN OVERHEAD SHAFT IS THE POWER CONE PULLEY



same, though, if we take the *circumference* of one pulley and the *circumference* of the companion pulley. Thus, suppose one pulley is 6 feet in circumference and its companion 3 feet in circumference, we are able to say at once that when the 6-foot pulley goes round once, the 3-foot pulley will go round twice. It is precisely the same as with companion gear wheels—if one has double the number of teeth of its companion, the latter will rotate twice as often.

It is easier generally to compare the *diameters* of pulleys, and thus avoid measuring or calculating the

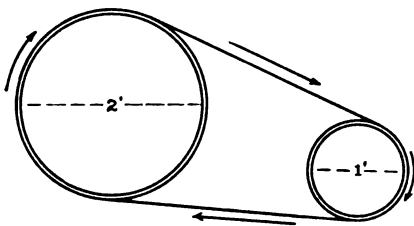

FIG. 6.—CALCULATING PULLEY SPEEDS IS SIMILAR TO GEAR CALCULATIONS

circumferences. See Fig. 6. It is just the same. If the diameter of one pulley is double the diameter of its companion, then the rotational speed of the latter will be twice that of the former. There is nothing really difficult. We are ready now for a practical example.

If the main shaft is running at about 150 r. p. m., how fast is the counter shaft running, if the main shaft pulley is 30 inches in diameter and the companion pulley on the countershaft is 20 inches in diameter? We divide 30 by 20 and get  $3/2$ . This means that the countershaft is rotating  $3/2$  turns while the main shaft is rotating 1 turn. Consequently, while the main shaft is making 150 turns, the countershaft will be making 225 ( $3/2 \times 150$ ).

If the countershaft is running at 222 r. p. m., what is the speed of the lathe cone pulley, if the driving belt is on a step, 14 inches in diameter on the countershaft cone pulley and on a step, 9 inches in diameter on the lathe cone pulley? We divide 14 by 9 and get  $14/9$ . This means that while the countershaft makes a single turn, the lathe pulley makes  $14/9$  turns. Consequently, in one minute, while the countershaft makes 225 turns, the lathe cone pulley will make 350, ( $225 \times 14/9$ ). The answer is 350 r. p. m.

What the lathe operator should do is to find out the rotational speed

of the cone pulley on the lathe corresponding to every step. If there is no back gearing, these speeds will probably be all the spindle speeds of the lathe. If there is back gearing, these speeds will be the spindle speeds when the back gearing is not in use and the cone pulley is locked to the spindle. *They should be set down for reference.* If the operator himself is unable to make the calculations, he may be able to get someone to use the foregoing rules and determine the speeds. If there is back gearing the spindle speeds obtained when this gearing is in use should also be calculated. In short, the operator should be in possession of the rotational speed of the spindle that corresponds to each and every way he may arrange the belt and the back gearing. He needs this information as a basis from which he may determine the actual speed at which the work is passing the cutting edge of the tool.

## Gas Engine Operation Made Simple—2.

The Purchase, Installation, Operation and Troubles of a Gas Engine.

J. L. HOBBS

### Cooling Systems

There are two general methods of cooling internal combustion engines, viz. the water cooled engines and the air cooled engines.

We will take up the air cooled engines first so as to get them out of the way and have more time and space to discuss the more universally used water cooled engines. There are two types of air cooled engines one that uses a fan of some description and the other which does not use a fan but depends upon the rapid heat carrying qualities of the metals used for this purpose to accomplish the desired end.

Engines which do not use a fan but depend on the metal to carry away the heat are not made in anything but small engines which are not required to give long hours of continued service. This method has almost passed out of use on account of the enormous cost of the heat carrying metals used.

The fan cooled engines may be divided into several different types in regard to the design of the engine. In some the fan is built into and a part of the fly wheel. In others the air is forced direct onto the cylinders by a fan which may be driven by shaft, chain, belt, gears or in fact any way that will drive it. The main

thing in an air cooled engine is the construction of the cylinders and the fan.

The cylinders of an air cooled engine which uses a fan for cooling generally have bands of the same metal of which the cylinder is made extending into the air around the cylinder so that the heat may pass out onto these rings and be taken from there by the fan.

The fan which is a part of the fly wheel, where it is properly constructed will of course give the best satisfaction, for the reason that when the fly wheel turns there is a circulation of air. Any positive drive is good, such as chain, gear, shaft, etc. and will cause no trouble while it is in working order, but all of these must be watched to see that they are not broken. For instance a shaft driven fan with a broken shaft would not do the engine very much good as far as cooling it goes.

Belt driven fans give the most trouble, as they always run, but frequently do not run as fast as they were designed to run, allowing the cylinder to overheat and to lose power. On the other hand the belt can be too tight and cause unnecessary wear upon the bearings. Be sure the rings on the outside of your cylinder are free from dirt and your fan is running up to its designed speed and you have a perfect air cooled engine. It is not the purpose of this article to say which is the best of the air cooled or water cooled types of engines, but we will say that either

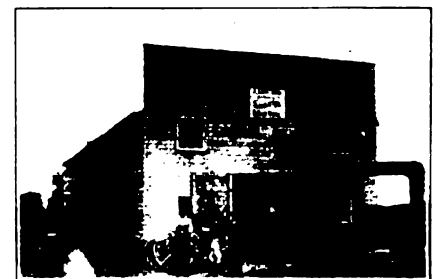

EXTERIOR OF THE SHOP OF S. SHORT AND SON

of these types when properly designed and kept in proper repair will do just what it was designed to do by the designer.

Water cooled engines will also include a class of engines which uses other liquids than water for cooling purposes, as the cooling system is the same for both or all of them. The most serious drawback to the water cooled system is the liability to freeze up in cold weather. Iron being a good conductor of heat, and



THE HOME FORCE BEHIND S. SHORT AND SON

the water in the cooling jacket being in thin layers the water is cooled very rapidly when the engine stops and in an incredibly short time will be frozen so that the cooling system will not work when it is again started. The most serious part of the freezing, however, is the liability of the water jacket around the cylinder being bursted by the cold. A great deal of attention should be given to the thorough draining of the water jacket and every other part of the cooling system in cold weather. You may think it will not be cool enough to freeze tonight, only to get up in the morning and find a frozen if not a bursted water jacket. An ounce of prevention is worth ten pounds of cure in the care of the water cooling system of a gas engine.

Water cooled engines may be of several different types as regards the kind of a pump or tank used. There are three general types of pumps used, the ordinary plunger, the rotary or centrifugal and the gear pump. There are two kinds of tanks used with cooling systems, one which has some sort of a radiator to aid in the cooling of the water, the other just a plain tank with openings in the top and bottom to allow a circulation of the water. All of these will be taken up and handled in their order and fully explained.

There is also a cooling system which does not require a pump for the proper circulation of the water. This system is called the Thermo-syphon system, named from the latin meaning of the two words. Thermo meaning heat and syphon to move or to flow. Thus we have a circulation which depends on the heat to move it. With this system any kind of a tank may be used, the necessary features to this system are the tank and the piping. The tank with a radiator or one without must be placed on a foundation with the bottom of the engine cylinder or a little lower. A pipe is run from near the bottom of the tank to

the bottom of the cylinder. Another pipe is run from the top of the cylinder to a point near the top of the tank. When the water becomes warmed from the explosions in the cylinder it begins to rise, and in doing so passes out through the pipe into the top of the tank. As this water passes out more cold water comes into the water jacket to take its place, which you will see causes a constant circulation of the water as long as the engine runs. This is a very reliable system, although it requires quite a quantity of water and is hard to handle in freezing weather.

The old plunger pump which requires a plunger and two valves is so well known and understood it is not necessary to take up time and space here to discuss it. The same piping works nicely with all the systems, with the exception that a little different piping is used where it is desired to use kerosene or some



THE SMITHING DEPARTMENT OF S. SHORT AND SON'S SHOP

of the less volatile oils as a fuel. This will come in in its proper place with oil burning engines.

The rotary or centrifugal pump is the one most commonly used in connection with cooling systems, as there are no valves to watch, and the drive is generally some positive type which causes no trouble. This pump consists of an outside shell, a shaft to which is attached a number of fan like blades to propel the water, a pulley or gear is on the end of the shaft to furnish the motive power. The water is allowed to enter near the center of the outer case of the pump. The rotation of the blades causes the water to go round the case, the centrifugal force causes it to want to leave the pump at the outer edge of the case. Means are provided for it to leave here as a pipe runs from this opening to the bottom of the cylinder. The other pipe is run from the bottom of the tank down to the center of the pump casing. It is necessary for the pump to be lower than the bottom of the

tank on account of keeping the pump case full of water for starting. After it has been started it will draw the water several feet.

In the gear pump the gears are made to pass through a small space at one side of the pump, and the space between the gears is filled with water. This is a slow method of pumping water, but is generally like some other slow things, very sure. These pumps are used with splendid results on engines which use the less volatile oils as a fuel and do not require an extensive circulation of water for cooling purposes.

For the use of less volatile oils as a fuel it is necessary to use a little different piping to secure the desired results. In burning gasoline the cylinder should be kept as near 180° of heat as possible as gasolene vapor works best at this temperature, but for burning kerosene or distillate a much hotter cylinder is necessary for the reason that these oils do not go into vapor rapidly below a temperature of about 325°. To produce this degree of heat it is necessary to shut off the circulation of the water and allow only water enough to enter the cylinder jacket to take the place of what escapes in the form of steam, either through the pipe which leads back to the tank or through the water needle valve into the cylinder. This is accomplished by placing a by-pass pipe from the pipe running to the cylinder to the pipe running from the top of the water jacket of the cylinder to the tank. You will readily see that the water being somewhat like electricity will take the shortest circuit and go back to the tank by the shorter route through the by-pass pipe. Enough water, however will go into the bottom of the water jacket to keep the space entirely filled with water and accomplish the purpose desired.

On account of the intense heat required to vaporize these less volatile oils there is a danger of the charges being ignited in the cylinder



S. SHORT AND SON OF MISSOURI ALSO DO WOOD WORKING



THE SMITH SHOP AND GARAGE OF G. F. WARDLE IS LOCATED IN A PROSPEROUS SECTION OF SOUTH DAKOTA

before the proper time, on account of the intense heat which remains in the piston head and cylinder walls after each explosion. To overcome this a spray of steam taken from the water jacket is turned into the mixture of fuel and air just as it leaves the carbureter or mixer and prevents this premature explosion. This is the obstacle which required so much time to overcome to make an oil burning engine a success, it is the same thing which stands in the way today to prevent automobiles using kerosene as a fuel. Carbureter manufacturers are racking their brain to find some way to prevent this preignition in the cylinders so they can use kerosene as a fuel. Some of these days this will be accomplished and then the high price of gasoline will be a thing of the past and forgotten.

An oil burning engine under a full load will use about as much water in the mixture that goes into the cylinder as it does fuel oil, but when running idle or until it gets hot the water in the mixture is not necessary and is a real detriment to the charge. Water should never be used with gasoline or natural gas as fuel. Only such a quantity as is necessary to prevent preignition should be used as more will do more harm than good. Pre-ignition or premature ignition can be detected in a cylinder by a kind of a metallic sound which sounds a good deal like hitting a piece of iron with a hammer. When this pre-ignition takes place open the water needle valve just a little at a time until it entirely disappears. It is well to shut off the water a little occasionally to see if you can prevent pre-ignition

with a little less water. A little variation in the mixture has a wonderful effect upon the power of the engine. After being around an engine a while you will learn to detect these little things by your ear. Everything about a gas engine produces a distinctive sound and when you learn to distinguish these sounds you have made a long stride towards success as a gas engine operator.

How to prevent the freezing of an engine without going to the trouble to drain everything every time it is stopped has been a problem upon which a good deal of time and thought has been spent. There are anti-freeze solutions which have been used with more or less success, but there are drawbacks to these solutions. All of them are hard on the metal of which the tanks are made and cause, sooner or later, either a leak in the tank or a stoppage of the circulation system, either of which is troublesome to

say the least. There are a lot of these solutions on the market and all of them have their good features and all of them their bad, but there is one thing mighty sure, and that is if you drain all the water out of your water jacket and tank and all the other parts of the cooling system, you will not have a freeze up and you will also be free from the troublesome features connected with the use of anti-freeze solutions.

When a water jacket freezes up and bursts it generally affects only the outside of the jacket, in which case it can be easily welded by the oxy-acetylene welding process, which can be done at almost any repair shop. When the crack extends into the inside of the cylinder it is almost a hopeless case, or at least very troublesome, nearly always requiring that the cylinder be rebored and a new set of rings fitted, which is about as expensive as a new cylinder. The new cylinder is much the best solution of the matter.

*(To be Continued)*

## Smith Work on a Whaling Ship

D. O. SHAW

The blacksmith on a whale ship is not over worked at his trade. In fact he has it so easy that for exercise, he is obliged to pull the midship oar in a boat when chasing whales. The writer will not soon forget his first attempt to forge a ring, when his forge started away from him as the ship rolled to leeward; nor the "two shillings and a bottle of gin" that the mate promised if their boat was the first to get fast to a whale. Our boat was the first to get a whale, but we are still waiting for the two shillings

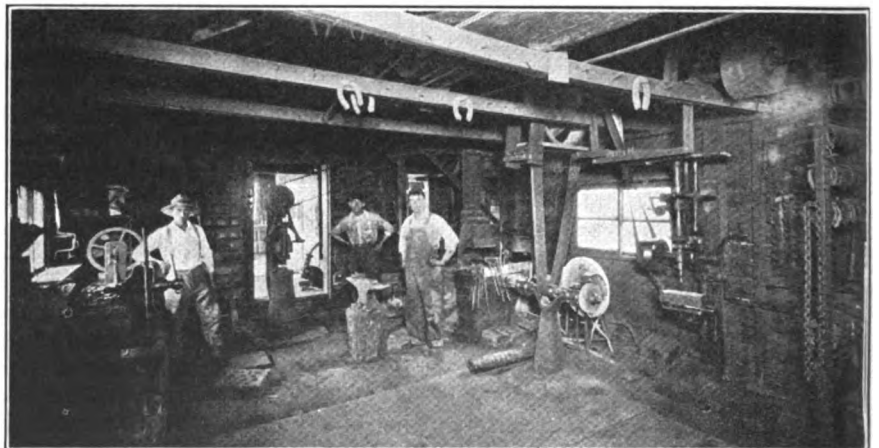

INTERIOR OF MR. GEO. F. WARDLE'S SOUTH DAKOTA SHOP WHERE AUTO REPAIRING AND GENERAL SMITHING IS DONE



and the gin which was promised us.

The method of going after whales in a steam-ship and shooting them with a cannon has not proved successful, and whalers have returned to the old way of catching these monsters of the deep. In the engraving are some of the tools used in this work. A harpoon at A is shown ready to be thrown. The shank is 3 1/2 ft. long and 1/2 in. in diameter. One end has a socket and in the other end is a slot to receive the spear. Just back of the spear rivet is a small hole for the stay pin. This pin is made of soft pine and is just strong enough to hold the spear in position in handling or being thrown. After the whale is struck and pressure is put on the line, the staypin breaks and the spear takes the position as at B. This harpoon can be thrown deeper and never pulls out as sometimes is the case of the old style harpoon shown at D.

You will notice in the engraving that the upper part of the spear is raised to cut ways for the heels. This harpoon was invented many years ago by a colored smith in New Bedford, Mass. I don't know what his circumstances were, but one thing is sure, he has given the world a harpoon that to my mind can not be beaten. I am not sure that the measurements I have given are exactly correct, but they are as near as I can remember. It has been sometime since I have handled these tools.

But suppose we join one of the boat crews as they leave the ship to go after one of the big monsters. We will then get some idea of the work and how much depends upon the good work of the blacksmith.

We have struck a whale, he has sounded and has come to the surface. We are pulling in 120 fathoms of line that he has run out of the boat. The next thing in order is to shoot him with the bomb lance G. The lance explodes inside the whale. The object of this is to weaken him so he will not be so dangerous to finish with the hand lance, shown at C. Some officers will not have one of these guns (see F) in the boat, for if you keep shooting bombs into him and do not hit a vital spot, the whale becomes fighting mad, and then if he does not stave your boat to get away, it will be because you have a well trained crew, and the officer does not lose his head. Another reason is that these bomb guns are about as dangerous at one end as at the other.

Once after getting fast to a whale, the captain took his gun to shoot, taking careful aim, he fired. The gun flew overboard and the captain fell backward knocked down the bow oarsman and then fell over the rail into the water. The boys caught him by the legs and with much difficulty, got him into the boat. The captain was not a profane man, but he did say "damn" after the excitement was over. Fortunately, he had made a good shot and the whale was easily finished with the hand lance.

We also have a long handle spade, E, on shore we would call it a chisel. After the whale is alongside the

too small to carry a donkey engine there is also the mincing knife and all clamps kept in shape by the whale ship smith.

### Illinois Blacksmiths Pull Unique Stunt

The outing of the blacksmiths of DeKalb, Illinois, and neighboring communities was one of the most unique, enjoyable and altogether profitable trips that members of the craft have ever taken.

The Knights of the Anvil not only had a most enjoyable outing trip but they met a lot of mighty fine

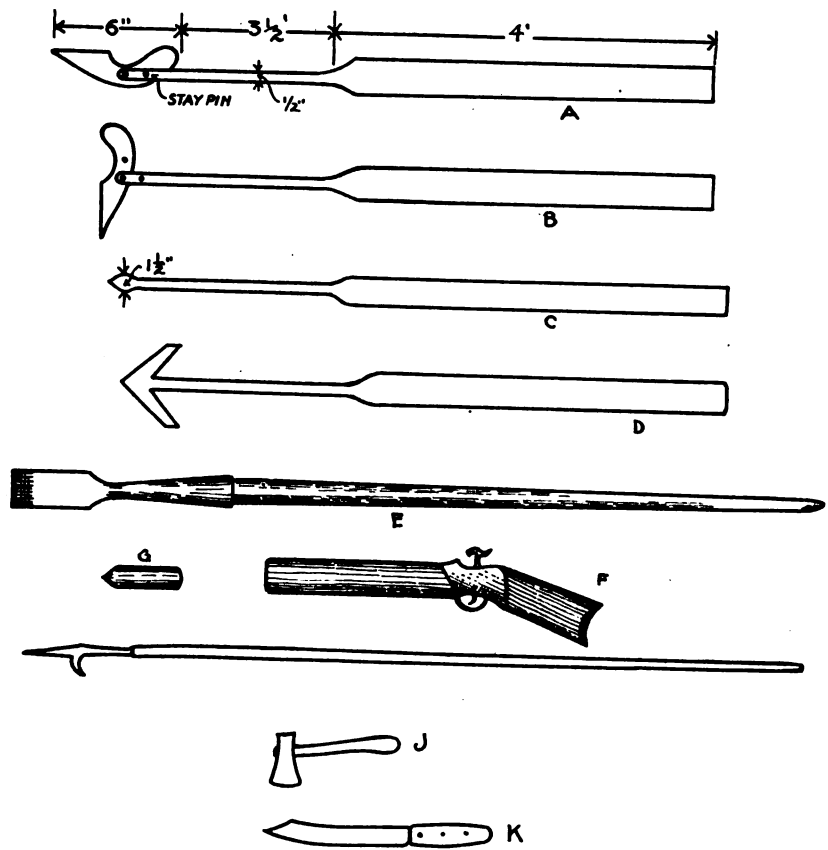

SOME OF THE TOOLS AND IMPLEMENTS MADE BY THE WHALING SHIP SMITH

ship a staging is swung out over the whale and the men stand upon this and with the spade cut out the blubber into strips as it is hoisted on board. The boat knife K, is sheathed near the bow to cut the line, if necessary. The boat hatchet J, is to hack the sharks when they get to rubbing up against the boat. The gaff H, is used for various purposes, sometimes in landing a porpoise, sometimes as a boat hook.

On the salt water, iron and steel take on rust quickly so these tools have to be polished often. There are other tools, such as blubber hooks, tongs, saws and cleavers. For ships

fellows among their craft in other towns, saw a lot of finely equipped shops and learned a lot that will be of use to them in their business as well as interesting a lot of good men in the association of smiths.

The trip was made by blacksmiths from DeKalb, Sycamore, Cortland, Virgil, Maple Park, Richardson and Kaneville. One load left Maple Park and went directly south to Big Rock where they visited the shop and then came on to Hinckley where they met the other two machines full.

From then on they visited shops in Hinckley, Waterman, Shabbona, Shabbona Grove, Lee, Scarboro,



Steward, Rochelle, Lindenwood, Fairdale, Kirkland, Kingston and Sycamore. There were in all 18 in the party and they visited the shops talking and visiting with the workers and getting acquainted.

In all the company made a journey of 150 miles and one of the men reported today that he saw more well equipped and business like shops in DeKalb county than he has ever before seen in a day's journey.



## Benton's Recipe Book

**To Clean the Radiator** of the automobile an excellent solvent for the accumulations is a solution of concentrated lye. Mix just as much lye with one quart of boiling water as the water will take up. Then draw off a little over a quart of water from the radiator, if full, and pour the lye solution into the radiator. Use extreme care not to spill any of the solution on outside of car as it will ruin the car finish. Now operate the motor for about five minutes—not any longer—and then carefully flush out the radiator with clean, clear water. Several flushings may be necessary to remove all traces of lye.

**A Brass Polish**, at request of F. H. S., is made as follows: Three ounces of powdered rotten stone, two ounces of pumice stone, four ounces of oxalic acid and two quarts of rain water makes a good brass polish. The ingredients should be mixed thoroughly and allowed to stand for several days before using. Shake well before applying. A chamois skin or dry woolen

cloth should be used for polishing.

**On Ordinary Saw will Cut Cast Iron** if the iron is heated to a uniform cherry red. This is by no means a new idea as discussions on the subject are found in French and German periodicals of a century ago. Reference was also made at that time to the fact that cast iron can be readily filed with an ordinary wood rasp if heated to a dull red. Here are two chances for interesting experiments by those readers who are inclined to test out the apparently new ideas, though this case proves there is "nothing new under the sun."

**To Case Harden Steel** mix and thoroughly pulverize one part oxalic acid and two parts of common potash. Heat steel to cherry red, roll it in mixture, heat again in a clear fire and cool in water.

**Compounds for Welding** have been given almost without number in these columns. Here is one recommended for welding steel or iron: Mix ten parts of borax, one part purissiate of potash, one part sal ammoniac and about one-third of one part of bright, clean, iron filings. This mixture is reduced to a fine powder in a mortar. Then add enough water to make it about the consistency of heavy mud. Now place it over a wood fire and stir it until a material having the appearance of pumice stone is produced. This is pulverized to a fine dust and is used by sprinkling over the metals when they are at a welding heat.

**A Cement for Marble** is requested by H. M. K. This is somewhat out of our line but we are glad to help out our Vermont brother: Melt together eight parts of resin, and one part of wax. Then stir in and mix well four parts of Plaster of Paris. Heat the broken pieces before applying the cement and then press firmly together.

**To Temper Coil Springs**, in reply to G. T. C., try the following: Heat to cherry red and place in bath of crude oil, deep enough to cover spring well. Allow to cool and then heat again for about half or three-quarters of a minute and then put in water until cold. In heat a muffle will be better than the open forge. The muffle can be made of a piece of pipe large enough to admit the spring easily. Clean pipe well inside and out if rusted and bury it in the heart of the fire with open end out. This will serve well in place of a regular furnace, though if much of this work is done a furnace will be found best.



## Queries— Answers— Notes

**What Colors the Steel?**—We have a tank of salt water in the shop for case-hardening. There is some acid in it which gives color to the steel. I would like to learn through your paper or from some reader what it is that gives the steel the color.

JOE MURPHY, New Jersey.

**Smithing for 37 Years**—I have been getting your paper for some time and have found lots of help to me. I have been in the blacksmith shop for thirty-seven years, and I was only eleven years of age when I shod my first horse.

J. J. PETTIGREW, North Carolina.

**To Tighten Auto Wheel Channels**—In answer to W. L. Watson of Nevada, in the August number, take off channel and put thin shim of iron or brass width of felloe all around wheel. Place rim in fire and warm, not red hot. Then place on wheel and cool. Or, if possible, place wheel front side down. Around this, in three places, put three blow torches and when tire expands, slip in your thin strips.

JOHN DENBO, Illinois.

**Heat Treating Dies**—Where I work I see the die maker temper dies of about 10 pounds in weight. He takes them from the quenching bath sizzling hot, puts them back in the furnace to draw temper, and they seem to come out all right. I thought the steel must be kept in the water until cold, or the same temperature as the water. Will some brother tell me something about the above?

JOE MURPHY, New Jersey.

**A Drill Feed Improvement**—I was very well pleased with Mr. Bundy's stunt on the Mole tire shrinker that I will have to let you know about it. There are also a great many other things in our paper that are good. I happen to have a Mole shrinker and it has the same trouble but it will not have it very long now.

I have a No. 200 drill press and I made a very simple improvement on it, which possibly will interest some of our brothers. I will try to explain it. The weight of the dog that turns the feed had a tendency to push it back and sometimes would not take as many notches as it should. Take a piece of steel, about 1/4 or 7/8 or (something that will answer), about 11 inches long. Forge one end V-shape for the catch and put two holes for lag screws in the other end. Make the catch out of steel so that you can harden the end for wear, put it on the post on the left hand side, about two inches above the frame of your drill and you will have an improvement that will surprise you. It does not interfere with



THE WELL-BUILT NEBRASKA SHOP OF MR. J. T. SHEPHERD WHERE GENERAL WORK IS DONE



the other catch on the other side, but helps to hold the feed.

L. SMITH, California.

**Ford Wiring Diagram**—Through the pages of "Our Journal", would you please diagram the wiring of a Ford car; also the battery connections for same.

CARL D. HIXON, Tennessee.

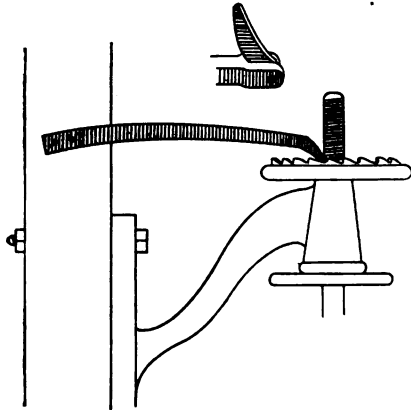

A DRILL FEED IMPROVEMENT BY MR. L. SMITH

**In Reply**—The accompanying engraving shows a wiring diagram for a Ford car. This diagram shows the wiring arrangement for both battery and magneto ignition with the switch for changing from battery to magneto.

F. J. S., New York.

**Two Shoeing Queries**—When I first began business here I was a bit of a greenhorn as regards running a shop, but with the assistance of your paper, I was soon able to find a remedy for the many obstacles that crept in my way. The practical experience of our fellow craftsmen, I am satisfied, is just what we want, and God knows we get it cheap enough.

The trade is getting much better in this country, the boys are getting sick of working for nothing. They are getting their heads together and turning down the cut-throat game. It is time, too,—the smile has been on the wrong side.

I would like some of our boys to tell me a correct method for forging a bar shoe. I have a way of my own, but I don't think it is fast enough. Also, how to shoe a pacer that hits the back of his front feet or the pads with the hind ones, or cross fires. He is perfectly round and a good, free mover.

W. MOYLE, New Zealand.

**An Interesting Letter from South Africa**—I like the paper immensely, as I find it very interesting and useful. It is nice to be able to keep in touch with brothers of the grand old craft the world over, even though we cannot actually see them. Trade in Johannesburg at the present time is very fluctuating. Nothing is really steady, although I'm told it is fairly steady in the Gold Mines. The life in the Gold Mines does not suit me, as there is too much drinking, although I'm not a teetotaler, I do not like to be mixed up with a drinking set. I prefer to work where I can have a choice of lodging, where I can feel homely and contented. There is a good deal of shoe turning being done at present in the City of Johannesburg as on account of the war, shoeing-bars and machine-made shoes are scarce. I was turning shoes last week for 17/0 (\$4.14) per 100 lbs. with a Kaffir boy to blow and

strike, and one day I made 118 lbs. Tomorrow I take on another contract with another smith at 20/0 (\$4.87) per 100 shoes. I'm after a job in an outside Gold Mine in the country. I prefer living in the country to the city as it is a quieter and healthier life.

L. G. REID, South Africa.

**Competitors that Work Together**—Business is pretty fair in this district but the war has taken a lot of the men away. We get good prices for our work and run our shop on a CASH BASIS. We have a good competitor and we pull together. Which is as it should be. If we run out of any articles we go to the other shop and are welcome to anything he has and if he comes to us he is welcome to what we have got and we try to help each other as much as we can. Coal used to cost us \$28.00 per ton, but we got together and got a car load in and made a saving of approximately one-half. If smiths would live and let live and get together more it would be to their mutual advantage. You cannot boost too much in your paper for the smiths to adopt a CASH system. It's a winner every time. If the banks won't trust a farmer with the money, then all the more reason why the smiths should not trust him. The majority of smiths would be in a better financial position today if they had NOT given credit. But they are a hard bunch to educate along these lines.

HENRY HOPE, British Columbia.

**Prices and Wages**—My experience as general blacksmith for a number of years has led me to this conclusion regarding prices and net earnings at blacksmithing: The greatest reason why there are so many men in the business who just exist, neither do they keep books to show what they are earning. Let us be business men and know these things.

I would like to hear from some of the brothers along this line, with figures showing what they are earning. I have an up-to-date shop and do general black-

The following are some of my prices: Sharpen plows, 50c to 60c; new shoes, 50c each; buggy tires, 75c each; sharpen lister, 75c; sharpen cultivator shovels, 75c set.

I should like to ask this question of the craft: What should be the net earnings of a man working alone as I am, and carrying on the business? This is a vital question, now don't all speak at once. Let the craft know what you are earning and it may be a help to the men in general.

NICK JACOBS, Kansas.

**From a Minnesota Smith**—I am a man, 41 years of age, and learned blacksmithing when I was 14 years old. I have been 27 years in the trade. Where I learned my trade nothing but coach wagons were made, and we turned out some of the finest work, hacks, hearses, couplets, etc. I also worked over five years in a navy yard as blacksmith and handled iron and steel up to two feet in diameter. I also served two years in the German army and worked one year in the gun shop. Here I am doing nothing else but sharpening plow-lays, shoeing horses, doing wagon and woodwork, and some other repairing jobs. The automobile has knocked my old trade in the head, but that is the way it goes. The world is going forward. Prices are good on the average, but could be better for many things in our territory. I would like to see the blacksmiths all over the United States get together and form a big association and better conditions in the trade. I think it could be done. And not only could selling but also buying business conditions could be different.

Before closing I want to tell a story. One night I met a clay digger in a store and he told me that he had worked in the blacksmith trade. After talking for a while he told me he could go right into my shop and show me some jobs that I would not be able to duplicate. I asked him why he was working in the clay pits if he was such a good blacksmith. Well,

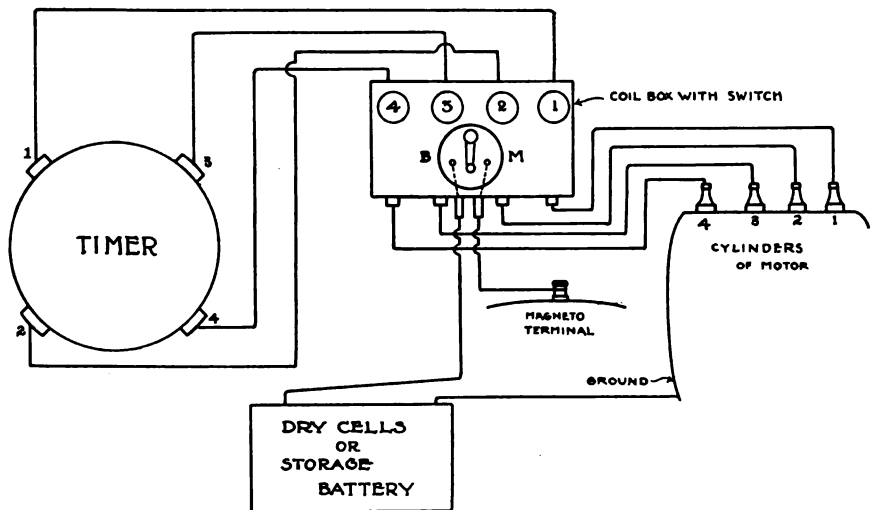

WIRING DIAGRAMS AS USUALLY ARRANGED ON THE FORD MODEL T CAR

smithing and horse shoeing. I work alone and am busy most all of the time. My prices are as good as the best. A number of my competitors are lower on much of the work. My net earnings were \$2.15 per day for last year. Now, if I have not made wages where will the price cutter come in?

he did not like it. After I listened to him for a while, I told him I thought if some blacksmith would hire him in the shop, his boss would be able to do without an important piece of machinery. He asked what it was, and I told him it was the blower.

H. DETTMERS, Minnesota.





## The Automobile Repairman

### Cooling and Lubrication Troubles

VICTOR W. PAGE, M. S., A. E.

A common cause of defective engine action during the warm weather is over-heating and when a motor gives indications of undue rise in temperature it is not possible to always discover immediately whether the defective condition is the result of improper mixture proportions, faulty lubrication or some fault in the cooling system. If the motor is overheating because the mixture is too rich this can be easily determined by studying the exhaust gases issuing from the muffler. If the gas has a pungent odor or if clouds of black smoke are being ejected it is reasonable to assume that the mixture is too rich. A thin mixture, or one that has too much air in proportion to the gasoline is also known to cause overheating. Whenever air is present in excess this is evidenced by "popping" in the carburetor. The remedy for either of these defective conditions is a simple one calling only for adjustment of the carburetor. Overheating is often caused by carbon deposits and when these are the cause the engine will not deliver its full power and will knock on the slightest provocation, such as hill climbing on the higher gear ratios. The way to tell if the trouble is caused by too much carbon is to remove one of the valve caps and study the character of the deposit on the undersurface. If the engine is a detachable head from the removal of a spark plug will suffice. If the parts removed show a coating of oily carbon it is reasonable to assume that the interior of the combustion head is also filled with a surplus of this material.

If an engine is overheating because of lack of oil it will knock much more than if the trouble is due to poor mixture or failure of the water circulation, and will lose power rapidly. This may be tested by turning the engine over with the hand crank and noting the resistance to engine rotation. If the cylinder is practically dry it will be found difficult to turn the engine over by hand and even the electric starting motor will not be able to turn the crankshaft at its normal speed. In many quarters, steam issuing from the radiator is considered an un-failing sign of defective cooling. This is not always so as in warm weather an engine which is cooled properly will cause the water to boil after a period of low gear work and there will be no real fault in the engine or the cooling system. If one's sense of smell does not locate the trouble in the carburetion system it is well to suspect some defection in the cooling group. It may not be anything of consequence as often a loose fan belt will result in over-heating. At the other hand if a pump circulation system is used there may be an actual mechanical failure of the water pump or its driving means.

Trouble is more apt to occur in the pump circulation system than in those where the natural cooling or thermo-syphon system is employed. As a rule the piping, and even the radiator passages of those systems in which a pump is depended on to force the water are of smaller size than the similar parts of the thermal system and are more susceptible to becoming clogged with sediment. The thermal system carries more water than the pump system which gives added insurance against over-heating and as the parts are very simple and the passages large, practically the only trouble that can occur are a serious reduction in water capacity due to leaks in the pipes or radiator or failure of the fan driving belt to drive the fan at the necessary speed. The form of radiator most generally used at the present time has a number of very narrow passages through which the water must pass in going from the upper to the lower tanks. The cooling water used in many localities contains foreign matter which is apt to create a sediment in the pipes. A powdery deposit or scale will collect on the inner surfaces of the radiator tubes and interfere seriously with the conductivity of the heat. A certain amount of rust will be unavoid-

able in the cooling system on account of the engine cylinders being of cast iron. This rust may get into the radiator piping or constrict the passage through some elbow or pipe fitting. Sand which has been left in the water jackets from the cores which were used in casting the cylinders is a further cause of trouble and may cause serious mechanical depreciation of a water pump, if it passes through it.

In order to remove all scale and sand from the cooling system it is advised that a solution of hydrofluoric acid and water be made, the proportions being about ten parts of water to one of acid. This solution should be poured into the water jackets and allowed to stand over night and care should be taken to disconnect the radiator so that none of the solution will find its way into that member where it will attack the brass of which it is composed very

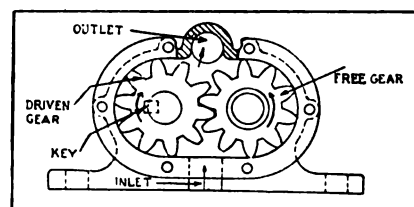

GEARED WATER CIRCULATING PUMP

easily. The cylinder jackets should be thoroughly flushed out with water under pressure to clear out all traces of the acid. The incrustation in the radiator, which is commonly caused by carbonate of lime, held in solution in the water will be cut by using a solution of caustic potash or washing soda. This will loosen many forms of deposit and will not have the same injurious action on brass that the acid solutions will have. The solution will work more quickly if it is brought to the boiling point before placing it in the radiator. After using any cleansing medium it is absolutely necessary to flush out the cooling system thoroughly with clean water under pressure.

Rubber hose forms an important item in the piping and while it is imperative to use the best quality for the purpose it is apt to deteriorate because a certain amount of oil and grease will find its way into the cooling system, usually from the grease cups used to lubricate the pump bearings. Of course, oil accumulations on the outside of the rubber hose are to be looked for. The effect of oil inside of the hose is to rot it and in the small diameter

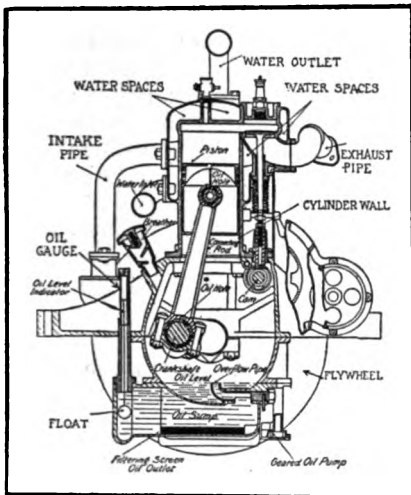

**SECTION OF MOTOR CYLINDER AND CRANKCASE SHOWING PARTS OF CONSTANT LEVEL SPLASH LUBRICATING SYSTEM**

hose used with pump cooling systems shreds of the inner lining may become loosened and restrict the bore of the hose, this causing a partial stoppage in the water flow. If anti-freezing solutions have been used in which glycerine is employed the hose is apt to rot quicker than if only clean water passes through them. Needless to say the cheapest remedy for defective rubber hose is to replace the faulty lengths with new ones.

If, for any reason, the pump becomes inoperative the circulation of water will be impaired. Two forms of circulating pumps are generally used, the centrifugal pattern and gear type. In the centrifugal form the water enters the pump center and is thrown outward by a revolving paddle wheel member, passing out of the case through an outlet pipe attached to the casing. In the gear pump the water can enter through either of two openings and as it cannot pass directly from the inlet to the outlet, owing to the fit of the gear teeth, it can flow only from one side of the case to the other by filling the two spaces of the gears and thus being carried around from one opening to the other. Anything that would interfere with the rotation of either the impeller or the gears will, of course, retard the circulation, because the water can not flow by thermal displacement, if the system has been designed for the use of the pump. At the present time water pumps are driven by positive means, usually by extension of the camshaft or driving shafts driven by positive gearing so there is little opportunity for failure of drive. However, if the pump has been used for some time

the steel shaft on which the impeller is mounted may become rusted enough so dirt in the pump will rupture the shaft. Very often the key or taper pin will shear off, this being very apt to happen if it has been strained due to the pump having been clogged by ice during the Winter season. The continual rotation of the impeller of a centrifugal pump or the gears in the other type will produce wear in the pump casing. This depreciation is particularly noticeable in the case of the centrifugal pump and if much space exists between the sides of the blades and the pump body there will be an opportunity for water to slip by and the pump efficiency will be reduced. In some cars a filter screen is interposed in the water line to keep dirt out of the pump. In performing this function the screen often becomes clogged with sediment and obstructs the water flow. Wherever a strainer is provided, provision is always made for removing it so it can easily be inspected and cleaned.

Excessive leakage at any part of water system that will result in loss of water will, of course, produce overheating. A point where considerable leakage may exist and which is not often suspected is at stuffing boxes on the pump shaft bearings and at the connections where the rubber hose joints the manifold. As the hose is held on by clamp fittings any loss of water at these joints may easily be prevented by tightening the clamp. The pump stuffing boxes, in most cases, can be screwed up so the packing will be compressed around the shaft a little more and the leakage at this point can be stopped. The radiator of an

automobile is rather a dilicate structure and as it has a multitude of soldered joints, the inevitable vibration due to car operation may strain some of these joints and cause them to leak.

Radiator repairing is an operation that requires more skill than the average repairman possesses, unless the joint that is opened up is at a point where it can readily be reached with a soldering iron. It is not difficult to seal open seams or cracked joints in the upper or lower radiator tanks, but it is difficult to seal a leak in the radiator interior especially if that member is a honeycomb type. In attempting to make repairs, the inexperienced mechanic using the usual form of soldering iron is apt to start more joints leaking in attempting to fix the faulty tube. Radiator repairing had best be done by specialists who are thoroughly familiar with this line of work. A number of compounds have been marketed that are intended to be placed in the radiator with the object of stopping the leak. These are usually of a glutinous nature and are soluble in hot water while at the same time they are of such a nature that they will solidify on striking the air and seal the crack. Compounds of this nature should never be used in a radiator that can be repaired by other methods and are a desperate recourse if the leaks cannot be stopped in any other way. If the leak is inside of a tube of a cellular cooler where it cannot be reached handily with any form of soldering iron, it is possible to fill the space around the tube up with some quick drying iron cement and thus prevent the leak. This is not a very good method as if a number of

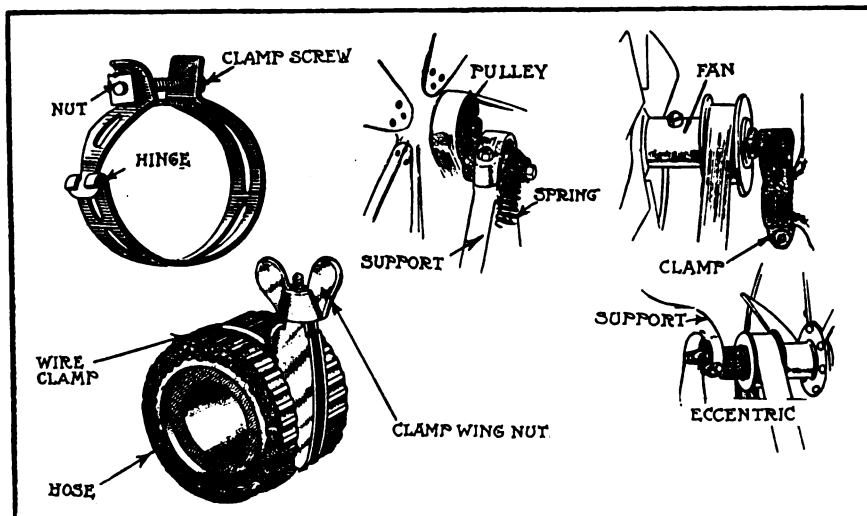

**HOSE CLAMPS AT LEFT, METHODS OF ADJUSTING FAN DRIVING BELTS AT RIGHT**



tubes are blocked up in this way the available cooling surface may become reduced enough to result in overheating. When touring, it is possible to make temporary repairs by plugging up the radiator tubes with wooden plugs and even chewing gum has been used in an emergency for this purpose. Very little serious trouble occurs in modern cooling systems and these are usually remedied without difficulty.

The use of poor lubricating oil or insufficient lubricating oil will produce the same overheating symp-

ptoms that defects in the cooling system do. The simplest method of oiling is the constant level splash system in which a supply of lubricant is carried in a pump integral with the crank case and the height of the oil in that member is indicated by some form of indicator. A pump draws the oil from the engine base and supplies it to splash chambers or troughs into which the connecting rods dip as they revolve. Surplus oil drains back into the crank case and is pumped through the system over and over again. The common trouble in a lubricating system is failure of the oil circulating pump. If this is a plunger type trouble may be found in the check valves. A piece of dirt under either the inlet or discharge check will render the pump inoperative. When the gear form of pump is used any

clogging of the filter screen or of the pump outlet with particles of dirt will, of course, retard the flow of oil. Where the oil passes through tubes of small bore in reaching the bearing parts the tubes may be stopped up by dirt or by particles of wax which are present in some oil. All of the trouble, practically, in the lubricating system can be traced to the use of dirty oil. The manufacturers' of all cars specify in their instruction books the intervals of time that should elapse between crank case draining operations. All

lubricant. On the other hand on old engines which have seen considerable service a heavier bodied oil will be valuable in filling up the excessive clearance between the working parts and of course, reduce much of the noise. Good gas engine cylinder oil is more expensive than inferior grades, but the oil consumption of the average automobile is so small that it does not pay to attempt to economize by using cheap oil. It will cost more to clean up the carbon deposits, due to the use of poor oil once a season than the

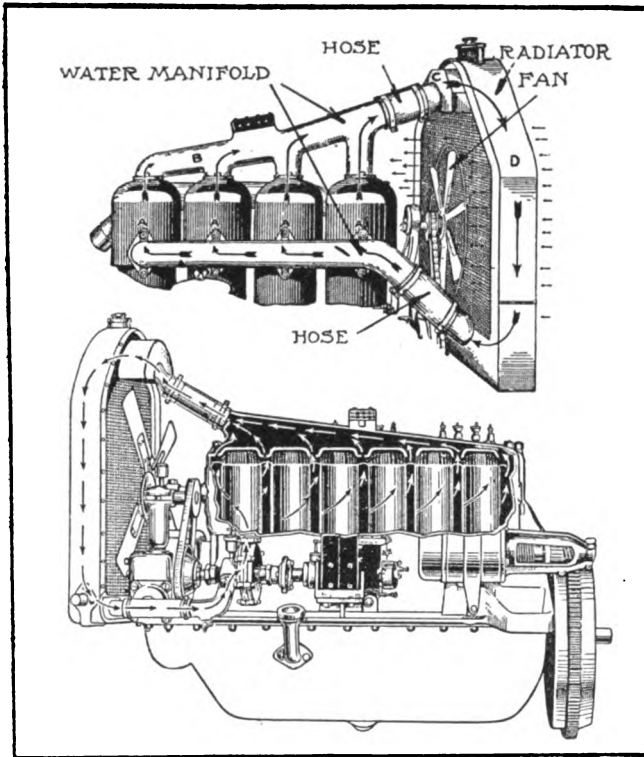

COMMON FORMS OF WATER COOLING SYSTEMS. NATURAL CIRCULATION AT TOP, PUMP METHOD BELOW

old oil should be washed out of the engine and new oil supplied from time to time. The usual rule is to clean out the oiling system thoroughly every 1,000 miles and if this is done and clean oil supplied no trouble will be experienced. The use of unsuitable oil, of course, cannot fail to cause trouble. If the oil does not have the proper viscosity, or body, the engine will not operate efficiently. In any oiling system where a number of tubes are used to convey the oil only those of light body should be employed because the heavy oils are apt to stop up the passages. On new engines or those that are tightly fitted a light bodied oil is much superior to a heavy body

difference in cost between good and poor oil would amount to in several years. The Correct Operating Pressure of a Tire can be determined without the use of a tire gauge. The weight of cars and the construction and weight of tires vary. The method suggested is to depend on the distention or displacement of the tire. When the car is loaded, measure the top of the tire and then inflate or let out air as the case may require, so that the bottom of the tire, the point which contacts with the road, measures about nine per cent. greater than at the top. This is the correct operating condition.

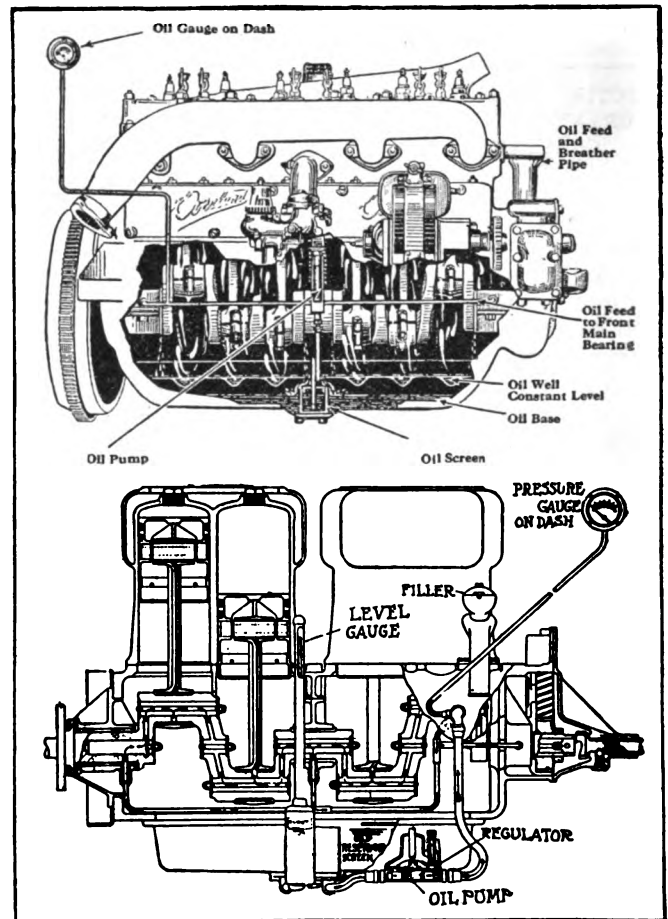

PART SECTIONAL VIEW AT TOP SHOWS OILING SYSTEM OF OVERLAND SIX MOTOR. BELOW THE PRESSURE FEED THROUGH OIL PASSAGES IN CRANKSHAFT OF MARMION FOUR CYLINDER

# TIMELY TALKS WITH OUR SUBSCRIBERS



The American Blacksmith is published monthly at The New Sidway Building, Buffalo, N. Y., U. S. A., by The American Blacksmith Company. Incorporated under New York State Laws. Entered, February 12, 1902, as second-class mail matter at Buffalo, N. Y., Act of Congress, March 3, 1879.

William F. Wendt, President  
 Associates: James Cran - Bert Hillyer - A. C. Gough - Dr. Jack Seiter

Albert W. Bayard, Secretary  
 Walter O. Bernhardt, Editor

Subscription Price: \$1.00 per year in advance, prepaid to any postoffice in United States or Mexico. To Canada, \$1.25; other countries, 6 shillings. Reduced rates to clubs of five or more on application. See "Honor Roll" page for money-saving, long-time rates. Cable address, "Blacksmith," Buffalo. Lieber's Code used.

Subscribers should notify us promptly of non-receipt of paper or change of address. In the latter case it is necessary that you give us both the old and the new address.

## THE LONG TIME RATES.

You can save money, time, trouble and worry by subscribing for THE AMERICAN BLACKSMITH for a period of two or more years. Our Long-Time Rates and Our Honor Roll go hand in hand, and the greatest advantage offered by the combination is the money saving that is possible. Don't lose sight of that. Any way you figure it you are certain of a saving in your subscription money. And the amount you save is limited only by the amount you want to save. Is there any reason why you should not take advantage of these savings? Look up our long-time rates now, and then send in your subscription order and remittance for a term of years. The subscription department will advance your subscription accordingly and advise you.

## AUTOMOBILE WORK.

Almost every day brings us news of more smiths adding automobile work to their line. And there is every reason for the vehicle worker and general smith to take on this work, but you cannot do it without knowing something about the automobile, the tractor and the truck. A good, practical general smith can learn a whole lot about these vehicles from a few well chosen practical books on the subject. Get in touch with our book department, they have several excellent books on automobile subjects and they are anxious to explain and describe these books to you. Prepare now for the automobile work you will do next spring.

### Subscription Agents

When a stranger solicits your subscription to THE AMERICAN BLACKSMITH or any other publication, insist upon him showing you absolute proof that he is an agent in good standing and is employed by the publication which he represents. Don't under any circumstances give the man your money if you are not sure that he does. No matter what the man he really works for the paper he says offers you—no matter what price he makes—no matter what premium he promises to send—Don't Give Him Your Money If You Are Not Sure.

## Contents, November, 1916

New Feed for the Bird—Frontispiece	28
Laminitis and How to Shoe the Laminitic Foot .....	29
The Horseshoer .....	30
The Horseless Farm not yet a Reality .....	30
How I Built Up My Shoeing Business ..	30
Navicular Disease .....	32
Making Socket Wrenches Under Steam Hammer .....	33
Wrought Iron Gate Ely Cathedral England ..	34
Striping Pigments .....	35
Henry Hinkins—Veteran Blacksmith Standardization of Axle Spindles, Axle Boxes, Wheel Hubs and Flanges...	37
Nowlan's Aeronautical Ship .....	38
Don't Place Fire Insurance with Anybody you Don't Know About...	38
The Smith in The Daily News.....	39
Blacksmith Appointed Sergeant..	39
Blacksmith Boxing Champion.....	39
Bends Steel Bars Like Wire.....	39
Blacksmith Has Toe Broken.....	39
Kicks Blacksmith to Death.....	39
Blacksmith May Lose Hand.....	39
Injured by Man he Befriended.....	39
The Wise Guy—Verse.....	40
Heats, Sparks, Welds .....	40
Our Honor Roll .....	41
The Depreciation of Packing Material Used in Case Hardening.....	42
Notes on the Theory and Practice of Hardening .....	46
Benton's Recipe Book .....	47
Axe Dressing, Hardening and Tempering .....	47
Another Welding Compound .....	47
Hard Putty .....	47
Queries, Answers, Notes.....	48
Tractor Plow Construction and Adjustments .....	48
A Letter from New Zealand .....	49
A Straight from the Shoulder Talk The Automobile Repairman.....	50
Painting the Automobile Quickly and Cheaply .....	50
Converting a Horse Drawn Hearse Body to Fit an Automobile Chassis .....	51

## HOW "OUR JOURNAL" WORKS.

When a publication gets right down to rock bottom solutions for your problems, you know that such a publication is the one you want to read and to study. Sound, practical articles by practical men has been the policy of THE AMERICAN BLACKSMITH since the beginning. Theories are all right and have their place, but practical men want practical articles, they have practical problems to solve. THE AMERICAN BLACKSMITH gets right down to the job, with the why, the how and the wherefores.

As one subscriber said in a recent letter: "I received my copy of 'Our Journal' on Tuesday, I read it Tuesday evening. On Wednesday I applied two of Benton's recipes and the automobile department solved an automobile problem for me Wednesday afternoon."

That is how "Our Journal" works, tells you how and then shows you how. THE AMERICAN BLACKSMITH pays its readers because its pages are heaping full of sound, practical shop information that you can use today on today's job.

## YOU CAN HELP.

Can you use a rubber stamp, bearing your name, business and address and an inking pad in your business? Or would you prefer a genuine leather bill fold and card case? We will gladly send you either one, as you prefer, if you will help us to increase the number of readers and subscribers to THE AMERICAN BLACKSMITH. Surely you know one other smith who will find profit and pleasure in "Our Journal." Surely you know of one smith who will be glad to subscribe when you tell him about "Our Journal." Call on your neighbor smith today and get his subscription order, or if you cannot call on him personally, write a letter; we will make it worth your while.

When you send us the new subscriber's name and address and his remittance, tell us which present you prefer, whether the rubber stamp and inking pad, or the bill fold. If you send in two new subscribers, ask for both presents. Can we count on your help to double our list?



**NEW FEED FOR THE BIRD**

You can no more keep your volume of trade up to standard and increasing on gradually diminishing sales-per-customer, any more than you can fatten a Thanksgiving turkey on short rations. If you find your volume of trade diminishing, and your profits thinning, use the new feed—automobile repairing. It is keeping the volume-of-trade bird fat, and growing for many smiths. It is putting new life and energy into many a faltering business. If your conditions are right—if your trade warrants—try some of the new feed for fattening your volume of trade.



# Laminitis and How to Shoe the Laminitic Foot

E. W. P.

THE shoeing of foundered pumiced or drop-sole feet frequently proves a difficult problem for the average shoer, but since the principal difficulty is the result of ignorance on the anatomy of the foot and the disease known as laminitis, an article on the subject may prove of service. Laminitis is an inflammation of the sensitive laminae of the foot, it may be acute or chronic. It is most frequently met with in the acute form though it may develop slowly. I have known some horses to develop a laminitic condition of the front feet without being lame enough to lose a single day's work.

The most prolific cause of laminitis—founder—is inflammation of the mucous membrane of the bowels or lungs. A horse may get inflammation of the bowels from drinking very cold water while overheated or extreme overeating when an inflammation of the stomach may cause laminitis. The sensitive laminae is a continuation of the mucous membrane of the pulmonary and digestive organs, and experience proves that inflammation in the one organ is very prone to spread to the other. We, therefore, frequently see laminitis as an after effect of pneumonia, enteritis or a protracted case of colic, or it may result from a long journey on a hard road, especially if following a period of idleness. The coarser breeds of horses with heavy lymphatic bodies are more prone to the disease than finer bred stock.

The symptoms of acute laminitis are very characteristic. The animal stands with the hind feet well under the body, while the front legs are extended. The toes of the feet are elevated and the heels only touch the ground. This peculiar position is the result of an effort to get the weight of the body off the front feet as much as possible. There is also a high fever with a quick pulse, and the face is expressive of great suffering. The body is bathed in profuse perspiration and the slightest

tap on the affected feet causes great pain to the animal.

Of course, the treatment of such requires the professional skill of the veterinarian, though an outline of the pathology of the case is of value to the shoer because of the after treatment for which he will be called when the surgeon has cured the acute symptoms. During the progress of the disease the congested laminae, see 14, Fig. 1, exudes serum around the toe. The unyielding nature of the wall does not admit of any swelling that would relieve the intense pain, thus the pressure of this exudation separates the sensitive from the insensitive laminae and forces the coffin-bone downwards. This causes the structural changes in the foot, and seen in Fig. 2. In a few bad cases the toe of the coffin-bone is forced through the horny sole of the hoof. As an after effect of this serious disease the sole of the hoof becomes flat or even convex. The growth of wall from the coronet is slow, while the growth of soft horn from the sensitive laminae is excessive. The foot grows hardly any heel, while the toe is abnormally long, as seen in Fig. 2. The outer wall grows irregular rings,

and there is an abnormally developed frog. The laminitic horse has a peculiar gait so characteristic of the disease that horsemen can discern it afar. In an effort to save the toe (the injured part), the horse elevates it, sets the heel on the ground first and walks in a heel and toe fashion. Those animals that have had severe attacks are fit only to plow.

It is truly wonderful what a marked improvement will result from proper shoeing, and this is why I have taken the space to elaborate on the causes and symptoms of the disease, believing, as I do, that a knowledge of the same is indispensable to the correct shoeing of such feet. It is common to see the shoes of laminitic feet worn off at the heel, while the toe is almost as thick as when the shoe was put on. This heavy wear at the heel is the result

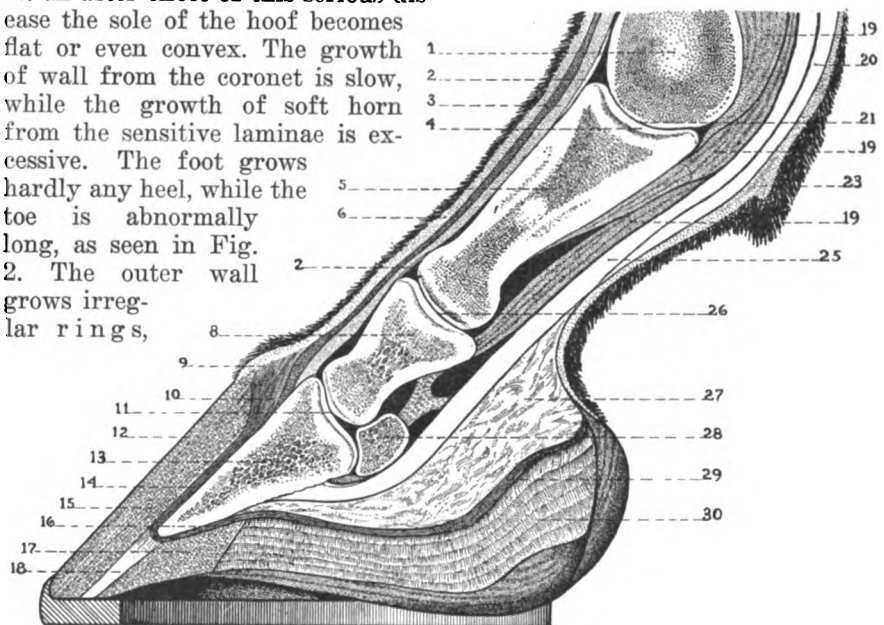

A SECTIONAL VIEW OF THE HORSE'S FOOT

- |                          |                                    |                                   |
|--------------------------|------------------------------------|-----------------------------------|
| 1—Cannon bone.           | 12—Periople.                       | 21—Fetlock joint.                 |
| 2—Capsular ligament      | 13—Os pedis.                       | 22—Brgot.                         |
| 3—Extensor pedis tendon. | 14—Sensitive laminae               | 23—Flexor pedis perforans tendon. |
| 4—Articular cartilage.   | 15—Horny wall.                     | 24—Pastern joint.                 |
| 5—Os sufraginis.         | 16—Sensitive sole.                 | 25—Plantar cushion.               |
| 6—Skin.                  | 17—Horny Sole.                     | 26—Os navicularis.                |
| 8—Os Coronae.            | 18—White line.                     | 27—Sensitive frog.                |
| 9—Periopic ring.         | 19—Sesamoidian ligaments.          | 28—Horny frog.                    |
| 10—Coronary band.        | 20—Flexor pedis perforatus tendon. |                                   |
| 11—Coffin joint.         |                                    |                                   |



of the animal trying to save concussion on the toe (the seat of pain). This undue concussion at the heels impedes the growth at that part and

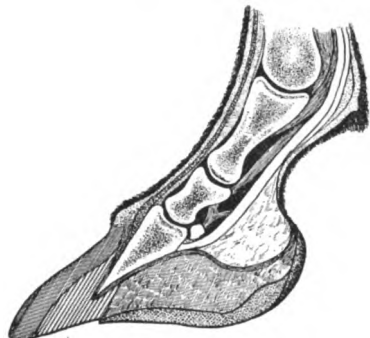
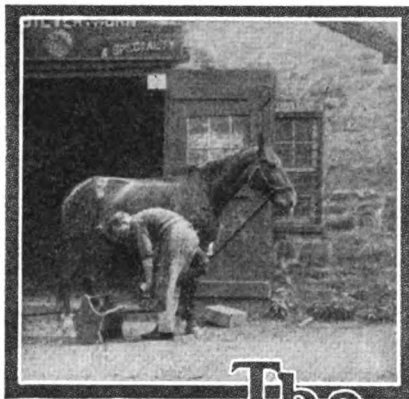

FIG. 2.—THE LAMINAE SEPARATES AT THE TOE

as a result the heels of such feet are very low, but the frog grows abnormally high. Here is where scientific knowledge comes in. The unscientific shoer thinks that the tenderness is in the frog instead of in the heels and sole. So to keep the frog off the ground he uses high heel calks, which imposes great weights on the tender heels, and by thus elevating the heels of the foot, he throws the weight of the horse on the toes, thus adding greatly to the discomfort of the animals.

Do not try to raise the heels to the normal height of a sound foot, the heels of laminitic feet are naturally low. The sole is already very thin. Don't make the mistake of paring this away or you may cut it through. As a rule, there is little or nothing to cut off the wall at the ground surface, but the toe will need rasping back at each shoeing. The correct way to shoe laminitic feet is with bar shoes and leather or rubber pads. If the feet have been shod with high heels for some time the heels of the feet will be low and the frog high. For the first shoeing, arch up the bar of the shoe and weld a slug on each heel. Put plenty of nail-holes all around the shoe—toe included—seat out, concave the shoe so that the tender part of the sole is relieved of weight. Then roll up the toe of the shoe and fit the shoe so as to get but little weight on the frog, because this organ being so long deprived of its natural function, will stand but little weight at first. At the next shoeing you will find that the heels have begun to grow, while at the same time the frog has begun to sink back to its natural position. At the third shoeing you may put equal weight on heels and frog, and as you lower the

bar at each shoeing hammer the slugs lower at the same time. When the frog has sunk back level with the heels, leave the slugs off altogether as all laminitic horses travel with much more comfort without calks. In some cases it may be necessary to weld a plate across the shoe to protect the sole from injury by the projections in the road. Always use leather soles with tar and oakum. In shoeing an animal that has only just recovered from an acute attack, don't be disappointed because the improvement is slow, it takes time for nature to complete her repairs, but by carefully following the instructions you may make a good worker of many a horse that is otherwise useless.



## The Horseshoer

### The Horseless Farm not yet a Reality

When the horseless farm will be a reality no one can predict. Many changes and many improvements in tractors will need to be made before gas power will be able to do everything on the farm. That it is doing several things better than the horse is not denied. For example, here is an item from the *Prairie Farmer* telling of tractor work:

"Many farmers have wondered whether or not the purchase of a tractor would enable them to get along with fewer horses. Here is Brother Leo's experience, as he told it to me a few days ago. He bought an 8-16 tractor of standard make last spring. At about the same time he sold a four-horse team of first-class draft colts for \$1,000. This was over \$200 more than the cost of the tractor. The colts could not have been sold if the tractor had not taken their place. As a matter of fact, Brother Leo says, the colts could not possibly have done as much

work as the tractor did.

"This is the experience of a practical, hardheaded farmer, who keeps a pure-bred Percheron stallion and

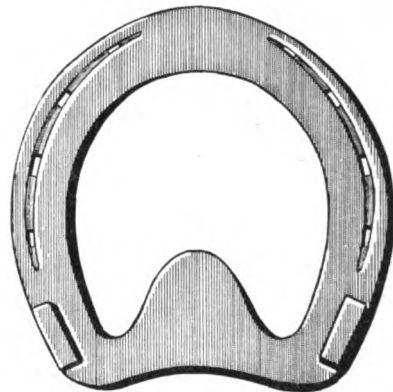

FIG. 3.—A BAR SHOE WITH A SLUG ON EACH HEEL IS USED

makes a good deal of money raising draft colts. He is not prejudiced either for or against the tractor. His opinion is that a combination of tractor and horses makes the best and most economical power equipment for the farm."

The horse is still a necessity on the average farm. He will no doubt have a place for some time to come. But never-the-less his "going" to give place to the gas power machines so far installed has caused a great many smiths to "take notice" and to seriously consider the painting of a new sign.

### How I Built up my Shoeing Business

J. R. WEST

It is hardly necessary for me to go into the details and tell you why and how my shoeing business decreased year by year. The average shoer who is honest with himself will not need to have these details impressed upon him. It is sufficient to say that I watched my shoeing business like a mother does a sick child. I kept my fingers constantly upon the pulse of my shoeing trade, and noted carefully its variation and how it at times made a high total only to fall down hard the next succeeding week or month.

Naturally, it was borne in upon me, that there must be a reason for this condition of affairs. In looking into the matter, I made up my mind to be open and honest with myself in looking for the real cause, and to let nothing stand in the way of my getting at just exactly what was causing this result.

Many horseshoers, for sentimental



reason, will argue from now until St. Peter blows his trumpet, that the automobile and truck are simply fads, and that the horse is again coming into his own. I started out to solve my problem with no such sentimental ideas. I made up my mind to get at the foundation of the matter, and to look this problem squarely in the face.

Naturally, therefore, I was ready to give the automobile, tractor and truck full credit for everything they were doing to the horse and horse interests. And while I found that several conditions in the trade was directly traceable to the automobile, there were other matters for which the motor vehicles were only indirectly responsible.

For example, I found very naturally that when a horse owner purchased an automobile he usually sold at least one of his horses, and in the majority of cases two or three. In addition, his new purchase of the motor machine seemed to take up so much of his attention that he usually failed in his usual good care of his horse stock and his horse vehicles. I have seen this very same thing work out so often that I now look for it the minute I hear of anyone of my customers purchasing an automobile. It is strange that this should happen, but it is true, nevertheless. A farmer, or small merchant who has taken extremely good care of his horses and vehicles and has even taken pride in the appearance of his animals and wagons, will, nine times out of ten, after he has purchased an automobile or a truck, become careless in his attention to both horses and wagons which, in some cases, borders upon downright neglect. So much for the automobile situation and how it affected the business of shoeing horses.

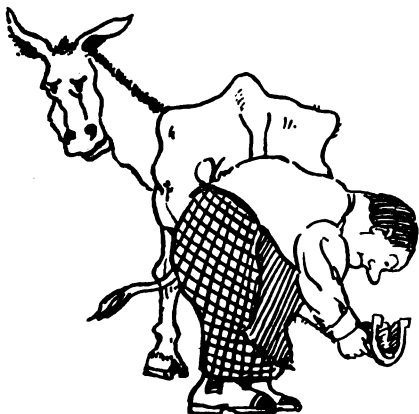

FINGERS ON THE PULSE OF SHOEING TRADE

In addition to the above I found another situation which had a bearing upon the total amount of business done at my shop. This was the repairing and, in a few cases, the shoeing done right on the farm in the farmer's own shop.

Now, let us look through the shop books, and see just how the above causes affected the business from a money standpoint. In the case of the merchant—the grocer, butcher and dry goods store keeper in town—from whom I could count upon from \$50.00 up, per year, depending upon their horse equipment, for shoeing and repairs, I found this sum cut down to nothing, when the merchant used autos exclusively. In the case of the farmer, when he replaced his family carriage with a touring car, the driving horses were sold and the carriage either followed suit or was allowed to fall into decay, where before the carriage was

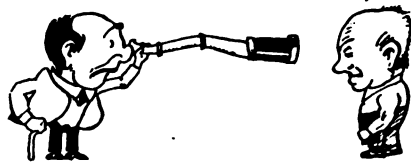

LOOKED THE PROBLEM SQUARE IN THE FACE

brought in for its periodical overhauling and repairing and the horses naturally had to have their feet attended to regularly. Naturally this hit me hard. A solution must be found and found quickly before it was too late.

I first considered the matter of going into the automobile repair business, but this ambition was soon killed after an investigation of the situation I found that of the three garages already established, two of them were doing an excellent business, while the third was doing fairly well. All of these garages had repair shops in connection with them, one of them being especially well equipped for doing all manner of automobile repair work. The automobile repair business was, therefore, not called in to the rescue. The real solution to my problems was actually suggested by one of my customers.

A farmer, living several miles out of town, had been bringing me his horses and wagons for a number of years. We were good friends. He knew something of the situation as I have detailed it here. One day he came in with a horse that I have been treating for him, a horse which

he had recently purchased and which was troubled with contracted heels. I had been somewhat successful in treating this trouble, and as I



LOOK THRO' THE SHOP BOOKS

was repacking the horse's feet and spreading his heel, this customer surprised me with: "Jim, why don't you take up the treatment of horse's feet as a specialty. There should be good money in it and perhaps you can build up a practice that will make up for the loss which you have been telling me about!"

This set me to thinking, and finally to planning what today is proving to be the salvation of my shoeing business. I specialized in the treatment of horses' feet, and unnatural gaits, and while I am not becoming a millionaire at the game, this line of work is making up in good part for the business and trade which has been lost through the natural conditions produced by modern progress.

While I have been a horseshoer all my life, and thought I knew all there was to know about it, I have again become a student and have studied not only the shoeing of horses, but anatomy and general diseases as well. This has not only enabled me to intelligently correct foot troubles, but in many cases, has caused my customers to call me into consultation upon other horse matters having no relation whatever to shoeing or the feet. I have advertised at every opportunity and have let customers and others know that I specialize in foot troubles and faulty action. Every successfully treated case is just another good ad for me and I see that it gets noised about.

In specializing upon the treatment of horses' feet, I have naturally attempted to put it upon a systematic basis such as I have prided myself upon doing in the shop ever since I have owned one. I accordingly





planned a form which I use in taking care of those cases which need more than casual attention. This enables me to keep a careful record of each case and leaves nothing to guess work, which is important when a certain line of treatment is to be administered.

Besides making a study of general horse diseases I have also made a collection of recipes and formulas for use in the various foot troubles and horse diseases. I am therefore able to make up my own salves, oint-

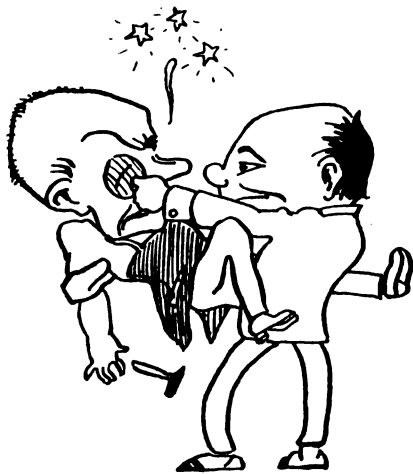

THIS HIT ME HARD

ments and liniments and in cases where they are needed I fix up the proper mixture so that the horse owner can help along my treatment of his animal by the proper care of the animal in his own stable.

Of course, you are asking if you can do the same as I have done—if you can prop up your business in the same way. This answer depends entirely upon your local conditions. You can no more solve your problems the same as I did without considering your exact conditions, any more than a physician can administer medicine without considering his patient's disease. I have simply told here how I rebuilt a tottering business. How long it will stay rebuilt it is impossible to say. If the auto, truck and tractor continue to grow in popularity in this section the number of horses will decrease. I hope, however, that before the auto overtakes the horse entirely, that I will be able to retire.

### Navicular Disease

Its Symptoms, Causes and Treatment.

Navicular disease in an inflammation of the navicular region, which commences sometimes in the tendon-sheath (navicular sheath) and sometimes in the bone itself, which in

many cases, becomes serious.

It is a disease more especially of the fore feet, and of light horses; draught horses being seldom affected. It is more commonly seen in harness-horses than in hunters, or horses used entirely for the saddle.

It is less common in this colony than in the older countries, but I have seen many cases of it here, and it is a disease which is of considerable importance to all horse-owners.

The navicular bone derives its name from its peculiar shape, which is somewhat that of a boat. "Navicula" is the Latin term for a boat or small ship, from navis, a ship. This little bone is contained within the hoof, and articulates with the coffin-bone on the one hand, and the coronal bone or bone of the coronet on the other. It presents a smooth surface for the great flexor tendon of the foot to play over, it supports a little tendon-sheath (the navicular sheath, which is lubricated with a fluid analogous to joint-oil), and by its position it gives strength and solidity to the last joint of the limb without impeding, but rather favoring, free movement.

The navicular bone is held in its place by powerful ligaments, some of the most important of which are covered by cartilage which is an extension of the cartilage on the posterior face of the bone. This fact is of great importance in enabling us to understand some of the phenomena of navicular disease, because it shows how any severe strain or injury to these ligaments may react upon the cartilage covering the bone and so upon the bone itself.

#### Symptoms

In the earlier stages of navicular disease there is, as a rule, but little lameness, the first indication of its presence being that the horse "points" the affected foot—that is, he extends it in front of him while standing. This pointing is altogether different from that which we see in some horses which have nothing the matter with them, except fatigue, or that tired feeling without work which affects some horses, as well as

men, occasionally. In this case a fore and a hind limb of opposite sides are rested and bent, but in navicular disease only the affected



I SPECIALIZED

fore foot or feet are "pointed." The knee is kept rigid, and the heel rests upon the ground. Similar pointing to this also occurs in pain from corns, side-bones, splints, etc. After a time lameness is manifested, usually coming on for a few minutes and going off again during work. As the disease progresses the lameness lasts longer and longer, until the patient is lame all one day and sound the next, then lame for a week at a time; and at last he becomes lame constantly.

The lameness of navicular disease sometimes first manifests itself (altogether the disease has been in progress some time) after shoeing, the jar inseparable from the ordinary nailing-on of a shoe having determined it. In such cases the shoeing-smith sometimes gets the blame of having lamed the horse.

In the lameness of navicular disease the affected foot comes to the ground after a very short step with the toe first, and as this part of the foot cannot by itself bear weight for any time, and the heel is too tender to do so, the weight is very quickly taken off the limb altogether.

After navicular disease has been in existence for some time, certain changes take place in the conformation of the hoof, which consist mainly in the foot becoming more upright and blocky, the heels and frog contract, and the sole goes up and

James Brown, 328 Smith St.				"Bill"—Bay Horse. Contracted Heels.
DATE	TREATMENT	SIZE OF SHOE	CONDITION	REMARKS
Sept. 15	set of shoes packed front	No. 4		expanded heels to 1 7/8 inches.

I THEN PLANNED A FORM WHICH I USE IN KEEPING RECORDS OF TREATMENT.



becomes more concave than it normally should be. The hoof is usually dry and hard. There is often some heat about the heels, especially after work, and in some cases pain is manifested on pressure in the hollow of the heel.

As you will notice, there is no one positive symptom of navicular disease; but to those accustomed to deal with it, the action of the horse

known as a thing to be avoided by all experienced breeders of horses.

An acquired predisposition is brought about by bad shoeing or the unnaturally dry condition of the horn which is induced by continued standing on hard stable floors. The principal faults of shoeing which induce such a contraction of the foot as predisposes it to navicular diseases are the continuous cutting-

sole, is very great in healthy feet, but especially so in such as are predisposed to navicular disease.

**Treatment**

This disease is only curable in the early stages, as when the bone is carious or the tendon-sheath, is obliterated, we can hardly, from the inaccessible position of the bone, expect to do much good. Cases must be treated according to the condition at the time; but so far as general principles are concerned, the wall of the heels usually requires to be shortened considerably, and the feet kept constantly wet, either by standing in cold water or by placing the horse in a damp meadow.

A blister around the coronet is frequently useful.

**Making Socket Wrenches Under the Steam Hammer**

BERT HILLYER

In answer to the reader who wants to know how to make the socket wrenches under a steam hammer with special tools; if he tries those made as shown in the engraving he will find he can turn our wrenches very rapidly and accurately. This tool makes the head part only, with sufficient stock to weld a handle on. To make the tool, a piece of steel is machined out as shown by dotted lines in engraving at C, and four pins placed to hold the plate that guides the punch on top. The punch should have a slight taper as should also the hole in the block where the head is formed, so that it can be driven out easily.

To make the wrench head a piece of round stock is heated long enough to block off two or three pieces as at E and B at one heat. The tool, E, that necks and partly cuts off the blank, is a spring side fuller that the writer explained some time ago. The blanks are then heated up to a good heat and one taken and dropped in the tool, the plate put on, and the punch dropped in the hole of the plate or guide. One or two quick blows drive in a recess for the nut and also lengthens out the stem to the depth the punch went in. This metal had no other place to go so naturally squeezed out of the smaller hole in the bottom, thus lengthening the stem and the result is a nice socket wrench in two heats and when a number is made it is less. At A is shown the tool with piece ready to be driven in. The blank stock is shown at B while at D is shown the finished socket head.

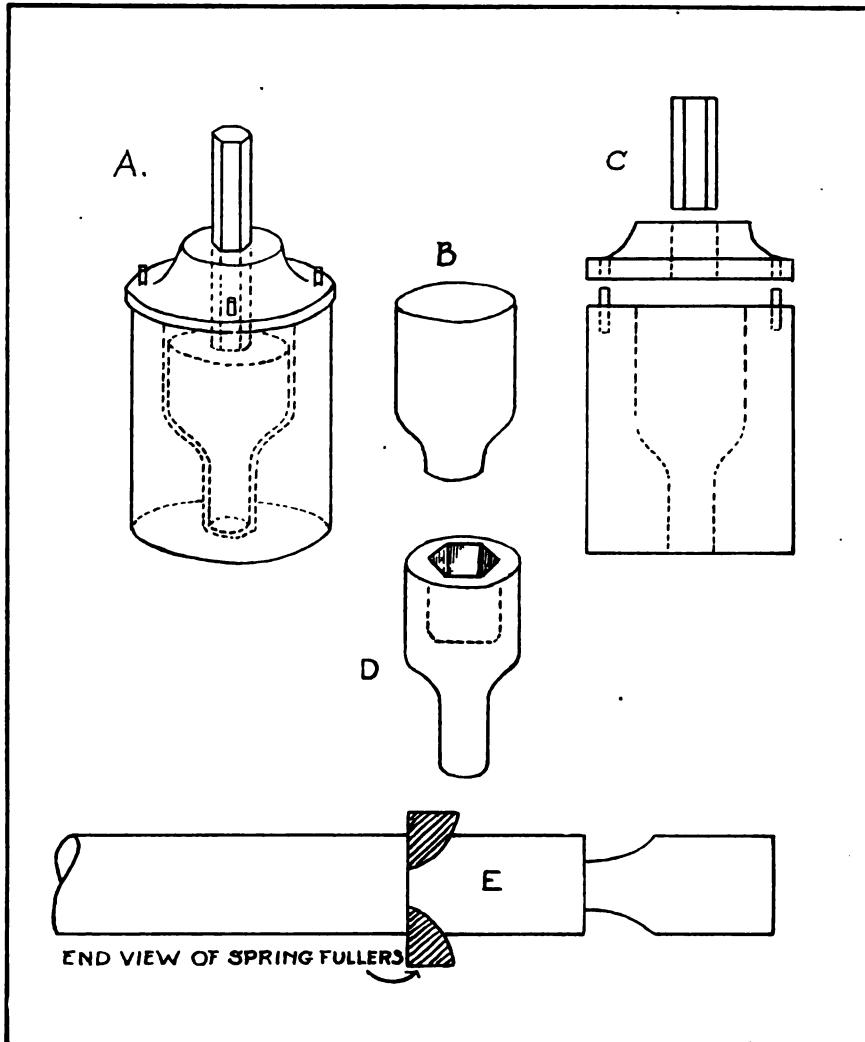

MR. HILLYER TELLS HOW TO MAKE SOCKET WRENCHES QUICKLY UNDER THE STEAM HAMMER

is of the greatest importance in the earlier stages, and in the later the action together with the changes in the conformation of the hoof.

**Causes**

The causes of navicular disease are of two kinds, predisposing and exciting.

The predisposing causes are either hereditary or acquired.

The hereditary taint, which is indicated by a small, narrow, hard frog, abnormal dryness of horn, high heels, narrow upright feet, and a small plantar cushion, is well-

away of the frog and bars, weakening of the sole, "cleaning out" the heels, and the confining of the bearing surfaces to the wall only.

The principal exciting cause of navicular disease is the concussion to which the feet are subjected in overfast or continued work on hard roads. Such concussion is very likely to determine the disease where any of the predisposing causes are present.

The necessity for absorption of water by the under-surface of the wall, the frogs, the bars, and the



### Wrought Iron Gate, Ely Cathedral England

JOHN Y. DUNLOP.

English ironwork differs in many ways from the ironwork found on the continent. The foreign craftsman for example covered his work with ornament which although adding something to its artistic effect was very often detrimental to its practical use. The English craftsman on the other hand considered first the purpose for which his work was to be used and having constructed with this object in view, then ornamented it as he thought fit. In this way it happened that gates and railings consist of the most part of vertical and horizontal members with scroll work in panels ornamenting the spaces between.

In many of the oldest examples the upper portion of these gates were ornamented with scroll work showing both double and single leaf work which was generally welded to the scrolls thus producing effects in ironwork that was very pleasing to the eye, was artistically correct, and was strong enough to last thro years in a changeable climate. Unfortunately only a few of those specimens remain at the present time, yet the number which still exist give a good idea of the work that was accomplished by the old blacksmith.

In the illustrations are shown one of the gates at Ely Cathedral which was made about 1575. The double gates are hung in a wrought iron frame which is fixed into a recess in the masonry jamb.

The design of the gate is quite in keeping with the style of architecture of the period at which the building was erected and goes to show how much attention must have been paid by those early art craftsmen to have those metal gates forged to show the minutest details of Gothic work. The outline of the gates follow the formation of the gothic opening which is divided by the meeting rails and the horizontal parts of the frame into a series of panels.

In the first of those members we have a very pleasing example of pierced metalwork. This part is formed by a top and bottom rail which are grooved to receive the small metal plates between. Each half door has eight of these small panels cut to represent gothic tracery with the shaped outlines slightly splayed on both sides. At there vertical joints they butt against the vertical parts of the sole rail which

are welded with their diagonals parallel to the front of the gate. The same arrangement is adopted with the vertical members of the lower panels.

In the lock rail which is shown in the line drawing the moulded rails which receive the double metal plates form part of the frame of the gate. The plates throughout there entire length are finely stamped and are a beautiful example of hammered wrought iron work.

From the top of the lock rail springs the pointed tracery work with its ornamented infilling. The section of the metal for the principal members of this part are square with there sharp arrises toward the face and the back of the door and as each of the members are grouped they receive the twisted vertical bars which are such a pleasing part of this panel. The design of these members are shown in the drawing with a section at the middle which shows that they consist of three fine-

ly drawn cylindrical bars which are twisted and forged into a shaped end at top and bottom. From each of these there seems to spring a four centered gothic arch in iron which internally is filled with two cusps and in the spandrils is divided by a twisted vertical bar forged out of the solid.

All these members grouped together convey the impression of a very fine piece of forged gothic tracery work connected to an ornamental horizontal rail from which the gothic head of the door springs.

The frieze rail is composed of one bar square on the back and semi-circular on the front with a twisted ribbon ornament cut out. At each point of intersection of the tracery and the rail a double flower ornament is studded on. Above this rail the panels are filled with scrollwork of excellent execution which gives a light and pretty effect when compared with the architectural lines of the lower panel.

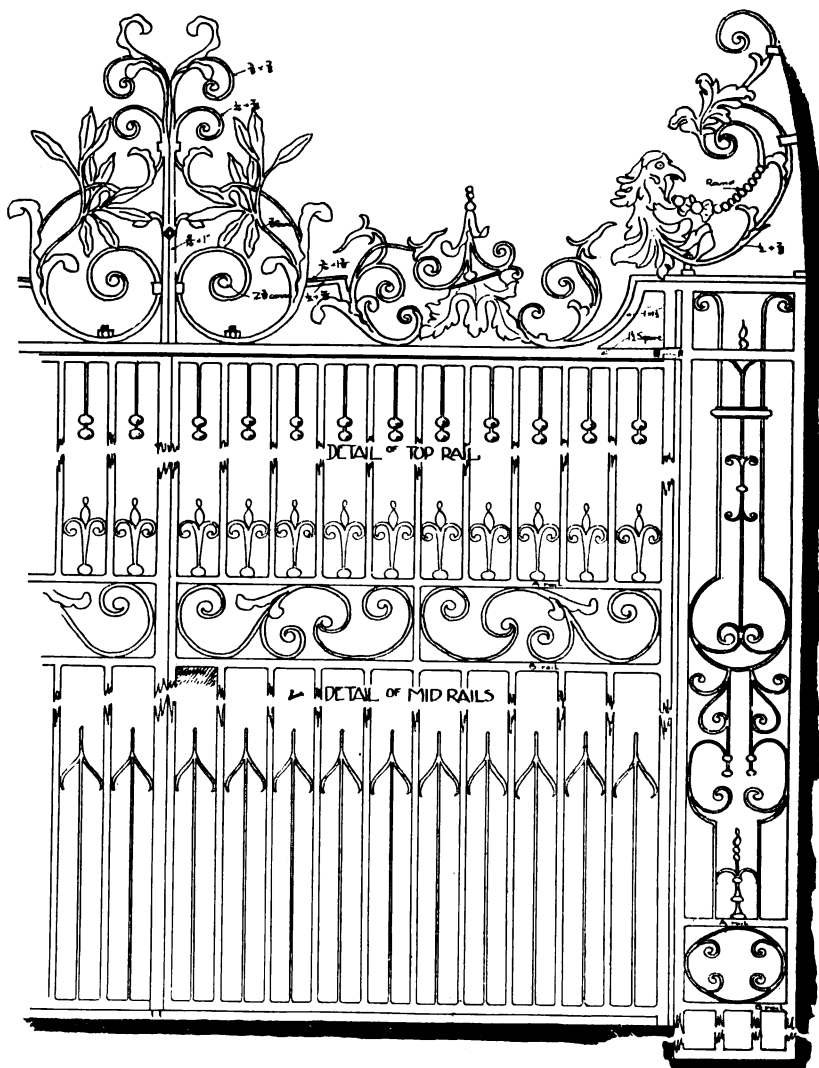

DETAILS OF EIGHTEENTH CENTURY GATE OF FENCE, YORKMINSTER ENGLAND



## Striping Pigments

### Methods of Mixing and Using

M. C. H.

The condition and the methods of mixing the colors play an important part in the art of striping and ornamental work in general. It is one thing to be able to draw accurate and uniform lines, or to execute fancy "cut up striping", scrolls, etc. and distinctly another undertaking to mix the pigments to be employed for such purposes so that the best results may be obtained. As a rule, painters meet with more or less emphasis to the small shop workmen—in using tube colors which, while being ground sufficiently fine, are very often "short" if mixed in the ordinary way. The word, "short", as applied to a striping pigment, describes a condition which causes the material, when thinned

enough to work from a palette knife, to break into drops and short, stringy bits of color. To work properly for a striping color, the pigment should flow, when thinned sufficiently, in a smooth, unbroken stream from the palette knife. When it works thus freely and smoothly from the knife or paddy you may be sure that it will work equally smooth and uniform from the point of the striping pencil. Such colors may be manipulated as follows to correct the "short" propensity:— From the tube squeeze sufficient pigment to stripe the job in hand. If ground in japan, as most tube colors may be obtained at the present time, add a few drops of finishing varnish, and a dash of turpentine to liquefy the pigment to at least a stiff paste. Then take a small portion of the mixture, and with turpentine fur-

ther reduce the material until it will flow from the knife blade to show whether it works "short" or the reverse. If the pigment is ground in oil, as some kinds usually are, beat a few drops of coach japan into a small quantity of the material and then, as above advised, add a little varnish, and test for "shortness." In the case the pigment continues short add more varnish until the defect is eliminated. Varnish, and, in fact, all liquid mediums, should be added little by little until the desired condition of the mixture is obtained.

The colors which are classed as "short" working colors are flake and Chremnitz white, Florence white, (which is merely a commercial name for zinc white), ivory and other carriage blacks, yellows of the light type in which white is the predominating pigment, and some of the reds of modern origin. All the white pigments may be improved in their working quality by treating as above and by the addition of a very small quantity of drop black mixed intimately with the white. The best method of adding one pigment to another for striping purposes, in order to insure thorough incorporation of ingredients, is to lift the desired quantity of the principal pigment onto the mixing slab, and then with the palette knife rubbing the shading, or tinting pigment, as the case may be, completely and carefully into the mass, after which further liquefying mediums may be added as required.

Caution should be exercised in employing japan to hasten the drying of striping colors. Some colors, it will be understood, are natural dryers in themselves—that is to say, they possess the essential drying power which other colors possess only after the incorporation of a certain quality of japan—while other colors are notoriously non-drying. A nice balance of discrimination is required to get the right drying property without undermining the durability of the pigment.

Gold bronze has for many years been largely used as a carriage striping material for at least the medium priced carriages. Especially in the country, and among country vehicle owners and users, the gold bronze stripe, with its burnish and its real touch of elegance, remains an undisputed favorite. Mix the bronze in, say  $\frac{2}{3}$  pale drying japan and  $\frac{1}{3}$  finishing varnish and use turpentine as a pencil dipping medium. To the



THE CHOIR GATE IN ELY CATHEDRAL. THIS PICTURE ALSO SHOWS THE UNIQUE CLOCK AT THE LEFT OF THE GATE

bronze add a few drops of flake white, mixing thoroughly, to better the working property of the bronze and to prevent the laps, where a freshly filled pencil is laid upon the point of the stripe from which the empty pencil was lifted from showing. This practice will develop improved working properties, and a finer and more uniform appearance. In using gold bronze the novice or inexperienced striper will meet with what in trade language is called "verdigris problem." This may be overcome by mixing the bronze first in benzine, or even turpentine, and standing the mixture aside over night. This verdigris or "brassy" matter will wash out and float on top of the thinning fluid, from whence it may be poured off, after which mixing of the bronze may be proceeded with. Thus treated the bronze yields a fine, rich and durable metal lustre. A great difference in gold bronze powders is to be remarked, and it is today possible to obtain a real gold bronze, and not merely the shadow and substance of it. Proportionately, of course, the price will be higher with a corresponding higher quality of results can be obtained.

One particular advantage to be noted of gold bronze for ornamental purposes is its universal usefulness—its adaptability for all colors and all surfaces. Gold is never below par even upon the family carriage, and a skilfully laid stripe or ornament of gold bronze harmonizes with every and all colors, and looks every inch the distinguished material that it is. Upon some colors, as for example, light yellows, creams and many of the lighter reds, aluminum bronze, and leaf, yield immensely pleasing results. Naturally, better effects are to be had from using the leaf than from the use of the powder. Mix the aluminum bronze powder in quite the same way that we have advised mixing the gold bronze except that the aluminum need not be submerged in, or washed out with, benzine or other volatile fluid. No other material apart from the customary thinning liquids need be added to the aluminum bronze as the verdigris propensity is not present in this material. For lettering purposes, and, indeed, for all ornamental work of importance, we would urge the use of aluminum leaf. It will insure richer and more permanent effects, to say the least. Much depends, it will be granted, upon the size used for the

leaf, and the manner of applying the size. For a comparatively quick size such as the carriage painter is often compelled to use, employ a medium quick drying finishing varnish, using turpentine sparingly as a cipper for the pencil. The difficulty of thinning the varnish out much with turpentine is that the size on the edges of the stripe dry out, or have a tendency to dry out, before the center is in a condition to



HENRY HINKINS—A SMITH FOR SIXTY-NINE YEARS

receive the leaf, with a ragged edged stripe or ornament as the result. If time will permit, use three parts of fat oil, one part finish varnish and one part gold size japan, for a size that under ordinary drying conditions will hold a good leafing "tack" for at least 10 hours. Aluminum leaf, on account of its greater thickness and coarseness of texture, will not lay securely over a size to which gold leaf will permanently adhere. In other words, the size for gold leaf may be allowed, and by experts is allowed, to dry until the "tack" is scarcely perceptible, and the burnish of the leaf when laid is all the brighter for the delay in putting on the leaf. Aluminum leaf, for the reasons already stated, would not hold fast to such a size. At the same time this leaf in common with gold leaf, is very susceptible to the effect of a size too wet at the time of applying the leaf. Applied at such a time the leaf acts in the nature of a blanket, effectually stopping further drying of the size, which in turn causes the size to penetrate and work out gradually through the leaf, causing discoloration and blackening, and loss of burnish of the metal. An over thick size, or the application of too much size which amounts to the

same thing, will produce similar results. The size that develops the best possible burnish for both gold leaf and aluminum leaf, is a fine brand of fat, raw linseed oil applied without any thinning or drying medium added to it. Admittedly, a size of this kind demands fully 24 hours, and under some adverse drying conditions, 48 hours or more, to dry out to a "tack" just right to hold gold leaf. About 24 hours will suffice for aluminum leaf. If aluminum leaf must be laid, say, an hour after applying the size, use three parts finishing varnish and one part gold size japan, and draw the lines out comparatively thin with the liquid.

For a fine, cool effect on white, cream and light yellow surfaces, blue lines drawn with exceeding accuracy, are now popular and chief of all these blue line effects is the deep chrome green stripe glazed with any one of the there shades of ultramarine blue medium shade. Lines of black, or of brown made of Indian red and black, when glazed with any one of the three shades of ultramarine blue, give charming striping effects upon the colors previously mentioned. Mix the blue for glazing purposes in a pale elastic finishing varnish, thus maintaining the original purity of the color. This rule applies with equal force to the use of carmine, the lakes and, for that matter, to the use of all transparent glazing colors. For black and the ever popular green surfaces, lines of primrose yellow, Naples yellow, canary yellow, sulphur yellow, cream color, etc., glazed with No. 40 carmine, continue to be prime favorites, both in town and country.

## Henry Hinkins — Veteran Blacksmith

Sixty-nine Years a Smith — Fifty-one Years a Foreman

I was born in Holland in 1833, and will be 83 on the 2nd day of December. Before I was 14 years old my father put me in his shop to learn the trade and attend school at night during the winter months. When I was 15 I was able to shoe horses, and do other work. In 1851 the family came to America. We first landed in Buffalo, N. Y., and in the fall of the same year moved to Milwaukee, Wis. I worked in different shops, doing wagon and buggy work. In 1856 I started to work on the Milwaukee and La Crosse R. R., now part of the Chicago, Milwaukee and St. Paul system.



There I began at the foot of the ladder, first on freight, next on passenger cars and then making and dressing tools and last on locomotive work. There were only nine fires in that shop and I had worked at eight of them by that time. I worked on almost all blacksmith work on the road. In 1865 I was induced to take charge of the St. Paul and Pacific road shop by Mr. Parker, then master mechanic. I worked thirteen years for this company when the

which ordinarily took three men, I would have four. If anything to be hoisted that would perhaps require a 1/2-inch chain I would give them a 3/8 inch chain. I always had a man running the steam hammers instead of a boy, for the reason that if a boy is any good, by the time he knows how to run it, he wants a better job. In the first place a boy is dangerous in the beginning, and by having a man that is used to it, he knows how to run it and you get better results.

smith who does automobile repairing, the blacksmith who works without reading THE AMERICAN BLACKSMITH is missing his benefits.

### Standardization of Axle Spindles, Axle Boxes, Wheel Hubs and Flanges

The leading manufacturers have agreed upon practicable and scientific "standardization" of lengths for axle spindles and boxes, wheel hubs

Size A Inch	Spindle B		FRONT FLANGE								Front Casting F	Size of Spoke G		Center of Spoke in Relation to Center of Spindle H	BACK FLANGE								Rear Casting L	Overall Length M	Style of Wheel
	Half Pattern	Concord Head	The Natl. Mfg. Castings Co.		The Dayton Mfg. Iron Co.		The Erie Mfg. Iron Co.		Inside Diameter	Point		Center E	Western Practice		Eastern Practice	The Natl. Mfg. Castings Co.		The Dayton Mfg. Iron Co.		The Erie Mfg. Iron Co.		Inside Diameter at back of point K			
			Pattern	Length C	Pattern	Length G	Pattern	Length C								Pattern	Length J	Pattern	Length J	Pattern	Length J				
20	3/4"	5/16"			03-5/16 R.	3/16"			1 1/4"	3 1/2"	3/4"	3/4"	3/4"	3/4"	3/4"	03-5/16 B.	2 1/2"			2 1/4"	None	6 1/2"	PF		
22	3/4"	5/16"	01-6/16 R.	3 1/2"	01-6/16 R.	3 1/2"			2"	3 1/2"	3/4"	3/4"	3/4"	3/4"	01-7/16 B.	2 1/2"	01-6/16 B.	2 1/2"	01-7/16 B.	2 1/2"	None	7 1/2"	PF		
0	3/4"	5/16"	0-6/16 R.	3 1/2"	0-6/16 R.	3 1/2"	0-6/16 R.	3 1/2"	2 1/2"	3 1/2"	3/4"	3/4"	3/4"	3/4"	0-6/16 B.	2 1/2"	0-6/16 B.	2 1/2"	0-6/16 B.	2 1/2"	None	7 1/2"	PF		
1	1 1/8"	5/16"	1-6/16 R.	3 1/2"	1-6/16 R.	3 1/2"	1-6/16 R.	3 1/2"	2 1/2"	3 1/2"	3/4"	3/4"	3/4"	3/4"	1-6/16 B.	2 1/2"	1-6/16 B.	2 1/2"	1-6/16 B.	2 1/2"	None	7 1/2"	PF		
3	1 1/8"	5/16"	3-6/16 R.	3 1/2"	3-6/16 R.	3 1/2"	3-6/16 R.	3 1/2"	2 1/2"	3 1/2"	3/4"	3/4"	3/4"	3/4"	3-6/16 B.	2 1/2"	3-6/16 B.	2 1/2"	3-6/16 B.	2 1/2"	None	7 1/2"	PF		
7	1 1/2"	5/16"	7-6/16 R.	3 1/2"	7-6/16 R.	3 1/2"	7-6/16 R.	3 1/2"	2 1/2"	3 1/2"	3/4"	3/4"	3/4"	3/4"	7-6/16 B.	2 1/2"	7-6/16 B.	2 1/2"	7-6/16 B.	2 1/2"	None	7 1/2"	PF		
9	1 3/4"	5/16"	9-6/16 R.	3 1/2"	9-6/16 R.	3 1/2"	9-6/16 R.	3 1/2"	2 1/2"	3 1/2"	3/4"	3/4"	3/4"	3/4"	9-6/16 B.	2 1/2"	9-6/16 B.	2 1/2"	9-6/16 B.	2 1/2"	None	7 1/2"	PF		
11	1 3/4"	7/8"	11-7/16 R.	4 1/2"	11-7/16 R.	4 1/2"	11-7/16 R.	4 1/2"	2 1/2"	3 1/2"	3/4"	3/4"	3/4"	3/4"	11-7/16 B.	2 1/2"	11-7/16 B.	2 1/2"	11-7/16 B.	2 1/2"	None	8 1/2"	PF		
13	1 3/4"	7/8"	13-7/16 R.	4 1/2"	13-7/16 R.	4 1/2"	13-7/16 R.	4 1/2"	2 1/2"	3 1/2"	3/4"	3/4"	3/4"	3/4"	13-7/16 B.	2 1/2"	13-7/16 B.	2 1/2"	13-7/16 B.	2 1/2"	None	8 1/2"	PF		
17	1 3/4"	7/8"	17-7/16 R.	4 1/2"	17-7/16 R.	4 1/2"	17-7/16 R.	4 1/2"	2 1/2"	3 1/2"	3/4"	3/4"	3/4"	3/4"	17-7/16 B.	2 1/2"	17-7/16 B.	2 1/2"	17-7/16 B.	2 1/2"	None	8 1/2"	PF		
21	1 3/4"	7/8"	21-7/16 R.	4 1/2"	21-7/16 R.	4 1/2"	21-7/16 R.	4 1/2"	2 1/2"	3 1/2"	3/4"	3/4"	3/4"	3/4"	21-7/16 B.	2 1/2"	21-7/16 B.	2 1/2"	21-7/16 B.	2 1/2"	None	8 1/2"	PF		
25	1 3/4"	1"	25-7/16 R.	4 1/2"	25-7/16 R.	4 1/2"	25-7/16 R.	4 1/2"	2 1/2"	3 1/2"	3/4"	3/4"	3/4"	3/4"	25-7/16 B.	2 1/2"	25-7/16 B.	2 1/2"	25-7/16 B.	2 1/2"	None	8 1/2"	PF		
29	1 3/4"	1"	29-7/16 R.	4 1/2"	29-7/16 R.	4 1/2"	29-7/16 R.	4 1/2"	2 1/2"	3 1/2"	3/4"	3/4"	3/4"	3/4"	29-7/16 B.	2 1/2"	29-7/16 B.	2 1/2"	29-7/16 B.	2 1/2"	None	8 1/2"	PF		
33	1 3/4"	1"	33-7/16 R.	4 1/2"	33-7/16 R.	4 1/2"	33-7/16 R.	4 1/2"	2 1/2"	3 1/2"	3/4"	3/4"	3/4"	3/4"	33-7/16 B.	2 1/2"	33-7/16 B.	2 1/2"	33-7/16 B.	2 1/2"	None	8 1/2"	PF		
37	1 3/4"	1"	37-7/16 R.	4 1/2"	37-7/16 R.	4 1/2"	37-7/16 R.	4 1/2"	2 1/2"	3 1/2"	3/4"	3/4"	3/4"	3/4"	37-7/16 B.	2 1/2"	37-7/16 B.	2 1/2"	37-7/16 B.	2 1/2"	None	8 1/2"	PF		
41	1 3/4"	1"	41-7/16 R.	4 1/2"	41-7/16 R.	4 1/2"	41-7/16 R.	4 1/2"	2 1/2"	3 1/2"	3/4"	3/4"	3/4"	3/4"	41-7/16 B.	2 1/2"	41-7/16 B.	2 1/2"	41-7/16 B.	2 1/2"	None	8 1/2"	PF		
45	1 3/4"	1"	45-7/16 R.	4 1/2"	45-7/16 R.	4 1/2"	45-7/16 R.	4 1/2"	2 1/2"	3 1/2"	3/4"	3/4"	3/4"	3/4"	45-7/16 B.	2 1/2"	45-7/16 B.	2 1/2"	45-7/16 B.	2 1/2"	None	8 1/2"	PF		
49	1 3/4"	1"	49-7/16 R.	4 1/2"	49-7/16 R.	4 1/2"	49-7/16 R.	4 1/2"	2 1/2"	3 1/2"	3/4"	3/4"	3/4"	3/4"	49-7/16 B.	2 1/2"	49-7/16 B.	2 1/2"	49-7/16 B.	2 1/2"	None	8 1/2"	PF		
53	1 3/4"	1"	53-7/16 R.	4 1/2"	53-7/16 R.	4 1/2"	53-7/16 R.	4 1/2"	2 1/2"	3 1/2"	3/4"	3/4"	3/4"	3/4"	53-7/16 B.	2 1/2"	53-7/16 B.	2 1/2"	53-7/16 B.	2 1/2"	None	8 1/2"	PF		
57	1 3/4"	1"	57-7/16 R.	4 1/2"	57-7/16 R.	4 1/2"	57-7/16 R.	4 1/2"	2 1/2"	3 1/2"	3/4"	3/4"	3/4"	3/4"	57-7/16 B.	2 1/2"	57-7/16 B.	2 1/2"	57-7/16 B.	2 1/2"	None	8 1/2"	PF		
61	1 3/4"	1"	61-7/16 R.	4 1/2"	61-7/16 R.	4 1/2"	61-7/16 R.	4 1/2"	2 1/2"	3 1/2"	3/4"	3/4"	3/4"	3/4"	61-7/16 B.	2 1/2"	61-7/16 B.	2 1/2"	61-7/16 B.	2 1/2"	None	8 1/2"	PF		
65	1 3/4"	1"	65-7/16 R.	4 1/2"	65-7/16 R.	4 1/2"	65-7/16 R.	4 1/2"	2 1/2"	3 1/2"	3/4"	3/4"	3/4"	3/4"	65-7/16 B.	2 1/2"	65-7/16 B.	2 1/2"	65-7/16 B.	2 1/2"	None	8 1/2"	PF		
69	1 3/4"	1"	69-7/16 R.	4 1/2"	69-7/16 R.	4 1/2"	69-7/16 R.	4 1/2"	2 1/2"	3 1/2"	3/4"	3/4"	3/4"	3/4"	69-7/16 B.	2 1/2"	69-7/16 B.	2 1/2"	69-7/16 B.	2 1/2"	None	8 1/2"	PF		
73	1 3/4"	1"	73-7/16 R.	4 1/2"	73-7/16 R.	4 1/2"	73-7/16 R.	4 1/2"	2 1/2"	3 1/2"	3/4"	3/4"	3/4"	3/4"	73-7/16 B.	2 1/2"	73-7/16 B.	2 1/2"	73-7/16 B.	2 1/2"	None	8 1/2"	PF		
77	1 3/4"	1"	77-7/16 R.	4 1/2"	77-7/16 R.	4 1/2"	77-7/16 R.	4 1/2"	2 1/2"	3 1/2"	3/4"	3/4"	3/4"	3/4"	77-7/16 B.	2 1/2"	77-7/16 B.	2 1/2"	77-7/16 B.	2 1/2"	None	8 1/2"	PF		
81	1 3/4"	1"	81-7/16 R.	4 1/2"	81-7/16 R.	4 1/2"	81-7/16 R.	4 1/2"	2 1/2"	3 1/2"	3/4"	3/4"	3/4"	3/4"	81-7/16 B.	2 1/2"	81-7/16 B.	2 1/2"	81-7/16 B.	2 1/2"	None	8 1/2"	PF		
85	1 3/4"	1"	85-7/16 R.	4 1/2"	85-7/16 R.	4 1/2"	85-7/16 R.	4 1/2"	2 1/2"	3 1/2"	3/4"	3/4"	3/4"	3/4"	85-7/16 B.	2 1/2"	85-7/16 B.	2 1/2"	85-7/16 B.	2 1/2"	None	8 1/2"	PF		
89	1 3/4"	1"	89-7/16 R.	4 1/2"	89-7/16 R.	4 1/2"	89-7/16 R.	4 1/2"	2 1/2"	3 1/2"	3/4"	3/4"	3/4"	3/4"	89-7/16 B.	2 1/2"	89-7/16 B.	2 1/2"	89-7/16 B.	2 1/2"	None	8 1/2"	PF		
93	1 3/4"	1"	93-7/16 R.	4 1/2"	93-7/16 R.	4 1/2"	93-7/16 R.	4 1/2"	2 1/2"	3 1/2"	3/4"	3/4"	3/4"	3/4"	93-7/16 B.	2 1/2"	93-7/16 B.	2 1/2"	93-7/16 B.	2 1/2"	None	8 1/2"	PF		
97	1 3/4"	1"	97-7/16 R.	4 1/2"	97-7/16 R.	4 1/2"	97-7/16 R.	4 1/2"	2 1/2"	3 1/2"	3/4"	3/4"	3/4"	3/4"	97-7/16 B.	2 1/2"	97-7/16 B.	2 1/2"	97-7/16 B.	2 1/2"	None	8 1/2"	PF		
101	1 3/4"	1"	101-7/16 R.	4 1/2"	101-7/16 R.	4 1/2"	101-7/16 R.	4 1/2"	2 1/2"	3 1/2"	3/4"	3/4"	3/4"	3/4"	101-7/16 B.	2 1/2"	101-7/16 B.	2 1/2"	101-7/16 B.	2 1/2"	None	8 1/2"	PF		

**NOTES**

- The Axle, Flange and Wheel shown herein are to be regarded as "Standard" and the short will be known as "Standard Specification". The "Standard" Axle, Flange and Wheel are expected to be carried in stock or made up promptly after receipt of order.
- All Axle Sizes and all Flange and Wheel sizes are to be known as "Odd Sizes", and all Axles or Wheels requiring "Odd Size" parts are to be regarded as "Special". "Odd Size" in Axle, Flange and Wheel are not to be carried in stock and will be made up subject to extra cost and delay.
- All Axles in 1 1/2 inch sizes are to be discontinued, except the H" and 1 1/2".
- Where two lengths of Spindles are shown for any one size axle, it is intended that both shall be "Standard". Intermediate sizes or longer and shorter sizes will not be "Standard".
- No Half Pattern boxes to be made in 1 1/2" or larger sizes.
- All wheel hubs, compressed band and shell band wheels must conform to lengths given herein.
- Eight-hole Flange and 12-spoke Wheels only are furnished in all sizes, except that 8-hole Flange and 12 Spokes may be ordered in sizes No. 39 and larger.
- No. 03 Flange with 1/2" Axle, 3/4" Spindle, 5/16" Spindle are recommended for Pump Vehicles only.
- Order Flange by pattern number, giving the number of pieces and length of Front and Back Flange.
- In ordering Wheels, give size of Spoke and size and type of Axle with Spindle Length as shown above.
- These "Standard Specifications" become effective at once, but it is not expected that there will be any advance in price on "Odd Sizes" until January 1, 1917. The interval should permit of evening up and disposing of all present stocks of "Odd Size" material.

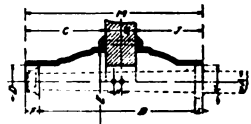

**STANDARD SPECIFICATIONS FOR AXLE SIZES, SPINDLE, BOX, AND HUB LENGTHS AND FLANGE SIZES ADOPTED BY VEHICLE INTERESTS**

road went into the hands of the St. Paul and Manitoba. Later it went under the name of the Great Northern in the control of J. J. Hill. During all my fifty-one years I have worked under 14 different shop superintendents and all of them except one, has treated me like a gentleman. During all those years I have had only one man in the hospital. This man lost one eye by missing the iron and his hammer striking the edge of the anvil, and a piece of the hammer struck the eye. I have always made it a rule when any heavy piece was to be moved

I have been married 60 years, last April, and have five children, (one son and four daughters), nine grandchildren and one greatgrand child. We celebrated our sixty years the 20th of last April and all were happy. All of our children live within 400 feet of our home. I have been a reader of THE AMERICAN BLACKSMITH almost from the beginning and have found many valuable suggestions and hints from the many different blacksmiths. One month's issue pays for many months for any horse-shoer or wagon, buggy or general blacksmithing, or any

and flanges, and the accompanying table shows the result. The spindle lengths, flange sizes and hub sizes shown are to be known as "standard sizes" and are the only ones which are hereafter to be carried in stock. All other spindle lengths, flange and hub sizes will be considered as "odd sizes" and are not expected to be carried in stock, but will have to be made up after receipt of orders. As the shortage of material which now distresses the vehicle trade can be relieved only by immediate general approval of the "standard



specifications," and as the axle, wheel, malleable iron, buggy and wagon trades have all participated in this effort, giving it their sanction and approval, the committee hopes all will extend their active support in establishing the "standards" on a permanent basis.

### Nowlan's Aeronautical Ship

Editor's Note—The following article and its accompanying engraving appeared in the April (1856) issue of the "Coach-Makers Illustrated Monthly Magazine."

The figure of this aeronautical ship is a parallelogram, 360 feet long, 26 feet wide, and 36 feet deep, formed of sheet copper framed with tubes to give strength and lightness. It is capable of carrying 1,000 tons

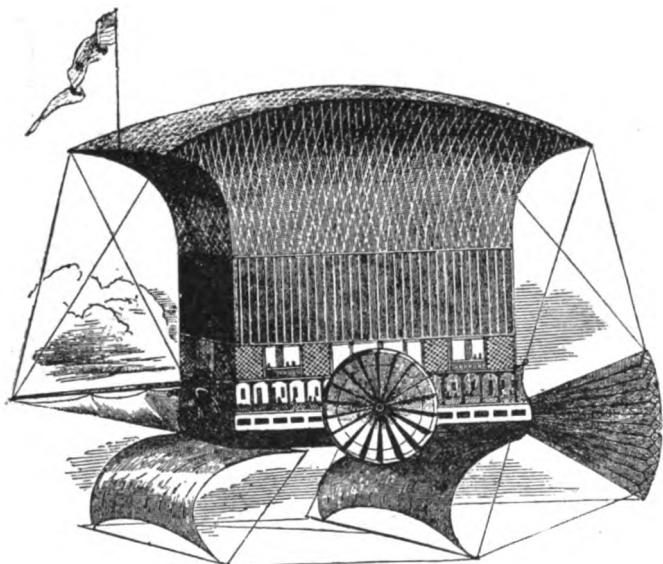

NOWLAN'S AERONAUTICAL SHIP AS ANNOUNCED IN A COACH BUILDERS MAGAZINE IN 1856

burden. The promenade or upper deck reaches from end to end, and is tastefully arranged for the comfort of passengers. The second deck is arranged for the grand saloon and private sleeping rooms for first class passengers. The third deck is for steerage passengers and luggage, and contains the engine room and storage for the cargo. Underneath all is a gun-wale running round, 6 feet wide and 10 feet deep, between the sides of which is an open space of 14 feet, through which the sails are worked. Ascent or descent is effected by a circular movement performed by means of the helm and paddle-wheels, which have a power of ascending in a spiral form as the tubes are inflated by the engine, and descending similarly as the gas is contracted by the same running from end to end, are conmeans. The vertical gas wrappers,

finied by light net-work, 25 feet high, and 360 feet long. They stand 18 feet above the upper deck and communicate with the gas pipes by tubes. The engine of 16 horse power is worked by a galvanic battery. The sails, eight in number, are suspended from the bottom of the lower deck, and are worked from it.

With this arrangement, the circuit of the globe can be made in 24 hours! incredible as it may seem to those who do not reflect that the earth revolves in its diurnal course in that space of time, and that at a certain height above the earth's surface the atmosphere is fixed and stationary. To reach any given point, therefore, it is only necessary to elevate this ship to that height,

and after propelling it by means of wheels, sails and helm, to the latitude of the place required, wait for it to move to the ship's position, and descend to it as the skylark descends from his high attitude to his nest and his mate below.

The dangers and calamities that almost daily occur in the ordinary means of traveling by sea and land would thus be avoided, and the awful sacrifice of life and property attending them be done away with.

The necessity for more speedy, safe and economical modes of transportation of persons and property is acknowledged by all, and the inventor of this arrangement feels assured that his device will be found to answer all these requirements more perfectly than any previous one, and will effect all he claims for it.

### Don't Place Fire Insurance With Anybody You Don't Know About

Several months ago, in the course of an article on one phase of insurance, I said that a man who placed fire insurance with anybody but the home office, or an accredited general agent or branch manager, should al-

ways see to it that the solicitor had authority to accept the business, and that he actually forwarded this particular business and had it accepted by the company. Otherwise the company might avoid paying the loss if there was a fire. The situation which I contemplated was the precise situation reported in the following letter:

Springfield, Ohio.

A few weeks ago I placed some fire insurance on shop building and warehouse with a young chap who had been acting as solicitor for a Pennsylvania company. I was anxious to help him along, so I gave him the insurance instead of to a local agent, who represented other companies, and who had handled most of my insurance for several years. A few days after I gave the order and paid the premium to this young fellow, he came in and said the insurance was in force and he would send me the policy as soon as it arrived. I never got the policy; in fact, I was absent from business after that and it slipped my mind. We had a fire last month, loss \$1,300, and the company says the order was never received by them and they therefore are not liable. Was not the solicitor an agent of the company, and when I gave him the order—at his own solicitation—and paid him the premium, was it not the same as if I had done it to the company itself? Would you not advise me that the company was bound in this case?  
R. M. & Co.

I am much inclined to believe that the company is not bound and that this correspondent must stand the loss himself. Of course he can either arrest the solicitor, or he can sue him for damages for misrepresentation, but both of these remedies are quite unsatisfactory compared with collecting the fire loss.

When insurance is placed direct with the home office of an insurance company, of course, the company is bound from the minute it accepts the order. And when insurance is placed with a general agent located in some outside town or city, the company is bound in the same way, because the general agent of an insurance company always has authority to solicit and accept business, and to bind the company *when* he accepts it.

But when you place business with a solicitor—even a solicitor of the home office or of the general agency in your town—you are taking a risk, because a solicitor's authority is usually limited to soliciting applications and submitting them to his superiors, who can reject them if they like. When an application is submitted to a superior and accepted, then the company is bound and not before. Until then, the matter is open. If the solicitor puts the premium in his pocket and the



application in his desk, of course, the company is not bound, because it never got into the matter at all. That seems to have been the case here.

As a recent Western case, where the facts were somewhat similar (National Union Fire Insurance Co. vs. School District, 182 S. W. 547, Arkansas Supreme Court) puts it:—

*There was no contract of insurance here, because the agent had only the power to receive and forward applications, and the company could always refuse or accept an application at its discretion. One who gives business to a soliciting agent is bound to know the extent of the agent's power, he cannot assume that the agent has unlimited power.*

I have repeatedly said that more carelessness is exhibited by business men toward their insurance matters than toward anything else. This case is exactly in point, in these respects:—

1—This correspondent evidently made it easy for the solicitor to steal the premium by making the check out to his order or paying him in cash. I assume this, but of course I may be wrong. Checks for insurance premiums should always be made out to the company or to the accredited general agent, *never* to a solicitor.

2—This correspondent went away and forgot to get his policy. Had he kept after it and demanded it, the fraud would have been discovered and he could have protected himself before the fire.

The same pressing need to know that an insurance agent with whom you are dealing has authority to bind the company extends to other matters than accepting business. It extends to such matters as changing the terms of a policy or granting concessions and extensions, which things are done thousands of times every day. An agent may not have power to do these things, though he may have power to do everything else. When such things are asked of an agent it is the duty of the person asking to know that the agent has authority to do it. He should not rest until he has the company's O. K. It is all right for the agent, when you ask him, to say, "Oh, certainly, I have authority to do that. I do it a dozen times every day." That will not help you if something arises and the company refuses to be bound on the ground that the agent lacked authority to bind in this respect. Hundreds of

policies have been made invalid in exactly this way.

If you deal with anybody but the home office in such matters, you are not safe until you have the company's written O. K.

(Copyright by Elton J. Buckley.)

## The Smith in The Daily News

Odd Mention of Anvil Ringers and Knight of the Forge in the News of the Day.

### Blacksmith Appointed Sergeant.

Because of his skill at handling Uncle Sam's cavalry horses on the Mexican border, Emerson Fenton, of Banksville, Pennsylvania, has been appointed foreman of the camp's smithy and awarded the chevrons of a sergeant.

Sergt. Fenton and his brother, George Fenton, conducted a blacksmith shop at Banksville. George is keeping the shop until the sergeant returns.

Mr. Fenton enlisted in Company D, Eighteenth Regiment, more than a year ago. Shortly after his arrival at the border the need of horseshoers was discovered. Private Fenton and several others were selected. Officers inspecting the work of the blacksmiths saw an unusual knack at handling the horses in Mr. Fenton and he was made foreman of the shop.

Sergt. Fenton is pitcher in Company D's baseball team, and will play in the company's football team. He is aged 21 years and is a son of Mr. and Mrs. Matthew J. Fenton, of Banksville. He is the town's only representative in the Mexican border expedition.

### Blacksmith Boxing Champion.

"Les Darcy is a great man as fighters of the day run," says Buck Crouse, of Pittsburgh, upon his return from Australia. And Buck ought to know, for Darcy and Buck had a regulation bout over in the "Island Empire" which Darcy won easily. But to resume the story of this blacksmith. Mr. Buck Crouse says:

"To start with, Darcy has got a pair of hands that are like a couple of sandbags that the holdup men use. One clout with either one of them and it's all off with you. His right is particularly good. He gets in close and clips you in the ribs with it. He hits short and very effectively.

"His training as a blacksmith has given him these hands and a pair of forearms that are wonderful. His leg is very good as well, and as he does not give you any time to set yourself for a punch, he usually has the advantage right from the start. He has a knack of keeping a man going backwards all the time."

### Bends Steel Bars Like Wire.

John H. Thompson, a Portland blacksmith, and a man of massive strength escaped from the state insane asylum. As if they were made of wire, he twisted apart the steel bars of a window with

his hands. W. A. McKay, another asylum inmate, also escaped through the window.

### Blacksmith Has Toe Broken.

Henry Roembke, a blacksmith in the Pennsylvania erecting shops, was disabled when fifty pounds of steel fell upon his left foot, breaking the large toe. An X-ray examination was made to determine the extent of Mr. Roembke's injuries. He will doubtless be laid up for several weeks as a result of the accident.

### Horse Kicks Blacksmith to Death.

John J. Bate, of Butte, Montana, was putting shoes on a horse when the animal kicked him in the breast, knocking him a distance of four or five feet.

When Frank J. Stanaway took Bate to his home the blacksmith complained of pains in his chest. Shortly afterward Bate died, due to shock caused by the kick. The undertaker testified that no marks or bruises were found on the body.

### Blacksmith May Lose Hand.

Martin Spiegel, a blacksmith, of Paris, Kentucky, while at work in his shop, stuck a nail in his hand. He tied the injured member with a rag which he soaked in turpentine. Returning to his work at the forge he allowed his injured hand to come into contact with the fire. The turpentine ignited and before help could reach him his right hand was so badly burned that it is thought it will have to be amputated. His left hand was badly burned in his efforts to tear away the burning rag.

### Blacksmith Injured by Man He Befriended.

Fred H. Berger, a blacksmith of South Woodstock, was attacked by Peter Sautler, who, armed with a knife, tried to kill his blacksmith benefactor.

Sautler appeared in Woodstock the first of the summer, down and out, and Berger took him in. Recently Sautler had been acting queerly and one morning began throwing things around his roof. When Berger told him to stop Sautler took out a large pocketknife and slashed Berger. A scuffle followed, and Mrs. Berger ran to her husband's assistance. They were unable to disarm Sautler.

Berger's 12-years-old boy, Arthur, went to the blacksmith shop and, getting a pair of tongs, grabbed Sautler's wrists with them and squeezed them until he dropped the knife. Sautler was then overpowered. He was arrested and taken before Justice Charles L. Perrin on a charge of assault with intent to kill.

### Frank Eachus, Horseshoe Pitching Champion.

Frank Eachus, of Gallipolis, Ohio, is the horseshoe pitching champion of Ohio. In a recent tournament he won every one of his games against various opponents and ended by winning four straight from Joe Brickar, of Canton, who took second honors. Eachus, the champion, took a prize of one hundred dollars in gold, and a diamond-studded gold medal. His games were pitched before crowds of from 2,000 to 3,000, who cheered as though they were seeing a game of baseball. On the final day when he won the championship, Eachus, in seven games, made 23 "ringers" besides those he lost by being "topped" by his opponent.





## A Wise Guy

W. O. B.

There was a Young Upstart folks said had no sense, who started in business on ninety-eight cents. The ninety he paid on some stock and a forge and the eight he just squandered on hand bills, by George. The dodgers were out but an hour or so, when into the shop came five bones in a row. He stuck three of these into more tools and stock, one went into ad-space and the fifth in his sock. The ad-space invited more folks to his place, while the money they brought put a smile on his face.

Soon people were flocking to his four-by-eight dump, and for a new work shop he soon had to hump. Then down on the square where the people all pass he bought up a corner—Young Upstart had class. He built there a shop that beat others a mile—'twas concrete and brick and of artistic style. The machinery and tools and equipment were "right" and folks who have seen 'em say: "Cost quite a might." And when all was ready a great big page ad told of his shop and the equipment he had.

And while things were coming, he'd most reached the top, he never quit advertising his shop. Folks often would tell him he'd save quite a bit, if he'd cut his ads down, but he said: "Not a Jit." And so he kept moving along at a pace that left his competitors out of the race. He's now the Napoleon of Hamiltonville where all wish him well and none of 'em ill.

Some call such stuff luck, but that is all bunk—for didn't he prosper when times were just punk? The secret is this, let me put you wise—the way to get business is to advertise.



## Heats, Sparks, Welds

Take care of the pennies and the minutes and—success will stare you in the face.

If some horseshoers pared expenses the way they do hoofs, they wouldn't have any bills to pay.

No matter how much, put something aside for a rainy day, it will surprise you how soon a little means a lot.

He is a poor smith and a poor business man, indeed, who allows himself to be stumped by the same job twice.

You may be sure that a man is very

busy when he has been so busy that he has had no time to tell folks how busy he has been.

Every job you do must pay its proportion of light, rent, heat and etc. Are you feeding the profits of one job to keep other jobs alive?

You deserve all the business you can get, whether it wanders in, or is coaxed in, or whether you have to go out and bring it in by force.

What do you pay yourself as proprietor? You should receive a salary and you are worth more than anyone of your men, see that you get more.

Make a place for yourself on the Honor Roll. A ten-year subscription will save you half your subscription money and place your name among the leaders right now.

A business smith may fool himself by failing to charge all of his expenses into his cost of doing business, but his expenses will come out of his gross profit just the same.

When the chap with the winsome smile, the steady eye and the persuasive tongue calls on you, listen if you want to and accept his cigar also, but do please keep a tight hold on your wallet.

Funny, isn't it! that when there are leaks in the roof, there are usually leaks in the business. Some folks try stopping both leaks by covering the shop with a mortgage, but it's poor business.

Don't wait until a new competitor prods you into life. Make such a hot fight for business every minute, that the new competitor will stay away. Keeping everlastingly at it will prevent him from even getting located.

Some smiths seem to think that to fold their arms and lean against the front door sill "kind of graceful-like," will draw trade as a magnet does steel. Other smiths just keep a-hammering and a-hustling while they are waiting.

The best time to adjust credit matters is before you deliver the goods. Then if things don't suit you, you can withdraw. Better have the material in the shop and the labor undone, than in a dishonest customer's hands and not paid for.

A good time to fix up the shop roof is before the snow flies. Perhaps a few shingles are all the roof needs. Then again, it is sometimes cheaper to apply a layer of new roofing. Some of the patent roof coverings are cheap, good and easily applied.

Try your telephone as a collector. After you have sent your customer a bill and have asked him to remit, if he doesn't pay any attention to your notices by mail, just ring him up on the 'phone as a reminder. The chances are this will bring him to time.

How long is it since you have contributed to these pages? Let the Editor hear from you occasionally. Surely, you know of methods, hints, kinks and recipes not generally known to the craft at large. It won't take you a minute to send in something of interest.

Sometimes it is more economical to spend money than to put it in the bank. Economy is not so much the saving of money, as it is the saving of what you buy with the money you spend. Many smiths would save money if they purchased new shop equipment.

Have you applied that coat of white-wash to the interior of the shop walls? The doors and windows will be closed

pretty much from now on, and bright white walls will help materially to make the interior of the shop more cheerful during the closed door season.

Those who never hear of you or your shop, can never trade with you. Only by adding new customers, can your business increase, and you can only add new customers by advertising in one way or another. Advertising will carry your shop sign right to the people you want as customers.

Safety devices pay from every viewpoint. The worker who must keep one eye on his machine to keep from losing a finger or an arm, cannot turn out as much nor as good work as the chap who can devote all of his attention to his work, and knows that with reasonable care his fingers are safe.

"Strike while the iron is hot" is an old saying, but is an excellent one to apply in the case of collections. When you hear of a farmer customer selling a lot of his produce—present your bill immediately, get after him quick and before he has a chance to put the money away where you cannot get at it.

Welding is just about the most exacting operation in any smith's work. There are no half measures in welding—either it is or it isn't a good job. No amount of argument, no amount of demonstration, no amount of testing will make it anything, but what it really is, and when a welding job is poor, it is absolutely no good.

Clean up the old accounts—go after them tactfully, persistently and thoroughly. If necessary, sue for your money, and then start with a clean slate, and keep it as clean as you can. You cannot run your business on the money in your debtor's pocket, and your efforts and work will not do you or your family, or your business any good, unless you get the money that belongs to you.

A heavy purse makes a light heart. A man who has practiced a quick saving plan says: "I got into the habit of forcing myself to yield a surplus every month. When I had saved a few hundred dollars, I looked for a good investment—real estate in a good place at a good price. I then improved it, borrowed the money, if necessary, and rented as quickly as possible, I looked for a purchaser at a profit. I have saved and I am ready for the rainy day."

When you share your experiences, your knowledge and give advice you are building up the future of the craft—you are helping future smiths. How much progress do you suppose would be made in the craft, if each smith kept all of his experience to himself? If when he discovered a new kink, method or short cut, he guarded it like a family secret? Just suppose all smiths had done this since the time of Tubal-Cain—how much would the average smith of today know?

Straight from the shoulder, let your slow paying customers have it. The next time the slow payer does not come to time when he promised, try an argument along this line: "Mr. Brown, you promised to pay this bill today. My credit depends upon my being able to pay my bills promptly. I cannot do this unless my customers settle with me as they agree. If you haven't the money, there are banks in town for the very purpose of accommodating men in your situation—but I am not in the banking business."



# Our Honor Roll

### AND STILL THEY COME

More and more readers are taking advantage of "Our Honor Roll" every month and it is becoming more difficult each month to find a place on the list of Honor Subscribers. If you do not know what a saving you can make by taking advantage of Our Long-Time Rates look over the table of rates and see just how you can save money and at the same time insure your subscription account. Sharpen your pencil and get down to actual figures and then get your name on this list of Readers who are paid up well in advance.

U. S. and Mexico		Canada		Other Countries.	
2 yrs.....	\$1.60 save \$ .40.....	\$2.00 save \$ .50.....	10 sh. save 2 sh.		
3 yrs.....	2.00 save 1.00.....	2.70 save 1.05.....	14 sh. save 4 sh.		
4 yrs.....	2.50 save 1.50.....	3.20 save 1.80.....	18 sh. save 6 sh.		
5 yrs.....	3.00 save 2.00.....	3.75 save 2.50.....	1 £ save 10 sh.		
10 yrs.....	5.00 save 5.00.....	7.00 save 5.50.....	1£ 14 sh. save 1£ 6 sh.		

Send your order and remittance now—today. Don't wait until you forget all about it. You'll never regret it. Our subscription insurance saves you money. The sooner you begin saving the more you save. There is no better time than NOW.

NAME	Subscription Paid to	NAME	Subscription Paid to
The Fix-It Shop, Utah.....	July, 1935	I. L. Fenton, New Mexico.....	May, 1924
J. A. Torray, Mass.....	Dec, 1933	J. Carl, Iowa.....	May, 1924
W. C. Watt, Kansas.....	Dec, 1930	J. E. Little, Pa.....	May, 1924
L. J. Stites, N. Y.....	Jan, 1929	H. I. Brenzle, N. Y.....	Apr, 1924
Waddington Farm, W. Va.....	Mar, 1928	W. E. Parr, Iowa.....	Apr, 1924
A. A. MacLean, Nev.....	Feb, 1927	F. Sramek, Nebr.....	Apr, 1924
C. M. Adams, Conn.....	Jan, 1927	L. A. Hulien, Calif.....	Apr, 1924
Platinum Shoeing Shop, Colo.....	Dec, 1926	J. E. Ray, Minn.....	Mar, 1924
John H. W. Schneider, Cal.....	Dec, 1926	A. Hulstrand, N. D.....	Mar, 1924
J. Taylor, Calif.....	Oct, 1926	W. F. Riske, Wisc.....	Mar, 1924
J. A. Buchner, Mich.....	July 1926	E. F. Seibert, Calif.....	Mar, 1924
H. Mitchell, N. Y.....	July 1926	H. Roeschwetter, Mo.....	Mar, 1924
M. Eron, N. D.....	June 1926	W. B. Briant, N. J.....	Mar, 1924
A. Schmitt, Nebr.....	June, 1926	A. Bosch, N. Y.....	Mar, 1924
D. Ackland & Son, Man.....	May 1926	D. Van Valkenburg, Mass.....	Feb, 1924
H. Fhrst, Ore.....	May 1926	A. R. Johnson, K. I.....	Feb, 1924
J. Snelcar, W. Australia.....	May, 1926	F. Jacobs, Ohio.....	Feb, 1924
F. Sova, Oregon.....	May, 1926	A. J. Ferry, Illinois.....	Jan, 1924
E. P. Dugman, S. Australia.....	Apr, 1926	E. G. Walker, Calif.....	Jan, 1924
P. A. Peterson, Iowa.....	Apr, 1926	H. D. Erskine, Vermont.....	Jan, 1924
G. F. Bowers, Oha.....	Apr, 1926	E. Fowler, Pa.....	Jan, 1924
W. Pochel, Oregon.....	Mar, 1926	Breen & Son, Ireland.....	Dec, 1923
A. Garver, Ohio.....	Feb, 1926	M. Lamoreaux, Ohio.....	Dec, 1923
C. Burton, Mass.....	Mar, 1926	C. R. Davis, N. Y.....	Dec, 1923
J. F. Murphy, Nev.....	Jan, 1926	F. W. Copeland, Kansas.....	Dec, 1923
F. Korman, Illinois.....	Jan, 1926	H. L. Tomlin, Kansas.....	Dec, 1923
J. M. McIntire, Pa.....	Jan, 1926	J. A. Davis, N. Y.....	Dec, 1923
W. Post, N. Y.....	Jan, 1926	E. H. Troyke, Illinois.....	Dec, 1923
Fowell Brothers & Whitaker, Eng-land.....	Jan, 1926	D. B. Johnson, Iowa.....	Dec, 1923
O. Temple, Idaho.....	Jan, 1926	S. Horton, Calif.....	Nov, 1923
N. Karolewicz, S. Dak.....	Jan, 1926	J. Spratt, Mass.....	Nov, 1923
E. L. Lain, N. Y.....	Dec, 1925	F. Watkins, N. H.....	Nov, 1923
J. A. Hulvey, Illinois.....	Dec, 1925	F. Koppins, Ala.....	Nov, 1923
Williams & Turner, W. Va.....	Dec, 1925	Y. C. Lienert, S. Australia.....	Oct, 1923
J. J. Devine, N. J.....	Dec, 1925	W. B. Abell, N. Y.....	Oct, 1923
P. Nelson, Minn.....	Dec, 1925	W. R. Turner, Man.....	Oct, 1923
M. Kennedy, Tas. Australia.....	Dec, 1925	C. Nelson, Nebr.....	Sept, 1923
A. J. Wassmuth, Idaho.....	Dec, 1925	H. M. Anderfuren, Calif.....	Aug, 1923
J. G. H. Mallett, Queens, Australia.....	Nov, 1925	Camp Brothers, Texas.....	Aug, 1923
A. W. Speir, Ohio.....	Nov, 1925	L. C. Larson, Iowa.....	July, 1923
W. R. Clepper, Texas.....	Nov, 1925	S. Effenaar, South Africa.....	July, 1923
G. H. Isley, Mass.....	Nov, 1925	G. L. DeWitt, Mont.....	July, 1923
Reynolds Brothers, Pa.....	Sept, 1925	W. W. Gregg, Texas.....	July, 1923
F. W. Krenz, Calif.....	Aug, 1925	W. R. Stroupe, N. C.....	July, 1923
C. E. Allen, Nebr.....	Aug, 1925	O. C. Young, Michigan.....	June, 1923
A. E. Spangberg, Oregon.....	May, 1925	Otto Sippel, Pa.....	June, 1923
D. M. Klie, Oha.....	Apr, 1925	A. Chapman, N. Y.....	June, 1923
G. Gullgren, Iowa.....	Apr, 1925	C. Birley, Md.....	June, 1923
G. Frierick, Minn.....	Mar, 1925	F. H. Stupe, Pa.....	June, 1923
V. Prissnitz, Wisc.....	Mar, 1925	J. C. Stover, Pa.....	Apr, 1923
E. Price, Illinois.....	Feb, 1925	W. Schoonover, Pa.....	Apr, 1923
D. C. Garber, Ohio.....	Feb, 1925	L. M. Rumrle, Iowa.....	May, 1923
J. H. Kirk, Illinois.....	Feb, 1925	Johnsdale Brothers, Mo.....	Mar, 1923
E. B. Hiteshew, Ohio.....	Feb, 1925	J. Carswell, Ark.....	Mar, 1923
H. F. Schreiber, Pa.....	Feb, 1925	G. E. Glazier, Ohio.....	Mar, 1923
J. S. Damm, Iowa.....	Jan, 1925	G. Fath & Co., S. Africa.....	Mar, 1923
I. M. Withers, Hawaii.....	Jan, 1925	T. Bradley, N. S. Wales.....	Mar, 1923
N. B. Quick, Pa.....	Dec, 1924	L. T. Needham, Illinois.....	Feb, 1923
W. H. Jarvis, Indiana.....	Dec, 1924	G. C. Disinger, Miss.....	Feb, 1923
George Tatum, Jr., Fla.....	Dec, 1924	J. Hughes, Ohio.....	Feb, 1923
L. Clark, Va.....	Dec, 1924	J. Weber, Minn.....	Jan, 1923
A. N. Estes, Va.....	Dec, 1924	Z. A. Enos, Minn.....	Jan, 1923
J. Bailey, Manitoba.....	Dec, 1924	W. G. Wise, Calif.....	Jan, 1923
E. G. Naylor, Md.....	Dec, 1924	F. S. Bishop, South Africa.....	Jan, 1923
Halvorson Brothers, S. D.....	Nov, 1924	J. Curran, Arizona.....	Jan, 1923
P. Schicks, Washington.....	Nov, 1924	S. P. Harney, Mont.....	Dec, 1922
H. E. Snyder, Oregon.....	Nov, 1924	W. Breckner, Oha.....	Dec, 1922
J. A. Stewart, Ky.....	Oct, 1924	J. Fabina, Nebr.....	Dec, 1922
C. Richenacker, N. Y.....	Oct, 1924	P. Frederickson, Iowa.....	Nov, 1922
W. L. Berthoff, N. J.....	Oct, 1924	L. O. Leirus, Illinois.....	Nov, 1922
J. W. Hewson, S. Africa.....	Sept, 1924	W. Lawson, New Zealand.....	Nov, 1922
Ed. Larson, N. D.....	Sept, 1924	O. O. Grant, Calif.....	Oct, 1922
R. T. Monk, Illinois.....	Sept, 1924	W. H. Miller, Iowa.....	Oct, 1922
W. T. De Young, Illinois.....	Sept, 1924	J. S. Lee, Wash.....	Sept, 1922
C. W. Taylor, Pa.....	Aug, 1924	A. O. Martin, Idaho.....	Sept, 1922
Charles Wells, Colorado.....	Aug, 1924	O. A. Mortimer, Idaho.....	Sept, 1922
H. G. Weaver, Pa.....	Aug, 1924	H. J. Hyatt, Washington.....	Sept, 1922
Working Men's College, Viet.....	June, 1924	N. K. Snow, Iowa.....	Sept, 1922
F. M. Kenoyer, Nebr.....	June, 1924	A. D. Standiford, Washington.....	Sept, 1922
S. C. Frederick, N. D.....	May, 1924	T. Temkiewicz, Quebec.....	Sept, 1922
		A. Peliffer, Ohio.....	Aug, 1922
		W. D. Valentine, Iowa.....	Aug, 1922

NAME	Subscription Paid to	NAME	Subscription Paid to
G. Hoffman, N. Y.....	July, 1922	R. L. Whitfield, N. S. W., Aust.....	Nov 1920
J. Eran, Ark.....	July, 1922	McFarlane & Pratt, S. Africa.....	Oct, 1920
W. K. W. Hansen, Pa.....	June, 1922	Thomas Scurr, New Zealand.....	Oct, 1920
Robert Tochter, Calif.....	June, 1922	W. H. Finlay, New Zealand.....	Oct, 1920
J. Van Marter, N. Y.....	June, 1922	C. L. Massey, Ark.....	Sept, 1920
F. Norris, Yukon Ty.....	Jan, 1922	J. Jordan Cal.....	Sept, 1920
E. Anders & Son, S. Australia.....	May, 1922	J. Jordan, Calif.....	Sept, 1920
Louisa Carriage Works, Va.....	May, 1922	L. O. Breke, Washington.....	Sept, 1920
S. Smith, Texas.....	Apr, 1922	R. D. Stinking, Penna.....	Sept, 1920
J. W. Haar, La.....	Mar, 1922	A. E. Revoe, Mass.....	Sept, 1920
D. W. Smith, La.....	Mar, 1922	L. E. Bouton.....	Aug, 1921
D. W. Smith, Rhode Island.....	Mar, 1922	G. W. Phillips, Utah.....	Aug, 1920
E. A. Dillon, Nev.....	Mar, 1922	T. Chittenden, New Zealand.....	July, 1920
D. F. Kuster, Washington.....	Mar, 1922	O. Smith, Pa.....	July, 1920
G. F. Johnson, Michigan.....	Feb, 1922	F. A. Poole, South Africa.....	July, 1920
R. H. Keith, Iowa.....	Jan, 1922	C. Gibson, Ill.....	July, 1920
F. H. Joelin, Mass.....	Dec, 1921	H. M. Whitman, Neb.....	July, 1920
J. B. Scheider, Indiana.....	Dec, 1921	The Goldfield Diamond Drilling Co., Victoria, Australia.....	July, 1920
J. H. Ickes, Pa.....	Dec, 1921	R. M. Robben, Kans.....	July, 1920
E. Willis, Colorado.....	Dec, 1921	G. J. J. Rees, S. Australia.....	July, 1920
J. Delane, Nebr.....	Nov, 1921	A. C. Morrell, N. B.....	June, 1920
O. M. Johnson, Miss.....	Oct, 1921	L. R. Garvin, Ohio.....	Sept, 1920
K. G. Glinicki, Mich.....	Sept, 1921	H. Fast, Man, Can.....	June, 1920
H. Feldus, Nebr.....	Sept, 1921	L. Underhill, California.....	June, 1920
R. Murray, Calif.....	Sept, 1921	F. Feltz, Ohio.....	June, 1920
A. Hammond, Calif.....	Sept, 1921	W. M. Puryear, Ala.....	June, 1920
P. Wedel, Kans.....	Sept, 1921	W. L. Patterson, Oha.....	June, 1920
A. S. Pratt, New York.....	July, 1921	D. Hardy, Viet.....	June, 1920
E. H. Spain, Ariz.....	July 1921	E. Malpas, S. Australia.....	June, 1920
J. M. Werl, Pa.....	June 1921	A. J. Hamburg, Ohio.....	June, 1920
S. Budds, New Guinea.....	May 1921	C. M. Holton, Oha.....	June, 1920
H. Baker, Aust.....	May 1921	C. L. Graf, Ohio.....	June, 1920
F. E. Smith, Vermont.....	May, 1921	A. Mellum, N. D.....	June, 1920
A. J. Hatch, Maine.....	May, 1921	J. A. Schmits, N. D.....	May, 1920
W. Cornwell, Pa.....	May, 1921	P. Wright, Calif.....	May, 1920
W. F. Kline, Kansas.....	May, 1921	F. Greer, Queens.....	Apr, 1920
J. Kirkbride, N. J.....	May, 1921	C. L. Morman, N. Y.....	Apr, 1920
T. Holloway, Kans.....	Apr, 1921	H. W. Fuhrkop, Ill.....	Apr, 1920
W. Winget, Vt.....	Apr, 1921	A. Stephens, Queensland, Aust.....	Apr, 1920
J. A. Johnston, N. D.....	Apr, 1921	Alex. Zimmer, Ont.....	Apr, 1920
D. H. Laird, N. Y.....	Apr, 1921	Rochenschna, & Son, La.....	Mar, 1920
A. J. Prus, N. Y.....	Apr, 1921	J. Weber, N. Y.....	Mar, 1920
C. A. Butler, Ohio.....	Apr, 1921	Clark Bros, Cal.....	Mar, 1920
E. Mosner, Queens, Australia.....	Apr, 1921	W. H. Leonard, Penn.....	Mar, 1920
W. C. LeBow, Mo.....	Mar, 1921	Ed. Grimm, Tex.....	Mar, 1920
William Pate, Mo.....	Mar, 1921	H. L. Place, S. Australia.....	Mar, 1920
A. T. Jameson, Colorado.....	Mar, 1921	J. Hiernens, Minn.....	Mar, 1920
C. Alexander, N. Y.....	Mar, 1921	G. S. Akers, Va.....	Mar, 1920
J. Fencel, Wisc.....	Mar, 1921	F. White, N. Y.....	Feb, 1920
H. Cornlis, Oregon.....	Mar, 1921	J. H. Wildey, Penna.....	Feb, 1920
C. Schmid, Nebr.....	Mar, 1921	W. Nagowitz, Wisc.....	Feb, 1920
J. Schwarzmann, D. C.....	Mar, 1921	J. F. Leiss, N. J.....	Feb, 1920
M. Stettner, Minn.....	Mar, 1921	C. M. Jacobsen, Utah.....	Feb, 1920
C. Knudson, Iowa.....	Feb, 1921	L. Blough, Penna.....	Feb, 1920
S. Button, Kans.....	Feb, 1921	Hope Bros., B. C.....	Feb, 1920
N. F. Hartsoe, Mo.....	Feb, 1921	A. Standley, Ohio.....	Jan, 1920
L. Koepfer, N. Y.....	Feb, 1921	D. Shearer, Iowa.....	Jan, 1920
R. E. Worthington, N. Y.....	Feb, 1921	J. B. Windle, Ohio.....	Jan, 1920
B. E. Doggett, Kansas.....	Feb, 1921	J. E. Erickson, Minn.....	Jan, 1920
T. Tooes, Kansas.....	Feb, 1921	A. Fisher, W. Va.....	Jan, 1920
Shellhaas & Fry, Colorado.....	Feb, 1921	I. J. Giguere, N. H.....	Jan, 1920
J. W. Wilson, Mo.....	Feb, 1921	E. Gunther, Iowa.....	Jan, 1920
W. T. Wilson, Indiana.....	Feb, 1921	L. H. Willson, Vermont.....	Jan, 1920
J. Schmid, Nebr.....	Feb, 1921	D. R. White, Kansas.....	Jan, 1920
E. Stee, New York.....	Feb, 1921	P. Bianchi, Texas.....	Jan, 1920
A. R. Skerritt, New York.....	Feb, 1921	R. S. Crazier, Ky.....	Jan, 1920
W. H. Starkey, Kans.....	Feb, 1921	T. A. Mahar, Me.....	Jan, 1920
W. Singleton, Pa.....	Feb, 1921	T. Horne, Ariz.....	Jan, 1920
A. Bartlett, Vt.....	Jan, 1921	H. E. Draper, Ind.....	Jan, 1920
E. H. Manley, Mo.....	Jan, 1921	H. H. Schoob, Wyo.....	Jan, 1920
N. C. Abbott, Ohio.....	Jan, 1921	I. A. Coats, Mont.....	Jan, 1920
Neufeld & Giesbrecht, Kans.....	Jan, 1921	W. C. Young, Iowa.....	Dec, 1919
Feldmeyer & Schaeke, Mo.....	Jan, 1921	H. Kraft, Calif.....	Dec, 1919
A. Josepell, Colorado.....	Jan, 1921	S. Barber, Iowa.....	Dec, 1919
C. L. McNall, Mo.....	Jan, 1921	M. Martin, S. D.....	Dec, 1919
A. Turley, Kansas.....	Jan, 1921	R. L. Ryberg, Iowa.....	Dec, 1919
A. Seidel, Nebr.....	Jan, 1921	Daysable & Sons, Vict.....	Dec, 1919
W. Ruple, Pa.....	Jan, 1921	E. M. Crouch, Conn.....	Dec, 1919
N. A. Englund, Iowa.....	Jan, 1921	R. Werk, Nebr.....	Dec, 1919
O. Gerhardtstein, Ohio.....	Jan, 1921	J. R. Wilson, Md.....	Dec, 1919
W. C. Rutter, Illinois.....	Jan, 1921	N. Buchanan, Ont.....	Dec, 1919
J. L. Jester, Mo.....	Jan, 1921	P. Relf, Ohio.....	Dec, 1919
G. A. Moffatt, Yukon Ty.....	Jan, 1921	A. Larsen, Ida.....	Dec, 1919
J. W. Ivie, Utah.....	Dec, 1920	H. Andersen, Iowa.....	Dec, 1919
O. A. Huff, Pa.....	Dec, 1920	I. F. Powers, N. J.....	Dec, 1919
J. T. Rowe, Iowa.....	Dec, 1920	J. G. Grandlund, Conn.....	Dec, 1919
W. Parsons, Ontario.....	Dec, 1920	J. B. Horn, N. Mexico.....	Dec, 1919
Eisler Brothers, S. Dak.....	Dec, 1920	A. L. Barnum, Nebr.....	Dec, 1919
J. Krahelec, Illinois.....	Dec, 1920	J. Mason, Ill.....	Nov, 1919
L. F. Kellhols, Pa.....	Dec, 1920	C. S. Kiang, Pa.....	Nov, 1919
F. Markgraf, Minn.....	Dec, 1920	A. Feine & Sons Co., N. Y.....	Oct, 1919
S. Wright, New York.....	Dec, 1920	T. S. Ehlert, Tex.....	Sept, 1919
T. P. Consodine, Mass.....	Dec, 1920	Geo. Fleckenstein, Calif.....	Sept, 1919
J. D. Fox, Nebr.....	Dec, 1920	C. H. Sandstone, N. Y.....	Sept, 1919
W. Trener, Washington.....	Dec, 1920	L. Pates, Minn.....	Sept, 1919
A. G. Palmquist, Minn.....	Dec, 1920	F. A. Burnham, Ind.....	Sept, 1919
J. E. Richards, Pa.....	Dec, 1920	C. F. Abel, Iowa.....	Sept, 1919
J. Berthelsen, N. S. W. Aust.....	Dec, 1920	P. Lenz, Mo.....	Sept, 1919
D. Coders, Illinois.....	Nov, 1920	E. Faillie, Mich.....	Sept, 1919
C. Franssen, New York.....	Nov, 1920	F. Franklin, Idaho.....	Sept, 1919
J. Delane, Nebr.....	Nov, 1920	W. Duncan, Calif.....	Sept, 1919
J. H. Staats, Mo.....	Nov, 1920	W. Dryden, Ill.....	Sept, 1919
George F. Wardle, S. D.....	Nov, 1920	I. Moyer, Pa.....	Aug, 1919
H. C. Strine, Pa.....	Nov, 1920	J. Owen, Ohio.....	Aug, 1919
C. M. McNutt, Mass.....	Nov, 1920	W. Coang, Penn.....	Aug, 1919
J. M. Mapes, New York.....	Nov, 1920	C. Schnake, Ind.....	Aug, 1919
W. Condon, New York.....	Nov, 1920	O. Jensen, Mich.....	Aug, 1919
F. Strieff, Wisc.....	Nov, 1920	B. Ulmer, N. Y.....	Aug, 1919
L. P. Mortensen, Michigan.....	Nov, 1920	H. Ehman, N. Y.....	Aug, 1919
A. W. Brenneman, Indiana.....	Nov, 1920	R. T. Ray, Mont.....	Aug, 1919



## The Depreciation of the Packing Material Used in Case Hardening

JOHN JERNBERG

Case hardening, as the name implies, consists of hardening a shell of a desired thickness on a soft steel, which without such treatment would not permit of this. A good steel for carbonizing is a steel of about 20 point carbon. A simple heat treatment alone cannot make such steel "glass hard." If the carbon content is raised, say to .8 or .9%, the steel can be made hard. It is this that carburizing does. Carburizing then consists of giving to the shell of the soft steel the proper carbon content which then permits of a heat treatment to harden it.

The method employed in effecting carburization commercially is more or less standardized. It consists of packing the soft steel parts in a suitable container which will withstand the heat and surrounding the steel with a material which is essentially a fixed carbon or one which liberates hydrocarbons and subjecting the whole to heat.

Experiments carried on have confirmed that mild steel or iron absorbs

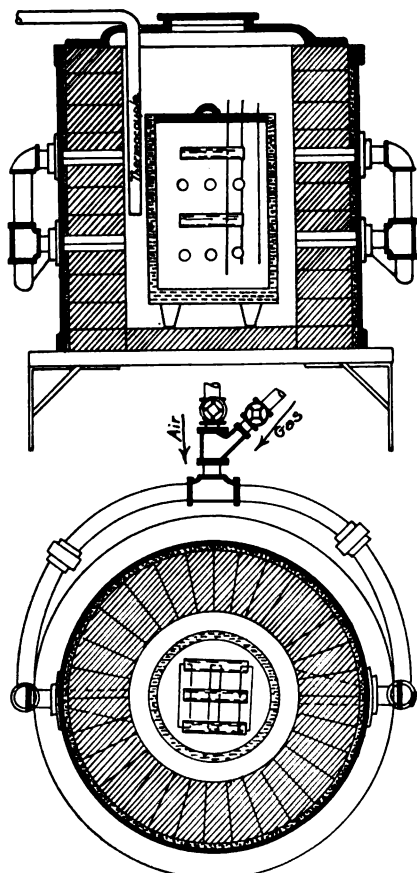

FIG. 1.—THE CARBONIZING FURNACE ALSO SHOWING HOW THE POT WAS PACKED

carbon under the above conditions when heated to 1350 and over; that when a fixed carbon is used carbon-monoxide—(CO) is formed; that the carbon of the carbon monoxide permeates the steel, leaving the oxygen (O) to combine with other carbon; that iron has a great affinity for carbon and forms a saturated solution of ferric oxide (Fe<sub>3</sub>O) when it contains .9% of carbon; that the pressure of CO aids penetration and that the presence of nitrogenous material aids as a carrier of the carbon.

The rapidity of penetration varies with the temperature while the depth varies with the time. The most efficient carburizing is done at about 1650 or 1700 F.

The efficiency of a carburizing material is based on its ability to give a quick penetration; to give the proper carbon content and its cost. With these facts in mind, let us enumerate a few essentials of a good carburizing material. In the first place, as has been said, (A) the case should be formed in as short a time as possible, other things being equal. This is, of course, economical. (B) The material should be as good a conductor of heat as possible and have a low specific heat. These two features will aid in obtaining a uniform case on all the pieces of steel, for it will tend toward heating the middle of the container soon after the outer parts have been heated. (C) There should not be present more than 2% sulphur, especially if moisture is present, for the acid thus formed would pit the iron. Hence (D) the material should be such as to leave the surface of the steel carburized in a good condition. (E) The material should not expand radically when heated since this would distort the contents. (F) the final requirement of a good material is that it shall have the minimum per cent. of shrinkage and retain its carburizing power for many successive heats. It is this last very important feature that we were investigating in this experiment.

The generally used substances for carbonizing have ground bone, leather, scraps, sawdust and charcoal. Bone is objectionable because of its high phosphorus content, while leather scraps are very good but have become very expensive. Sawdust is very unsatisfactory because of its unreliability. Of the four, charcoal is probably the best and most used. Experiments carried on at the Worcester Polytechnic

Institute have proved that a compound, consisting of 94% charcoal, 3% salt and 3% kerosene (by volume) was an excellent preparation. The charcoal is generally of

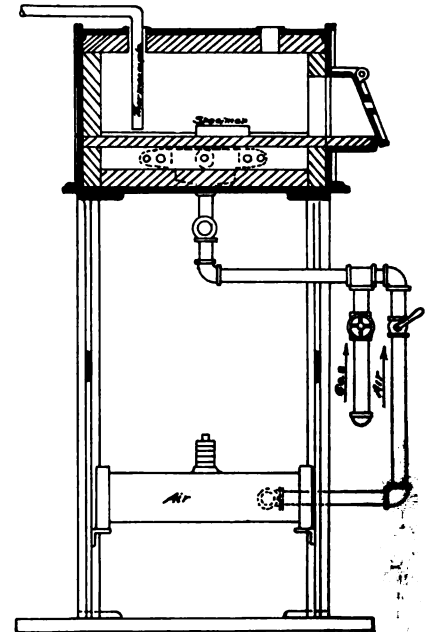

FIG. 2.—THE HEAT TREATMENT FURNACE SHOWING SECTIONAL VIEW OF HEATING OVEN

birch or maple wood, crushed to small pieces, which will pass a sieve having eight meshes per linear inch. There are also at present many preparations on the market which claim some of the desirable qualities cited above.

The object of this investigation was to make a study of the depreciation of the packing used in case hardening. The packing was to receive the same treatment as it might reasonably receive in commercial work and the depreciation, both as to volume and weight, noted. The changes resulting from the depreciation of the packing were the other points to be observed.

The case obtained from any carbonizing compound depends upon four variables: ratio of steel to compound, nature of steel, time, and temperature. In order to accurately observe the depreciation of the compound, in question, we deemed it advisable to keep these four variables constant throughout the entire test. Thus the work was confined to using the same compound over and over again in successive heats of which the time of duration and temperature remained constant. The steel was so chosen that it was practically the same throughout the tests, while the amounts of steel used were



calculated so as to keep the ratio constant throughout the tests.

A temperature of 1650°F was selected and five hours as the length of time for the test. These values seemed to fairly represent conditions to be met in commercial work. Six bars of steel were provided for this work. By fracturing, we judged that three of these were nearly alike and collected sample chips from those which we had analyzed. The analyses gave the carbon contents as .14%, .16% and .19%, respectively. These seemed to be so nearly alike that no distinction need be drawn between them.

The ratio of the area of the steel

The steel was first cut into 9-inch lengths from a 1/4-inch bar. These were turned and filed to a 23/32 diameter and then cut in two, making the finished pieces 4 1/2 inches long. As many of these as was possible were packed into the pot in such a manner that one-inch of packing separated each. Our pot could in this manner hold twelve pieces, packed as shown in Fig. 1.

Having done this, we could now calculate the exact ratio of packing to surface area of steel and keep this constant throughout the test. Thus as the packing

pyrometer, but because of alterations in wiring and misuse, the meter read higher than the temperatures were. For this reason, some of the first temperatures were somewhat low, which accounts for the thin cases and small depreciation at that time.

Heats of five hours duration mean five hours from the time the interior of the pot had reached the temperature determined upon, namely, 1650/Fah. To determine the time

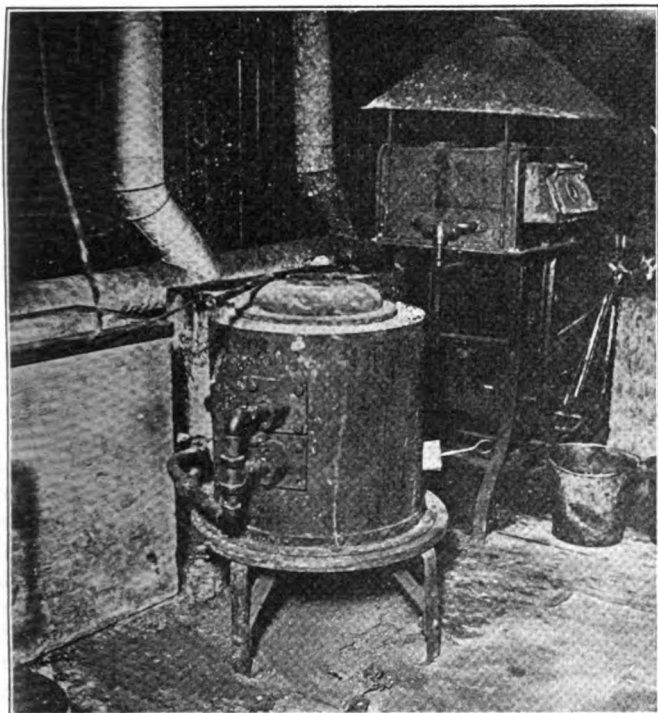

FIG. 3.—SHOWING THE CARBONIZING FURNACE, ALSO THE HEAT TREATING FURNACE

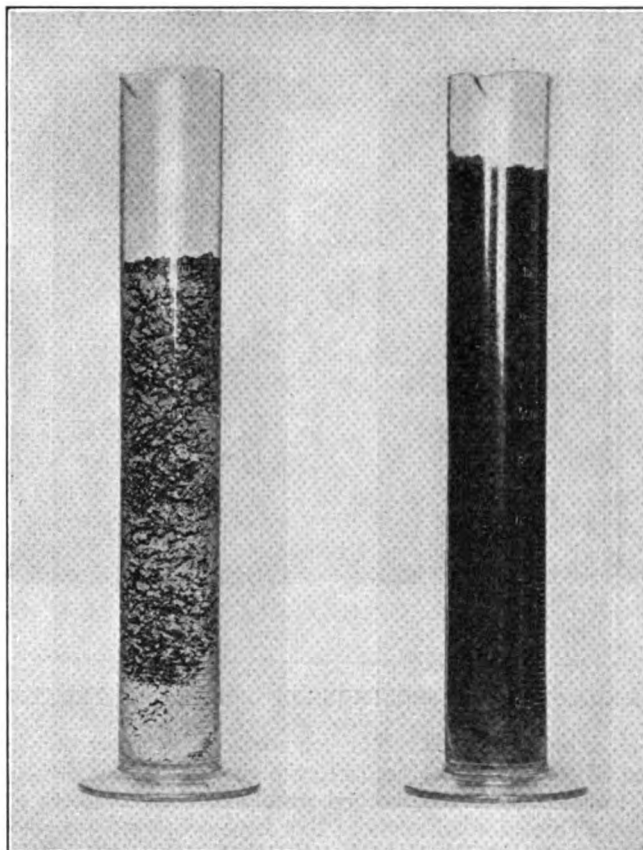

FIG. 4.—THE CASE HARDENING MATERIAL BEFORE AND AFTER USING

to the volume of the packing was determined in the first heat by making the distances between bars and between the bars and the walls of the pot what we considered correct. This will be explained later. The ratio was calculated and the amounts of steel for the following heats were determined by keeping this ratio constant.

As previously stated, of the four variables, viz., time, temperature, carbon content of steel, and steel ratio, we kept the time constant at five hours, the temperature constant at 1650, the ratio of steel to packing constant and noted the variation in the packing. The steel used analyzed 16% carbon on an average throughout all stock used.

shrunk in volume, we accordingly reduced our steel as determined by the ratio obtained. The pot was then covered with the cast iron cover fitting into it and sealed with asbestos putty.

The covering and sealing of any container used to hold the packing and steel is a very essential part of the preparation. To avoid covering would be to disregard one of the fundamental principles of the process, namely, that CO gas under some pressure must intervene the solid carbon and the steel. Obviously, this gas would escape without performing its function. The pot was always left in the furnace overnight to cool.

The temperature was taken with a

it took to do this, we drilled a row of 1/8-inch holes in the cover from the circumference to the center and in them inserted wires which reached to the bottom of the pot. From time to time, while the pot was heating, a wire was pulled out, beginning at the outside. By the color to which the wire was heated, the temperature of the interior could easily be judged. The average time during the first few heats was found to be two hours, so we took this to be constant throughout.

Careful measurement was made of the packing at the beginning of the first heat and after each heat. The cubical content was measured in a 1,000 c. c. graduate as shown in Fig. 6, while the weighing was done

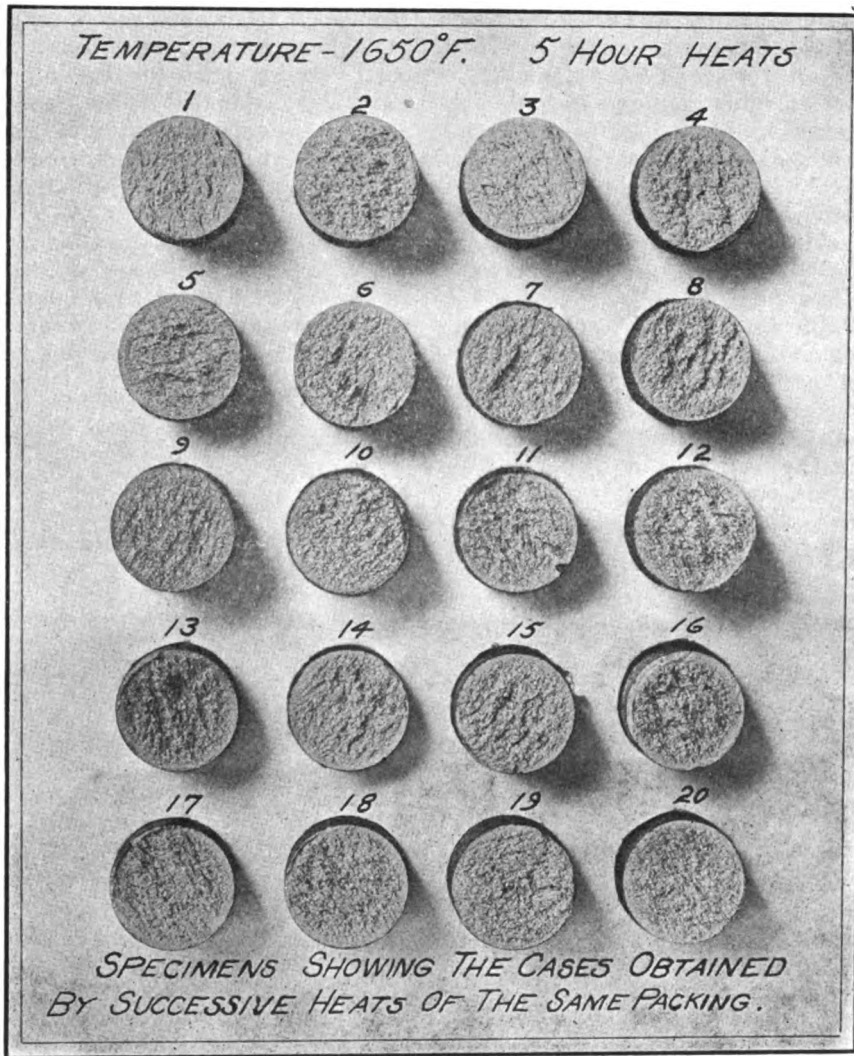

FIG. 5.—BROKEN SPECIMENS OF THE PIECES TREATED SHOWING THE CASE

on sensitive scales. The amount of steel to put in was figured each time from the ratio determined previously. Thus, for 20 heats of five hours each, a total of 100 hours, the same packing was used over and over again, and the depreciation in volume and weight noted each time.

The three pieces of the bottom layer of each heat were carefully marked and put away until the twenty heats had been run. They were then heat treated for the case.

By heat treating for the case we mean hardening the outside shell which was carburized. This treatment gives it the most refined grain structure, besides making it glass hard. When the specimen is then broken a distinct case can be seen around the coarser inner part. To accomplish this hardening the pieces were all heated in a gas furnace (See Fig. 2) to a temperature of 1450°F. and plunged in water. This is the proper hardening temperature for 9 point carbon (.9%) steel. As the carbon contents de-

creases the hardening temperature increases. In commercial practice the core is often treated, first at 1625 to 1650°F., and then the case at 1450. Of course, the grain refining temperature of the core de-

pends on its carbon contents. The temperature for steel such as ours (.16% carbon) is 1650°F. It must be kept in mind that this core does not become hard for its carbon content is too low to permit of such, but that its grain structure is refined, making it very tough. Subsequent heating to 1450 for the case does not destroy the fineness of the core for the critical temperature (1650) had not been reached. The result of such a dual treatment is a steel capable of resisting shock and wear.

The hardening specimens were next broken in two by letting half their length protrude from a hole in a heavy cast iron disk and hitting the end with a sledge hammer. This was quite easily done, for the case, being hard, fractured readily, while the core was quite granular in structure as left so by the rolling mill, for we did not heat treat the core. There was no variation in case thickness in specimens of one heat.

One fracture of each heat was photographed. (Fig. 5). The other half of the same specimen was treated with a dilute solution of nitric acid to bring out a definite dividing line between core and case for measuring the thickness of the latter. The end of the specimen is simply ground and polished (care being taken not to burn the carbon) and a little acid poured on. A dark ring dividing the core and case is the result. With a powerful reading glass and a scale divided into hundredths of an inch, the thickness of the cases were quite accurately read.

To know exactly what per cent. carbon the case contained, .020 inches was turned from the diameters of each of the 20 specimens

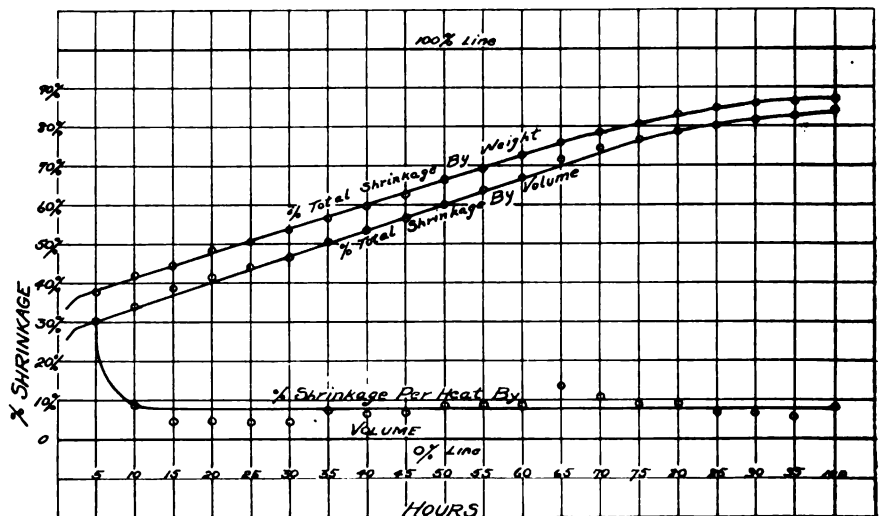

CURVE SHEET NO. 1 SHOWING RELATION BETWEEN SHRINKAGE AND HOURS OF USAGE OF PACKING



and then a thin cut made of which the chips were gathered, the chips of each specimen in a separate envelope. Great care was taken to keep these free from oil for since oil contains carbon, it would make the analysis incorrect. These were then sent to a chemist for analyses.

**Analysis of Results.**

As seen by the curves on Curve Sheet No. 1, the packing depreciated less between the second and seventh heats, both by volume and by weight, than during the remaining heats, owing to the lower temperatures already mentioned. The depreciation during any one heat was the greatest during the first heat, when the packing lost 30% by volume and 38% by weight. As the case obtained with this heat was one of the lowest obtained during the entire series, it is apparent that there was a loss not accounted for.

Probably the pot and cover still absorbed quite an appreciable amount of carbon during this first heat. The large shrinkage let the cover down quite a distance, destroying the asbestos air seal to some extent, and thus allowing the gas to escape. These things all helped to make the first a large depreciation, however, it is very probable that the first shrinkage when the material is new is always the greatest.

The rate of depreciation remained practically constant during the remainder of the heats although it fell off slightly towards the end.

It will be noted that the curves representing the present shrinkage by weight and by volume come nearer together during the last heats. This is explained by the fact that the specific gravity of the packing diminished as the number of heats increased. In the table giving the packing data (Table No. 1) the last column gives the grams per cubic centimeter as determined after each heat. It is of interest to notice that the total change in specific gravity during the one hundred hours of actual use amounted to only nineteen per cent.

The depths of cases obtained averaged .028". Although the depths of the separate cases seemed to vary considerably the number above the average approximately equalled the number below it. As regards the carbon content of the cases the values given on the data sheet do not fairly represent the results obtained. The chips removed from the specimens for analysis were taken at a depth of 10/1000-inch from the sur-

face. As the depth of case fell below .025-inch in five tests, and below .020-inch in three, this was too great an amount to remove before securing the sample chips—as the chips so obtained represented the poorer part of the case.

Fig. 4 shows the change in the condition of the packing due to use by contrasting a sample of new ma-

was carbonized is shown in Fig. 1. This is a circular furnace consisting of a plate steel shell lined with fire brick. Between the fire brick and shell is a thin layer of sand to allow for the expansion of the steel. The bottom is protected from the heat in the same manner as is the shell. Gas from the city mains is burned at the four burners which

No. of Heat	Total No. of Hours	C.C. Packing	Grams Packing	C.C. Total Shrink	% Total Shrink C.C.	Grms Total Shrink	% Total Shrink Grms	Shrink per Heat %	Shrink per Heat % C.C.	Sp. Wt. Grms. per cc.
0		5550	1646							296
1	5	3880	1025	1670	30.1	621	37.7	37.7	30.10	.264
2	10	3550	954	2000	34.0	692	42.0	6.93	8.50	.268
3	15	3400	917	2150	38.8	729	44.4	3.88	4.23	.269
4	20	3240	852	2310	41.6	794	48.2	7.08	4.71	.263
5	25	3110	816	2440	44.0	830	50.5	4.23	4.01	.262
6	30	2980	765	2570	46.3	881	53.5	6.25	4.18	.256
7	35	2760	718	2790	50.3	928	56.4	6.15	7.30	.260
8	40	2590	661	2960	53.3	985	59.8	7.93	6.15	.255
9	45	2420	618	3130	56.5	1028	62.5	6.50	6.55	.255
10	50	2215	553	3335	60.0	1093	66.5	10.50	8.47	.250
11	55	2020	510	3530	63.6	1136	69.0	7.76	8.80	.252
12	60	1840	450	3710	66.8	1196	72.7	11.73	8.90	.245
13	65	1590	398	3960	71.4	1248	75.9	11.54	13.60	.250
14	70	1420	359	4130	74.5	1287	78.2	9.80	10.71	.253
15	75	1310	321	4240	76.4	1325	80.5	10.60	8.75	.246
16	80	1200	281	4350	78.4	1365	83.0	12.50	8.41	.234
17	85	1120	256	4430	80.0	1390	84.5	8.91	6.70	.230
18	90	1040	243	4510	81.4	1403	85.4	5.08	7.15	.233
19	95	980	230	4570	82.5	1416	86.1	5.35	5.76	.234
20	100	900	215	4650	84.0	1431	87.0	6.52	8.15	.239

TABLE NO. 1. SHOWING SHRINKAGE OF PACKING MATERIAL

terial with the remnants of the tests. As is clearly evident from the second picture the packing became fine and dusty towards the end. The particles became so fine and light that it was exceedingly difficult to handle the packing without losing part of it. The finer particles were of a lighter color than were the original ones.

**Description of Apparatus.**

The furnace in which the steel

are located as shown. The gas and compressed air, under a pressure of about two pounds per square inch, mix at the Y-junction after which the mixture divides, half going to the burners at each side of the furnace. Beyond the burners the openings flare in one direction so that the gas enters the combustion chamber in a direction tangential to the walls of the pot. This scatters the gas about the chamber and causes a



No. of Heat	Total Area of Steel (sq. in.)	Ratio c.c. Bk. sq. in. Steel	Depth of Case (Inches)	% Carbon at 1/16" from Surface
1	12755	435	.020	.65
2	8324	465	.029	.73
3	8093	430	.015	.55
4	7923	429	.034	1.05
5	7510	431	.024	.70
6	7000	445	.025	.75
7	6540	455	.019	.68
8	6520	423	.038	.87
9	6040	430	.022	.69
10	5448	445	.036	.92
11	5078	436	.031	.88
12	4783	423	.032	.77
13	4307	426	.032	.89
14	3666	434	.028	.75
15	3295	431	.029	.75
16	3010	435	.039	.85
17	2905	415	.032	.77
18	2577	433	.029	.76
19	2574	410	.025	.74
20	2326	420	.026	.73

TABLE NO. 2 SHOWING THE RESULTS OBTAINED AFTER EACH HEAT

more even distribution of heat than would be obtained otherwise.

Because of the comparatively low temperature of the heats it was possible for us to use an iron crucible. This we secured from Browne and Sharp Company of Providence, Rhode Island. As this crucible was made to withstand a temperature of 2300°F., the heats we subjected it to had little effect upon it. As any metal crucible will deteriorate, owing to the oxidizing action of the air, the walls of this crucible became so thin that another—exactly like the original—was used for the last two heats. The dimensions of these crucibles were: outside diameter, 8 inches; inside diameter, 7¼ inches; inside height, 7½ inches; overall height including the 1-inch legs, 9¼ inches.

We made a cast iron cover for the crucible, ⅜-inch smaller than the inside diameter. This was to allow for the warping of the walls. As this cover fitted inside the pot it always rested upon the packing, thus preventing any air space. In order that both the walls of the pot and the cover should not tend to absorb carbon during the first few heats a trial heat of seven hours was made

with the crucible filled with packing. The temperature of this heat was about 1900°F.

Fig. 2 shows the furnace employed for heat treating the carbonized steel. This furnace is made with a metal shell lined with fire brick in the same manner as is the carburizing furnace previously described. It also resembles the latter in the fuel used and the manner of mixing the air and gas. This is clearly shown. The mixture of air and gas enters the combustion chamber on the two sides through manifolds. The specimens to be treated are placed upon the bridge which extends the length of the furnace, the combustion taking place between the bottom of the furnace and the bridge. Air is stored in the cylindrical tank near the bottom of the furnace. The pressure of the air leaving this tank can be varied by means of changing the weights upon the relief valve.

The temperature of the furnace is measured by means of a Bristol Indicating Pyrometer equipped with a thermo-couple of comparatively high electromotive force. At the beginning of our work we had two new thermo-couples. Testing the pyrometer with these thermo-couples attached we found that the pyrometer needed adjustment. Using a LeChatelier Pyrometer equipped with a platinum-rhodium thermo-couple as a standard, we changed the resistance of the Bristol Pyrometer until the latter read correctly. We then checked the readings by means of fusible salts.

A Bristol Pyrometer, when properly adjusted, is a very good instrument for practical work. As the low resistance thermo-couples will withstand a temperature up to 2300°F. such an instrument will give as good service in heat treatment work as will the LeChatelier Pyrometer, although the more sensitive instrument is better suited for laboratory work.

#### Conclusions.

Although our work was not done with the utmost precision, yet the results fairly represent what might

be expected in commercial work. For example, it was rather difficult to measure the volume of the packing material after each heat with great accuracy, because it assumed a smaller volume when the graduate was jarred. However, we endeavored to jar each measuring the same. Then also our temperatures were somewhat low during the first heats as was before mentioned.

With due consideration of these facts we conclude:

1. That this case hardening compound has a low rate of shrinkage.
2. That the carbon content of the case is as it should be.
3. That this material has a most remarkable endurance as to its ability to carburize, the cases being as good and as thick after some 100 hours of use as at the beginning or intermediate heats.

Had time allowed we could have run the material for several heats more with probably excellent results.

## Notes on the Theory and Practice of Hardening

JAMES CRAN

On reading an article under the above heading, which appeared on page 295, Vol. 15, THE AMERICAN BLACKSMITH, the writer got several surprises, the principal one of which was the description of a heating machine said to be used in the hardening of blades of pocket knives.

While the description of the machine in question might pass the average reader, as the appliance generally used for the purpose, the writer considers it only fair that they be given facts.

Before proceeding further it may be well to explain that the machine described in the article referred to was originally designed and used for the hardening of balls for ball bearings. It has, however, in recent years been modified and improved to such an extent that it is now used for the automatic heating of a large variety of small pieces, but not for the blades of pocket knives for the

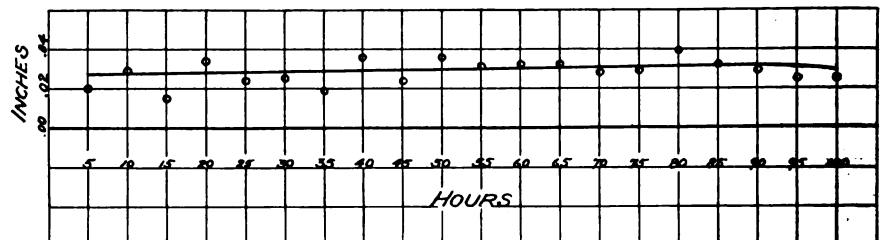

CURVE SHEET NO. 2 SHOWING RELATION BETWEEN THICKNESS OF CASE AND SUCCESSIVE HEATS OF PACKING



reason that in following the spirals of the screw while going through the machine they would be tumbled in all directions and when delivered to the bath, they would as likely as not, enter it on the flat.

It is hardly necessary to explain to any one who has ever done hardening that it is of the utmost importance in the hardening of such pieces as the blades of pocket knives, to dip them in the bath, end first, to insure their being straight. The machine generally used for the automatic heating of blades for pocket knives and similar articles made from high carbon steel consists of a gas heated oven mounted upon legs. Just below the heating chamber there is a chain rotating upon sprocket wheels, one at each end of the machine. Attached to the chain are pins several inches in length, which project through a slot in the lower side of the heating chamber and carry receptacles specially constructed to accommodate and keep in position the articles to be hardened, so that when they have left the horizontal and assumed a vertical position in passing over the sprocket they will enter the bath, end first.

It might be well to explain that these automatic heating machines are operated by power through a speed regulating counter shaft. The heat is gauged by a pyrometer and the point of recalcence at which the carbon in the steel changes form can be determined by the use of an electro magnet. It might be well to explain that when steel, regardless of its carbon contents, has been heated to the critical point, or point of recalcence, it loses all magnetic attraction and is in proper condition to be quenched for the best results. Therefore, it stands to reason that with an automatic heating machine having its heat gauged by a pyrometer, a speed controlling regulator and a magnet to determine the correct degree of heat for the best results, that better and more uniform hardening can be done than is possible in following the old-time method of guessing at it.

While the tempering machine described by Mr. West may be used for drawing the temper of pocket knife blades, attention is no longer paid to color. The heat for tempering is gauged by a thermometer placed in one end of the drum, but the higher grade of blades are tempered in an oil bath which is usually heated to from 550 degrees to 575 degrees Fahr. according to the qua-

lity and carbon contents of the steel. Usually when the temper is drawn in oil the blades are allowed to remain in it until it has cooled down, as the longer steel retains heat after tempering the tougher it will be.

There seems to be no question about the hand forged knife blade being superior to those made by the drop forging process when the same steel is used in both methods of forging. But to overcome this a finer grade of steel is generally used when the blades are drop forged, to compensate for the hammer refining in hand forging.

The reason for so many of the blades of pocket knives being soft, and it has to be admitted that a vast number of them do not give the satisfaction that their cost warrants, is that they are overheated in polishing. Another thing, particularly in this country, that places U. S. and the knives made here at a disadvantage to those made in England, is that in the majority of cases the English knife maker is the descendant of generations of knife makers and the business is to him like second nature; whereas in this country the knife maker is often the victim of circumstances, or in the business for the remuneration derived from it and while there is no doubt about most of them putting the best article they can on the market at the least possible cost to the consumer, the hereditary element so pronounced in the Englishman is lacking.

Referring to the retempering of the blades of pocket knives when they are found to be too soft for satisfactory service, it is not necessary to remove them from the handles. The method followed by the writer, and it has almost invariably proved satisfactory, is to thrust the blades to be rehardened through a raw potato until nearly all of the blade is exposed and the bolsters on the handle are entirely covered. Bend a piece of flat stock to the shape of a U, about 3/16-inch wide inside, heat this to a bright red and place the blade inside the U with the point projecting slightly through it. This is to prevent the point, which is the slimmest part, from getting heated before the rest of the blade. When the blade has absorbed what may be considered the right amount of heat it should be quenched, back first, in either fish, linseed or cotton seed oil. As soon as cold, polish the blade and draw the temper to a purple color,

using the same piece and the same heat as was used in hardening. The raw potato will effectually protect the handle and it will bear no unsightly marks to remind you that it did not always prove satisfactory.



## Benton's Recipe Book

Axe dressing, hardening and tempering seems to be giving one of our Western readers considerable trouble. After looking through the recipe book, I would suggest his trying the following: After heating your axe-blade to a deep yellow, commence to draw out by hammering, beginning at the cutting edge and going all away across the bit, first on one side, then on the other, until the heat begins to get low and the edge is drawn as thin as is necessary for an ordinary chopping axe. Now, take another heat, this time about one and a half inches back from the cutting edge, and heat to a good yellow. In hammering after taking this heat, hammer in a line about one and a half inches back from the cutting edge and hammer, first on one side and then on the other, the same is in the previous operation. The axe has now naturally widened out and if too wide, cut off on both sides with a chisel, but do not attempt to hammer this surplus metal back into the blade after cutting off to the required width. Heat the blade again, this time to a low heat, and hammer carefully and evenly all over the flat surface on both sides at about one and a half inches back from the cutting edge. Now allow the blade to cool and then file up smooth and to proper shape. The blade is now ready for hardening, this is done by heating the bit slowly and evenly for not less than one and a half inches back from the cutting edge. The heat being a cherry red. Now, dip the cutting edge into the hardening bath, raising and lowering it, so as to cool it gradually, and not too quickly, which would produce strains in the steel. Now, polish the hardened part, and heat it very slowly over the fire, moving it back and forth so as to ensure an even, careful heat, and heat until the whole bit of the axe for one and a half inches back from the cutting edge, will show a light blue. The axe is then cooled off and is ready for grinding.

Another welding compound comes to us from one of our Eastern friends. This mixture being recommended for springs. Take a quantity of calcined or burned borax, and for each ounce of borax take two ounces of beeswax, and about two ounces of resin, mix these ingredients carefully and thoroughly, and use the same as plain borax.





### Queries - Answers - Notes

## Tractor Plow Construction and Adjustments

Address by I. A. WEAVER before Am. Soc. Agr. Eng.

In discussing modern engine plows we will divide them into two classes—the light duty, rigid beam built in two, three or four bottoms, and the large, flexible beam type of four bottoms and larger. To the casual observer it might appear that the only problem involved in designing the light tractor plow would be to arrange a special hitch on a horse-drawn plow or to attach a number of walking plows to a platform mounted on wheels to make the large flexible beam plow.

It is an imposing sight to witness a large plowing outfit operating in a large field under favorable conditions and in soil uniform all over the field. However, they are not always operated under such favorable conditions. Sometimes the field is full of stones and grubs or the ground so hard that it is impossible to plow with horse plows. Again, the same type of plow bottoms is expected to do good work, running from a few inches in depth to a depth that is impossible to go without special type bottoms.

It would be interesting, if time permitted, to go into the detail construction of the various makes of engine plows in

**EDITOR'S NOTE**—This address by Mr. Weaver should be read by every plow repairman who is desirous of getting a better understanding of plow operation. No implement repairman can know too much about plow operation. This article is full of information.

general use, but we can only discuss some of the general features found in all of them. Engine plows must necessarily be stronger than horse-drawn plows as they are expected to work in harder ground and go deeper, also from the fact that the draft of the engine is much different than with horses. A four-horse team on a gang plow could easily straighten out one of the beams, yet there are few beams bent for the reason that they will not exert their full energy when an obstruction is encountered. This is quite different when the plow is drawn with an engine.

Owing to the peculiar construction of the flexible beam plow it must be much heavier per bottom than the rigid beam type, as with the latter the entire weight of the plow, including the axles and wheels, would be thrown on the bottoms to assist them to penetrate if necessary; while with the flexible beam type about 50 per cent. of the entire weight is in the platform. Even one end of the beam is held up by the platform which leaves but a small per cent. of the entire weight of the plow on the bottoms.

There are just two things that will cause a plow to take to the ground—suc-

This is shown in Fig. 1, which shows a plow drawn by a horse. In this case the power is applied at the horse's shoulder and the point of hitch on the beam is approximately in line with the center of resistance on the plow. By raising or lowering the point of hitch the line of draft is not changed but the point of the plow is raised or lowered to make it run the depth desired.

Fig. 2 shows the two extremes of the high and low hitch of a plow attached to a platform. It will be observed that the low hitch has the advantage of the high one in this respect.

The instant the plow starts into the soil it goes forward in relation to the point of draft and the deeper it goes the greater this movement increases, or the higher the hitch the greater the increase. This is also largely effected by the length of the beam. The long beams have the advantage over the short ones in working qualities but require greater strength in order to overcome the increased leverage to hold against the side pressure when the share engages an obstruction and to insure even width with furrows.

This type of plow must be provided

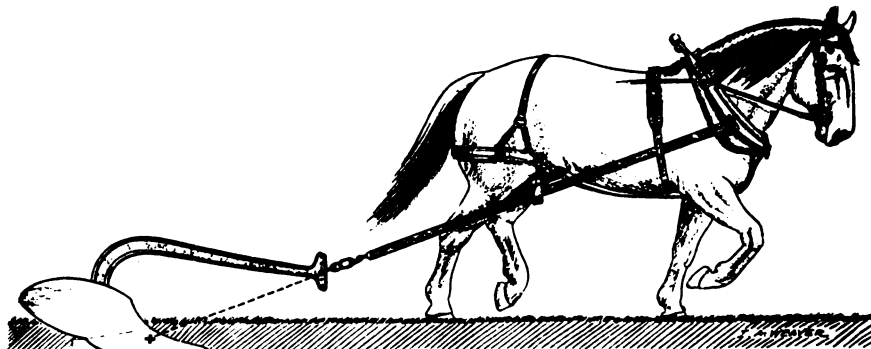

FIG. 1.—RAISING OR LOWERING THE POINT OF THE HITCH RAISES OR LOWERS THE PLOW'S POINT

tion and weight. Suction is created largely by the point and does not differ much in the different makes of plows. A thin shaped point will penetrate and pull easier than a thicker one but would wear away faster and could not be sharpened as often. As the points begin to get dull it requires considerable weight to keep the plow in the ground.

Contrary to the general opinion, the height of the hitch hinders the plow from taking the ground instead of forcing it in.

with a gauge wheel to regulate the depth and elevate the plow and is usually controlled by a lever mounted on the beam. This wheel must necessarily be placed between the end of the beam and the bottom. When the wheel passes over an obstruction the bottom is elevated higher than the obstruction. This defect is largely overcome by mounting the lever on the platform and connected to the gauge wheel with a compound connection. As a plow usually cuts 14 inches there is a limited room between the bottoms and coulters for the wheel. If too close to the rolling coulters they will cause trouble in certain soils and in other positions will cause the plow to choke where there is much trash. Therefore, in designing a plow of this type the locating of the gauge wheel demands the most careful consideration of all possible condition contingencies to be met with in operation.

The coulters should be strong and capable of having an adjustment that will set them near the point of the share so that in soil full of large boulders, such as are found in the northwest, they will throw the plow over these obstructions and prevent breakage. Ordinarily the coulters should be set about one-third of the depth of the furrow and about 1/4 of an inch to the land. If set too far back and too far to the furrow side the pressure will be light above the shin of the plow which will retard the scouring. In



A TRACTOR PULLING SIX PLOW BOTTOMS AND A HARROW



soils full of loose stones and gravel a jointer will usually work better than a rolling coulter which has a tendency to ride over the small stone. When equipped with combined coulter and jointer the scouring qualities are also affected if too

the fact that many operators will supply iron pins rather than go to the trouble of putting in the wood ones.

In fields where there are high ridges by reason of the crop being planted in rows, the rigid beam plow will require less at-

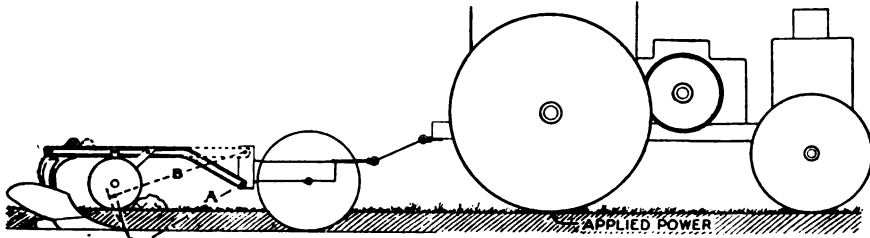

FIG. 2.—SHOWING THE TWO EXTREMES OF HIGH AND LOW HITCH WHEN PLOWS ARE ATTACHED TO PLATFORM

much soil is turned in front of the shin of the plow.

The engine plow generally operates a little deeper than the horse-drawn plow. In a field that has been cultivated for years at a depth of, say 5 inches, the soil is sometimes loose and mellow to that depth while below it may be of a very soggy, sticky nature and if you attempted to go 8 inches deep the face of the moldboard would be covered with a layer an inch thick of the heavy, sticky soil which the loose soil would be unable to push off and as a result, the plow would be prevented from scouring. Under these conditions it is necessary either to go a little deeper and secure greater pressure on the face of the board, or plow a little more shallow.

With plows having more than four bottoms the force required to pull them is greater than the strength of each individual bottom, which makes the break pin hitch impractical. It is, therefore, necessary to provide some safety device, usually in the form of a break pin on the plow standard. These pins are generally of wood, about one inch in diameter.

In many cases when an obstruction is encountered the pin will not shear clear off but will be crushed and will throw the plow on the point and the board out of position. The longer this leverage the smaller the pin and the less the point would be thrown out if the pin was partially crushed, as shown in Fig. 2.

I have experimented with cast iron pins that would break with a force of 3,500 pounds applied at the point of the share and found that if the pin is supported between two supports it is necessary to have it necked shorter than the space between so when it breaks if it should fracture at an angle it would not wedge between the supports.

With the smaller type of plows the break pin hitch can be used very satisfactorily. These wood pins should be long enough so that they may be driven in several times to avoid the waste of time in supplying new ones. The difficulty experienced with all forms of break pins is

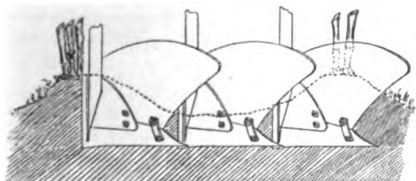

FIG. 3.—PLOWING IN A FIELD WHERE THERE ARE HIGH RIDGES

tention than the flexible beam where the depth of each plow is governed by a gauge wheel.

By referring to the diagram (Fig. 3) you will note that the plows running on top of the ridge would not go deep enough while the one between the ridges would be too deep. It would then be necessary to lower the depth of the plows on the ridges and raise the one between the ridges so the bottoms of the plows would be practically level. The result would be practically the same as with the rigid beam type. However, with the light plows it is necessary to change the land wheel to keep the plow level under these conditions.

In the light duty plow the depth is controlled by the two forward carrying wheels. One of these wheels runs in the furrow and should be at least 3 inches from the bank of the furrow. It is not necessary to run it in the corner to govern the width of the cut as with horse plows, as the lighter engines are either made self-guiding or arranged so that the width can be governed very closely. This will allow for a greater variation when making the turn so the wheel will always drop in the furrow. If it does not, some distance will be traveled with the front plow practically out of the ground.

These plows are generally provided with a rear furrow wheel. This wheel has nothing to do with regulating the depth. The object of it is to relieve the pressure from the bottom of the plow and from the landside and to assist in transporting. However, they are not effective in relieving the side pressure unless some provision is made for the wheel to force the landside from the bank and lock it in that position until the end of the field is reached. With plows having two wheels this is accomplished by setting the wheels on a slight angle to relieve the side pressure for the reason that a stiff hitch is always used. The pressure on the bottom of the furrow can be largely relieved by adjusting the hitch up or down. The two-wheel plow has the advantage over the three-wheel plow in backing.

There is a great deal said about engine plow hitches. This one thing has caused more trouble than all the others. However, there is little said about the hitch on the engine. To my mind this is as important as the plow hitch. I saw a four-bottom plow behind an engine capable of pulling six or eight plows. Naturally, the center line of draft of the engine and plow was from 2 to 3 feet out of line. It was necessary to hitch the plow to one side of the center of the draw bar, but no

up and down adjustment was provided. The parties were attempting to run the plow quite deep and used a short hitch.

The height of the angle was such that it pulled the back of the engine down, removing most of the weight from the front wheels. With the weight removed from the front wheels in this manner and the pull coming to one side of the draw bar, as described above, the front wheel was swung over into the deep furrow where it was impossible to get it out without considerable trouble. The effects of side drafts by the long and short hitch is shown in Fig. 4.

Angle "A" shows an extremely short hitch; the line "B" shows this hitch flattened down about 50 per cent. By moving it still forward an equal distance we have the angle "C." It will be noted that when moved to "D," the angle is getting so slight that there is no particular advantage gained. The long hitch is especially advantageous with the disc plow.

There is a general opinion among farmers and operators of the traction engines that the short hitch makes lighter draft and that there would be an advantage at the end of the field with a short hitch. Both are mistaken ideas; 2 or 3 feet of extra chain will not make any difference on the turn if the outfit will work better.

A good way to start out with a large

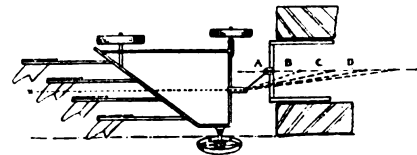

FIG. 4.—SHOWING THE EFFECTS OF SIDE DRAFT BY LONG OR SHORT HITCH

engine and small plow is to make the hitch extra long, then shorten it up from time to time until you get the best results. In other words, the correct length of hitch is where the plow and engine work best.

A Letter from New Zealand—In regard to the automobile and horse vehicles; the motor vehicle will increase for pleasure and commercial uses. Thus the farrier, more than the general smith, will have less to do. That is, should the present number of farriers continue. The general smith must become more of an up-to-date machinist in New Zealand and through the North and South Island a great number of shops are closed up. Depression has effected the aged smith; again a large number of young and middle-aged men have gone to the war. Still I think we have good ground for hope. Horses will be with us; farriers will be wanted. The general smith, we cannot do without. They are both branches that must have plenty of muscle. But oh! "Tell it not in Gath, publish it not abroad", a good bit more brains into the business would give 50% more income and a 100% better surroundings. The farrier is worthy of a high mark of professional dignity.

No Name But Well-Known.

A Straight From the Shoulder Talk:—Today many smiths are turning away auto work, just because they are not prepared to do it, haven't got the tools. All last winter they sat around the fire, smoked and chewed and shod a horse occasionally, and never once got up from



their seat to go to the forge to make a tool.

Great Scott, boys, wake up! here we are at the turning point of our trade. Raise your prices, cut out your dollar shoeing, tell your customers shoes are too high. Tell them you can't do it. Cut out the long credit work. Take chickens, corn or wheat for your work rather than credit. If you give credit, make it sixty days, and then insist on your pay. Tack up a sign: "Don't ask for credit, when you have a bank account." That sign is a good one, if a farmer comes in and has 50c worth of work done, says he "ain't got the change," tell him to give you a check for \$1.00 and give him the change. It isn't going to make a farmer mad to ask him if he has money in the bank. If he has he surely won't get mad at your asking him to give you a check.

How many blacksmiths have you ever seen as presidents of a business association of the business men of your town? A smith doesn't feel at home at one of these meetings and he is made to feel that way. He is a thick head, a num-skull, according to the judgment of the farmer and the merchant. And in my estimation the average smith is all of these and a sucker and an easy mark beside. He is afraid to ask for what is rightfully his.

Yes, I know, I'm one of them, but you bet your life, I'm turning a new leaf. If we boys would take advantage of some valuable information set forth in "Our Journal" on the management of business affairs and quit this monkey business of watchful waiting, we wouldn't always have jobbers, grocers and others shoving overdue bills under our noses.

Cut out this business of "jolly" blacksmith. If you drink, cut it out. Be a man among men; when you talk to your customers, talk sense and when it comes to business, make it business. It doesn't hurt your customer's feeling a bit more to tell him "NO" when he asks you for credit, than it hurts you when he says "NO" when you ask him to pay his bill after trusting him.

The average farmer thinks you are easy and he doesn't care anything about your welfare. He doesn't worry about your sick folks or your grocery bills. He doesn't have to worry about something to eat. He can get through easy because he can come to town and work the grocery and exchange farm produce for due bills. But, mind you, he doesn't say: "Here, smith, I've got some chicken, potatoes (or whatever it is) and I want this work done. How much will it be?" That would make the blacksmith break down and cry. No doubt, he would say: "No bother, I don't want the chicken. If you haven't the money I'll be glad to charge it."

Let us, one and all, be more business like. Let us insist upon our rights: a fair profit for our work, prompt pay and then let us conduct our business so as to insure the respect and confidence that we rightly deserve.

This talk has come straight from the shoulder. It isn't necessary to tell at which class of smiths it is aimed. Those for whom it is intended will take the truth to themselves. Those smiths not hit will be glad to know some one of the craft has had the courage to talk out straight from the shoulder.

JOHN DENBO, Illinois.



## The Automobile Repairman

### Painting the Automobile Quickly and Cheaply

M. C. HILLOCK

Get the car up on some strong wooden horses to let the wheels swing clear. If it can be put up high enough to allow one to work under it conveniently, so much the better. Remove the wheels and start to clean the chassis. First saturate the parts with a mixture of one part crude oil and two parts of turpentine. Let this soak in for a while, over night, if possible. Then with steel scrapers, putty knives, and scraping knives proceed to work the grease and surface accumulations from the surface. The professional painter usually charges anywhere from \$5 to \$10 to clean the car ready for painting; perhaps you may be situated so that you can do it for \$2, or at most, \$3. It is a big job

anyway, and if it is well done it will be worth all that "the traffic" will stand. A car, nicely and thoroughly cleaned is partly painted, is the way the painter puts it, as a rule. It will be a hard job to get all the traces of oil and grease, and probably renovator, off the car body. The best way is to rub the surface with water and pulverized pumice stone, and then wash clean with cold water. Next, look the job over and with a bit of oxide paint, applied with a small pencil brush, touch all places from which the paint has been knocked off, or all places, in fact, which show flaking or fracturing of the paint. The purpose of this is to get these spots coated with a paint carrying oil and pigment specially designed to stick fast to the metal or wood, as the case may be, and to hold up the color to come next. Some, if not all, of these spots will need puttying with a hard drying lead putty, in order to fetch the cavities up level with the surface, as a whole. This putty will dry over night. Then sandpaper it down to the level with the rest of the surface. Next touch the spots with the body color, and then a little later coat the body surface over entirely with color, japan ground, which in a short time will dry firm. Next flow on a coat of varnish-color, and when this is dry, lay the gloss down by rubbing lightly with a soft wool sponge dipped first in water to moisten it, and then brushed across a bit of pumice stone flour. Clean up carefully; washing through a couple of water supplies, dust off well, and

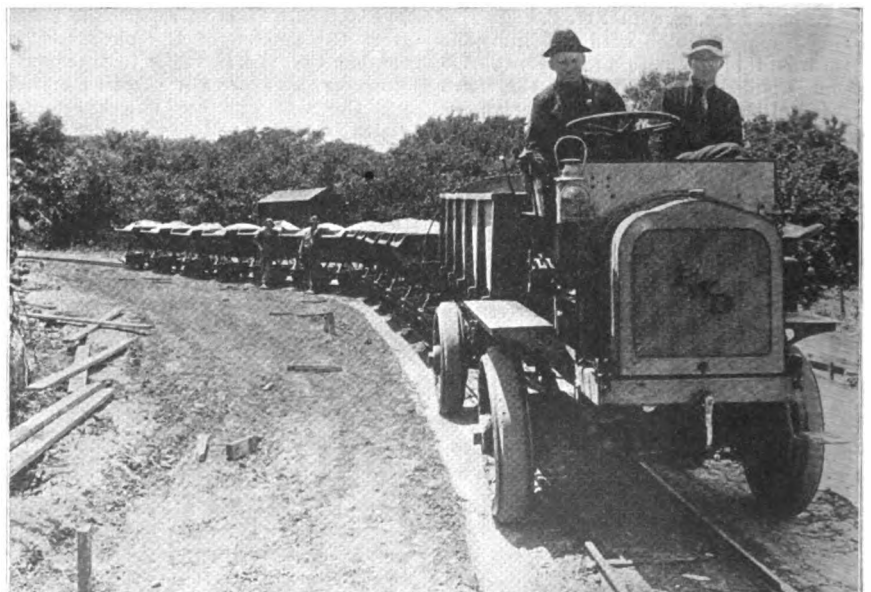

THE MOTOR TRUCK AS A LOCOMOTIVE PULLING TWELVE CARS CARRYING A LOAD OF TWENTY-EIGHT TONS



flow on a coat of durable car body finishing varnish.

The chassis or running parts, after cleaning had best be looked over, and wherever the paint is chipped or worn off, the places may be touched up with the same oxide paint used on the body. If necessary, putty these spots, sandpaper down in due time, touch with the color to be used, and then coat the parts in solid with the color selected. Choose a color in harmony with the color used upon the body; always a lighter color, for best results. Now apply a coat of varnish-color, which can be made of 4 ounces of color and one pound of varnish, quick rubbing varnish being best adapted for the

If desired, the job can be cheapened to the extent of \$5, at least, by omitting the coat of color. Simply touch up the surface defects, as above noted, and then flow on a coat of varnish-color. For the modest priced job this method has its advantages; it reduces the cost materially, and furnishes a durable piece of work.

Some car owners even suggest leaving off the finishing coat of varnish, letting the car go in what has been named "the house paint finish." For the minimum low price job, the work may be surfaced as already directed, touched with color, and next coated with one application of the varnish-color, increasing

panel bodies is simple, but when the customer desires a special body one must exercise considerable ingenuity to overcome certain handicaps attendant upon this work. Such a job came to the writer a few months ago. The customer was an undertaker who had in service a very fine horse-drawn hearse or funeral car with glass sides. He desired the body so altered that it could be adapted to a Pierce-Arrow chassis, and also wished it to be equipped with a driver's cab.

It is interesting to note that the job was offered to a large concern in New York and that this company stated that the work could not be done unless the frame of the chassis

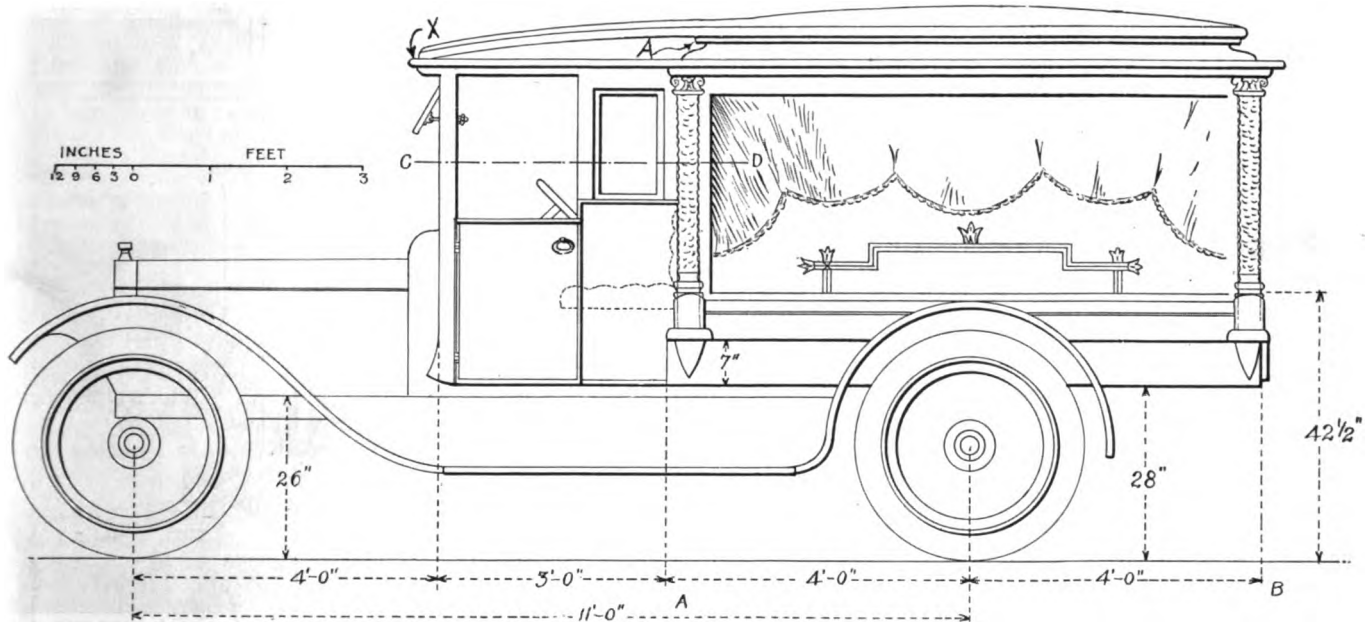

FIG. 1.—SIDE VIEW AND DIMENSIONS OF HORSE-DRAWN HEARSE BODY ADAPTED TO PIERCE-ARROW CHASSIS

purpose. The following day apply a coat of hard, drying gear or chassis varnish, putting on all the surface will carry, as a means of bringing out the fullness of finish. The finish may be made in six days safely. It is a quick and good job, and if reliable paint and varnish is used, not necessarily the finest and most elastic of varnishes, but a good, trustworthy article, the work will stand well and give good value for the investment. In the small town such a job should fetch, at least, for a four-passenger car, anywhere from \$35 to \$40, and for additional work proportionately higher figures. The putty mentioned above is mixed as follows: Dry white lead, 2 parts, by weight; best bolted whiting, one part, by weight. Liquids, equal parts of rubbing varnish and coach japan. Mix to a condition to handle freely without sticking to the hands.

the quantity of color, in proportion to the amount of varnish, to the extent of two ounces of color, making the proportions six ounces color and one pound of varnish. This will deaden the gloss, increase the covering properties, and bring the finish quite up to the house paint gloss. A four-passenger touring car can be turned out by this method for about \$20, at a fair profit, one job with another.

### Converting a Horse Drawn Hearse Body to Fit an Automobile Chassis

L. T. ARMSTRONG

The converting of horse-drawn vehicle bodies into designs adaptable to the automobile is work that the blacksmith and carriage builder is frequently called upon to perform. The fitting of delivery, express and

was extended and several other alterations made. The firm also stated that even with the added wheelbase the body would have too much overhang and advised against the job on account of the looks an expense. Another concern figured on the work and its designers advised against it.

The specifications were submitted to our shop and the customer frankly stated that while he had been advised that it was not practical he believed it could be done satisfactorily and without undue expense. The specifications were turned over to me and after considerable figuring I received the order to go ahead with the work. While the work was in progress many opinions were expressed by those familiar with body work. Some stated that the body would be too high, that the tables would make it awkward in handling



caskets. Others remarked that the use of glass sides on an automobile would not be practical with the job, that the glass would crack owing to the weaving of the frame and the road shocks. Relative to the last objection, it is interesting to note that the car has been in service several months and that the glass is still intact although it travels some very rough roads.

One of the features of the job is that every inch of space was utilized in front of the driver's cab. As it was desirable to place the body as far forward or ahead as possible, it was hung with centers between the pillars exactly over the centre of the rear axle or 4 feet each way, as may be noted by the dimension plan shown at Fig. 1. The value of this suspension is that the load is evenly distributed and that there is less opportunity for the car to skid when traversing wet roads.

One of the difficulties I had to overcome in the design was the driver's cab. I found that it had to be constructed much wider than the old or horse-drawn body, as with the Pierce-Arrow chassis the steering wheel and column set out pretty well and the emergency and gear-shift levers were more so. I solved the problem by using swell panels and by curving the frame or sides until the widest part or section was one-inch inside of the panel rail, X, which was lap spliced, making a continuation and showing no break.

The front pillars were cut vertically near the center line to obtain a full side view, and the frame of the cab was fitted to it as shown in the sectional view at top. The right hand side of the driver's cab has a blind door. The cab, being so wide, was going to make it difficult of entrance and exit, so the only door, (which was on the left hand side) was continued down to the bottom of the body. A section of the floor was cut away and a piece attached

to the door so that it would swing with the door. This provided ample room.

The location of the gasoline tank so that it was easy of access for replenishing the supply of fuel and for repairs, was under the front seat as the supply to the carburetor was by gravity. The seat bottom was made hinged and the front under the seat constructed to be removable. With this arrangement the tank is readily accessible and without displacing the body as usually is the case with the supply under the front seat. This point should be taken into consideration by designers of motor car bodies, particularly heavy vehicles.

As may be noted by the illustrations the side finish of the old body was left at A, over the front pillar. The extensions of the roof show but a slight break where joined and this is, I believe, considerably better and better looking than to have attempted exact continuations which would not obtain the exact curve.

The driver's cab is sufficiently high to permit the operator wearing a high hat. The cab windows are of the stationary type and the panel work is all metal. The chassis frame is what is known as the kick-up style, and the appearance of the body was greatly improved by the use of a 7½-inch base, as shown at Fig. 1. This gave a well-balanced appearance. Filler pieces were placed under each pillar or column; another good feature.

It has been argued that the use of glass panels in the rear of a funeral car is not practical as they will crack owing to the weaving movement of the frame of the automobile. As previously stated, the car has been in service several months without damage to the panels. There are two edge sills of steel on the wood sills of the old part, 3 by ½-inch, which extended to the front of the driver's box on the old body.

These were hack-sawed off at the front pillars. This makes the old part of the body as stiff and as rigid as with a steel frame. The sub sills employed are 2 by 3 at the rear, plated and reinforced with steel

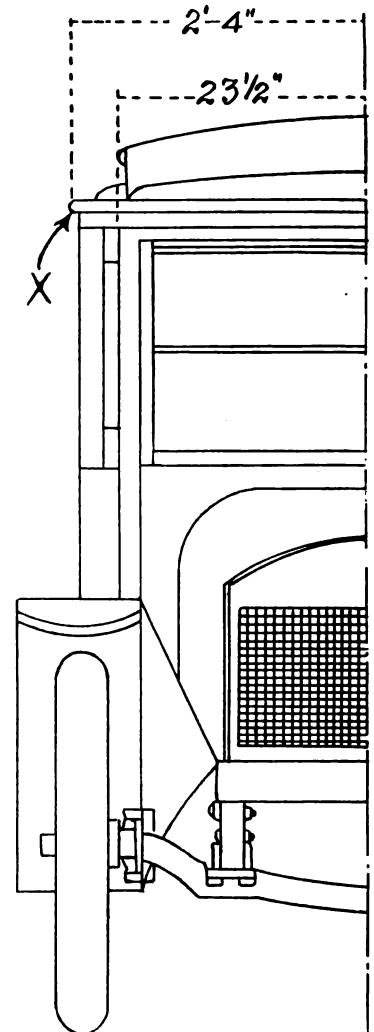
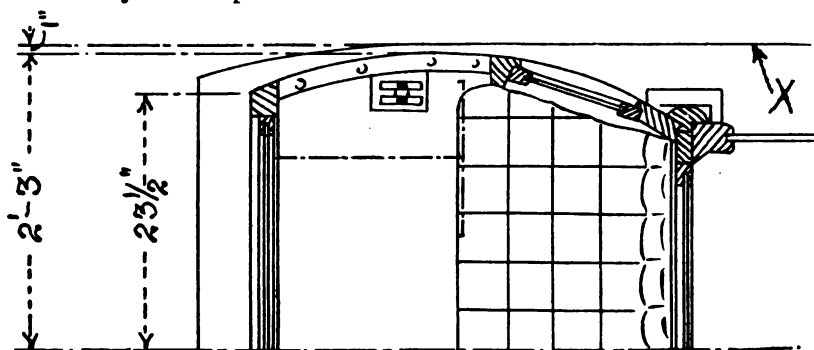

FIG. 3.—FRONT VIEW OF CAB SHOWING HOW LINES BLEND WITH BODY

plates, 2½ by ¾-inch, placed sideways. The trimming was leather. The glass windows at the rear of the driver's seat, as shown in the sectional view, are 10 inches high and extend the full width of the seat. It was thought that the tables would be too high but they are but 42½ inches from the ground at the rear, which is slightly more than the standard dimensions. The cost of the construction effected a big saving to the customer when compared with what a new design would cost. In addition, he has a very attractive body, one out of the ordinary. The accompanying sketches give the various dimensions, also a scale for feet and inches, and the data should prove of value to other designers figuring on similar work.



SECTION AT C. D.  
FIG. 2.—SHOWING HOW DRIVER'S CAB WAS CONSTRUCTED

# TIMELY TALKS WITH OUR SUBSCRIBERS



The American Blacksmith is published monthly at The New Sidway Building, Buffalo, N. Y., U. S. A., by The American Blacksmith Company, Incorporated under New York State Laws. Entered, February 12, 1902, as second-class mail matter at Buffalo, N. Y., Act of Congress, March 3, 1879.

William F. Wendt, President

Albert W. Bayard, Secretary

Walter O. Bernhardt, Editor

Associates: James Cran

Bert Hillyer

A. C. Gough

Dr. Jack Seiter

Subscription Price: \$1.00 per year in advance, prepaid to any postoffice in United States or Mexico. To Canada, \$1.25; other countries, 6 shillings. Reduced rates to clubs of five or more on application. See "Honor Roll" page for money-saving, long-time rates. Cable address, "Blacksmith," Buffalo. Lieber's Code used.

Subscribers should notify us promptly of non-receipt of paper or change of address. In the latter case it is necessary that you give us both the old and the new address.

## THAT BUSINESS LIBRARY.

How is your collection of business books progressing? Have you a complete collection of catalogues, bulletins, price-lists, circulars and advertising literature on smith-shop equipment, tools and machines? You can, of course, run your business without these helps, also a man can reach the top of a twenty-story building without using the elevator, but the elevator will make the trip to the top much easier, while a collection of business books, catalogues, price-lists and the like, will make smith-shop operation easier and more efficient.

The advertisers of today are offering catalogues, booklets and advertising literature that treat on subjects ranging all the way from automobile repairing to zinc welding. Booklets on horseshoeing, the treatment of horse diseases, the selection of coal and the care of the forge fire, tire repairing and an almost unlimited number of subjects in which the practical blacksmith is interested, are offered by progressive advertisers. And when these booklets, catalogues and other advertising literature can be secured at little or no cost, the practical craftsman has no excuse for not making up a collection of modern advertising literature touching upon his trade.

Look through this issue of "Our Journal" and write to those advertisers offering catalogues and other advertising literature which you have not yet added to your collection. Keep this literature on hand; you will find it full of practical suggestions and money saving ideas. You cannot do business efficiently and profitably without a collection of modern business literature treating on your line of work.

### Subscription Agents

When a stranger solicits your subscription to THE AMERICAN BLACKSMITH or any other publication, insist upon him showing you absolute proof that he is an agent in good standing and is employed by the publication which he represents. Don't, under any circumstances, give the man your money if you are not sure that he really works for the paper he says he does. No matter what the man offers you—no matter what price he makes—no matter what premium he promises to send—Don't Give Him Your Money If You Are Not Sure.

## Contents, December—1916

The Fable of the Smith Shop Owner and the Christmas Masama—Frontispiece .....	54
A Modern Blacksmith Shop and Garage .....	55
The Penalty for Speaking Falsely of a Business Man .....	56
A Chart for Quick Pulley Calculations	58
Contraction of Sheet Metal When Oxy-Acetylene Welded .....	58
The Federal Trade Commission and Cost Accounting .....	59
Notes on the Theory and Practice of Hardening .....	59
How to File Hand Saws .....	61
Eighteenth Century Wrought Iron Gate .....	62
An Old Problem: Setting an Axle Properly .....	62
Lameness and Shoeing .....	62
Thoughts on Timely Topics.....	64
The Smith In the Daily News.....	65
Blacksmiths Guests at Banquet....	65
Fellow Workers Honor Blacksmith Foreman .....	65
Thomas J. Farnsworth Blacksmith. To Make Smith Shop Historic Museum .....	65
Philip Smith Dead — Emery Wheel Breaks .....	65
Blacksmith Fleeced of \$2,400.....	65
Assistant Foreman First Apprentice Blacksmith Prices Take Jump.....	65
Blacksmith Wants a Wife .....	65
The Spirit of Christmas .....	66
Heats, Sparks, Welds .....	68
Our Honor Roll .....	67
Fundamentals of Lathe Practice ....	68
Practical Pointers for the Automobile Painter .....	70
Melting Furnaces for the Amateur Founder .....	71
Gas Engine Operation Made Simple—3	72
Benton's Recipe Book .....	73
A Cement for Holding Tools.....	73
Hard Putty .....	73
To Temper a Plow Share.....	73
The Faker Has Scored Again.....	73
An Idea for Keeping Small Parts...	74
A Cement for Fire Bricks .....	74
An Aluminum Cleaning hint.....	74
A Paint Remover .....	74
Queries, Answers, Notes .....	74
Our Journal In College.....	74
Balancing the Emery Wheel .....	74
Tempering, Welding and Forging...	74
Northeast Nebraska blacksmith and Wheelwright Price List.....	74
The Automobile Repairman.....	75
A Cracked Water Jacket.....	75
Causes of Noisy Engine Action....	75

## NEW IDEAS ON SHOEING.

The article on "Lameness and Shoeing," by Mr. A. L. Camp in this issue contains much food for thought for the practical horseshoer. Mr. Camp, as a breeder, trainer, racer and shoer of thirty-six years of experience, has studied his subject on a number of angles and brings to the reader a number of ideas that will surely set him to thinking along new lines.

It is only natural that some readers of THE AMERICAN BLACKSMITH will not agree with Mr. Camp's ideas, and we sincerely hope that those of "Our Folks" who are not in exact accord with the practices which Mr. Camp suggests, will let us have an explanation of their criticism of his methods, so that all may profit by full and open discussion of the very important subjects that are to be treated.

Mr. Camp's articles will continue for several months, and we know that they will be read with eagerness and interest by every practical horseshoer.

## SELL IT NOW.

The advances which have occurred in metals and materials during the past month, have of course caused an advance in the prices of old materials, metals and scrap. The advances which compel you to pay more for the material you use, will also enable you to get more for the materials you have discarded. Your scrap pile and that old pile of shoes is worth considerably more today than it was a year ago. If you have built up a column of old horseshoes in your yard or in front of your shop, better call in your scrap iron dealer, and ask him how much it is worth. Metal prices do not show any indication of a let-up in their steady rise, but we want "Our Folks" to sell their old scrap and their stock of old shoes, and be sure of a good price for them, rather than wait and take chances on a sudden drop in the metal market. There are hundreds of "horseshoe columns" throughout the country that are worth more right now as old material than they are as advertisements, and we cannot urge "Our Folks" too strongly to dispose of this old stock now when prices are good.



THE FABLE OF THE SMITH SHOP OWNER AND THE CHRISTMAS MAZUMA

There once dwelt in the Land of Plenty in the Village of Opportunity a Smith Shop Owner who became peeved over the fact that good, hard Simoleons were being diverted from the regular Channels of Trade onto the side track of "Gew-Gaw, Nick-Nack, Flim-Flam & Co., every Christmas-tide. When he mooned over the figures showing the probable expenditures of the millions of well-meaning but misguided Souls that graced the Land, he had another attack of Cerebral Stasis, and bit four dollars' worth of high-priced horseshoe nails in the head before he discovered his extravagance.

And so he became more peeved and less reconciled to the thought of the diversion of the country's loose change. Brow corrugation and scalp scarification took the place of "freeze-out" and "seven-up." Beal thought massaged the convolutions of his cerebrum. Yea, verily, and withal, howsoever,—the time for action was approaching as tho' mounted on an airplane. To resume—The time for action was already on the horizon. A "close-up" showed Our Hero, with brow-knitted and teeth set. The question mark was still branded upon his countenance. The great drama, "The Flaw in the Christmas Loot" still entertained his mind.

But one day he read of a hold-up in the streets of Chicago, and straight-way he sought out his trusty six-shooter, "Advertising." He sought his victim just as Old Nick was approaching the end of the car line, and at the point of his trusty Colt, he forced Old Father Xmas to do his bidding.

A visit to the shop of Our Hero disclosed to O. F. X. that Smith Shop Owners have a well-founded claim on the Circulating Medium of the Populace. "Christmas gifts can be useful as well as acceptable," said Our Hero. "The dispensers of canned opera are not one whit more suited to Christmas distribution than sleighs, buggies or cans of axle grease." "Yea, verily, and what more humanly represents the spirit of Christmas than a due bill for horseshoeing?" added Old Nick.

And so it came to pass that while in previous years the Yule-tide Smith Shop Business was afflicted with Anemia and predisposed to Rigor Mortis, it now flourished as the Banyan Tree, yea, verily, as the Dandelion, and great was the joy in the House of Smith.

MORAL: Go thou and do likewise.



## A Modern Blacksmith Shop and Garage

**O**VER in Dodge County Wisconsin, there are a couple of practical blacksmiths who have planned and erected a shop that is almost ideal for a general smithing, horseshoeing, woodworking and garage establishment. In fact, S. A. Holdridge & Son have called their establishment the "Ideal Garage & Machine Co."

This shop building, erected last year, is 36 by 70 feet in size, and is said to be the best equipped and most modern shop in Wisconsin State. The arrangements of departments as shown by the floor plan is excellent and permits of easy access to all departments. The door-ways leading from one department to another are all full size, 8 by 8 feet, thus permitting a wagon, carriage, buggy or automobile to be taken from one department to another without difficulty. It will also be noted that Messrs. Holdridge believe in plenty of light for their working force, as the numerous windows with benches and machines arranged accordingly, amply testify. They certainly realize that carrying on a business such as theirs, and doing such a large variety of work required an abundance of good light. Holdridge & Son, besides doing a general blacksmithing and horseshoeing business, also do woodwork and automobile repairing, they carry a line of tires, tubes and accessories, also doing vulcanizing and carry a general line of supplies. They also handle the Ford, Dodge and Grant cars, the Fairbanks-Morse line of gas and oil engines, the P. and O. line of farm implements and the Bull tractor. Mr. R. C. Holdridge says: "We have four men in the shop and manage to keep busy most of the time. We get 25c and 50c for shoeing, but on other work prices are poor. We hope that the blacksmiths will wake up pretty soon as most of the better educated smiths are gradually drifting into the automobile business."

This shop and floor plan of Holdridge & Son, and what they are doing proves beyond a doubt that the

practical blacksmith can add automobile repairing and the selling of automobile accessories to his other lines of work without injury to his regular blacksmithing trade. Very naturally, of course, a great deal depends upon the general smith's location, and also upon local conditions. S. A. Holdridge & Son are located in a very small town, but are drawing trade from distances which, in many instances, must surprise even them.

Before detailing the shop equipment, it may be well to call attention to a few matters which show how carefully the Holdridges have gone into the smaller details of their equipment and shop arrangement. For example: The large outside doors of the shop, the two in front and the one on the south side, are all 8 by 8 feet in size, with windows of liberal size in the doors. The two anvils, one of 260 pounds and the other of 160 pounds, are both mounted on concrete anvil blocks which certainly goes far toward improving the appearance of the blacksmith shop. The rivet rack and also the bolt rack are of generous capacity. The bolt rack alone permitting the storing of 30,000 bolts. The sills and frames of the windows on the horseshoeing side of the shop,

are lined on the inside with galvanized iron to protect them from horses who are inclined to chew and gnaw on the woodwork while waiting to be shod. It will also be noticed that there are six windows on the shoeing side of the shop, besides two large double doors.

In the wood shop there are five windows in all, while the various racks and groups of shelving permit of the storing of all manner of stock in convenient and well arranged order. The stock room is also well lighted by means of six windows, and here also the stock is arranged in orderly fashion, with stalls for the various sizes of iron and steel, each size having a stall by itself. The office is exceptionally well located, being very well lighted from the outside by means of two windows on the front, while the windows on the shop side of the office permit the occupants of the office to see into practically any corner of the shop.

On the garage side of the building is located the six-horse power gas engine, which beside operating all of the power machines, also operates an air compressor. This latter with its tank is almost a necessity in the modern garage as it saves a great deal of hard work. Another excellent time and labor saver in this

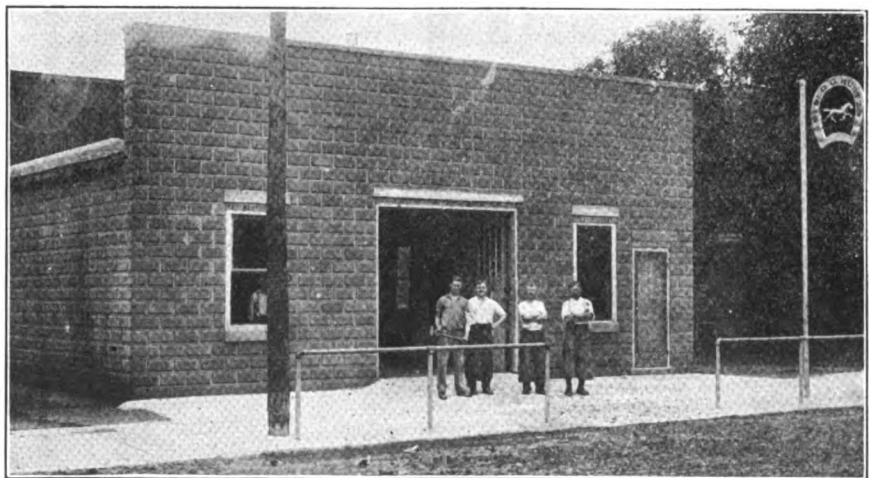

THE GENERAL SHOP OF MR. FRED G. KURTZ, OF MICHIGAN, IS A MODERN WELL-EQUIPPED ESTABLISHMENT. THE SHOEING FLOOR ACCOMODATES 26 HORSES AND THERE IS A VETERINARY OFFICE IN CONNECTION.





department is the power hack saw. On this side of the shop, it will also be noted, is a space for the display of the gas engine and other machines and supplies. A fire extinguisher is also included in the equipment of the garage. A large wash sink, located on the garage side of the stock room wall, is said by Mr. Holdridge to be the handiest piece of equipment in the shop. As may be noted from the photograph of the building, a gasoline pump is located immediately in front of the office windows.

Readers of The American Blacksmith will find a great deal of value and interest to them in the description and lay out of the Holdridge shop, and we know that those of our

readers who are expecting to go into the automobile business will find a good many suggestions and excellent hints in this shop layout.

### Blacksmith Shop

1. 50-lb. Trip Hammer,
2. Tire Shrinker,
3. Anvil 260 lbs. Mounted on Concrete Anvil Block,
4. Heavy Cast Iron Forge on Legs—Royal H Blower,
5. Rivet Rack most Complete in State,
6. Tool Bench,
7. Slack Tub,
8. Chimney,
9. Tool Bench,
10. Slack Tub,
11. 160 lb. Anvil Mounted on Concrete Anvil Block.
12. Heavy Cast Iron Forge Mounted on Legs—Royal H Blower,
13. Chimney,
14. Machinists Vise,

15. Bolt Rack Cap. 30,000 Bolts,
16. Outside Door 8x8 With Windows,
17. Iron Shears,
18. Front Door 8x8 with Windows in Doors,

Window frames lined inside with galvanized iron so horse cannot chew them.

### Wood Shop

19. Woodworking Bench and Tools,
20. Overhead Stock Rack for Spokes, Bolsters, etc.,
21. Wheel Horse,
22. Rack for Felloes both Wagon and Buggy,
23. Chimney Built so it can be used from both rooms,
24. Power Grind Stone, 6 ft. x 6 in.
25. Wagon Poles Hung up Lengthwise,
26. Shelves For Tire Bolts, Wedges, etc.,
27. Wagon Reaches and Shaves Hung up,

Outside windows 5 in all.

### Stock Room

28. Stalls for Iron & Steel—Each size has a Stall.
29. Bench and Overhead Shelf for Paint,
30. Oil and Grease Barrels,
31. Other stock such as Plows and odds and ends carried in this room, also tire bender and hand grindstone.

### Office

32. Desk,
  33. Chair,
  34. Windows from Office to Shop, can look in Shop anywhere from Office.
  35. Door from Office to Shop with Glass in,
  36. Shelves for Auto Supplies,
- Large outside windows in office give plenty of light.

### Garage

37. Machinists Work Bench and Tools,
  38. Stock Rack,
  39. 6-Horse Power Gas Engine,
  40. Drill Press, Cap. up to 1½-inch Drill,
  41. Air Compressor and Tank,
  42. Power Hack Saw,
  43. Hand Drill Press, also for Power,
  44. Punch Press,
  45. Space for Display of Gas Engines, etc.,
  46. Pyrene Fire Extinguisher,
  47. Wash Sink,
  48. Gasoline Pump,
- Outside windows 7 in all,  
Line Shaft runs length wise directly over machinery.

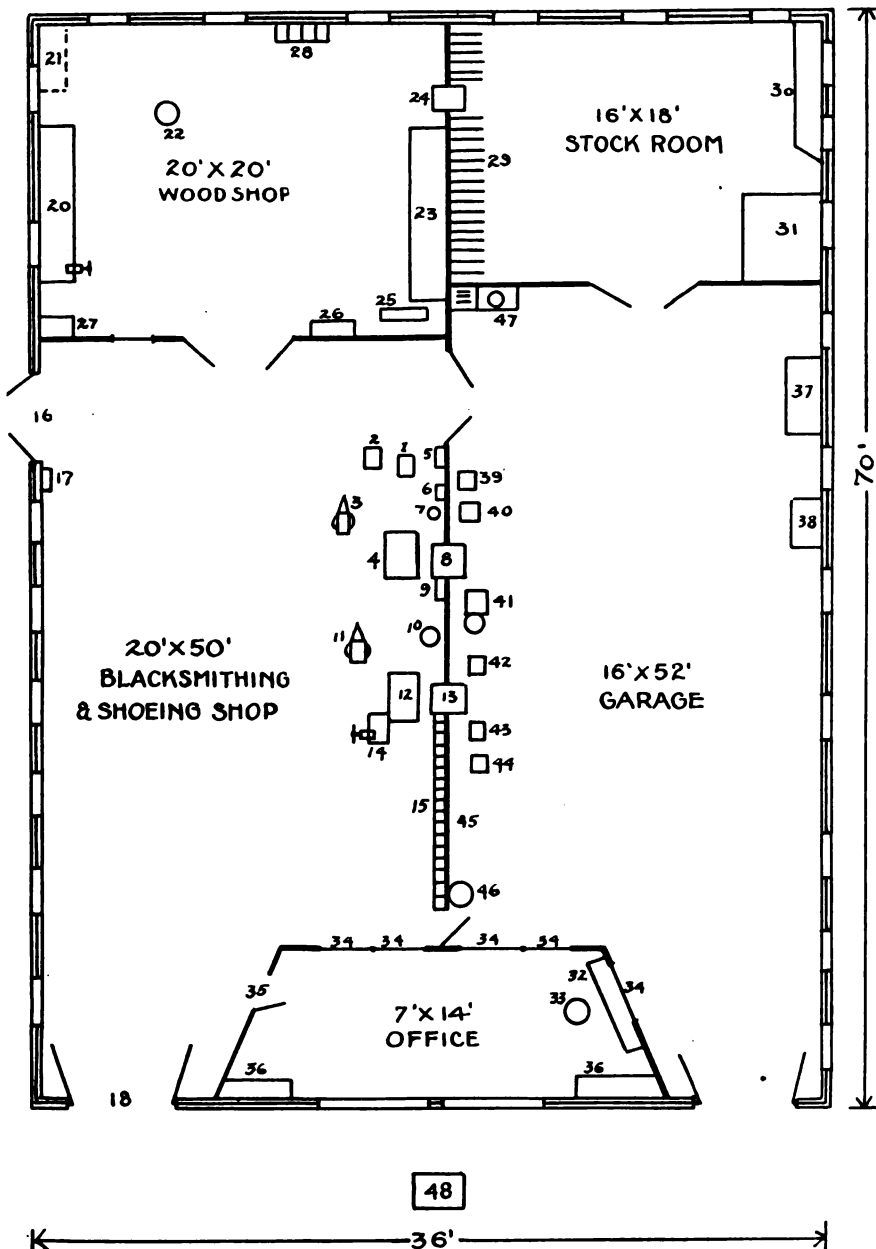

THE HOLDRIDGE SHOP SHOWING GENERAL ARRANGEMENT OF DEPARTMENTS AND MACHINES

## The Penalty for Speaking Falsely of a Business Man

I have received the following from a Western reader:—

I have read in magazines, from time to time, of the penalties for various legal offenses, but have never had the pleasure of reading what the penalty is, or should be, if one man should knowingly send out a false statement that would have a tendency to destroy the credit of another. For instance, I know a blacksmith in a country town who is a master of his profession, has a shop that is a credit to the town—in fact, the best shop the town has ever had. His shop is paid for and he discounts all his bills. Now if, knowing the facts as I do, I should publish the story that this man carries no stock, does not always pay his bills promptly and is only a practical workman, what is the penalty for such an offense, or what should it be? Are there



any United States Supreme Court decisions applicable to such a case, or what is the law pertaining to such an offense?

The correspondent seems to have an idea that the offense he speaks of is in itself a criminal offense, separate and distinct from other libels. That is not the fact. Aspersing the credit of a solvent merchant, or his ability as a master of his craft is a civil offense, and it may even be a criminal offense, but it is merely one of the class of punishable libels or slanders.

There are three aspects of such an offense.

1—The criminal libel (or slander) aspect.

2—The civil libel (or slander) aspect.

3—Misuse of the United States mails.

Such an offense could offend against the law in all three respects. If it offends against the first and third it would be punishable with fine or imprisonment; if it offends against the second it would be penalized by the payment of damages.

If the defamatory statement is written, it is libel; if spoken only, it is slander.

Consider No. 1. I question very much whether the language which this correspondent sets forth would be criminal libel at all. A man may be guilty of criminal libel though he speaks only the truth. The theory is that criminal libel tends to a breach of the peace, and it is therefore immaterial whether the thing said is true or not. But even if false it must be something pretty strong—stronger than this, in my judgment.

As to No. 2, this might or might not be misuse of the mails, and a criminal offense under the United States laws. Sending through the mails any matter which is "libelous, scurrilous, defamatory threatening, or calculated in any way to reflect injuriously upon the character or conduct of another," is misuse of the mails. But the matter must be exposed to the public gaze. If it is sealed inside of an envelope or a wrapper, it makes no difference how libelous it is, it is not misuse of the mails and the postal authorities will take no notice of it.

If this correspondent wrote the above on a postal card, he might or might not be guilty of misuse of the mails. I say he might not, because this language is a little weak for a criminal offense, in my judgment.

What this offense really is, is trade libel, a civil offense only. The

law is pretty uniform about trade libel throughout the United States. Words which when spoken or written of an ordinary individual might not be slander or libel at all, would at once become so if spoken of a man in connection with his business, trade, profession or calling. A good definition of trade libel is—"any words spoken or written of a person in his office, trade, profession, business or means of getting a livelihood, which tend to expose him to the hazard of losing his office or position, or which charge him with

a poor, one-horse merchant *besides* not paying his debts, you paint a picture of slackness, inefficiency, and poor credit, which any court would almost certainly call a trade libel. Always provided, of course, that it was untrue. If true, it is not a civil libel at all.

If the court held it to be a trade libel, it would allow damages even though no actual damages were suffered. The libel law knows two sorts of damages, general and special damages. Special damages are actual damages—those which do not



THE KURTZ SHOP IS EQUIPPED WITH ELECTRIC POWER AND HAS A MODERN GAS TIRE-HEATER. MR. F. G. KURTZ AND HIS THREE BROTHERS RUN THE BUSINESS

fraud, indirect dealings, or incapacity." Such statements can be sued for even if no damage has occurred, because they tend to injure him in his trade, profession or business. In other words, the charge must be such that if true, would render him less qualified to carry on his business.

The law is especially tender with the reputations which men have won in business and will sharply punish anybody who destroys or injures them. To falsely say that a business man is in financial difficulties, or is dishonest, or a fraud, or has been guilty of any other practice which, if true, would make him a poorer manufacturer, merchant, clerk or artisan than he would otherwise be, is to be guilty of trade libel.

There is a case which holds that it is not a trade libel to say that a merchant does not pay his debts, because even if he didn't he could still be a first-class merchant so far as the public was concerned. But where you run him down generally—say that he has a poor shop or store, doesn't keep a stock, and in fact, is

necessarily follow from libel, but which may follow. If they have followed, no matter what the circumstances, they can be collected. An example would be where one merchant, speaking of a competitor, said to one of the latter's customers, "he is notorious in the trade for the shoddy goods he sells," and the customer, believing it, took his trade away. In many cases no damages except those which have actually happened, such as the above, or the loss of a position or of a contract, can be collected. If no damages can be proven, none can be collected.

But in trade libels it is not necessary to prove special (actual) damages; the law allows what it calls "general damages." General damages are those which the law holds *necessarily* follow from the speaking or writing of the false words about business men. In other words, if I say to a jobber, speaking of a retailer, "I consider him financially weak," the law considers that I have inevitably done that man some injury—that I have in part destroyed



the good opinion which the jobber had of him, even if the jobber did not take any business notice of what I said. Therefore, because there is this inevitable injury, which cannot be estimated in money, the jury which tries such a case will be allowed to give the plaintiff such a sum as it thinks will make him feel good again. This is the sort of damages which can be recovered in actions for trade libels.

(Copyright by Elton J. Buckley.)

### A Chart for Quick Pulley Calculations

W. F. SCHAPHORST

The accompanying chart does away with formulas for making pulley calculations. It will be found to be exceedingly quick and extremely simple.

For example: Suppose a motor is running 1,200 r. p. m., and is to be used to drive a line shaft at 300 r. p. m. What sizes must the pulleys be? On the slip of paper in position A on the chart, make marks opposite the 300 and the 1,200 as shown; now slide the paper up to where you want it. Position B shows that the pulleys, 15 inches and 60 inches in diameter, respectively, will do the work very well. Of course, if these diameters are considered too large, just shove the paper up a little higher, and choose the best diameters for your particular purpose. No matter where the slip is placed, the ratio is always correct—no figuring is necessary.

This chart also lends itself readily to the solution of such problems as—knowing the pulley diameters, and knowing the speed of one of the pulleys. What is the speed of the other pulley? For example: Suppose we have a line shaft pulley operating at 200 r. p. m. The pulley on this shaft is 15 inches in diameter, a counter shaft pulley is 12 inches in diameter. The problem is, what is the speed of the counter shaft pulley? In using the chart, we mark our paper at 15 inches and at 12 inches, move our slip of paper down on the chart until the mark at 12 is in line with the mark at 200 on the chart, and we find that the mark at 15 indicates that the speed of our counter shaft pulley is 150 r. p. m.

Now, supposing we want this counter shaft pulley traveling at 250 r. p. m., with a diameter of 12 inches, to operate a machine pulley of eight inches—what will be the speed of the machine pulley? As we did in the previous example, we make

marks on a sheet of paper at 8 and 12 on the chart, move our paper down until the 8 mark corresponds with 250 on the chart, and we find that the 12 mark indicates that the speed of the machine pulley will be 375 r. p. m.

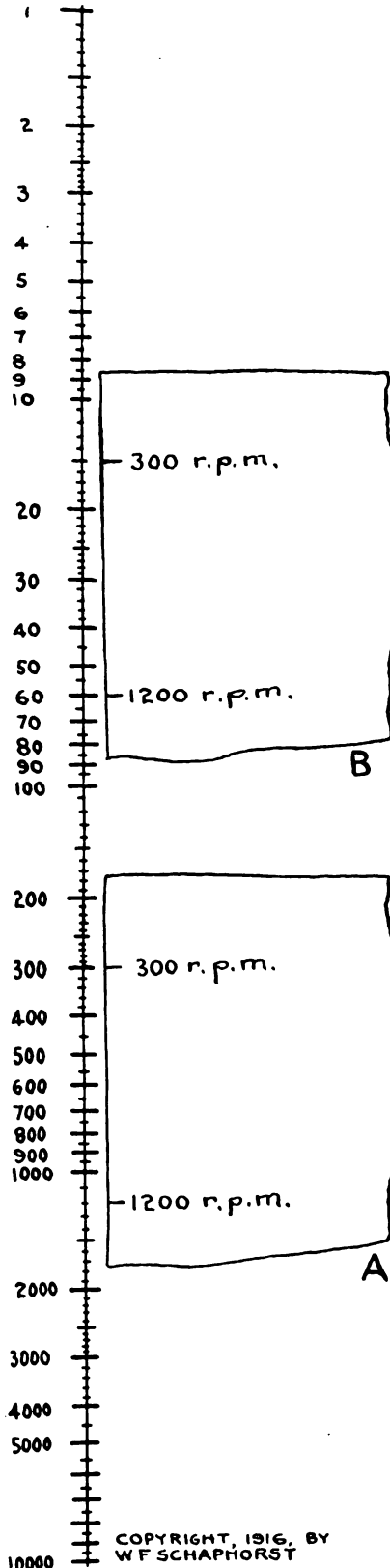

COPYRIGHT, 1916, BY W.F. SCHAPHORST  
THIS CHART SIMPLIFIES PULLEY CALCULATIONS

Now, supposing that we have a 12-inch counter shaft pulley traveling at 250 r. p. m., and desire our machine pulley to travel at 300 r. p. m., what must be the size of our machine pulley? We again take our slip of paper, mark on it at 250 and 300 as per the chart, move it up on the chart until the 300 mark corresponds with 12, and we find that the 250 mark indicates that our machine pulley must be about 10 inches in size.

Now, suppose we take another example, supposing that we have received a new machine with a ten-inch pulley, which has to travel at a speed of 300 r. p. m., and our shaft speed is 200 r. p. m. The question is—what size must the shaft pulley be? We again take a slip of paper, making marks at 200 and 300 as per the chart, move the slip up until the 200 mark corresponds to 10 on the chart, and find that the 300 mark indicates that the size of the shaft pulley must be 15 inches.

This chart will save the practical smith and power-shop owner considerable time and trouble in figuring what to some craftsmen is a complicated calculation—the sizes and speed of shafts and pulleys.

### Contraction of Sheet Metal When Oxy-Acetylene Welded

BERT HILLIER

The writer has noted several well-written articles on oxy-acetylene welding of cast iron, however, little has been said about sheet steel as this metal is not liable to crack, and inexperienced people think all there is to it is to lay it together and weld it. The two sheets, B and C, in the engraving, show the results of being welded this way. Sheets carelessly welded either overlap or buckle. That an opening must be left in one end to allow for contraction has been proven by experience. The writer has talked to different welders on the subject, but none agree on the exact amount to be left open to the foot. This difference in opinion, the writer thinks, is because some welders are faster than others. In the slow welders case, the metal gets cold and contracts right back of his weld. This keeps pinching and upsetting the soft, hot part together and he requires more opening than the fast welder, who covers a large space before the iron fully sets. What helped to convince the writer of this was the work of an apprentice.



He had welded sheets together to make a tank, 9 by 9 feet by 16 inches, sides of metal  $\frac{3}{8}$ -inch thick. This welder was very good from the short experience he had when he first started to weld these tanks, but as he became more adept and did faster work, the space allowed between sheets was cut down fully a  $\frac{1}{2}$ -inch less than when he first started. The figures shown on the piece in the engraving at A, shows from what distances the openings closed together while being welded. It is seen, as the length is increased, the

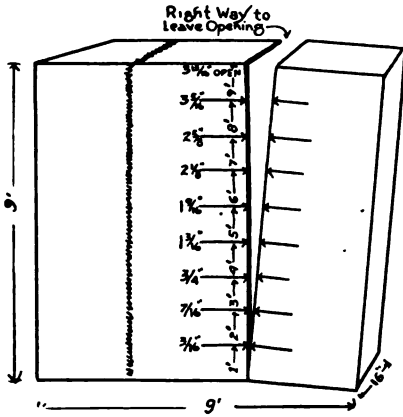

HOW THE PIECES SHOULD BE SPACED

space where it closes runs a little irregular to the foot, due probably to a stop made in the welding to recharge the generator, which allowed the metal to cool off completely. The figures shown are for loose welding, not clamped welding, as the latter requires less open space.

### The Federal Trade Commission and Cost Accounting.

From an address by Edward N. Hurley, Chairman of the Federal Trade Commission.

The Federal Trade Commission is doing all it can to help in the matter of cost accounting. In the first place, they have prepared two pamphlets giving plainly and briefly the fundamentals of cost accounting, one for manufacturers and one for merchants, and thousands of requests are coming in for these pamphlets.

In the second place, the Commission is co-operating with many trade associations which are endeavoring to get their members to adopt sound accounting systems. They send our experts to meet with them and discuss the features of cost accounting that are peculiar to the particular industry. They tell them to work out a system of cost keeping. When they bring it in, the Commission will

counsel with them and will approve it as a basic system for that industry. With this general standard officially approved, details to vary, of course, with the individual companies, the association has a strong argument to bring its members into line with sound accounting.

The banker has an interest in every movement that makes for the welfare of American business and the general prosperity of the public, for that welfare and that prosperity constitute the security for loans. But he also has a public responsibility, for the wise and healthful distribution of capital among the enterprises of the country. It is his interest and is a part of his responsibility to do his share toward bringing about better knowledge of business costs and higher efficiency in business.

Suppose three business men come to a bank for loans. Smith lays down his cost sheets. They are detailed and clean cut; he explains some recent economies they have taught him. He shows his balance sheet. He has a carefully considered depreciation charge. He shows just what that business is worth, and the bank knows he is right. Brown's cost sheets are very general. They don't give him a real analysis. He doesn't carry any depreciation charge; but guesses he ought to and says that when a good business year comes along he will write off four or five thousand dollars. Then Jones comes in. He says he hasn't any cost system; it costs more than it's worth; besides he knows what his goods cost him, carries it in his head. When the banker speaks of depreciation, he asks, "What's that?"

Now, what is the banker going to do with these three types? The Smith type, of course, gets his loan. But what is the banker's duty to Brown and to Jones? If he gives them a loan, don't you think he ought to condition it upon the establishment of an accounting system that will show their real costs and their real financial conditions?

The banker ought to do this not simply for their sakes and to protect his loan to them, but to protect his loan to the man who is sound and to protect business as a whole. For the man who does not know his true costs is just the man who *prices his goods foolishly*, and thereby impairs the business of his sound competitors at the same time that he ruins his own. Too low price-making, based on guesswork or on

partial costs is a menace to sound business. The menace is not in *underselling*, for a business concern must expect to face the low prices that are due to efficiency. But even the most efficient concern may not be able to meet cutthroat prices based on ignorance.

### Notes on the Theory and Practice of Hardening

T. WEST

#### Hammer-Heads

A hammer-head affords an illustration of a different kind of those we have previously considered, as it requires both ends to be of a much harder temper than the middle. I will describe two methods

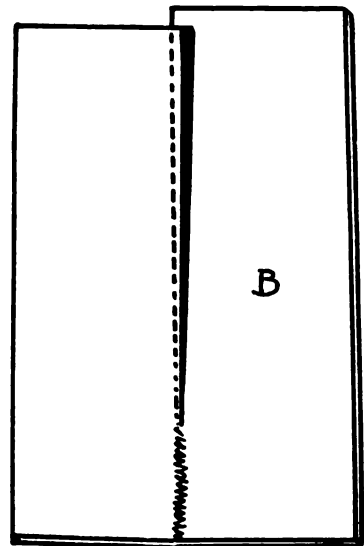

Welds Started Here

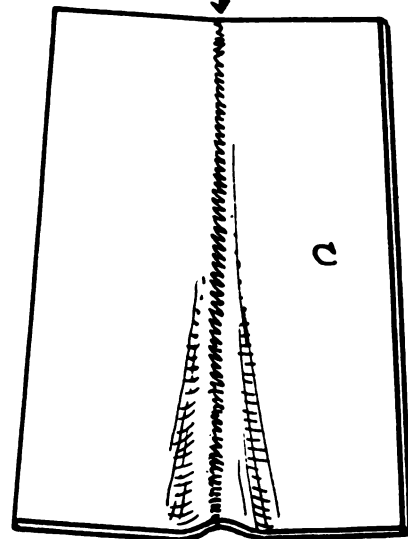

WHAT HAPPENS WHEN SHEETS ARE NOT PROPERLY SPACED

of attaining this object. I give the first method because it furnishes an illustration of the use of clay for protecting a portion of an article required to be left soft, and as this happens sometimes with



articles where it is the only means possible of achieving that object, it may help a worker in devising a plan for hardening something that otherwise he may be at a loss for means of doing; but the second method given is the most practicable.

By the first method, the middle, or eye, portion is not hardened in quenching, and by the second method the middle is hardened; but the temper is afterwards drawn very much softer than the pene and face. To prevent the eye and middle of the hammer from hardening, a clay is used that will bake without crumbling. The eye is filled with this, and as much of the

middle of the hammer as is required not to harden is covered thickly with the clay. As the contact of water with red-hot clay has a tendency to cause it to crack to pieces, fine iron wire should first be wound round the middle of the hammer so loosely that the clay can be kneaded between it and the hammer, which will retain most of the clay in place, even when cracked. The whole must now be placed where it will dry, as to plunge moist clay in the molten bath would cause accidents both to the worker and the work. Handy to the forge fire, but not near enough to cause the clay to

steam, is a good place to dry the clay.

When the clay is quite hard the molten bath should be prepared as before described, and the hammer-head covered with lampblack or paste, and immersed in it as soon as the bath is melted, a test-rod of the same steel being also inserted. When a redness appears the test-rod should be quenched, and if it does not harden the heat of the bath must be raised a little, and another trial made with the test-rod. When the test-rod hardens on quenching, the hammer-head should at once be quenched, plunging it into the water perpendicularly. A convenient way to hold

*Berleger's Improved Patent Gearing for Carriages.—Patented February 3, 1852.*

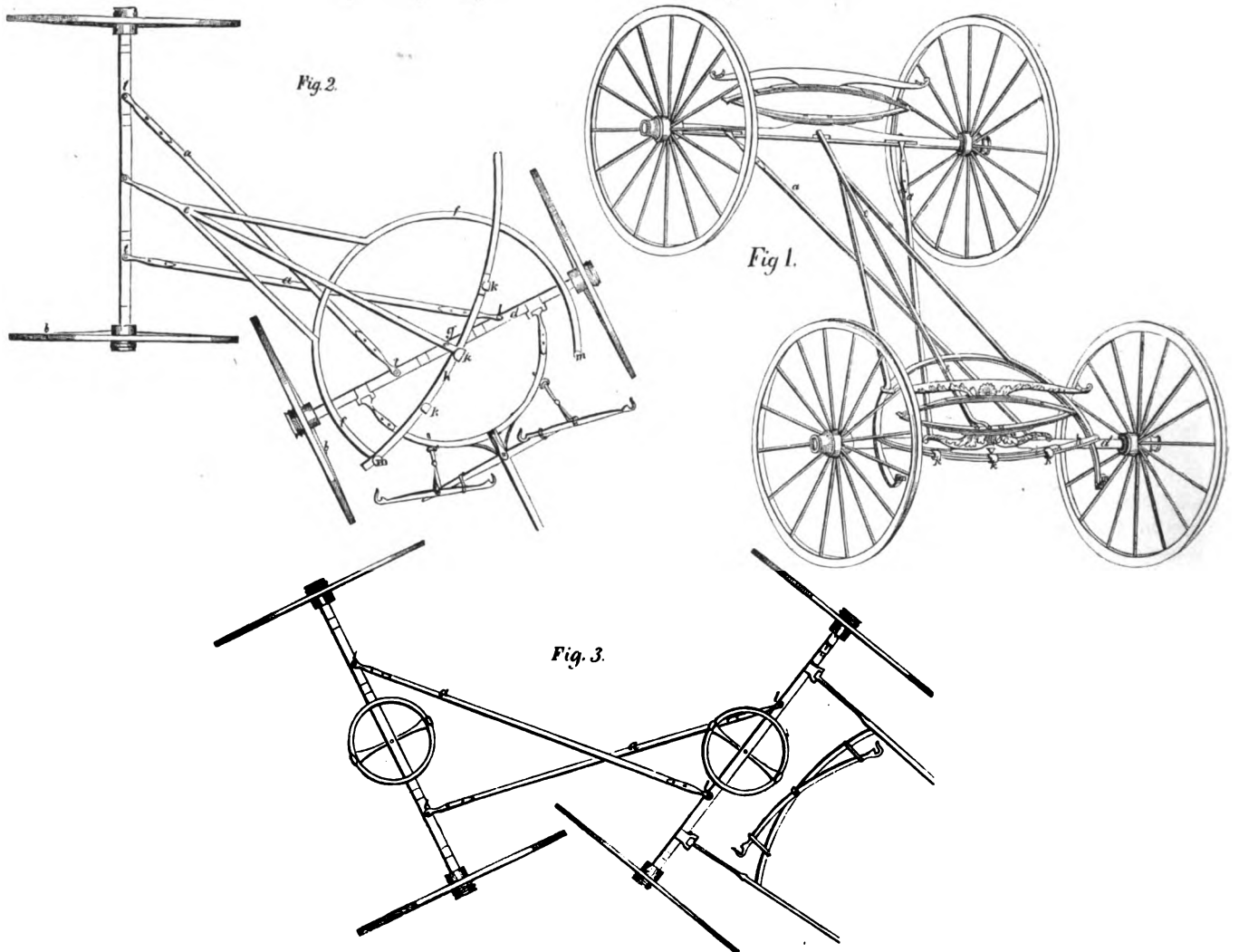

THE COACH BUILDERS MAGAZINE PUBLISHED THESE ENGRAVINGS IN 1852 OF A "NEWLY PATENTED IMPROVED CARRIAGE GEARING"

the hammer when quenching is to twist a piece of stoutish iron wire round one end, leaving a length to form a handle. This should be done before putting in the clay, and if a loop is made at the end it will serve to hang the head up by whilst clay is drying. I should have given the caution that the clay must taper off towards the face and pane, as, if too thick there, it may produce too defined a line of heat, and so cause a fracture there, which may develop in use of the tool. As soon as the head is cold, it should be immersed in boiling water for, if allowed to remain cold when dead hard just after quenching, internal strains may cause minute fractures to commence, which would get larger

later on, and break the tool when in use. Half the broken hammers are owing to neglect of this precaution. Whilst the head is still very warm it should be brightened on a wheel or with a piece of emery or carborundum-cloth. The latter does this quickest on dead-hard steel, but for iron, soft steel, brass, or gunmetal, I have not found carborundum-cloth cut very much faster than emery cloth—which is strange, as the carborundum-wheels certainly cut faster on anything.

The temper-colour can now be got in the molten-tin bath (see table of temper-colours), the hammer being inserted as soon as the tin melts, and the heat raised slowly to permit it reaching equally all

parts of the hammer, which should be repeatedly withdrawn, and the colour produced examined. If a hot-oil bath is used, the thermometer must be watched, and the head withdrawn when the required degree is reached, and cooled in water.

Personally, I prefer the method which I now describe as it is less troublesome, quicker, and, in my opinion, produces a stronger hammer. Proceed just as before directed, omitting the clay covering, and when the hammer is dead hard put it in boiling water, and then brighten as before. To temper it, the creeping method is particularly suitable to the conditions required in this tool, as the hardest portions are never ground away as in a



cutting tool, and the very hardest parts are just where they are needed, gradually becoming softer as they are farther away, which gives hardness and strength exactly where they are required.

Prepare three or four iron bars that will fit the eye of the hammer as nearly as may be. Get these red-hot, and leave in the fire until each is required. Insert one in the eye of the hammer, keeping the face uppermost, and the pene just in the water. Watch the color on the face, and when the desired shade, turn the hammer round so that the face is now in the water and the pene uppermost. Watch the colour on the pene as before, and, as soon as it is of the shade required, plunge the whole head into the water. As the heat in one red-hot bar will be insufficient to raise the necessary tempering temperature, it must be changed for another bar from the fire as soon as it gets a very dull red, and if the hammer is large the heat of several bars will be needed.

The temper of the eye of the hammer should be of a colour nearly black, and if this colour has not come during the tempering of the face and pene, a further heating will be needed. Put the iron bars

in the bottom of the tank—and to fill such a tank one must pour water through an inch pipe. Of course, if the bar cools to a dull red before the required colour comes, other heated bars must be inserted until the colour-temper is produced.

I am drawing particular attention to this fact now, as the specific conductivity of steel is a factor in accomplishing the object where a hard temper is required very close to a much softer temper. These conditions occur frequently in tools subject to strain or to shock. This combination can only be achieved by keeping cool the hard temper whilst heat is very rapidly supplied to produce the softer temper. I have already employed this principle in the description of a method of retempering pocket-knife blades; but as these papers are written in the hope that they may give some instruction in the principles of hardening, rather than merely describe empirically certain operations in the art, I wish to emphasize the fact of specific conduction playing a part by again drawing attention to it and the principle underlying it. Perhaps, I may make it a little clearer by reminding readers of how much more difficult it is to get

It does not necessarily require any great skill, as many people suppose, to file and set their Saws, but there are a few essential points which should be observed if you wish to get the best results. These observations are based on long experience and careful study, and it is earnestly hoped will prove of benefit.

The first operation should be what is commonly called joining. It is better to take a flat mill file and rub the teeth down until their length is uniform. For instance, in a straight-breasted Saw, if you should put a straight edge along the teeth, every one should just touch it. Then comes the setting. Use, if you have one, a regular setting block, and care should be used in preparing said block not to have a sharp edge where the tooth bends down, as it is apt to cause breakage. Do not set your tooth too far into the Saw. A turning of the point is sufficient and far better for the Saws. The teeth should be set alternately right and left. A highly tempered Saw, which will hold the edge best, must be carefully handled or you will lose many teeth in this operation. Do not put any more set than just enough to clean nicely.

Your Saw is now ready to file, and you will find it advisable to select your files carefully. For a six and seven-point Saw use a 7-inch slim taper. For eight and nine points use 6-inch slim taper, and for ten, eleven and twelve points use a 5-inch slim taper. After placing your Saw securely in the vise, commence to file at the point and progress toward the butt or heel. Many skilled filers, however, file from the butt to point. Always file the teeth which are set away from you, and as to the amount of beveling, it is entirely at the discretion of the carpenter. It is essential, however, that the bevel be placed on the front of the tooth. When through with one side, reverse the Saw and proceed as before. At this point it might be well to use the flat mill file, and do what is commonly called side filing the teeth. This is to guard against any uneven setting, and will be appreciated in the finished Saw.

To prepare rip Saws proceed as in hand Saws, except always use 7-inch slim taper, and if the Saw is intended to cut hard lumber a slight bevel is advisable, but if for ordinary and soft wood it is best to file straight across.

To insure a keen, sharp cutting edge to your Saw, it is well to pass

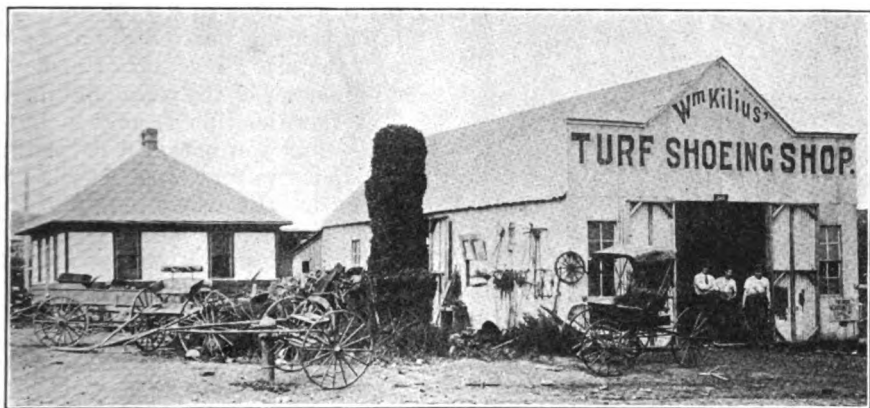

THE SHOERING AND GENERAL SHOP OF MR. WILLIAM KILIUS IN OKLAHOMA

in the fire and make them nearly white-hot. Previously to heating the bars, a piece of hoop-iron should be bent to the shape of the letter E without the middle line; this must just clip the ends of the hammer. With this clip fix a wad of cotton-waste on each end of the hammer, and wet it. These wads must be kept wet during the whole time the hammer-eye is being further tempered by being alternately dipped in the water. Insert the nearly white-hot bar in the eye, watch the colour on the side of the eye, and when it turns nearly black plunge the whole into the water. Be careful the cotton wads do not get dry or fall off until the operation is finished, or the high tempering-heat will run so quickly that the face and pene may be made softer than they should be. The reason for using the iron bars at a greater heat when tempering the eye is because conduction is carrying away the heat to the face and pene as rapidly as the specific conduction of steel will conduct heat, and this heat is being removed by the evaporation of the water on the cotton wads at both ends at once. Therefore, if heat is supplied to the eye at only the same rate as the specific conduction of steel will carry it away, the eye would never attain the temperature producing a black temper-colour. It would be like pouring water into a tank through a half-inch pipe when there was a half-inch hole

a head of solder to melt with the blow-pipe when soldering on a large piece of copper than when soldering a piece of brass, the specific conductivity of the copper being higher, and conducting the heat to the farther portions as fast nearly as the flame supplies it; and should there be another solder-joint near, that has to be kept cool by water, the blow-pipe has to be blown the stronger, so that the rate of conductivity may be exceeded by the rate at which heat is supplied; whereas the lower specific conductivity of brass, under exactly the same conditions, presents less difficulties—the analogy being that soldering copper is similar to tempering a soft portion close to a hard, and soldering brass is similar to tempering a soft portion some distance from a hard.

### How to File Hand Saws

From "Saw Sense", E. C. ATKINS & Co.

A subject of never-failing interest to the average worker in wood is the care of tools and how to sharpen them to the best advantage. That opinions differ as to the way the work should be done is not surprising, especially when the question of filing a Saw is considered.



a hard oil stone lightly over the sides of the teeth to take off all burr or wire edges left in filing.

With these points carefully in mind, we see no reason why you should not be a success in the care of your own Saws.

## Eighteenth Century Wrought Iron Gate

JOHN Y. DUNLOP

The gate which is one of the features in English wrought work is taken from York Minster which is notable for the extensive scale and grandeur on which it is built. The church itself was built in the fourteenth century but this gateway was originally of wood.

The present gates, which are at the entrance of the choir; were erected in the time of Dean Finch during the first quarter of the eighteenth century.

The ornamental part over the double gates originally was in two parts, with triangular sections at the meeting styles and opened with the gates. But after a time the upper parts were taken down and separated from the gates and fixed on to a horizontal bar which forms the lintel of the opening. The details of the upper portion are rather thin in parts but they are well executed.

The gates are very simple in design with their series of repeat ornament at each horizontal rail. In the center of the gate two horizontal rails form two panels on each side of the meeting styles which are filled in with a series of scrolls. The scrollwork is practically of a uniform section throughout and only at one function is the grouping relieved with leaf ornament.

At the sides of the gates, the side panels are of a nicely balanced design. The two horizontal rails marked A and B are at the same level as the middle rails in the gate while the space underneath that is filled in with two vertical rectangular bars.

This gate was probably made at a time when rolled iron was to be had in the English market for, on close examination, it would appear as if this modern work had suffered somewhat from the mingling of rolled and hammered iron. It is essential, if the whole effects of ornamental work is to be fine, that all the parts, the straight as well as the fine, should be forged; as the introduction of milled iron in the straight parts and its regular setting at once, gives a hard and mechanical appearance

even to a well designed piece of work.

## An Old Problem: Setting an Axle Properly

That the correct laying out and setting of an axle is an old problem, is attested by the following item and its accompanying engraving which appeared in Saladee's Coach-Maker's Magazine of January, 1855.

The following rule for setting an axle properly, and so as to have the spokes from the hub to the ground stand perpendicular, &c., may prove of some importance to many of your numerous patrons engaged in the

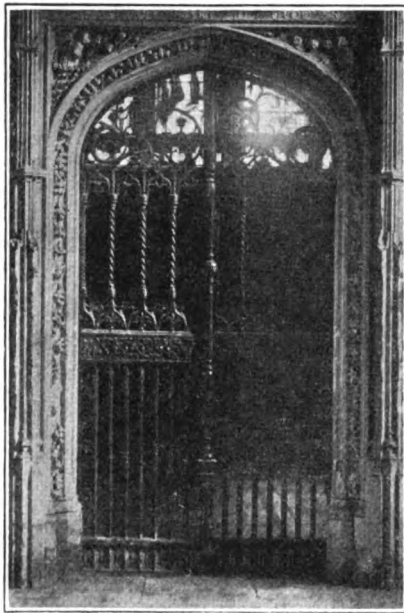

THE CHANCEL GATE IN ELY CATHEDRAL

business, and should you consider it worthy of notice, *give it a corner in your Magazine.*

"Explanation of the rule 1 represents the timber from which the axle is designed to be made, the bottom part of which is plained off straight, (if the axle is to be crooked, then a pattern is necessary, to which the rule is applied in the same manner as the straight one now under consideration,) then draw line 3 square across the side which is the back of the hub, from this, measure the length of the hub and make another square line as Fig. 9, then ascertain the distance from the back of the hub to the front of the spokes, or mortices of the spoke, and draw line, Fig. 5; this done, draw line 8 near about the centre of the axle. Having ascertained the semi-diameter of the wheel, you will measure that distance from the cross lines at Fig. 5 to Fig. 2 on line 8, and draw

another square line across the axle at this point, as shown in Fig. 2; the next step in order will be to ascertain the dish of the wheel you intend attaching to the axle, which mark from line 8 on line 2, and make a dot, then draw line 4 from the last dot made at fig. 2, so that it will intersect the cross lines at fig. 5, this line 4 you make the center of the arm or spindle, the size of which is obtained from this line at both butt and point, the space from line 5 to line 3 should be multiplied by 2 for both arms, and subtracted from the measurement of the track from outside to out, where the wheels bare on the ground, which will give you the desired distance from shoulder to shoulder. I will here define the meaning of each line drawn in the cut, which will assist the reader in readily comprehending it. Line 3, back of the hub; line 9, front of hub; 5, front of spokes; 6, the bottom or bearing part of the arm; 7, top of the arm; 4, center of arm; 2, semi-diameter of the wheel and dish; 8, the parallel line from which to work,—thus you obtain a perpendicular spoke to any sized wheel. No matter what the dish or length of the hub or size of the box or boxes in the hub, a desideratum not attainable by the old rule, or any rule that does not recognize dish of wheel, length of hub, &c. You will readily perceive, if you have a perpendicular spoke, that the space from the front of the spoke to the back of the hub, should be deducted from the width of the track, which will under all circumstances give you the correct distance between shoulders.

The above rule is also applicable to iron axles, by first making the draft upon a board accordingly.

J. M.

## Lameness and Shoeing

A. L. CAMP

I will endeavor to explain the ailments of the foot and leg of the horse, which we owe their existence directly or indirectly to the faults of shoeing, and will endeavor to suggest the mechanical adjustment of the feet and shoes for the avoidance, removal or alleviation of these ailments. I am fully aware that many of my ideas are in opposition to the accepted and practiced ones of today, but the unsatisfactory results of the present practices are evidence of their falsity, and may it not be that a contrary or different way will be attended with better results.

As my occupation for thirty-six

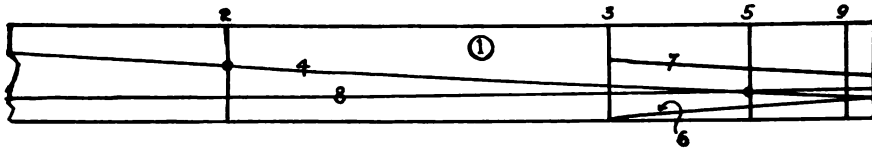

AN OLD PROBLEM: LAYING OUT A WOOD AXLE

years has been almost exclusively breeding, breaking, training, racing and shoeing, I feel that I have had a better and wider field in which to gather the fruits of experience, than has one whose lines have lain in narrower ways.

The foot of the horse has become, through aeons of evolution, a large weight bearing toe-nail, and must be considered as such if success would follow its treatment, for no comparison of it with the pad-soled and flexible feet of other types of quadrupeds or bipeds can apply. This consideration must eliminate from one's mind any ideas of heels and toes in their true sense, and when these terms are so applied by me to the foot of the horse let it be understood as a means of illustration only.

Although this horn-incased foot is apparently flexible, according to the common acceptance of the term, yet, strictly speaking, it is not so, for there are the motions of expansion and contraction as well as the malformation of the hoof's symmetry, that only too often follow on the heels of misdirected farriery. Expansion and contraction are natural and necessary for the foot's welfare when in unison. Either of them occurring without the other is abnormal and deleterious. Experiments by me have given the following results:

A natural foot when uplifted—bearing no weight—would be about 1/4 of an inch narrower at the bearing surface at the heels than when the animal is standing and each one of the four feet is bearing its quota of weight. When walking three feet are on the ground at one time; trotting and pacing, two feet, and when running, one foot. As expansion increases in proportion to the amount of pressure to which the foot is subjected it will be seen that with a lesser number of feet bearing at one time and further enhanced by the force of the blows when at speed the expansion of the foot increases very greatly. As the expansion is greater in a running horse, more care is necessary to have the course softened by a deeper cushion than is required for the slower gaits, because of the pain by the expansion from the mighty blows. I have seen

a runner's hoof split from sole to coronet on a hard track.

But as above stated this expansion is necessary and essential if in conjunction with contraction, for the welfare of the foot, for without it the concussion would crush the laminae or split the bones of the legs.

Considering the essentiality of expansion we may further consider the probable harm when the shoe is nailed as it is on the uplifted foot when contraction is at it's greatest. Unlike the feet of the pad-soled creatures whose soles are the direct weight bearers, that of the horse is not so in the sense generally accepted, for it's sole is not intended to rest upon the ground. This function is for the rim of the hoof-wall only, while the sole is suspended between the walls. It is concaved on it's un-

der surface, and forms a base for the pedal or coffin to rest upon it's convexed upper face. It is this concavity that expands and contracts the walls. Expanded when the weight is upon it, contracted when removed. This movement is greater at the heels and gradually decreases forward but is perceptable only to about half way of the foot's length although unquestionably it is exerted to the toe's point. This being so the minimum restriction of this movement would follow nailing the shoe forward as far as possible.

In a state of nature contraction never obtains and therefore no provision exists to offset it. But there is a governor to control undue expansion, viz: The frog. Contrary to general belief the frog's function is not to bear weight though it has two equally essential uses. It is a buffer to prevent the too great depression of the concaved sole, and the consequent abnormal expansion of the hoof and also acts as a cushion support to the flexor tendon upon which the navicular bone is suspended, and supported. This bone is the prime

DETAILS OF WROUGHT IRON CHANCEL GATE ELY CATHEDRAL ENGLAND



DETAIL OF UPPER VERTICAL BARS



MEETING STYLES

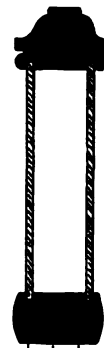

SECTION

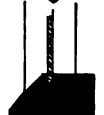
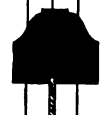

SECTION

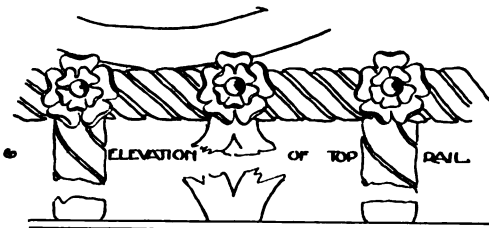

ELEVATION OF TOP RAIL



ELEVATION OF LOCK RAIL

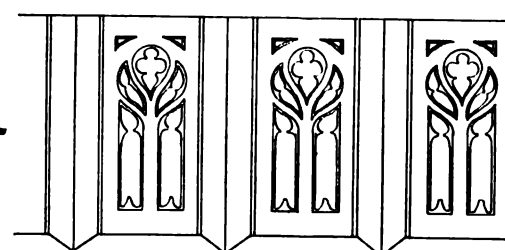

ELEVATION OF SOLE RAIL

PHOTOGRAPHIC ENGRAVING OF THIS GATE IS SHOWN ON PRECEDING PAGE





factor as a shock absorber, forming as it does one half the socket for the base of the short pastern bone, and supported as above described by the tendon, which in turn rests upon the frog.

At a later date, I hope to enlarge upon the nature and duties of these parts of the foot. The present mention that has been made of them has been to lead the mind of the reader to the characteristics of these components that I may better make clear the reasons for the suggestions to follow upon the preparation of the foot, and the application of the shoe, in a manner that will obviate the evil to as great extent as possible, that has so surely attended the practice of farriery because of the non-consideration of these components as individual organs, each having a separate and distinct function incapable of substitution and upon whose unrestricted actions the welfare of the whole depends.

Probably nine-tenths of all horses kept continuously shod are more or less sore in one or more feet. This does not mean that the workmanship of applying the shoes is altogether wrong, though I regret to say that much of it is so, but that the effects attending the continued wearing of rigid metal upon the growing hoof must necessarily be attended with restrictions to that growth and proper expansion and that such restriction results in evil. To explain: A number two foot is approximately four inches in diameter at the coronet and five inches

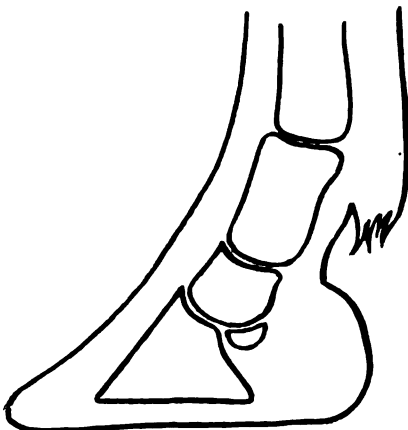

FIG. 1.—THE FOOT PRESENTS A CONCAVED FACE

at the base or ground surface with a five inch length of tread. This foot to be symmetrical should be two inches high at the heel and four inches at the toe. With a natural growth of horn in two months (about the average time I think a set of shoes will last including rural

horses) the hoof would grow about one-half an inch. By correct ratio this growth should be one-quarter inch at the heels, three-eighths at quarters and half an inch at the toe. For the hoof to retain its symmetrical rate of expansion the width at the base should be a gain of  $\frac{3}{8}$  of an inch, or a total of  $5\frac{3}{8}$  inches against the original 5 inches of two months previously. But having been securely nailed to the non-expanding iron, the hoof is practically of no greater width than when shod.

So far, the horse is sound for the foot can endure so small an amount of restriction. However, on the old shoe's removal the hoof is reduced to its original length, the foot is a little smaller than before from its two months compression, and the new shoes are nailed on. As time goes on the foot grows yet smaller—that is the walls of the sides become more and more perpendicular. This lateral compression concaves the sole in front of the frog more than natural and forces it upward against the under surface of the coffin bone. This crushes the tissues between which secretes a slightly blood colored liquid, that permeates the sole. The visible evidence of this is a pink or plum color. This same lateral compression lengthens the hoof at the toe in proportion to its loss of width, but instead of crushing the laminae there, it pulls them apart leaving a ruptured space. The visible signs are discoloration of what was the white line determining the junction of the wall and sole which is now blood stained. In accordance with the extent of this injury the toe turns upward, so that viewed from the side it shows a concaved face, as illustrated by Fig. 1. Pronounced cases and of long standing terminates in the condition called "seedy toe"

Lateral compression of the hoof probably has its greatest effect about midway of the foot's length and immediately opposite the rear points or heels of the coffin bone (see A in Fig. 2). These points are exceedingly thin and with irregularly serrated edges, and are so sensitive to injury that even a slight pressure will lacerate the tissues incasing them. Effects from injuries at this place are followed by corns that appear at that part of the sole between the walls and bars.

Costs continue to advance. Are you raising your selling prices in proportion? The period has long passed when the blacksmith could absorb the extra cost

which he is required to pay for supplies. If you have not already done so, better face the rising cost situation squarely and put it up to your customers in the same way.

The next course in horseshoeing at Cornell starts January first. Those interested in obtaining a thorough knowledge of this profession will write Prof. Asmus at Cornell, Ithaca, N. Y., for full information.

Have you run over your accounts recently in order to see if they are running over? Keep your debtors from getting be-

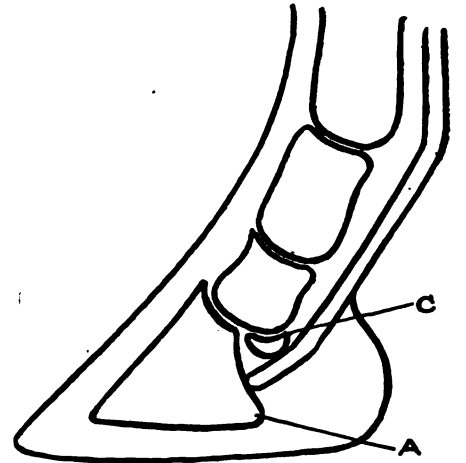

FIG. 2.—SLIGHT PRESSURE MAY LACERATE THE TISSUES

hind by paying constant attention to their debts. Remember, the money they owe you belongs to you just as much as that which already rests in your wallet.

There are just three ways of knowing things—first; by experience, second; by listening to others, third; by reading, and of the three they tell us experience is best. And it is, too, but it is mighty slow for these high-speed days. By listening to others your field of acquiring knowledge is a little larger but by reading you bring yourself into touch with the whole world. THE AMERICAN BLACKSMITH is read by blacksmiths in every corner of the English-speaking world.

## Thoughts on Timely Topics

BY THORNTON

### Cheery Censure and Caustic Comment

THE FOLLOWING IS NOT intended as a slam at the present because in our candid opinion there is no time since its beginning that we would sooner live in—but then that is another story—maybe we can tell it some other time. So to resume — we are going to speak of something entirely new. Something that hasn't engaged the minds and attention of the people for lo—these many minutes—at least one and a half. We refer to that noble, long suffering, hero—Hi Cost O' Living. Bang!! . . . (never touched me). To our notion the world and



particularly our own gre-e-a-te-e and glo-o-re-us country has never more closely imitated Paradise than it does right now with its deep-cushioned comforts to say nothing of its many things to eat—wear—and drink. The standards of life are happily rising. We have better homes, better automobiles, better books, better theaters, better trains, better jobs and better everything. Everything is on the rise. We have higher wages and higher prices. And for real excitement there is nothing to compare with the aviation contest for the high altitude record that is taking place in every household, between the pay envelope and the cost of necessary luxuries.

There was a time when a man would grow stout and raise a big family to boot on one-fifty a day. But the same stipend today will hardly keep the Flivver in gas to say nothing of the four rubber teething rings which it chews up every so often.

The time was when a chap who took fifty dollars away from the pay clerk every month was considered a young nabob. Today the little half-century note won't meet the landlord on his monthly round of extraction.

And two years ago when you spoke of a "friend who makes a hundred and a quarter a month" you were accused of hoboubling with the rich, the "400" and the livipolloi. And today—how far will one twenty-five per moon carry a man, wife and ten growing appetites today with potatoes at twenty cents per eye and pork forty cents per grunt?

Why a family that had difficulty in disposing of forty dollars in a week's time, years ago, had two kinds of pie twice a week and a chicken on Sunday now has difficulty in getting away for the summer, to say nothing of running out of funds long before they've seen the twenty-second installment of the "Terrible Terrors of Tessie" that is running at the corner film emporium.

And when it comes to purchasing the requisites of a home banquet of seven courses in honor of a son or daughter's "debt-blew" the family exchequer will hardly reach to the fourth course and the potatoes have to be mashed to fit.

I'll tell you the high cost of living is causing untold misery in this day and nation. Why, it's about as hard for a man to purchase a few bottles of champagne for a New Year's cele-

bration as it is to get a ward heeler to accept a bribe.

And still there are lots of smiths who seem to think that they can continue to support a growing family on smithing prices as arranged by their grandfather fifty or sixty years ago.



#### Philip Smith Dead—Emery Wheel Broke.

Philip Smith, a blacksmith, 66 years old, died at Chillicothe as the result of an unusual accident the other day. Smith was grinding the blade of a road grader when the emery wheel broke. Part of it struck him and crushed his skull.

#### Blacksmiths are Guests at Banquet.

The blacksmiths of Santa Rosa, California, and the surrounding territory, were tendered a fine banquet by the Capwell Horseshoe Nail Company, through its coast representative, H. H. Standard, and its traveling representative in this territory, Miles Tilden. There were about twenty mighty men of muscle and brawn present and the feast was thoroughly enjoyed and the hosts were cordially thanked for their hospitality.

#### Fellow Workers Honor Blacksmith Foreman.

Adolph Boos, Sr., foreman blacksmith at No. 7 Colliery of the Pennsylvania Coal Co., and one of the oldest men at the anvil in the Pittston district, was tendered a pleasant surprise recently when several of his fellow workmen visited his home, and presented him with a briar pipe, and his good wife with a ten-dollar gold piece. The affair was in honor of the forty-eighth anniversary of Mr. Boos' connection with the blacksmith shop of the Pennsylvania Coal Company. John Nicholson, who is employed at the shop and who is to leave in the near future for the west, was also presented with a fountain pen.

#### Thomas J. Farnsworth, Blacksmith.

Thomas J. Farnsworth, a wealthy pioneer landowner and cattle dealer, who also founded the town of Buchannon, died at his home there, aged 87. The foundation of his fortune was laid in early life as a blacksmith. He served several terms in the house of delegates and the State senate. He was once president of the latter body, and by virtue of the office temporarily acted as governor of West Virginia, in the early '80s, when there was an elective contest over the Governorship. To Make Smith Shop Historic Museum.

The blacksmith shop of James W. Marshall, at Kelsey, California, is to be preserved as a museum. The committee having the matter in hand, intend to preserve the shop by purchasing the land on which it is located, and erect a building 50 feet square, which will house not only the old shop but will be a pioneer museum.

In it will be honored the pictures of all the pioneers of Kelsey, the furniture made by James W. Marshall, and many of his personal belongings. It will be the nucleus of a historical society, mining implements, and, in fact, everything that

pertains to the pioneers.

It was James W. Marshall, a blacksmith, who discovered gold in California.

#### Blacksmith Fleeced of \$2,400.

William Shepperly, a blacksmith, appealed to Chief of Police to arrest two clairvoyants, whom he charged with defrauding him out of \$2,400 which he raised by mortgaging his home. He asserts that they told him \$98,000 was buried in his yard, and that money was needed to "draw" it to the surface, where it could be reached.

Shepperly was told to prepare to dig in his garden, and left the clairvoyants in charge of the money while he obeyed their directions. They failed to appear and he learned they had hurriedly left town, taking his money with them. No warrant has been sworn out.

Several years ago Shepperly's wife, now dead, lost \$400 in a somewhat similar manner and \$300 at another time. On both occasions she was told that a fortune was hidden in the Shepperly yard, and when Shepperly was told that \$98,000 awaited him, he thought that there surely must be something to it, so he plunged heavily.

#### Assistant Foreman First Apprentice in Topeka Shops

George Frazer, general foreman of the blacksmith shops, announces the appointment of William Heber, who will act as assistant foreman. Mr. Heber has the distinction of being one of the first apprentices in the Santa Fe shops in Topeka.

**Blacksmith Prices Take Jump Everywhere**  
Nebraska smiths announce an advance in shoeing prices from \$2.00 to \$2.25 with resetting at 35 cents instead of 25.

Kansas blacksmiths have advanced prices on all work and shop owners in some localities announced that work in the future will be for cash only. The price of iron is double what it was before the war and cost of other material has tripled in some instances, the blacksmiths say.

Horseshoers in Washington city observing around and about them on all sides evidences of steady advances in the cost of living, have decided to advance their prices.

Needless to say, "it's the war." "Time was, before the war," say the local horseshoers, when horseshoes sold plentifully wholesale at the rate of \$3.25 a hundred. Now the price the shoers must pay is \$5.25. Horseshoe nails have advanced, they say, \$1.25 per hundred pounds.

The reason, say the shoers, is obvious. Billets of iron and steel formerly turned out to adorn the flashing feet of a thoroughbred mare, are now being used in shrapnel to kill off men in Europe. Consequently the horse-owner will have to pay \$1.50 to have his horse shod now, as compared with the before-the-war price of \$1.35.

#### Blacksmith Wants A Wife

With the 1916 Leap Year fast on the wane, there is at least one eligible who has not had a chance to surrender himself to the charms of the Leap Year girls. Postmaster A. S. Guffey, of Pittsburg, received the following letter from Davis E. Strait, of Hustontown, Pa.

"Wanted, a woman to keep house. I am a widower, 41 years of age, a farmer and a blacksmith by trade, American born, white and a Christian, sober man with five children, ages from two to ten years. Will give someone a good home and at my death a good share of my estate. Anyone desiring a home may write me at once."



## The Spirit of Christmas

HENRY VAN DYKE

"There is something better than keeping Christmas Day, and that is keeping Christmas. Are you willing to forget what you have done for other people and to remember what other people have done for you; to ignore what the world owes you, and to think what you owe the world, to put your rights in the background, your duties in the middle distance and your chance to do a little more than your duty in the foregoing; to see that your fellowmen are just as real as you are, and try to look behind their faces to their hearts, hungry for joy; to own that probably the only good reason for your existence is not what you are going to get out of life, but what you are going to give to life; to close your book of complaints against the management of the universe, and look around you for a place where you can sow a few seeds of happiness, are you willing to do these things even for a day? Then you can keep Christmas.

"Are you willing to stoop down and consider the needs and desires of little children; to remember the weakness and loneliness of people who are growing old; to stop asking how much your friends love you, and ask yourself whether you love them enough; to bear in mind the things that other people have to bear in their hearts; to try to understand what those who live in the same house with you really want, without waiting for them to tell you; to trim your lamp so that it will give more light and less smoke, and to carry it in front so that your shadow will fall behind you; to make a grave for your ugly thoughts and a garden for your kindly feelings, with the gate open—are you willing to do these things even for a day? Then you can keep Christmas.

"Are you willing to believe that love is the strongest thing in the world—stronger than hate, stronger than evil, stronger than death—and that the blessed life which began in Bethlehem nineteen hundred years ago is the image and brightness of the Eternal love? Then you can keep Christmas. And if you can keep it for a day, why not always?"



## Heats, Sparks, Welds

Why not repair the spring buggies and wagons in the fall? You can, if you go out after the business.

Lean collections will never fatten the

purse. Get after your slow payers now. Hammer on collection as well as on the anvil.

You cannot expect all of the business all of the time, but you won't know how much you can get unless you go after business with determination. Are you getting all you can?

Wish your neighbor craftsmen A Merry Christmas, and then show him that you really mean it by handing him a copy of THE AMERICAN BLACKSMITH. You can make the New Year a happy one for him by getting him to subscribe.

Are you, your shop and your business making good in a business way? If you cannot show a profit of at least 10% on the total amount of business done—an actual net gain of 10% in real money, you had better get into some other line.

A file of trade catalogues is almost as necessary to the efficient operation of the practical smith-shop as a file of the other kind. Trade catalogues are important books of the trade. They contain information on your business that you can get from no other source. Keep them on hand in a handy place.

Did you take our last month's hint; if not, better do so right now? The suggestion is a good one, and will bear repetition, and then too, you will be surprised how bright and cheerful the shop can be made with a good coat of white wash. It will certainly make the days of the closed-door season more cheerful.

This is working Uncle Sam's little dollar pretty hard, but why not try it? For one of Uncle Sam's greenbacks you can have THE AMERICAN BLACKSMITH sent to any one who may reside within the boundaries of the United States—get six months' credit upon your own account, and bring the brightest kind of a smile to our face.

What do you think of it? Mr. Camp's article on Lameness and Shoeing contains much food for thought for the average practical horseshoer. Mr. Camp places his theory and ideas before the reader in a clear, clean-cut, understandable way. He will set you thinking along new lines. What are your ideas on the matter as presented by him?

Please your pocket book by placing your name on the Honor Roll. The matter of placing your name in that list of paid-in-advance readers is not a matter of tickling your bump of conceit, but it is a matter of pleasing your pocket-book. The saving you can make by taking advantage of our long time rates is considerable, if you subscribe for a long period.

Did you ever sit back and compare the craft of today with that of your grandfather's days? Look back and see what your grandad had to work with—the tools—the stock—the machines. Then consider the advantages you have today—the labor-saving devices—the time-saving tools—the temper-saving material. And yet you've got to know more to be a real live up-to-date worker and working right can make more money. Just sit back and think it over.

Fretting, sweating, fuming and fussing was Tom Tardy, all because of a job of drilling which he had to do. When he started to use the old post-drill, he not only found that he had forgotten to repair the broken handle, but the drill table which he had cracked some weeks ago by hammering on it, fell apart and he also found several teeth missing in the gear wheels. When he explained the

situation to us we could not resist the temptation to ask him if he had ever heard of the word, "Preparedness"?

They are becoming fewer every year, we are glad to say—we refer to the smiths who seem to think that patent medicine signs and tobacco advertisements add to the appearance of their shops. If it is worth a patent medicine maker's and tobacco maker's good money to put signs upon your shop, how much more valuable would a few neat signs of your own mean to you? Try a few signs advertising your own business, and see if they will not put more real money into your own pocket than all the patent medicine makers can plaster upon the whole country side.

If there is an automobile opportunity in your present location, now is the time to prepare to grasp it. A bigger automobile activity is looked for between now and next spring—more motor vehicles will be sold between now and then, than ever before, and more money will be spent on repairs and accessories. Don't you want to get your share of this business? Prepare now to get into the game by spring. A few good books and a careful examination of the cars that come to you, will enable you to get a good start and to get a good side line which rightly belongs to the general smith.

Your 1917 business activities—have you planned them? Look back over the past year, think hard upon its performances; consider what the past year has done for you and the craft; carefully weigh the changes that have taken place. With the past year's facts before you, plan your business campaign for the coming year. Even if you do not work out all of the plans you make, it will give you something definite to work for, and it will point out to you the harbor for which your ship of business must be steered. Without some goal, some port in view, no ship ever made real progress.

You want success, of course, but do you want it hard enough to do the things that are necessary to attain it? The matter of success or failure is more a matter of wanting and desiring, than it is a matter of circumstances. If you want success hard enough and are willing to do the things necessary to get it, there is nothing that can keep it from your door. The number of smiths who are unwilling to do the things that are necessary in order to attain success for themselves, for their business and for their shop are all too many. Success does not come from a discussion of the war and local politics, nor by calmly warming the end of a shoe-keg and merely thinking about it.

Cut prices if you are in business solely and exclusively for your customer's benefit, but if you are in business for your own benefit, consider the matter of cutting prices in a purely, coldly business way. Business that is really worthy of the name is a matter of mutual welfare. A real business transaction must benefit all of the parties concerned, the customer must receive his money's worth and the seller must receive his legitimate percentage of profit for supplying the needs of the purchase. On this basis, price cutting is not business. Only one person profits when you cut prices, and that person is the customer. When you cut your prices, you cut your profit, you cut into your competitor's business, you cut down your revenue, you cut down your chances of paying your bills, and finally the jobber cuts you off his credit list, and when he does this, your business throat is cut.



# Our Honor Roll

## AND STILL THEY COME

More and more readers are taking advantage of "Our Honor Roll" every month and it is becoming more difficult each month to find a place on the list of Honor Subscribers. If you do not know what a saving you can make by taking advantage of Our Long-Time Rates, look over the table of rates and see just how you can save money and at the same time insure your subscription account. Sharpen your pencil and get down to actual figures and then get your name on this list of Readers who are paid up well in advance.

U. S. and Mexico	Canada	Other Countries.
2 yrs. .... \$1.60 save \$ .40	..... \$2.00 save \$ .50	..... 10 sh. save 2 sh
3 yrs. .... 2.00 save 1.00	..... 2.70 save 1.05	..... 14 sh. save 4 sh.
4 yrs. .... 2.50 save 1.50	..... 3.20 save 1.80	..... 18 sh. save 6 sh.
5 yrs. .... 3.00 save 2.00	..... 3.75 save 2.50	..... 1 £ save 10 sh.
10 yrs. .... 5.00 save 5.00	..... 7.00 save 5.50	..... 1 £ 14 sh. save 1 £ 6 sh.

Send your order and remittance now—today. Don't wait until you forget all about it. You'll never regret it. Our subscription insurance saves you money. The sooner you begin saving, the more you save. There is no better time than NOW.

NAME	Subscription Paid to	NAME	Subscription Paid to
The Fix-It Shop, Utah	July, 1935	J. Carl, Iowa	May, 1924
J. A. Torray, Mass.	Dec., 1933	J. E. Little, Pa.	May, 1924
W. C. Watt, Kansas	Dec., 1930	H. I. Brenzle, N. Y.	Apr., 1924
I. J. Stites, N. Y.	Jan., 1929	W. E. Parr, Iowa	Apr., 1924
Waddington Farm, W. Va.	Mar., 1928	F. Sramek, Nebr.	Apr., 1924
E. A. Krehbiel, Kan.	May, 1927	L. A. Hulstrand, N. D.	Mar., 1924
A. A. McLean, Nev.	Feb., 1927	J. E. Ray, Minn.	Mar., 1924
C. M. Adams, Conn.	Jan., 1927	A. Hulstrand, N. D.	Mar., 1924
Platinum Shoeing Shop, Colo.	Dec., 1926	W. F. Riske, Wisc.	Mar., 1924
John H. Schmelder, Cal.	Dec., 1926	H. Roeschwetter, Mo.	Mar., 1924
J. Taylor, Calif.	Oct., 1926	W. B. Briant, N. J.	Mar., 1924
J. Clarke, Jr., Queens, Aust.	Aug., 1926	A. Bosch, N. Y.	Mar., 1924
J. A. Buchner, Mich.	July, 1926	D. Van Valkenburg, Mass.	Feb., 1924
H. Mitchell, N. Y.	July, 1926	A. R. Johnson, R. I.	Feb., 1924
M. Broton, N. D.	June, 1926	F. Jacobs, Ohio	Feb., 1924
A. Schmitt, Nebr.	June, 1926	A. J. Ferry, Illinois	Jan., 1924
D. Ackland & Son, Man.	May, 1926	E. K. Walker, Calif.	Jan., 1924
H. Pirret, Ore.	May, 1926	H. D. Erskine, Vermont	Jan., 1924
J. Sinclair, W. Australia	May, 1926	E. Fowler, Pa.	Jan., 1924
P. Sowa, Oregon	May, 1926	Breen & Son, Ireland	Dec., 1923
E. P. Digan, S. Australia	Apr., 1926	M. Lamoureux, Ohio	Dec., 1923
P. A. Peterson, Iowa	Apr., 1926	C. R. Davis, N. Y.	Dec., 1923
G. F. Bowers, Okla.	Apr., 1926	F. W. Copeland, Kansas	Dec., 1923
W. Pochelo, Oregon	Mar., 1926	J. L. Tomlin, Kansas	Dec., 1923
A. Garver, Ohio	Feb., 1926	H. A. Davis, N. Y.	Dec., 1923
C. Burton, Mass.	Mar., 1926	E. H. Troyke, Illinois	Dec., 1923
J. F. Murphy, Nev.	Jan., 1926	D. B. Johnson, Iowa	Dec., 1923
F. Kearnes, Illinois	Jan., 1926	S. Horton, Calif.	Nov., 1923
J. N. McIntire, Pa.	Jan., 1926	J. Spratt, Mass.	Nov., 1923
W. Post, N. Y.	Jan., 1926	F. Watkins, N. H.	Nov., 1923
Powell Brothers & Whitaker, Eng-land	Jan., 1926	Koppnis, Ala.	Nov., 1923
O. Temple, Idaho	Jan., 1926	Y. C. Lanert, S. Australia	Oct., 1923
N. Karolewicz, S. Dak.	Jan., 1926	W. B. Abell, N. Y.	Oct., 1923
E. L. Lain, N. Y.	Dec., 1925	W. R. Turner, Man.	Oct., 1923
J. A. Hulvey, Illinois	Dec., 1925	A. J. Brookman & Co., Vict., Aust.	Sept., 1923
Williams & Turner, W. Va.	Dec., 1925	C. Nelson, Nebr.	Sept., 1923
J. J. Devine, N. J.	Dec., 1925	H. M. Anderfuren, Calif.	Aug., 1923
P. Nelson, Minn.	Dec., 1925	Camp Brothers, Texas	Aug., 1923
M. Kennedy, Tas., Australia	Dec., 1925	L. C. Larson, Iowa	July, 1923
J. J. Wassmuts, Idaho	Nov., 1925	S. Effenar, South Africa	July, 1923
A. G. H. Mallett, Queens, Australia	Nov., 1925	G. L. DeWitt, Mont.	July, 1923
A. W. Speir, Ohio	Nov., 1925	W. W. Gregg, Texas	July, 1923
W. R. Clepper, Texas	Nov., 1925	W. R. Stroupe, N. C.	July, 1923
G. H. Iley, Mass.	Nov., 1925	O. C. Young, Michigan	June, 1923
Reynolds Brothers, Pa.	Sept., 1925	Otto Stippel, Pa.	June, 1923
F. W. Krenz, Calif.	Aug., 1925	A. Chapman, N. Y.	June, 1923
C. E. Allen, Nebr.	Aug., 1925	C. Birely, Md.	June, 1923
A. E. Spangberg, Oregon	May, 1925	F. H. Shupe, Pa.	June, 1923
D. M. Kile, Okla.	Apr., 1925	J. C. Stover, Pa.	Apr., 1923
G. Gullgren, Iowa	Apr., 1925	W. Schoonover, Pa.	Apr., 1923
G. Fredericks, Minn.	Mar., 1925	J. M. Rumler, Iowa	Apr., 1923
V. Prissnits, Wisc.	Mar., 1925	Lowndale Brothers, Mo.	Mar., 1923
E. Price, Illinois	Feb., 1925	J. Carswell, Ark.	Mar., 1923
D. C. Garber, Ohio	Feb., 1925	G. E. Glaaser, Ohio	Mar., 1923
J. H. Kunk, Illinois	Feb., 1925	F. Gath & Co., S. Africa	Mar., 1923
E. R. Hiteshue, Ohio	Feb., 1925	T. Bradley, N. S. Wales	Mar., 1923
H. F. Schreiber, Pa.	Feb., 1925	L. T. Needham, Illinois	Feb., 1923
J. S. Damm, Iowa	Jan., 1925	G. C. Disinger, Miss.	Feb., 1923
J. M. Withers, Hawaii	Jan., 1925	J. Hughes, Ohio	Feb., 1923
N. B. Quick, Pa.	Dec., 1924	J. Wieber, Minn.	Jan., 1923
F. H. Jarvis, Indiana	Dec., 1924	Z. A. Enos, Minn.	Jan., 1923
George Tatum, Jr., Fla.	Dec., 1924	W. G. Whee, Calif.	Jan., 1923
I. Clark, Va.	Dec., 1924	F. S. Bishop, South Africa	Jan., 1923
A. N. Estes, Va.	Dec., 1924	J. Curran, Arizona	Jan., 1923
J. Bailey, Manitoba	Dec., 1924	S. P. Harney, Mont.	Dec., 1922
E. G. Naylor, Md.	Dec., 1924	W. Breckner, Okla.	Dec., 1922
Halvorson Brothers, S. D.	Nov., 1924	J. Pabina, Nebr.	Dec., 1922
P. Schlicka, Washington	Nov., 1924	P. Fredericks, Iowa	Nov., 1922
H. E. Snyder, Oregon	Nov., 1924	L. O. Leulirs, Illinois	Nov., 1922
J. A. Stewart, Ky.	Oct., 1924	W. Lawson, New Zealand	Nov., 1922
C. Richenecker, N. Y.	Oct., 1924	W. O. Grant, Calif.	Oct., 1922
W. L. Berthoff, N. J.	Oct., 1924	W. H. Miller, Iowa	Oct., 1922
J. W. Hewson, S. Africa	Sept., 1924	J. S. Lee, Wash.	Sept., 1922
Ed. Larson, N. D.	Sept., 1924	A. O. Martin, Idaho	Sept., 1922
R. T. Monk, Illinois	Sept., 1924	O. A. Mortimer, Idaho	Sept., 1922
W. T. De Young, Illinois	Sept., 1924	H. J. Hyatt, Washington	Sept., 1922
C. W. Taylor, Pa.	Aug., 1924	N. J. Snow, Iowa	Sept., 1922
Charles Wells, Colorado	Aug., 1924	A. D. Standiford, Washington	Sept., 1922
H. G. Weaver, Pa.	Aug., 1924	T. Temkiewicz, Quebec	Sept., 1922
Working Men's College, Vict.	June, 1924	A. Pellifer, Ohio	Aug., 1922
F. M. Kennedy, Nebr.	June, 1924	W. D. Valentho, Iowa	Aug., 1922
R. C. Frederick, N. D.	May, 1924	G. Hoffman, N. Y.	July, 1922
H. L. Fenton, New Mexico	May, 1924	J. Erman, Ark.	July, 1922

NAME	Subscription Paid to	NAME	Subscription Paid to
W. K. W. Hansen, Pa.	June, 1923	A. W. Brememan, Indiana	Nov., 1920
Robert Tochter, Calif.	June, 1923	R. L. Whitfield, N. S. W., Aust.	Nov., 1920
J. Van Marter, N. Y.	June, 1923	McFarlane & Pratt, S. Africa	Oct., 1920
F. Norrie, Yukon Ty.	Jan., 1923	Thomas Scurr, New Zealand	Oct., 1920
E. Anders & Son, S. Australia	May, 1923	W. H. Finlay, New Zealand	Oct., 1920
Louis Carriage Works, Va.	May, 1923	J. Hawn, N. J.	Sept., 1920
S. Smith, Texas	Apr., 1923	C. L. Massey, Ark.	Sept., 1920
J. W. Haar, La.	Mar., 1923	J. Jordan, Cal.	Sept., 1920
D. W. Smith, La.	Mar., 1923	J. Jordan, Cal.	Sept., 1920
D. W. Smith, Rhode Island	Mar., 1923	L. O. Breke, Washington	Sept., 1920
E. A. Dillon, Nev.	Mar., 1923	R. D. Simkins, Penna.	Sept., 1920
D. F. Kuster, Washington	Mar., 1923	A. E. Reeve, Mass.	Sept., 1920
G. F. Johnson, Michigan	Feb., 1923	L. R. Garvin, Ohio	Sept., 1920
R. H. Keith, Iowa	Jan., 1923	G. W. Phillips, Utah	Aug., 1920
F. H. Joslin, Mass.	Dec., 1921	T. Chittenden, New Zealand	July, 1920
J. B. Scheidler, Indiana	Dec., 1921	O. Smith, Pa.	July, 1920
J. H. Ickes, Pa.	Dec., 1921	F. A. Poole, South Africa	July, 1920
E. Willis, Colorado	Dec., 1921	C. Gibson, Ill.	July, 1920
J. Delane, Nebr.	Nov., 1921	H. M. Whitman, Neb.	July, 1920
O. M. Johnson, Miss.	Oct., 1921	The Goldfield Diamond Drilling Co., Victoria, Australia	July, 1920
J. K. Gilincki, Mich.	Sept., 1921	G. M. Robben, Kans.	July, 1920
H. Feldus, Nebr.	Sept., 1921	R. J. J. Rees, S. Australia	July, 1920
R. Murray, Calif.	Sept., 1921	A. C. Morrell, N. B.	June, 1920
A. Hammond, Calif.	Sept., 1921	G. Moran, N. Y.	June, 1920
P. Wedel, Kans.	Sept., 1921	H. Fast, Man., Can.	June, 1920
A. Harper, Mont.	Aug., 1921	L. Underhill, California	June, 1920
L. E. Bonton	Aug., 1921	F. Felts, Ohio	June, 1920
R. Goldschagg, S. Afr.	July, 1921	W. M. Puryear, Ala.	June, 1920
C. Hammerstram, Minn.	July, 1921	W. L. Patterson, Okla.	June, 1920
A. S. Pratt, New York	July, 1921	D. Hardy, Vict.	June, 1920
E. H. Spain, Ariz.	July, 1921	E. Malpas, S. Australia	June, 1920
W. Voigt, S. Afr.	June, 1921	A. J. Hamburg, Ohio	June, 1920
J. M. Werl, Pa.	June, 1921	C. M. Hooton, Okla.	June, 1920
S. Budd, New Guinea	May, 1921	C. L. Graf, Ohio	June, 1920
H. Baker, Aust.	May, 1921	A. Mellum, N. D.	June, 1920
F. E. Smith, Vermont	May, 1921	N. Cobb, Wisc.	May, 1920
A. J. Hatch, Maine	May, 1921	O. Houser, N. Y.	May, 1920
W. Cornwell, Pa.	May, 1921	A. Donahue, N. Y.	May, 1920
W. F. Kline, Kansas	May, 1921	J. A. Schmitts, N. D.	May, 1920
J. Kirkbride, N. J.	May, 1921	P. Wright, Calif.	May, 1920
T. Holloway, Kans.	Apr., 1921	J. Stell, N. Y.	Apr., 1920
W. Winget, Vt.	Apr., 1921	F. Greer, Queens	Apr., 1920
J. A. Johnson, N. D.	Apr., 1921	C. L. Morman, N. Y.	Apr., 1920
D. H. Laird, N. Y.	Apr., 1921	H. W. Fuhrop, Ill.	Apr., 1920
A. J. Prue, N. Y.	Apr., 1921	A. Stephens, Queensland, Aust.	Apr., 1920
C. A. Butler, Ohio	Apr., 1921	Alex. Zimmer, Ont.	Apr., 1920
E. Mossner, Queens, Australia	Apr., 1921	C. P. Hardy, Nebr.	Mar., 1920
W. C. LeBow, Mo.	Mar., 1921	Bockenschuh & Son, La.	Mar., 1920
William Pate, Mo.	Mar., 1921	J. Weber, N. Y.	Mar., 1920
A. T. Jameson, Colorado	Mar., 1921	Clark Bros., Cal.	Mar., 1920
C. Alexander, N. Y.	Mar., 1921	J. Hlernerz, Minn.	Mar., 1920
F. Fencil, Wisc.	Mar., 1921	W. H. Leonard, Penn.	Mar., 1920
H. Cornils, Oregon	Mar., 1921	G. S. Akers, Va.	Mar., 1920
C. Schmid, Nebr.	Mar., 1921	F. White, N. Y.	Feb., 1920
J. Schwarmann, D. C.	Mar., 1921	H. L. Place, S. Australia	Mar., 1920
M. Stettner, Minn.	Mar., 1921	Ed. Grimm, Tex.	Mar., 1920
C. Knudson, Iowa	Feb., 1921	J. H. Wildey, Penna.	Feb., 1920
S. Button, Kans.	Feb., 1921	J. F. Nasgowsitz, Wisc.	Feb., 1920
N. F. Hartsoe, Mo.	Feb., 1921	W. F. Leiss, N. J.	Feb., 1920
L. Qoenbr, N. Y.	Feb., 1921	C. M. Jacobsen, Utah	Feb., 1920
R. E. Worthington, N. Y.	Feb., 1921	I. Blough, Penna.	Feb., 1920
B. E. Doggett, Kansas	Feb., 1921	Hope Bros., B. C.	Feb., 1920
Shellhaas Fry, Colorado	Feb., 1921	A. Standley, Ohio	Feb., 1920
J. Tooes, Kansas	Feb., 1921	F. Ritter, N. Y.	Jan., 1920
W. T. Wilson, Mo.	Feb., 1921	W. Killus, Okla.	Jan., 1920
J. W. Wilson, Indiana	Feb., 1921	I. T. Hoy, S. D.	Jan., 1920
J. Schmid, Nebr.	Feb., 1921	D. Shearer, Ohio	Jan., 1920
E. Stee, New York	Feb., 1921	J. B. Windle, Iowa	Jan., 1920
A. R. Skerritt, New York	Feb., 1921	J. E. Erickson, Minn.	Jan., 1920
W. H. Starkey, Kans.	Feb., 1921	A. Fisher, W. Va.	Jan., 1920
W. Singleton, Pa.	Feb., 1921	I. J. Giguere, N. H.	Jan., 1920
J. Briere, Vt.	Jan., 1921	E. Gunther, Iowa	Jan., 1920
A. Bartlett, Vt.	Jan., 1921	L. H. Willson, Vermont	Jan., 1920
E. H. Manley, Mo.	Jan., 1921	D. R. White, Kansas	Jan., 1920
Neufeld & Giesbrecht, Kans.	Jan., 1921	P. Bianchi, Texas	Jan., 1920
W. C. Abbott, Ohio	Jan., 1921	R. S. Crisler, Ky.	Jan., 1920
Feldmeyer & Schaake, Mo.	Jan., 1921	T. A. Mahar, Me.	Jan., 1920
A. Josephit, Colorado	Jan., 1921	T. Horne, Ariz.	Jan., 1920
C. L. McNall, Mo.	Jan., 1921	H. B. Draper, Ind.	Jan., 1920
A. Turley, Kansas	Jan., 1921	L. H. Schoog, Wyo.	Jan., 1920
A. Seidel, Nebr.	Jan., 1921	H. A. Coats, Mont.	Jan., 1920
W. Ruple, Pa.	Jan., 1921	W. C. Young, Iowa	Dec., 1919
N. A. Englund, Iowa	Jan., 1921	H. Kraft, Calif.	Dec., 1919
O. Gerhardstein, Ohio	Jan., 1921	S. Barber, Iowa	Dec., 1919
W. C. Butter, Illinois	Jan., 1921	M. Martin, S. D.	Dec., 1919
J. L. Jester, Mo.	Jan., 1921	R. I. Ryberg, Iowa	Dec., 1919
G. A. Moffatt, Yukon Ty.	Jan., 1921	Dayable & Sons, Vict.	Dec., 1919
J. W. Irie, Utah	Dec., 1920	E. M. Crouch, Conn.	Dec., 1919
O. A. Huff, Pa.	Dec., 1920	R. Werk, Nebr.	Dec., 1919
J. T. Rowe, Iowa	Dec., 1920	J. R. Wilson, Md.	Dec., 1919
W. Parsons, Ontario	Dec., 1920	N. Buchanan, Ont.	Dec., 1919
Fissler Brothers, S. Dak.	Dec., 1920	P. Reif, Ohio	Dec., 1919
J. Krauhlec, Illinois	Dec., 1920	A. Larsen, Ida.	Dec., 1919
L. F. Kellholz, Pa.	Dec., 1920	H. Andersen, Iowa	Dec., 1919
F. Markgraf, Minn.	Dec., 1920	I. F. Powers, N. J.	Dec., 1919
S. Wright, New York	Dec., 1920	J. B. Horn, N. Mexico	Dec., 1919
T. P. Consodine, Mass.	Dec., 1920	J. G. Grandlund, Conn.	Dec., 1919
J. D. Fox, Nebr.	Dec., 1920	A. L. Barnum, Nebr.	Dec., 1919
W. Dreener, Washington	Dec., 1920	C. Legg, Kans.	Nov., 1919
A. G. Palmquist Minn.	Dec., 1920	E. Leiser, Pa.	Nov., 1919
J. E. Richards, Pa.	Dec., 1920	T. J. Furnish, Mo.	Nov., 1919
J. Berthelsen, N. S. W. Aust.	Dec., 1920	J. W. Mitchell, Conn.	Nov., 1919
D. Codere, Illinois	Nov., 1920	G. T. Whitten, N.H.	Nov., 1919
C. Fransen, New York	Nov., 1920	J. Knobloch, N.Y.	Nov., 1919
J. Delane, Nebr.	Nov., 1920	J. Mason, Ill.	Nov., 1919
J. H. Staate, Mo.	Nov., 1920	C. S. Klang, Pa.	Nov., 1919
George F. Wardle, S. D.	Nov., 1920	F. LaPlant, N. Y.	Nov., 1919
H. C. Strine, Pa.	Nov., 1920	G. Siders, Ohio	Oct., 1919
C. M. McNutt, Mass.	Nov., 1920	H. L. Farrington, N. Y.	Oct., 1919
J. M. Mapes, New York	Nov., 1920	C. H. Parquett, Vt.	Oct., 1919
W. Condon, New York	Nov., 1920	J. Villiger, Ill.	Oct., 1919
F. Strieff, Wis.	Nov., 1920	H. Lybart, N. Y.	Oct., 1919
L. P. Mortensen, Michigan	Nov., 1920		



## Fundamentals of Lathe Practice

### Cutting Speeds

JAMES STEELMAN

We have already learned how to determine the *rotational* or *angular* speed of the spindle. We have learned to do this, being given the rotational speed of the line shaft and the diameters of the various pulleys concerned and the number of cogs on the gears that may be connected up in any back gear arrangements. If we wish to avoid the calculations, we may do so by using a little instrument which enables us to determine, with the assistance of a watch, the *rotational speed* of the spindle. Such an instrument need not cost over \$1 or \$1.25. This information is valuable; but we need to go a step further in order to determine whether we have just the right rotational speed for the cut we are about to make.

Suppose we have a disk like piece of work secured in the chuck, and that we are going to take cuts from the face of this disk. We will begin at the *outer edge* and work inwards towards the center. Suppose the very first cut is to be taken in a circuit 7 inches in diameter. The first trip around will be 22 inches long. See A Fig. 1. That is, if we take one single shaving for a complete turn, the shaving will have this length. As we continue, working gradually inwards, but leaving the speed arrangements undisturbed, the diameter becomes smaller and smaller and the circuit round becomes shorter and shorter. Half-way in, for example, when the diameter of the cut is  $3\frac{1}{2}$  inches, the shaving of a complete turn is 11 inches in length. As we work still further inwards, the circuit dwindles and dwindles in length until at last it becomes next to nothing at all. *Note this fact, however.* It took just as long to take the innermost cut as it did to take the outermost one. We got a 22-inch shaving in one turn, and we get a shaving next to nothing in length in one turn. If we cut the chip at the right rate at the beginning, we must have been wasting time from then on. If the power in the belt, the strength of the lathe and the ability of the cutting tool were quite equal to cutting a chip at the rate of 22 inches in 4 seconds, then we should have been able to take the chip when half-way in to the center—I mean the 11-inch chip—in 2 seconds. That is, we could very well have altered our speed ar-

rangements for this cut so as to make the spindle rotate twice as rapidly. In fact, from the beginning on to the finish, we should have been speeding up the spindle every now and then.

It is not difficult to determine what the changes should be as we work inwards. See Fig. 2. First, we make sure that we are starting right. Then, work inwards. See Fig. 2.

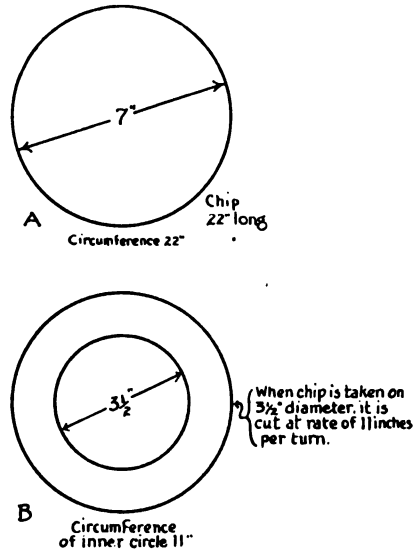

FIG. 1.—THE FIRST TRIP AROUND WILL BE 22 INCHES LONG

First, we make sure that we are starting right. Then as we go inwards, we speed up. When the diameter of the cut has become  $\frac{3}{4}$  of what it was at the start, the rotational speed of the spindle may be made  $\frac{4}{3}$  what it was. When we are at the  $\frac{5}{8}$  point, we make the rotational speed  $\frac{8}{5}$  what it was *at the start*. When we get to the  $\frac{3}{4}$ -point, we make the rotational speed  $\frac{2}{1}$ —that is, double. When we get to a diameter of  $\frac{1}{4}$  the original, we make the spindle rotate  $\frac{4}{1}$  times as fast. That is, we find out what fraction the diameter of the present cut is of the first cut. We then turn the fraction upside down. This represents the new rotational speed as compared with the rotational speed *at the start*.

Suppose we get everything connected with the speed arrangements just right for a cut 9 inches in diameter. When we have worked in to a 7-inch diameter, this new diameter is  $\frac{7}{9}$  of the old. Accordingly, we may make the rotational speed of the spindle  $\frac{9}{7}$  times what it was at the beginning. That is, we can speed up about 25 per cent. When the diameter of the cut has gotten down to 5 inches, the diameter is now  $\frac{5}{9}$  what it was at the start; so that we may make the rotational

speed of the spindle  $\frac{9}{5}$  as fast as what it was when we began. This means that we can run nearly twice as fast as at the start.

However, there is one good thing about working inwards to the center and leaving the speed arrangements alone. As we go in, the cuts are taken more and more slowly; so that the cutting tool is more and more relieved and the lathe is less and less pressed. We may be wasting time, but we are not letting things drift towards breaking the tool and straining the lathe. If we were to begin at an interior point and work further and further outwards, then the fact that we began right would mean that as we worked outwards, both machine and tool would be put to heavier and heavier duty.

We may have work to do of such a character that we will need to work from the inside out. Under such conditions, we must be on the alert. We should not start at such a speed as to put either cutting tool or lathe to its full capacity. We should begin with a speed very distinctly less than what could be used for the first round and be on the alert to slow down from time to time. If we go the limit with the first cut, the cut next outside will be beyond the limit.

It will be understood from the foregoing, perhaps, that it is important to know what the limit is for the starting cut. Only general direction can be given. A good deal depends on the character of the metal in the work. Brass is fairly easy to cut. Ordinary cast iron and low carbon steel are less difficult than high carbon steel. Then, too, the *condition* of the metal plays a part: this is especially true of steel. Steel work may have hard spots or it may be harder than it should be because it has not been properly annealed or has not been annealed at all. Then the speed with which a chip may be cut depends on the steel in the tool. A high grade of ordinary tool steel (carbon tool steel) will under proper conditions make a cut in cast iron or annealed low carbon steel at the rate of 30 feet per minute. A high grade of high speed steel will cut the very same material under proper conditions at the rate of 70 feet per minute. In one case, what is meant is that the chips are peeling off at the rate of a length of 30 feet in one minute; in the other case, at the rate of 70 feet of length in a minute.

Whether chips are being cut at the rate of 30 feet a minute can not be determined simply by finding



out the rotational speed of the spindle. We need to know that and something more. We must know in effect the diameter of the circuit of the cut. This should be multiplied by  $3\frac{1}{7}$ , or, what is the same thing,  $\frac{22}{7}$ . This gives us the length of the circuit—that is the chip length for one turn of the spindle. For example, suppose we are about to make a cut, 14 inches in diameter. See A, Fig. 3. The length of the cut, measured all round the circuit, is found by multiplying 14 by  $3\frac{1}{7}$ . This gives us 44 inches. Having the chip length for one turn of the spindle, we get the total chip length for one minute by multiplying by the number of turns in one minute. Thus, suppose we are making the 14-inch cut with the spindle turning 9 r. p. m. As we get 44 inches in one turn, we shall in 9 turns get  $44 \times 9 = 396$  inches in one minute. We get this to feet by dividing by 12, the number of inches in one foot. The result is 33 feet. This means that the cut will be made at the rate of 33 feet per minute. If we are going to keep within the limit of 30 feet per minute, the lathe has its speed arrangements set at too high a rate—9 turns of the spindle a minute is too rapid. Try 8. We multiply  $44 \times 8$  and get 352 inches. Dividing by 12, we get  $29\frac{1}{3}$  feet. We can handle this all right. Now notice what a small difference in the rotational speed may mean the difference between overtaxing the cutting tool and giving it work at a proper and safe rate. Nine turns a minute is too fast; eight turns a minute is safe.

Take another example, one in which the diameter of the cut is comparatively small. Suppose we want to cut ordinary cast iron, beginning with a cut  $1\frac{3}{4}$  inches in diameter. See B, Fig. 3. Multiplying  $1\frac{3}{4}$  by  $3\frac{1}{7}$ —that is,  $\frac{7}{4} \times 2\frac{2}{7}$ —we get  $5\frac{1}{2}$  inches. This is the circuit of the cut and corresponds to one turn of the spindle. Nine turns a minute would give a total chip length of  $49\frac{1}{2}$  inches ( $5\frac{1}{2} \times 9$ ); that is, something over 4 feet. This is too slow. We could afford to have the speed fully 6 times as rapid, even with high grade carbon tool steel. With high grade high speed steel, we could go still faster. So then, with high grade carbon tool steel, we could afford 54 turns a minute with the spindle. In proof of this, we multiply  $5\frac{1}{2}$  by 54 and then divide by 12. We get  $24\frac{3}{4}$  feet per minute. This shows we could even have a

turn or two more per minute with the spindle.

If we use high grade high speed steel with this last example, we shall need to speed the lathe up or else waste the expensive cutting steel. There is little or no use in buying

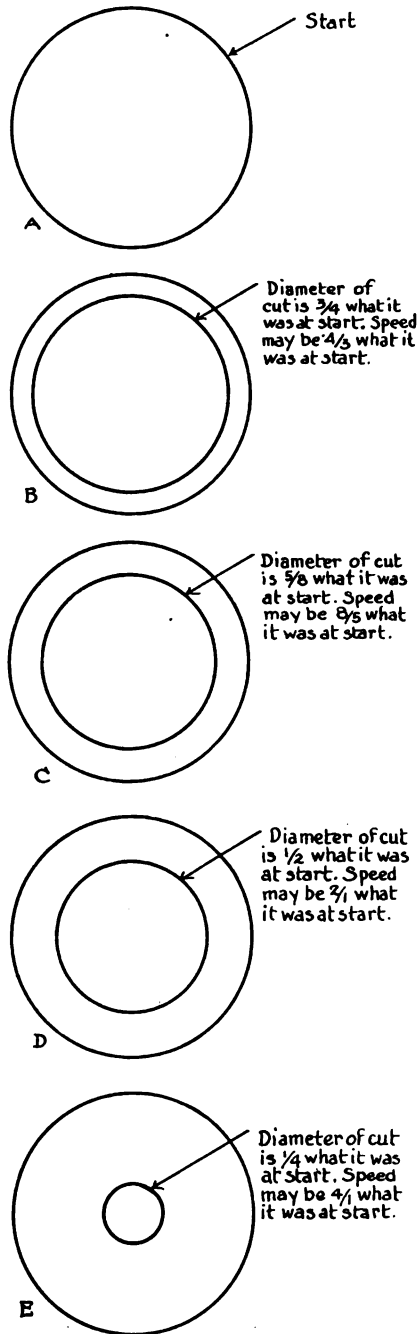

FIG. 2.—AS WE WORK INWARD THE SPEED MAY BE INCREASED

high grade high speed steel and then using it to make cuts at a rate within the capacity of a high grade carbon tool steel. A cutting speed of 70 feet per minute is permissible for moderate work such as ordinary cast iron or annealed low carbon steel. With a cut having a diameter of  $1\frac{3}{4}$  inches and the spindle rotating at 9 r. p. m., we found that we should

make the cut at the rate of something over 4 feet per minute. Call it 5 feet, so as to be safe. We speed up the lathe until the spindle rotates 14 times as fast ( $5 \times 14 = 70$ ). Instead of 9 r. p. m., we are entitled to 14 times 9, or 126, turns per minute. Let us see whether this is correct. One turn causes  $5\frac{1}{2}$  inches of metal to pass the tool; 126 turns will therefore cause  $5\frac{1}{2} \times 126 = 693$  inches to pass. The time is one minute, because 126 turns are made in one minute. We divide 693 inches by 12 and get 58 (nearly) feet per minute. We could work faster yet; but it is well not to push things to the limit.

It will be noted, perhaps, that in these examples, rather moderate rotational speeds for the spindle are required. Eight up to 126 are the r. p. m. employed. If the countershaft is not run too rapidly, comparatively slow rotational speeds may be gotten with the spindle with nothing else than the cone pulley. To get the slowest possible speed in this way, we use the little end of the cone pulley on the countershaft and the big end of the cone pulley on the spindle. If the resultant spindle speed is still too rapid and if the lathe has no back gearing, we may see what can be done in the way of slowing down the countershaft. The slowing of this shaft may be accomplished, (1) by reducing size of pulley on the line shaft, (2) by increasing the size of the pulley on the countershaft, and (3) by doing both things. If there is back gearing on the lathe, then perhaps a slow enough speed can be gotten by its use. If not, then the countershaft may be slowed in one of the three ways mentioned. This will have the effect of reducing all speeds.

It will be gathered, perhaps, from the examples given, that the slow spindle speeds come into use with large diameters of cuts and the rapid speeds with small diameter cuts.

A word of warning ought, I suppose, to be given in connection with high speed tool steels. These steels have only come into use in recent years. They enable work to be done more rapidly or else heavier cuts to be made. In either case, the lathe is operating against a more serious strain. Lathes built with a view to the use of high speed tool steels may be expected to have the various parts which come under the extra strain so built as to be capable of withstanding it. An old lathe may or may not have the required strength



in such parts—very probably, it will not have. Furthermore, the use of high speed steel, in making heavier or faster cuts, will demand more power. One may need to consider, accordingly, whether he has the power to drive a lathe making a cut 2 1-3 times as fast as formerly. It will be seen from what has been said that one will have to take into account other important matters besides the price of the metal per pound when he is contemplating using high speed steel. There is little or no use in buying such steel, if it is only going to be employed in the same duty as ordinary high grade carbon tool steel.

One may, if he choose, do a little experimenting. He should go about it with care, however; otherwise the lathe or cutting tool may give way or some injurious accident may occur.

### Practical Points For The Automobile Painter

M. C. HILICK

The small shop painter is almost certain to have considerable waste of material unless he exercises much care in the preparation and handling of the various paints, colors and varnishes. The opened container can never be closed to its original state, following the removal of some of the contents, and this permits a certain amount of evaporation to go on. It is advisable, therefore, to buy in the case of small, or comparatively small, daily requirements, with directions to have shipments made in quart, and even in pint, cans, in order to save the material from becoming thick or rancid before it may be used. This especially applies to all liquid and fluid supplies. In the matter of colors, it is also advisable to consider the extent of one's daily or weekly needs, when ordering, for here, too, there is chance for no small waste of materials which at this time run into money fast. In this buying, it is also well to get supplies direct, so far as possible, from the manufacturer. In this way a better quality of stock, as a rule, may be obtained, with the resultant advantage of saving the profits of the middlemen. The prevailing high cost of everything that goes into finished product makes it necessary to eliminate all extra expense.

Nevertheless, it is equally important to buy good stock; there is nothing that will hurt business more quickly, or to a greater degree, than the use of an inferior brand of paint shop supplies.

It is always the best policy to buy for quality first; then get the best quotation possible consistent with the quality of the goods. This, in the end, is the true economy, and it applies quite as forcibly to the small business as to the large one. The big shop is only the outgrowth of the small one; a legitimate expansion based, primarily, upon the square deal. When a can of color is opened, and part of the contents removed, it is economy to pour a little turpentine over the surface of the pig-

cases are the exception, not the rule. In the case of a car or carriage coming to the shop in a badly scarred or faded condition, it hardly ever pays to try and touch up the marred or fractured spots, for it is next to the impossible to get a correct match, and when this is done, the job is never satisfactory, and serves as a black eye to the paint shop. The safest and most economical practice is to touch the spots with some color close to the old, faded and broken one, and then go over the entire surface with a fresh coat of the original color. This fetches the job out in a one shade color, and leaves no chance for grumbling. It is a quicker method and a more efficient one.

There is sure to be some left over colors which it is possible to utilize by mixing them together and thereby develop something original which, given a striking name, will catch the fancy and please the color sense of some car owner who is looking for something different than anything displayed by his neighbors. Some of the shades of green, or brown, or blue, or red, when mixed in right proportions, result in a smart color suitable for almost any vehicle of the average run. Anyway, there is always a call for something unique or different than the usual list of colors, and this gives the opportunity for working off the shelves, the odds and ends which in time accumulate.

The left over bits of varnish, varnish-color, etc., may also be put to good use in the preparation of coatings for some of the out of the way parts of the car or carriage, where a mixture of various ingredients will answer fully as well as a more costly material.

During the cold months, it is a wise plan to keep the varnish supply stored in a warm place, where the heat is maintained at a uniform degree. The chilled varnish is dangerous to the painter's peace of mind; it likewise lessens his profits.

In the small shop, it is quite a common practice to mix different grades of the same varnish, as a means of getting something to meet the special or individual requirements of the business. This, as a rule, is a poor practice, and in the end is seldom satisfactory. The varnish maker is now able to furnish all grades and kinds of varnish, suited to every individual need, so that there is really no excuse for attempting to improve upon his work by shaking two or more makes or

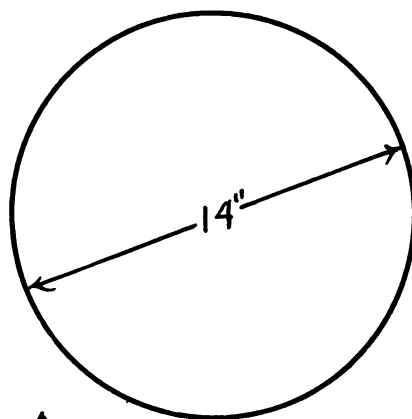

A Circumference 44"

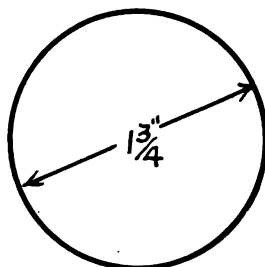

B Circumference 5 1/2"

FIG. 3.—THE CORRECT SPEED FOR ONE IS TOO SLOW FOR THE SECOND

ment to keep it soft and workable; then, as a second precaution, replace the cover as tightly as possible. A good practice is this, and it works to advantage in the handling of all colors, and most of the coarser paints, even. It is cheaper, for the most part, to obtain colors Japan ground, ready for simply thinning with turpentine, than to attempt to compound them from certain other pigments, however finely prepared such pigments may be.

It is, of course, necessary to often mix a color to match something which the vehicle owner may have in mind, or a sample of which he may be able to produce, but these

grades of varnish together. There are laws of chemistry involved which make the practice extremely uncertain, if, indeed, not disastrous.

In handling a small business, it is not best to employ a wide range of

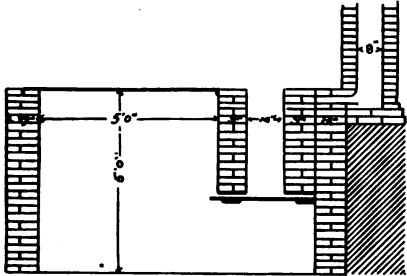

FIG. 1.—SECTION THROUGH PIT, FURNACE AND CHIMNEY

the makes and colors of the more sensitive sort; usually these colors need special treatment which the small shop painter is not in a position to give. There are a great number of fine, solid covering colors, easy to prepare and apply, with which the workman not widely experienced will have no trouble in using; from them he can get good results, and there will be no grumbling from the vehicle owner. For example: black, blue, (omitting the transparent ones) green, maroon, brown, and many of the reds, together with the yellows practically all of which are opaque. After putting on a coat of almost any one of these colors, some of the color may be taken and by adding a pint of rubbing varnish to three or four ounces of the color, after thinning it up somewhat with turpentine, a good varnish-color may be made with which the surface can be brought up with a single coat, in the case of medium priced work, for the finishing varnish, thus making a quick and cheap finish. It is by taking advantage of these little things that the painter located in the small shop is able to make both ends meet and have something left over for the bank account Saturday night.

Another point for the small shopman to observe, is to have his work, when the paint and varnish are drying out, placed in a room uniformly and well heated, and for quick results the higher the temperature, consistent with safety, the sooner it is possible to move the jobs out of the way, and get others in. The quick handling of work is a big factor in increasing the productive capacity of the shop.

When a customer argues about your raise in prices, just ask him if his dollar of today will buy as much from the butcher, baker or candle-stick maker, as it did five years ago, or even one year ago.

## Melting Furnaces for the Amateur Founder

WALTER J. MAY  
(English Mechanic)

Where metals having a fusing point above 1,000° F. have to be dealt with, a furnace of some kind is necessary. Generally speaking, it is desirable to have a furnace that will take a 50-lb. brass crucible as this enables one to melt up to steel in moderate quantities, although probably very few amateur founders would have pluck enough to tackle this. Taken as a usual thing, a 14 in. square crucible furnace attached to a chimney 20 ft. high will melt up to high-carbon steel such as files and such kind of metal, while a 15 in. furnace attached to a 30 ft. chimney will melt mild steel and wrought iron, this being about the limit for natural draught furnaces using coke as fuel, as when 3,000° F. is reached, things begin to get soft and pasty.

In all cases where crucibles are dealt with entirely by hand, the top of the furnaces should be level with the floor, except where less than about 30 lb. will be the total load, this arising from the fact that it is easier to deal with weights in this position, and that, in the event of a crucible breaking or slipping from the tongs, the molten metal does less damage

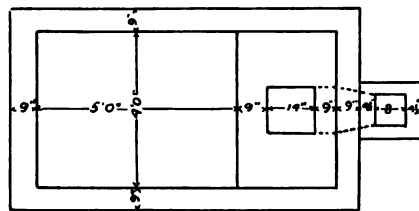

FIG. 2.—A TOP PLAN OF THE ARRANGEMENT IN FIG. 1

than when it falls from a height. Besides, it is much safer from a personal point of view, as there is less splashing when metal falls only a short distance, which considering that molten metal makes nasty burns, is a large consideration. However, in the ordinary course of events, where reasonable care is taken, there is no reason to anticipate accidents, but, still, on the lines of prevention being better than cure, reasonable precautions should be taken.

Probably the easiest furnace to construct would be an ordinary brick furnace, provided a chimney about 20 ft. high could be arranged, and this would be an easy matter, as a cast-iron pipe would be sufficient after the first 6 ft. above the outlet from the furnace. As there is no soot to be reckoned with, there would be no necessity to arrange for cleaning facilities, but as with a long run on the furnace the pipe would probably get hot, it should not be near woodwork. An 8-in. or 9-in. pipe would be needed to ensure quick draught, while there should be a damper in the brick part to regulate the draught, and a 14-in. square furnace having a chimney from 20 ft. to 25 ft. high, should melt anything up to wrought iron where good coke is used, time not being of so much importance to the amateur as to the trade worker.

In Fig. 1, a longitudinal section through the pit, furnace, and chimney is given showing the dimensions of each detail, while in Fig. 2 a top plan is shown. As the supports of the furnace have also to be

indicated, a floor plan is given in Fig. 3, and with these before him, any ordinarily intelligent craftsman should be able to do all that is required. The body of the furnace is lined with firebricks of good quality, set in fireclay with the thinnest possible joint, but the rest of the work can very well be of ordinary bricks set in mortar. Preferentially, the top of the furnace should be covered with cast-iron plates, but for the most purposes, if the top is composed of fireclay tiles, all requirements will be met.

Ordinary square bar-iron is sufficient for firebars, but a fairly strong grating over the pit is necessary for security. The cover to the furnace may be a fireclay tile banded with iron, as shown in Fig. 4, or may be formed of a varying number of fireclay bricks of sufficient length having iron clips, as shown in Fig. 5, the more convenient local method usually being preferred. The brickwork above the legs or supports is carried on 3 in. by 3/4 in. flat wrought bar, and the firebars by 1 1/2 in. square bar, as heat as well as weight has to be dealt with in each case.

In some cases a more or less portable furnace is needed, and where a small blast can be provided from a fan attached to existing shafting, or where a small electric motor can be put in, a furnace of this kind can be readily put up anywhere in an outdoor shed, as the fumes from the fuel can be passed into the open air readily enough without causing serious inconvenience. Of course, the fumes from coke are not pleasant, especially from gas coke or furnace coke highly charged with sulphur, but, still, as the blast applied is not great, there is not more fumes than can be dispelled by the air passing through an open shed. Where there is a chimney, of course the furnace would be arranged with a flue, and in many cases the draught would be strong enough to dispense with forced draught altogether, this being an advantage from every point of view.

The object to be secured in all crucible furnaces is not the too rapid combustion of the fuel, but rather the maintenance of a full heat for a long period, as the process of melting is rather a long one, as the heat has to pass through the walls of the crucible, and then be gradually absorbed by the metal within. It must always be remembered that metal absorbs heat until the fusing point is reached, and that it does not melt as soon as a flame touches it, while the heavier the pieces of metal the longer the time taken to absorb the heat and reach the fusing point. Incidentally it may be mentioned that most metals, when hot, absorb oxygen rapidly, and attempting to melt without sufficient heat is likely to cause the undue reduction of the metal to oxide, which for all practical purposes is useless.

In constructing a furnace for blast, it is well to arrange that it shall stand in

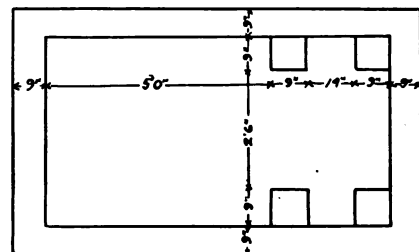

FIG. 3.—A FLOOR PLAN AND DIMENSIONS





a shallow pit, to enable one to have command of the crucible during lifting, a rough section of the whole arrangement being shown in Fig. 6. The frame of such a furnace would be preferably of 3-16 in. plate iron, held at the corners with angle iron, and lined with 4-in. fireclay tiles jointed at the corners with fireclay, the cross-section appearing as in Fig. 7. For smaller furnaces, lighter iron and tiles could be used, but their durability would be far less, and the difference in cost would hardly compensate for the shorter life of the apparatus. Cast iron plates could be used for the casing, if desired, and if the holes for the screws or bolts holding them together were made large enough to allow of play when the metal expanded or contracted with variations of temperature, there should be no serious risk of fracture.

In cases where there is an available chimney, the general shape of the furnace would be as shown in the section Fig. 8, the flue being lined with fireclay tiles, or it would rapidly burn out. For a 14 in. furnace the flue outlet should have an area of about 20 sq. in., in the position shown in Fig. 9, and this can be either rectangular or oval, as may be preferred, area rather than shape being the important point. Practically in all other respects this form of furnace is the same as that shown in Fig. 6, except that an induced and not a forced draught is used.

Outside these durable furnaces, various temporary or makeshift furnaces are possible, and one the writer came across some time ago was made from an old iron drum lined up with ganister. This was mounted on bricks, as shown in Fig. 10, and had a sheet-iron flue pipe lined with ganister, the whole making a furnace about 11 in. diameter inside, and taking a crucible holding about 15 lbs. of brass. Fig. 11 shows the way in which the furnace was stood on the bricks, and anyone with a little inventive ingenuity should be able to make a similar furnace.

In ramming up a furnace lining with ganister, the material has to be wetted down overnight, and then in the morning it is trodden and turned over, this being repeated until a stiff, tough putty-like mass is secured, this being rammed tight round a block acting as a former of the size required. The block is then withdrawn, and after the ganister has become dry the surface is washed over with a thick wash of ganister, dried and then fired until it is hard, after which it will

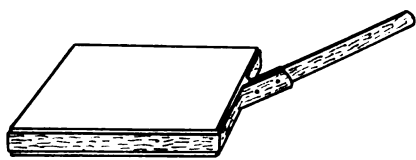

FIG. 4



FIG. 5

FIGS. 4 AND 5.—ILLUSTRATING HOW TO MAKE FURNACE COVER

last a long time with occasional patching.

As a general rule, square crucible furnaces are best for working, but, given sufficient space for fuel, round ones can be made to give satisfactory results. Usually these are lined with arch bricks set on end, as roughly shown in Fig. 12, fireclay being used with these. The backing can, of course, be of ordinary bricks

set flat in mortar, and except for outside work, these may be the softest bricks obtainable, "place" bricks being quite good enough for the job at any time, while they stand heat better than "stocks."

Possibly it may be as well to mention that in regard to metal melting, proper furnace coke, as free as possible from sulphur, should be used where it is obtainable, but at the same time hard gas-coke will melt anything up to bronze. Commercially, the furnace coke is cheapest, owing to its greatest durability, and it pays to have the best fuel as a general thing. All fuel must be broken to about the size of eggs, and nothing passing a 1 in. square meshed sieve should be used, or the furnace chokes with ashes and fine stuff, through which the air cannot pass with sufficient freedom. Unless there is enough air to supply oxygen in large quantities, the carbon is reduced at too low a temperature and melting is hindered.

The fire-bars should be wide enough apart to allow of the free ingress of the air while supporting the weight of the fuel and crucible efficiency and accumulations of ashes should not be allowed as they often check the free passage of the air.

Dry coke is always preferable to that which is damp or wet, and for this rea-

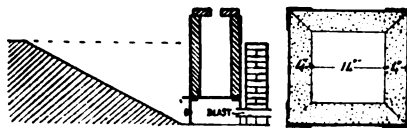

FIGS. 6 AND 7.—SHOWING SECTION AND TOP PLAN OF FURNACE

son the coke should be kept under cover. Besides this, as coke will take up quite 10 per cent of water, and it is sold by weight, it is necessary, from a financial point of view, that coke be purchased in a dry state. Coke costs several times more per ton than water, if we pay for water at the same rate as for coke, it is rather a losing game. At the same time, water does not seriously alter or injure coke so far as its content is concerned, as carbon may be taken to be insoluble in water, but it is a loss of energy to burn wet coke in any case.

Plumbago crucibles of some good make should be used, and these should be kept dry and in a warm place, if economy is desired. In all cases, crucibles should be kept for one class of metal, and not be used indiscriminately for anything that comes along. According to the metal, from twenty-five to fifty melts should be averaged from the crucibles, but necessarily this means that they be carefully handled and dealt with.

## Gas Engine Operation Made Simple—3

The Purchase, Installation, Operation and Troubles of a Gas Engine.

J. L. HOBBS

Lubrication and Care of Engines.

Lubrication, according to Webster, means to make smooth, to do away with friction, to make machinery run with minimum wear.

There is a false impression abroad in the land in regard to lubrication, which it is our desire to correct. The

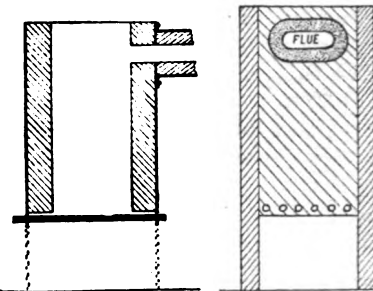

FIGS. 8 AND 9.—SHOWING SECTIONAL VIEWS OF SAME FURNACE

impression seems to prevail that all that is necessary to lubricate a piece of machinery is to take an oil can of some kind and pour a quantity of oil on the different bearings. This is only a part of the operation. To properly lubricate a bearing, it is necessary to do everything that will cut down the friction on that bearing. The worst enemy to a bearing is the dust and dirt which accumulates in the surplus oil around an oil hole. This will mix with the lubricant and go into the bearing in the form of a dirty, grimy paste and wears the bearing nearly as fast as though it were made for the purpose.

Perfect lubrication then, you will see, consists in first removing everything from the vicinity of the oil hole that might mix with the oil and get into the bearing. A cloth or piece of waste should be used, and after the cleaning process is accomplished, the surplus oil should be wiped off the part so that there will be nothing for the dirt to adhere to. By this method of lubrication, the wear on the bearings will be very small and as a result the engine will run two or three times as long with out replacing.

There are several methods which may be applied to lubricating a gas engine, force feed, or mechanical oiler, gravity system, grease cups splash system, and the time honored and ever faithful hand squirt can.

All of these systems will do their work properly when kept in proper condition, but none of them will work unless they are kept in condition to do their work.

The force feed system is used largely on the heavy engines and especially on the tractors, and all engines which are exposed to dirt and the elements. We will take up this system first. The tank or oiler, as we will call it for the sake of brevity, is generally placed no top of the cylinder, on account of the necessity of keeping the lubricating oil warm in cold weather to get the



best results. A number of little pumps and pipes, one of each for each bearing to be lubricated are supplied. The pumps are connected up on one or two shafts which in turn are connected with some working part of the engine to furnish the motive power. At the top of these little pumps is generally placed some kind of a sight feed, so that the operator can see how much oil is going to each bearing. Means are also provided for the adjustment of the amount sent to each bearing, to make the oiler economical and also efficient.

Most of the oilers are run by a small ratchet gear of some kind attached to either the crankshaft of

This not only shows the importance of the oiler, but the importance of the care of the oiler. The salesman was, of course, at fault in not telling the customer that the oiler would need a little attention occasionally.

The oiler we now have in mind has two sets of pumps. One is driven by the engine and is in use all the time the engine runs, the other is driven by one of the drive wheels of a tractor and is used only for lubrication of the gears in use when the tractor is moving about on its arrangement as it does away with wheels. This is a very convenient arrangement as it does away with the necessity of turning on the oil pipes which go to these gears every time you want to operate it as a tractor. It also saves considerable oil which would be wasted if the operator failed to shut off this part when the engine was not in use as a tractor.

A pipe will run from the oiler to each bearing that is to be lubricated. The pump will be set to deliver the exact amount of oil this bearing requires, and will not only save oil, but will save the engine frame from becoming besmeared with the waste oil. These pipes should be removed and cleaned out occasionally to prevent their clogging up and preventing the proper lubrication of the bearing which they supply. It only takes a few minutes to release both ends and blow through them with the mouth or by an air pump of some kind, then you know they are right.

Where an enclosed crank case is used there is generally some means provided for the dipping of a little oil out of the bottom of the crank case at each revolution for the lubrication of the crank bearings. The oil is supplied to the crank case by a separate oiler pipe or may be secured by allowing the surplus from the crank axle bearings to go to the crank case. There will be more oil picked up each time than is required for the bearing, but it will be thrown off and drain back into the base of the crank case where it makes another trip.

There is another method of lubricating the crank bearing. It is used in both the force feed and gravity oiling systems. In this method the oiler or pipe for this bearing delivers the oil to a small cup at the highest point reached by the crank in its revolution. A small piece of common lamp wicking is attached to the bottom of this cup. The oil runs

down onto the wick and a small projecting cup on the crank axle picks up a drop each time. This gives very good satisfaction on slow motion engines.

The gravity system of oiling is what its name would imply. The oiler or tank is placed in such a position that the oil will run to all the different bearings by gravity. A system of pipes, similar to the ones above may be used, even to the sight feed attachment. There may also be used with this system a separate oiler for each bearing. The oiler, in this instance, consists of an oil cup, generally made of glass, a little valve for regulating the amount to be fed, and for shutting off when not in use, and a sight feed attachment of some kind to show the amount going to each bearing. The adjustment is generally such on this oiler that the oiler may be turned on and shut off without interfering with the adjustment. This saves adjusting the oiler every time the engine is started.

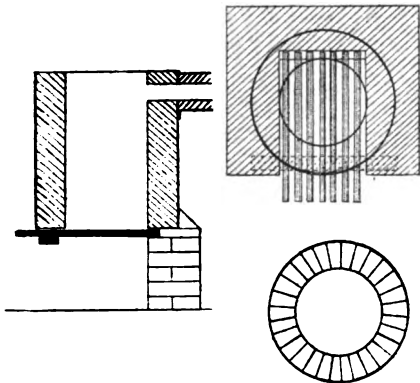

FIGS. 10, 11 AND 12.— SHOWING FURNACE MOUNTING AND CONSTRUCTION

the engine or the cam shaft. Care should be taken to see that this ratchet gear works uniformly every time. After a little wear takes place in these gears, the ratchet will sometimes fail to work every time, which will cut down the quantity of the lubrication. When this fails to a sufficient amount, it will cause the engine to lose power.

This brings to mind an incident where a tractor was being used for plowing. The salesman had told the owner that the oiler was automatic and would never need any attention except to add oil as it was used out. The engine began to fail on power. An expert was sent out with a new set of rings, which were placed in position with a liberal amount of oil on the piston, and for the time being remedied the trouble, but as soon as the surplus oil was gone the old trouble developed. Another expert was sent out and discovered at once that the oiler was worn in the ratchet so that it did not deliver oil to the bearings every time. Without stopping the engine, he adjusted the trouble and the engine almost immediately came back to its old power.

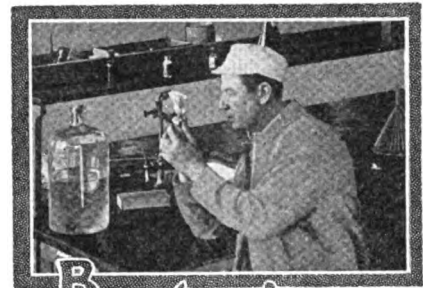

## Benton's Recipe Book

A cement for holding tools that persist in coming loose from their holder and handles is made as follows: Melt and mix well four pounds of black resin, and one bound of beeswax. After mixing the above thoroughly, add one pound of fine, dry brick dust, and work all together well.

Hard putty is usually a problem in the average shop. To make use of this material, break it up as fine as possible, getting the lumps as finely uniform as can be done with a pounder used on a hardwood surface. Then add a small quantity of linseed-oil, and work the putty into the proper consistency with the hand, kneading it until it is smooth and free from all lumps.

To temper a plow-share, M. O. S. sends in the following: First, secure a box, a couple of feet square and about six inches deep, and fill it with wet sand. Heat the plow-share on the edge only, so as not to spring it, and after the edge is sharpened and straightened, press two inches of the edge of the share into the wet sand and allow to cool. This will give you a hard, tough edge on your share, that will be hard to equal by any other method.

The faker has scored again. One of our Ohio readers has written to ask what he purchased. He tells us of a stranger



representing himself as a "stranded chemist" who was trying to pay his way to one of the large eastern chemical laboratories by selling a "discovery" that would revolutionize the plating industry. The stranger told of how he had spent all of his available cash in experimenting, how he had labored for years with one idea in mind and how finally he had succeeded and was on his way to reap the reward of his long years of toil. To cover his expenses he was selling small bottles of the "marvelous" mixture for the small sum of 25 cents. To demonstrate his plating mixture he took several pieces of brass, rubbed them with the compound, and immediately the pieces of metal took "an appearance rivaling silver plate." Of course, our reader purchased a small bottle and is now wondering what he got for his quarter. This is, of course, the old "silver-plating" fake with new trimmings. We have referred to it a number of times, but are glad to speak of it again if it will save any of "Our Felks" from being victimized and parting with their good, cold cash. The stuff sold by these fakers is simply mercury, dissolved in nitric acid. The coating or "plating" that it does will last perhaps a day, if that long. If the plating faker calls upon you, and tries to sell you a bottle of some "marvelous compound," no matter how picturesque his story may be, or how convincing his talk, you had best keep a tight grip on your wallet and whistle for the dog.

An idea is suggested by R. E. W. in which he mentions the use of printer's type cases for holding screws, nuts, bolts, washers, etc. Cases of this kind can usually be purchased for little or nothing from the local printer as practically every print shop has a number of these cases that have out-lived their usefulness. The divisions in the cases can be made to fit and suit practically any requirements by taking out any of the partitions that are not needed. In this way a large assortment of washers, nuts, bolts, screws, etc., can be kept in small space and properly separated so that the proper size can be quickly found.

A cement for fire bricks is asked for by M. H. T. He writes: "I wonder if you can give me a formula for a cement with which to repair fire bricks in a stove." In looking through the receipt book we find the following: Secure a quantity of fire clay and iron filings, take three parts of the clay to one part of the iron filings and mix with strong vinegar until a putty-like mass is formed. If very thin cracks are to be filled, use the mixture sufficiently thin to enter the cracks easily. In place of iron filings, iron borings may be used.

An aluminum cleaning hint which will interest the automobile repairman particularly because of the increasing amount of this metal used upon the modern motor car, is extremely simple, and simply calls for the application of a coat of kerosene oil on the surface to be cleaned and allowing this to remain on the metal over night. The metal may be cleaned in the ordinary way next morning.

A paint remover is asked for by M. E. M. We suggest the following: Make an emulsion of two parts of ammonia and one part turpentine. Shake the ingredients well and apply to the painted surface. This preparation softens the paint very quickly so that it can be easily removed. After using a paint remover, whether the above or any other kind, wash the surface thoroughly and carefully with alcohol be-

fore applying the new paint. This cleaning with alcohol is particularly advantageous on surfaces where a fine finish is desired.



## Queries— Answers— Notes

**The Old Barrel Lock**—I am interested in procuring information regarding the old-fashioned barrel lock. I saw something about it some time ago in your paper. Would like blue prints of same, or working drawings of it.

I would like to hear from some of the old smiths on forging lathe tools. Any information will be gratefully received.

B. C. LESTER, Nebraska.

**Our Journal in College**—I am using THE AMERICAN BLACKSMITH as a supplementary study in my courses. I have been teaching mechanical work in the State schools for seven years, and have been using THE AMERICAN BLACKSMITH with the best of results. I would like to see what other mechanical teachers think of using THE AMERICAN BLACKSMITH in class work.

I use THE AMERICAN BLACKSMITH in our mechanical classes as follows: I study the most important subjects for the students in their coming recitation, and call their attention to certain parts of the published article I want to emphasize. We discuss the article in class and by so doing, we get the good part, and if we find any error, we make note of it. Of course, one must use good judgment in selecting the good part of the article and detecting the part at fault (if there be any). One thing I have noticed and want to compliment you on and that is, whenever the Editor answers a question it is always correct and can be depended upon. I like the sketches and drawings, and especially Benton's Receipt Book, in fact, I like it all the way through. I have excellent success with THE AMERICAN BLACKSMITH in the engineering classes especially, as the boys get more interested than they would from a book.

H. T. FINNEY, Instructor Okla. Agri. Col.

**Wants to Build Trailers**—Please give me some information. In one issue you had an article on trailers for motor cars. Now please give me dimensions and method of construction of both for two-wheel and four-wheel trailers, also the method of attachment to car, more especially to the Ford car, which is most used in these parts.

R. ROBERTS, Transvaal, S. Africa.

**Balancing the Emery Wheel**—To balance an emery wheel which is heavy on one side (as most of them are) and makes a great noise, has been troubling me for

many years. At last, I have been able to solve the matter, so I will give it to those of the craft who have not this or some other good way to prevent the rattle. First remove the shaft with the wheel screwed on. Now insert a small pin in the center of each end of the shaft by drilling a hole into each end. Now take a pair of saw horses and place thereon pieces of straight smooth steel, get them perfectly level. Now place the bearings apart and let the pins rest on the bearings. When doing this the heavy part of the wheel will roll down and tell you where it is out of balance so you can mark the part of the wheel which seems to be heavy. Also mark the collars and wheel in some way, in order that the wheel may be removed and put back just the same every time. Now make two wood washers, one for each side of the wheel and near the outer edge, bore a hole and fill with lead enough to make the wheel balance. It should then stay in any position you turn it. You will, by using much or little lead, be able to get a perfect balance. Make the two washers a little larger than the collars or flanges on the shaft. In some cases it may need but one washer loaded.

A. J. BOSTWICK, Connecticut.

**Tempering, Welding and Forging**—Will you please answer the following questions: What is the best way to temper a cold chisel and punch? Can you tell me how to weld two pieces of steel together with borax; two pieces of iron? Will you tell me of several ways in which a pair of spurs can be made?

BRYAN HIXSON, Colorado.

**In Reply**—The successful making of a cold chisel depends almost as much upon the hammering of it and forging as upon the tempering and hardening. However, we will take for granted that we have a properly forged chisel ready for tempering. Heat the chisel to an even cherry red, about one and a quarter inches back from the cutting edge, then dip it into the hardening bath, for at least one and a half inches, raising and lowering it, so that no sharp dividing line will be apparent between the hardened part and the unhardened part. Now polish the end of the chisel with emery cloth or sand paper, and reheat very slowly to an even light blue color. When the light blue shows upon the polished surface, cool the chisel off.

To weld iron and steel by means of borax as a flux, the two pieces to be joined are properly scarfed, and then the ends to be joined are carefully heated to a welding heat. When at the proper temperature, the pieces may be removed from the fire, dipped into the borax, or, if more convenient, the borax can be sprinkled upon the surfaces to be welded, and then returned to the fire until at the proper welding heat. The two pieces are then taken out of the fire and lightly rapped upon the anvil to remove any cinders or dirt. The scarfed surfaces are then joined and the pieces hammered together.

It would require considerable space to detail the various methods of forging spurs, but in general, we may detail two of the processes. First, a piece of stock of the proper size may be taken and the end split for the wings of the spur or the two arms which come about the heel of the boot. These are forged and properly shaped while the other end is drawn out, given the proper curve and the end split to admit the little spur wheel which is riveted into place. The other method is



to build the spur up from three pieces of metal, one part is curved to go about the heel of the boot, then there is the shank and then the third part which holds the little spur wheel. These parts, after being properly shaped and forged, are welded together, and then filed smooth.

L. H. B., New York.

**NORTHEAST NEBRASKA BLACKSMITH AND WHEELWRIGHT PRICE LIST**

With the increasing cost of wood stock and other materials, the blacksmith must raise his charges for work. This list of prices is not too high and shops cannot afford to work for less. In some localities, they get more.

**Wagon Woodwork.**

New Tongue with Old Irons .....	\$ 4.00
New Axle .....	5.00
New Bolster, With Old Irons, Hind	
\$2.50; Front .....	2.75
Sand Board .....	2.25
Bent Hound .....	4.50
Hind Hound, each .....	1.75
Bolster Stake, each .....	.50
One Wagon Spoke, each .....	.35
New Spokes, in one wheel or more,	
each .....	.25
One Wagon Felloe .....	.35
New Felloes, in one wheel more,	
each .....	.33
Cutting Down Wagon and Setting	
Tires, 1½-inch .....	12.00
Cutting Down Wagon and Setting	
tires, 3-inch .....	16.00
New Reach, \$1.50 to .....	2.00
Wagon Singletree With Old Irons..	.65
Wagon Doubletree With Irons, 75c to	1.00
Wagon Neck Yokes .....	1.00

**Wagon Ironwork.**

Setting Wagon Tire, 1½-inch, each..	\$ .75
Setting Wagon Tires, 1½-inch, per	
set .....	2.50
Setting Wagon Tires, 3-inch, each..	1.00
New Set Tires, Put On, 3x¾ inch..	20.00
New Skeins, each .....	2.50

**Buggy Woodwork.**

New Pole With Old Iron.....	\$ 4.00
New Body With Old Irons .....	10.00
New Pole Circle .....	1.50
One New Buggy Shaft .....	1.75
One New Express Shaft .....	2.50
New Cross Bar in Shafts .....	1.50
New Buggy Spoke, 1 to 3, each....	.35
New Buggy Spoke, more than four..	.25
Whole New Rim and Setting Tire.	2.75
New Straight Reach, each.....	1.25
New Brewster Reach, each \$1.50 to..	2.50
New Axle Bed .....	1.50
New Spring Bar .....	1.25
New Head Block .....	1.25
New Buggy, Single Tree, Old Irons	.75
New Buggy, Doubletree, Old Irons..	1.00
New Neck Yoke .....	1.25

Prices given are for regular size wagon and buggy. Extra charges for heavy jobs.

New Spring Wagon Body up to Seats	10.00
New Buggy Body .....	10.00

**Buggy Ironwork.**

Setting Buggy Tire, One.....	\$ .75
Setting Buggy Tires, per set.....	3.00
New Set Tires, up to 1½ inch.....	7.00
New Set Axle Stubs, smaller than	
1 inch .....	7.00
New Set Axle Stubs, 1 and 1½-inch	10.00
New Set Axle Stubs, 1¼-inch.....	12.00
Welding and Setting Broken Axle..	2.50
New Clip King Bolt .....	1.25
New Fifth Wheel .....	4.00
Welding Leaf in Spring.....	1.00
Setting Buggy Axle .....	1.25
Putting on Guard Plates .....	12½
Fork Handles .....	.15

**Plow and Mower Work.**

New Plow Share, 12-inch, soft center.	\$ 4.00
New Plow Share, 14-inch, soft center	4.50
New Plow Share, 15-inch, soft center	5.00
Sharpening and Polishing Plow.....	.65
New Plow Point and Sharpening...	1.25
New Lister Share, Soft Center.....	5.00
Sharpening Lister Share .....	1.00
Pointing and Sharpening Lister	
Share .....	1.50
Sharpening Set of Shovels, 4 or 6..	1.25
Pointing and Sharpening Set Shovels	2.00
Polishing Shovels, per set .....	.75
New Landside Plate .....	1.75
Plow Handle, Bent, each .....	1.25
Plow Handle, Straight, each.....	1.00

**Horse Shoeing.**

New Shoe, per shoe .....	\$ .60
Re-Setting, per shoe .....	.35
Neverslip Shoes, new .....	1.00
Neverslip Calks, each .....	.07½
Trimming Feet of Pulling shoes	
each .....	.05
All Horses Roped or Racked, per	
foot extra .....	.50
Labor by the Hour .....	.65
(Labor by the hour means time only,	
charges to be made for all mate-	
rials and stock used.) Extra	
charge for all helpers' work.	
When using a power machine labor	
and use of machine, \$1.00 per hour.	
Neverslip Shoes, 0 to 3 .....	\$ 6.00
Neverslip Shoes, 4 to 5 .....	7.00
On odd jobs weigh all iron, charge 10	
cents per lb. for same and charge	
for bolts and rivets what the	
hardware stores retail them for.	

and rusted it tight, the crack naturally opening up somewhat when the cylinder became heated. After the crack had become tight, the packing was removed and the surplus lime scraped off. The cylinder jacket was then given a coat of paint for appearance's sake.

**Causes of Noisy Engine Action**

VICTOR W. PAGE, M. S. A. E.

After the automobile power plant has been used for a time, it is apt to become noisy and up to the time that a thorough mechanical overhauling is possible, the principal causes of noisy operation can only be located by a systematic search and a prompt recognition of various unmistakable symptoms. The smith who is about to take up the study of automobile repairing should familiarize himself with the causes of noisy action and know the parts that are most likely to be affected by depreciation after a season's use. As a guide for those who are not thoroughly familiar with gasoline engine construction, a sectional view of a typical stationary engine of standard design is presented in a special drawing prepared by the writer in which all parts of a typical single cylinder engine are clearly indicated. The reason the smith is asked to familiarize himself with the details of this type as well as with the sectional views of the automobile engines also shown, is that considerable repair work must be done by the country blacksmith on the engines used for farm power and for tractor propulsion as well as on those used in motor cars.

The designs shown are not the only possible arrangement of parts but it is not likely that the smith will be called upon to repair engines that will differ materially from the types illustrated. The relation of parts may differ, as for instance, a horizontal cylinder may be used instead of a vertical one. The valve action may be different in matters of detail and the cylinder may be provided with ribs for air cooling instead of having a water jacket for the circulation of that heat absorbing liquid. The number of cylinders may vary, in fact, automobiles may come into the shop for repairs that will have one, two, four, six, eight, or even twelve cylinder engines. The tractor power plants are usually of the simpler forms, the four cylinder type now predominating. On motorcycles, special two cylinder V-type engines will be found almost exclusively. Once the smith familiarizes



**The Automobile Repairman**

A cracked water jacket that was repaired in a rather curious way, was made tight as follows: A patch, made of heavy band iron, about two inches wide, was first carefully fitted to cover the crack, and about two inches longer than the crack at each end. Two pieces of thick asbestos board were then cut the same size as the band iron patch, and the center, about an inch wide, was cut out of each piece of asbestos. This left just a rim of asbestos, about one-half inch wide, all around. The asbestos rims were then placed over the crack, and the asbestos packed full of a mixture of equal parts of finely powdered quick-lime, and fine cast-iron borings. The iron patch was then clamped tightly over the asbestos and the lime mixture and the jacket of the engine was filled with water. The lime, upon becoming wet, forced itself into the crack,



himself with the principal parts of the simpler gas or gasoline engine it is certain that he will recognize similar parts of other engines and will understand the method of repairing to be followed.

A symptom denoting faulty engine action that is more readily recognized than any other is loss of power. This may be accompanied by noisy engine action and the noise

casting may then be lifted from the cylinder which will expose the valves and the tops of the pistons. Any carbon deposits present on the piston heads or in the combustion chambers in the cylinder head casting may be very easily removed by any form of scraping tool. The point of carbon removal and valve grinding has been previously considered so it will be unnecessary to go into

these nuts on any detachable head engine and the head will be bedded down most efficiently if the nuts are tightened about in the order indicated. In lifting off the cylinder head and replacing it, care should be taken not to damage the cylinder head gasket or in disturbing the sticky composition on the gasket on the contacting surfaces of the cylinder head or block. If the gasket appears to be dry, it may be coated with shellac, which is allowed to become "tacky" before the head is screwed down. After the retaining nuts are well bedded down the engine should be run for a few minutes without putting any water in the radiator in order to heat up all portions of the cylinder block and cylinder head. It will be noticed that it is possible to tighten the hold-down nuts somewhat after the engine becomes heated. Care should be taken to allow the cylinder casting to cool thoroughly before any water is placed into the radiator, and judgment should be exercised in running the engine so as not to damage it.

Usually when a gasoline engine becomes noisy, it may be considered an unmistakable indication that some part of the mechanism is deranged. The point to be looked for is often indicated by the kind of a noise and the point from which it comes. A sharp hiss always denotes the escape of gas under pressure. This may be through a leak in the petcocks, around a spark plug, from under a valve chamber cap, from a faulty seating valve cage or through a leaky cylinder-head gasket or packing. A whistling or blowing sound is generally caused by a leaky packing on a valve spring chamber cover plate or a hand hole in the crank case.

Faulty action of the inlet valve will result in back-firing or popping noises in the carburetor. A cylinder which has a defective spark plug and which misses explosions may cause "muffler shots" which are due to the ignition of unburnt gas charges from the missing cylinder in the silencer by the flaming gas from cylinders that are exploding regularly. Defective ignition timing or crossed ignition wires will also cause popping noises in the carburetor. A blowing back which causes vapor to issue from the air inlet of the carburetor is due to the inlet valve in some cylinder not seating properly. This same condition is sometimes produced by an excess

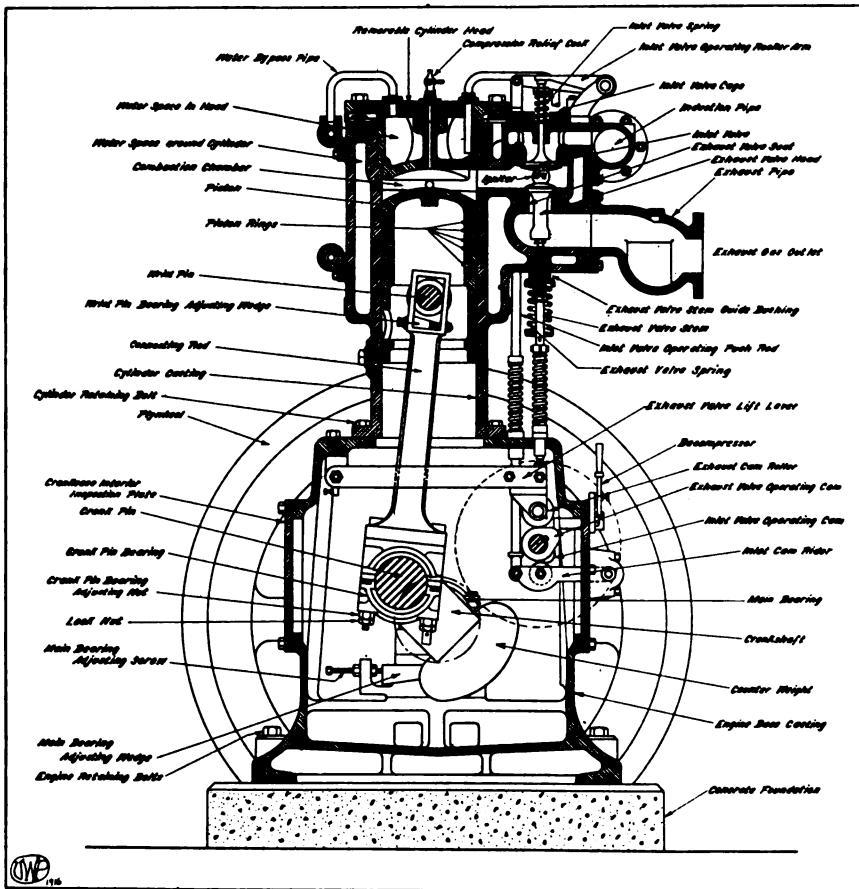

FIG. 1.—SECTIONAL VIEW TYPICAL STATIONARY GAS ENGINE SHOWING IMPORTANT PARTS

may form an important index to the cause of the trouble. For example, carbon deposits will produce pre-ignition and overheating which in turn cause noisy action of the engine. A sharp, metallic knock, very similar to that resulting from a loose connecting rod or main bearing will be evident if there are carbon deposits in the engine. With the detachable cylinder head type engines that are now offered on most automobiles that are sold in sufficiently great numbers to insure a wide distribution, repairmen have a great advantage in that knocking due to carbon deposits may be easily eliminated. To remove the cylinder head it is only necessary to disconnect the top hose connection leading to the radiator and to remove the cylinder head hold-down bolts. The head

detail regarding these essential operations at this time, except to mention that probably 75% of the knocking noises evident in automobile engines that have been used for a time can be attributed to carbon deposits.

A point that should be firmly impressed on the repairman is the proper method of replacing and tightening down the cylinder head retaining bolts. The Overland Company, which has built thousands of automobiles in which the block type of motor with removable cylinder head is used, have issued a cut showing the order in which the retaining nuts should be tightened to insure that no undue strain will be imposed upon the head casting or retaining studs. The diagram shown may be followed to advantage in replacing

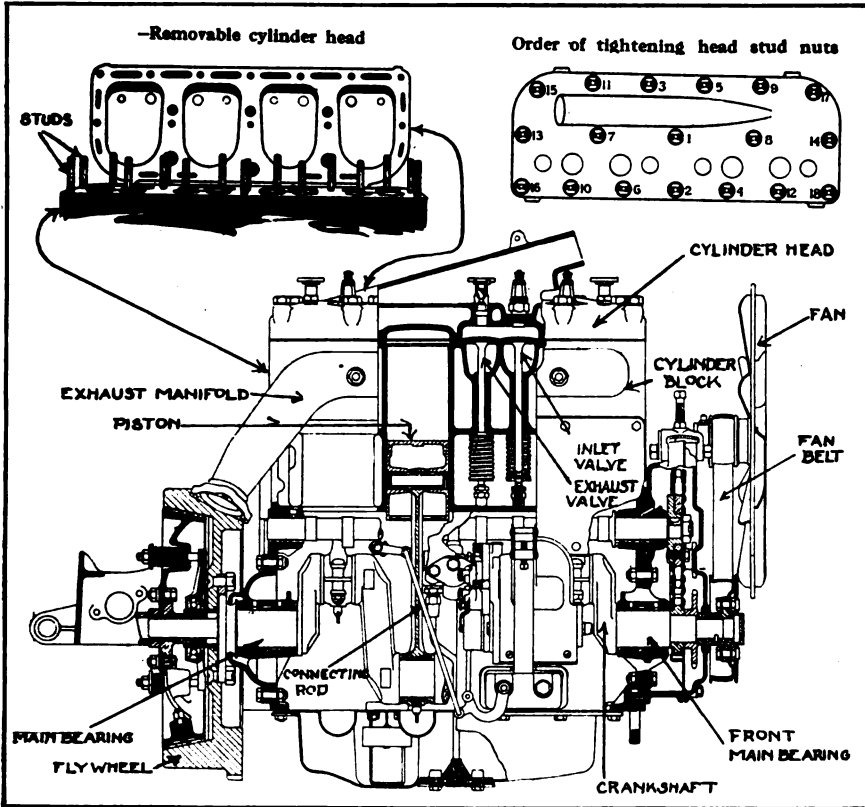

FIG. 2.—OVERLAND ENGINE HAS REMOVABLE CYLINDER HEAD PERMITTING EASY REMOVAL OF CARBON DEPOSIT

sult of this cooling influence, it will not expand as much as the exhaust valve which is exposed to flaming gas all the time it is open. The clearance should be more on an air-cooled engine valve than on those used to control the gas flow of a water-cooled engine. Similarly, an engine cooled by the thermo-syphon system, or natural circulation, will get hotter than one having pump circulation. The valve clearances should be correspondingly greater as the opportunities for expansion of the valves increase.

Defective lubrication produces squeaking or grinding noises. If the camshaft driving gear is loose on the shaft or if it has worn or broken teeth, a distinct metallic knock will be heard. This is due to the hammering action on the gear or its fastenings which result from the intermittent spring pressure of the valve springs first working to retard the camshaft movement and then to accelerate it. The bolts holding the cylinder in place on the crank case and those holding the engine base down to the vehicle frame in the case of an auto engine or to the foundation of the stationary engine, should be inspected to make sure that they are tight and that the parts they retain are held firmly. If the piston is worn to any extent or if the cylinder bore has become enlarged the piston will "side slap" in the cylinder which produces a dull pounding noise all the time the engine is running. Lost motion in the

of air in the gas mixture which causes slow burning of the charge.

The packings under the exhaust manifold sometimes crack or are lost. The exhaust gas will issue from these openings with a sharp hissing noise, very much louder than that due to the escape of gas around a leaky petcock or spark plug because a greater volume of the gas escapes. The muffler pipe sometimes becomes loosened at the point where it is attached to the exhaust manifold and the escaping gas at this point also produces a distressing whistle, especially on a multiple cylinder engine.

A rattling noise is usually evident when the valve action is worn. There are a number of points where depreciation may exist and very little lost motion in all of these may produce a sound that in the aggregate will be of considerable volume. If there is too much clearance between the valve tappets and the valve stems a rattling noise will be set up when the engine is operated at speed. The accompanying illustration, Fig. 3, shows the amount of space to be allowed on a Hudson, 6 cylinder engine. All engines do not have the same clearance. An engine that is well cooled and which uses small valves will run satisfactorily with a clearance of .003 inch (three one-

thousandths of an inch) whereas other engines with large valves that are not so well cooled may require as much as .005 inch to .007 inch. As a rule, exhaust valves need more clearance than inlet valves because they get hotter. An inlet valve is kept cooler by the passage of fresh gases from the carbureter. As a re-

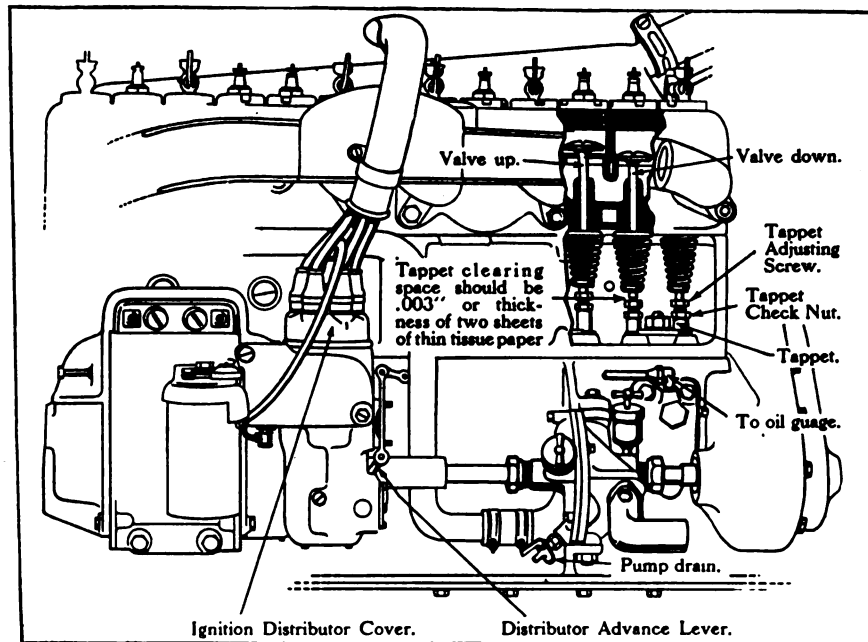

FIG. 3.—TOO MUCH CLEARANCE BETWEEN VALVE STEMS AND TAPPETS IS A FREQUENT CAUSE OF NOISE. HOW TO ADJUST HUDSON-SIX VALVE ACTION SHOWN



crank pin bearings, wrist pin bushings or main crankshaft bearings will cause a distinct metallic knock, whereas if the parts are not sufficiently lubricated the bearings will overheat and will indicate their distress by squeaking. If the bearing adjusting bolts, such as used at the crank pin end of the connecting rod or under the main bearings are loose there will be play in the bearings and pounding sounds will result. If the brasses or bushings in the lower portion of the connecting rod become worn so that the crank pin has some degree of play between them the engine will knock in a pronounced manner. On stationary engines crankpin-bearing adjusting bolts sometimes become loose which allows considerable lost motion between the crank and the box. This condition is easily remedied by taking up on the adjustment.

The flywheel is generally held to the crankshaft by means of a key in a taper shaft. In automobile work or by a series of bolts by which it is secured to a flange machined integrally with the crankshaft. It is seldom that a flywheel that has been properly installed on a taper shaft and which is held in place by substantial clamping nuts ever becomes loose. On stationary engines where the flywheel is usually of large diameter and often held in place on a straight shaft by a gib key it is apt to become loose, especially if the engine has been used for work where the power is needed intermittently and the drive taken from a rigid coupling formed integrally with the flywheel. A harsh acting tractor clutch is apt to result in loosening the engine flywheel if it is held by a simple key fastening. Engines used for stationary work, governed on the hit-or-miss principle, are also apt to develop loose flywheels. The flywheel of a single cylinder engine will loosen much quicker than that of a four-cylinder type because of the intermittent power application in the simple form. A loose flywheel produces a very pronounced knock which is often hard to locate and which is ascribed to a loose main bearing in most cases.

It is not difficult to take up bearing depreciation in stationary engines or auto types where shims are used between the bearing cap and seat and which may be removed to compensate for any lost motion that may exist. In a stationary engine with a wedge adjustment, as in the type shown in Fig. 1, the lock nuts

on the screw are released and this is turned in to force the wedge under the bearing and to bring the box carried by it into more intimate contact with the crankshaft. Connecting rod bearings are brought more closely together by removing the shims of thin metal that separate the bearing caps from the portion of the bearing attached to the lower end of the connecting rod, care being taken

of the large motors, it is necessary to employ a decompressor to facilitate starting. In some cases the decompressor arrangement may move over and keep the exhaust valve lifted. This results in weakened explosions and noise because of lack of power. If the camshaft bushings become worn or if the valve lift plungers loosen in their guides a light knocking noise will be heard.

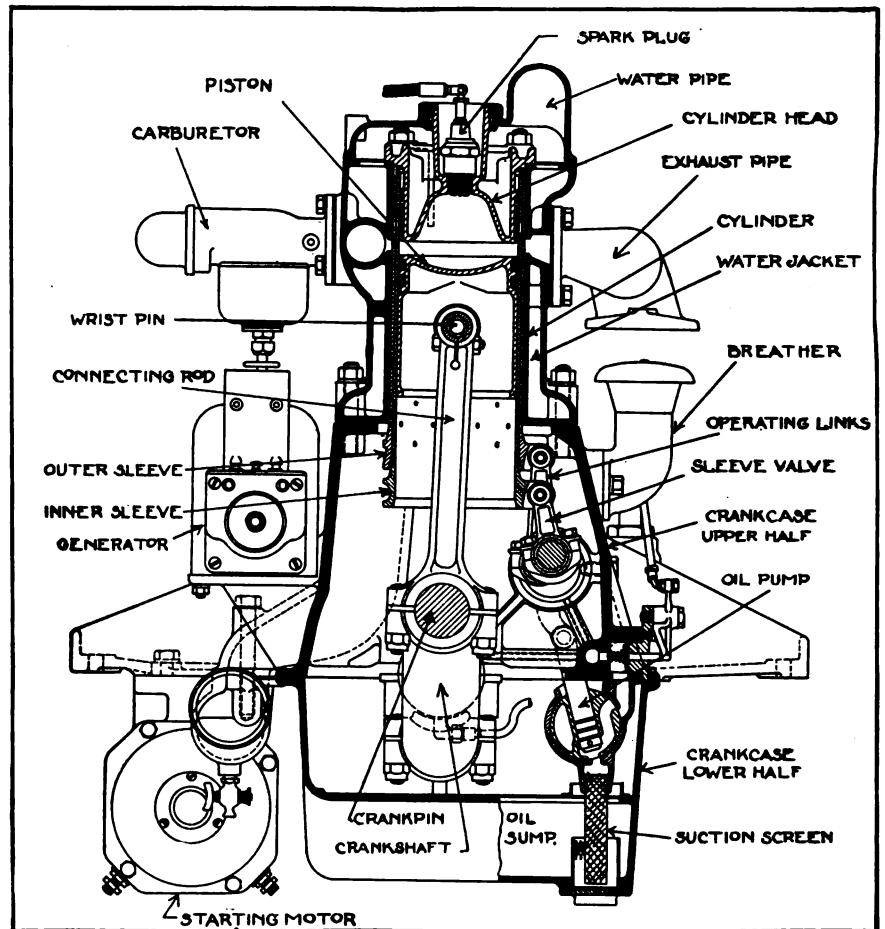

FIG. 4.—SECTIONAL VIEW OF THE WILLYS-KNIGHT SLEEVE VALVE MOTOR SHOWING IMPORTANT PARTS OF CYLINDER AND CRANK CASE

to remove only enough shims to take out the lost motion. After a time it is not possible to take up wear by removing shims, as it is necessary to scrape the bearings to a fit. This operation will be described in a separate article, as it is an important one with which every repair man should be familiar.

Whenever a sharp or unusual knocking sound is heard, the engine should be stopped immediately and careful inspection made to locate the cause of trouble. Irreparable harm may be done in a very few minutes if an engine is operated with a loose connecting rod or bearings that will be prevented by taking up the wear promptly by the adjusting means provided. In some

On some large engines the cams are keyed to the camshaft. After the engine has operated for a time these fastenings may become worn and also cause noise. The connecting rod big ends are the first points where lost motion will be evidenced. Next in order come the wrist pins and lastly the main bearings. The main bearings do not wear as quickly as the connecting rods because they have more area. A very rare cause of noise is a loose counter weight. These are securely bolted to the crank webs in all engines where they are employed but sometimes the fastenings may loosen from vibration and the resulting play between the counter weight and the crank shaft produces a hammering noise.



# TIMELY TALKS WITH OUR SUBSCRIBERS

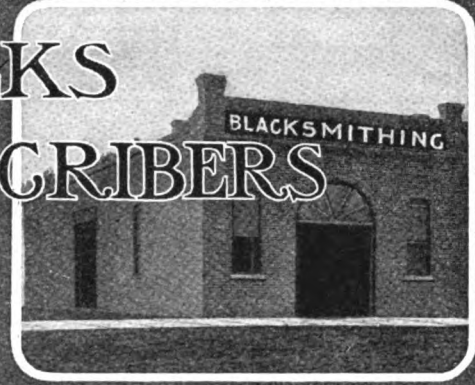

The American Blacksmith is published monthly at The New Sidway Building, Buffalo, N. Y., U. S. A., by The American Blacksmith Company. Incorporated under New York State Laws. Entered, February 12, 1902, as second-class mail matter at Buffalo, N. Y., Act of Congress, March 3, 1879.

William F. Wendt, President      Albert W. Bayard, Secretary      Walter O. Bernhardt, Editor  
 Associates: James Cran      Bert Hillyer      A. C. Gough      Dr. Jack Seiter

Subscription Price: \$1.00 per year in advance, prepaid to any postoffice in United States or Mexico. To Canada, \$1.25; other countries, 6 shillings. Reduced rates to clubs of five or more on application. See "Honor Roll" page for money-saving, long-time rates. Cable address, "Blacksmith," Buffalo. Lieber's Code used.

Subscribers should notify us promptly of non-receipt of paper or change of address. In the latter case it is necessary that you give us both the old and the new address.

### Know Your Costs

Never before in the history of the smithing craft has cost accounting been so important a matter as at present. Never before has it been so necessary that the practical blacksmith know what material, labor and time is costing him, as right now, when supplies and materials of all kinds have taken a skyward jump with prospects of continuing their upward travel for some time to come.

Of course, the average blacksmith knows what he is paying for supplies; he knows his cost to this extent, but—do you know what any given job is costing you? How much does it cost you, for example, to shoe a horse all around? In other words, how much money do you put into a job of shoeing from the time the horse enters the door-way until he goes out with four new shoes? And remember, everything that enters into that job of shoeing costs you money; your time, your labor and material all enter into the cost. On that basis of figuring, do you know the cost of shoeing a horse?

If you do not, how can you know whether or not you are making or losing money? It is by no means necessary that you have a set of complicated books, and an assortment of files, cabinets and cards in order to keep costs accurately. The particular methods you pursue in getting after cost records, is not so important as getting the actual results. What you want are actual cost records that will show you and tell you something. Keep track of the necessary figures and then use them. Carefully kept cost records will show you that you are most likely making considerably less money per job than you think you are. The cost of material, plus five cents for coal and two cents for light, will never give you a card of accurate selling prices. Carefully cost records will.

### Subscription Agents

When a stranger solicits your subscription to THE AMERICAN BLACKSMITH or any other publication, insist upon him showing you absolute proof that he is an agent in good standing and is employed by the publication which he represents. Don't, under any circumstances, give the man your money if you are not sure that he really works for the paper he says he does. No matter what the man offers you—no matter what price he makes—no matter what premium he promises to send—Don't Give Him Your Money if You Are Not Sure.

### Contents, January—1917

The Fable of the Rejuvenated Flivver Frontispiece .....	80
Treatment of Navicular Disease by Shoeing .....	81
The Movement of the Horse .....	82
Several Questions and Answers on Shoeing .....	82
Shoeing the Horse That Forges .....	84
Paying the Shoeing Bill With Farm Produce .....	84
An Oxy-Acetylene Welding Job With Profit .....	85
Cancelling a Sales Contract .....	85
Wrought Iron Gateway .....	86
Gas Engine Operation Made Simple—4 John W. Kiser .....	87
Thoughts on Timely Topics .....	89
The Smith In the Daily News .....	90
Blacksmith Works at Age of 98 .....	90
Honest Blacksmith True to Name .....	90
Blacksmiths Leave Fortunes .....	90
R. E. Lee, Blacksmith Congressman, Dead .....	90
Blacksmith Prices Take Jump .....	90
Bellows Bill (verse) .....	91
Heats, Sparks, Welds .....	91
Horseless Plows in Various Parts of the World .....	92-93
Our Honor Roll .....	94
The Machine and Tool Smith .....	95
The Tool Post and the Cutting Tool .....	95
Ways and Means of Finishing the Automobile .....	98
Benton's Recipe Book .....	98
An Excellent Anti-Rust Mixture .....	98
A Case Hardening Recipe .....	98
A Solution for Hardening Mill Picks .....	99
An Interesting Stunt .....	99
To True-up Oil Stones .....	99
Welding Spring Steel .....	99
The Lubricating Oil .....	99
An Iron Cement .....	99
A Paint Remover .....	99
Queries, Answers, Notes .....	99
A Tire Kink .....	99
Likes the Heat Treatment Articles .....	99
A Combination Plow .....	99
More About Whaling Tools .....	99
Runs a Molasses Mill .....	99
Cost of Living and Smithing Prices .....	99
Earnings and Prices .....	100
Calculating Stock .....	100
A Cracked Bell .....	100
A Missouri Price List .....	100
The Automobile Repairman .....	101
A Simple Oil Filter for the Auto shop .....	101
Repairing Clutch and Gear Set Troubles .....	101

### The Information Department

Are you making frequent use of the information department? If you are not, send in your puzzles. The information department is busy; they have been asked and have answered a great many questions during the past year. Lots of the questions have been published in the Queries, Answers and Notes Department. A great many of them have been answered by mail direct. The mail department of our information bureau has grown considerably in the past year. Our Correspondents, Contributors and Editors are at your service. Ask any questions on any topics connected with smithing, shoeing, vehicle work or automobile repairing, and our information staff will do their best to help you. This service is free of cost to our subscribers—all we ask is that you enclose a stamp if you want a reply by mail; if you can wait for the publication of your reply, you need not enclose a stamp. You can assist us very materially in our replies by stating your queries clearly and fully. Remember, when you ask a question, we have nothing to base our investigation upon except your letter. Therefore, tell us everything you can about what you wish to know. A question, carefully and intelligently asked, is half answered.

### PROFITS FROM THE ADVERTISEMENTS.

Are you making a profit by reading the advertisements in THE AMERICAN BLACKSMITH? The advertising pages will pay you a dividend if you will but read them in the right way.

The modern advertiser is no longer content to simply state that his wares are the best. He realizes that such statements mean little or nothing. He therefore gives you real, practical, worth-while information regarding his products. He tells you the how, the why and the wherefores, and then—he is ready to prove his statement—witness his free trial offer and his money back guarantee. They say something of interest and value to you, they tell you something and are worth reading. You cannot keep up with the times and with modern progress if you do not read the advertising pages in your trade journal. You are losing opportunities for profits and dividends if you do not read them.





**THE FABLE OF THE REJUVENATED FLIVVER.**

Once upon a time—very recently in fact, so to speak—a Wise Boy with a keen sense of values, who had long since cut his eye teeth and who could see into the future farther than yesterday, purchased a decrepit buzz-cart from a Misguided Individual who thought that because the wind-shield was grimy and because the tires were a little worn, that the Flivver was n. g.—in fact, on the way to the Dog Heaven. Mr. Wise Boy secured the Jitney for a song, and immediately began its Rejuvenation. He poured Air into the Tires and Gasoline into the Tank. He smeared Oil upon the Bearings and Polish upon the Fittings. He applied Paint and Varnish, and Tires and Tubes—he filled the Radiator and then the Seat, and—with a Push

on the Starter he proceeded to break records. He coursed down the Road of Progress like a Joy-rider with a Jag and two lady friends. He scattered consternation and money (in the shape of advertising) among the inhabitants and said: "Verily,—Worth dependeth not upon the number of Shekels needed to Procure, but upon what manner of thing you make of thy Purchase: Lo! the Has-been which was, has become an Efficiency Hound in my hands. Its Faded Grandeur has again become as the Brightness of the Morning. Its Jaded Ambish has become the very Essence of Peppermint and lo! and behold! I have made a Flivver of 1908 perform like a 1917 Fierce-Scarecrow and have gained a Recompeense."

And the name of the Wise Boy was Blacksmith and the name of the Flivver was Business.

Moral:—Which teaches us that a Failing Business is not bound for the Bow-wow's when Pep and Push are at the Helm.



# Treatment of Navicular Disease by Shoeing

PROF. HENRY ASMUS\*

I have devoted many years of my life to the horse shoeing trade and during this period have come in contact with many difficulties regarding the diseases of the horse's foot. Navicular disease in particular causes a great deal of trouble. During the past two years I have used a special method of shoeing with very good results.

It is not necessary to go into details concerning navicular disease as you are all familiar with it and its causes and that once contracted it is practically incurable. Much can be done, however, to allay the suffering of the horse by proper shoeing. Two-thirds of the cases of this disease, I believe, are caused by improperly dressing the foot, cutting the bars and frog away and thinning and weakening the sole. Also using a light, thin shoe and driving over uneven roads provokes inflammation of the tissues of the foot, which finally communicates itself to the bones and joints.

A hoof shows the effects of navicular disease by shrinkage of the outer walls upon the living parts of the foot immediately below the coronary band at the quarters. The cartilages are crowded in, circulation is restricted, the hoof becomes dry and hard, the wall thickened and high. When the disease is well established the horse manifests it by continual restlessness. One foot may be held back with heel elevated and toe touching the ground, or the toe may be twisted out with the heels resting on the coronet of the other hoof, or there may be constant shifting and flexing of the fetlock and knee.

In most cases one foot only is affected. The horse may go sound for a few weeks, then suddenly develop severe lameness that partially lessens with exercise. This is a sure indication that the physiological opening and closing of the heel, the hoof mechanism, is deranged. The derange-

\*Prof. Asmus is instructor in Horseshoeing at the Cornell Shoeing School, Cornell University, Ithaca, N. Y. He describes here the treatment presented by him before the N. Y. State Vet. Med. Soc.

ment of the normal hoof mechanism or folding and unfolding of the frog is the chief factor in the development of navicular disease.

The physiological movements of the hoof are as follows: the body weight falls from above upon the fetlock-joint, first, second and third phalanx, and the navicular bone. When the foot reaches the ground the weight is transmitted through the laminae to the wall. As the fetlock reaches its lowest point the third phalanx and navicular bone yield to the body weight, sinking downward and backward. At the same time the upper posterior portion of the second phalanx passes

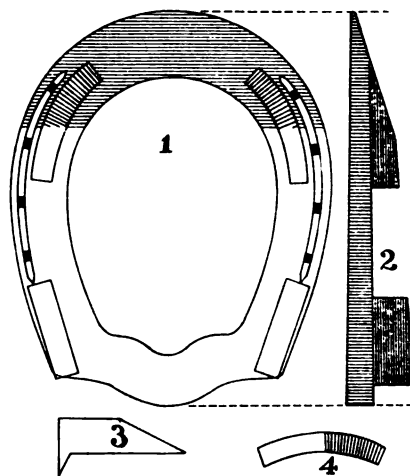

DETAILS OF THE SHOE USED BY  
PROF. ASMUS

backward and downward between the lateral cartilages which project above the upper border of the hoof wall. The perforans tendon is thus compressed upon the plantar cushion which expands laterally, pressing against the lateral cartilages; they in turn yield and expand the wall at the quarters. The resistance of the ground, or a bar-shoe with frog pressure, compresses the plantar surface of the frog, widens it, and crowds the bars apart. In this manner the quarters are expanded, especially at their plantar border.

These changes of form are more marked in the front feet than in the hind. In defective and diseased

hoofs it may happen that at the moment of greatest weight bearing, instead of an expansion, a contraction may occur at the plantar border of the quarters.

In the treatment of the disease my method of shoeing is as follows:

It is based upon the contraction of the outer wall upon the soft parts of the foot immediately below the coronary band. The cartilages are crowded in and the circulation restricted by incomplete expansion of the hoof, due to lack of frog support. In dressing the hoof the sole is made fairly thin, and the bearing surface of the wall leveled. Then with a hoof-rasp a groove is cut immediately below the coronary band; this groove is carried as far forward as the anterior border of the lateral cartilages (about two-thirds of the distance toward the center line of the hoof), extends through the horny wall, and includes a thinning of the wall below the coronet until it yields readily to thumb pressure. Below the groove the wall is rasped to the horny laminae to the extreme ends of the buttresses and bars on both sides of the hoof. The frog is left full so that the bearing surface of the frog and toe are in the same plane. After the hoof is dressed a bar shoe is applied. If calks are required two heel-calks and two toe-calks are used; the heel-calks are one and one-half inch long and three-fourths of an inch high; the toe-calks are about two inches long and one-half inch high. The posterior (heel) end of the toe-calk is placed on a line that equally divides the space between the second and third nail holes from the toe; follow the circle of the shoe around the toe inside the nail holes, so that the nails may be driven outside the toe-calk. Bevel the shoe from the center of the two toe-calks to a thin edge of the web at the toe; this provides a rolling motion.

In fitting the shoe place the bar as far back as possible; this will relieve direct pressure on the navicular bone. Place a thick piece of



sole-leather under the shoe, and pack the foot with pine tar and okum, or salt pork. A light blister at the coronary band may be beneficial. After a day or two put the horse to work. He may go lame for a few days, but gradually improves, and in a few weeks is much better.

Shoe in this manner for five or six months. The quarters are then grown down, and the frog pressure in conjunction with the free movement of the lateral cartilages has expanded the heel of the hoof. The navicular bone, perforans tendon, and plantar cushion now have more space for expansion; the coronary band can spread, and a wide heel is the result.

## The Movement of The Horse

E. H. MALOON

Since writing my previous article I have thought I would have done better if I had first told some of the beginners in horse shoeing how the bones, joints and tendons were placed in the horse's forward leg from the knee down, and how the joints were worked and the motions a horse makes to propel himself over the ground.

It is as follows; In Fig. 1, beginning at the knee we first have the cannon bone, A. Next comes the ankle joint with two sesamoid bones, B, at the rear. This joint connects the cannon bone, A, and the upper pastern bone, C, and brings us down to the next joint. This joint connects the upper (C) and lower pas-

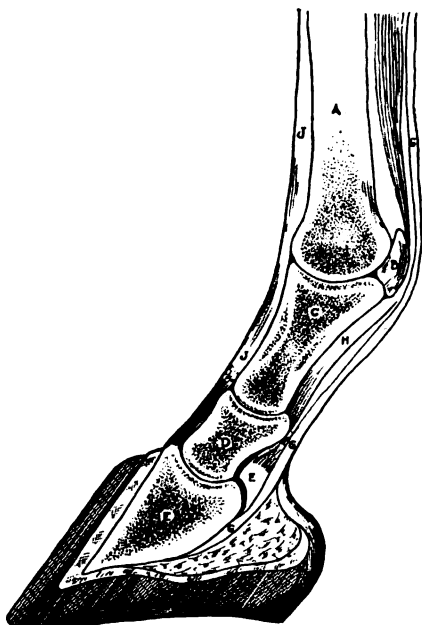

FIG. 1.—THE BONES AND TENDONS MENTIONED BY MR. MALOON

tern (D) bones. Then comes the navicular joint which joins the navicular bone, E, and the coffin bone, F, together.

The coffin bone is the last bone in the foot and is shaped like the hoof. Part of the navicular joint is a small bone (navicular bone) something like the sesamoid bones and lays right back or rather under this joint and acts as a fulcrum that the rear tendon plays over the same as the sesamoid bones.

There is a main tendon, G, that comes down over the sesamoid bones at the rear of the ankle joint and enters the foot under the navicular bone and is fastened at the bottom of the coffin bone. This tendon flexes the foot at the navicular and coronary joints. Another tendon comes down the rear of the leg and over the sesamoid bone, and spreads out and is fastened to the short pastern bone and flexes and ankle joint. Yet another tendon, I, comes down and is fastened at the front of the coffin bone. This tendon unfolds the foot so it can come to the ground level when the horse has reached the end of his stride.

These tendons run in sheaths. When a horse has become warm and is left facing the wind or out in the cold with no protection, these tendons become sore and inflamed and if not taken care of, they unite to the sheaths that they run in and the horse's gait is shortened up and his foot comes to the ground before the front tendon can get his foot level and he stumbles and wears off his toes.

I have in just a rough way described the bones, joints and tendons and we will now see if we can describe the motions that propel the horse forward.

Let the feet be described by the figures as shown in Fig. 2. When the horse wants to move, his first motion is to roll up onto the toe of No. 1. This foot doesn't leave the ground until his leg is past the centre or a little more than plumb and the foot and leg is very much as shown in Fig. 3. After No. 1 leaves the ground the main cord at the rear folds up his foot at the coronary joint. Then the second tendon at the rear folds it still more at the ankle joint. The foot then takes the stride, the front tendon unfolds the foot and pulls the toe up level and the foot comes to the ground. While all this has been going on, foot No. 2 has been going toward No. 3 and gets there just as No. 3 comes up on its toe to start ahead. (Right here

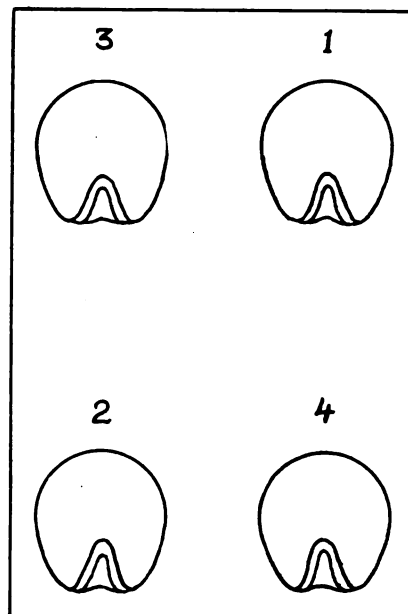

FIG. 2.—HOW THE HORSE USES HIS FEET TO MOVE OVER THE GROUND

is where the forging takes place) We left No. 1 foot way ahead and No. 2 foot up to No. 3. At this No. 1 is pulling and No. 2 is pushing to get the body ahead. Thus the horse is propelled over the ground, as this process repeats and as each group of movements follow each other rapidly.

## Several Questions and Answers on Shoeing

Editor's Note: The November number contained an article by J. R. West on "How I Built up my Shoeing Business." D. O. K. of California, has asked Mr. West several questions. Both the queries and the replies of Mr. West are given.

### The Questions

I have just read your very good article in THE AMERICAN BLACKSMITH on building up a tottering business. The same thing is happening to me just now. Have always had a good shoeing business until this fall, but it is cut down considerably. Of course, I have, in late years, made more of a study of lameness and the faulty gait of horses, but never advertised myself as a specialist in foot troubles. But since reading your article, the thought struck me that I might pick up quite a few more horses by so doing as there are quite a few lame horses around this country.

I see where you were healing a horse with contracted heels. Do you use a bar shoe with packing or a level edge shoe or springs or thin quarters or toe? I will give you my methods and if yours are any different and simpler, would you please let me know at some spare



time? I know well you think I have a great deal of nerve to ask such of a stranger whom I don't know. But when one is trying to learn, that is about all the good we can do one another anyway, so I would like to hear from you on these subjects.

Corns; my way is to keep pressure away and blister coronary to create a larger casing for feet. Also, the same way in quarter crack. I burn at hair and sometimes weaken quarters if wall is thick. In interfering front and hind, do you believe in cutting down the outside of toe-out feet and the reverse on the toe-in foot? Over-reaching; to build up heel in front and shorten toe with roll and long toe on hind foot. Stumbling, knuckling and knee sprung to build up heels and roll toe.

In drop sole, do you believe in convex shoe with pad or concave shoe with 4 calks on shoe? Laminitis or founder, bleed at toe, shoe with roll toe and usual packing. Spavin, for relief only, high heels and low toe calks rolled. Ring bone, for relief only, roller or rocker shoe that is high in center, thin heels and rolled toe. The same in side bone, only pressure, cut away under bone so as not to get any shoe bearing. Thrush, clean out all matter, bleed some and pack with salt and cover all with hot pine tar, oakum and pad.

Have you ever had any experience with canker? Is it best to burn and then pack? When a horse is pigeon-toed, do you believe in trying to straighten him much, as it may put too much bearing on outside of joints and foot, which will cause side bone in time, will it not? As a great many say, cut down the inside of foot in pigeon-toe and the outside in the toe-out horse. In contraction, do you find it best to let heel take bearing or do you cut away bearing entirely or half moon outside quarter, and let joint of heel take bearing, as so many have different ideas in this.

You speak in your article about salves or ointments; do you use them on foot only or in swelled ankles and tendons where there is not a veterinary in your section?

D. O. K., California.

**The Replies**

Friend O'Keefe, of California, has asked enough questions to require almost an entire book of replies. I will, however, try to reply to at least some of them, and to make my replies just as short as

possible, and still have them fairly complete.

My treatment for contracted heels depends a great deal upon the amount of the contraction. I use a beveled shoe, also shoe with lugs which project up on inside of each heel branch and then use tongs to spread the shoe at each treatment. I might remark in this connection that there are very few rules which can be followed implicitly in the treatment of a great majority of foot troubles. So very much de-



FIG. 3.—THE HORSE'S FOOT JUST BEFORE BEING RAISED OFF THE GROUND

pends upon the extent of the trouble, its age; that is, the length of time with which it has persisted; and naturally, the work and use to which the animal is put, must also be considered.

In reference to corns, there are a great many ways of treating them. I pare the hoof, relieving the pressure at the seat of the corn, pack foot with some good packing, and use a bar shoe. In quarter crack I relieve the pressure at shoe surface just below the crack, cut across the crack at an upper end in an effort to prevent its going farther, and do everything possible in order to promote the general health of the foot, using leather pad with packing and stimulating the growth of the horn, if this is found necessary. If the case of cracked hoof has been of long standing, I cut away the horn in the neighborhood of the crack as much as possible, and bandage the bared tissues with healing salve or ointment; bandage entire foot very carefully, using a protective shield if the horse is at all likely to strike the foot thus treated.

In treating for interfering, I usually try to pare the foot level and even, and to correct the trouble with properly weighted shoes. Sometimes, of course, this method is not suited to the case, and one must be guided accordingly. Your treatment for over-reaching, stumbling, knuckling and knee-sprung would, it appears to me, to be about right if you do not follow these methods too rigidly, particularly when other complications are found present with these troubles. For drop sole I use the bar shoe, which is shaped to fit the sole, calks being used to raise the sole off the ground. This, in my estimation, is about the only thing that you can do in a case of this kind, for at best, you can only make the horse usable. The other incurable troubles that you mentioned can only be treated with the same idea in mind.

In the case of canker of the foot, I do not recommend burning, if it is possible to treat the trouble by more humane methods. In your next case of canker, try the following: Clean the foot with warm bath and wash carefully with a carbolic solution. Remove all diseased portions of the horse carefully with a good sharp knife and with a sharp scissors, cut off all the ragged parts of the softer tissues. Pare the foot down just as much as possible and to prepare it for a plain shoe. After shoeing, place the foot in a bath for an hour or two; the bath of a solution of sulphate of iron, two ounces of the powdered sulphate to each gallon of cold water. When the foot is removed from the bath, pack the diseased portions of the foot with oakum, which has been dipped into a mixture made of Barbados tar, 1 part; of turpentine, 8 parts, to which mixture is slowly added two parts of sulphuric acid. This mixture should be well stirred and cooled. When using this, make up a small wad of oakum, dip it into the mixture and apply to the foot until all diseased parts of the foot are well covered with the oakum, when a pad of clean oakum is added in order to place considerable pressure over the parts. A piece of tin is then slipped in under the shoe to hold the pad in place. The whole foot should now be incased in a bag, which may be made of ordinary gunny sack and the horse should be turned loose in a dry box. The bag should be removed and the pad changed frequently, once a day is none too often, and when changing all pieces of horny matter must be



rubbed off and as the secretion diminishes with each new dressing, a dry powder, such as calomel, chloride of lime or sulphate of iron may be used. These should be mixed with powdered animal charcoal in the proportion of one of powder to about eight or ten parts of charcoal. Even after the tissues are all well covered with horn, it is a good idea to continue the treatment with a weak solution of a healing and antiseptic nature to prevent a recurrence of the disease.

I do not believe in trying to straighten the pigeon-toed horse's foot, but devote my attention rather to the correcting of his gait. In the treatment of contraction, the bearing or the relief of the bearing of the foot depends a great deal upon the extent of the contraction, and the length of time with which it has persisted. As you know in the case of extreme contraction where the frog has almost disappeared, it would be extreme folly to shoe such a foot with any considerable amount of shoe pressure as it most likely would produce complications which may actually be worse than the contraction itself.

As to the salves and ointments, these are used in all cases where they are found necessary, whether it is a foot trouble or a sore back.

J. R. West, New York.

## Shoeing the Horse That Forges

E. H. MALOON

In a forging horse I have found there is but one principle involved, and that is to quicken him up forward and retard him behind.

You doubtless know that the first move a horse makes when he starts to step is to roll up onto his toe. His toe does not leave the ground until his leg is forward of the centre. Now, the quicker you get him over the centre forward and the longer you can keep his hind foot on the ground, the less he will forge.

I do it like this: Forward I take a light shoe and draw the toe from the first nail holes, on a bevel, to a thin edge. This I roll up just a little. I next weld in heel calks and leave them  $\frac{3}{8}$ -inch at the end and taper them toward the toe. Behind, I lower the heel as low as safety will permit. I now take a medium heavy shoe, put on a toe calk,  $\frac{3}{8}$  inches high, and no heels. Sometimes I put on a low heel and a  $\frac{1}{2}$ -inch toe calk, as the needs of the horse may require.

Set the shoe over the foot so that the toe will be on a line with the wall of the foot. This, I determine with a short, straight edge. This kind of front shoe is a real benefit to the horse when he is at rest, as it takes the strain off his back tendons.

If you have a horse come in that stands high on the rump and low on the withers or has a short body and long legs, don't feel bad if you cannot help him as you certainly cannot rebuild him and if he goes seven miles or less per hour, you cannot change his gate. You can make him tarry a little behind and you can

potatoes would not only pay a shoeing bill of \$6.50, but would entitle him to seven dollars in actual money or in additional trade—IF—you have not raised your prices.

Or suppose we look at the situation in another way; while your farmer customer would need to bring in ten bushels of potatoes in order to pay his shoeing bill of \$6.50 last year, this year he will need to bring you less than five bushels to pay the same bill, and this brings to mind the question:—

How do you measure your dollars? By what you get for it or by what you give for it?

Tack This Up For Future Reference

# WELDING

## CUTTING--CARBON BURNING

Send Us Your Welding, Cutting and Carbon Burning

WE MAKE A SPECIALTY OF—Automobile Parts, Engines, Printing, Mill, Elevator, Ice, Laundry, Brewery, Farm, Hoisting, Electrical, Packing and other Machinery Parts, Boilers, Tanks and Sheet Metal. We cut Boilers, Tanks, Structural Steel, Scrap Steel, Wrecked Buildings and Bridges, Safes, Vaults and other Steel.

Work Guaranteed

Prices Reasonable

**S. J. PEMBERTON,**

Winchester, Kansas.

Phone 18.

THIS ADVERTISEMENT IS SENT OUT IN THE SHAPE OF A POST CARD

quicken him a little forward and a fraction of a second is all you want.

Years ago, there was a trotting stallion in this section. His driver knew that he could go fast if he could be made to pick up a little quicker. This he accomplished with a rolled toe shoe and the horse earned lots of money.

Out of this incident I perfected my theory of shoeing a forging horse and I used it some years before other smiths caught on.

## Paying the Shoeing Bill With Farm Produce

If your farmer customers paid you in farm produce, how would you fare?

One year ago, farmers were getting an average of \$.65 per bushel for potatoes; today the average price is a little over twice last year's figures, or in the neighborhood of \$1.35 per bushel. Suppose a farmer owes you a bill for shoeing of, say, \$6.50, and were going to pay you in potatoes. Last year he would have brought in ten bushels to settle his account; this year that same ten bushels of

Last year, for example, \$6.50 worth of shoeing was worth ten bushels of potatoes, or at the rate of 25-40 you would give your customer four sets of shoes all around, and two shoes reset. This year—unless you raised your prices—after giving your customer four sets of new shoes all around, and two shoes reset, you would receive less than four bushels, three pecks of potatoes.

Or suppose we take the matter in still another way: Suppose your farmer customer pays you in cash. He owes you the same bill of \$6.50 for shoeing, and after he pays you, you hand him back a dollar and tell him to bring in potatoes for that amount. Last year you would have received 1-2/3 bushels, this year he would give you but three pecks, consequently your dollar is worth less today than it was last year. It will not purchase as much, whether you wish to purchase the necessities of life, stock or equipment for your shop, or anything less that you may need.

And if you cannot purchase as much for your dollar, YOU CAN NOT GIVE AS MUCH FOR IT.



## An Oxy-acetylene Welding Job With Profit

S. J. PEMBERTON

In the accompanying engraving is shown a wheel before and after welding. The wheel weighs 400 pounds and is over four feet in diameter. It was welded in four places and completed in two hours from the time we started to pre-heat it until it was welded. The wheel cost originally \$20.00. We welded it for \$10.00 and got five dollars an hour. Our costs were about \$1.50 as near as we can figure. Is \$4.25 net, per hour, good pay or is it not? We saved our customer \$10.00 and probably thirty days of delay in getting a new wheel. We were tickled to death to get the job at the price.

If you think the welding machine is not the best machine the smith ever had in his shop, get out and talk to "the man who owns one," who is doing welding and making a success of the welding business. Everybody who buys a welder does not make a success out of the business. I have had jobs out of Atchison, Kansas, which is twenty-five miles north of me, that welders there had fallen down on. Don't think that by just buying a machine, and turning on the gas according to instructions, you can weld any thing that comes along. That is where you will fall down. I went to Kansas City, which is about 60 miles from me and did business with one

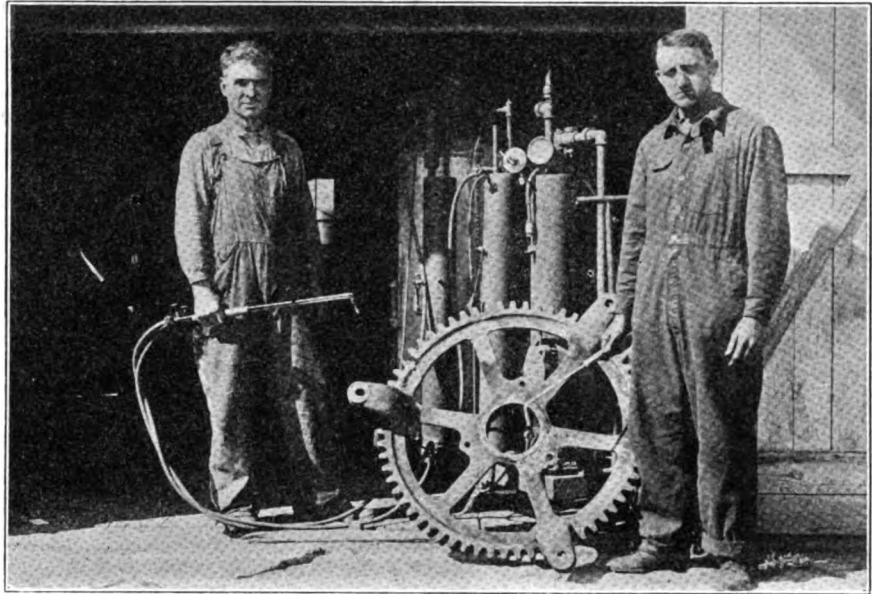

TWO HOURS LATER, WITH THE AID OF THE MACHINE IN THE BACKGROUND —AND EIGHT AND ONE-HALF DOLLARS DROPPED INTO THE TILL

of the best welders there. I bought a bill of supplies and got all the knowledge I could get. And I did not stop at that. I still go there for information if I get a job that looks difficult to me. I am not afraid of any job they can bring me and I would not take \$1000 for my welder if I could not get another. The welder is the coming thing and the blacksmith who does not get one will have to go out of business in a short time, as the man with the welder will force him out of business.

I am also sending you a card which I use to advertise my welding and cutting. This advertisement is printed on post cards.

### Cancelling a Sales Contract

Here is a case which gives a little different slant on the familiar case of the man who signs an order for goods without reading it, and afterwards finds that it calls for more goods than he thought he was ordering. The following letter comes to me from a Pennsylvania smith, evidently a newcomer in business.

A salesman for a certain wholesale company called on me early last December and wanted to sell me an order. I had only started in business at the time and was rather green in regard to buying. The goods he was selling was a side line to the business which I am in, but I told him I would take a small order. So he made me up an order and handed it to me to sign, which I did without looking it over. But that night I looked the duplicate order over and found that it was much larger than I could use and also much larger than I could pay for, as I had a very small business and no capital back of me.

So the following day I wrote the company asking them to cancel the order.

They wrote me back stating that they could not cancel the order for the reason that they had already paid the salesman his commission on same. I then wrote them again, saying that if they would cut the order down to about \$10 worth of goods I would take it, and if not I could not accept it.

The next I heard from them was a bill for the goods to the amount of \$30, stating that they were then shipping the goods.

When the goods arrived at the freight station I had the freight agent return them to the company, and I also wrote the company, stating that I had returned the goods.

Some time later I received a letter from a collection agency, asking for payment, which I ignored, and still later I received two more letters from two different attorneys asking for payment.

About two weeks ago the company sued me for the bill. The railroad company tells me that the goods were delivered.

Now I cannot afford to pay for that amount of goods that would be in my place for years before sold.

Please let me know what can be done.

I have not the goods at present nor never did have them in my possession.

This correspondent doesn't say explicitly whether the salesman tricked him, as he sees it, into signing a larger order than he thought. If, for instance, it was understood that the order to be given was for \$10, and the salesman made it out for \$30, then one situation would arise.

If on the other hand the order as the salesman made it up was exactly what the correspondent intended it to be, but sometime afterward he got to thinking it over and decided that he had overbought, then another and totally different situation would arise for consideration.

As both situations are interesting, consider the first one first. As I

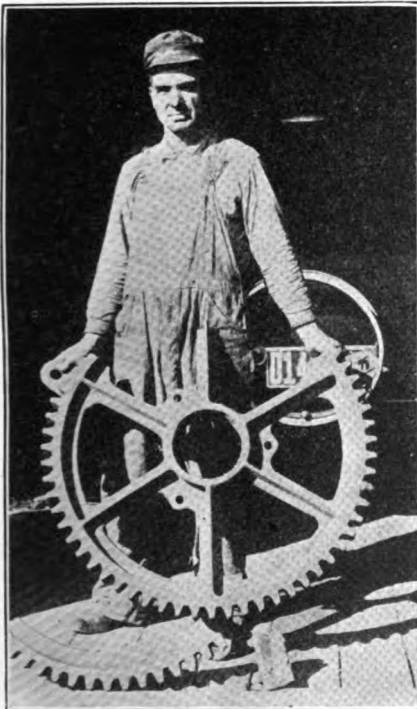

THE BROKEN WHEEL BEFORE WELDING



have pointed out before, there is an amazing amount of carelessness exhibited by business men of all grades in the matter of signing orders and contracts. Time and time again a paper which a buyer or a seller or a party to some contract signs, does not express what he wants it to. Occasionally this is due to fraud, but more often it is because it is not well drawn. But nevertheless, if the party who is deceived had a complete opportunity

when a salesman deliberately pads an order and openly hands it to the buyer to sign, believing that he will carelessly neglect to read it. That is a plain case of negligence on the part of the victim and what he got was coming to him.

So much for the first condition. Let me briefly discuss the second.

No buyer can deliberately and in full knowledge sign an order for merchandise, the order being upon some house that had never sold him

is green about buying. I will tell him how he can avoid such difficulties in the future, and this can also be read with profit by a great many buyers who are not green:—

1—Never order more goods than you know, after full consideration, that you want, for your signed order is a binding contract, and you may not be able to escape from it.

2—Never sign any paper, order, contract or what not, without first reading it slowly and carefully

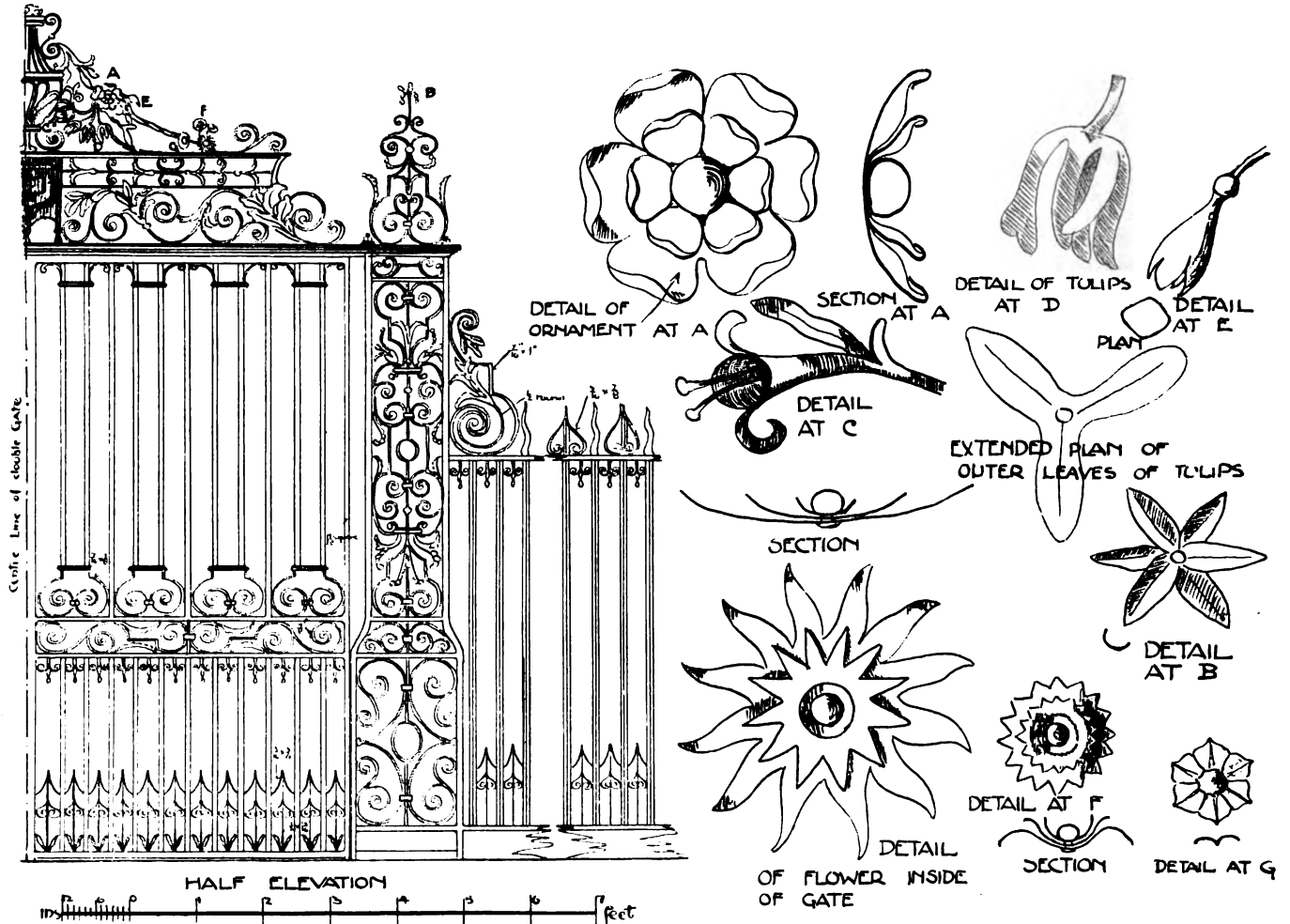

SKETCH OF GATE SHOWN ON PAGE 87 WITH DETAILS OF TOP ORNAMENTS SHOWING HOW THEY ARE CONSTRUCTED

to read it over before he signed it, and neglected that opportunity, and by reason of such neglect was let in for something, he cannot complain but must take his medicine. The law has very little time for the business man who signs a paper without reading it, and finds himself deceived in consequence.

There is really only one exception to this rule. If a salesman obtaining an order, or the other party to a contract, pads the order or alters the contract, and then by some subterfuge prevents the deceived party from reading it, the latter can escape on the ground of fraud. But there is no fraud in the eyes of the law

goods before, and then back out of it afterwards merely because he changed his mind. An order is a contract which binds both parties unless one party (the seller) has by a long course of dealing, led the buyer to believe that he could cancel an order any time he liked.

In the case submitted to me, there can hardly be but one ending to the suit. The minute this correspondent admits that he signed the order (if he was not tricked into doing it), judgment will be given against him for the claim itself, plus certain costs, to which must be added his attorney's fee.

This correspondent admits that he

twice and asking for an explanation if any part of it needs explanation. And if something is lacking which you think should be in, never take the other man's word. Insist that it go in the paper and don't sign it till it does.

(Copyright, 1916, by Elton J. Buckley.)

### Wrought Iron Gateway

The Virgin Chapel Porch, St. Mary's, Oxford.

JOHN Y. DUNLAP

The ornamental gateways which are so common in the districts of Cambridge and Oxford differ in many ways from the ironwork which



is found on the Continent. Still the local smiths of that district must have learned much from their craftsmen brethren abroad and although it may be said that the foreign craftsmen decorated his work for the artistic effect only, who knows but that it was from these foreign examples that the English blacksmith learned to consider the purpose for which his work was for in the first instance and to ornament it as far as possible afterwards.

In the gateway shown the double gate way is 9 feet and 6 inches wide

much on the same lines except in one case and of that I have given a drawing. In this particular case the flower is shown with long pointed shaped edging of a triangular form only after the bottom part has been cut out each of the sharp points seem to have been heated and set with a twist, so as to make this variegated edging appear to be of a wavy shape. The next row of petals are the same in number but straight, and the centre layer is a circle.

All those as shown in the section are rivetted together and to the

At E, the flower is more like a snow-drop on a large scale. This has evidently been forged conically, then the edge shaped and the stem inserted in position. The detail at F, is made up of three layers which have each been prepared separately and fitted together. G is a perfectly flat flower with six leaves, each of which have a sunken mid rid.

In every case the grouping and setting of the model blooms are very natural and their welding to the scrolls produce effects in ironwork which is very pleasing to the eye, artistically correct and have been strong enough to last through many years of a changeable climate.

### Gas Engine Operation Made Simple—4

The Purchase, Installation, Operation and Troubles of a Gas Engine.

J. L. HOBBS  
Lubrication

The grease cup system is very common and very efficient and gives splendid service in dusty and dirty places, and is very valuable on moving parts where no other system could be used, like shakers, crank bearings of small, rapid running engines, or any part where the oil hole is in motion at all times. This method is very simple and consists of two or three parts, a base which screws into the bearing to be lubricated, a cap which screws onto the base and a spring to aid in feeding the grease to the bearing. These cups should be thoroughly cleaned occasionally and should be kept free from grit or dirt. Great care should also be used to prevent the grease from coming in contact with any foreign substance before it is put into the grease cup. A little sand will cut a bearing awfully fast.

The time honored squirt can does not need any attention here, except that unless the outside of the bearing around the oil holes is kept clean it will really do more harm than good.

The splash system is coming into its own rapidly for the lubrication of the crank axle and all other moving parts which can be placed inside of the crank case, such as cam shaft, rollers, igniter trips, etc. The oil is poured into the crank case and is dipped up at each revolution of the crank and splashed over everything in the crank case, even to the piston and cylinder being sometimes oiled in this way.

There is a gauge or drain cock or

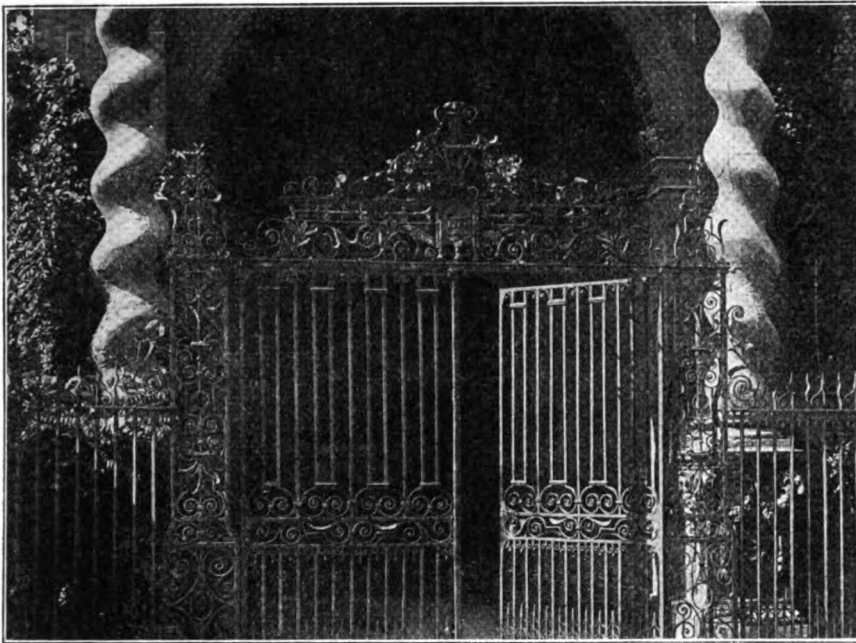

THE CHAPEL PORCH GATE AS IT STANDS—DETAILS SHOWN ON PAGE 86

at the lower part. The gates have a fixed grille above and with its ornamental piers at each side, is a fine example of English work.

The gates are of a very simple design and consists almost of vertical bars with a few small ornamental scrolls at their terminals. The piers are composed of scrolled panels in which the horizontal rails are brought in a line with those in the gates. The railings on each side extend along about 7 feet and at their junction with the gate piers have a bracket scroll support extending upwards.

In the fixed grille above the gates we have a few fine examples not only of scroll work but also of the floral art in wrought iron. A few of these I have shown in the enlarged sketches with the hope that they may be of some use to those of the readers who are interested in architectural ironwork. These decorations are not the same on both sides of the grille, still they are very

metal scroll on the top. In the ornament at A, the flower is built in three parts which consist of the outer and inner petals and the centre. Each layer of petals, after it has been cut to the outline appears to have had each part dumped up in the middle and the outer edge folded over. The inner layers are set to fit over the outer ones but have been treated in the same way.

At B, the flower is formed with six extended leaves. These have been shaped in groups of three and rivetted together. Each of the leaves have a sunken mid rib and are hollow in sections.

At C, the ornament is a bell flower. In this case the outer part of the bloom is forged hollow and at the junction with a stem a leaf protrudes.

The tulips at D are made from extended leaves as shown, two set for each flower, so that when they are set in a spherical shape a round section is obtained.





some other similar method of showing how much oil is in the crank case at all times. If it is not kept where the crank can reach it, the lubrication will fail, but if too much is supplied it will only run back into the bottom of the crank case and cause no trouble. The oil should be entirely removed from the crank case occasionally and new oil substituted in its place.

The object of this book is to give you the best methods of lubrication, that is the best way to get the most out of your lubrication system. The most important thing is to have clean oil, of course. A good way to secure this, where it is practical, is to have a filter, which can be bought or made that will entirely eliminate all foreign substances from the oil before placing it in your lubricating system. Some large users of oil filter every bit of new oil they buy before using it, and it is a splendid practice, as it takes away all possibility of trouble from this source.

A few words in regard to the different kinds of oil might come in well here. Never, under any circumstances, attempt to use a steam engine oil in a gas engine, as the two kinds of oil used for the two kinds of engines is very different. A gas engine requires a high fire test oil. The oil, to give perfect lubrication in the cylinder, where the heat sometimes gets up to several hundred degrees, must be one that will not burn. Steam engine oil will burn up and fail in a gas engine. It is only required to stand a temperature of about 300° degrees in a steam engine where in a gas engine it is sometimes required to stand three times that much heat.

An oil which will give perfect satisfaction in a gas engine using natural gas or gasoline for fuel might utterly fail in an engine using kerosene or any of the other less volatile oils as a fuel. The reason for this failure is that the kerosene burning engine produces almost twice as much heat as either the gas or gasoline engines.

A good plan to follow is to consult the manufacturer in regard to what oil is best adapted to your engine. They always have tabulated information to go by and can give you an oil which will work with a high degree of efficiency. The cost of the oil should be a secondary matter entirely, as oil is the cheapest thing an engine uses, a little extra expense on oil is not to be considered. Oil is much cheaper than bearings.

The writer received his most

valuable lesson in lubrication from the operator of an engine, who happened in this case to be also the owner of the engine. This engine was used in a meat market several hours

other and went over every part of that engine, with first the oily waste and then the dry, and cleaned it until it was as shiny as when new. He then took a wrench and went over



A SECTION OF THE GATEWAY TO THE GALLERY OF APOLLAN AT THE LOUVRE, PARIS. A TRIUMPH OF THE 16th CENTURY MASTER SMITH

per day, running meat grinders, cold storage machinery, electric lights, etc. When first seen this engine was about six years old and looked like new. The owner was asked how he kept his engine looking so well. He said: "I will show you in a few minutes just how it is done; I am about ready to stop it for the day." When he stopped the engine, he took a piece of oily waste in one hand and a piece of dry waste in the

every nut and examined every bearing, making the little adjustments he found necessary. This took him just 10 minutes and was the most valuable ten minutes he spent during the day. As a result of this kind of care, his engine was always absolutely free from dirt or dust, the bearings were in proper condition and the engine gave splendid satisfaction. He further gave the information that he never allowed anyone

else to handle the engine and by taking care of it in that way he always had perfect power and had been to no expense whatever for new parts, not even new piston rings. He also said: "When I am ready to start, I take an oil can in one hand and a piece of clean waste in the other and oil every part which needs oil, and then with the waste wipe all the surplus oil off, so that there is no oil for the dirt to stick to." This little conversation and operation took about 15 minutes and was the best spent time we remember of during our entire service in the gas engine work.

We have already given a pretty general idea as to the care an engine should receive so we will now proceed to the repair and explanation of some of the most important working parts.

For the proper repair of an engine it is necessary to have a number of good tools, kept up in good shape to work with. The manufacturer is generally pretty liberal with tools sent from the factory with the engine, but you will find use from time to time for some tool that the manufacturer did not include with his kit. A good engine operator will always have a good tool box with a key and lock so that the tools will be there when he wants them.

The bearings of an engine are made of some soft metal, so that the wear will be on the bearing and not on the axle. The reason for this is that the bearing can be replaced much easier at far less expense than the axle or working part. Several metals are adaptable to this use. Babbit metal, bronze, brass, and alloys of these metals and others are the bearing metals in general use.

Babbit metal is the most common, probably because it can be handled easier than the others. Anyone with good judgment and by using a little care to details can produce a good babbit bearing. The bearings of an engine are made in two ways. The larger and heavier bearings and the ones on which will be the most wear are generally made in two pieces, while the smaller and less apt to wear are made in one.

A one-piece babbit bearing is made as follows: Clean all the old babbit out of the bearing. Place the axle in exactly the position you wish it to run and fasten it securely. Coat the axle with laundry soap. Stop up both ends of the boxing with mud or any other substance which will not be affected by the heat of the molten metal. Place a

small piece of wood in the oil hole, allowing it to touch the axle, so that when it is removed an oil hole will be left in the bearing. When you are ready to run the bearing, apply enough heat to the boxing and shaft so that you cannot bear your hand on them, then heat the babbit metal so that it will scorch a piece of wood, then pour the opening entirely full of the babbit without stopping. Allow the babbit to cool. If your work has been a success you will be able to turn the axle in the bearing and by applying a little oil it will roll freely. If it appears tight it may be necessary to drive the axle out of the bearing and scrape out just a little of the metal until you have a perfect fit.

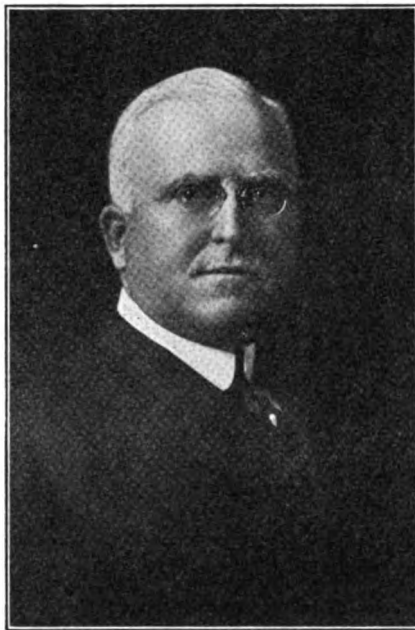

MR. JOHN W. KISER, LATE PRESIDENT PHOENIX HORSESHOE COMPANY

### John W. Kiser

John W. Kiser, president of the Phoenix Horseshoe Co., and known on two continents as "The Horseshoe King," died on October 31st, at the Blackstone Hotel, Chicago, after a long illness.

Mr. Kiser was 58 years old. He was born on June 20, 1858, at St. Paris, Ohio. He was graduated from Wittenberg College, Springfield, Ohio, in 1884, and in the same year, married Miss Phirza W. Furrow, of St. Paris.

When Mr. Kiser left his home in St. Paris, Ohio, he had his way to make in the world. Going to Chicago, he began with a sewing machine company. He kept his eyes open for the big opportunity that he knew would come, and it did

come when the great demand for bicycles caused the development of the great bicycle industry.

Mr. Kiser organized the Monarch Bicycle Manufacturing Co., and made it one of the strongest concerns in the field. Then he sold his interest and turned his attention to the manufacture of horseshoes. The Phoenix Company already had been formed by John W. Miller. It had a plant at Poughkeepsie, N. Y. Mr. Miller was later succeeded in the business by his son, Elishua H. Miller. When Mr. Kiser entered the company, a second plant was built at Joliet, Ill. The company is now capitalized at three million dollars and Mr. Kiser held practically all of the stock.

In addition to being the chief executive of one of the largest horseshoe manufacturing businesses in the world, Mr. Kiser was also interested in many other enterprises, and was a director in the First National Bank of Chicago and The Miehle Printing Press Company.

The story of Mr. Kiser's life links the farm with the romance of big city business. It is the story of the rise of the poor farmer to that of a captain of industry. Mr. Kiser went to Chicago in 1889 with practically no funds, but with the energy of a young farmer and the brains of a captain of industry, and by taking advantage of the opportunities that confronted him and working hard, he amassed a great fortune and built a great business.

### Thoughts on Timely Topics

By THORNTON

#### Caustic Censure and Cheery Comment

What are the relative values of a steer and a man? We read a most interesting article the other day that took that thought as its key note. And naturally, having written, spoken, preached and argued on the same subject off and on for the past nineteen years, the article struck us right at home. As the article said—we have our Bureau of Animal Industry that looks after the cattle interests. And when, as happened several years ago, a human case of the foot and mouth disease was discovered, the Bureau of Animal Industries sent one of its experts to investigate the case to see that it was properly quarantined and that the *cattle interests* were safe. As a well known doctor working for the public health put the matter:—"I dream of the day when we shall be called to Washington to see if the *people* are safe." And so we come



back to the original question—the relative values of the steer and the man. Let us not disregard the importance of the health of the cattle but—let us give a bit more time and attention to the raising of “blue ribbon” girls and boys. Let us pause in our consuming endeavor to get a gold medal for the hog, chick and steer, and raise a gold medal man or woman from that thousand dollar girl or boy. The folks who have made a study of the matter tell me that the average cost of raising a boy from birth to the age of production is one thousand dollars. Aside from his being a thinking, reasoning human, he is worth considerably more in dollars and cents than any hog, chick or steer.

Shoeing was the subject and the misguided plow-follower that brought up the subject tried to cross-examine me into admitting that shoeing “was a necessary evil”. There never was a necessary evil, as far as I have been able to figure out during my few years on God’s earth and certainly shoeing is no exception. Just because the wearing of shoes has brought corns and callouses to the human foot is no reason why we should go back to the foot-wear of Adam and Eve. Can you imagine it? It’s not shoeless feet that we want, but properly shod feet. And that refers to horses as well as humans. You know there are more points of contact between the shoeing of humans and the shoeing of horses than most people generally think. The shoe for a horse should fit his foot just as the shoe for the “two legged animal.” And just as there is little that will more quickly transform an even-tempered, mild-mannered man into a cantankerous, back-biting individual than a pair of tight, corn-pinching shoes, so will a set of ill-fitting iron crescents that are slapped on by a near-sighted, corner-visiting shoer transform a sweet-spirited family mare into a veritable fiend bent upon self-destruction and murder. You can no more expect a horse’s foot to be properly fitted by a bibulous, hay-brained individual, whose nearest approach to shoeing apprenticeship was gained in cutting soil-channels for vitrified pipe lines, than you can expect comfort from shoes fitted to your own feet by a wrist-watched, cigarette smoking nonentity who is shifted from “ribbons”, to “silks” and from “hose” to “powder puffs” as the trade of the store demands. There’s considerably more to shoeing the foot of the horse than simply

taking down a size that “looks” as though it ought to be right. But of course there are and always will be misguided yaps who think that the shoer is a grafter and that shoeing is simply an expense that has to be met.

Far be it from us to rattle the skeleton, as it were, but d’y’ ’member how the parcel post was goin’ t’ bring the high cost o’ living to earth before we had parcel post? Looks now as though the cost of living was using parcel post in its trip to the moon.

## The Smith in The Daily News

### BLACKSMITH WORKS AT AGE OF 98

If John Hatfield, blacksmith at Hatfield, a “corners”, three miles south of Corning, Ohio, lives until Feb. 17, he will be 99.

Hatfield does not believe in a man retiring from active work at the early age of 99 and says he is going to keep on as long as he can. He lives with his daughter-in-law, Mrs. Charles Hatfield.

Good teeth and perfect digestion are what maintain his vitality, he says. He has always lived an out-door life. When a mere youth of 90 he commenced to smoke. He weighs 130 and sleeps ten hours a night.

### Honest Blacksmith True to Name

An honest man has been found in Marion, Ohio, and he’s a blacksmith. Jesse B. Walker, (blacksmith,) appeared at the county auditor’s office and asked if it was too late to put him on the tax duplicate for \$800 which he said his wife had forgot to list for taxation. He was accommodated.

### Blacksmiths Leave Fortunes

Mid Joyner, aged 48, for many years a successful blacksmith of Jackson, Tenn., died at his home. He amassed the sum of \$25,000 or \$30,000. He leaves a widow and one child.

An estate, valued at \$36,000, was left by James Cullen, of Rochester, N. Y. Mr. Cullen conducted a blacksmithing shop for a number of years. William H. Cullen, a son, was given letters of administration on the estate yesterday by Acting Surrogate Barhite. He will share the estate with two other sons.

### R. E. Lee, Blacksmith Congressman, Dead.

Robert E. Lee, ex-Congressman and Democratic leader, died at his home in this city, after an illness of six months. He was first elected to Congress in 1910, and was re-elected by nearly 5,000 majority in 1912, at a time when his advocacy of a greater port for Philadelphia, and a 17000-foot dry dock at League Island, as attracting national attention.

Robert E. Lee was born in Pottsville, Penn., October 12, 1868. His father died when he was only seven years of age, and he began life by selling newspapers in order to aid his widowed mother. Later on, he was apprenticed as a blacksmith and

learned this occupation thoroughly. He was never ashamed of this humble origin, and nothing pleased him better, at the height of his career in Congress, than to be referred to as “the blacksmith Congressman.”

Eight years after learning the blacksmith trade Lee entered into a partnership with his brother, Luke, and the grocery store they established has since become one of the leading mercantile establishments of Pottsville.

### Blacksmith Prices Take Jump

Blacksmiths of Globe and Miami, Arizona, have formed an organization and have elected officers. The need for securing better prices for their work made the move for organization, necessary.

Blacksmithing firms in Lexington and Fayette county, Kentucky, numbering twenty-five, have made a general raise of 20 per cent. in prices of horseshoeing and all repair work on account of the advanced cost of material.

At a meeting of the blacksmiths and horseshoers of Salt Lake county, it was decided to increase the price of horseshoeing 25 cents. The raise is to be put in force immediately.

The men present formed an Association of Blacksmiths and Horseshoers of Salt Lake county. The officers elected were Andrew Worley, president; R. R. Palmer, of Taylorsville, secretary, and Briggs Smith, of Murray, treasurer.

Owing to the high cost of living, as well as of everything that enters into their work, the blacksmiths of Fremont county have agreed to an advance in the price of horseshoeing. The price is raised 10 cents for old shoes and 15 cents for new ones. This raise is effective at once and includes all the smiths in the county.

The Winchester (Mass.) blacksmiths have organized with the Woburn smiths, the first step of the new association being to raise the list of prices for their work. This has been done all along the line.

Forty proprietors of blacksmith shops in Louisville, Kentucky, met at the shop of William Lamb, Seventh and Congress streets, and there formed a temporary organization of horseshoers for the purpose of increasing their prices proportionately, they say, with the increased cost of materials necessary to their trade.

It is planned to make the organization permanent, elect officers and adopt a complete new and uniform price scale. Prices now vary at different shops. The average charge for shoeing a horse, that is all four feet, is \$1.40. It is said the promoters of the association propose to make the new price for this service from \$1.60 to \$1.75.

In justification of the movement they point out that horseshoes have advanced from \$3.75 to \$5.55 per hundred pounds; nails, \$3.20 per twenty-five pounds; calks, from 80 cents to \$1.90 per twenty-five pounds; and wagon tires from \$1.40 a hundred pounds to \$3.90; and that the smiths in every city in the country are advancing the prices, those of Cincinnati now getting \$2.25 for shoeing a horse.



## Bellows Bill

OTTO WAGNER

Down on the corner, 'neath the hill,  
There was a smith named Bellows Bill,  
He kept a shop there all his life,  
And kept a farm for sons and wife  
To work and toil and hoe and rub,  
To keep the smith in rags and grub.

All day long he'd work and fuse,  
And then sit down and read the news.  
And all night long he'd sleep and snore,  
Then read some more about the war.

He knew his trade from A to Z,  
And so he said: "Now, don't you see,  
I do not have to read along,  
The line o' things I learn'd when young."  
He knew his prices all by heart,  
He knew them, too, right from the start.  
He'd make a price, then knock off half,  
I think, to make his customer laugh.  
And so it was with Bellows Bill,  
He always sure did eat his fill.

He lived and laffed and cussed and swore,  
Took out his plug and cussed some more.  
And 'till he reached the land eternal,  
He never read a Blacksmith's Journal.

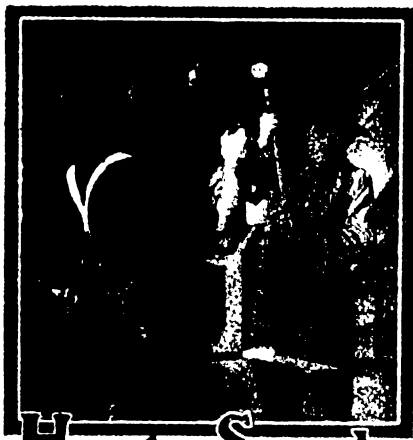

## Heats, Sparks, Welds

Talking of profit—it is also possible to make a profit in buying.

When does your insurance contract expire? Don't wait until after the fire to find out.

One thing that keeps success from more men's doors than any other, is hard work.

What can possibly keep success from your doors, if you have good brains, good material and good tools?

Your business will stand driving and it will surprise you what a lot of driving it will stand without balking.

Did you ever realize that the smith shop keeps the smith in about the same style that the smith keeps the shop?

How much is a fifty dollar kit of tools worth in the hands of a man with about twenty-three cents worth of knowledge and experience?

If you are trying to build up a reputation for fair and square dealings, don't cut prices. A reputation for fairness and honest prices go hand in hand.

The opinion of some so-called smiths to the contrary, notwithstanding, there's a whole lot more to smithing than simply heating the metal, and pounding it on the anvil.

Wonder what our friend, Tom Tardy's

been doing? He says "It's easier to lose ten dollars trying to fill a straight flush than it is to earn ten cents at shoeing horses."

You'll not be working for a dead beat when a good customer wants you, if you don't trust the people you can't trust. Get your money in advance from the doubtful payers.

Competition is said to be the life of trade, but, when your competitor gets so far ahead of you that you can't see him without the aid of field glasses there is not very much competition to talk about.

Never before in the history of the craft was it so necessary to mix real brains with muscle, in order to win the things that are really worth having. Mere brawn is not winning the laurels of the day.

When in doubt they will tell you where to buy what—so keep your catalogues where you can get at them when you want them. When you fail to file a catalogue, you fail to file a book of valuable trade information.

Yes or no—what is your reply when an automobile owner asks if you can fix his machine? Lots and lots of our readers are turning the autoists misfortunes into profit. Are you taking advantage of this opportunity?

Do you know your selling prices intimately? Don't be content with a mere passing acquaintance. A selling price is made up of two parts—the cost and the profit. Be sure that you are thoroughly acquainted with both.

The next time work is slack, try the telephone. Some merchants call up considerable business in this way. There is no reason why the smith can't do the same thing. See if you can call up enough jobs to keep you busy, the next time you find things slack.

The best time to teach a man in the way he should go, is when he's a boy, and the best time to present your bill is when it is young. It is difficult to teach an old dog new tricks as it is to collect an old, long-overdue bill. Get after them while they're young.

Whom do you suppose gets the most out of a good craft idea—the man who locks it away in the far recess of his brain, or the chap who not only makes use of it himself, but gives it to the smithing craft as well? There is a great big moral to this, figure it out.

If you can't show something on the profit side of the ledger, investigate. Don't be content with just making expenses. There must be something wrong if you can't show some return for your efforts, your investment, your time and trouble. Nothing will discover what is wrong quicker than prying into things generally.

Get out once in a while and look around you, it will do you good to see how and what other smiths are doing. The smith who stays in his shop all of the time never knows what is going on outside, and then too, is very likely to become narrow and grow to the inside of his shop.

The smith who hasn't time to read a good craft journal, is in the same class as the man who hasn't time to care for his health. When a smith thinks his nightly visit with the boys at the corner booze emporium is worth more than a good knowledge of his trade, he had best quit right away.

Once upon a time there was a blacksmith who succeeded in business and ac-

cumulated an exceedingly large pile of simoleons—and he never read a craft paper. But that was in the long ago before craft papers were printed and when all a smith needed to know was how to pump a bellows.

You can no more expect one advertisement to revolutionize your business, than you can expect to heat a piece of steel red hot with a match. It requires a real fire to heat steel, just as it requires real advertising to build a business. Better not to advertise at all, unless you can advertise correctly.

Are you looking after your equipment properly? Carelessness will wear out more tools than actual use. But then there's another extreme — that of attempting to patch up equipment already worn out. There's no economy in that. Buy good tools and give them good care, but when they are worn out get new ones.

The recipe for success in smithing calls for equal parts of experience, correct reading and brains—mix thoroughly and use freely. Twenty-four hours a day at the anvil won't teach you all you need know about smithing if you don't use your head correctly, and read what others are doing. Anyone will guarantee the above mixture to draw success to your door and stare you in the face.

We've just heard of another poor chap who failed to read a paper before he signed it. It's not wise to take a stranger's word for fact. Carefully read all papers before signing them. When the consideration is of any amount, better let your lawyer read them too. If a stranger gave you a sealed envelope and you hand him the ten dollar bill he asked said it contained a fifty-dollar bill, would you for? No, of course, you wouldn't, you would want to examine the contents of that envelope first. Yet some men will sign there names to papers without reading them, and often they would get off cheaper by handing a ten dollar bill right over to the man who asks them to sign. Better read the paper carefully first, it may take you some little time, but that time may mean considerable money.

What is your dollar worth? Can you buy as much with it as you give for it? The real worth of the dollar is determined by its purchasing power. How do you measure your dollar? By what you get for it or by what you give for it? A couple of centuries ago when the earlier settlers exchanged what they had for what they wanted, sheep entered into the majority of transactions in many sections as the medium of exchange. A sheep would, for example, buy so much flour or corn or sugar or salt or anything else that was needed. The value of a medium of exchange is determined by what you can get for it. For example, if at one time you got one hundred pounds of flour for one sheep and in six months or a year later you got but seventy-five pounds of the same kind of flour for the same kind of sheep, sheep will have lessened in value. A few years ago you could purchase ten pounds of beef or pork for one dollar, today you can get only four and one-half pounds of the same meat for that same dollar, consequently the dollar is worth less today than it was a few years ago. You cannot give as much for it. If you still continue to charge the same old prices and think you are making the same old profit, you are greatly mistaken. You cannot stay in business long on that system.

HORSELESS PLOWS IN VARIOUS  
PARTS OF THE WORLD

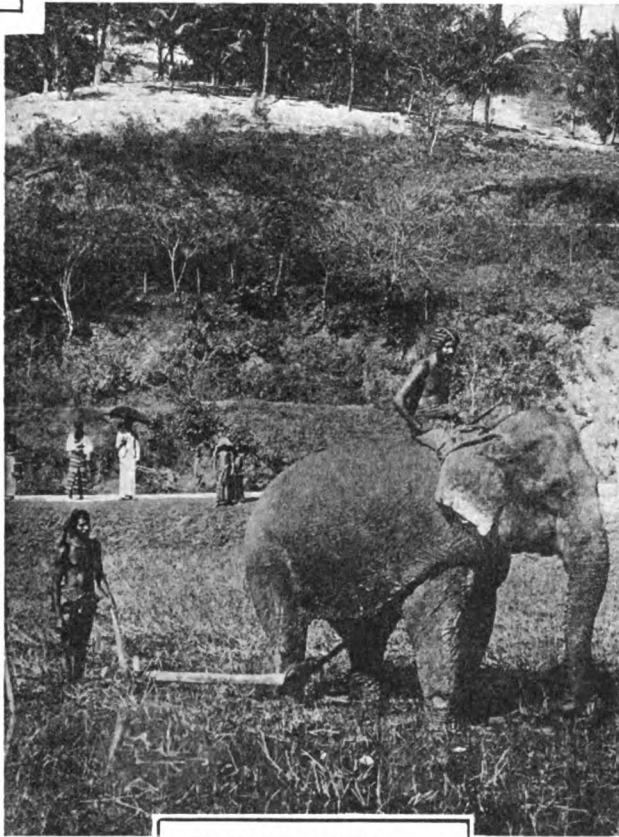

IN CEYLON THE ELE-  
PHANT IS USED TO  
PULL THE PLOW

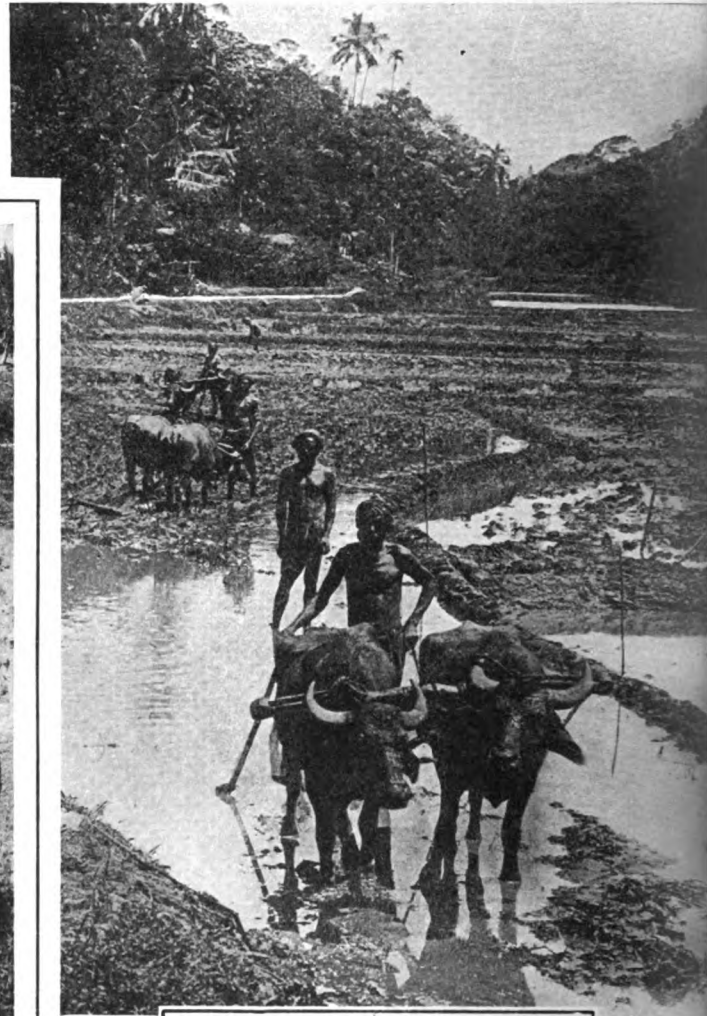

PLOWING A RICE FIELD WITH  
NATIVE ANIMALS IN CEYLON

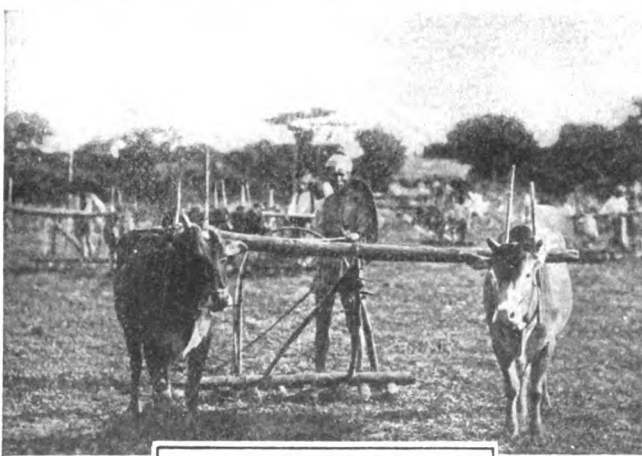

PRIMITIVE PLOW AND  
METHODS STILL IN USE  
IN BURMA.

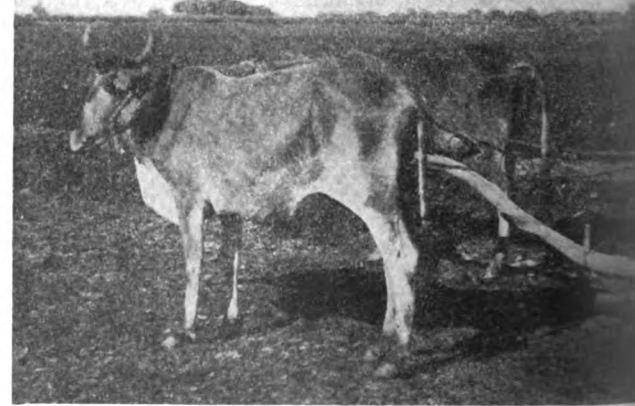

OXEN DRAW THIS PRIMITIVE PLOW IN

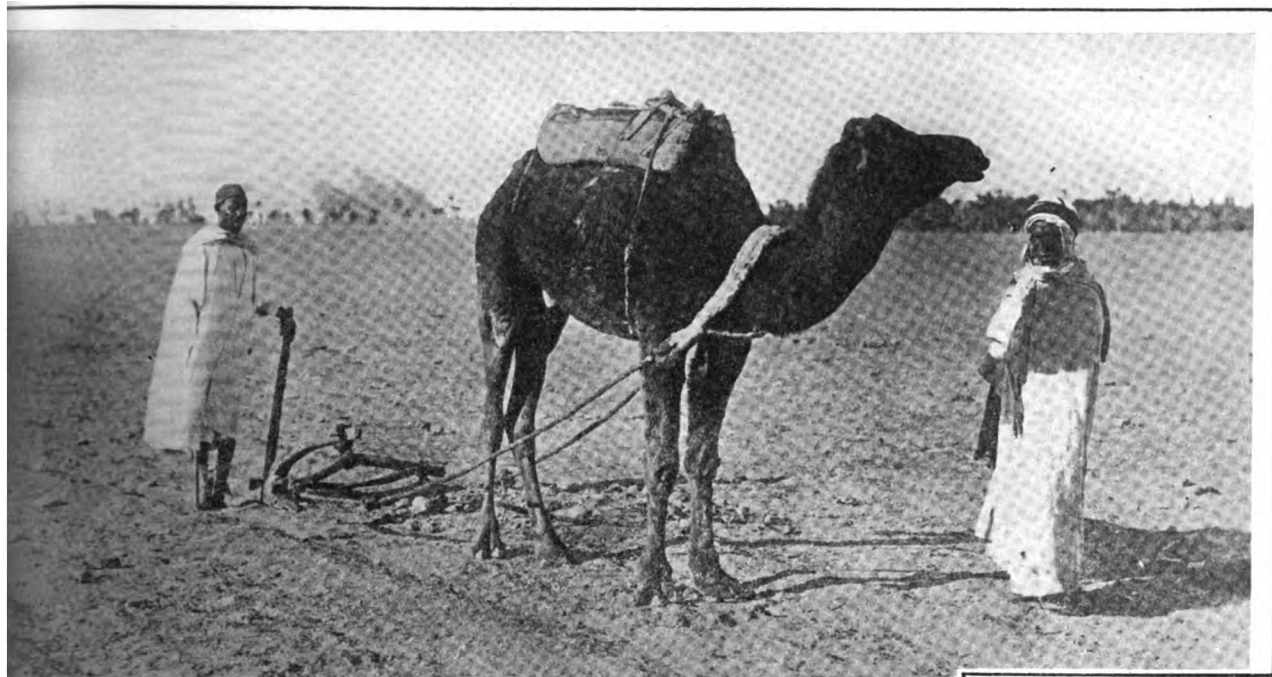

IN THE VALLEY OF THE NILE  
THE CAMEL IS USED



OXEN AND BUFFALO ARE  
USED IN THE HILLY  
GROUNDS OF PERSIA

THE ZEBU IS THE PREFER-  
RED DRAFT ANIMAL IN IN-  
DIA. THE PAIR HERE SHOWN  
ARE DRAWING A MODERN  
DISC HARROW

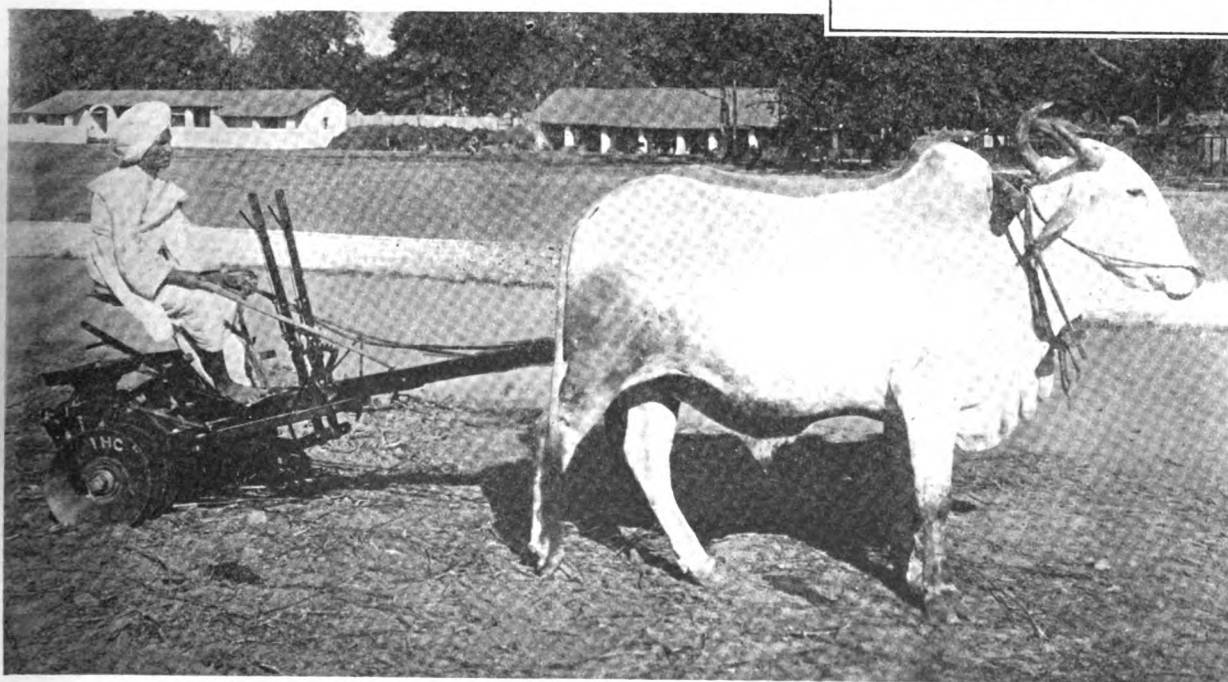



# Our Honor Roll

**IT'S EASY NOW TO BE AMONG THE LEADERS.**  
 Do you want to place your name among the leaders? It's easy now. If your subscription expires with the January, 1917, number, send in a little five spot (\$7.00 in Canada or 12 1/4 sh. in other countries) and your name will be placed in the January, 1917, class and you won't need to think about your subscription account for years to come. There are only a few subscribers whose subscriptions are paid up to 1917. Put your name in that group. It's easy if your subscription expires this month—January, 1917. If it doesn't expire this month, ask the Subscription Department when it does expire and how you can get into the leaders' class.

**A NEW NAME IN FIRST PLACE?**  
 The Fix-It Shop has held first place for some months, but we understand some one is planning to take the lead. A twenty-year order will clinch the lead for some one. Who will it be? Watch out for a new name in first place. Something's going to happen soon. Keep your eye on this Roll of Honor.

U. S. and Mexico		Canada		Other Countries.	
2 yrs.....	\$1.60 save \$ .40.....	\$2.00 save \$ .50.....	10 sh. save 2 sh		
3 yrs.....	2.00 save 1.00.....	2.70 save 1.05.....	14 sh. save 4 sh.		
4 yrs.....	2.50 save 1.50.....	3.20 save 1.80.....	18 sh. save 6 sh.		
5 yrs.....	3.00 save 2.00.....	3.75 save 2.50.....	1 £ save 10 sh.		
10 yrs.....	5.00 save 5.00.....	7.00 save 5.50.....	1 £ 14 sh. save 1 £ 6 sh.		

Send your order and remittance now—today. Don't wait until you forget all about it. You'll never regret it. Our subscription insurance saves you money. The sooner you begin saving, the more you save. There is no better time than NOW.

NAME	Subscription Paid to
The Fix-It Shop, Utah.....	July, 1915
J. A. Torray, Mass.....	Dec., 1913
W. C. Watt, Kansas.....	Dec., 1910
I. J. Stites, N. Y.....	Jan., 1919
Waddington Farm, W. Va.....	Mar., 1918
W. W. Egly, Pa.....	June, 1917
E. A. Krebbel, Kan.....	May, 1917
A. A. McLean, Nev.....	Feb., 1917
C. M. Adams, Conn.....	Jan., 1917
Plateau Shoeing Shop, Colo.....	Dec., 1916
C. J. Hale, Wash.....	Dec., 1916
John H. Schneider, Cal.....	Dec., 1916
F. L. Matlocks, Ark.....	Sept., 1916
E. B. Jones, Wisc.....	Sept., 1916
J. Taylor, Calif.....	Oct., 1916
J. Clarke, Jr., Queens, Aust.....	Aug., 1916
J. A. Buchner, Mich.....	July, 1916
H. Mitchell, N. Y.....	July, 1916
M. Broton, N. D.....	June, 1916
A. Schmitt, Neb.....	June, 1916
D. Ackland & Son, Man.....	May, 1916
H. Pilret, Ore.....	May, 1916
J. Sinclair, W. Australia.....	May, 1916
F. Sowa, Oregon.....	May, 1916
E. P. Digan, S. Australia.....	Apr., 1916
F. A. Peterson, Iowa.....	Apr., 1916
G. F. Bowers, Okla.....	Apr., 1916
W. Pocheu, Oregon.....	Mar., 1916
A. Garver, Ohio.....	Feb., 1916
C. Burton, Mass.....	Mar., 1916
J. F. Murphy, Nev.....	Jan., 1916
F. Kearnes, Illinois.....	Jan., 1916
J. N. McIntire, Pa.....	Jan., 1916
W. Post, N. Y.....	Jan., 1916
Powell Brothers & Whitaker, Eng-land.....	Jan., 1916
O. Temple, Idaho.....	Jan., 1916
N. Karolewicz, S. Dak.....	Jan., 1916
E. L. Lain, N. Y.....	Dec., 1915
J. A. Hulvey, Illinois.....	Dec., 1915
Williams & Turner, W. Va.....	Dec., 1915
J. J. Devine, N. J.....	Dec., 1915
P. Nelson, Minn.....	Dec., 1915
M. Kennedy, Tas., Australia.....	Dec., 1915
A. J. Wassmuth, Idaho.....	Nov., 1915
J. G. H. Mallett, Queens, Australia.....	Nov., 1915
A. W. Speir, Ohio.....	Nov., 1915
W. R. Clepper, Texas.....	Nov., 1915
G. H. Laley, Mass.....	Nov., 1915
L. Krause, Ind.....	Oct., 1915
Reynolds Brothers, Pa.....	Sept., 1915
F. W. Krens, Calif.....	Aug., 1915
C. E. Allen, Neb.....	Aug., 1915
A. E. Spangberg, Oregon.....	May, 1915
D. M. Kille, Okla.....	Apr., 1915
G. Gullgren, Iowa.....	Apr., 1915
G. Fredericks, Minn.....	Mar., 1915
V. Priessnitz, Wisc.....	Mar., 1915
E. Price, Illinois.....	Feb., 1915
D. C. Garber, Ohio.....	Feb., 1915
J. H. Kurt, Illinois.....	Feb., 1915
E. R. Hiteahue, Ohio.....	Feb., 1915
H. F. Schreiber, Pa.....	Feb., 1915
J. S. Damm, Iowa.....	Jan., 1915
J. M. Withers, Hawaii.....	Jan., 1915
N. B. Quick, Pa.....	Dec., 1914
F. H. Jarvis, Indiana.....	Dec., 1914
George Tatum, Jr., Fla.....	Dec., 1914
L. Clark, Va.....	Dec., 1914
A. N. Estes, Va.....	Dec., 1914
J. Bailey, Manitoba.....	Dec., 1914
E. G. Naylor, Md.....	Dec., 1914
Halvorsen Brothers, S. D.....	Nov., 1914
F. Schicka, Washington.....	Nov., 1914
H. E. Snyder, Oregon.....	Nov., 1914
J. A. Stewart, Ky.....	Oct., 1914
C. Richenecker, N. Y.....	Oct., 1914
W. L. Berthoff, N. J.....	Oct., 1914

NAME	Subscription Paid to
J. W. Hewson, S. Africa.....	Sept., 1914
Ed. Larson, N. D.....	Sept., 1914
R. T. Monk, Illinois.....	Sept., 1914
W. T. De Young, Illinois.....	Sept., 1914
C. W. Taylor, Pa.....	Aug., 1914
Charles Wells, Colorado.....	Aug., 1914
H. G. Weaver, Pa.....	Aug., 1914
Working Men's College, Vict.....	June, 1914
F. M. Kenoyer, Neb.....	June, 1914
O. Anderson, Ariz.....	May, 1914
R. C. Frederick, N. D.....	May, 1914
H. L. Fenton, New Mexico.....	May, 1914
J. Carl, Iowa.....	May, 1914
J. E. Little, Pa.....	May, 1914
H. I. Brenale, N. Y.....	Apr., 1914
W. E. Parr, Iowa.....	Apr., 1914
F. Sramek, Neb.....	Apr., 1914
L. A. Hulsen, Calif.....	Apr., 1914
J. E. Ray, Minn.....	Mar., 1914
A. Hulstrand, N. D.....	Mar., 1914
W. F. Biske, Wisc.....	Mar., 1914
F. F. Seibert, Calif.....	Mar., 1914
H. Roschewitzer, Mo.....	Mar., 1914
W. B. Eriant, N. J.....	Mar., 1914
A. Bosch, N. Y.....	Mar., 1914
D. Van Valkenburg, Mass.....	Feb., 1914
A. R. Johnson, R. I.....	Feb., 1914
F. Jacobs, Ohio.....	Feb., 1914
A. J. Ferry, Illinois.....	Jan., 1914
E. K. Walker, Calif.....	Jan., 1914
H. D. Erskine, Vermont.....	Jan., 1914
E. Fowler, Pa.....	Jan., 1914
Breen & Son, Ireland.....	Dec., 1913
M. Lamoreaux, Ohio.....	Dec., 1913
C. R. Davis, N. Y.....	Dec., 1913
F. W. Copeland, Kansas.....	Dec., 1913
J. L. Tomlin, Kansas.....	Dec., 1913
H. A. Davis, N. Y.....	Dec., 1913
E. H. Troyke, Illinois.....	Dec., 1913
D. B. Johnson, Iowa.....	Dec., 1913
S. Horton, Calif.....	Nov., 1913
J. Spratt, Mass.....	Nov., 1913
F. Watkins, N. H.....	Nov., 1913
F. Koppala, Ala.....	Nov., 1913
Y. C. Llenert, S. Australia.....	Oct., 1913
W. B. Abell, N. Y.....	Oct., 1913
W. R. Turner, Man.....	Oct., 1913
A. J. Brookman & Co., Vict., Aust.....	Sept., 1913
C. Nelson, Neb.....	Sept., 1913
H. M. Anderfuren, Calif.....	Aug., 1913
Camp Brothers, Texas.....	Aug., 1913
L. C. Larson, Iowa.....	July, 1913
S. Effenan, South Africa.....	July, 1913
G. L. DeWitt, Mont.....	July, 1913
W. W. Gregg, Texas.....	July, 1913
W. R. Stroupe, N. C.....	July, 1913
O. C. Young, Michigan.....	June, 1913
Otto Sippel, Pa.....	June, 1913
A. Chapman, N. Y.....	June, 1913
C. Birely, Md.....	June, 1913
F. H. Shupe, Pa.....	June, 1913
J. C. Stover, Pa.....	Apr., 1913
W. Schoonover, Pa.....	Apr., 1913
J. M. Rumire, Iowa.....	May, 1913
Lovinsdale Brothers, Mo.....	Mar., 1913
J. Carswell, Ark.....	Mar., 1913
G. E. Glazier, Ohio.....	Mar., 1913
F. Gath & Co., S. Africa.....	Mar., 1913
T. Bradley, N. S. Wales.....	Mar., 1913
L. T. Needham, Illinois.....	Feb., 1913
G. C. Disinger, Miss.....	Feb., 1913
J. Hughes, Ohio.....	Feb., 1913
J. Wieser, Minn.....	Jan., 1913
Z. A. Enos, Minn.....	Jan., 1913
F. G. Wise, Calif.....	Jan., 1913
F. S. Bishop, South Africa.....	Jan., 1913
J. Curran, Arizona.....	Jan., 1913
S. P. Harney, Mont.....	Dec., 1912

NAME	Subscription Paid to
W. Breckner, Okla.....	Dec., 1912
J. Pabina, Neb.....	Dec., 1912
P. Frederickson, Iowa.....	Nov., 1912
L. O. Leura, Illinois.....	Nov., 1912
W. Lawson, New Zealand.....	Nov., 1912
W. O. Grant, Calif.....	Oct., 1912
W. H. Miller, Iowa.....	Oct., 1912
J. S. Lee, Wash.....	Sept., 1912
A. O. Martin, Idaho.....	Sept., 1912
O. A. Mortimer, Idaho.....	Sept., 1912
H. J. Hyatt, Washington.....	Sept., 1912
J. N. Skow, Iowa.....	Sept., 1912
A. D. Standford, Washington.....	Sept., 1912
T. Temkiewics, Quebec.....	Sept., 1912
A. Palfier, Ohio.....	Aug., 1912
W. D. Valentine, Iowa.....	Aug., 1912
G. Hoffman, N. Y.....	July, 1912
J. Erman, Ark.....	July, 1912
W. K. W. Hansen, Pa.....	June, 1912
Robert Tochter, Calif.....	June, 1912
F. Van Marter, N. Y.....	June, 1912
J. Norrie, Yukon Ty.....	Jan., 1912
E. Anders & Son, S. Australia.....	May, 1912
Louisa Carriage Works, Va.....	May, 1912
S. Smith, Texas.....	Apr., 1912
J. W. Haar, La.....	Mar., 1912
D. W. Smith, La.....	Mar., 1912
D. W. Smith, Rhode Island.....	Mar., 1912
E. A. Dillon, Nev.....	Mar., 1912
D. F. Kuster, Washington.....	Mar., 1912
G. F. Johnson, Michigan.....	Feb., 1912
R. H. Keith, Iowa.....	Jan., 1912
J. Ingvarson, Minn.....	Dec., 1911
A. F. Mildebrandt, Mich.....	Dec., 1911
J. H. Trufel, Jr., Ill.....	Dec., 1911
R. C. Brown, Mo.....	Dec., 1911
C. Beyer, N. D.....	Dec., 1911
G. Nichols, Okla.....	Dec., 1911
F. H. Joslin, Mass.....	Dec., 1911
J. B. Scheidler, Indiana.....	Dec., 1911
J. H. Ickes, Pa.....	Dec., 1911
E. Willis, Colorado.....	Dec., 1911
J. Delane, Neb.....	Nov., 1911
W. Knouff, Ala.....	Oct., 1911
O. M. Johnson, Miss.....	Oct., 1911
J. K. Glinicki, Mich.....	Sept., 1911
H. Feldus, Neb.....	Sept., 1911
R. Murray, Calif.....	Sept., 1911
A. Hammond, Calif.....	Sept., 1911
P. Wedel, Kans.....	Sept., 1911
A. Harper, Mont.....	Aug., 1911
L. E. Bonton.....	Aug., 1911
J. Watson, S. Africa.....	July, 1911
R. Goldschagg, S. Afr.....	July, 1911
C. Hammerstram, Minn.....	July, 1911
A. S. Pratt, New York.....	July, 1911
E. H. Spain, Ariz.....	July, 1911
W. Urquhart, New Zealand.....	June, 1911
J. Koch, N. J.....	June, 1911
W. Voigt, S. Afr.....	June, 1911
J. M. Werl, Pa.....	June, 1911
G. Johnson, Kans.....	May, 1911
S. Budds, New Guinea.....	May, 1911
H. Baker, Aust.....	May, 1911
F. E. Smith, Vermont.....	May, 1911
A. J. Hatch, Maine.....	May, 1911
W. Cornwell, Pa.....	May, 1911
W. F. Kline, Kansas.....	May, 1911
J. Kirkbride, N. J.....	May, 1911
T. Holloway, Kans.....	Apr., 1911
W. Winget, Vt.....	Apr., 1911
J. A. Johnson, N. D.....	Apr., 1911
D. H. Laird, N. Y.....	Apr., 1911
A. J. Prue, N. Y.....	Apr., 1911
C. A. Butler, Ohio.....	Apr., 1911
E. Mossner, Queens, Australia.....	Apr., 1911
J. T. Rehm & Son, N. Y.....	Mar., 1911
W. C. LeBow, Mo.....	Mar., 1911
William Pate, Mo.....	Mar., 1911
A. T. Jameson, Colorado.....	Mar., 1911
C. Alexander, N. Y.....	Mar., 1911
J. Fencel, Wisc.....	Mar., 1911
H. Cornils, Oregon.....	Mar., 1911
C. Schmid, Neb.....	Mar., 1911
J. Schwarzmann, D. C.....	Mar., 1911
M. Stettner, Minn.....	Mar., 1911
F. Canfield, N. Y.....	Feb., 1911
C. Knudson, Iowa.....	Feb., 1911
S. Button, Kans.....	Feb., 1911
N. F. Hartsoe, Mo.....	Feb., 1911
I. Oepfle, N. Y.....	Feb., 1911
R. E. Worlington, N. Y.....	Feb., 1911
B. E. Doggett, Kansas.....	Feb., 1911
Shellhaas & Fry, Colorado.....	Feb., 1911
J. Tooes, Kansas.....	Feb., 1911
J. W. Wilson, Mo.....	Feb., 1911
W. T. Wilson, Indiana.....	Feb., 1911
J. Schmid, Neb.....	Feb., 1911
E. Sise, New York.....	Feb., 1911
A. R. Sterritt, New York.....	Feb., 1911
W. H. Starkey, Kans.....	Feb., 1911
W. Singleton, Pa.....	Feb., 1911
C. P. Van Vessen, N. J.....	Jan., 1911
J. Briere, Vt.....	Jan., 1911
A. Bartlett, Vt.....	Jan., 1911
E. H. Manley, Mo.....	Jan., 1911
Neufeld & Giesbrecht, Kans.....	Jan., 1911
G. C. Abbott, Ohio.....	Jan., 1911
Feldmeyer & Schaake, Mo.....	Jan., 1911
A. Josephelt, Colorado.....	Jan., 1911
C. L. McNail, Mo.....	Jan., 1911
A. Turley, Kansas.....	Jan., 1911
A. Seidel, Neb.....	Jan., 1911

NAME	Subscription Paid to
W. Ruple, Pa.....	Jan., 1911
N. A. Englund, Iowa.....	Jan., 1911
O. Gerhardtstein, Ohio.....	Jan., 1911
W. C. Rutter, Illinois.....	Jan., 1911
J. L. Jester, Mo.....	Jan., 1911
G. A. Moffat, Yukon Ty.....	Jan., 1911
J. W. Ivis, Utah.....	Dec., 1910
O. A. Huff, Pa.....	Dec., 1910
J. T. Rowe, Iowa.....	Dec., 1910
W. Parsons, Ontario.....	Dec., 1910
Eisler Brothers, S. Dak.....	Dec., 1910
J. Krahulec, Illinois.....	Dec., 1910
L. F. Keilhois, Pa.....	Dec., 1910
F. Markgraf, Minn.....	Dec., 1910
S. Wright, New York.....	Dec., 1910
T. P. Consodine, Mass.....	Dec., 1910
J. D. Fox, Neb.....	Dec., 1910
W. Treener, Washington.....	Dec., 1910
A. G. Palmquist Minn.....	Dec., 1910
J. E. Richards, Pa.....	Dec., 1910
J. Berthelsen, N. S. W. Aust.....	Dec., 1910
D. Coders, Illinois.....	Nov., 1910
C. Fransen, New York.....	Nov., 1910
J. Delane, Neb.....	Nov., 1910
J. H. Staats, Mo.....	Nov., 1910
George F. Wardle, S. D.....	Nov., 1910
H. C. Strine, Pa.....	Nov., 1910
C. M. McNutt, Mass.....	Nov., 1910
J. M. Mapes, New York.....	Nov., 1910
W. Condon, New York.....	Nov., 1910
F. Strief, Wis.....	Nov., 1910
L. P. Mortensen, Michigan.....	Nov., 1910
A. W. Brenneeman, Indiana.....	Nov., 1910
R. L. Whitfield, N. S. W. Aust.....	Nov., 1910
McFarlane & Pratt, S. Africa.....	Oct., 1910
Thomas Scurr, New Zealand.....	Oct., 1910
W. H. Finlay, New Zealand.....	Oct., 1910
J. Hawn, N. J.....	Sept., 1910
C. L. Massey, Ark.....	Sept., 1910
J. Jordan, Cal.....	Sept., 1910
J. Jordan, Cal.....	Sept., 1910
L. O. Brea, Washington.....	Sept., 1910
R. F. Simkins, Penna.....	Sept., 1910
A. E. Beeve, Mass.....	Sept., 1910
L. R. Garvin, Ohio.....	Sept., 1910
G. W. Phillips, Utah.....	Aug., 1910
T. Chittenden, New Zealand.....	July, 1910
O. Smith, Pa.....	July, 1910
F. A. Poole, South Africa.....	July, 1910
C. Gibson, Ill.....	July, 1910
H. M. Whitman, Neb.....	July, 1910
The Goldfield Diamond Drilling Co., Victoria, Australia.....	July, 1910
G. M. Robben, Kans.....	July, 1910
R. J. J. Rees, S. Australia.....	July, 1910
A. C. Morrell, N. B.....	June, 1910
G. Moran, N. Y.....	June, 1910
H. Fast, Man., Can.....	June, 1910
L. Underhill, California.....	June, 1910
F. Felts, Ohio.....	June, 1910
W. M. Puryear, Ala.....	June, 1910
W. L. Patterson, Okla.....	June, 1910
D. Hardy, Vict.....	June, 1910
E. Malpas, S. Australia.....	June, 1910
A. J. Hamburg, Ohio.....	June, 1910
C. M. Holton, Okla.....	June, 1910
C. L. Graf, Ohio.....	June, 1910
A. Mellum, N. D.....	May, 1910
N. Cobb, Wis.....	May, 1910
O. Houser, N. Y.....	May, 1910
A. Donahue, N. Y.....	May, 1910
J. A. Schmits, N. D.....	May, 1910
P. Wright, Calif.....	May, 1910
J. Stell, N. Y.....	Apr., 1910
F. Greer, Queens.....	Apr., 1910
C. L. Morman, N. Y.....	Apr., 1910
H. W. Fuhrock, Ill.....	Apr., 1910
A. Stephens, Queensland, Aust.....	Apr., 1910
Alex. Zimmer, Ont.....	Apr., 1910
C. P. Hardy, Neb.....	Mar., 1910
Rockenschub & Son, La.....	Mar., 1910
J. Weber, N. Y.....	Mar., 1910
Clark Bros., Cal.....	Mar., 1910
J. Hiernens, Minn.....	Mar., 1910
W. H. Leonard, Penn.....	Mar., 1910
G. S. Akers, Va.....	Mar., 1910
F. White, N. Y.....	Feb., 1910
H. L. Place, S. Australia.....	Mar., 1910
Ed. Grimm, Tex.....	Mar., 1910
J. H. Wilder, Penna.....	Feb., 1910
W. Nagowitz, Wisc.....	Feb., 1910
J. F. Lais, N. J.....	Feb., 1910
C. M. Jacobsen, Utah.....	Feb., 1910
C. M. Jacobson, Penna.....	Feb., 1910
I. Blough, Pa.....	Feb., 1910
Hope Bros., B. C.....	Feb., 1910
A. Standley, Ohio.....	Jan., 1910
F. Eiter, N. Y.....	Jan., 1910
W.	



# The Machine and Tool Smith

## The Tool Post and the Cutting Tool

JAMES STEELMAN

The tool post is the device usually employed in the United States for the purpose of holding the cutting tool to the work. There is in the typical tool post a vertical slot into which the shank of the tool may be slipped. It is held securely in place by means of a screw whose end bears against the top surface of the shank. Beneath the shank and in the slot, one may place two wedge-like strips. When these are in proper position, the top and bottom surfaces are both horizontal. By moving one on the other, we may increase or decrease the total thickness. The object in view in this arrangement is to provide for an adjustment of the tool to secure variations in height without tilting. Sometimes the surfaces of the strips which come into contact with each other are corrugated so as to prevent slipping. Another, but similar method is to use two rings, one on top of the other and both encircling the post. These washers are something like wedges—that is, they are like wedges which have been bent into rings. They are so formed, that when one is turned, the total thickness may be varied. The top and bottom faces keep horizontal, however. The shank of the tool rests on this pair of washers, coming into contact on opposite ends of a diameter. There are also other varieties employed. Some secure the change in height by slanting the shank up or down. This method is not to be encouraged, for the reason that the relation of the tool to the work is then disturbed. The shank should, save in rather exceptional cases, be held absolutely level, slanting neither up nor down. When

the height needs to be changed, the tool should still be left level. These remarks apply to the SHANK. The top surface of the nose of the tool will often be slanted. This slant will vary perhaps with the material in the work or with some other thing. But, once determined correctly, it is not desirable to vary it, as would be the case if one were to tilt the shank now up, now down.

In England, a method of gripping the tool is employed which operates by means of two (sometimes, one) clamp. That is to say, two strips of metal, each with two holes in it, are so arranged that the strips are parallel to the axis of the lathe and threaded bolts or studs project upward through the holes. These bolts or studs are secured in such way that they will not turn. The shank of the tool is put between the base and the two clamps. The shank is not put half-way between the clamps but at one end, where it is easy to slip it in and out. At the other end, a piece of metal or wood of about the same thickness is inserted. When nuts are screwed down on the four bolts or studs, the tool and also the piece of metal or wood will be held fast. Adjustment for height may be obtained by blocking the shank more or less beneath its under side. This account is to be taken as representing a typical case.

### Cutting Tools

The cutting tool will have a *shank* and a *nose*, the latter being the cutting end. Such a tool is fed in two directions. First, it is fed directly towards the axis of the rotating work. This is the *cross feed*. Second, it is fed in a direction parallel to the axis. This is the *longitudinal feed*. The form of the nose should take account of both things.

It is probable that the metal of the work is never removed by what it would be right to call a perfect cutting action. The metal seems to be partly cut and partly shoved or broken off. The tearing action appears to be especially prominent where heavy cuts are made at high speed.

Sometimes, the cutting tool will be advanced to take a heavy cut in the cross feed direction and only gradually in the longitudinal direction. Sometimes, the reverse will be the case. Sometimes, the cut will be a light one in both directions. Generally, the metal should be taken off with most rapidity at the beginning. When one gets pretty close to the finished size, the cuts

should ordinarily be light in both directions.

The top surface of the nose of a cutting tool is sometimes horizontal—sometimes it slopes upward to the work. The amount that this top surface differs from the horizontal is the *angle of rake* see Fig. 1. If brass is to be cut, it will often be proper that the top surface should be absolutely level see Fig. 3. With iron and steel, it will ordinarily be the case that we shall need to have a considerable rake in order to get the best results, see Fig. 4. I am now speaking of tools which are

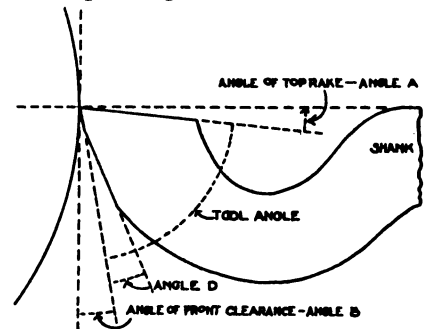

FIG. 1.—DIAGRAM SHOWING THE VARIOUS ANGLES OF A CUTTING TOOL

usually employed to cut away material from the curved surface of the work. The point where such a tool comes into actual contact with the work is on a level with the axis of the work.

The *face* of the tool is the surface which most nearly coincides with the freshly cut surface of the work when the tool is advanced in a cross feed. It lies beneath the cutting edge. Ordinarily, the face is not exactly vertical but inclines away from a vertical line dropped from the cutting edge. The round surface of the work beneath the cutting edge inclines one way from the vertical and the face inclines the other way. The angle between the face and a vertical line or surface is the *angle of clearance* of the tool.

Between the top surface of the nose and the face lies the metal of the cutting part of the tool. The angle between the line of rake and the line of clearance is the tool angle. Let it be noted now that rake angle plus tool angle plus clearance angle together make up one right angle, or 90 degrees.

A general rule as between brass and steel work is this: *The tool angle for steel work is smaller than for brass work. The top rake and the clearance for steel are both greater for brass. In general for all kinds of metal—The softer the*





metal in the work, the larger should be the tool angle and the smaller the angles of rake and clearance. This will be a very good rule to have in mind. It will be useful even where different varieties of the same material are concerned. Thus, soft steel should be cut with a dif-

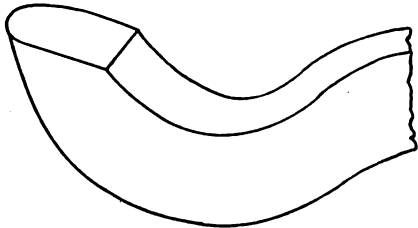

FIG. 2—THE CUTTING END OF THE TOOL IS ROUND

ferent tool nose than high carbon steel.

The clearance angle may be as small as 3 or 5 degrees and may be increased up to 10 degrees or even 15 degrees. The top rake may vary from nothing (for soft brass and gun metal) up to 25 degrees.

The tool angle will amount to what is left of 90 degrees after subtracting top rake and clearance. As the latter angles are larger for harder metal, we have the rather astonishing result that the tool angle used for hard work is less than for soft. That is, there is a tendency to less body for the cutting edge when we have hard metal in the work.

A highly recommended form of *roughing tool* is represented in Figs. 1, 2, and 4. The side view is shown in Figs. 1 and 4 and a perspective view in Fig. 2. The top rake is indicated by the angle A; the clearance by B. The face of the tool which forms one side of this angle is very small. Just below the little face, the tool slopes away rapidly from the vertical. The angle between this slope and the little face is indicated by D see Fig. 1. This is an advantage when we come to consider the work of grinding the tool every now and then. Whenever we have to grind the face, we have only a little surface to grind. If the whole front of the tool had been given the angle B, then we should have had a large face to grind. It is quite important, from the point of view of saving time, that we should look ahead and note what, in any type of tool, the grinding is going to be. Where other things are equal, we will wisely select the form which will reduce grinding. In the form of tool represented in the figure, it will be

well to raise the shank from time to time, in order to keep the edge doing the actual cutting upon a level with the axis of the work. Metal strips may be slipped in underneath the shank of the tool to provide for higher positions.

In what has been said, we have paid attention only to metal being cut off directly ahead of the tool as it is moved in perpendicularly to the axis of the work. The tool will, however, be usually cutting off metal to the left of the point of contact with the work as the tool is moved longitudinally—that is, parallel to the axis of the work. It is necessary, accordingly, to provide for rake and clearance in connection with this longitudinal movement.

This whole matter of rake and clearance is so important that it will be well to consider it from the point of view of the two feeds. The cutting tool is advanced in two directions. For both feeds, we must have rake and clearance. The rake is on the face, next the chip; the clearance is on the face next the point of the work from which the chip has just been cut. As the chip is being cut in two directions, by two feeds, we must have two rakes and two clearances. We have accordingly, *front clearance* and *front rake*. These correspond to the forward movement of the tool towards the axis of the work. Then we have *side clearance* and *side rake*. These correspond to the movement of the tool parallel to the axis.

It will be noted that the roughing tool illustrated has a rounded nose. This will result in leaving on the work a series of ridges running round and round. A *finishing tool* is employed to remove these. This tool may have the form shown in Fig. 5. The nose is not rounded but broad and flat. When this tool is properly employed and advanced slowly, the ridges will be trimmed off and the work rendered comparatively smooth.

The *parting tool* or *cutting off tool* must be given a special form to get the best results. The object in view is to cut through the work in a narrow cut. There is no longitudinal feed employed. The tool is advanced continually in towards the axis. Ordinarily, it will be a narrow blade projecting from the shank. It is desirable, not to say necessary, that its only contact with the work should be on the little edge at the end of the nose. Front rake and clearance should be provided to correspond with the

forward movement of the tool. The blade should be thickest at the extreme front and get thinner and thinner towards the shank. The object of this is to avoid contact with the sides of the groove being cut. The thinning required is a trifle. Also, the blade should be thickest at the top and thin gradually towards the bottom. This is to prevent contact with the faces of the work in the groove. This tool requires an accurate form. Otherwise, it will be liable to rub against or cut into the faces of the work as the tool is advanced further and further inward. See Fig. 6.

#### Boring

The *boring of holes* may be done on the ordinary lathe. A twist drill may be used as the tool. Either the drill is rotated and the work held in fixed position or the work is rotated and the drill held. Where the drill is rotated, it will be properly secured in a suitable chuck arranged to turn with the spindle. The work may then be secured against a drilling plate backed by the tail stock. The feed is provided for by advancing the tail stock towards the tool. Where the drill is to be fixed, it may be clamped to the slide rest and advanced with the slide rest towards the head. The work may be secured in a chuck rotated by the spindle or be clamped on to a face plate. There seems to be an opinion that a truer hole will be gotten by rotating the drill, provided the drill chuck is a good one.

There is another variety of that type of boring where the work is rotated and the drill held. The drill is not really clamped to a support, but is prevented from rotation

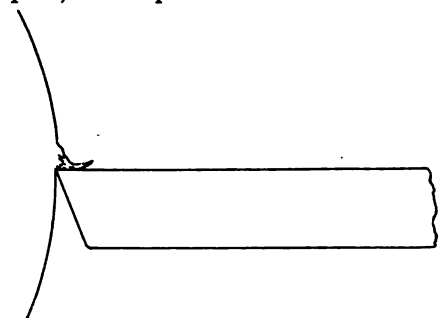

FIG. 3—FOR CUTTING BRASS THE TOP SURFACE OF THE TOOL IS LEVEL

by means of a wrench or some similar device. The drill is flat and has parallel sides, the width being the diameter of the hole desired. The shank is provided at its outer end with a center hole into which the tail stock center may be advanced. Once well started, the drill is

maintained in line by the tail stock center at one end and by the hole in the work at the other. The feed is gotten from the tail stock or the tail spindle. Again—instead of using the tail stock center, the tail spindle itself may be employed. The drill shank is inserted into the tapered hole. If the tapered hole is too large for the drill shank, a collet may be employed. When this procedure is used, the drill is prevented from rotating by means of the form of the shank and the hole into which it is inserted. Once again—the compound rest may be removed from the carriage and the work secured to the latter, the drill being rotated by the spindle of the head stock. The work may be secured directly or indirectly to the carriage, the matter being controlled more or less by circumstances. Where indirect methods are employed, an angle plate may sometimes be suitable for use. The work is

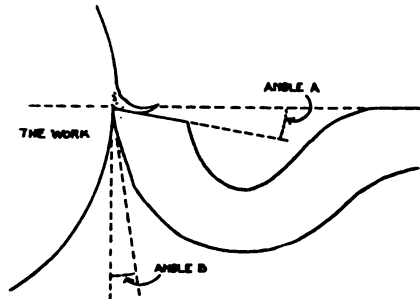

FIG. 4—A ROUGHING TOOL FOR HARD METAL

secured to it and the angle plate to the carriage.

A boring bar is often used where a hole of some kind is already in existence and what is desired is an enlargement or perfecting of it. A bar provided with suitable center holes at the ends is passed through the hole in the work and mounted on the centers of the head and tail stocks. The cutting tool is secured to the bar. The work may be strapped or bolted to the carriage, directly or indirectly. The feed is accomplished by shifting the carriage. The rotation of the bar may be secured by a dog or other carrier driven by the driving plate.

**Tool Holders**

Where high speed steels are used, it is frequently economical to use a cutting tool made of two separable parts. That is to say, a shank provided with some means of gripping is the one part and a piece of rather small cross-section, made of high speed steel, is the other part. In this way, the shank piece will be made of ordinary metal and be usa-

ble over and over again. The cutting part will be used with but little wastage. This is important, because of the cost of high grade high speed steel. It will ordinarily be best to purchase the tool holder, as the shank with the gripping arrangement is called.

This may be as good a place as any at which to set down the rules for the proper angles for tools when working on various metals. The rules are to be understood as general and subject to modification under special conditions.

For *cast steel*, the tool angle may ordinarily be given anywhere between 75 and 81 degrees. The harder the steel, the smaller the angle. It will be remembered, perhaps, that what remains of 90 degrees is to be divided between the front rake and the front clearance. Thus, if we make the tool angle 75, we have 15 left to divide between the front clearance and the front rake. It will be pretty good practice to make the front rake a little larger of the two. In this case, suppose we make the front clearance 7 degrees and the front rake 8 degrees — or 6 and 9.

For *mild steel*, make the tool angle within the range, 60 to 76 degrees. Divide the balance of the 90 degrees between front clearance and front rake, giving the latter an excess over the former.

For *cast iron*, let the tool angle be made 68 to 80 degrees in size. As in the other cases, divide the balance of the 90 degrees.

For *brass* or *gun metal*, the tool angle may be made large—from 77 to 81 degrees. The small angle remaining is divided as before. In this case, it is very proper to make the front rake very small. In fact, it may be made nothing at all.

In all the foregoing cases, let the side rake be made distinctly larger than the front rake, and the side clearance about the same as the front rake, and the side clearance about the same as the front clearance.

**Ways and Means of Painting and Finishing the Automobile**

M. C. HILLICK

The metal surface, as distinguished from the wooden one, has for the most part, its finish baked on; and by finish, we mean to say all the coats, from primer to the finishing coat of varnish. When one of this class comes in with the paint splin-

tered and flaked off to a greater or less extent, it is quite a problem to determine just what to do with it. The character of the steel, its temper, etc., have much to do with securing for the paint and varnish

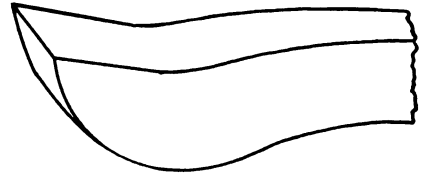

FIG. 5—THE CUTTING END OF THE FINISHING TOOL IS STRAIGHT

a secure foot-hold. Then the question of rust often arises, and this feature must be handled so that the fresh coats may stay in place. If one were located where a sand blast machine could be had, the rust might be taken off at small expense and most effectively. Without this machine, it is up to the painter to devise some means of removing the rust before painting. The places may be emieried out so that the bright metal shows clean, and for small patches the emery wheel will do very well.

As soon as the rust has been cleaned off, the metal needs to be coated at once, using a pigment that is to some extent, at least, rust inhibitive. A good metallic paint, mixed in pure linseed oil, will serve the purpose of a good primer and help to hold the rust and corrosion in check. Upon this pigment, another coat of surfacing medium should be placed. Then with a hard, drying putty, fill the cavity or depression level with the surface about it, allowing a trifle for shrinkage. In due time, rub these places down, using for the work a block of artificial pumice stone, or rubbing brick, this to be dipped in a mixture of raw linseed oil and turpentine, instead of water. Before coating up these splotches, it is always advisable to make sure that the edges of the broken surface are sound and good, paying particular attention that all the fractured edges which may be slightly loose, or inclined to scale, are taken down to the hard metal. This will then

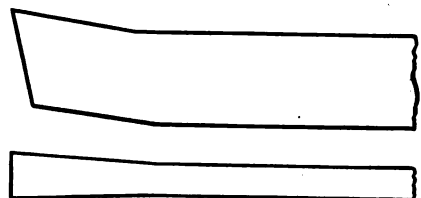
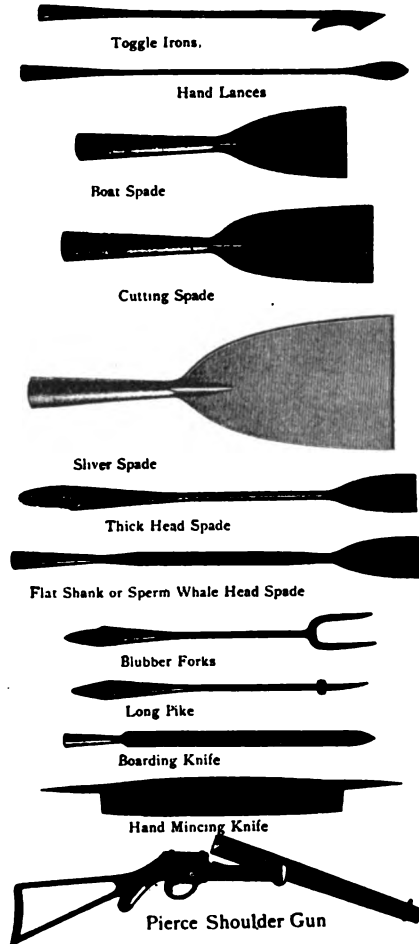

FIG. 6—SHOWING THE SHAPE OF THE CUTTING-OFF TOOL



provide a sound base for the coats to be applied. By letting some of the surface lap over the edge of the defect, the entire surface—the old and the new alike—will be as one when the rubbing has been completed. After this, the other spots on the body of the surface should have a touch up with the right color, following which a coat of varnish-color may be flowed on.

For a cheap or ordinary job this color-varnish will serve as the



#### MORE ABOUT WHALING TOOLS

ground for the finishing coat of varnish, thus bringing the work along to a finish at the expense of just two coats of material, plus the touching up and mending of the fractured spots. It is always better practice, however, when the job must be stripped and fixed up some with ornamental lines, to put on over the stripping a coat of clear rubbing varnish; rub this coat in due season with pumice-stone flour and water, to bring out the surface to a finer condition, and then apply the finishing coat. Either method will furnish a medium priced job, the latter at the additional cost of the one coat of rubbing varnish.

There is another class of jobs

which drift into the shop which fetch the ingenuity of the painter into play. They are the ones upon which the finish is cracked and fissured so badly that without burning off, the surface must be faced up and made to look quite like new. Burning off, would of course, solve the problem; and if not burning, then removal of the paint and varnish through the use of varnish remover. But not much of this sort of work is done now days, except in the cities and larger towns, and upon the finest grade of work. To take the finish off the steel or aluminum surface by burning is next to an impossibility; too expensive, at any rate, to be considered here. Varnish remover of the paste variety will do the trick, but this too is a somewhat expensive proceeding, except for the very highest class of work. So we shall not take any space at this time, at least, to describe the way of using the remover or the best method of burning off.

For these cracked and fissured surfaces give, as a first step, the work a thorough sandpapering with No. 1 paper, or No. 2, making choice to suit the surface conditions. Then follow with a coat of lead paint shaded with some color to meet the needs of the work, using in this material one part raw linseed oil to five parts of turpentine. Get a generous coat of the paint over the surface, but not more than the work will take care of. Rub the coat out well in order to have the cracks take up plenty of the filler, so that in turn they may help to clinch the facing up putty. Let this coat dry until it is hard enough to fly off in a fine powder under the sandpaper. Then go over the surface lightly with No. ½ sandpaper, after which take a mixture of 3 parts of dry white lead and one part refined whiting, mixed to a stiff paste in equal parts of rubbing varnish and coach japan, and with a broad, half elastic scraping knife draw putty the entire surface, taking care to work the pigment on very smooth and free from knife marks, these latter being almost impossible to sandpaper out. By being careful in putting this putty on and smoothing out, the work of sandpapering down can be reduced to the minimum, and for cheap work, the surface when thus sandpapered, will go very nicely by putting on the one coat of selected body color, then one coat of varnish-color, and one coat of finishing varnish, provided no lining work is desired.

If a better grade of work is required, proceed, after draw puttying the surface, to lay on a couple of coats of roughstuff, and then in due time rub down with artificial rubbing stone or brick, using for the dipping medium, a mixture of equal parts of raw linseed oil and turpentine. This will give a good, substantial foundation to work upon, and under a fair finish to protect it, will wear durably, for an old surface. Another and cheaper method consists of sandpapering the work down as already described; then coating over with a stiff mixture of roughstuff filler beaten to a working condition in a quantity of orange gum shellac. Use a fairly stiff brush and apply quickly, as the shellac filler sets up very fast. This working condition needs to be a little thinner than regular coats of filler; in this shape it will penetrate the checks better. Put on two or three coats of this filler, and then the next day rub down in the way outlined above. Bring out to a finish in the same way that it is made over the facing up putty. By exercising care and skill in sandpapering, and in rubbing when it is thought necessary to do this, a good looking job may be turned out, and the labor cost kept down to a reasonably small limit. For a first-class job over this old foundation, the surface may be coated up with several coats of regular roughstuff, over a primary filling up coat, the deepest cracks being draw puttied, as above detailed.



## Benton's Recipe Book

An excellent anti-rust mixture is made as follows: Take one ounce of rosin and melt it in one gill of linseed oil, while the mixture is hot, and stir in about two quarts of kerosene oil. Mix this thoroughly and apply with a brush or rag to such articles or tools that are likely to be subjected to damage by a rust-producing atmosphere.

A case-hardening recipe will interest the average blacksmith particularly at this time, on account of the high cost of the usual chemicals used in the average case hardening mixture. This mixture consists of one ounce each of blue vitriol, borax,

prussiate of potash, and charcoal; two pints of common salt, one gallon of linseed oil, one quart of boiling water. Pulverize the solids and boil in the water, then add the linseed oil. Heat the iron to a cherry red and plunge, stirring the mixture while the iron is cooling. By using this you can make edge tools out of iron.

A solution for hardening mill picks is another one of the frequently called for recipes. Here is another mixture which may be added to the already long list of mill pick hardening formulas: Take two ounces of alum; two ounces of saltpeter, one-half ounce of salammoniac, one and a half ounces of common salt and three gallons of soft water. Mix the ingredients thoroughly and carefully and when ready to treat the picks, heat them to a cherry red and plunge them into this solution, but do not draw the temper.

An interesting stunt, described by a blacksmith who was formerly located in a section of the dry, arid west, was as follows: He said that it is necessary to treat hammer handles in some way in order to preserve their usefulness and an excellent method he found was to bore a hole in the end of the hammer handle and to fill it with linseed oil. This hole should of course, be small although it may be several inches in depth. After pouring in the linseed oil plug it with a piece of soft wood.

To true-up oil stones, which have become uneven through long usage, rub the stone back and forth on a flat board which has been sprinkled with clean, sharp sand and water. Hold the stone lengthwise and renew the sand and water at intervals as the work proceeds.

Welding spring steel seems to puzzle F. H. K. Here's a suggestion that has been given in these columns a number of times: Take a small piece of Russian sheet iron and place on the joint just before it comes to the proper heat. This will melt and flow into the joint, making a perfect weld.

The lubricating oil used on the blower and other blacksmith shop machines is likely to become stiff during the cold days of Winter, and in consequence, is likely to retard the operation of a machine more than it is likely to assist as a good lubricant should. If this happens, use a few drops of common kerosene oil with the usual lubricating oil and this stiffness will be effectively overcome.

An iron cement for use in joining two pieces of iron is asked for by one reader. The recipe book contains the following hint on this: Take equal parts of sulphur and white lead and one-sixth part of borax and mix the three together thoroughly. When ready to use, wet this mixture with strong sulphuric acid and spread a thin coat on the surface of the metals to be joined. Then clamp and let stand for several days. When the cement mixture has dried you will find the joint sound and strong.

A paint remover is asked for by T. M. B., and while quite a number of these have been given through this column, I am glad to find a few new ones in the book and give them for this reader and others who may be interested. Take one ordinary water pail, full of freshly slacked lime, wash and add three pounds of common washing soda and a small bottle of ammonia. Apply this mixture liberally to the painted surface with a fibre brush and remove the paint with a scraper as it

softens. Several applications of this mixture may be made, if necessary, and after the paint has been removed, wash the surface carefully and thoroughly with plenty of clean water. This lime mixture is not for use on finely finished surfaces, but for large, rough painted surfaces, it works excellently and has the added advantage of being cheaply prepared. For finely surfaced furniture, wood panels and the like, a mixture of turpentine and ammonia will work very well. The mixture may be made up of equal parts of the two ingredients or the amount of ammonia may be increased as much as two parts of ammonia to one of turpentine if the equal part mixture does not work effectively. After the use of any of these paint removers, it is always well to wash the surface to be repainted, using alcohol, turpentine or water as the case may need.



Queries - Answers - Notes

Wants Spur and Bit Patterns — Can some good reader send me some patterns of bridle bits and spurs which could be made in a short course of blacksmithing?  
BRYAN HIXSON, Colorado.

Hubs, Spokes and Felloes—I am a reader of THE AMERICAN BLACKSMITH, and I would like some brother blacksmith would tell me where I can get some Bois d'arc, wagon hubs, spokes and felloes.  
J. N. POOL, Texas.

A Fire Kink—I would hate to be without THE AMERICAN BLACKSMITH if dollars do look as big as the moon. Cost of everything is going up and farmers cutting down expenses, does not help the village smith to accumulate said dollars.

What smith is there who has not had trouble with wagon tires that were pinned on? Just try driving an old mover section between tire and felloe to cut off the pin.  
C. S. CALDWELL, Illinois.

Likes the Heat Treatment Articles—I

received the bound volumes and I am very much pleased with them, also received the last month's Journal which contained an article on Carbonizing, which alone, I consider worth the full price of subscription. I am following tool dressing and carbonizing. Let us have some more on this line of work, also on heat treatment of steels.  
O. A. BLOOM, Ohio.

A Combination Plow—Old Mr. "Bull-Tung" and Miss Double Shovel, were united in the holy bonds of plow-money by W. V. Gist at his Tennessee shop, and the result is a three-plow cultivator. By putting the front foot of a double shovel on the right side of a "bull tung," you make a double plow. Put them both on and you have a three-point cultivator, or cross breaking plow for two horses.

W. V. GIST, Tennessee.

More About Whaling Tools — In the October copy I saw some whaling tools. You say some were made by a colored man, but you did not know anything about him. His name was Lewis Temple. I will show you a picture of some tools that are made here.

Frank E. Brown can give you more information about the whaling business than any other man in the United States. He had the best collection of whaling tools in the world, but he sold the whole collection to some museum. There is but one blacksmith in this city that makes a business of making whale craft and that one is in Fairhaven

H. B. B. BRALEY, Massachusetts.

Runs a Molasses Mill—I sure appreciate all you have told me and helped me in collecting bills. You could throw a brick house on some people and you wouldn't hurt them. I began to talk "law suit" to some of them and that brought in three, but these were so mad they withdrew their work from my shop but I am glad of it.

I bought a molasses mill recently and am now making molasses for this neighborhood. How does that loom up for a side line to a smithy? That don't sound like repairing autos.

F. A. SCHELEBAUM, Illinois.

Cost of Living and Smithing Prices—I notice at different times in our paper the prices of some of the smiths in different localities, and I don't see how they can stay in business at this stage of the game with flour at \$3.00 per sack; potatoes, \$2.00 per bushel; butter, 45 cents per pound; and with the advance in the material we have to buy.

We organized a little local, called the Northeast Nebraska Blacksmith's & Wheelwright's Association, July 23, 1916, and to date, have 20 members. I am President and C. W. Butts, Walthill, Secretary, and Wm. Riggs, Walthill, Treasurer.

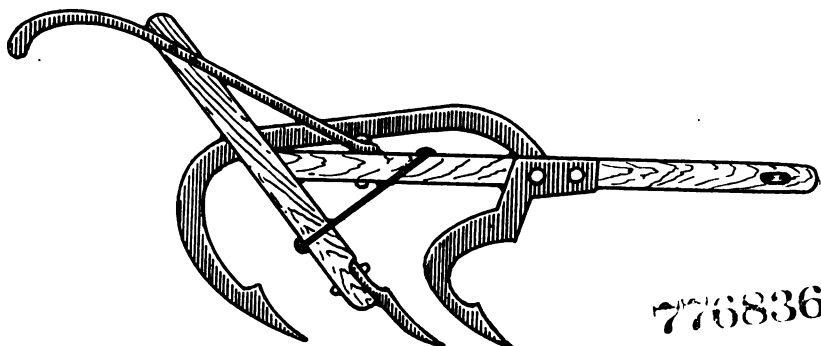

776836

A COMBINATION PLOW SUGGESTED BY MR. W. V. GIST



I think every smith ought to join and go to every annual meeting. I was gone 3 1/2 days this year and came home a much wiser smith, feeling as though both time and money were well spent.

C. P. HARDY, Nebraska.

Earnings and Prices—in the October issue of Our Journal, Brother Jacobs of Kansas, expressed a desire to hear from other smiths in regard to what their net earnings should be. That depends very much on how much purchasing power a dollar has. This is not very much at present. In some places, it has more than others, but will say that \$2.15 is not enough for a mechanic that is busy most of the time. Most anyone can get that and more for unskilled labor. I can not understand why Brother Jacobs has not made more than \$2.15 per day with the prices that he quotes. I am glad to say that my net earnings were more than \$2.15

In Reply—In order to simplify the calculation of stock for this hanger, we will divide it into three parts; the half circle being one part, the straight reins being the second part, and the two eyes at the end being the third part. The rule for the calculation of stock for circles is as follows: To the inside diameter of the circle, add the thickness of the stock; this sum times three and one-tenth; and for a half circle, such as is required in the pipe hanger, it will be necessary to divide by two. The calculation for the reins of the hanger is of course simple, being simply the measurement on each side from the half circle to the beginning of the bend for the eyes on the ends of the reins. The stock for the eyes is calculated the same as the calculation for a complete circle, except that nothing need be allowed for welding, inasmuch as the eye is merely a turned eye and not a welded eye.

done very easily by preparing the ends to be welded as per the engraving at A. The projections, measuring three inches in width at each side of the stock, are scarfed in the regular way as shown and then welded—one side at a time. When welded the piece will have a slot measuring nine inches in length. The edges of this slot are now sloped V-shape with the fuller, as shown at B and at C, in the sectional view. Now, a V-shaped piece is forged to fit into the slot with material enough for welding. The wide piece is now heated up and the slot filled up at one end first. Weld only as much as you can easily with one heat. Don't force your weld and take another heat when necessary until the entire length of the V-shaped piece is in place. In heating that portion of the stock around the slot, you will find that placing a fire brick over the stock while heating it, will assist in getting a thorough heat in your stock. This method, if followed carefully and by an experienced welder, will result in the successful welding of stock of any reasonable width. O. L. T., New York.

A Missouri Price List—The following list of prices went into effect on November first. Some old prices are given so that the amount of advance can be readily seen:

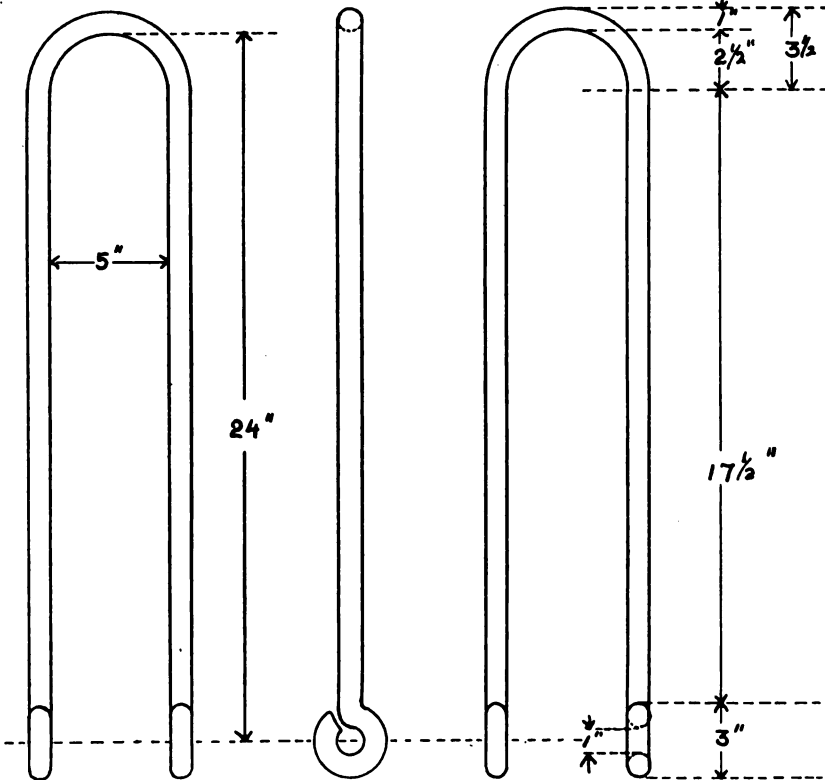

CALCULATING STOCK FOR PIPE HANGERS TO BE MADE IN QUANTITY

per day, and I was not so busy but that I could have done more at times. And my prices were not as high as his, but they were not what they should be, owing to the advance in cost of material. Brother Jacobs is either a little slow or he needs to cut out some of the leaks. Perhaps the latter, which is a very important part of the business. We should keep an account of our income and also of our expenses and let us keep our old records and if they are not up to what they were, let us learn why they are not and see if we can not make them better. Brohter Jacobs can diagnose his case better than any one else, but there is something wrong. Now let us hear from some of the other boys.

G. N. SIDDEBS, Ohio.

Calculating Stock—I have a lot of pipe hangers to make and would like to know how to figure the stock for them. The size and dimensions are given in the accompanying engraving (at A). The eyes are not welded and the hangers are to be of one-inch round iron.

J. W., Massachusetts.

Let us take, for example, the making of these hangers from one-inch stock. The inside dimension of your hanger is five inches, this must therefore be the inside of the circle, therefore our calculation for the stock required in the half circle at the end is five plus one times three and one-seventh divided by two, which gives us about nine and one-half inches. The rein length measures seventeen and a half inches and twice this length would be thirty-five inches. The stock required in each eye, we figure at six and a quarter inches, or for both eyes, twelve and a half inches. This gives us a total of fifty-seven inches of stock required for each hanger. S. S., New York.

Welding Wide Stock—I have some bands to make from stock, fifteen inches wide. How can I weld this stock in the ordinary fire? Can you help me out?

L. J. THOMAS, Ohio.

In Reply—Difficulty would, of course, be experienced in attempting to weld this width of stock in the ordinary fire in the regular way. However, this work can be

WAGON WORK

	New Prices	Old Prices
Wagon Circle, Hounds...	\$ 4.00	\$3.50
Wagon Spokes, each.....	.25	
Wagon Spokes, all in wheel	.20	
Wagon Felloes .....	.25	
Buggy Tongues .....	3.50	3.00
Buggy Tongues Circle ....	1.00	
Buggy Shafts, each .....	1.75	1.50
Buggy Shaft Cross Bar...	1.00	.75
Wagon Tongues .....	3.50	3.00
Wagon Axles, 4 1/2 and under .....	3.50	3.00
Wagon Bolsters, new, complete .....	4.00	3.50
Wagon Bolsters, old irons	2.50	2.00
Sandboards .....	2.00	
Wagon Tongue Hounds, ea.	1.00	.75
Wagon Hind Hounds, ea.	1.25	1.00
Wagon Reaches, 12-foot...	1.25	
Buggy Reaches, Straight, each .....	1.00	.75
Buggy Reaches, dble bend, each .....	1.50	1.00
Cutting Down Wagon ....	10.00	9.50
Setting 4 Wagon Tires....	2.50	2.00
Setting 4 Wagon Tires, drill and Bolt .....	3.50	3.00
Setting 1 Buggy Tire....	.65	.50
4 New Buggy Axle Stubs, 1 inch and under.....	8.00	6.00
4 New Buggy Tires .....	8.00	6.00
1 New Buggy Tire .....	2.00	1.50

BLACKSMITHING

4 New Shoes, No. 3 and under .....	\$1.50	\$1.50
1 New Shoe, No. 3 and under ..	.40	
4 New Shoes, No. 4 and 5 (2 new shoes, 90c) .....	1.75	1.50
1 New Shoe, No. 4 and 5 (2 new shoes, 90c).....	.45	
4 New Shoes, Nos. 6 and 7	2.00	1.50
1 New Shoe, Nos. 6 and 7	.50	
4 New Shoes, hand turned	2.50	
4 Old Shoes, Plain .....	1.00	
4 Old Shoes, Toed .....	1.20	
Shoeing Stallions, if gentle	2.50	2.00
Sharpening Plows, 12-inch	.25	.25
Sharpening Plows, 14-inch	.30	.25
Sharpening Plows, 16-inch	.35	.25



Sharpening Plows, 18-inch	.40	.25
Sharpening and Pointing Plows	1.00 & up	1.00
Sharpening Listers	.50	.40
Sharpening Subsoilers and Jointers	.15 to 25	
Pointing Listers	1.25	1.00
Pointing Cultivator Shovels, 4 large	2.25	2.00
Pointing Cultivator Shovels, 6 small	2.75	2.50
Polishing Plows, complete, 12-inch	1.25	1.25
Polishing Plows, complete, 14-inch	1.50	1.25
Polishing Plows, complete, 16-inch	2.00	1.50
Sharpening Road Grader Blades	3.00	2.50
Sharpening Discs, up to 16-inch	.20	
Sharpening Discs, up to 18-inch	.25	
Sharpening Discs, up to 20-inch	.30	
Plow Shares, 12 and 14-in.	3.50	3.00
Plow Shares, 16-inch	4.00	3.50
Plow Shares, 18-inch	4.50	4.00
Welding Sickels	.75	.50

ROY C. BROWN, Missouri.

receiving tank, and then over the edge of the receiving tank and down into the tank which is to receive the clear oil. Before hanging these wicks on the tank, dip their entire length into good clear oil, and then hang them on the tank as shown. If four wicks do not filter the oil quickly enough, others may be added to facilitate filtering.

With a simple filter of this kind, the practical auto repairman will be able to reclaim considerable good lubricating oil, which he would otherwise throw out as unsuited for future use.

### Repairing Clutch and Gear-set Troubles

VICTOR W. PAGE, M. S. A. E.

The clutch is one of the most important elements of the power transmission system in any self-propelling road vehicle. If the clutch is at fault the efficiency of the entire transmission system will be affected and considerable power will be lost (especially in the case of a slipping clutch) that will otherwise be available in turning the traction wheels. While clutches are made in numerous forms they may be grouped in two main classifications, the cone and the plate forms. The same defective conditions may materialize in any form of clutch, though of course, the method of repair will depend upon the individual structure. Fortunately, any clutch defect may be easily recognized. One of the most aggravating faults is too sudden engagement, which causes "grabbing" and which results in a sudden start that is not only a serious detriment to the comfort of the passengers but which also imposes severe stresses in the various parts of the transmission system. Failure to engage properly means that considerable slipping will take place and power loss will be evidenced by heating of the clutch member. Some clutches may engage properly and yet there may not be sufficient frictional adhesion between the clutch parts to insure positive driving under heavy loads. The failure of a clutch to release promptly also causes trouble, which is evident by difficulty in gear shifting. When the clutch pedal is depressed the parts remain in partial contact and will cause the gears in the transmission to turn and make it extremely difficult to engage any desired speed ratio without clashing and grinding of the gears.

The cone clutch shown at Fig. 1

is the simplest type and is the form that usually employs a leather facing to increase the friction between the male and female clutch members. All clutches using leather are bound to cause trouble after a time, because of natural wear or some defect of the friction facing. If the clutch has been slipping continually, the heat produced by the

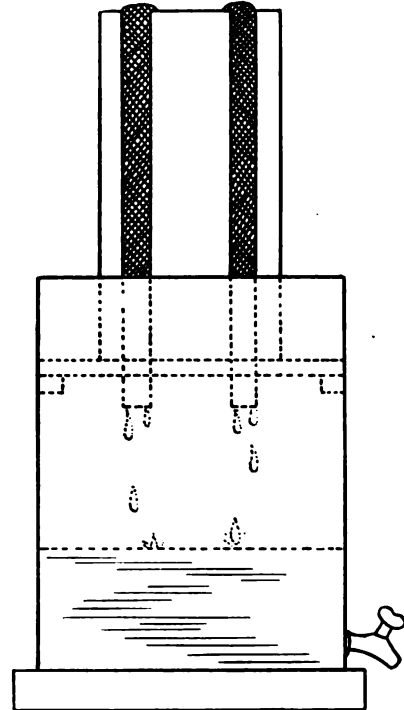

A SIMPLE OIL FILTER FOR THE AUTO SHOP

waste of power may be sufficient to burn or char the leather facing. Even under normal conditions of use the leather may have become hardened by packing down the continuous hammer action produced by repeated clutch actuation. A leather facing on a clutch having a heavy spring is more apt to pack down than on the types where the spring pressure is more moderate. When the leather is hard and lacks resiliency, the clutch not only engages harshly but owing to the reduction in the friction co-efficient, (which is less with hard surfaces than with soft ones) it is apt to slip when transmitting nearly the full engine power. The clutch spring may have weakened and in rare instances it may have broken in service. Either of these conditions will result in any form of clutch slipping, even if the friction material is in good condition. The most common troubles met with by the motorist and those that the repairman is called upon to correct most often is harsh action as one extreme condition and loss of power from slipping as the other.



## The Automobile Repairman

### A Simple Oil Filter for the Auto Shop

F. J. BERGER

A simple oil filter, by means of which dirty oil from the crank case, and the accumulations from other sources, may be made useable, is easily made by any practical shopman. The illustrations show an oil tank of generous proportion with a faucet, or small petcock as shown. The receiving tank for the filter is one that will fit easily into the first tank, as shown in the engraving. This tank may set into the first, or larger tank as shown, or it may be set upon a couple of rods which are laid across the top of the larger tank.

To put the filter in operation, pour the dirty oil into the receiving tank, and then take four pieces of lamp wicking of sufficient length, to dip well down into the oil in the



When the cone clutch, such as shown at Fig. 1 engages too suddenly, it generally results from the surface of the friction facing becoming hard and as the resiliency is reduced, it cannot yield as a soft

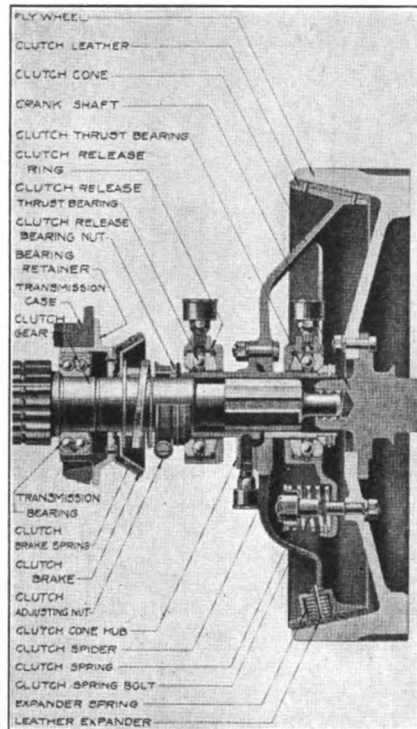

FIG. 1.—SECTIONAL VIEW OF BUICK CONE CLUTCH

frictional contact with the driving member. The facing should be soft and springy to insure gradual clutch application. If the leather facing is not too much worn or charred by burning, it may often be softened by rubbing in some neatsfoot or castor oil, or any good harness dressing of an oily nature. Kerosene oil is often enough to keep the clutch leather pliable and it has the great advantage of possessing so little lubricating value that the clutch is not apt to slip after it is applied. The dressings and oils having more body do not soak into the leather as quickly as light bodied kerosene does and they may lower the co-efficient of friction enough to cause slipping because they act as a lubricant. Kerosene also has the advantage of quick penetration and it is not apt to collect grit or gum up as the more viscous oils are.

To apply oil to a clutch, the best method is to lift the floor boards to gain access to the affected parts and then to hold the clutch out by putting a stick of wood of the proper length between the clutch pedal and the heel board under the seat.

If this cannot be done conveniently, it may be possible to hold the clutch pedal in the released position by wedging a block of wood between the actuating lever and some portion of the frame or by wiring it to some part of the mechanism. The clutch cone, now being released, can be turned by hand if the gearshift lever is put in neutral position and the dressing applied to the leather surface by means of a piece of tin or a discarded hacksaw blade. The important point to observe is to distribute the oil evenly over the clutch surface and to work it in thoroughly after the entire surface has been covered, by running the engine slowly and continuously engaging and releasing the clutch for a time. It is well to let the oil soak into the leather before the car is driven.

While the proper quantities of oil on a clutch leather are very necessary, too much oil results in slipping, especially if it is lubricating oil that has leaked into the clutch from a thrust bearing or spigot bearing. The remedy for defective clutch action produced by a surplus of oil is a simple one. The oil should be absorbed by rubbing a small quantity of Fuller's earth or borax into the leather surface. It is apparent that if the clutch cone is in place, the surface of the leather cannot be easily reached. The cone may be held out of engagement by any of the means previously described and enough of the powder placed on a piece of tin or card so it can be sprinkled into the space left between the cone and the flywheel when the former is properly released. Rosin has been recommended for this purpose but unless powdered very fine it should never be used. Rosin is apt to become a lubricant if it melts from the heat due to clutch slipping and only aggravates the slippage. If Fuller's earth is not available, the fine lime residue from a carbide gasgenerator may be used to advantage in absorbing the oil. The writer has known of instances where a handful of road dust or sand has been used as an emergency absorbant, but this is not good practice, because there may be grit enough included to injure the flywheel friction surface by grooving it, and perhaps cause damage to the thrust bearing by getting into it.

If the slipping is due to a worn clutch leather the only remedy is to remove the clutch cone and replace the leather facing with a new one.

If the clutch is part of a popular make of car, it will be much cheaper to procure a facing already cut from the manufacturer. Of course, if a new clutch leather must be made, it can be cut very nicely from a piece of oak tanned leather belting which has not absorbed too much oil. The defective clutch facing may be used as a pattern, or a new pattern may be made by first cutting a strip of paper so it will conform properly to the cone circumference and using that as a guide as indicated at the top of Fig 4. It will be noticed that the leather for replacement will be in the form of an arc and not a straight strip. This form is made necessary because the two edges of the clutch cone are of different diameters. If slippage is caused by a weak clutch spring and means of adjustment are provided, the spring tension may be increased and preater driving power secured. On the Buick clutch shown at Fig. 1 and the Overland clutch, for instance, three springs are used. The tension of these may be increased very easily

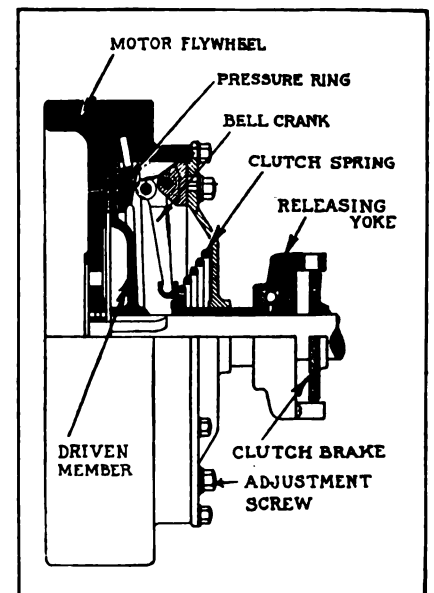

FIG. 2.—PART SECTIONAL VIEW OF BORG AND BECK THREE PLATE CLUTCH

by tightening the tension nuts. If no adjustment means are provided the spring tension may be increased by interposing spacing washers of sufficient thickness between the ends of the spring and its abutments.

A very annoying condition that is sometimes noticed when a cone clutch is used is continued rotation or "spinning" of the cone when the clutch spring pressure is released. This may be the result of natural momentum but it is



sometimes produced by a defect in the clutch mechanism. If the bearing on which the cone revolves when disengaged is a plain bushing, it is apt to seize because of lack of lubricant. Under such conditions there may be sufficient friction between the bearing parts to drive the clutch cone around even when the full spring pressure is released. The tendency of most cars is to use small ball bearings for this purpose and of course the liability to stick,

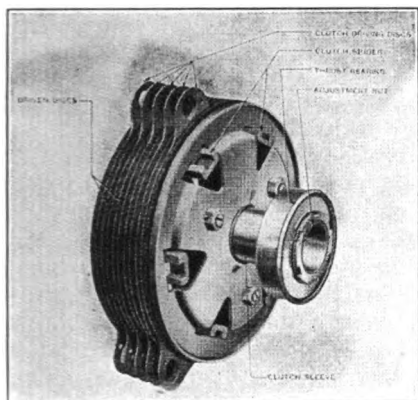

FIG. 3—DISC ASSEMBLY OF CHALMERS MULTIPLE PLATE CLUTCH

is greatly reduced. In practically all clutches a ball thrust bearing is used to resist clutch spring tension when the clutch is released. If this bearing becomes stuck or wedged because of a broken ball, faulty separator or flaked raceway, the rotation of the crankshaft will be imparted to the cone member. The spring in this case acts as a clutch, and as it must turn with the crankshaft instead of remaining stationary as would be the case of the thrust bearing was functioning properly, it forms a driving connection between the parts.

On those cars where multiple disc clutches are used, the same trouble may be experienced. If an all-metal multiple disc clutch as outlined at Fig. 5 D does not disengage promptly, it may be because the surfaces of the plates have become rough and tend to drag. The friction plates must always have a smooth surface because the clearance between them is relatively small even if the clutch spring pressure is fully released. In those types where the plates are supposed to operate in an oil bath, harsh engagement may result from absence of lubricant. Spinning or continued rotation of a multiple disc clutch generally is caused by seizing due to gummed oil, the presence of carbon or burnt oil between the

plates and sometimes because of an actual lack of proper lubricant between the members. When a multiple disc clutch slips, the fault is generally weak clutch springs or distortion of the plates. If the clutch has been used when it is slipping, considerable heat will be produced and the plates may warp and the surfaces be badly cut up or grooved. Under such conditions the clutch must be taken apart and all the lates smoothed off with a surface grinder, after they have been properly straightened. In some cases, slipping has been due to "brooming" which is a condition that exists when the sides of the keyways or the driving edges of the disc become so burred over that full contact of the plates is not possible.

To secure the best results from an all metal multiple disc clutch, it is necessary that proper oil be used. If one uses inferior oil it will gum up or carbonize easily if there is much heat evolved when the plates slip by or it may have such a heavy body that it will gum up and stick the plates together. While this type of clutch is not as widely used at the present time as it was in the past, there are still a number of cars in service employing clutches of this type. It is therefore important that only the proper oil be used. The usual mixture is about half light cylinder oil and half kerosene. In dry plate clutches such as shown at Fig. 3 fewer discs are used and the driven set, or that which drives the gearing is usually faced with asbestos friction material, practically the same as brake lining. These clutches give very little trouble and when the friction material wears it can be readily replaced. Oil should never be put in clutches of this kind unless recommended by the maker.

Faulty clutch action has often been traced to points outside of the clutch itself. Some cases of failure to release promptly have been found due to imperfect relation or adjustment of actuating levers or rods, or depreciation in some mechanical part. If a clutch shifting collar is worn too much, or if the small pins in the rod ends connecting the clutch pedal with the release mechanism have worn to any extent, the pedal may be fully depressed and yet the movement of the clutch cone or driving member may be so slight that the spring pressure is not reduced appreciably. Naturally as long as the driv-

ing contact is maintained even to a slight degree, the clutch member that should be free to permit easy gear shifting is still rotating and results in noisy gearshifts. On some of the early types of cars the emergency brake lever may have an interlocking leverage so that the clutch is automatically released when the brake lever is applied. Cases have been known where the brake rods were shortened to adjust the brakes and this change has resulted in throwing out the clutch mechanism slightly and thus causing the clutch to slip. This condition may be produced on any Ford model T cars, if the interlocking screw between the emergency brake lever and the clutch throw-out is not adjusted properly.

The Ford Model T is the only car now manufactured which uses a planetary transmission, but so many of these cars are in use that every repairman should be familiar with their construction. This is shown at Fig. 5A. The chief trouble with a planetary transmission is caused by slipping clutch bands. These are provided with adjustments that can be tightened in case the linings wear and must grip positively and yet release absolutely when the pressure is taken off the foot pedals. If either the slow speed or reverse bands or the

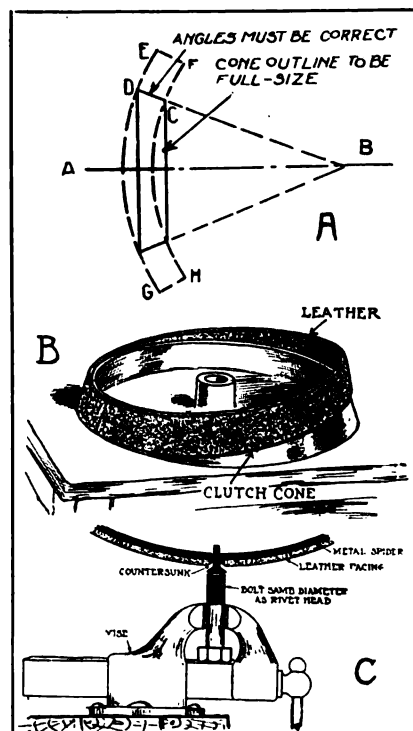

FIG. 4—OUTLINING STEPS IN REFACING CLUTCH CONE. A—HOW TO LAY OUT PATTERN FOR LEATHER—B—STRETCHING LEATHER ONTO CONE—C.—RIVETTING LEATHER TO CONE



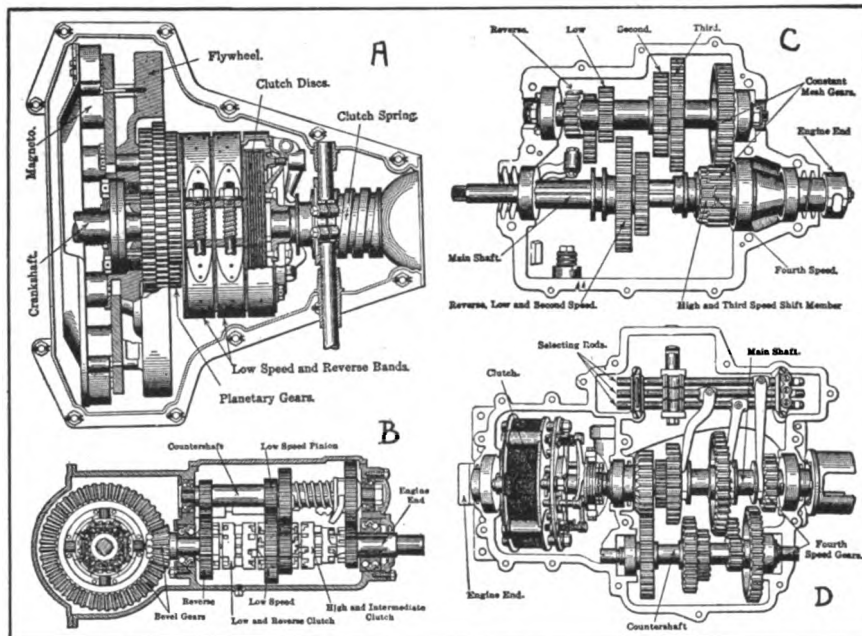

FIG. 5—TYPICAL CHANGE SPEED GEAR DESIGNS. A. PLANETARY GEARSET OF FORD—B. INDIVIDUAL CLUTCH TYPE WITH GEARS ALWAYS IN MESH.—C. WHITE FOUR SPEED SLIDING GEAR SET.—D. WINTON MULTIPLE DISC CLUTCH AND FOUR SPEED SLIDING GEARSET

foot brake bands are adjusted too tightly, they will bind on the drums and produce friction, so the efficiency of the car will be lowered when in the direct drive. Noisy action of this planetary gearing is usually caused by lack of lubrication which produces depreciation in the planetary gear bushings and in the drum bearings and allows these parts to rattle around. Sometimes a high speed clutch may slip but this is easily adjusted by turning in set screws that are found in the clutch actuating fingers.

Most automobiles built today are provided with sliding gear transmissions as outlined at Fig. 5 C and D, and these are so well made that only very careless operations and abusive treatment will cause untimely depreciation. The common defects are difficulty in gear shifting and noisy operation. The difficulty in gear shifting is generally caused by a spinning clutch but if the trouble is in the transmission, it is usually found that the edges of the teeth on the shifting gears have burred over so they do not pass readily into spaces between the teeth of the gears they engage with. The only remedy for this condition is to take out the gears and grind off the burred portions of the teeth so as to restore their original shape. Another common cause of poor gear shifting is depreciation in the shaft bearings, as any lost motion at these points may alter the center distances of the shafts to a certain degree

and the relation of the gears may be so changed that their pitch circles will not coincide and as a result they will not slide into mesh as freely as they should.

Noisy operation is usually due to poor lubrication and if the gears and bearings are not worn too much, it may be reduced to a large extent by filling the gear case with semifluid oil, having sufficient body to cushion the gear teeth and yet not such a heavy body that it will not flow readily to all bearing points. Sometime noisy operation is caused by using a solid grease that is so thick that the gears merely cut channels through it and owing to its heavy body this grease does not flow back to fill the grooves churned out by the gears. Under such conditions the gears are soon deprived of lubrication and the metal to metal contact cannot fail to produce noise.

A difficulty in gear shifting is

sometimes caused by binding in the control levers or selective rods. If considerable difficulty is experienced in meshing gears and the trouble is not found in the gearset, the defective condition may be present in the clutch. Badly worn plain or anti-friction bearings must be replaced with new ones and if any of the gears have broken teeth or have so much of the teeth ground away as to seriously reduce the effective tooth length, it will be necessary to supply new gears. In rare instances a shifting fork has broken inside of the transmission or the pins by which it is fastened to the selective rod have sheared off, this allowing the rod to move without producing a corresponding movement of the sliding gear. A condition of this kind must be remedied promptly as the transmission is apt to be seriously damaged because of two sets of gears may engage at the same time. Clutch and gearset troubles have one important advantage over engine troubles and that is that they are easily recognized as they result for the most part from actual mechanical failures which are promptly located and susceptible to ready repair.

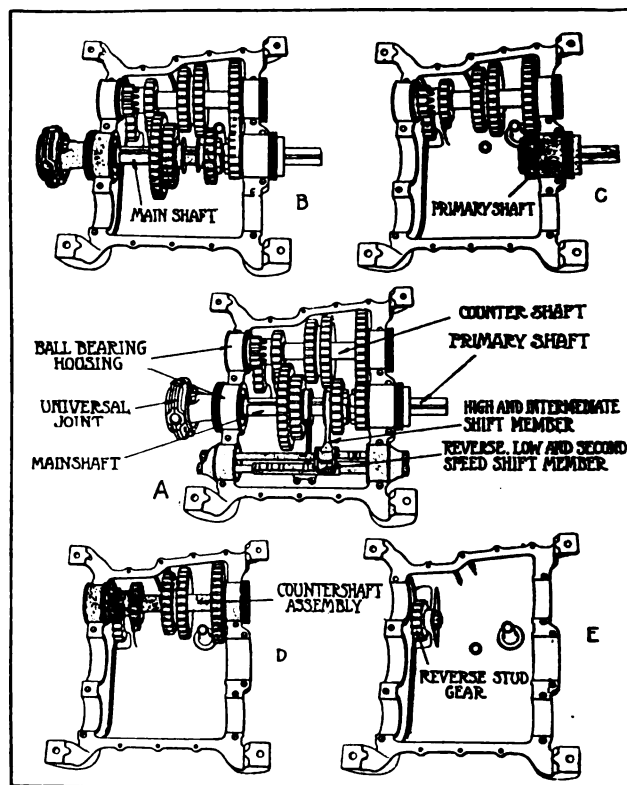
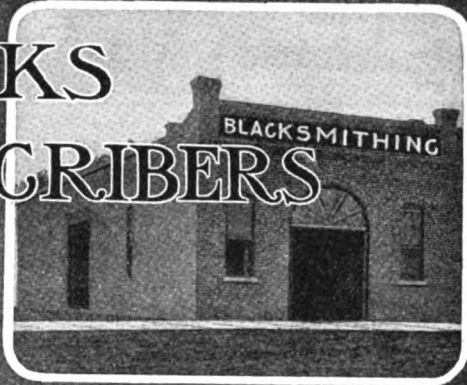

FIG. 6—OUTLINING STEPS IN TAKING DOWN FOUR SPEED GEAR BOX. A—MECHANISM WITH TOP HALF REMOVED. B—SHIFTING ROD ASSEMBLY REMOVED. C—MAIN SHAFT OUT. D—PRIMARY SHAFT OUT. E—AFTER COUNTER SHAFT ASSEMBLY IS TAKEN OUT.



# TIMELY TALKS WITH OUR SUBSCRIBERS



The American Blacksmith is published monthly at The New Sidway Building, Buffalo, N. Y., U. S. A., by The American Blacksmith Company. Incorporated under New York State Laws. Entered, February 12, 1902, as second-class mail matter at Buffalo, N. Y., Act of Congress, March 3, 1879.

William F. Wendt, President  
Associates: James Cran - Albert W. Bayard, Secretary - Walter O. Bernhardt, Editor  
- Bert Hilmyer - A. C. Gough - Dr. Jack Seiter  
Subscription Price: \$1.00 per year in advance, prepaid to any postoffice in United States or Mexico. To Canada, \$1.25; other countries, 6 shillings. Reduced rates to clubs of five or more on application. See "Honor Roll" page for money-saving, long-time rates. Cable address, "Blacksmith," Buffalo. Lieber's Code used.  
Subscribers should notify us promptly of non-receipt of paper or change of address. In the latter case it is necessary that you give us both the old and the new address.

### The American Blacksmith and Better Mechanics

You readers who have been reading THE AMERICAN BLACKSMITH and watching its good work, will be interested in looking over a letter just recently received from a New Jersey member of our big family. Mr. C. M. Oakes of Newton, N. J., writes: "We would have lot better mechanics if they would all take THE AMERICAN BLACKSMITH and be governed by its teachings. It certainly contains a lot of good information."

This letter, while the expression of but one reader, aptly expresses the ideas, held by readers of "Our Journal" in practically every corner of the English-speaking world. Letters of this kind are not exceptional; they are the ideas of readers everywhere, from far away Australia and New Zealand and come letters of recommendation and encouragement, from England, Scotland and Ireland, come expressions of appreciation, from far off South Africa, come words of satisfaction and from every point of Our Own Land come floods of letters that carry words of gratification and satisfaction.

Why not tell your neighbor smiths what THE AMERICAN BLACKSMITH is doing for you and the craft?

#### The Pink Buffalo Stamps

We have sent a good many thousand Pink Buffaloes scurrying across the country during the past few months. Did you get some? If not you should have some—you are entitled to them. Better get busy right now, simply drop us a card asking for some "Pink Buffalo Stamps" and they will come to you by return mail. These stamps are free to you, and are one of the links in our chain of protection with which we surround each of our readers.

#### Subscription Agents

When a stranger solicits your subscription to THE AMERICAN BLACKSMITH or any other publication, insist upon him showing you absolute proof that he is an agent in good standing and is employed by the publication which he represents. Don't under any circumstances, give the man your money if you are not sure that he really works for the paper he says he does. No matter what the man offers you—no matter what price he makes—no matter what premium he promises to send—Don't Give Him Your Money If You Are Not Sure.

### Contents, February—1917

The Longer the Bar the Harder the Squeeze .....	106
Cutting Out the Guess Work .....	107
A Cash and Credit Price .....	108
The Fable of the Shop Owner Who Was There With the Punch but Not With the Figures .....	109
Shoeing Prices Vs. General Smith Prices .....	109
Who Must Stand the Loss of this Fire .....	110
A Great Horseshoeing Plant .....	110
The Three Types of Horses' Feet and How They are Shod .....	111
Shoeing for Quarter Crack.....	113
Gas Engine Operation Made Simple..	113
Oxy-Acetylene Welding Hints .....	115
Why a Wheel is Dished .....	116
Thoughts on Timely Topics .....	116
The Smith in the Daily News .....	117
Old Man Rut—Verse .....	118
Heats, Sparks, Welds .....	118
Our Honor Roll .....	119
The Machine and Tool Smith .....	120
The Cutting Properties of High Speed Steel on Cast Iron.....	120
Notes on the Theory and Practice of Hardening .....	124
John L. Sullivan and the Village Blacksmith .....	126
A Handy Chart for Finding the Volume of Tanks .....	127
Gas Engine Bearings .....	128
Benton's Recipe Book .....	128
When Working Steel .....	128
When Drilling or Filing .....	128
A Blackboard Paint .....	128
A Cement .....	128
An Excellent Mixture for Woodworking .....	128
The Tempering Composition .....	128
To Remove Rust .....	128
A Suggestion .....	128
Queries, Answers, Notes .....	128
Has a Forging Horse .....	128
Wants to Know About Drop Forgings .....	128
Taking up Auto Work .....	128
Blacksmith Devises an Entirely New Tool .....	128
A Defense of the Craft .....	129
Welding Wide Stock .....	129
The Automobile Repairman .....	129
A Trio of Automobile Hints .....	129
A Practical Method of Turning Rough Brake Drums .....	130
Assembling Light Car Rear Axle....	130

### Books on the Automobile

Our book department can now supply you with most any kind of books on automobile work. These books are reliable and have only been selected after carefully investigating the merit of each one. We have books on most all branches of automobile construction, operation and repair. Every book is sold on the same guarantee of money back if not satisfactory. If you are in need of information on any branch of automobile work, write our book department today. Tell them what you need, and if we haven't got just the book you want we can get it for you, if it is in print.

We might mention in this connection, that the same applies to books on practically any other subjects connected with the smithing and horseshoeing trade. If you have any questions to ask regarding any books, address the Book Department—you will find them willing and anxious to assist you in getting just exactly the book you want.

### Readers as Reporters

There is perhaps no other publication, which is more surely the readers' own paper than THE AMERICAN BLACKSMITH. "Our Journal" is the readers' paper, not merely in name but in fact. THE AMERICAN BLACKSMITH, since the printing of the first issue, had been devoted to the interest of the blacksmithing craft, first, last and always, and we want every reader of the paper to consider himself a contributor or reporter. We want you to tell us what you are doing, what your neighbors are doing. If a new smith moves into your neighborhood or into your town, let us know about it; if you have purchased a new machine or put in power, or have made other changes in your business, tell us about it, and how you like it. In short, let us have every little item concerning anything pertaining to the smithing craft. Nothing concerning the smithing trade, is too small to warrant our attention, and do not think for one minute, that you can write us too much or too often. We want to keep in close touch with you and the trade and can only do so with your help. Keep this in mind Mr. Reader, and write right now, if there is something of interest that you think we should know.

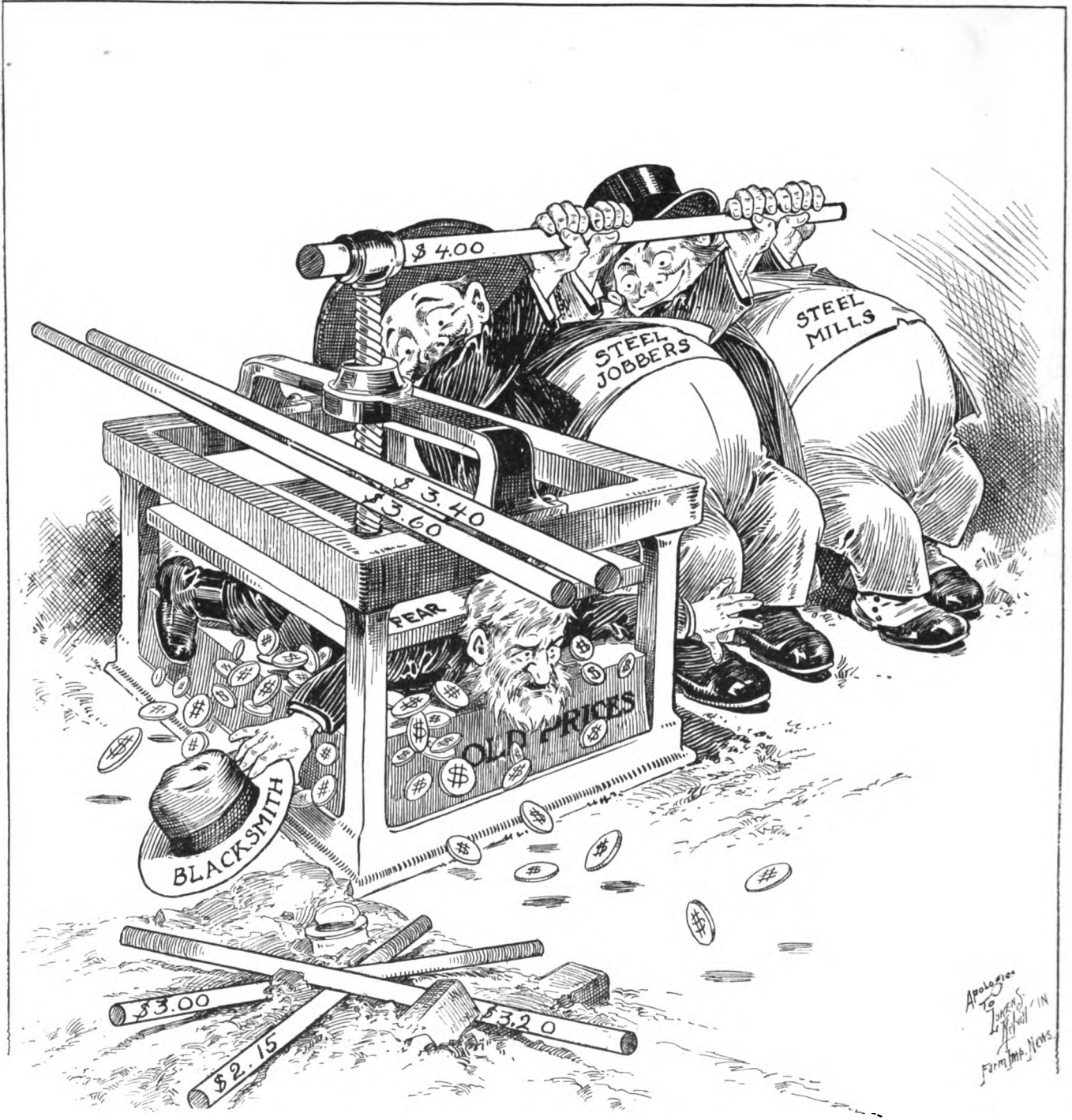

**THE LONGER THE BAR THE HARDER THE SQUEEZE**

These are strenuous days for the Smith. Caught between Old Prices and Fear to make new rates, he is slowly but surely losing money. The Steel Mills and Steel Jobbers are increasing the leverage on that bar and no one seems to know when the limit will be reached. Fear is holding the poor smith down to old prices. Why not get busy and do some price adjusting? Tear up the old price list. Get busy on the new basis of adjusting your prices according to costs. New costs aren't costs of last year or five years ago. Don't let fear hold you down to old rates any longer. Your customers are expecting to pay more for their blacksmith work. They know that iron, steel and all materials have advanced. Then why hesitate? Pass the squeeze along—don't try to absorb it all yourself.



# Cutting Out The Guess Work

## The Present Need for Accurate Cost Records and How to Get Them

J. F. MILLER

**T**HE need for accurate cost records was never more apparent in the general blacksmithing trade than it is today. With advanced costs and buying prices still advancing with no limit yet in sight, the practical business smith must realize that he must be more vigilant than ever, in order to show a balance on the profit side of his ledger.

The smith who has failed to raise his prices within the last four or five years, has long since had his profit absorbed in the increased costs of not only supplies and materials, but labor as well. And when one considers the continuing rise in the cost of living, it becomes somewhat of a puzzle to figure just how some

there be a possibility of their showing a balance on the right side of their books.

As actual figures and records show, the cost of supplies have advanced all the way from 40 to 100%, it is impossible to continue to make a profit on general work without a re-adjustment of prices. Guess work will no longer do, for a guess at profit usually means a miss. The agreed price-list, while a step in the right direction is not the proper solution to the problem. Accurate cost keeping records in the individual shop will solve the problem and give to the shop owner the profits to which he is rightly entitled.

Now then, how are we to keep cost records? In the first place, any business worthy of the name is worth the time necessary to keep accurate records. The reason you or any other smith is in business is to make money, not for the sake of the money itself, but for what the money will bring you. You cannot keep track of your business unless you keep records. Business means money. Therefore, you cannot keep accurate record of your money unless you keep some books, cards or follow some other accounting system. So you see this matter of keeping business records, hits you in the most vital spot connected with business, namely, the pocketbook.

### Finding the Cost of Doing Business

In accurate cost accounting, the most important item to consider is the cost of doing business, i. e. the sum or percentage which each job, every piece of work and every item must carry. This item is also known as "over-head", and it often proves to be the little stumbling block which is responsible for so many failures in the hunt for profits. It is the item of over-head that makes impossible an agreed price-lists that will be accurate for every shop, because of the fact that the over-head item or cost of doing business is not the same in every establishment.

In order to determine correctly what our cost of doing business

really is, we must consider every expense item that enters into the business. First, we must determine what our real investment in stock, machines and fixtures amounts to. This can only be shown by a careful inventory of our stock and equipment. Every item that enters into the business must be included, i. e. all stock, equipment, machinery, tools, furniture, books, lighting and heating equipment and every item that goes to make up the business investment.

With the amount of the investment correctly figured, we now proceed to figure the total of all expenses in the business. The first item to consider is the Interest on the Investment. This should be figured at a percentage equal to

### A Suggestion

Do your accounts account?

Do they give you real knowledge of your business?

Do you *know* just where you stand in a business way?

If not— isn't it about time to make your books the valuable, practical assistants that they should be and will be if you will do your part?

Make your business books contribute to your business success just as your anvil, hammer and forge do.

What doth it profit a smith if he possess all the knowledge of his craft, and yet knoweth not the reason nor the result of his labors, nor what his labors may bring forth in the coin of the realm?

general smiths have continued to stay in business and live. And this matter of increased costs is a serious one and not a matter of the moment which will right itself within a week or a month. At present there seems to be no end to the continuing rise of prices generally, and under these conditions the sooner the blacksmith, horseshoer and general worker advance their prices, the sooner will

### Sentiment or Common Sense

Many smiths cling to old methods of doing work for the sake of sentiment. Their father, grand-father, or great-grand-father "did it that way" and for the sake of dad and grand-dad they continue to "do it that way". And many smiths can excuse their sticking to old-fashioned accounting and pricing systems only to the same sentimental motives. "It did for dad and it'll do for me" is their slogan. Yet times, conditions and methods have changed. Just as the railroad is better, cheaper and quicker than the old stage coach, so are modern methods of accounting better, cheaper and quicker than the old slate and stub pencil methods.

what the money would bring, if loaned out at interest. The next item is Rent, which must be figured whether or not the Rent is being paid. If the smith owns his own shop, a sum equal to the amount he would receive if he rented the establishment, must be figured in the business expenses. The third item is that of Salary, and this should include not only the salary paid to help, but the salary to which



the proprietor is rightly entitled. Altogether too many smiths consider the profit which they are to receive from the business as sufficient salary for their time and labor. This is not correct, however, if we are to figure our costs in a business way. The fourth item is that of Depreciation. This is another item which the average smith forgets all about. Naturally, of course, the Depreciation on stock and equipment in the average smith is very small, but nevertheless, this is an item that must be figured. Worn out tools must be replaced, worn out machines must be renewed. The ease or difficulty with which the smith will grow and expand may easily be determined by what he charges off to Depreciation each year.

The next item to be figured into the cost of doing business is Donations and Contributions for one cause or another. Subscriptions to newspapers and magazines, dues in business organizations and items of similar expense, which are made for business and not personal reasons. The sixth item includes the Fixed Expenses, such as taxes, insurance, water, light, fuel and similar items. Then come the Incidental Expenses which include postage, office stationery, telephone, advertising and expenses of a similar nature. The next item to be figured into the cost of doing business are the Losses. These of course, increase our over-head cost, and cannot be disregarded. The losses consist of bad accounts, goods stolen, work not charged for and allowances made to customers. The last item to be figured is the Cost of Collecting Accounts. This must include fees paid to lawyers and other collectors who may be employed, also any extra expense connected with the cost of getting the money.

The foregoing items will include practically every expense in connection with the smithing business, but if there are any other expenses incidental to the individual shop, such figures must be added to the foregoing. A total of these nine items of business expense will tell us what it has cost us to do business for one year, as it is, of course, understood that these items are to be taken for one full business year.

To get a correct perspective of the business, however, we must take this figure of business costs and consider it in connection with the amount of business done during the year, as shown by both cash and

credit sales. In order to find the percentage of over-head cost, we divide the total of business expense by the amount of business done for one year, and thus we find the percentage that must be added to the cost of every job, in order to produce a correct selling price. This percentage in the average general smith shop will run all the way from 55 to 75 per cent. Each smith shop owner should determine accurately

hood of seventy-five cents at present cost figures. Suppose then for convenience sake, that sixty per cent is our cost of doing business, or in other words, it costs us sixty cents to do one dollar's worth of business. On this basis to do a two dollar shoeing job, it will cost us \$1.20 in over-head expense. This added to the actual expense of the job involved, will make a total of \$1.95, leaving an actual profit of five cents on a job

#### The National Association of Credit Men recommended the following rules for figuring costs and profits

1. Interest on Investment—Charge interest on the net amount of your total investment at the beginning of your business year, exclusive of real estate.
2. Rent—Charge rental on all real estate or buildings owned by you and used in your business at a rate equal to that which you would receive if renting or leasing it to others.
3. Salaries—Charge in addition to what you pay for hired help, an amount equal to what your services would be worth to others; also treat in like manner the services of any member of your family employed in the business not on the regular pay roll.
4. Depreciation—Charge depreciation on all stock carried over on which you may have to make a less price because of damage, or any other cause.
5. Depreciation—Charge depreciation on buildings, tools, fixtures, or anything else suffering from age or wear and tear.
6. Donations—Charge amounts donated or subscriptions paid.
7. Fixed Expenses—Charge all fixed expenses, such as taxes, insurance, water, lights, fuel, etc.
8. Incidental Expenses—Charge all incidental expenses, such as postage, office supplies, expenses of horses and wagons used in the business, telegrams and telephones, advertising, canvassing, etc.
9. Losses—Charge losses of every character, including goods stolen or sent out and not charged, allowance made customers, bad debts, etc.
10. Collections—Charge collection expense.
11. Other Expenses—Charge any other expenses not enumerated above.
12. When you have ascertained what the sum of all the foregoing items amounts to, prove it by your books, and you will have your total expense for the year; then divide this figure by the total of your sales, and it will show you, the per cent. which it has cost you to do business.
13. Take this per cent. and deduct it from the price of any article you have sold, then subtract from the remainder what it cost you (invoice price and freight) and the result will show your *net profit or loss*.
14. Go over your various selling prices, and see where you stand as to profits, then get busy in putting your selling figures on a profitable basis and talk it over with your competitor as well.

what this percentage is in his own shop. To take any other figures than those shown in your management of your own business, would be almost as bad as guessing at the figure or in charging some one else's prices for work done in your own shop.

#### How to Make Use of Cost Figures

Having correctly determined what our actual cost of doing business really is, how will we make practical use of the figures thus secured? The percentage figure we have tells us what it costs us to do a dollar's worth of business. Let us suppose then, that we want to reconstruct our rates for shoeing. Suppose, for example, that our shoeing price has been \$2.00. The actual cost of four shoes with calk steel, nails and coal figure somewhere in the neighbor-

hood of seventy-five cents at present, and with an over-head of sixty per cent.

This shows roughly how necessary it is to revise the shoeing and general blacksmithing price-list, but you cannot do it correctly by guessing at it, and it isn't a matter that can be done over night. You will need to do some figuring, some digging into the records for the past year, and then you will need to take a firm stand for a fair profit—a fair return on your investment and labor.

#### A Cash and Credit Price

The agreed price list of the "Blacksmith Association of North Inverness" is given below. It will



be noted that the list contains a cash price and also a three-month price, the "cash price" evidently applying in every case where the work is paid for within three months. This scale was adopted by the association and it was further "agreed that any member violating these provisions would be subject to a fine not exceeding ten dollars."

	Cash	Over 3 Mos.
4 New Shoes .....	\$ 1.25	\$ 1.50
4 Shoes, Reset .....	.65	.75
Cart Wheels, complete, 2 1/4, 2 1/2 .....	23.00	25.00
Setting Cart Tires ..	2.50	2.75
Buggy Tires, each ..	.60	.70
New Tires, 1-inch ..	6.00	6.50
New Tires, 1 1/8-inch.	6.50	7.00
New Tires, 1 1/4-inch.	7.00	7.50
New Axles Stubs, 1-inch .....	7.00	7.50
New Axles Stubs, 1 1/8-inch .....	7.50	8.00
New Axles Stubs, 1 1/4-inch .....	8.00	8.50
Sleigh Shoeing, 1 1/2 x 1 1/4	2.50	2.75
Mounting Riding Sleighs .....	\$12 to \$14	\$14 to \$16
Shoeing Wooden Sled	3.50	3.75
Mounting Wooden Sled	7.00	7.50
Grapplins, per lb. ..	.12	.13
Anchors, per lb. ....	.10	.11
Mounting Cart Boxes .. ...	\$6 to \$7.50	\$6.50 to \$8.00
Cart Travellers .....	1.25	1.50
Hoes, each .....	.75	.85
Laying Hoes, each ...	.40	.45
Laying Coulter .....	.75	.90
Bobsleds, complete ..	15.00	17.00
Crow Bars (Iron) per lb. ....	.10	.12
Bolts (iron) cut and pointed, per lb. ..	.07	.08

### The Fable of the Shop Owner Who Was There With the Punch But Not With the Figures

By F. AIRY TALE

There was once a Shop Owner who seemed to have a face value of one hundred per cent and who possessed the earmarks of Double A-1 quality when it came to craft knowledge. His professional learning was such that he could tell forty point carbon steel in the dark and he was able to differentiate between the vagaries or ringbone and epizootic by taking the pulse of the patient and looking at the animal's shoes. His gyrations with the tools of his profession had Father Tubal backed off the map and calling for water, and when it came to artistic productions and difficult welds and forgings, the masters of iron ornament, Cran, Googerty et. al. all were left at the post. In other words, he had 'em all beaten a mile.

But—alas, alack and odds—bodkins—Our Hero, the Shop Owner

was short in one line which makes the well balanced general smith. He was not there with the book stuff. He knew not the what nor the where of costs. Expenses were to him as tales of complaint to a street car corporation—something to know but nothing to be investigated. Time and time again work difficult of manipulation in the extreme, not to say hard of execution, was brought to him for solving and solution. And just as frequently the work was accomplished with the conventional neatness and dispatch to the joy of the customer. But—alas, notwithstanding the oft-repeated bromide that satisfaction and service make the price. Our Hero thought nothing of his accomplishments—nor his time—nor his labor—nor his overhead and in consequence he played a losing game. His intake was not of sufficient volume and naturally the fliver of business was in imminent danger of becoming stalled.

But—oh, joy!—it came to pass upon a certain day that this Shop Owner awoke to his short comings and set about to remedy the defect. Said he to himself:—"You're some punkins in this forge and anvil game, up to a certain point. You can weld a ten-inch shaft or hammer out a rose petal—and when it comes to the difficult stuff you're there with both feet. But—when it comes to getting the mazuma, the long-green and the coin you fall far short of your pedigree and make a fluke that is about as successful as a weld made with sulphurous coal. Along the forge and anvil line you are full of pep and all to the candy but when it comes to desk work you are nix and you miss in all cylinders. It's you for a course at the business college. Hob nob a bit with the intricacies of Debit, Credit and Costs. Rub shoulders with Double Entry and Trial Balance. Polish up your intellect on the Relationship of Selling Price to Over-head. 'Twere better to supplant some of thy knowledge of forging methods and horse anatomy with an inkling of cost accounting."

And even as it was said, so was it come to pass. With the aforesaid acknowledged wise counsel, this Shop Owner studied accounting and installed a system which would tell him everything from the cost of paring a sole to the price of coal per chunk. He also knew who owed what and—from that day he and his family have begun to live. They have been reaping a just reward

from the Shop Owners effort. They have forever banished the vision of the poor house that stared at them from the future. The Shop Owner waxed happy and prosperous and in the scale of success he balanced as a craftsman and a business man.

*Moral—This teaches us that Trade Knowledge is important but that Desk Work is more so.*

### Shoeing Prices Vs. General Smith Prices

BERT J. STOREY

The main issue these days is "Prices" and trying to keep your cost account is like other contending affairs.

From my standpoint it occurs to me that the average smith does not keep in touch with the general price of repairing. We get from 40 to 60 cents per new shoe. The average man can calk and put on 4 shoes in one hour. At \$4.50 per keg for shoes, \$1.75 for toes the cost of 4 shoes is 50 cents. The 50 cents is the actual cost of material taking 50 cents from \$2.00 leaves \$1.50 per hour for labor only.

In "Our last Journal" the Nebraska price list is a joke. Take their own prices, and figure the cost of material out and multiply the actual time by their labor by the hour, 65 cents ("get this 65")—why don't they charge living prices? How can a man make any money this day and age working for 65 cents per hour? They look only to one thing and that is horseshoeing. That is the one big "holler" and they go broke on the general business.

No business can succeed depending on other fellows to establish a price on your work. The Nebraska list winds up by charging 10 cents per pound. My advice to the trade is this: When you receive a bill of goods, take invoice and check off on the cost sheet. For example: If 3 bars of 3/8 by 1 1/2 flat steel costs \$3.00, one bar will cost \$1.00. If bars are 10 ft. long the cost is 10 cents per foot. Get your cost in lineal feet, and charge according to the job you turn out.

Here is an example from my shop: A customer was cutting wheat and broke the drive shaft on his binder. Unable to get a new one he asked me to weld it. While I was working on this shaft, another farmer broke another piece about the same size. The latter was prying out stone. I charged for the binder job \$1.50 and the owner was satis-



fied. while I charged the other customer 50c. I will again emphasize the one error in blacksmithing and horseshoeing. Do not try to regulate your business by the price you charge for shoeing, keep track of your general line and make it pay its way on a profit basis.

### Who Must Stand the Loss of This Fire?

This most interesting case is submitted to me by an Ohio reader of these articles. It is not only interesting, but typical of a condition that may arise in any business without a moment's notice:—

If consistent with your plans, please let us and other readers have your opinion on the following case, which has just occurred in our business. About 10 days ago we placed an order for certain merchandise with a manufacturer in Pennsylvania. The goods were to be shipped on the 12th, and we had received word that they would be shipped promptly at that time. Yesterday we received a letter from the manufacturer in question, stating that he had a fire, which had destroyed a part of his plant, and that our shipment had been completely destroyed. The letter ended with the most astounding statement that "unfortunately, the loss must fall on you." We had never heard of such a case before and at once consulted our attorney, who is looking the matter up now. We should like to have your opinion on the subject, for we cannot believe that under the circumstances we will have to pay for these goods, which will amount to about \$950. Please use no names.

Yours,  
R. E. & Co.

I admit this looks like a hardship, but nevertheless it is quite possible that this correspondent may be liable for the goods. I will discuss the subject generally, so that he may apply it to his own case.

Where the loss falls in this case depends on whether title had passed to these goods. If it had passed to the buyer, the loss is his. If it had not passed to the buyer, it of course was still in the seller and the loss is his.

Whether the title had passed to the buyer, depends on facts which are not given to me. I will state, however, what facts would pass title.

I assume from this correspondent's business that the goods ordered did not have to be made specially for him, but were a part of the manufacturer's regular product.

The law is somewhat different where the goods have to be specially made for the buyer, as I will explain further on. I will assume then that when the order was received, the manufacturer simply then

or later filled it or intended to fill it out of regular stock on hand.

If at the time of the fire the goods to fill this order had been separated from the mass of stock, and set aside for this buyer, and if they were all ready to ship—nothing more to be done on them except to ship them—then I should say that title had passed and the loss was the buyer's. This provided it was not a cash transaction. In spot cash transactions, title does not pass until the cash is paid.

But understand clearly that the



MR. HARRY M. BROWNING

goods must have actually been set aside or separated in some way, and must have been ready to ship. If they were still a part of the manufacturer's general stock, title would not have passed even though they were paid for. There is a well-known case in which a buyer ordered nine hundred tons of iron and paid for it in advance. The foundry was destroyed and the question arose—whose was the loss? It was decided that it was the seller's. Although he had gotten his money, the title to the nine hundred tons of iron had not passed to the buyer because it had not been separated from the mass of iron in stock.

Besides being separated from the mass, something else must also be true—nothing else must remain to be done to the goods before they are shipped. For instance, suppose a packer of canned goods sells

a thousand cases of tomatoes. All the cans necessary to fill the order have been piled up by themselves on one side of his factory, but they still have to be put into cases. In case of fire the loss is on the packer, because while the thousand cases were separated from the mass, something still remained to be done on them. Title cannot pass until the seller completely performs his contract, which he would not do until he had packed his goods in cases ready to ship.

There is one exception to the rule that title does not pass until the goods ordered are separated from the mass—grain. All States agree that the owner of a part of a mass of grain has title to it and can part with it without separation from the mass. And a few States (Florida, Iowa, Kansas, Minnesota, New Jersey, New York, Texas, Virginia and Wisconsin) have some cases which hold that where the sale is of a part of an *identified* mass, no separation is necessary in order to pass title. For instance, in one Virginia case a man sold 119 barrels of flour out of a definite lot of 123 barrels. Before delivery, or even before the 119 barrels were separated from the 123, there was a fire, and the question 'whose was the loss' arose. The court said it was the buyer's, for the sale was one of a part of an identified mass and title had passed.

This, however, is not the weight of authority, and in all other States the courts would hold in the flour case that as there had been no separation of the 119 barrels, title had not passed and the loss was on the seller.

I should show the distinction that exists where the goods to fill an order are to be specially manufactured. In that event of course title does not pass until they are completely finished, and not even then if the buyer is to have the privilege of examination before acceptance. If in the Ohio case the goods were to be specially manufactured, no title would pass until first the manufacture was complete, and second the goods had been inspected and approved by the buyer.

(Copyright by Elton J. Buckley.)

### A Great Horseshoeing Plant

One of the world's great horse and mule market is the National Stock Yards at East St. Louis, Mo. What is more natural than to find a great horseshoeing plant located there? With a force of some thirty



men this big St. Louis shoeing shop is said to put the metal foot-wear on between 600 and 700 animals a day.

Harry M. Browning, is the name of the owner of this shop, where, at present at least, more horses are shod than in any other shop in the world. Browning, only thirty-two years old, started at the anvil at the age of seventeen. He passed through the stages of apprenticeship and journeyman and six years ago opened his own shop. After a year in his own "one-man" stand a group of horse traders at the National Yards (friends of Browning) induced the young horseshoer to take charge of the shoeing at the stock yards. This business has always been a flourishing and profitable one, but, during the past few years or since the volume of business of this great horse and mule market has taken a tremendous jump, has increased many times.

In this shop ten fires are going constantly, while at the anvil in front of them, ten men do nothing all day long but put calks on shoes. Twenty other men do nothing but shoe horses. This work goes on every day in the week, including Sundays and holidays. At present in Browning's shop between 600 and 700 horses are said to be shod every day, and some 1500 horseshoes are used daily. The apparent discrepancy in the figures is due to the fact that the dealers for whom these horses are shod are required to have only the two front feet of the animal protected by metal. This requirement is made because in the long journeys in stock cars and in cattle ships, if the animals who are sent abroad, the horses, if shod on their hind feet might injure and maim one another by kicking.

Some idea of the vast amount of horse shoe nails consumed in this shop can be obtained from the fact that each shoe for these animals requires six nails, and at the rate of 1500 shoes a day this would mean the use of 9000 nails daily. And the requirement in nails alone for a month or a year is almost unbelievable.

Naturally the danger element, which is always present in every horseshoeing establishment, even in the regular custom shop where the animals are usually well known to the shoer, is multiplied many times in the Browning shop because of the fact that every animal is unknown as far as disposition and training are concerned. Yet while some extremely wild animals

have been shod Mr. Browning says that accidents and injuries have been very few. His men are the best and most experienced that he can secure, and when necessary, two or three of them will work on one horse.

Since the tremendous increase of the horse and mule trade during the past few years, it is estimated that somewhere in the neighborhood of

corns. This foot has little expansion under any conditions, and a little more contraction than it naturally possesses causes the thick walls to crush the sensitive tissues between themselves and the heels of the pedal bone. These feet are usually more upright and of steeper or more obtuse angles and therefore greater concussion is engendered and in consequence wind

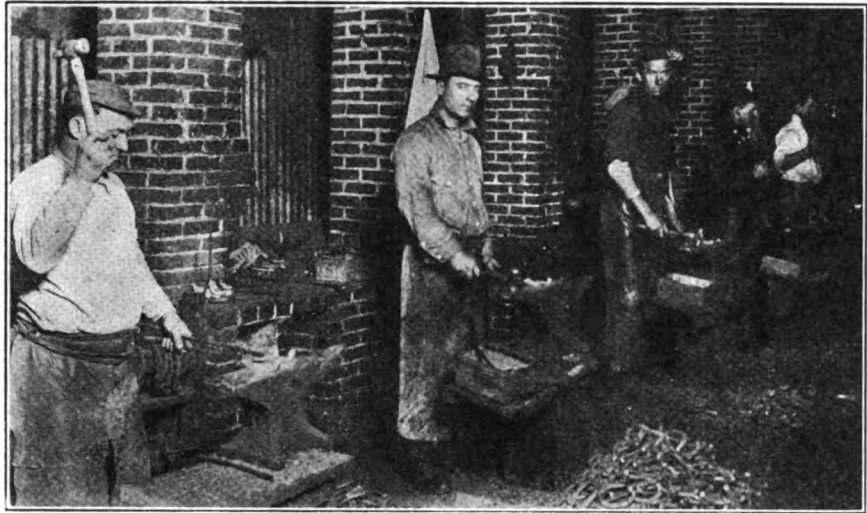

ONE SIDE OF MR. BROWNING'S HOESHOEING SHOP SHOWING A FEW OF THE FORGES

three hundred thousand horses and mules have been shod at the Browning shop. These horses have been shipped to practically every corner of the globe.

### The Three Types of Horses' Feet and How They are Shod

A. L. CAMP

The feet of the horse are of three types which will be referred to by the numbers 1, 2 and 3, respectively. No. 1: The small thick-walled foot of compact fibre, with sole highly arched or concave, and small frog set well above the ground bearing of the heels. No. 2: The medium sized foot with moderately thick wall, sole slightly concave and a well-formed rubber-like frog. No. 3: the large thin-walled flat soled foot with abnormally large and fleshy frog.

As a rule, numbers 1 and 2 belong to the higher breeds inclusive of the thorough breeds, the standard breds and the nondescript drivers, saddlers and cow horses of the west; while number three is the foot of the draft breeds.

Foot No. 1 is more liable to that form of contraction productive of

puffs are more common than in the other kind of feet. Feet of this sort should not be kept shod more continuously than is absolutely necessary. In fact they may be left unshod a greater part of the time on dirt roads with benefit to themselves, as their thick walls of compact character stand wonderful wear.

Feet of this kind are possessed by horses whose ancestors have for generations been bred in arid regions and are evolved from the conditions of the semi-deserts whose dry and rock covered hills and sandy flats are ideal for the arched sole, the small high perched frog and the upright hoof and pastern. Of such resistance to wear and breakage are these feet that but few of the cow ponies of the West and Southwest ever need shoeing and a majority pass their lives of almost continuous riding, unshod. I have known of two farm horses, partly of this breed, whose feet inheritance was of this type and which died at sixteen and twenty-seven years respectively in Colorado, which were in constant use on the farm and road from colthood and yet were never shod and were neve tender-footed.

As a rule the race horse having this type of foot, whether it be harness horse or runner does not last



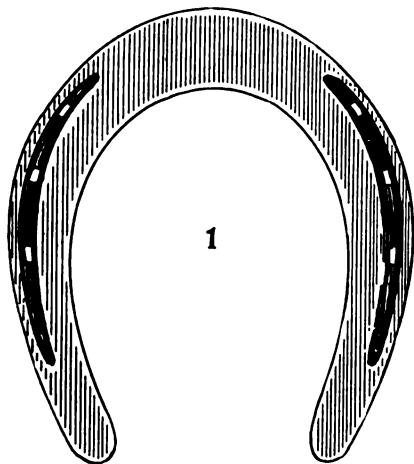

SHOE NO. 1 FOR THE SMALL, THICK-WALLED FOOT

many seasons on account of concussion. Corns or bad ankles with the attendant pain or stiffness curtailing their flexibility causes loss of necessary speed.

Foot No. 2 has a moderately thick wall with a slightly concaved sole and a well defined rubber-like frog. This is the ideal foot on the farm or dirt roads as it has reasonable wearing qualities. It must be kept more constantly shod than No. 1, but is more resistant to the evil effects of the shoe for it possesses in a high degree the essential qualities of expansion and contraction upon which the welfare of the feet are dependent. Its frog is alive and rubbery; usually free from excessive dryness or the sponginess conducive to thrush. It may reasonably be expected that feet of this type, no matter what use their owner is subjected to, will remain sound for the life time of the animal.

Type No. 3; the largest flat foot is the worst of the three. Unlike the possessors of the cupped feet of dense texture whose owners have fed for generations on the dry and nutritious grasses of the arid regions—feet that knew naught of moisture save the slight dew of morning or the momentary splash of the stream's quick crossing—the flat feet are products of wet lands and watery grass; they are soft and loose fibred. The weak walls give way to the outward pressure of the sole which descends until it bears weight which was never intended for it. The frog is large, spongy, and soft and extremely inviting to the inroads of thrush. The flat sole easily separates from the wall and its layers from themselves and canker is a common ailment.

While foot No. 1 is all too subject

to contraction causing corns, yet this oppositely constituted form (No. 3) is subject to more and worse afflictions. For wherein the first named contracts at the base. The latter expands there but sympathetically contracts at or just below the coronet, bruising the lateral cartilages and thereby producing the side bones which are so common to this type.

In shoeing, for best results; No. 1 should not be too closely dressed. In fact plenty of wall for ground bearing should be left that the shoe may not come in contact with any portion of the sole. For in as much as the tendency of this foot is to contraction and as either frog or sole pressure is conducive to this, such should be avoided. The shoe should be thick vertically and narrow of web, that the central

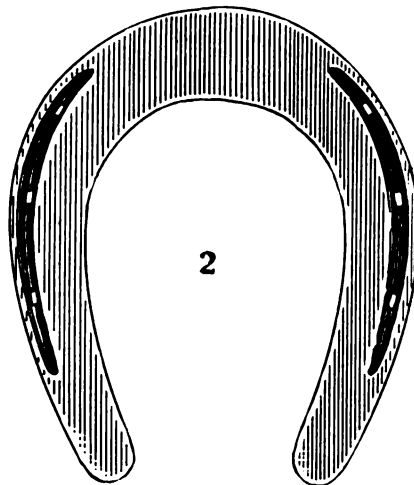

SHOE NO. 2 IS FOR THE MEDIUM SIZED FOOT WITH SMALL FROG

parts composed of frog and sole may have the utmost possible freedom to rise and descend. The nail holes should be six in number and set forward as far as possible. With the thick, strong wall the nails will get a deep firm hold and if no nail is back of the center of the foot's length, the shoe will hold tenaciously. This hoof should be of greater height than numbers 2 and 3 from coronet to base. This will not inconvenience the animal, for the strong short pasterns and the obtuse foot-angle minimize the power used in breaking over the toe and flexing the pasterns.

The shoeing foot No. 2, whose wall is of thinner horn and the sole less pronounced in concavity with a fairly wide heel, must be decidedly different from No. 1. The angle of this foot is more acute owing to the expanded heels. The angle is

naturally about 45 degrees which is the ideal for perfect and sound feet. The walls are more slanting from coronet to base than in No. 1. This foot should be shod with shoes of wider web than No. 1 and the material should be thinner with nail holes punched well to the middle of the web and the nails driven low. The rear holes should be nearer the heels as this foot does not hold the shoe near so securely; neither should so much wall be left on No. 2 as on No. 1 for expansion is, if anything, more liable that contraction. A long toe is entirely out of place on No. 2 because of the more acute angle, the greater slope of the pasterns, and the consequently more pronounced leverage to be overcome in their manipulations.

Foot No. 3, is the hardest proposition the shoer has to tackle. The flat sole is practically resting upon the ground,—the walls are flaring thin—the frog is abnormally large, spongy and moist, and there is certain to be an accompaniment of thrush, canker, side-bones or at least their menace of such from the compression of the upper wall against the lateral cartilages.

This foot is usually acute of angle—much more so than No. 2; some feet show an angle of as much as 40 degrees. The weight of the animal is borne more upon the heels than the toes. The shoe should be very wide of web and of thin material; so wide in fact that a large part of the sole be covered. Short heel calks to raise the frog from the ground are not amiss here. If toe calks are used they should be well set back from the toe that the break-over be made easy. Eight nails are needed for each shoe and should be driven

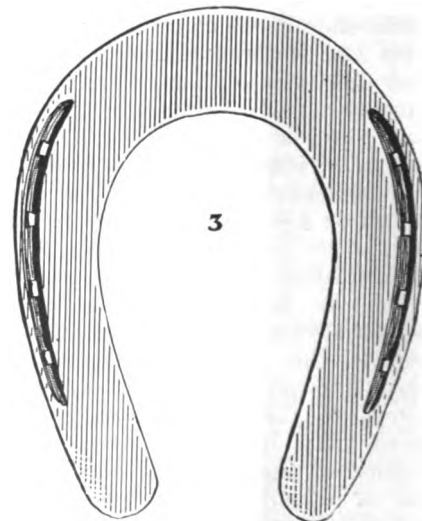

SHOE NO. 3 IS FOR THE LARGE THIN-WALLED FLAT-SOLED FOOT



low in holes punched in the middle of the web with the rear nails as near the heels as possible, for this foot does not hold a shoe well. The less often this foot is re-shod the better. I should say that 90 days is, as it has to be kept shod—the longer the same shoe remains the better. I should say that 90 days was often enough to re-shoe if the shoes will last so long.

I stated above that frog and sole pressure induced contraction, and yet am advocating that this foot whose tendency is expansion that the frog be elevated. This seems contradictory, but is not so, for the reasons that the foot is too weak to stand the subjected pressure without injury from bruises to the sensitive tissues on the upper plane of frog and sole, and further, the uplifting of heels by the calks not only prevents the aforementioned bruising, but make the angle steeper.

The engravings show the kind of shoes suitable for the three types of feet.

### Shoeing for Quarter Cracks

A. G. GILBOY

Quarter-crack is usually accompanied with contraction and corns, and generally occurs on the inner quarter of toe wide hoofs. In dressing the foot for quarter-cracks I pare the hoof lower on that side which the crack is on and see that the shoe does not touch the quarter. When the shoe presses on the quarter or the hoof grows out so there is pressure, the shoe should be removed and the foot dressed so as to keep the shoe off the quarter. I use a bar shoe with leather and tar and oakum for sole packing. I have also used a half-bar shoe to good advantage. Shoeing with a rubber hoof-

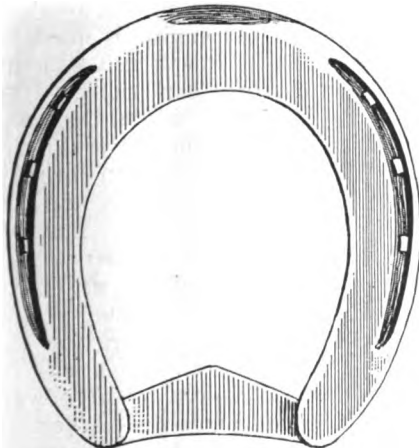

THE BAR SHOE IS USED WITH LEATHER PAD AND PACKING

pad gives good service, for through a rubber pad the body-weight is distributed over the sole and frog, and it assists in widening the hoof while the shock is lessened when the foot strikes the ground. The main object is to do all we can to grow down the unbroken horn. I have used a plate of brass with small screws to hold the cracks in place and cut away that part of the wall so no pressure will be under the crack. I also cut across the wall at the coronet, and thin the horn for an inch or so on each side of the crack over the coronary band. The accompanying engravings of shoes and hoof with crack show my way of treating cracks.

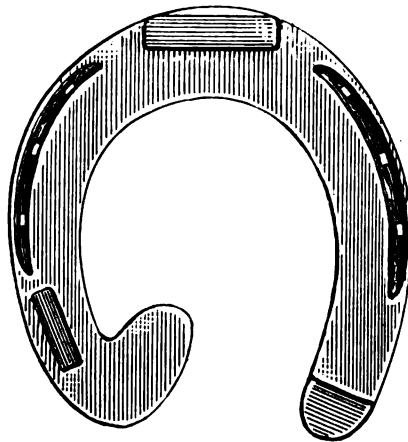

THE HALF-BAR SHOE IS ALSO USED TO GOOD ADVANTAGE

The photograph on page 114 shows a case of shoes for different cases of foot trouble.

### Gas Engine Operation Made Simple—5

The Purchase, Installation, Operation and Troubles of a Gas Engine.

J. L. HOBBS

The office of the cylinder is to produce the explosions or rather to transmit the power produced by the explosion to the crank axle. In the chapter on Compression the cylinder, piston, rings, valves etc., are taken up and carefully explained.

The exhaust valves of all engines are operated mechanically. The intake valves on some engines are automatic, by automatic is meant they are opened by the suction of the piston and closed at the end of the suction stroke by a small spring just strong enough to operate the valve, and yet not offer any great resistance to the suction stroke of the engine.

The exhaust valve is opened by a small cam or excentric on the cam

shaft coming in contact with a push rod in such a manner as to push

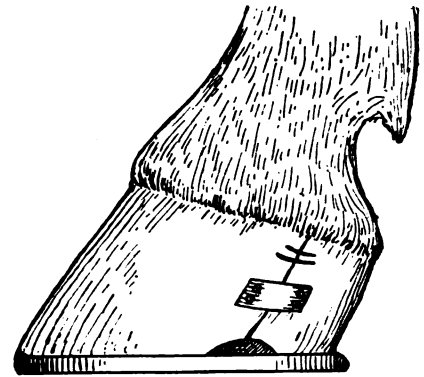

THE EDGES OF THE CRACKS ARE HELD WITH A BRASS PLATE

open and hold the exhaust valve open during the exhaust stroke of the engine, it is closed by a spring. The exhaust stroke begins just as the power stroke has been completed and lasts while the piston is traveling the full length of the cylinder. Where the intake valve is operated mechanically it is done in the same manner as the exhaust, only the intake valve opens just as the exhaust valve closes and remains open during the time the piston is passing back to the other end of the cylinder on the suction stroke. This is what is called the timing of the valves, and is a very important operation in regard to an engine.

The cam shaft which operates the valves is in turn operated by a gear on the crank axle. The cam gear has just twice as many teeth in it as the crank axle gear which makes the cam shaft rotate only once while the crank axle makes two revolutions. For the purpose of taking apart and reassembling an engine, these gears each have a tooth marked to enable the operator to take apart and put them back together in the same position. In taking an engine apart always be sure that these gears are marked before separating them, as you will save yourself quite a little bother by so doing. It is splendid practice in tearing an engine apart to mark everything that you are not absolutely sure you know about as it will save you lots of time in reassembling.

If the cam shaft should be taken out without looking for the markings and no markings should be there, the following will guide you in replacing the gears in proper mesh. Set the crank axle on dead center with the piston as far into the cylinder as it will go, then turn the cam shaft until the little cam

which operates the intake valve is just ready to open that valve and you have it. If the intake valve operates automatically then turn the engine to outer dead center and turn the cam which operates the exhaust valve so it is just ready to open the valve. You may miss this a tooth or two, but by a little experimenting you can get the exact notch. It is not a hard job, only use judgment and patience.

Gas engines are of two kinds, scientifically called two cycle and the four cycle engine. To use plain english a two cycle engine is one that makes an explosion at each revolution of the crank shaft and a four cycle engine gives an explosion at each alternate revolution of the crank shaft.

The four cycle engine is the one almost universally used and by explaining the workings of it first the other becomes simpler. A four cycle engine is so called because it requires four operations in order to produce a power stroke. The suction stroke is when the piston passes out towards the crank shaft when the intake valve is open, this allows the cylinder to be filled with gas from the mixer. The intake valve closes at the end of this stroke and the piston coming back against this charge, by the weight of the fly-wheels compresses this mixture into a small space in what is known as the explosion chamber. This is called the compression stroke. The igniter is tripped just as the compression stroke is completed, the charge is fired and the piston is forced out of the cylinder transmitting the power to the crank axle through the connecting rod. This is called the power stroke. Just as the piston reaches the end of this outward stroke, the exhaust valve is opened and the exhaust stroke commences and is continued until the piston gets back to the inside center again ready to take up the suction stroke. This is the exhaust stroke. The four strokes then necessary to produce one impulse on the crank shaft are suction, compression, power and exhaust. If you understand these four motions you have gone a long way towards solving the mysteries of a gas engine.

In a two cycle engine the intake stroke and the exhaust are both eliminated making only a compression and a power stroke necessary to get the impulse on the crank shaft. To eliminate these two strokes it is necessary to have either an

auxiliary cylinder in which to compress the gas so that it can be forced into the cylinder without the suction stroke, or in some makes of engines the crank case is made air tight and the piston on the compression stroke sucks the gas from the carbureter or mixer and when the piston starts out on the power stroke this gas is compressed in the crank case, and when the outer end of the power stroke is reached, a couple of ports in the side walls of the cylinder uncovered and the exhaust rushes out at one and the gas in at

take ports being open at the same time, there is a noticeable loss of power in proportion to what the four cycle engine will develop from the same amount of fuel.

The two cycle engine has the distinct advantage of being of much less weight and bulk and is very desirable where space for installing an engine is limited, as in boats, etc. This type of engine is very popular on motor boats and other uses of this kind where weight and space are a deciding factor in the selection of an engine.

The working of the igniter and timer and other kindred subjects will be taken up in the chapter on Ignition and there made plain.

The timing of a gas engine, or rather getting operators to understand the timing of an engine is the hardest thing to contend with. It would not be out of the way to say that nine out of ten engines observed have been out of time, and the majority of these have been timed so slow as to interfere seriously with the power. We will try here to make this plain. An engine must be timed so that the explosion takes place just as the inside dead center, or the dead center farthest from the crank axle is being passed. Now remember it is the explosion that must take place at this time, not the ignition. In order to get the explosion at this time, the igniter must be set ahead of this time to give time for the explosion to take place. This time must be varied in accordance with the speed of the engine. For instance, a heavy slow moving engine can be timed for the ignition to take place about  $7^{\circ}$  to  $10^{\circ}$  ahead of dead center, while a one horse high speed engine can be timed for the ignition to take place as much as  $45^{\circ}$  ahead of dead center. There is no definite rule to go by, but in order to get the greatest power out of the engine it must be timed as fast as it will run without having premature explosions. Just bear in mind this one thing, and that is, it is the explosion that must take place just as the piston is ready to start on its outward trip, and not the ignition. If you set the ignition to take place at the commencement of the stroke, the piston will have moved outward and some of the compression be lost before the explosion takes place, which will of course be detrimental to the power. Steam engineers are the hardest to teach the timing of a gas engine. They want to time them just the

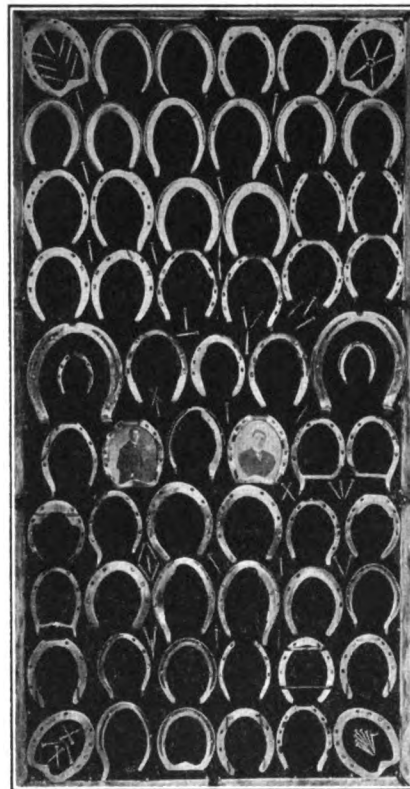

MR. A. C. GILROY'S CASE OF SHOES FOR DIFFERENT FOOT TROUBLES

the other. The ports are covered again and the compression stroke begins. Where the extra cylinder is used it must work just the opposite to the piston of the engine in order to deliver the gas to the cylinder at the right time and under pressure.

The igniter trip or timer is operated by the cam shaft on a four cycle engine, but by the crank axle on a two cycle engine. The reason for this is that in a four cycle engine an ignition is only necessary once in two revolutions, while in a two cycle engine, an ignition is necessary every revolution. The two cycle engine would seem to be the simpler of the two, but owing to the fact that there is a slight mixing of the burnt gases in the fuel mixture, on account of the exhaust and in-



same as they would a steam engine, and in doing so lose about 25% of the power. It is astonishing what a difference there is in an engine which is timed right, and another just like it which is timed too slow. There is no comparison in the power of the two.

(To be continued)

## Oxy-Acetylene Welding Hints

J. N. BAGLEY

Competition is more keen every day and it behooves the smith to get lined up on every line that will boost his business, providing the outlay is not more than he is able to stand. The cost of the welding machine is, at the present time, within easy reach of any smith who would care to have one in the shop. Many concerns are selling on the installment plan and this eliminates the putting up all cash, which many of course appreciate, especially if capital is limited.

Just what machine to buy depends on the choice of the smith for there are many machines on the market and most of them good, for no manufacturer can put out a poor machine and expect to stay in the business any length of time. It seems that the most used machine is the machine having the storage tanks filled at a service station, that is, getting the drums of oxygen and acetylene gas filled at the filling station and returning them when empty, thus simply exchanging the empty drums for the full ones and paying for the gas that is in them. All outfits on the market today are fitted with gauges and connections for using these tanks and for the small shop this outfit will be the better. The larger outfits generating the gases as used are found principally in the larger shops.

The cost of the outfits as described range from \$35.00 to \$75.00 depending, somewhat on the size etc. There is considerable in the gauge equipment and these things should be taken into consideration in making the purchase. For instance, an outfit may be put out with nothing but reducing gauges, that is they reduce the tank pressure to say twenty or thirty pounds as desired. Then there is the combination gauge outfit which not only reduces the pressure to the desired pressure, but another gauge gives the reading of the tank at all times. This one feature is not absolutely necessary,

but it is very convenient because of the fact that the amount of gas remaining in the storage tank is known at all times. Then the torch equipment has much to do with the price, for there is a great deal of difference in torches, as one will learn as he begins to use them. In the first place there are torches of the same capacity, one using considerable more gas than the other on the same job, and this should also be taken into consideration.

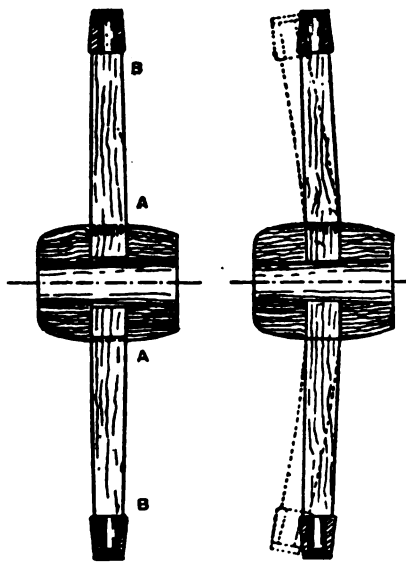

WHY IS A WHEEL DISHED

Some of the outfits are equipped with a cutting torch which of course will advance the price from fifteen to forty dollars, depending somewhat on the size and construction. A cutting torch is a very useful tool and no welding outfit is complete without it, as it can be used to great advantage in cutting large shafts or plates. Then again it is handy for cutting beams, or wrecking steel structures of any kind. It is very useful in wrecking automobile frames when junking cars as rivets can be sheared quite fast, without, however, damaging the channel iron of which the frame is made. The ordinary torch can be used for cutting small plates and shafts, etc., but it is very unsatisfactory because of the fact that the edges are rough to say nothing of the waste of gas in the operation.

If the machine is to be portable, the first thing to do after receiving it is to make a suitable truck to move it about. A very handy one can be made which resembles very much a small truck used in a stock or storage room. The two tanks can be placed on it and the balance of

the supplies can have a corner where they can be close at hand. The cost of this truck will be very small for it can be made and welded up after the machine has been set upon the floor. It is a very good idea to make the entire truck of angle iron or some other iron, for in case it is made of wood there is a possibility of it being burned.

Then next in order will be a table on which to do the welding. The top should be a planed surface for it will save a great deal of time in lining up work that must be kept straight. Something of this sort can be found around most every shop, and in case it cannot, it can be ordered from any of the heavy hardware houses from which the smith buys his goods. This can be mounted on trucks, or legs as desired, but the truck is best as it allows of moving about to meet the condition.

The welding of the steel will probably bother the beginner more than all other metals with which he will have to deal, because of the fact that to get a good weld the steel must be heated to just the proper temperature, and have the gases regulated correctly. The first thing to do is to be able to tell whether or not the steel is in a molten condition or burning. In case the flow of acetylene gas is excessive, the steel as well as the rod will carbonize and have practically no strength at all. On the other hand, in case the flow of oxygen to the tip is too strong it will have an effect on the steel which is known as oxidizing it. This as well renders the steel useless. This fact will be found in welding all metals, but quite a little more noticeable on steel than any of the others. The flame may be adjusted to show absolutely neutral to the eye, but it can yet be either too rich with either of the gases, so the proper and sure way is to be able to judge the flame from the manner in which the metal performs under the heat of the torch.

Now if the operator will melt a piece of steel with the flame containing a noticeable excess of acetylene, he will observe the way it boils, with large white bubbles on the surface. Next try using the torch with the excess of gases reversed. Now there seems to be a white froth, so to speak, which resembles the froth from an animal's mouth, or much like soap suds with a slight tinge of dirt in it. Either of the welds made with either gas in excess will leave



a joint without strength and be absolutely useless so far as strength is concerned. After a little experience one will be able to tell from the manner in which the steel flows whether or not it is flowing as it should. (To be continued)

### Why a Wheel Is Dished

Editor's Note:—The following from an English exchange (Work) while on an old subject that has been discussed ever since wheels have been built in their present form, will interest every vehicle worker.

Whether or not the design of the vehicle is adapted for dished wheels, and that is—an upright wheel is rigid, a dished wheel has a certain amount of spring, consequently a tire will remain on a dished wheel an infinitely greater time than it will with one that has the spokes at right angles with the centre of the hub. This is due to the well-known laws of expansion and contraction. The iron tire lengthens in hot summer weather and shortens in cold weather. On the other hand, the timber of the felloes and hub shrink in hot summer weather and swells with wet in winter. Consequently, with an upright wheel on a cold day, the ends of the spokes are forced into the felloes and hub as shown at A and B (Fig. 1) by the contraction of the tire, and the swelling of the timber at the same time leaves a permanent housing of the shoulders at the tang and tenon which permits the tire to become loose when it expands with a change of temperature, and if this is accompanied by dry weather, the shrinkage of the timber makes matters worse. Now as long as a tire is tight, even if the timber is old and poor, the wheel will run safely; but work it with a loose tire, even if this is held on with nails or bolts, and the wheel will soon get beyond repair.

With a dished wheel the contraction of the tire, instead of forcing the shoulders into the hub and felloes, simply bends the spokes as shown by the dotted lines in Fig. 2. Consequently the wheel is slightly more dished on a hot day than a cold day. When a wheel is made, an allowance is given for the tire to pull it a little more into dish. Consequently there is a certain amount of initial stress on the spokes which give and take with the tire changes and the load. In an upright wheel, the spokes are struts; in a dished wheel they act as combined struts and cantilevers. When a vehicle is loaded, the tend-

ency is to distort the wheel to an oval form; but any distortion of this kind on an upright wheel could only take place by forcing the top and bottom spokes into the felloes, leaving the horizontal spokes loose at the shoulders. With a dished wheel, the vertical spokes bend a little more, and those that are horizontal lose a little of their initial bend. Moreover, the spokes in a well-made wheel are especially shaped to give the maximum of strength with the minimum of weight under these conditions.

The probable reason why wheels were dished in the first instance was to allow for a greater loading space at the top, without interfering with the track of distance between the wheels on the road. This was a very important point in the old days, when all vehicles had to keep to the rut or turn over, and when the superiority of a dished wheel had been demonstrated, it came into general use.

Our present-day wheel has taken some 4,000 years to develop, and the only real improvements in modern times is the introduction of the artillery hub and the rubber tire. For a record of the failures to effect improvements, one has only to call a patent office library and look up the old specifications.

### Thoughts on Timely Topics

By THORNTON

*Some sweet young thing* (oh, we know it by the perfume on the pink envelope), mistaking this column for the agricultural department has written in to ask: "What species of oats are wild oats? Are they analogous to the wild uncultivated pear and similar so called wild varieties of horticultural products?" Naturally this had us floored and out for the count. But as you must needs observe, we have recovered sufficiently to spoil a few reams of perfectly good white paper in an effort to put our fair questioner on the right track.

In the first place we want to say "Lucile", that wild oats have no relation what ever to the so-called tame variety. Tame oats are sown in the fields in the country, as you no doubt well know, while the wild variety are sown along the great white ways and usually between the hours of midnight and dawn. Crops of the wild variety may be put in earlier than midnight, but you may be sure that the crop isn't

of the extreme wild character which distinguishes the later season variety. As in the case of all modern agricultural work, machinery has come to the aid of the wild oats sower. And most excellent aids to the sowing of a good crop are two labor-saving devices known as the limousine and the taxi-cab. It is said that a few earnest toilers with a taxi-cab (which is a decreet fliwer with a cash register attachment) can, if the taxi is speedy and the driver reckless, sow enough wild oats in one evening to reap a court reprimand, a name that the family will be ashamed of and several decades of unalloyed remorse. The sower of wild oats is usually distinguished from the sower of the tame variety by the loud-speaking garments which he affords and by the cigarette deftly held pendant from the south east of his food intake. A s.o. w. o. with these characteristics usually indicates his mastery of the art to all within ear shot and there is no mistaking his vocation nor the thoroughness with which he attends to it. One writer describes the sower of wild oats as: "A dress suit with a weak mind and a strong back."

*The Lowly Bean* has come into its own. Yes, this is going to be another spasm on the high cost of living. There are none of us so young but who can remember back to the time when the bean, the the well-known common white bean, was just an ordinary grocery store product kept in bushel baskets and sold by the quart at from five to eight cents per qt. And quensi-contly pork and beans were the common Saturday chow of millions of families. Now-days the story is different, in fact it can hardly be told. Friend wife, in the course of her marketing tour, thought that a jar of the feed that made Boston famous, would be welcome proven-der for the family generally. So with the idea of providing the necessary material to put the old bean jar into proper operating condition she, included a quart of the common white pellets. Imagine her surprise, mortification not to say chagrin, when the Knight of the sugar schoop informed her that "beans are twenty-five cents per quart." Great shades of Boston! what are we coming to? Beans, the lowly, common, farm product that a few years ago was considered common food—twenty-five cents per quart! Why at that rate it will require a young fortune to stock a



fair sized bean jar for the once-around in an averaged-sized family of fair appetites. The pork trimming for a mess of beans has been costing more than the beans for these several months but now with beans joining the aviation corps, the pork and bean combination becomes practically impossible to the average mortal. And yet the folks who have taken it upon themselves to issue words of guidance and advice to the uninitiated are advising the common people to cut out the luxuries, to purchase only the necessities—and, let me ask haven't potatoes and beans been the necessities of the food table for lo these many centuries? Today you can hardly see them, they're so high. Truly, these are remarkable times for those who must eat but have not the wherewith to purchase.

Your prices—have you advanced them as you should? If you haven't, just read the preceding spasm on beans and then consider where you get off in this price-raising matter. An analysis of shoeing costs at present prices for materials shows that the average job of shoeing will cost all the way from one-fifty to one-seventy-five. And at that rate, where does the shoer stand who shoes for two dollars or less? Chances are he'll stand bare-foot if he keeps on. And in other lines practically the same thing applies. Costs have gone up to such an extent that the smith cannot possibly continue at old prices and survive. He must advance his rate for work if he is to live with his materials advancing, the cost of living on the up-grade, it is but natural that an advance be made in smithing prices. And when an advance is made, see that it is right. Let a proper and correct price be made—one that will take care of the advanced cost of material, labor and everything else and leave a proper margin of profit.

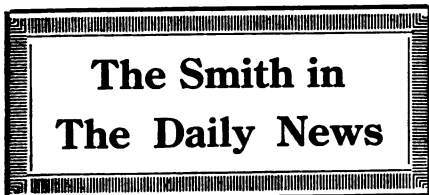

**Blacksmith Wins Pole Fight**

Morris Case, of 4606 Umbria Street, Philadelphia, won a battle yesterday against the telephone company that attempted to plant a pole in front of his blacksmith shop. When the men started the hole for the pole, Case protested. In

spite of his protest, however, the work continued.

Morris Case, Jr., inspired by a happy thought, ran the automobile of his father over the hole and impeded the work. A policeman ordered the car away. When the elder Case refused to comply, he was marched off to the Manayunk Police Station, but was immediately discharged by Magistrate Price.

When he returned to his home he got a chair and sat over the hole. The telephone company surrendered. The pole will be planted in another spot.

"There is one pole in front of my property," said Case, "and that's enough."

**Champion Horseshoer**

Stephen Lovejoy, who has been a blacksmith in Auburn, Me., since 1876, is believed to hold the record for speed in shoeing horses. He has shod three horses in 37 minutes—one in 20, one in nine and one in eight. Half an hour is regarded as quick time to shoe one horse by most blacksmiths.

**Favorable Comment for the Smith Shop**

The blacksmith shop of Parker Moore, recently moved from the Stewart property at Fifth and Delaware streets, Wilmington, to Sixth and Harmony streets, adds much to the appearance of that place with large, well-cleaned windows, and makes now an ideal workshop.

**Blacksmith Sells Scrap Pile for Big Price**

For the past year J. J. Nealon, a "Bucktown boy," better known as "Jack" to his legion of friends throughout the city, and who conducts a blacksmith shop in the 200 block of Raymond court, Scranton, has been endeavoring to have some one remove a large quantity of scrap iron, in the form of old horseshoes, from the rear of his shop, as it was taking up valuable room. was of no earthly use to him, and if disposed of would command only a trivial sum. Several times within this period he endeavored to have the scrap carted away, but no one seemed to relish the job, even though Mr. Nealon offered to pay a worthwhile sum for its removal. During this period the scrap had been increasing until the yard in the rear of the shop resembled a scrap iron storage plant.

When he saw that he could not have the iron removed he decided to hold on to it, as iron has considerably increased in price within the past few months. A few weeks ago a junkman came along and offered Mr. Nealon a good price for the scrap iron, but he refused to sell at that figure.

Yesterday the same junkman called at the shop and came across with the price Mr. Nealon demanded. In payment a certified check for the sum of \$1,000 was tendered to Mr. Nealon for his scrap iron. When seen by a news reporter he was on his way to the bank with the check, with his face wreathed in smiles over his good fortune. Calling the reporter aside he displayed the check and remarked "this is in payment for the yard full of horseshoes I was telling you about recently, which I could not give or even have hauled away. It pays to stick for your price," he added.

Some few months ago Mr. Nealon promised a certain number of his fellow diners at a prominent restaurant, not a stone's throw from his office, that if he disposed of the shoes at the price he demanded he would be the host at the best banquet ever "put across" in this city. These same friends are now awaiting with anxious expectation for the banquet.

**Blacksmiths Continue to Raise Prices**

The blacksmiths of Orange county, California, are feeling the pinch of high prices along with others. At a meeting of the Orange County Blacksmith Association at Carl Prassell's shop at Anaheim, the advancing prices of materials used was discussed. It was predicted that the blacksmiths will have to increase their prices very soon.

A new advance in the blacksmithing materials has been announced to take effect the first of the year. On shoes the advance amounts to 90 cents a hundred, on coal, \$4 a ton, and on all steel and wrought iron, from 50 to 90 cents a hundred.

At a meeting of horseshoers of Wilmington, Del., an increase in the price of horseshoeing was decided upon, the increased cost of iron and steel being given as a reason for the advance. It was decided to increase the price of horseshoeing twenty-five cents a set, and the price of rubber and leather pads also was increased twenty-five cents a set.

The shoers say the shipment of horseshoes to Europe for horses in the war and the mills using steel to make munitions has caused a scarcity of shoes and they say a further increase will have to be made if the wholesale price of shoes and of pads is advanced materially.

At a meeting of the Queens County, New York, horseshoers the following resolution was agreed upon:

"Resolved, that by reason of the increase in wages and the shorter hours of labor demanded by employees, and the increase in the price of materials which approximates 100 per cent., it has become necessary to increase the price of Horse Shoeing, and on and after Jan. 1, 1917, the price per set will be \$2.50, steel shoes, \$3."

Because of the increase in the price of metals used in making horse shoes, the prices of horse shoeing has been increased by the Lima, Ohio, horseshoers. The great demand for metals by the European nations engaged in the present conflict has caused the price of horse shoeing to go up in all parts of the United States and the Lima shoers were thus caused to make a change in the prices.

It is expected that the blacksmiths and wheelwrights of Jacksonville, Florida, and surrounding territory will discuss the matter of raising prices for such work as they perform.

They say the cost of material has increased to such an extent that the raise is unavoidable.

Members of the trade have pointed out that horse shoes which could formerly be purchased at \$3.50 per keg, are now sold for \$5.65 per keg. Horseshoe nails have advanced from 7 cents to 14 cents per pound. Wagon and carriage material has also advanced in price. The increase in prices on the part of blacksmiths and wheelwrights will probably become effective very soon.

Dayton, Ohio, horse shoers will probably raise their prices very soon. During a recent meeting of the Dayton shoers, it was pointed out that horseshoes have advanced in price \$9 per ton since December 18 last, and 44 per cent. since January 1, 1915, while toe calks have advanced 100 per cent. and coal 45 per cent. in the same time. Despite this, no advance in prices has been made by the Dayton horseshoers to their trade.



## Old Man Rut

Farm Imp. News.

Who is it hasn't heart to raise  
His merchandise when more he pays?  
Who fumbles on as in a daze?  
It's Old Man Rut.

Who keeps on selling what's in stock  
Till shelves are bare, then gets a shock  
When once again he must re-stock;  
It's Old Man Rut.

He never knew just what it cost  
To sell his stuff, and so he lost;  
And now his business is storm tossed;  
Is Old Man Rut's.

Collectors knocking at the door,  
And bills are coming due galore;  
He's never seen such times before,  
Has Old Man Rut.

But if he doesn't wake up now,  
His stock soon won't be worth a cow,  
Or just an ordinary sow,  
Will Old Man Rut's.

Some fellows though have seen the light,  
And so are putting up a fight,  
A right to live—their honest right,  
But not Old Rut.

He falters when the strong would speak;  
He dares not ask, when others seek  
A living price—he is so weak,  
Is Old Man Rut.



## Heats, Sparks, Welds

..If at first you don't succeed—consult  
The American Blacksmith.

A smith may win trade without trying,  
but he can't keep it that way.

Every time a man scores a failure, he  
realizes just how little he amounts to.

It takes an all-round hustler to make  
both ends meet these days of high cost.

You kill two birds with one stone every  
time you kill time, for character is killed  
too.

Did you say there was no law which  
compelled a man to advertise? How about  
the law of business success?

Quality and satisfaction speak louder  
than the ring of your anvil. Deliver plenty  
of both with every job you turn out.

About the best way to get even with  
a man is to pay what you owe him.  
Tell this to your delinquent customers.

Some men seem to think that because  
they can make the sparks from a piece  
of hot stock fly like a Fourth of July  
celebration, that they are real black-  
smiths.

He is always willing to tell how he did  
it, and he is always anxious to learn how  
others are doing things. We refer to the  
real live smith.

The best is none too good. Cheap ma-  
chines are expensive and more bother than  
they are worth. Consult our advertisers'  
about good goods. The best is always  
cheapest in the end.

There are lots of chaps these days who  
know more about running your business  
than they do their own. When someone  
tries to tell you how to run your business,  
tell him to mind his.

It is by no means necessary, nor is it  
right, to suspect everybody, but remem-  
ber—all the bunco men are not at the  
county fair, and all of them sell gold  
bricks. Some are fake subscription solic-  
itors.

You cannot cut costs by reducing the  
selling price. You must cut costs before  
a selling price is made. Cutting the sell-  
ing price means cutting profit. If you  
think your profits are too big, then cut  
your prices.

The practical shoer can do a great deal  
toward relieving the suffering of the  
horses that enter his shop, and he can do  
this not alone by shoeing them properly,  
but by dropping a hint now and then to  
owners about abuses and ill-treatment.

It's one thing to own a machine, but  
another thing entirely to use it with  
profit. Knowledge is power, alright, but  
what good does it do a man if he keeps  
it to himself and never makes use of it,  
Or if he doesn't know how to use it?

How is your herd? If you haven't  
plenty of pink Buffalo stamps on hand,  
drop us a postal and we'll head a herd  
your way immediately. Keep plenty of  
these little pink squares on hand and use  
them freely.

You enjoy and profit by what others  
write in our columns. Why not tell others  
of your experiences? Your brother read-  
ers will enjoy your items—send some-  
thing of interest to the Editor, and let  
your brother craftsmen know that you  
are a real live smith.

Why not do it now, For just one little,  
lone, dollar you can have The American  
Blacksmith sent to any one you name,  
get six months' credit on your own ac-  
count, and bring the biggest, brightest  
kind of a smile to our face.

"Have you raised your prices yet?"  
seems to be the common greeting of all  
these days with costs as they are, and  
prices for the necessities of life continu-  
ing to advance. It would not seem that  
the blacksmith would need any excuse,  
whatever, for advancing his prices.

Don't persistently stick to "white-hair-  
ed" methods in these "brown-haired"  
days. Which do you use electricity,  
handpower or the gasoline engine? Pow-  
er in the smith shop is no myth. It means  
more business, more profit and work done  
more easily.

A certain number of shoes and nails  
alone won't shoe a horse correctly. A

certain quantity of brains must be mixed  
with the shoes and the nails. It is not  
only the materials we use, but their in-  
telligent use as well that makes a good  
or a poor job,

Don't fail to have a few boxes of sand  
placed at different points of the shop if  
you do automobile repairing. You can  
never tell when a gasoline fire is likely to  
start, and then, two handfuls of sand  
will do more good than a whole barrel  
of water.

Our advertising columns are open to  
readers also, and any of "Our Folks" can  
purchase space just as cheaply as the  
largest manufacturer. Ask how we can  
help you to place your tools or machines  
before the biggest and best family of  
smiths in the world.

The back numbers prevent you from  
becoming a back number. Do you file  
your copies? There is no better craft  
reading, than the pages of a good craft  
paper. Many of our readers file their  
volumes regularly each year. Let the Sub-  
scriber's Service Bureau tell you more  
about binders for back copies.

Wouldn't your business now be on  
"Easy Street", if you had never lost a  
customer once gained? Study hard  
to hold them as long as you stay  
in business. Look them up when they  
stray—get at the bottom of their dis-  
satisfaction and then square it up if pos-  
sible.

Greenville, Pa., is said to be in need  
of a blacksmith. A fine opportunity  
awaits the right man at that point, and  
the right kind of smith will have a shop  
and residence built for him. If you are  
interested, and can fill the requirements,  
address Samuel F. Ankerbrand, Green-  
village, Pa.

If a man doesn't pay his grocer or  
butcher, is there any reason why he should  
pay his blacksmith? Don't extend credit  
in a hap-hazard way. When a man asks  
for credit, ask him where he has been  
trading, then look up his record; ask the  
butcher, grocer and baker about him and  
then be guided accordingly.

No man, no matter how brutal he may  
be, enjoys seeing an animal abused. If you  
make a special point, and we hope you do,  
of treating the animals that come into  
your shop, properly and without abuse,  
why not make a point of it in your ad-  
vertising? It seems as though a customer  
would prefer a shop where his animals  
would get proper treatment and not abuse.

Did you ever think how a little sum  
put aside every week grows to a big sum  
in a short time? The man who waits  
until he gets a sum large enough to save,  
never saves anything. It is the little  
and often that fills the purse. Just try  
a quarter or a dime a week. Put it in  
the bank at interest, and get an actual  
demonstration of the little and often  
maxim.

Did you ever stop to think what a big  
asset the salesman's smile is? Just think  
of the effect a cheerful salesman has on  
you. How willing you are to give him  
your order. Why not apply cheerfulness  
to your business? Be cheerful and smile,  
be big hearted and square, be good natur-  
ed and pleasant. It pays Mr. Man, it  
sounds, hard dollars and cents, and costs  
you—nothing.



# Our Honor Roll

IT'S EASY NOW TO BE AMONG THE LEADERS.

Do you want to place your name among the leaders? It's easy now. If your subscription expires with the February, 1917, number, send in a little five spot (\$7.00 in Canada or 12 1/4 sh. in other countries) and your name will be placed in the February, 1927, class and you won't need to think about your subscription account for years to come. There are only a few subscribers whose subscriptions are paid up to 1927. Put your name in that group. It's easy if your subscription expires this month—February, 1917. If it doesn't expire this month, ask the Subscription Department when it does expire and how you can get into the leaders' class.

### A NEW NAME IN FIRST PLACE?

The Fix-It Shop has held first place for some months, but we understand some one is planning to take the lead. A twenty-year order will clinch the lead for some one. Who will it be? Watch out for a new name in first place. Something's going to happen soon. Keep your eye on this Roll of Honor.

U. S. and Mexico Canada Other Countries.  
2 yrs. ....\$1.60 save \$.40 .....\$2.00 save \$.50 .....10 sh. save 2 sh.  
3 yrs. ....2.00 save 1.00 .....2.70 save 1.05 .....14 sh. save 4 sh.  
4 yrs. ....2.50 save 1.50 .....3.20 save 1.80 .....18 sh. save 6 sh.  
5 yrs. ....3.00 save 2.00 .....3.75 save 2.50 .....1 £ save 10 sh.  
10 yrs. ....5.00 save 5.00 .....7.00 save 5.50 .....1 £ 14 sh. save 1 £ 6 sh.  
Send your order and remittance now—today. Don't wait until you forget all about it. You'll never regret it. Our subscription insurance saves you money. The sooner you begin saving, the more you save. There is no better time than NOW.

Table with columns: NAME, Subscription Paid to, and a list of subscribers with their respective dates and amounts.

Table with columns: NAME, Subscription Paid to, and a list of subscribers with their respective dates and amounts.

Table with columns: NAME, Subscription Paid to, and a list of subscribers with their respective dates and amounts.





### The Cutting Properties, of High Speed Steel on Cast Iron

JOHN JERNBERG

Instructor Worcester Polytechnic Institute

The heat treatment of high speed steel is today receiving thorough investigation in all well organized shops. Scientific management requires that the manufacturer know exactly what his tools will stand in any phase of his work. Proper heat treatment will produce a tool that will give several times the service of a tool that has not been properly heat treated.

The tests recently completed in the trials described in the following article were of two brands of steel heat-treated by two entirely different methods.

The two brands of steel treated were high speed steel. For purpose of identification, the bars were stamped No. 1 and No. 2. The tools made from these bars were also marked with the number of the bar from which they were made.

Two methods of heating were used in making these tests. The first was by means of a blacksmith's forge; and the second by preheating and then plunging the tool in molten barium chloride that had been raised to the desired temperature. This barium chloride was contained in a 6 inch graphite crucible, and heated in the forge. The temperatures of this bath were taken by means of a Bristol Pryometer, that was carefully calibrated by the aid of fusible salts.

Two cooling mediums were used for hardening the tools. The oil bath used was a mixture of machine oil and kerosene in the ratio of one to one. The salt method of cooling the tool consisted in placing the

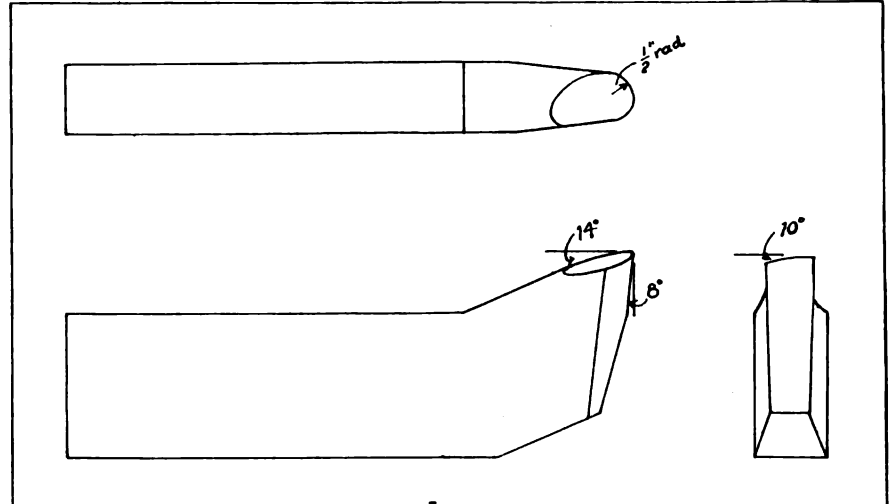

FIG. 1. THE TOOL TAKEN WAS A STANDARD CUTTING TOOL

nose of the tool into a box full of common salt, covering it with the salt, and leaving it there until it was cool.

The first problem was to determine the critical temperature of each brand of the steel to be tested. From each bar, six test pieces were made, each two inches long, one-half inch square, and having a transverse nick at the center. Starting at a point known to be below the critical temperature, these were heated in the barium chloride, one

by one, at one hundred degree intervals and plunged in oil, until a point above the critical temperature had been reached. After cleaning, the pieces were broken and an examination made of the grain. The temperature that gave the finest grain was an indication of the critical temperature.

From Taylor's book "The Art of Cutting Metals", a standard tool form was chosen for the cutting tests. The form of the tool used is shown in figure 1 of the engravings.

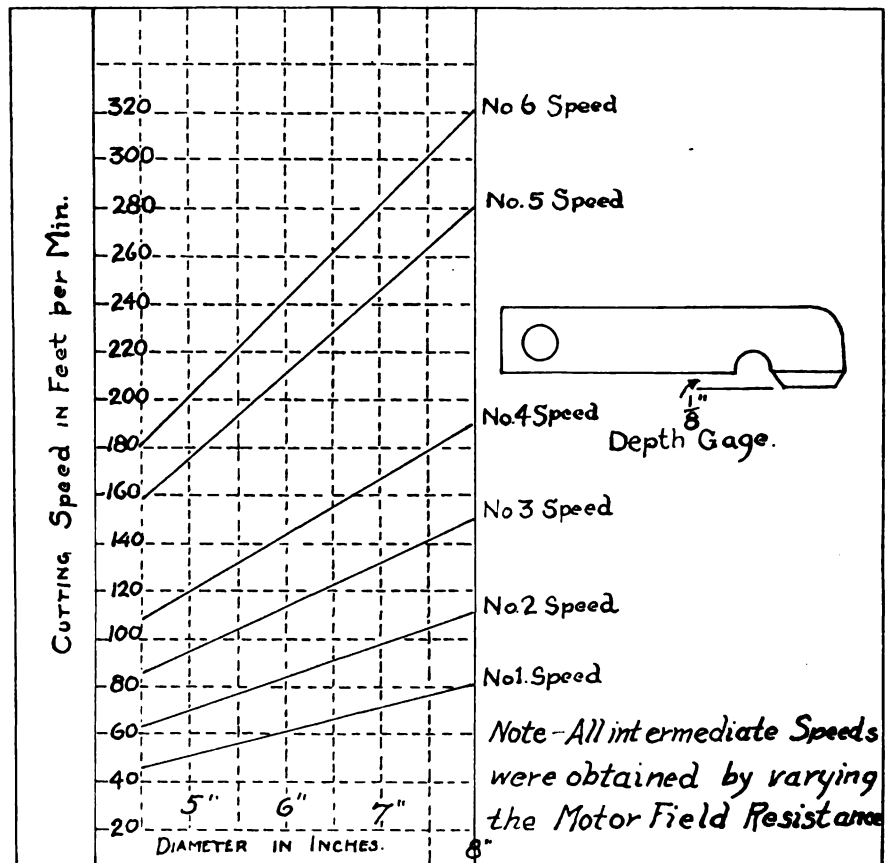

FIG. 2.—THE DEPTH OF CUT WAS DETERMINED BY THE DEPTH GAUGE



This shape is known as the "Standard Cast Iron Roughing Tool", and proved very satisfactory for our work. The shape of this tool was kept standard by means of a tool grinding fixture made by the experimentors. Sketches of these fixtures are shown in figures 3 and 4. These fixtures were a great aid in keeping the tool shape standard throughout the tests. After each test the tool was carefully dressed, and ground to standard shape, the heat treatment performed, and with a little more grinding made ready for the next cutting test.

The test logs used in these tests were made up of soft gray iron from the Worcester Polytechnic Institute Foundry. They were in the form of a hollow cylinder, three feet long, eight inches outside diameter and four inches inside diameter. The hollow cylinder form was chosen, not only because it was more economical of iron, but also because the cooling in the mould would take place both from the outside and from the inside, thus producing a more uniform iron. In every case the hard scale was removed before the tests were made.

The cutting tests were made at the works of the Standard Plunger Elevator Company, on a 16 inch F. E. Reed lathe, driven by an 8 horse power Bullock variable speed motor. The test piece was gripped in a four jawed chuck at one end, and supported on a pipe center at the other end. The depth of cut in each case was 1-8 inch in the radius, with a 1-16 inch feed. This combination was chosen because it is the common cut and feed used commercially on cast iron with a tool of this size. Gauging the depth of cut was facilitated by the use of the depth gauge shown in Fig. 2.

In every case, the tool was kept in the same horizontal plane, and raised to the same relative position on the test log. The tool was given a preliminary run to warm it up, and to see that the tool was cutting properly. All precautions were taken to assure the exclusion of every variable except the heat treatment.

As stated in the preceding, the lathe used was of the variable speed type, having six different speeds, not counting the back gear speeds. Fig. 2 shows the relation between these speeds and the diameter of the test log. It was found in the preliminary runs that the available speeds varied too widely to permit a conclusive test. Hence a variable

resistance was placed in series with the shunt field winding, and we were then able to obtain any desired cutting speed.

The cutting speed was taken by means, of a Warner Cut Meter which is a speedometer, rotated by wheel contact with the surface being cut, and calibrated to read in feet per minute. The accuracy of

nal wheel was fitted to the instrument. The accuracy of this was also checked and found to be within two percent. This new wheel, however, necessitated multiplying the dial reading by two to get the correct cutting speed.

The test to failure was made as follows, after the preliminary run: Starting at a cutting speed of

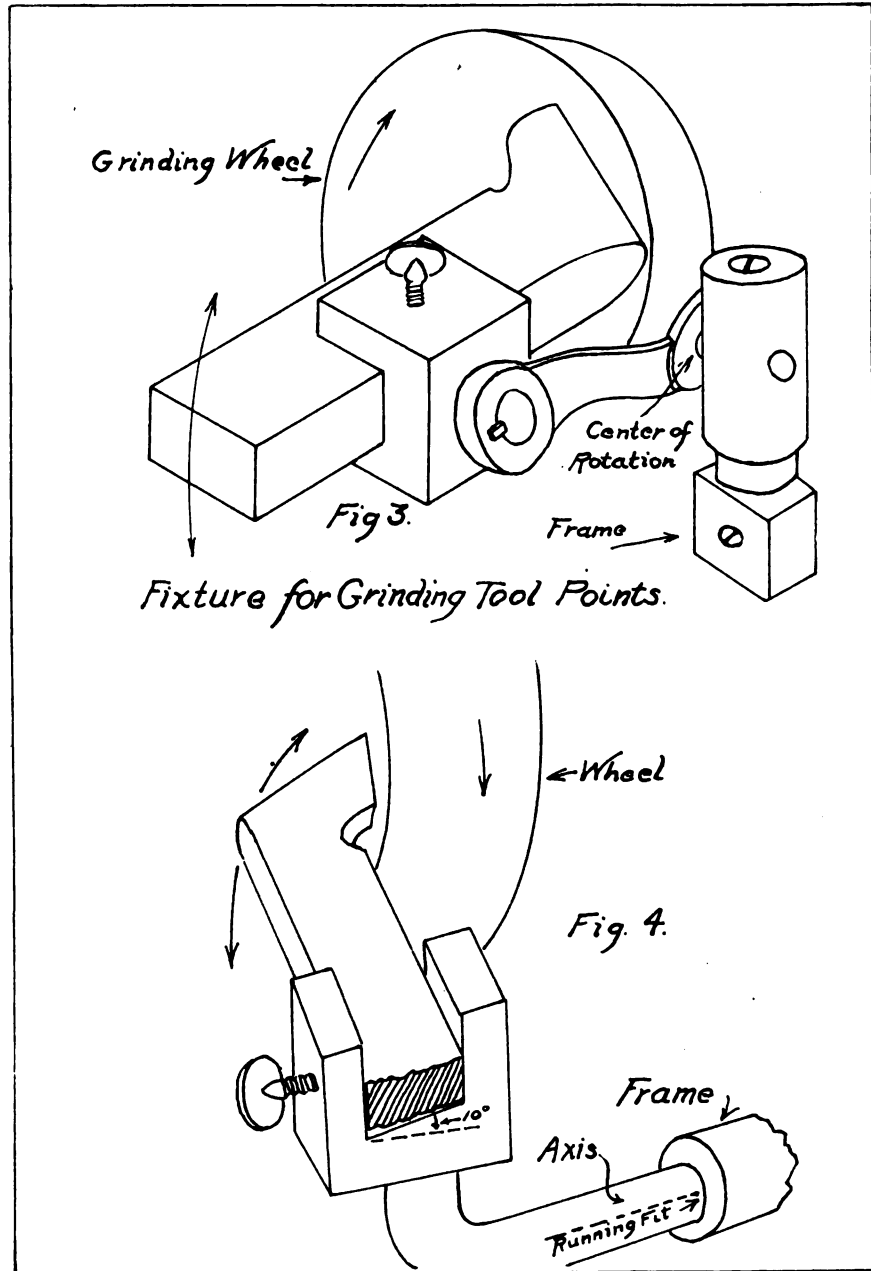

FIGS. 3 AND 4 SHOWING THE TOOL GRINDING FIXTURES FOR KEEPING THE TOOL STANDARD SHAPE

this meter was checked several times by the experimentors, by means of a revolution counter and a stop watch. The error was found to be within one percent. As the tests proceeded, the cutting speed increased beyond the capacity of the meter, and a wooden wheel having twice the diameter of the origi-

nal wheel was fitted to the instrument. The accuracy of this was also checked and found to be within two percent. This new wheel, however, necessitated multiplying the dial reading by two to get the correct cutting speed. The test to failure was made as follows, after the preliminary run: Starting at a cutting speed of



the metal left the tool. The cutting speed at failure as given by the meter was recorded, and in case of any doubt the face of the tool was re-ground, and a check run made. Inasmuch as three tools were used of each brand, the average of the three was considered a fair indication of the value of the treatment in question. The duration of each test was planned to last between four and five minutes.

As stated, these tests were made on two brands of steel. Two bars were received; one, the short bar, being marked No. 1, and the other, the long bar, being marked No. 2. The experimenters were not informed as to the analysis or trade names of either of these bars. The following tabulation shows the method of marking the individual tools made from these bars, and these marks will be used to designate the tools throughout the remainder of the tests:

No. 1—The Short Bar—Tools No. 11, 12, and 13.

No. 2—The Long Bar—Tools No. 21, 22 and 23.

In determining the critical temperature, the test pieces were heated to the predetermined temperature in molten Barium-Chloride. The cooling was done in the oil bath. A Bristol Pyrometer was used to measure the temperature.

Table No. 1.

Test Piece Number	Bar Number	Temperature Degrees Fahrenheit	Grain on Fracture	Remarks
1	1	1900	Stringy	Low *
2	1	1950	Fine	••••
3	1	2000	Granular	••••
4	1	2100	Fine	••••
5	1	2380	Coarse	High
1	2	1950	Stringy	Low
2	2	2000	Fine	••••
3	2	2100	Coarse	••••
4	2	2200	Fine	••••
5	2	2300	Coarse	High

At the point marked thus (\*), a critical temperature was indicated.

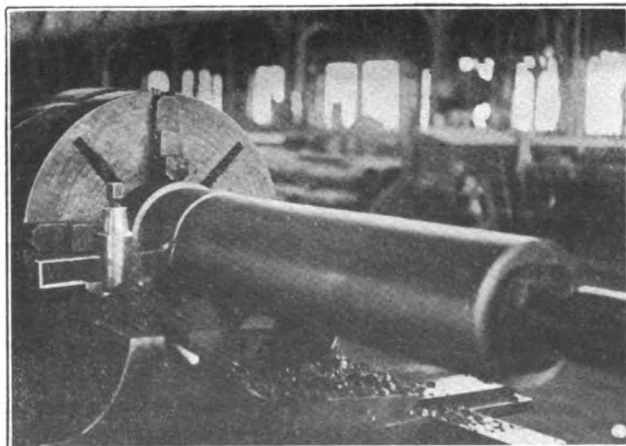

TEST LOG IN LATHE AND TOOL IN CUTTING POSITION

The following tabulation gives the Heat Treatments that were applied to the tools before making the cutting tests as shown by Table No. 3. Hereafter all treatments will be referred to Table 2, by the index letter of the treatment.

Table 2.

Index Letter	Heating Medium	Temperature Degrees Fahrenheit	Cooling Medium
A	Forge	Fusion*	Oil
B	Barium-Chloride	1900	Oil
C	Barium-Chloride	2000	Oil
D	Barium-Chloride	2100	Oil
E	Barium-Chloride	2200	Oil
F	Forge	1900	Salt
G	Forge	2000	Salt
H	Forge	2100	Salt

\*In case of treatment A, the steel was treated in the method prescribed by many steel manufacturers for hardening high speed steel. This was done to give a standard by which the value of the following treatments might be judged.

#### Test Data

Test log—Cast Iron Depth of cut— $\frac{1}{8}$  inch. Feed— $\frac{1}{16}$  inch.

Cutting speed measured by a Warner Cut-meter.

#### Method of Test

The cutting speed was gradually increased until the tool failed.

The cutting speed at failure was tabulated.

#### Analysis of Results.

After the data as shown by Table 3 had been obtained by the cutting tests, the average point of failure of the three tools for each test was calculated. This average was not in every case the arithmetical average of the three speeds at failure, but the balanced average. For example, if in any given heat treatment two of the tools failed at 250 feet per minute, and the third failed at 200 feet per minute, due to a hard spot or blow hole in the test log, the third reading was neglected. Taylor, in his book, "The Art of Cutting Metal" uses this method of getting averages, and the experimenters considered it a fair method to follow.

Using the above principle, the analysis or results as shown by Table 4 were calculated. In order to compare these results, and to obtain a more simple method of drawing a conclusion, 4 were plotted graphically as shown on Curve Sheets No. 1 and No. 2. Curve No. 1 refers to the

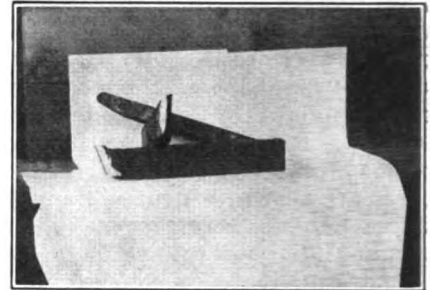

THE STANDARD TOOLS USED

short bar, and curve No. 2 to the long bar.

These curves show the relation between the temperature of the tool on plunging into the cooling medium and the cutting speed at failure.

Curve (A) is considered the standard line, and represents the speed at failure obtained by heating the tool in a forge to fusion temperature, and plunging it in oil. This cutting speed was taken as standard because the method of treatment in that case is the one commonly used in commercial practice.

Curve B shows the relation between plunging temperature and failing speed when the tool has been heated to the plunging temperature in the barium-chloride bath and cooled in the oil bath.

Curve C shows the same relation when the tool had been heated in the forge fire, and cooled in the salt; following the method described on page 5.

Curve sheet No. 1 shows the action of Bar No. 1, or the short bar to the heat treatments, while curve sheet No. 2 shows the corresponding behavior of Bar No. 2, the long bar.

#### Conclusions

Considering first the effect of the treatment as applied to the Short Bar, or Bar No. 1; and basing our conclusions on the results of the tests as plotted on curve sheet No. 1, the conclusions drawn are:—

(1) There is no advantage in using the Barium Chloride method of heating over that of using the forge fire; inasmuch as the tool be heated to 2200 degrees Fahr. or over. At temperatures below 2200 degrees, the cutting speed is seen to drop off very fast, and hence when oil is used as a method of cooling, the temperature should be at least 2200 degrees Fahrenheit to give the best results.

(2) The salt method of cooling, however, is seen to give a higher cutting speed in every case; but for this method of cooling a very low



plunging temperature is needed. As the plunging temperature increases, the steel becomes more and more brittle, and not suited for cutting cast iron. For Bar No. 1, and the

Table No. 3

Treatment	Tool	Test Log Number	Speed Feet	Remarks
A	11	1	250	
A	12	1	256	Was cutting red hot 15 sec. before failure.
A	13	1	260	Failed at next higher speed.
A	21	1	245	Failed at hard end of bar.
A	22	1	231	Had run at 178 for 5 min. and was hot.
A	23	1	204	
B	11	2	182	
B	11	2	175	
B	13	2	205	Ran O.K. for four min.
B	21	2	170	
B	22	2	170	Cut fine to point of failure then failed suddenly.
B	23	2	218	Cut at 160 feet for 5 minutes. Chip extra heavy.
C	11	2	191	
C	12	2	240	
C	13	2	225	
C	21	2	260	Ran at 230 for 3 min.
C	22	2	250	
C	23	2	234	Failed on a new bar.
D	11	3	200	First cut on new bar.
D	12	3	220	First cut on new bar.
D	13	3	210	First cut on new bar.
D	21	3	200	Second cut.
D	22	3	200	Second cut.
D	23	3	200	Second cut.
E	11	4	210	
E	12	4	270	
E	13	4	290	
E	21	4	280	
E	22	4	290	
E	23	4	250	
F	11	4	340	
F	12	4	350	
F	13	4	320	
F	21	4	330	
F	22	4	400	
F	23	4	370	
G	11	4	280	Took 1/16 chip at 300 O. K.
G	12	4	290	
G	13	4	340	
G	21	4	290	
G	22	4	310	
G	23	4	280	Cracked tool used.
H	11	4	250	
H	12	4	255	
H	13	4	360	New steel cutting edge 2 1/2 min. Cut at 300'
H	21	4	320	
H	22	4	325	
H	23	4	360	New steel cutting edge 3 1/2 min. at 200'; 2 1/2 min. at 250'; 3 min. 10 sec. at 300' failed.

salt method of cooling, a plunging temperature of 1900 degrees is to be recommended.

Turning now to a consideration of the action of the heat treatment on the Long Bar, or Bar No. 2, we conclude from an inspection of curve sheet No. 2, that:—

(1) Inasmuch as the Standard Forge Treatment gives a cutting speed much below that obtained by the barium chloride method shown by curve (B); the fusion temperature is too high for the best results. Therefore, for this steel a plunging temperature from 2000 to 2200 degrees is to be recommended.

(2) For the salt method of cooling, there seems to be two critical temperatures indicated, but the lower temperature of 1900 degrees Fahrenheit gave the best results.

In the case of each brand of steel, the cutting speed when salt cooled, drops off with an increase of plunging temperature. The reverse takes place, up to a certain limit, with the oil method of cooling. The only explanation for this, that the experimenters can offer is as follows:

When the hot tool is plunged into the salt, the salt next to the tool is fused, and in the process of fusion absorbs an amount of heat represented by the heat of fusion of the salt. This now molten salt clings closely to the body of the tool, and offers a perfect medium of conduction for the heat in the tool to escape. The heat is thus drawn not only from the surface of the tool, but also from the interior; and an even hardness is given to the tool point.

On the other hand, when the tool is plunged in oil, a film of gas is immediately made between the tool and the oil. This tends to insulate the tool from the oil, and offers a poor medium for the exchange. The rate of cooling is therefore slower than in the case of the salt method of cooling.

To this increase in cooling rate there comes a corresponding decrease in the critical temperature. Fracture tests made at the higher temperatures always showed a very poor grain. The best results were obtained at the temperatures ranging around 1900 degrees.

The experimenters regret the lack of time to make further investigations into the salt method of cooling. While we realize our experiments were very limited in their scope, they serve to show the advantage of the method of treatment over the oil method of cooling.

The advantages of the salt method might be summed up as follows:

- (1) A very great increase in the cutting speed, and durability of the tool.
- (2) A lowering of the critical temperature.
- (3) Cheapness, and neatness. The salt leaves a fairly clean tool,

and is very inexpensive.

(4) Can easily be kept uniform. Were the experimenters to carry this investigation further, every effort would be made to obtain an electric furnace of the type in which the heating medium is a bath of Barium-Chloride, contained in a

Table No. 4

The following table gives the average point of failure of the tools in each test, and represents the summing up of all the experiments.

Treatment	Temperature Degrees Fahrenheit	Cutting Speed Bar No. 1	Failed at Bar No. 2
A-Forge-Oil	Fusion	255	230
B-BaCl2-Oil	1900	187	186
C-BaCl2-Oil	2000	218	261
D-BaCl2-Oil	2100	220	266
E-BaCl2-Oil	2200	257	266
F-Forge-Salt	1900	336	366
G-Forge-Salt	2000	303	286
H-Forge-Salt	2100	288	335

fire clay crucible. Current is transmitted to the bath by two electrodes. The conductivity of the Barium-Chloride at normal temperatures is very small, while at high temperatures (when in a melted condition) they offer to the electric current a comparative low resistance. When the mixture is sufficiently hot, the bath, therefore, forms an electric conductor, and each part of the bath produces its own heat.

The furnace is started by an auxiliary carbon electrode, and the desired temperature reached by varying the impressed voltage.

A great advantage of the electric furnace is that it is possible to cover a wide range of temperatures with one equipment. The tool can stay in the bath, and does not need to be removed before it has reached the temperature of its surroundings. This is not commonly the case with other methods of heating, and gives an absolute assurance that the desired temperature is reached.

While the type of test log used was very satisfactory, there is much to be said in favor of the test log now used by the Ford Automobile Company. It consists of a large disc, held in a chuck, and rotated at a constant speed in the testing lathe. The tool (of a standard side cutting shape) is started at the center of this disc, and fed towards the outside by means of the automatic cross feed. As the radius increases, the cutting speed increases, until the tool fails. The point of failure serves as an indication of the heat treatment value.

This log offers the advantage of



uniformity, simplicity, and quickness. To our knowledge, a log of this description has never been used, when made of cast iron, but had always been made of a definite composition of steel. There would, however, seem to be no serious difficulties in making a cast iron test log,

logs tended to a more immediate failure of the tool. Any chattering also had the same effect. Tests failing because of any of these must be repeated under standard conditions.

On several occasions, while cutting at a high rate of speed, it was necessary to stop the lathe and start a

seemed to put an overload both on the tool and lathe, when stopping from high cutting speeds.

The following test was made after the completion of the preceding work. The purpose of this test was to make certain that a lower plunging temperature would not be better

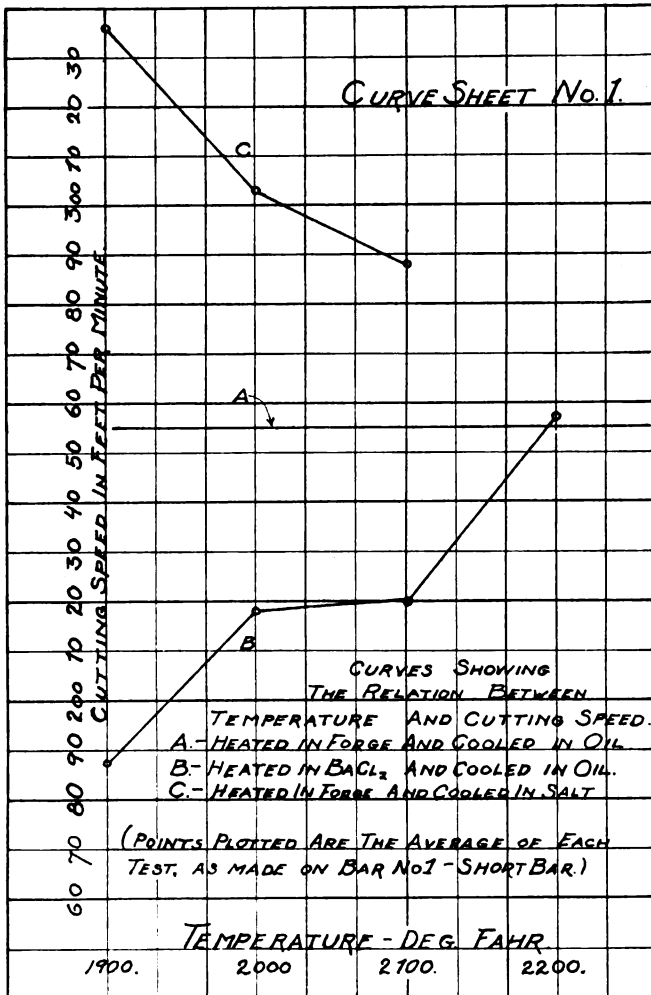

CURVE SHEET NO. 1 WITH NOTATIONS AND REFERENCES FOR BAR NO 1

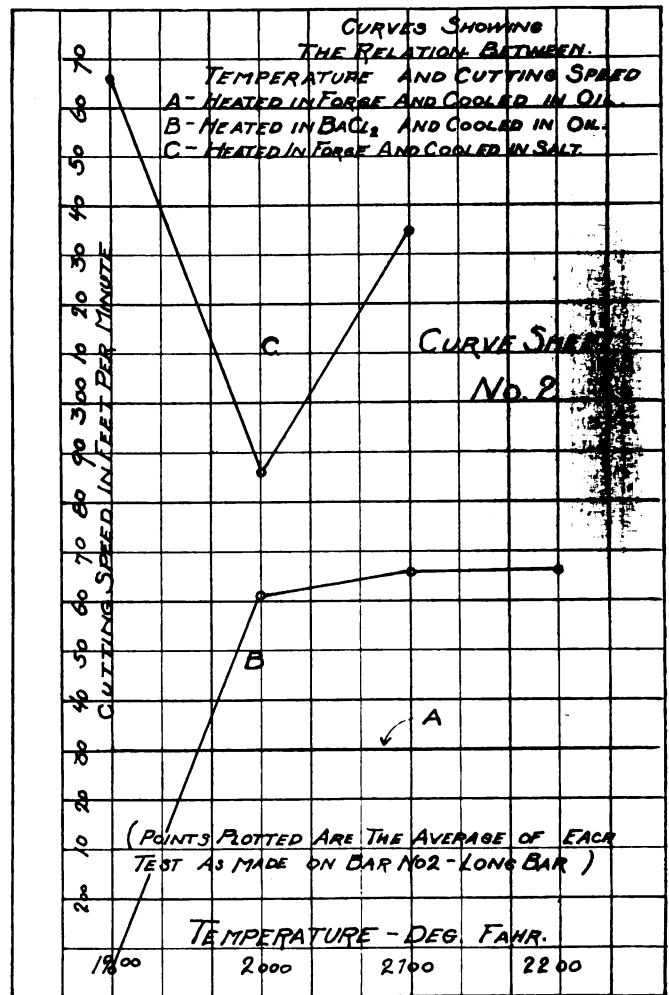

CURVE SHEET NO. 2 SHOWING POINTS PLOTTED FOR TEST OF BAR NO 2

providing due care was taken in moulding and pouring.

In making the cutting test, many points were found that might be well recorded here. It is realized that these facts are well known to the trade, but the investigator must often re-discover these things for himself.

In taking the roughing chip, it was found necessary to drop the roughing speed down as low as forty or fifty feet per minute. At speeds higher than that, the durability of the tool was greatly decreased, and necessitated frequent grindings. The point of the tool should also be at least 1-16 inch under the scale all of the way around.

It was noted that the presence of blow holes, or hard spots in the test

new cut. It was noted that if the tool be left in the cutting position, and the power feed released, the tool failed before the lathe could be stopped. We found the safer method was to gradually back the tool away from the work while rotating, and then stop the lathe. The reason for failure may be explained thus:— When the power feed is thrown off, fresh cool metal ceases to come on to the tool point, and this combined with the fact that the metal rubbing against the point acts as a grindstone, causes the generation of an excess amount of heat, and the tool fails.

It would, of course, be possible to leave the power feed on, and to shut the motor off with the tool in the cutting position. But this

when the salt method of cooling was to be used.

Treatment	Temperature Degrees Fahrenheit	Cutting Speed Bar No. 1	Failed at Bar No. 2
I-Forge-Salt	1800	290	330

The speeds at failure in this case are seen to be lower than those obtained by heating the steel to 1900 degrees.

## Notes on the Theory and Practice of Hardening

T. WEST  
Springs.

Springs are things in the hardening of which the value of baths is particularly manifest. I cannot think of any other



steel article which is so often badly hardened and tempered, when made in an ordinary jobbing shop, by the usual methods in vogue there. A thin, wide spring gets warped, owing to unequal heating in a naked fire, and afterwards is made softer in some places than others, through being tempered over that fire. Although this inequality is not visible to the eye if "blazed off," nor after colour-tempering over the

intended restraining effect, whereas if the wire cools first, it contracts to the original length just before the spring gets cold.

If a heated oil or grease-bath is used for tempering, the result is more certain, and all that is necessary in tempering is to watch the thermometer slowly rise to the degree which previous experience has shown gives the best results. With a molten-tin bath, colour must be depended up-

different minds. As querist speaks of fair quantities, fair apparatus would certainly repay their cost quickly. I do not know the length of spring requiring hardening; but assuming it is not longer than the depth of a large cast-iron saucepan, this would answer for the molten bath in which to heat for quenching. It would not crack if care were exercised in not urging the heat too fast until the lead

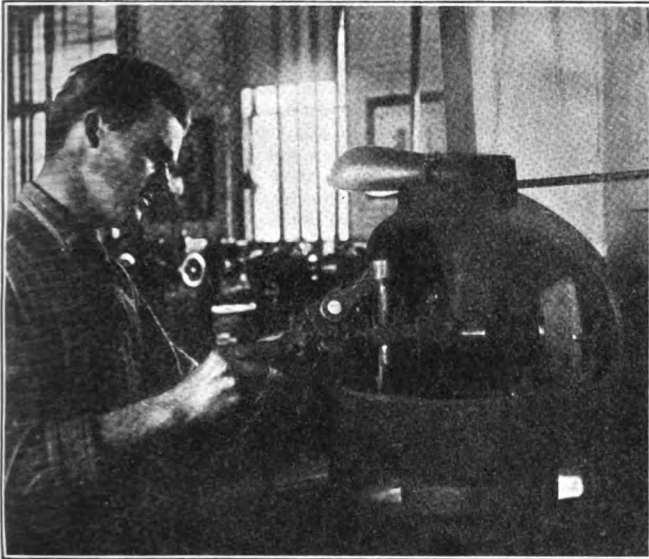

THE GRINDING FIXTURE IN USE

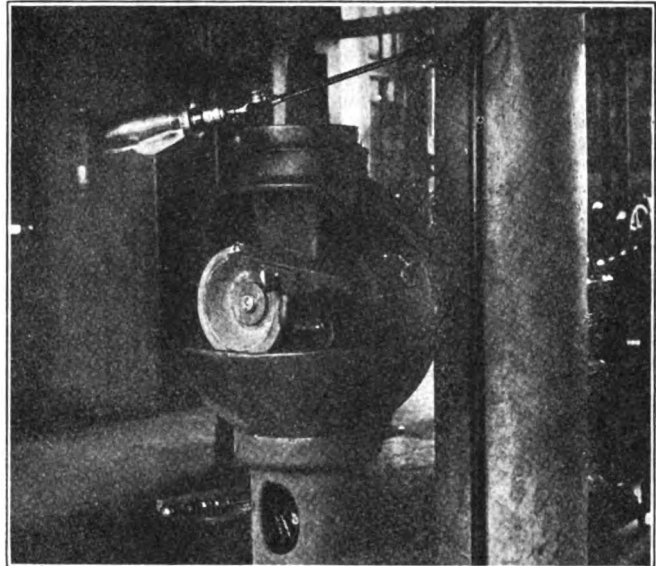

DETAIL OF TOOL GRINDING FIXTURE

fire, when spring has been polished, yet it is there all the same, and it certainly becomes visible later on when in use, for it fractures or gets flabby, according to whether the hardest places are too hard, or the softest places too soft. In the old days of the high bicycle, before there were competent firms making bicycles, I learned this, to my cost. By the skilful use of baths, neither of these faults is possible. A spring, whether of flat or round steel, should be well annealed after being brought to the intended shape, and should be allowed to get quite cold between each annealing. It should then be coated with lampblack and linseed-oil, or the paste before described, and when dry, inserted in the molten bath at a dull red. A similar piece of steel should be inserted with it. The heat of bath and contents should be raised a little, and a test made with the trial piece of steel. As soon as this will harden, the spring should be quickly withdrawn from bath and quenched, dipping it below the surface of the water as rapidly as possible. The manner of dipping depends upon the shape. A curved spring should be dipped perpendicularly, which is the best for any spring, where it is possible, but coiled springs of every kind do not admit of this being done. If they are dipped sideways, they have a tendency to stretch, and if edgewise, to warp. As a rule, I have found it best to dip flat coiled springs edgewise, and wire coiled springs longways, thrusting them beneath the water instantaneously. In hardening a C-shaped spring, that is required to keep its exact form, it is necessary to fasten it in position whilst heating and quenching, by binding it with very thin wire; stout wire should not be used, as it may hold heat where it touches the spring, as well as taking as long to cool in the water, as the spring does, and then the expansion of the wire whilst hot would deprive it of the

on for temper, and in this case a piece of brightened steel of about the same section should be used as a test. Here, too, it is necessary that the bath should have its heat raised slowly, as otherwise the temper heat may be attained, and then be exceeded before the article can be removed from the bath. If the bath is wanted for a succession of articles at one heating, it can be cooled between by putting a cold bar of iron in it between each operation. This, of course, can also be done in the case of the red-hot molten bath.

I have sometimes had it happen that, despite all precautions, a spring needed of exactly the form given, will alter in quenching. The only remedy is to measure how much it has extended, then anneal it, and make it the same distance closer that it extends in hardening. A very contrary spring that I once made, that had to be exact, I had to alter six times before I got it right. In the finish, I am sorry to say, the spring's temper was better than mine.

In spring-making, it is very necessary to have a steel of a grade made for this purpose. A piece of steel that would make an excellent cutting-tool would make a very bad spring. I have made them, when I could not wait, out of drill-wire and blades of hack-saws with the teeth ground off, trusting to my knowledge of hardening and special appliance to compensate for the improper steel; but even if they worked for a time, they were sure to break soon.

I had written the foregoing when a query appeared, asking particularly as to the best methods of hardening spiral springs in quantities, without elaborate apparatus. As an answer to this may be more useful in this series, I propose to make it here. It is not possible to do this efficiently, without special appliances, and what is, or is not, elaborate, varies with

was melted; but if molten salt were used I fear it may, as this requires a red-heat to melt, so that the bottom of saucepan would get red-hot whilst the sides were black-hot, the expansion bulging the bottom and splitting it. As lead melts at a black heat, the convection of the liquid lead would carry the heat to the sides whilst it was attaining a red heat. Town gas, or a very large paraffin blow-lamp would have to be used. An arrangement of firebricks, set in fireclay, to surround the bath must be made, with space between to allow the flames to play on the bath. As the difference in cost between tin and oil or grease that would fill a similar-sized bath would be greater than the price of a thermometer, as well as the oil-bath and thermometer, being much more efficient for this class of hardening, an oil-bath should be preferred. This bath can be charged with beef tallow, which must be made free of all trace of salt. Boilings in two or three waters will extract all trace of salt, and the tallow can be skimmed off the water when cold. Any water left in the tallow will be evaporated when the bath is heated. "Black Tempering Oil" can be used instead of tallow, if preferred, as this does not give off such a cookshop smell as the beef tallow when in use. This oil can be procured through any of the agents of the Standard Oil Company.

The oil tempering bath should be fitted up with firebricks and clay, similarly to the molten lead bath, and for safety it should be well enclosed round the top, with a stovepipe to carry off the fumes from the gas or the blow-lamp. The lid should be kept handy, so as to shut down oil, in case of its accidentally getting overheated and catching fire, and a garden syringe and water are well to have at hand. There is no excessive risk of fire, but even a paraffin stove catches at times.



I had a paraffin stove, that the makers had carefully cast a ridge all round the top, so as to form a nice little well for any oil that might get spilled in filling. I used it for heating a gluepot, and the careful forethought of the makers was rewarded one day by the heat from the burners near the catch-well causing the spilled oil to vaporize, ignite, heat the oil container, and make a good bid to burn down my workshops. But the syringe I always keep handy in a pail of water soon brought the stove to reason, doubtless disappointing its makers of so good an advertisement as a fire caused by this oil-stove would have been.

A high-temperature thermometer will be required. These are made of boro-silicate glass, and are filled with nitrogen at a pressure of 20 atmospheres above the mercury. The pressure is to raise the boiling-point of the mercury, so that higher temperatures may be registered, than the normal boiling-point of mercury, and nitrogen is used because it has no chemical action on Mercury at any temperature. The boro-silicate glass bears variations in temperature without cracking that would certainly break ordinary glass. These thermometers are safe up to 500°C.

An iron frame, the shape of a gridiron, should be made out of thick wire, with the bars of such a distance apart as would be, say, three diameters of the springs, so that when the springs are suspended from the grid there will be sufficient cold water between each spring to insure hardening. After the springs are wound to shape, they should be carefully annealed. A naked fire is likely to "burn" portions, so the molten lead bath can be employed for this purpose also. Heat it to a bright redness, suspend the springs by fine wire from the grid, at a distance of three diameters between each spring, the fine wire being of a length that will allow the springs to be entirely submerged in the molten lead. The springs must be previously covered with lampblack and linseed-oil, or the paste, recipe for which has been previously given. Immerse the springs in the bath, and allow them to remain sufficiently long to attain the bath's temperature of bright red. There is no danger of any "perishing" action on the steel whilst in the bath, even if left there a considerable time, as the oxygen of the air is excluded from contact with the steel. Withdraw the springs from bath, and keep them just out of the lead, the heat radiated from which will retard the cooling, and so assist annealing. When the springs are black, take them away from near bath, and allow them to get quite cold. Again cover them with lampblack, etc., and allow them to get dry. When they are fit, get the bath to a dull-red heat, dip them in the bath, and allow them to remain there. Test the heat of the bath with a similar piece of steel, as before directed, and when it hardens quickly remove grid and immerse the whole in the water. As soon as they are cold, remove them, and dry them over the bath; but be careful not to heat them to a tempering heat. Whilst hardening the springs, the oil-tempering bath should have been heating, and when the thermometer shows the right degree for the temper required for the particular grade of steel used—i. e., percentage of carbon in the steel—the springs must be immersed in the oil-bath. The thermometer will recede a little, but shortly it will regain the tempering degree. Before the bath has time to exceed this degree, the

springs must be withdrawn and cooled in water. To ascertain the right tempering degree of temperature, a reference to the table I have given before will help, and probably an experiment with a single spring would be of advantage; as the best degree, once found, can be adhered to as long as the same grade of steel is used.

Quenching in hot water onwards to boiling-point, varying mixtures of sperm, neat's-foot, and other oils, with an occasional addition of rosin, lard, cow's dung, pitch, and so on, are said by the early writers to produce spring temper at the one operation of quenching; but for these to give uniform results the weight and section of the spring must be small, as well as being the same for each special mixture; otherwise the hardness will vary with the weight and section: the thicker the section the softer the temper, until, with increased section, a point will be reached where there is no spring temper produced. The degree of red-heat, too, at quenching, would also have a large influence, the hotter the steel, the softer the temper, because the more heat there was for the quenching medium to have to remove from the steel, the slower the cooling would be, and as this heat also raised the temperature of the quenching medium near to the steel, this also would retard cooling, during which time the hardening carbon is constantly resolving into carbide, so that the very object of quenching—i. e., stopping this process—is defeated.

These directions may lead querist to suppose that much time will have to be spent in carrying them out; but it must be recognized that as this method permits of a number of springs being hardened together, there will be an actual saving of time on other methods, where only one at a time is hardened. The results will be far superior.

I have read "Chrome's" letter with much pleasure, but fear that I must join issue again, which I propose to do later; otherwise, the querist I am hoping I have helped would have to wait. I wish I could agree; but "Chrome" has overlooked some points in the actions he cites, to which I hope to draw his attention. Meantime, like Cato over Carthage, I am still of the opinion, etc.

—o—

When you are feeling discouraged and blue over your prospects—and things look dark sometimes even to the members of the best trade on earth—think of the progress which the craft has made in the past few years. Think of the improvement made in the shops and their equipment; think of the better machines; the better tools and the better ways of doing work; think of the progress the smith himself has made in his business methods; think of the advantages which you enjoy and which your father and grandfather knew nothing about. Your thoughts along the above lines, cannot help but make you feel proud of the craft, proud that you are a member of it, and proud of your part in making up its history.

To get real value out of a bucket of paint as a user, you must use it. Ten barrels of paint standing in the cellar, won't do your roof any good. To get real value out of it you must use it—apply it. Ten times as many pages in THE AMERICAN BLACKSMITH each month, won't do you any good unless you use them—unless you

apply the ideas—the hints, the kinks, the recipes, the formulas, the methods.

To get real value out of a page of THE AMERICAN BLACKSMITH, you must apply that page to your work. If you don't do that the papers are not worth the postage spent in carrying them to you. Apply "Our Journal" to your work. That's how "Our Folks" get five, ten and twenty-five times its cost out of the paper.

You cannot make more profit by cutting anything except expenses or costs. Cutting prices never produce satisfactory profits because the cut is at the wrong end of the business transaction. If you feel that your end of the selling price is too big, that you are imposing upon your good customers, that you are making too much money, then cut your prices to wherever you think they should be. But, if you consider the present cost of stock and supplies high enough and your profits too small, cut down expenses, boost your prices and get the reward that you should really have for your labor.

Is your dollar worth one hundred cents? Yes—Uncle Sam has stamped it so, but is it full weight when it works for you? If you are working that dollar equally hard at both the buying and the selling end, you are getting full weight, but if you are working it hard only at one end, you are not getting one hundred cents' worth. You sell your work to get dollars—you sell the dollars to get supplies. If you sell one hundred and ten cents worth of work to get one dollar and then sell that dollar for ninety cents' worth of supplies, how long can you stay in business? It is not so much the dollar that determines your success in business, but what you get and give for the dollar. To get and give really determines the work of the dollar. Are your dollars worth one hundred cents?

## John L. Sullivan and the Village Blacksmith

W. J. MCCORMICK

Smiling congenially, the same old John L. Sullivan was in Peoria recently appearing at the Orpheum theater, both afternoon and evening. The former heavyweight champion pugilist of the world appeared in a four round exhibition with T. Chandler, former middle-weight champion and the pair are drawing a capacity audience at every show.

Sullivan when not appearing on the stage falls back on anecdotes.

Reminiscence and stories of his old time battles; he came to Peoria from Davenport, and related a story of a little encounter he once had in that city. It is a story of the Davenport Blacksmith and here it is: It was back in the days when Sullivan was touring the country and knocking out all comers in four rounds or forfeiting \$1,000 to any one who lasted this limit, "and by the way I was the only fighter that ever did that" commented John L. Sullivan. Blacksmith, Tom Sheehan was an exceptionally strong man. He



could lift an anvil by its horn" said Sullivan. Sheehan was so powerful that his wife begged him not to go to the theater the night of the exhibition, and previously Sheehan consulted a lawyer to see if he could be held in case he should accidentally kill the champion. But let John L. finish the yarn which has been told on Cork Hill Davenport, to the writer's personal knowledge, for years back on account of the fact that Sheehan came from Rogerstown, a district with which Cork Hill was never on any too friendly terms. "I sized up the big Irish terrier as he stepped in to the ring", said Sullivan, "I knew he knew nothing about boxing, so I landed him one in the pit of his stomach and up and swatted him on the jaw with my other fist and down he went on the flat of his back."

These strong Blacksmith articles are interesting to every anvil ringer. I have shown them to friends and told them about this feature.

Here is another strong blacksmith I personally knew. A. L. Pittinger, several years ago, a Canton champion wrestler and star member of the tug of war team of the P. & O. factory is now one of Smithfield's blacksmiths. He has a good shop and is prosperous. Mr. Pittinger is wrestling with no terrible Turks or Russian Giants. (These were some professionals he met.) In these days he is tackling nothing worse than vicious mules and nervous horses, and he's winning every fall.

### A Handy Chart for Finding the Volume of Tanks

W. F. SCHAPHORST

The chart on this page will be found very useful by any one for determining the volume of cylindrical tanks without doing any figuring. All that is necessary is to know the diameter of the tank in feet and its height in feet. Knowing these two dimensions, we take a straight edge and lay it on column A corresponding to the diameter in feet and on column B corresponding to the height in feet. The point at which the straight edge crosses the line B and C will tell you, in the B column the cubic contents of the tank in feet and in the C column the number of gallons it will contain.

For example:—How many gallons will a tank hold whose diameter

is ten feet and whose height is twenty feet?

We connect the ten in column A with the twenty in Column B and find the answer in column C is about 11,700 gallons, which is very close to the correct answer. In this same problem, column B shows us that the cubic contents of the tank is practically 1550 cubic feet. The exact answer is 1570 cubic feet which answer is gotten by means of figuring. The chart, however, is fairly accurate, although not absolutely so. Most graphic charts of this type possess a certain degree of inaccuracy, but they are useful because of their simplicity, and are very satisfactory for the average calculation.

This chart may also be used in a reverse manner or to give the dimensions of a tank to contain a certain number of gallons or a certain number of cubic feet. For example: Suppose we want a tank holding 100 gallons. Reference to our chart shows that a tank two feet in diameter by four and one half in height, will contain the required volume. On the other hand we also find that a tank three feet in diameter and two feet in height will contain the same volume. Thus we can build our tank to various measurements and choose those measurements which prove the most economical, or best suited to fit individual conditions. Through trials and tests of various examples in calcu-

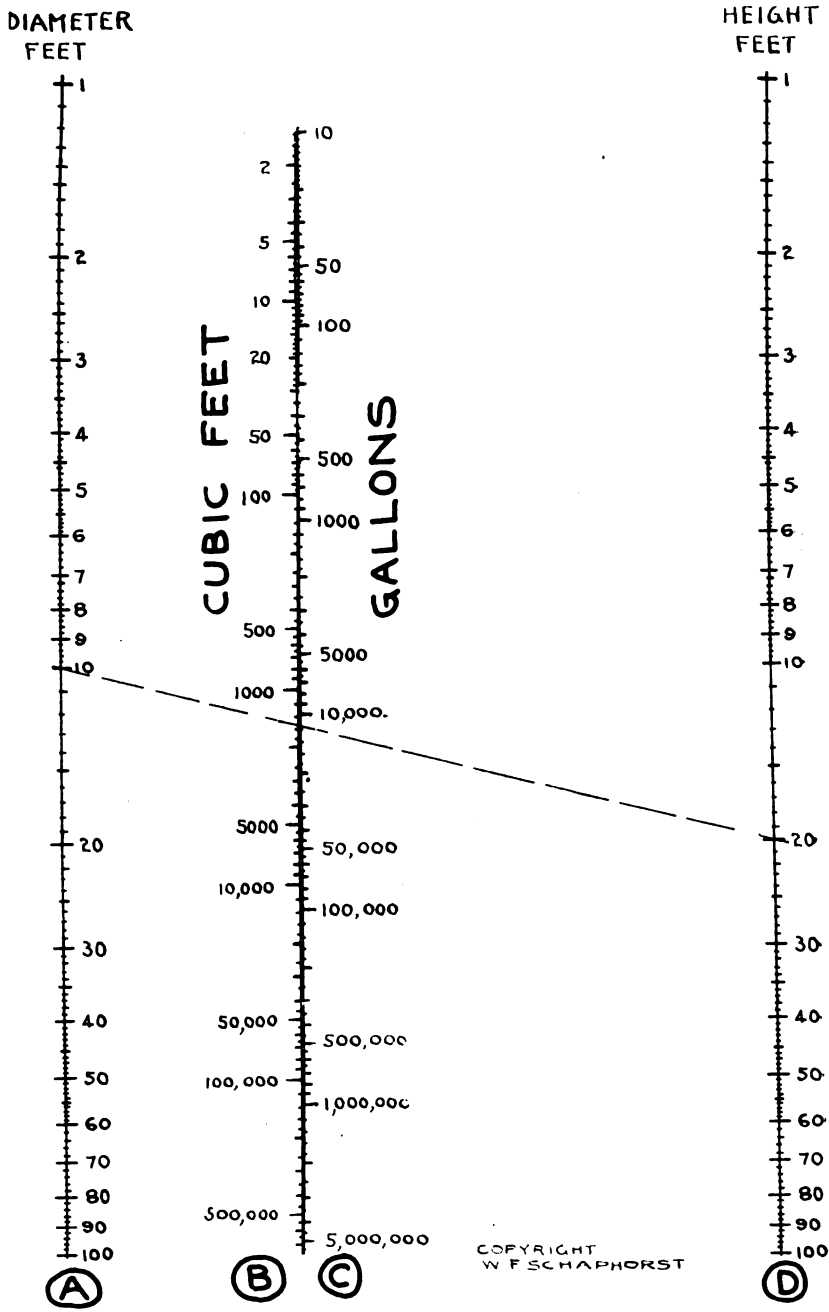

A SIMPLIFIED CHART FOR FINDING VOLUME OF TANK

COPYRIGHT W. F. SCHAPHORST





lating the dimensions and volumes by means of this chart, will soon make the reader expert in its use.

## Gas Engine Bearings

J. L. HOBBS

Where the bearing is to be put in in two pieces, take off the top half of the bearing and lay it aside. Apply the coating of soap to the shaft, stop off the end of the boxing with mud and pour in the babbit until it comes up almost half way on the shaft. After the babbit has cooled, dress it off smoothly and lay on two or three thicknesses of card board, which fit up snugly against the shaft, place the top half of the bearing in position and stop the end of it with mud and you are ready to pour the top half of the bearing. After this has cooled take it off and bore out the oil hole with a drill of some kind, place it back in position and it is ready to run. You may have to place a couple of thin sheets of paper between the bearings on top of the card board to make it loose enough to allow the nuts to be screwed down tight, but this can be determined by testing. This is all that is necessary to know to run babbit bearings.

Bronze and brass bearings require quite a little more skill to handle, as the metal has to be so much hotter, and also where a bronze bearing is used the fit must be so much more exact. A bearing, to give the best satisfaction, should run just as tight as it will run without heating. If allowed the least bit of play it will wear much faster, and is apt to wear out of round and spoil the shaft.

The main parts of an engine, besides the bearings are, the cylinder, piston, rings, valves, igniter, mixer, exhaust, muffler, crank axle, fly wheels, frame, cam shaft, etc., all of which will be taken up and their part in the working of the engine explained.



## Benton's Recipe Book

When working steel, a good slogan to adopt for your guidance is: "Don't hurry."

For edge tools; heat slowly and do not heat too hot. When you draw the tool out, do all you can at one heat, and finish with a wet hammer and anvil until almost cold. To temper, lay a piece of steel on top of slow fire and heat very evenly before you temper.

When drilling or filing hard castings or hard iron, use turpentine on the drill or file. It will surprise you how quickly and easily your file or drill will work.

A blackboard paint is asked for by C. W. N. Here is what the recipe book has to say on the subject: Take and mix four pints of alcohol, eight ounces of shellac, twelve drams of lampblack, twenty drams of ultra-marine blue, four ounces of powdered rodden stone and six ounces of pumacestone. First powder and dissolve the shellac in the alcohol, then add the other ingredients, finely powdered, and shake well. Too apply the slating, have the board smooth, and perfectly free from grease. Pour out a small quantity into an old tin can and apply it with a new flat varnish brush as rapidly as possible. Instead of alcohol, a solution of borax in water can also be used. Dissolve the shellac in this and color with lampblack. Dilute silicate soda or water glass, with an equal bulk of water, and add sufficient lampblack to color it. The lampblack should be ground with water and a little of the silicate before being added to the rest of the liquid.

A cement that will stand both water and heat can be made as follows, by W. C. B: Take freshly calcined oyster-shell lime, sift well and grind finely, make into a paste with white of egg, apply to the fracture and press the broken pieces firmly together and allow to set.

An excellent mixture for woodworking frictions is made by mixing four parts, by weight, of tallow or soap with one part of finely ground plumbago. This is an excellent lubricator for woodworking on wood, and it is fine for wood screws or threads.

The tempering composition used by saw-makers (in reply to G. C. W.) for tempering saw-blades and which is applicable to other articles of a like nature, is a mixture of two pounds of suet, one-quarter pound of beeswax and one gallon of whale oil. oil all of these ingredients together. The addition of one pound of black rosin to a gallon of the mixture makes it serve for the thickest blades or pieces. The rosin should be added with judgment or the work will become too hard and brittle. After being used for a couple of weeks the composition becomes useless.

To remove rust from a finely polished steel surface without scratching it: Take eight parts of tin putty, ten parts of the prepared buckshorn and 250 parts of spirits of wine. Mix to a soft paste and rub on the surface with a woolen rag until the rust disappears, then polish with a dry soft cloth.

A suggestion that will perhaps interest a number of blacksmiths is a method for fire proofing wood. Take three parts of alum, one part of copperas, and dissolve in water. Apply the mixture hot to the wood and repeat until the wood is well saturated. Then follow with a solution of copperas, mixed with fine clay to the consistency of paint. Apply with a brush. Another mixture is one made up of three parts of ground wood ashes and one quart of boiled linseed oil. This mixture is also applied with a brush.



## Queries—Answers—Notes

Has a forging horse:—I would like some brother to tell me how to stop a horse from forging. I have tried about everything that I know but have failed to stop her entirely. She is a very short bodied horse. Any information on this will be appreciated.

A KENTUCY SMITH.

Wants to know about Drop Forging—Will write a few lines of inquiry on drop forging. I would like to see more articles on drop forging in "Our Magazine". I want to get posted on that branch, because I think there is a good opening in Seattle for heavy and drop forging.

There are 4 new ship yards built and building here in the last year, and there are three of them that are not going to do their heaviest forging that I know. I am working for one of them.

I. N. BOWEN, Washington.

Taking up auto work—Please find a renewal of my subscription for three years. Your auto stunts are all right. Give us a lot of it, as I am beginning to take in that line of work.

CLARENCE WOOD, Ontario.

A Blacksmith Devises an Entirely New Tool

In announcing "an entirely new tool" C. H. Handerson, Editor of "Drill Chips" the chipper little magazine published by the Cleveland Twist Drill Company tells the following tale with his characteristic twist.

We Announce an Entirely New Tool

Under a spreading chestnut tree out in Salina, Kansas, there was once a blacksmith. History records that he was a good blacksmith and did a rushing business. Everything ran smoothly, with one single exception—about every so often, a set-screw or stud, with an ingrowing disposition, snapped off, and stole two or three hours of his productive time before the broken section could be recovered.

But with this single irritation the years rolled on—as only years know how to roll—until the gasoline buggy began to amuse itself by puncturing holes in the blacksmithing industry of Salina. Day by day the gladsome clang of the hammer became fainter and fainter, while the thud of exploding gasoline became steadily more noticeable.

Our friend—being a man of foresight—saw the writing on the wall, and slipped off his leather apron, to appear in grease and goggles as a full-fledged garage and repair man. In time he became one of the town's foremost exponents of the gasoline



route and conducted a thriving business as an all-around machinist.

But his troubles were far from past, for always the broken set-screw dogged his footsteps. Indeed, in his new field it dogged him with even greater persistence than before. For a time, he—like every other machinist since the time of Noah—fussed around with the time-honored three-cornered file or punch and such other makeshift tools as he had at hand—and he had plenty. But in spite of all his skill, that sudden, vicious snap of a breaking screw continued to mean from one to three hours of the nastiest sort of exasperating labor.

Finally it happened once too often—the camel's back was broken—and the hero of this tale set himself down in a cool corner to devise a tool that would remove broken screws without likewise removing two or three hours from the face of the clock and a large share of a fellow's chances for the Pearly Gates of the Hereafter. Gradually this tool took form. In its early stages it looked very much like a twist drill on a spree. Sometimes it worked and again—it didn't. He knew he had the right idea but it had a "bug" in it somewhere. So he took the train for Cleveland and turned it over to us for development.

A little practical suggestion here and a little more there took out the kinks and polished off the crudities. Gradually it became more practical and sure of operation. All that was three years ago.

Today this tool represents the results of three years' experimentation and test, and now it stands a proven success—ready to serve you as the only tool ever designed for the express purpose of removing broken screws of all kinds—set-screws, cap-screws, studs, stay-bolts, etc. This new tool is called The Ezy-out Screw Extractor.

#### A Defense of the Craft

The following verses are from a local paper which reprinted the matter from the New York Times:

**The Village Munitions Co. (Inc.)**  
Formerly The Village Blacksmith  
(F. P. A., in *New York Times*)

Under a spreading chestnut tree  
The smithy used to stand;  
The smith, a prosperous man is he  
As any in the land;  
For many a shell in a foreign trench  
Now bears the smithy's brand.

His clothes are new and fashioned well;  
His foods are rich and rare;  
His hands are nicely manicured,  
And freshly trimmed his hair.  
And he slaps the whole world in the face,  
For he is a millionaire.

Week in, week out, from morn till night,  
And eke from night till day,  
You can see his factory fires aglow—  
(Three shifts at double pay).  
None makes more profit than the smith  
In all these U. S. A.

And people coming home from work  
Look in at the open door,  
And say, what time they see the fires,  
And hear the bellows roar;  
"I wished I'd bought some Blacksmith  
common  
When it was 24."

Toiling—rejoicing—profiting—

With pleasure evident,  
Each morning sees some shells begun  
For some belligerent.  
Something attempted—some one done  
Has earned two thou. per cent.

Now, I am in a quandary to know just how to take, or understand what this

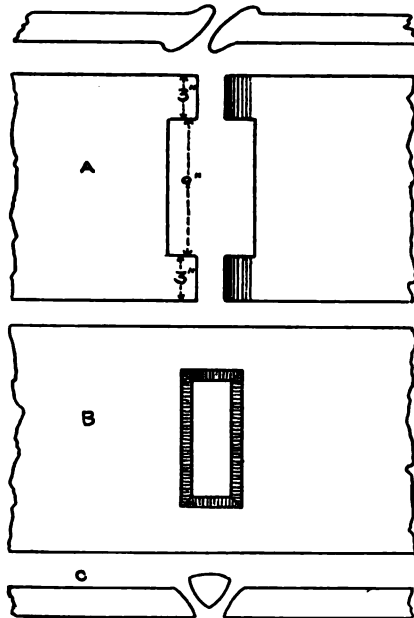

HOW WIDE STOCK MAY BE WELDED

means, or what the author had in mind when he or she hatched it. For I think it really is a hatchery, or a pipe dream. The way I look at it, this is an insinuation upon the good name of the *Craft*, or either the writer is "War Crazy," and thought that the whole world was in eruption and that us poor common blacksmiths were drawn to the last thread, and had nothing left to do but to turn as a last resort, and engage with others in assisting the Old World in destroying one another.

Now, I rise as a member of the good old trade, that has given to myself and family an honest and upright living for these very many years, and in defense of the good and honored name of Longfellow, to denounce the imposition that is conveyed in this poem. I wish to say that while I boastfully claim membership in the fraternity of which I speak, I deny that I have made or assisted in making any of those death dealing missiles or received any of the fabulous returns of profit now marked by that "three shifts a day."

And if the war was to last forever, God forbid my assistance. And please inform the world that this "Blacksmith Shop" still stands "under" that same proverbial "chestnut tree."

Hoping all will grasp the meaning of this, and again denying any connection with this Poetic Blacksmith, I am, with best wishes for the future of the grand old craft that is not engaged or accused.

H. E. KERNEK, Missouri.

**Welding Wide Stock**—I have some bands to take from stock, fifteen inches wide. How can I weld this stock in the ordinary fire? Can you help me out?

L. J. THOMAS, Ohio.

**In Reply**—Difficulty would, of course, be experienced in attempting to weld this

width of stock in the ordinary fire in the regular way. However, this work can be done very easily by preparing the ends to be welded as per the engraving at A. The projections, measuring three inches in width at each side of the stock, are scarfed in the regular way as shown and then welded—one side at a time. When welded the piece will have a slot measuring nine inches in length. The edges of this slot are now sloped V-shape with the fuller, as shown at and at C, in the sectional view. Now, a V-shaped piece is forged to fit into the slot with material enough for welding. The wide piece is now heated up and the slot filled up at one end first. Weld only as much as you can easily with one heat. Don't force your weld and take another heat when necessary until the entire length of the V-shaped piece is in place. In heating that portion of the stock around the slot, you will find that placing a fire brick over the stock while heating it, will assist in getting a thorough heat in your stock. This method, if followed carefully and by an experienced welder, will result in the successful welding of stock of any reasonable width.

O. L. T., New York.



## The Automobile Repairman

### A Trio of Practical Automobile Hints

OSCAR STONE

The engravings will give you an idea how to get at nuts in unhandy places and have more freedom to work. The handle, A, can be made any length desired. The handle, B, is used to disconnect the Buick engine cylinders from their base. These handles are made of 1/2-inch round stock, the end being squared to fit sockets loosely.

The roller bearing sleeves on the Ford car are difficult to replace. The bearing slips into the housing for the sleeve. Then there is a small projection that slips into a hole in the housing. To get the sleeve out, drive a wedge between sleeve and housing on side where the projection is. Then take the tool, D, and slip the knob into the oil hole. Now

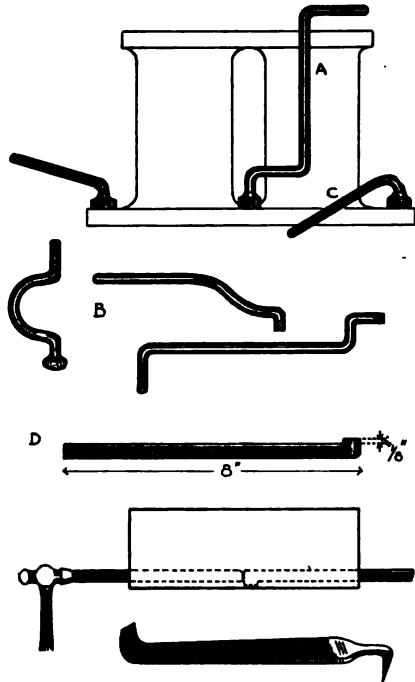

SEVERAL PRACTICAL AUTOMOBILE HINTS

with a piece of round or square iron slip through the housing against the knob, and hit with a hammer. See the engraving. Make the knob  $\frac{1}{2}$  round, and just  $\frac{1}{8}$  inch long or less. Make it the thickness of the bearing sleeve or a fraction less and slightly hooked. If you understand the principle of the tool you will know what I mean. To make the tool a success, it is made of steel not tempered. The idea is to get the knob short enough so that it won't go into the oil hole in the housing.

To make a key puller from an old file, round up the handle end, turn down and draw out to edge at bend to give strength. Don't temper. Can be made of any kind of steel stock, but it's a good way to bring old files into use. Turn other end in opposite direction to hook.

## A Practical Method of Turning Rough Brake Drum

VICTOR W. PAGE

In relining the external constricting brake bands of a popular make car recently, it was noticed that the brake drums were very badly scored their entire width. This not only reduced the effective braking surface materially but would cause premature depreciation of the new brake bands if they were assembled on the worn drum. The first thought was to remove the drums and place them in a lathe so they could be

trued up by taking a light cut across the face. This meant taking the axle shaft and wheel hub out of the axle in order to support the parts in a lathe. The car was equipped with removable wire wheels so this would not have been as bad as removing the brake drum from a wooden wheel hub. The thought came, why not use the rear axle as a lathe and turn the brake drum by engine power? The brake band supporting and anchorage pin member would make a very satisfactory tool rest, a large flat file could be easily touched up on an emery wheel to make a very practical hand turning tool of the round nose type. The car was jacked up on one side and the wire wheel removed to gain access to the drum. The engine was run slowly with the change speed gearing in reverse, and the drum was soon rendered smooth enough for all practical purposes by the cutting action of the hand tool which soon leveled down all the ridges. The same scheme could have been worked with the conventional wooden wheel, though not as handily as the illustration shows.

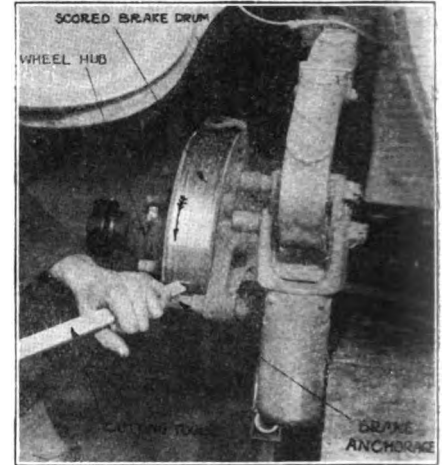

SMOOTHING DOWN A SCORED BRAKE DRUM

evenly spaced each side of the center line.

It will be seen that the bevel ring gear may be placed at either side of the pinion when the rear construction is reassembled. This is very easily done with the axle illustrated as the differential gear is carried by the axle shafts which revolve on roller bearings. If the gearing is not assembled correctly, the motorist will find that his high speed or direct drive will give a reverse motion instead of ahead. It will be found practically impossible to get into the high speed, as the engine will stall. It will also be noticed that the slow speed pedal of the planetary gearset will produce a reverse motion, while the reverse pedal must be operated to obtain slow speed. The correct assembling is such that when standing at the rear of the axle, looking down upon it, the ring gear will be at the left of

## Assembling Light Car Rear Axle

VICTOR W. PAGE

A word of caution should be given when reassembling the rear axle, and that is, to be sure to get the driving gears back correctly. Many light cars have what is termed a "symmetrical" axle, as illustrated. In this, both sides of the differential housing are the same and both wheel driving shafts are the

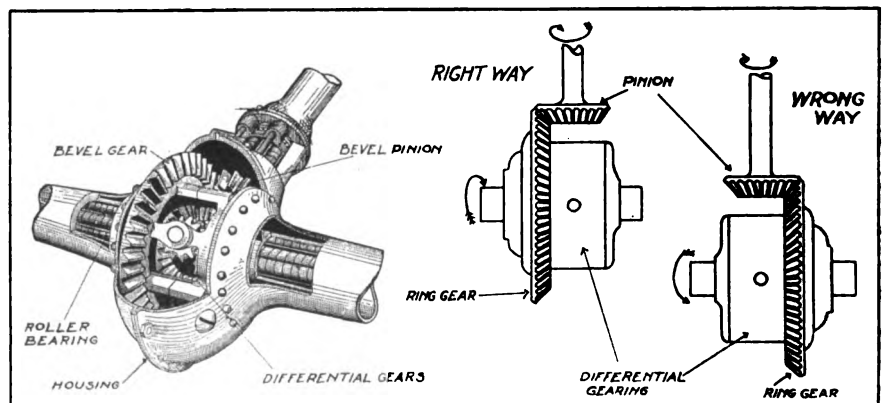

ASSEMBLING THE REAR AXLE OF THE LIGHT CAR MAY BE INCORRECTLY DONE

same length. The differential mechanism has its center line coinciding with that of the pinion shaft, and the supporting bearings are

the pinion. If it is replaced so it is at the right of the pinion, the direction of movement will be reversed, as clearly indicated in drawings.



# TIMELY TALKS WITH OUR SUBSCRIBERS

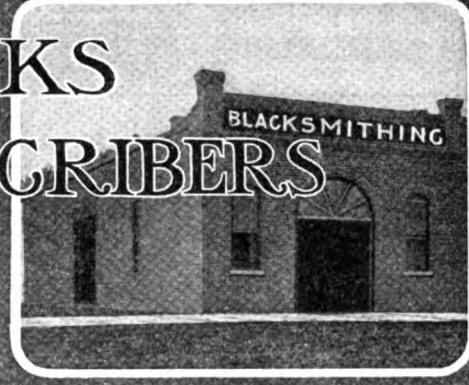

The American Blacksmith is published monthly at The New Sidway Building, Buffalo, N. Y., U. S. A., by The American Blacksmith Company. Incorporated under New York State Laws. Entered, February 12, 1902, as second-class mail matter at Buffalo, N. Y., Act of Congress, March 3, 1879.

William F. Wendt, President  
 Associates: James Cran - Bert Hillier - A. C. Gough - Dr. Jack Seiter  
 Albert W. Bayard, Secretary  
 Walter O. Bernhardt, Editor

Subscription Price: \$1.00 per year in advance, prepaid to any postoffice in United States or Mexico. To Canada, \$1.25; other countries, 6 shillings. Reduced rates to clubs of five or more on application. See "Honor Roll" page for money-saving, long-time rates. Cable address, "Blacksmith," Buffalo. Lieber's Code used.

Subscribers should notify us promptly of non-receipt of paper or change of address. In the latter case it is necessary that you give us both the old and the new address.

### A Larger Paper

Can you imagine what an improvement would be possible in "Our Journal," if between now and a month from now, it were possible for us to increase the number of American Blacksmith readers by just double the number of readers we have at present? Not only would we be able to give you a bigger paper, but with the increased number of readers, we would naturally be able to publish even a greater variety of articles. It may be impossible to double our number of readers in one month, but if each present reader secured but one other reader, there would, of course, be just twice as many smiths opening and reading "Our Journal" every month. Surely it is not an unreasonable thing to ask—that you get just one new reader for our paper. Furthermore, we make it worth your while, and you will be the gainer, not only in direct reward, but also in a better and bigger paper that must naturally follow.

It is naturally worth something to us to get a new reader and to make it worth something to you we will give you six months credit on your own subscription account for each new subscriber which you send us, or if you prefer a premium, take your choice of a Genuine Leather Combination Bill-Fold and Card-Case—a Pocket Knife—a rubber Stamp Outfit containing your name, business and address—a large Chart of the Horse—or Toy's Colored Steel Chart, and book on Steel Working. Secure one of the above premiums free of charge by getting your neighbor smith to subscribe.

### Subscription Agents

When a stranger solicits your subscription to THE AMERICAN BLACKSMITH or any other publication, insist upon him showing you absolute proof that he is an agent in good standing and is employed by the publication which he represents. Don't under any circumstances, give the man your money if you are not sure that he really works for the paper he says he does. No matter what the man offers you—no matter what price he makes—no matter what premium he promises to send—Don't Give Him Your Money If You Are Not Sure.

### Contents, March—1917

'Bout Time You Put on the New Coat! Frontispiece .....	132
The Oxy-Acetylene Plant .....	133
Oxy-Acetylene Welding Hints .....	136
Points to Watch When You Hire a Broker to Sell .....	137
A Big Pacific Coast Shop .....	138
Are You Buying Now Against Rising Costs? .....	140
Teachers of Blacksmithing Classed With Graduates in Latin .....	141
The Smith Gets Back at Farmer .....	141
Advance in Auto Construction .....	141
How Many Tons of Coal in a Pile... ..	142
The Smith in the Daily News.....	142
Blacksmiths Stop Long Credits... ..	142
Horseshoe Unlucky This Time.....	142
Blacksmith Tats Centerpiece .....	142
Pennsylvania Shoers Raise Prices. ....	142
Les Darcy, Blacksmith Pugilist... ..	142
Raise Prices .....	142
New Jersey Singer Helped Father at Forge .....	143
Sales of Horse Nails .....	143
Is It The Town—Or You? (verse).. ..	144
Heats, Sparks, Welds .....	144
Our Honor Roll .....	145
The Machine and Tool Smith.....	146
Boring and Grinding .....	146
Gas Engine Operation Made Simple—6 ..	149
Price List of Kansas Association ..	150
A Horseshoe for Luck! .....	151
"The Smith, an Honest Man is He". ..	152
Bending Brass and Copper Tubing... ..	152
Benton's Recipe Book .....	152
To Make Varnish Adhere to Metal.. ..	152
A Paint for Canvas .....	152
Coloring Copper .....	152
A Blow Hole Filler .....	152
Silvering Mirrors .....	152
Is Retreading Tires Successful.....	153
Queries, Answers, Notes .....	153
The Automobile Repairman .....	155
Motor Knocks .....	155
Curing Engine Misfiring at High Speeds .....	156
Another Advance in Steel .....	156

### Real Worth

Not only worth the subscription price do readers consider The American Blacksmith, but it is a common thing for a reader and subscriber to find the value of a full year's subscription in one little item. For example: Mr. E. F. Carson, Chaseburg, Wis., writes: "I read a little article in the January issue, which was well worth the price of a year's subscription to me."

This is not an exception—this is not the experience of just one man—this is not an isolated case. It is a common thing for a reader to find not one, but numerous hints—not one formula, but numerous formulas—not one article, but numerous articles that fit right into the work he is doing. The American Blacksmith is close to the man in the shop. It is the right hand helper of the practical smith.

But you cannot get full value out of its pages by simply reading them, looking at the pictures and studying the advertisements. You must read, study and apply the hints, kinks, methods and formulas that are presented to you. The amount of value you get out of the paper depends upon the amount of time, study and consideration you put into it.

### A New Series of Articles

Since the Oxy-Acetylene Welding and Cutting plant has taken its place in smith shop equipment, The American Blacksmith has kept pace with the times by publishing sound, practical articles detailing Oxy-Acetylene equipment and the care, operation and manipulation of the Oxy-Acetylene torch and plant. Beginning with this number a new series of articles on Oxy-Acetylene Welding and Cutting will appear. These articles are by David Baxter and will continue for several months. Beginning with a description of the plant and its equipment, Mr. Baxter will go into the details of the operation of the plant, manipulation of the torch and the preparation of the work in hand. Primarily these articles will be of special interest to the beginner and to the new owner of Oxy-Acetylene equipment. However, the expert and experienced operator will find much of value, interest and practical worth to him in this series of articles.

If you haven't now, an Oxy-Acetylene plant in your smith shop equipment, read these articles, follow Mr. Baxter along the lines of Oxy-Acetylene work and then seriously consider this opportunity for added business and increased profit.



**'BOUT TIME YOU PUT ON THE NEW COAT!**

Hasn't that Business of yours outgrown its Old Coat? It's pretty nearly time you discarded it and put on the New One—if you want to keep company with Little Sister any longer. Old Prices no longer fit today's Business, and you owe it to yourself to keep up with the times. Others have put on their New Coats; there's no reason under the sun why you shouldn't too.



# The Oxy-Acetylene Plant

## Its Installation, Operation, and Torch Manipulation

DAVID BAXTER

**N**EARLY every one possessing any mechanical knowledge is familiar with welding as it is done by the blacksmith. Most mechanics are familiar with the fact that the blacksmith cannot make welds that are commercially successful, of any kinds of metals except steels and wrought irons. With the Oxy-acetylene process, any kinds or combinations of metals may be successfully welded. This is accounted for by the fact that the welding flame is so very small compared with the intensity of its heat. The extreme high temperature of so small a flame admits of its being concentrated and easily localized and controlled. One may fuse together pieces of very large castings, bit by bit, until the break is knit together into one homogeneous piece.

Ordinarily, blacksmiths would find it impossible to handle such castings or other parts of metal, to say nothing of their ability to weld them. The oxy-acetylene welder finds cast iron one of the easiest metals to fuse or weld. A few blacksmiths can weld this metal after a fashion and even then it is of little value as far as strength is concerned. Other metals such as copper, bronze, aluminum etc., are readily handled by the oxy-acetylene method.

Oxy-acetylene welding consists of fusing, melting or flowing together two or more pieces of metal either with or without the addition of new metal, as it might be termed.

One can readily understand how fusing or melting together two parts of a broken casting will make it as strong as it originally was, if one remembers that the casting was melted and poured into that shape. It stands to reason that if the ends of the broken parts are like they were in the first place and thoroughly mixed together, they will possess their full original strength. However there are certain changes which may take place under certain conditions that will harm or weaken

the metal in the weld. The changes are of a chemical nature and are no fault of the process. The nature and cause of these changes will be taken up later under proper headings.

The oxy-acetylene torch operator employs at least one of the old time blacksmith's methods, which is hammering. The expert operator will use a hammer a great deal in his work, especially when welding steels and wrought irons. By tapping the weld as he builds it up he knits the metal more firmly together, making

a stronger, more even weld. By experimenting with the manner of hammering the beginner will soon learn just what is best in hammering different metals. This means just how heavy the blows should be and in what direction to drive the soft metal, also the duration of the hammering before adding new metal. In some cases it is best to finish the weld completely before doing any hammering.

There are two common systems employed with the oxy-acetylene process—the low pressure and the

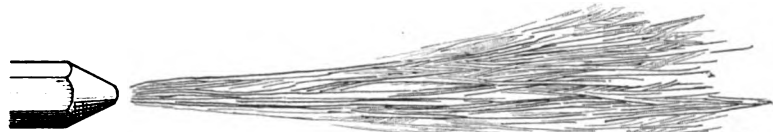

Acetylene turned on with sufficient pressure so that it burns away from the tip slightly—same appearance as "steam" coming from a tea-kettle.



Oxygen turned on, uniting with the acetylene. A cone begins to appear in the center, shaped somewhat like a rosebud, blue-white in color. This is what is called a carbonizing flame—that is an excess of acetylene or not enough oxygen.

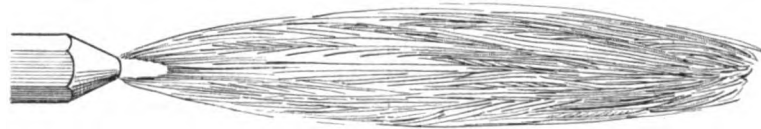

Properly adjusted or neutral welding flame. Cone in center is sharp and distinct, somewhat blunt. Ragged edges of the rosebud cone of the figure above just disappeared.

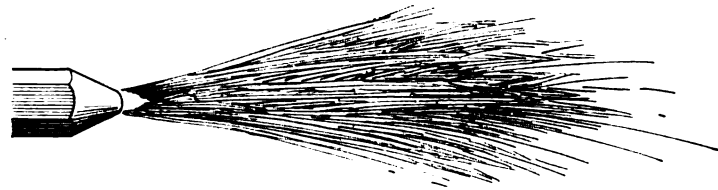

Too much oxygen in this flame, so it is termed an oxidizing one. Cone is shorter than in the above figure, more pointed and a different color, changing from the blue white to a darker blue. This flame is most easy to get and will ruin the weld.

FIG. 1.—PROPERLY AND IMPROPERLY ADJUSTED OXY-ACETYLENE FLAMES



high pressure. The low pressure delivers the acetylene directly to the torch or blowpipe under a pressure of a few ounces. The high pressure delivers the acetylene at a pressure of over one pound per square inch. Both have their advantages and peculiarities. The high pressure system is the one referred to throughout these articles, and as we believe most of the readers are more or less familiar with the generating apparatus we will not attempt to go into this subject. Besides it is better to follow the maker's directions about generating the gases. However, we would recommend that the pressure of the

traction and expansion is greater or less in different metals. It is also greater or less in the same metals of different textures. That is, soft cast iron and very hard cast iron have a different amount of expansion and contraction. Remelting numerous times changes the texture of cast iron. This explanation is given to remind the torch operator that all cast iron is not the same and may require different methods of welding.

Most of the metals have a marked difference in the same kind of metal. Like cast iron they are not all of the same texture. For instance, aluminum will melt at a certain tempera-

will illustrate the idea.

Still another problem is carbonizing. Or in other words changing to carbon. Carbonizing is explained by science as changing the carbon content, but it is hardly necessary to go into details because the average operator will not need to know it.

When the term hardening is used, it is meant, causing the metal to become difficult or impossible to file or machine. We will take up the main and minor difficulties again under different headings. There we will endeavor to point out clearly their causes and effects and ways in which to control them; in some cases to even make them work to our advantage.

The main idea for the beginner to grasp, is that the two pieces of metal to be welded are not merely to be stuck together so they will not break apart; but they are *to be melted together*—run into one piece. The perfect weld is one piece, not two, merely glued together. Let the operator see the difference in his mind and he will readily understand. Picture two pieces glued together and two melted into one. If it were possible to stir the melted parts like we would stir batter we could make the ideal weld. The object sought in making welds by the oxy-acetylene process is to melt the parts together without changing the nature of the metal. Try to fuse them so they will be as near their original state as possible.

A few words concerning the gases, and we then take up welding proper. Acetylene is composed principally of carbon and hydrogen. When acetylene burns with oxygen at the tip of the blow-pipe only the carbon in the gas assists in the burning, forming carbon dioxide. The temperature at the tip of the flame is too high for steam to exist, as it disintegrates between 2000 and 3000 degrees F. Therefore the oxygen cannot combine with the hydrogen to form water but must assist in combustion of the carbon in the acetylene. The hydrogen that passes away does not combine with the oxygen of the air until it has left the high temperature of the flame. The high temperature makes it possible to produce a very rapid fusion without burning the metal.

Oxygen is obtained by passing electricity through water and extracting the oxygen from it. It is then furnished to the operator in drums or "bottles." This is the best and cheapest way to obtain this gas. So we will not go into the de-

acetylene gas not be raised over thirty pounds as it is a useless risk.

Most of the failures in the past which have usually been attributed to the process itself, are almost without exception due to two causes: either poor equipment and accessories, or faulty handling on the part of the operator through ignorance or carelessness.

Purchasers of some of the welding plants now on the market are lead to believe that all that is necessary is to buy a machine. All makers should recognize the worth of stating fully all of the facts about the process. If their salesmen would state, that while it is difficult to make good welds, it is *not* hard to learn to make them; they would prevent much disappointment and greatly promote the development of the process. The manufacturers will go a long way toward placing the process upon a firm basis by emphasizing this fact in their catalogs and circulars.

The greatest difficulties to be contended with are contraction and expansion. This is not only true in oxy-acetylene welding but in every form of metal work. Foundrymen and blacksmiths, from the beginning, have had to contend with it and as a result have learned how to control it almost completely.

All metals expand when heated and contract upon cooling. This con-

ture and if the heat is carried on up a great way beyond this, extreme hardness results. This hard metal is difficult to do any thing with, and requires an extremely high temperature to remelt.

If the torch operator is observing he can soon learn to judge the textures with the naked eye, as they all show characteristics by which they may be known. Perhaps not distinct and accurately enough for very fine work, but near enough for the common run of work.

The word texture has been used herein, because it is believed the operator will grasp its meaning more clearly, than if he were told about carbon silicon content. The characteristics referred to will be dealt with under headings of different metal welding.

Another thing to look out for in welding is oxidizing. This is the burning or consuming of the metal by fire or heat, or we might make it clearer by saying, the changing from metal to powder or gas. This powder is called oxide. For illustration: put a piece of zinc in a fire or hold it in the flame of the welding torch a few minutes and it will burn, giving off a great deal of smoke which changes to whitish flakes. These may be rubbed to a fine powder and are called oxide of zinc. Of course all metal oxides are not formed in this way, but this

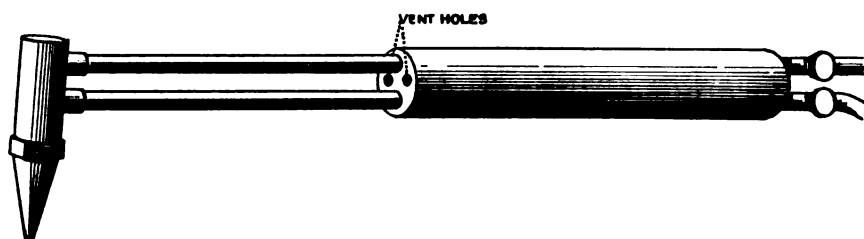

FIG. 2.—A TYPICAL OXY-ACETYLENE TORCH



tails of its generation at home, although this can be done by any welder.

#### Buying the Welding Plant

The welding plant should be chosen with an eye to several qualifications: First let us consider the factor of "safety-first," always.

Under certain conditions, positive hazards are bound to exist. It is the control of, and at least partial elimination of these conditions that we must look to in order to insure safety. It is said familiarity breeds contempt, when in reality a person should have greater respect for danger as he becomes more familiar with it. And no doubt more accidents are chargeable to *carelessness than to ignorance*.

The author knows a case in which a man tries to make an oxygen generator, using a small tank and common pipe fittings. He tried to fill the tank from the "cooker" with out cooling and without safety valves. The result was his death and a complete wreck of his apparatus. The tank was blown to pieces. Another carelessly left the valve between the "cooker" and tank closed. The result was not fatal but demolished the retort and frightened the man half out of his wits. Still another neglected to change the water in his acetylene generator. The carbide piled up and slid into the water in a greater quantity than was intended; this caused a sudden heavy pressure which blew the feeder off the tank.

The above instances are quoted to show the operator *that he must be careful at all times*. The idea is not to lead the operator to believe the welding apparatus is like a cantankerous mule and apt to kick his head off any minute. Quite the contrary; it is to impress upon his mind the necessity of being careful.

With the coming of the improved automatic machines and the use of oxygen in drums, it is only a matter of following instructions implicitly.

Modern apparatus is made as near foolproof as knowledge of the process permits. A first class equipment made by a responsible manufacturer is reasonably safe. It will pay any one to buy a dependable machine even if it costs twice as much. Some of the automatic machines are a marvel of accuracy and will pay for their extra cost in the satisfaction of being able to weld without continually feeding the generator.

One may buy the acetylene in "bottles" the same as oxygen, but as yet it is considerably cheaper to generate this gas in a plant at home. Of course the "bottled" gas is almost indispensable, where work cannot be brought to the shop. Its portable feature strongly recommends its use but one may have a generating outfit and still use it, by attaching the hose and regulators of the generators to the drums, attaching them again at will to the generator. It is advisable to buy a welder having a generator included. The factor of danger is less when using "bottled" acetylene, but if one buys a generator from a responsible firm the danger is minimized. A responsible maker cannot afford to equip his generator with cheap or inaccurate gauges or regulators. And even so it is well to remember that any kind of mechanical device will wear out sooner or later, therefore it is advisable to test out the gauges and regulators every few months. The

structed to withstand the working pressure. Any leakage of acetylene may be detected by a nauseating odor. Learn to know this smell by practice before using the outfit. It may save trouble from sudden leaks which should be stopped immediately.

A safer machine to buy is one having greater strength and capacity than is absolutely necessary. Added to this, one having the maximum protection against fire reaching the gas stored within it. The flame should be forced to pass the greatest permissible number of quenchers or traps. These traps are designed with the idea of extinguishing the flame before it can reach the main body of gas.

Always be on the lookout for leakage in the tanks, piping or hose. And even though you are certain there are no leaks, do not go about the generator with the blazing torch in your hands. You can never tell when a leak will start through corrosion, or springing of the connections. Put this motto in your shop—"SAFETY-FIRST," and *observe it*. Don't wait until you are given time to think it over in the hospital—do it now.

It is well to buy a welder that is especially adapted to your work, but it will never be amiss to buy a larger generator than is considered needful. It is much better to have *more* power than is ordinarily required, than to strike a heavy job of welding and be unable to generate the pressure needed. It costs no more to generate gas in a larger sized plant and you will use it up any way.

It is economy to buy a fully equipped outfit with all torches and their tips. It is not absolutely necessary to have more than one each of the welding and cutting torch, or more than one combination torch. But it is frequently very handy and economical to have two or more in readiness. This is not only of value in saving time, changing torches in case one clogs; but a better weld is often made if two torches are employed at the same time. It is better to be over prepared, than to be handicapped by insufficient equipment.

I would suggest experimenting to find out if several torches fastened together, or a new kind of torch having an adjustable multiple head with several flames burning at one time, could not be used on extremely heavy jobs.

(To be Continued)

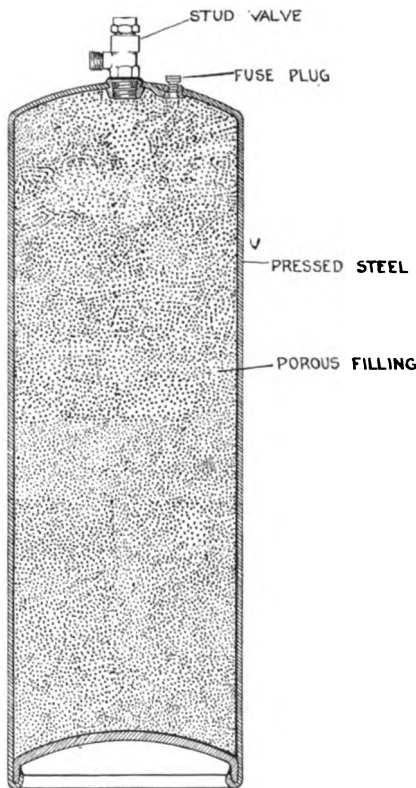

FIG. 3.—SECTION OF ACETYLENE GAS TANK

depreciation of acetylene generators is usually rapid.

One thing that increases safety is plenty of water to wash and cool the acetylene gas. A generator designed to use 50 pounds of carbide should carry at least 50 gallons of water, and should be rigidly con-





## Oxy-Acetylene Welding Hints—2

J. N. BAGLEY.

After learning the correct flame that is adapted to the line of work, the next step toward successful welding of steel as well as any other metal, will be the proper size flame for the job. In case the metal to be welded is very heavy the flame must be heavier to correspond, for in case a small tip is used on heavy work the metal will radiate the heat so rapidly that it would be impossible to get the proper heat to weld the work. The torch should be held at such an angle, on irregular work, as to heat heavier parts to correspond to the light ones, or the light portion will be burned. This is particularly noticeable in welding a heavy piece of steel to a lighter piece.

In welding heavy steel beams, etc., the welding must not be crowded too fast or the weld may not be done well. Plenty of time must be taken and the work well melted, care being taken not to overheat the welding, or filler rod. The edges of the casting must be chamfered off to allow the filler rod to be worked in, and in case the casting is heavy it should be chamfered from both sides to allow the weld being made from both sides. Steel will weld much different than the cast iron for it will not flow, but instead bridges across and leaves a space in the bottom that is not welded. Steel differs from other metals in many ways, and one of the particular things that the operator will notice is the possibility of welding it in any shape, that is, it can be welded from the bottom side as well as the top, or it can be welded in a perpendicular position.

Heavy parts that will require a great amount of gas to weld should be pre-heated in some sort of a furnace before welding as the heat will not radiate as rapidly as it will in case the pre-heating is omitted. There are many different ways, of doing the pre-heating, but the best and most satisfactory is to heat the work to be welded in a bed of charcoal as it will hold the heat well and has no bad effect on the steel, as will some other method. Many prefer to use the kerosene burner which will answer very well in most cases, except that the heat spreads and makes it more difficult to get close to the work. A bed of charcoal will keep the casting hot for hours after the weld, which has the advantage of preventing a crack from the ex-

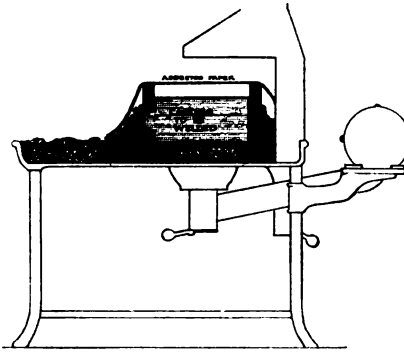
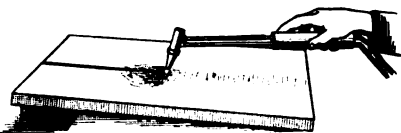
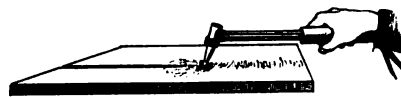

FIG. 1.—PREHEATING IN A FORGE

pansion and contraction. Charcoal also improves the quality of the steel rather than destroys as will be noticed as it is used.

In welding sheet metal considerable skill is required, especially in case the metal is unusually thin. A small tip must be used, as well as a small filler wire. The torch should be played with a circular motion and not held in one position or the metal will be burned rather than melted.

The amateur should not attempt large heavy work at first, but instead should begin with small pieces which have no value. Then if they are spoiled no one will be disappointed. The writer has found from experience that it is by far the best plan to turn a job down than to make a failure of it, as many do. Never take a job that you know you can not handle for it is a waste of time



FIGS. 2 AND 3.—EASY WAYS FOR THE BEGINNER TO LEARN HOW TO USE THE TORCH

and gas and results in a disappointed and dissatisfied customer, and these customers are a very poor advertisement.

Cast iron will be found the easiest to weld of any of the metals, because of the fact that the metals will flow very easily and go to the bottom of the chamfer. Yet it will burn quite easily and become brittle. Cast iron that is over heated will have very little strength, in fact it will break nearly as easily as glass. One thing which should never be

overlooked in the welding of any of the different metals is good flux. This one thing is more important than one might imagine in the welding of metals, especially cast iron, as it has a tendency to stand in bubbles on the surface of the casting, especially in case the surface is a trifle rusty or greasy. Cast iron welding differs from steel in that the metal must be laid in a horizontal position and welded from the upper side. Vertical welding can be done by an experienced operator where necessary, but it is not advisable to try it unless there is no other way to do the job. In case there is dirt and rust in the metal it must be worked out when the metal is puddled. Because of the fact that cast iron is the most inelastic of all metal used for commercial purposes, it presents a most difficult problem to take care of the expansion and contraction after the casting has been welded. This applies especially to the castings such as cylinders, etc. The filler stick should be prepared especially; soft grey iron, high in silicon and low in carbon.

Many operators complain of the hard and soft spots in the metal after welding. This comes from the molten filler stick coming in contact with other parts of the metal which are colder. When this takes place it indicates that the welding tip is a trifle small and does not keep the work as hot as it should be and a larger tip should be used.

Aluminum differs from the other metal in welding, inasmuch as it will not flow, but instead must be worked with a steel spatula, or rod to break the bubbles and spread them. A good flux should be used to break the oxide. The gases should be regulated so there is an excess of the acetylene gas rather than of the oxygen. Where the shape of the casting is such that expansion and contraction will have a bearing on the job, the work should be heated in an oven of some sort and welded while heat is on, after which it should be placed in air slacked lime, or left in the oven with all air shut away until entirely cool. The work should be covered with asbestos paper while welding for two reasons; the heat from the casting will not bother the operator, and the outside air will not strike it so readily. All parts to be welded should be cleaned of dirt and grease, and in case some sort of aluminum solder has been used all the solder should be



removed from the surfaces to be joined before attempting to make the weld.

In case some part of the casting has been lost, the part to be puddled in should be backed up with a cement of some sort, particularly adapted to the work. This will answer as sort of a support and the metal will not fall through. In case the job is an aluminum case the first thing to do is to make a shaft and bolt into the case to prevent the bearings getting out of line. Allow this shaft to remain until the case is entirely cold.

After the job is finished the torch should be played in a circular motion over the metal that has been used to make the weld, getting a little farther away each time until the metal has all reached the same temperature when it can be placed away to cool where the air cannot strike it. This method throws the strain on a very small area and there is less liable to be a crack or a check in the work, and there is less chance also of a warped or distorted case after the welding.

The welding of malleable iron requires quite a little skill as it is a very peculiar metal to handle. It can be welded very easily with cast iron rod, but it leaves the weld no stronger than the cast itself and should not be used only in special cases where it can be reinforced sufficiently to make the job strong

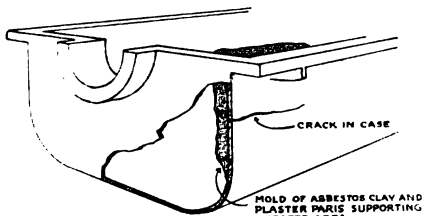

FIG. 4.—A BREAK CAN BE BACKED UP WITH A MOLD

enough to withstand the strain. Steel makes a very good weld so far as the weld is concerned, but the casting will not be strong because of the fact that either side of the weld the casting will be very brittle. One of the best welds can be made with tobin bronze and it is very easily worked and the work can be reinforced sufficiently to give the necessary strength. The proper heat for the casting to be welded should be reached before the bronze is applied, or the bronze will be overheated before it will flow and adhere. It is a very good plan to bank under the crack with clay to keep the bronze from running thru

and getting over some part of the work where it is not wanted, and where it will take considerable time to remove after the welding is finished. This one thing should

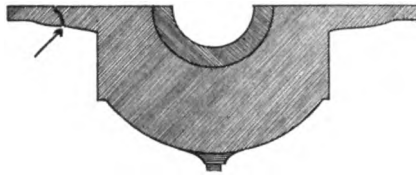

FIG. 5.—PREHEATING IS UNNECESSARY WHEN THE PART CAN EXPAND FREELY

not be overlooked in the welding of any metal and that is to use no more filler rod than is necessary as it takes time to remove the surplus metal, which only makes the job more expensive. The operator to make money out of welding should be able to trim his job with the torch, without however using an excessive amount of gas in doing the work.

The welding of brass is very easy and the flame should have an excess of the acetylene and the white cone should not be allowed to come in contact with the metal as it will burn it very quickly, thus taking all the strength out of the weld.

### Points to Watch When You Hire a Broker to Sell

Cincinnati, Ohio.

About three months ago I decided to sell my shop, and did a little advertising without result. I then placed the matter in the hands of a broker of this city and agreed to pay him 3 per cent. commission if he obtained me a purchaser for the business on my terms. It was quite a good-sized deal, as some real estate was included. I fixed a price on it and told him I would not sell for any less.

He had the business for about a month when he brought a buyer to me, who got the details, and said he would think it over and let me know. In a few days he came back and said he wanted to deal direct, as he did not like the broker. As I thought I would not have to pay commission, I agreed to sell to him for about \$500 less than the price I had made before, because that price included the broker's commission. The broker now says I owe him commission anyway, and says there is a clause in the agreement as follows:—

In case the said business shall be sold to any person obtained or

influenced by the said broker, the said broker shall be entitled to the said commission even though the purchase should be consummated between the said purchasers direct.

My position is that I do not owe this man a dollar, as the buyer refused to deal with him and it was not sold at the first price. Please advise me.  
R. O. P.

There isn't the slightest doubt but that you are obligated to pay the broker his full commission; and if you do not pay him he can get a verdict against you in any court in the United States. The case in my judgment does not admit of argument.

When a business man employs a broker to sell his business or to sell his house, or to sell anything, it is exceedingly easy to get tied up so that he will be obligated for a commission when he thinks he isn't. Usually a broker will insist on the client signing a contract, which *should always be read with exceeding care*. One such agreement which was brought to me bound the owner of a business to pay the given broker commission *no matter who bought it*, after it was placed in his hands, whether the buyer was obtained by him or not! Usually, however, brokers' agreements are reasonable, and merely provide for the payment of commission where a deal is made with a buyer which he obtains.

The law of such cases, in substance, is this: A broker employed to sell something on certain terms is entitled to commission where he is the moving factor in the sale, either by obtaining a buyer and carrying the deal through, or by merely obtaining a buyer and letting the parties make their own deal. He must be the responsible reason for the sale. And even if the sale is finally made on terms other than those which the seller first made, the broker is entitled to commission, if sale was made to his buyer on any terms.

For instance, there is a well known and very recent case in which the owner of a valuable piece of real estate employed a broker to sell it. The broker was employed through the following letter: "The price of the property will be \$275,000, out of which we can allow you a 5 per cent. commission. The property has been offered to others, hence this price is subject to prior



sale." This was a coal property and the broker interested the secretary of another coal enterprise in it and wrote the owners that he was sending an engineer to examine the

gotten, take the deal in his own hands and refuse to pay the broker *because* it is in his own hands, the broker can always be robbed of the fruits of his labor.

suit. He lost his case, the court ruling that what he did obviously had nothing to do with the sale. But once it is determined that the broker got the buyer, it makes little or no



EXTERIOR VIEW OF THE S. S. ALBRIGHT "DAYLIGHT" AUTOMOBILE PLANT, WHICH IS ONE OF THE MOST COMPLETE OF ITS KIND ON THE PACIFIC COAST

property. Some time later the owners wrote that the property had been sold and, upon inquiry, it developed that the purchaser was the president of the coal company to whom the broker had introduced the property. The price paid was much lower than the price quoted to the broker. Thereupon the broker brought suit for his commission. He proved that it was through his means that the parties had been brought together, although after that he had had no part in the transaction, and the court said he was entitled to his commission.

This is only fair. If the owner of a business or a property can employ a broker to get a buyer for him, and as soon as the buyer is

The real point in most of these cases is, *did the broker really get the buyer?* Hundreds of times brokers have sued for commissions when they did not interest the buyer at all. For instance, in a Pennsylvania case, a man whom I will call A had been negotiating with B to purchase the latter's shop. The negotiations got nowhere, and six months later B put the business in a broker's hands. B went right to A as the logical man to buy the business, and there was some little negotiation, but not much. Six months more elapsed, and A, whose circumstances had meanwhile changed, got into the matter again on his own responsibility, and this time bought. The broker demanded to be paid, and when refused, brought

difference what happens afterward—the broker can still collect his commission.

(Copyright, by Elton J. Buckley.)

### A Big Pacific Coast Shop, Devoted to Every Phase of Automobile Construction and Repair

Sacramento has one of the largest and best equipped plants for automobile work of all kinds to be found west of Chicago. This is the new "Daylight Plant" of S. S. Albright, at Thirteenth and U Streets, which was recently completed and is now ready for business.

The plant occupies a quarter of one of the city blocks. Before it was

constructed, much attention was given to all details, with the idea in mind of facilitating the handling of an automobile as it progressed through the shop for the various phases of the work to be done. After much study, a system was evolved by Mr. Albright which has proved practical in every detail and a car moves from one department to another in the various stages of the work without loss of time or duplication of energy.

One of the features of the plant is the saw-tooth roof, designed to give the most light at all times. By this arrangement all of the work rooms of the plant are light at all times. This is a very important item, as daylight is the best of all work, and lighting bills are kept to the minimum.

A short description of the various departments follows:

Starting from the office, the first department that is entered is stock room No. 1, where bolts, screws, tires, springs, wheels, paints, var-

nishes, oils, greases, etc., are kept in systematic order. Nearby on a mezzanine floor is stock room No. 2, where the spring steel—flat, round and octagon—is kept in neat racks.

Next the visitor enters the main blacksmith shop, where the spring repairing and building department is seen, and here all springs are manufactured and repaired. The spring furnace is heated with gas, which gives and holds an even temperature at any desired degree. The leaves are tapered by machinery instead of by hand, this method being quicker and cheaper. After being formed, the springs are tempered by oil in a special vat made for the purpose, surrounded by flowing water which keeps the oil at an even temperature. One feature here is a gas meter on each machine, by which the exact amount of fuel used on each job can be quickly and easily computed, which is an important point in figuring the cost of the job being done.

The tire setting block is built in

the floor, and there is a hydraulic press of the latest type, weighing six tons, with a pressing capacity of 200 tons, used for fitting on Kelley-Springfield truck tires. Adjoining this department, and conveniently located, is the body building department, where there is a complete equipment of wood-working machinery for the purpose. Adjoining this on the mezzanine floor is a stock room where all material for wheel building is kept. Choice lumber for the bodies is carried in racks and is not permitted to be placed on the floor, even temporarily. All waste material is thrown automatically onto trucks and the floor is kept clean and free from waste, at all times.

Next is the trimming department and here are manufactured the tops and seats and all kinds of seat coverings, etc. Sewing machines run by electricity, and thus easily and accurately operated, are one of the features of this department.

Above the trimming room is the reading room for employees. This is

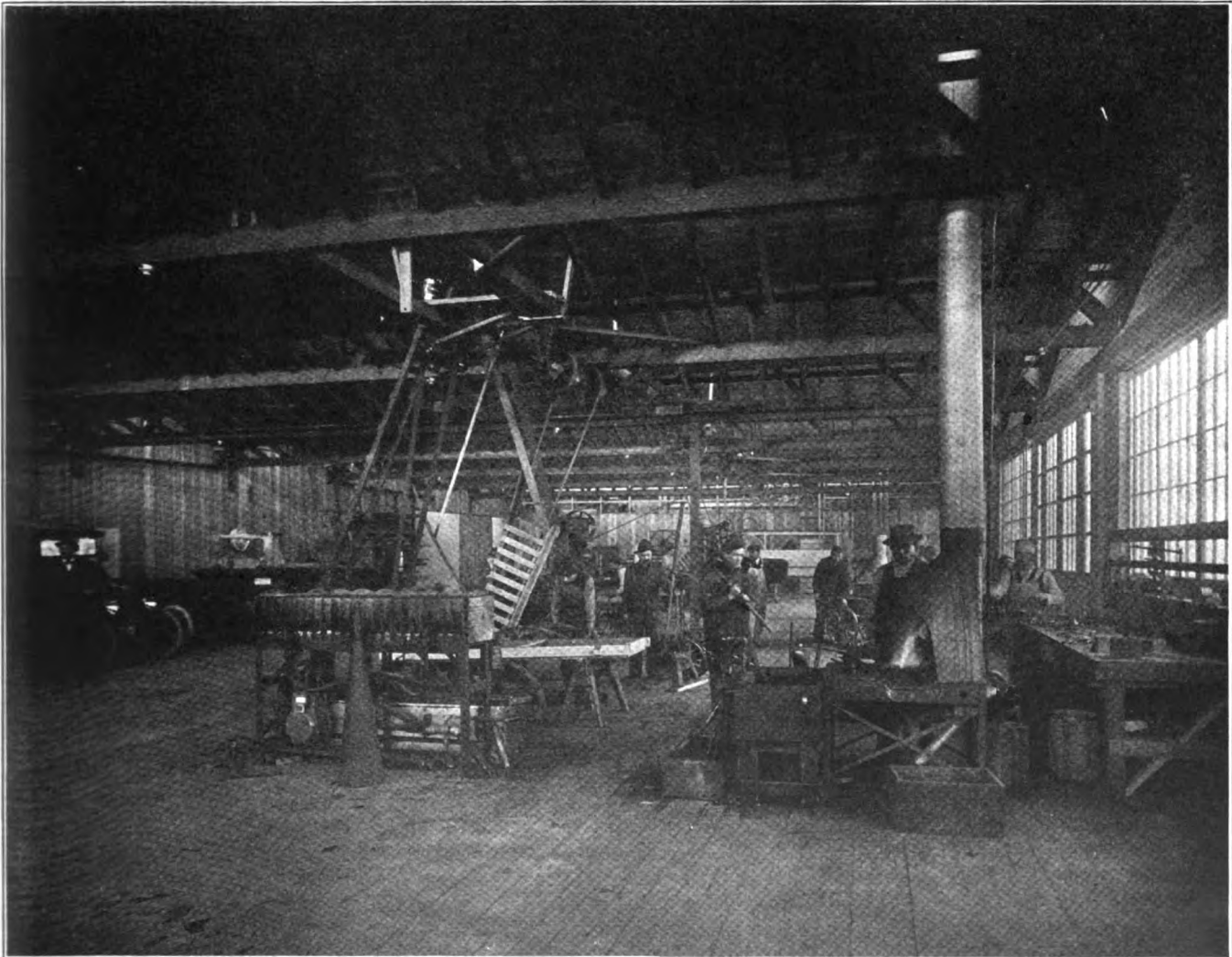

THE BLACKSMITH SHOP IS ONE OF THE BUSY DEPARTMENTS OF THIS BIG CALIFORNIA PLANT



equipped with thirty lockers for use of the workmen. It also has shower baths for the benefit of the employees. The reading tables are supplied with all the latest trade journals and technical books, and employees spend much of their spare time here reading up on the latest ideas in automobile construction. This room is also equipped with first-aid cabinets in case of accident or fatigue.

Conveniently adjoining the wood-

be easily moved from one department to another at any time; specially revolving so an entire wheel can be painted while the painter stands in one position.

From the paint shop the visitor enters the varnishing rooms of which there are two. In the under coating varnish room there are three ovens, gas heated, which are regulated by instruments to any degree of heat desired. The car next

of motors, 160x160 feet, having installed machinery costing \$40,000, so that now they will be able to do work which has to be sent out of the city heretofore. They are also putting in a battery department and service station. These two concerns can practically build an automobile under this one roof, and expect to be employing 150 men within a year.

### Are You Buying Now Against Rising Costs?

A subject close to the heart of every knight of the forge these days, is the rapidly advancing prices on iron and steel products; and the fact has been conceded by those in high authority, that it is utterly impossible to determine to what extent and proportion prices will reach by the end of this year.

The general direction of international affairs seems to promise no relief in the present high prices, and reports indicate that they may go even higher.

The American Blacksmith recently conducted an investigation of market conditions, and while some of the manufacturers questioned would give little satisfaction on the subject, the general consensus of opinion seems to be that costs will increase for some time to come.

The makers of calks, shoes, etc., are generally using up steel now that was purchased months ago, and as soon as they are forced to buy raw metal at present high prices, they will have to sell way below cost, or advance prices. During the past year, it is estimated that the price of raw material, labor and supplies has advanced over 100%, while generally the prices of horse shoes and the like have only advanced in the neighborhood of 40%.

It would be a good plan, in view of existing conditions, to lay in a stock of material in anticipation of future need before prices soar any higher. We suggest that wherever possible, that you at least give orders in advance that you may protect yourself on present market prices. Don't hold back, hoping that a decline will take place in prices. Chances are you'll get left, and then be forced to turn down jobs on account of scarcity of supplies. And by the way, don't be afraid to advance your own prices on shoeing; others are doing it and it's no more than honest that your shoeing prices should compare with

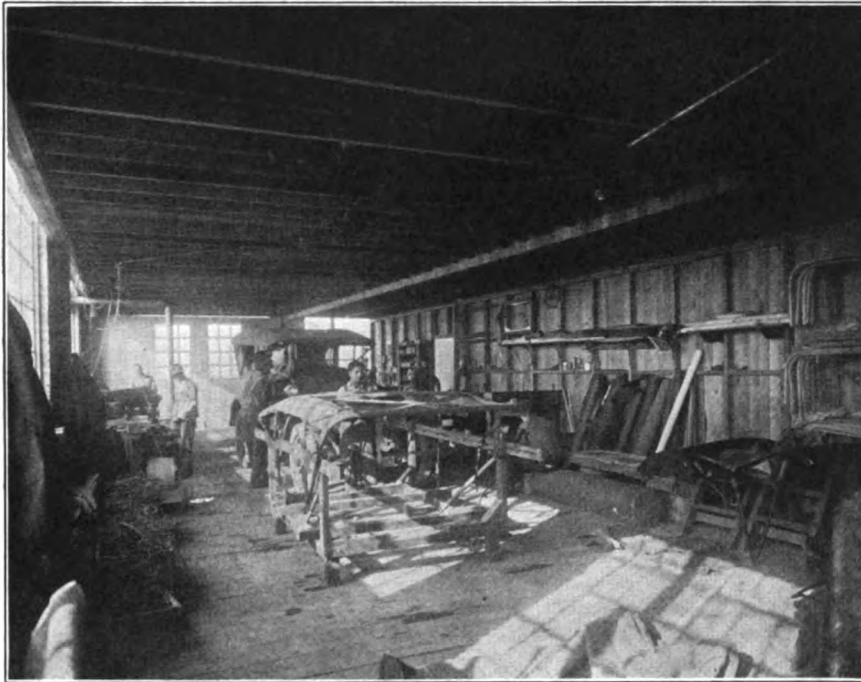

AN INTERIOR VIEW OF THE TRIMMING DEPARTMENT. HERE ARE MANUFACTURED TOPS AND SEATS, SEAT COVERINGS, ETC.

shop, blacksmith and trimming department is the paint shop, which is equipped with a steam boiler attached to which is a hose with a fine nozzle, used for the purpose of cleaning motors by the latest method most approved by experts. Another feature is a cement vat containing lye-wash, heated with steam, by means of which fenders and other parts of automobiles are easily freed of old paint. There is also a specially equipped paint mixing room, where the formulas used in the mixing of paints are those which have been used by Mr. Albright for the past twenty-five years here and in various Eastern factories; therefore tried and true.

On the mezzanine floor over the mixing room there are a series of racks where the lamps, wind shields, etc., from each car in the shop are kept separately, so as to avoid any loss to their owners.

All cars that are in the paint shop are placed on trucks so that they may

goes into the finishing varnish room, where the striping, lettering, etc., is done. This room contains four bake ovens, two of which are large enough so that a car can be placed therein without removing the top. These rooms are dust proof and no one is allowed in them except the finishers.

The final department is the setting up room, where the car is assembled and made ready for delivery to its owner.

The plant is so arranged that all material is stored overhead out of the way of the workmen, the work passing from one department to another and always toward the point of exit.

The plant occupies 30,000 square feet of floor space. It is steam heated throughout and lighted by electricity. At present Mr. Albright is building a number of jitney busses, hearses, delivery bodies, trailers, etc.

In connection with this plant Skinner and Hansen are putting in a shop for the construction and repair



ONE OF THE SPACIOUS SHOPS OF MR. ALBRIGHT'S UP-TO-DATE PLANT. NOTE THE "SAW-TOOTH" CONSTRUCTION OF THE ROOF.

high prices on every thing else. Don't cheat yourself. That seems more likely with the honest members of the craft, than cheatin' the other fellow.

Then too, profit is not wholly a matter of selling—you can make your profits just as well on the buying end.

So keep your eyes on the changing market conditions, and jes' use a little good ol' hoss sense in how, when and what you buy.

### Teachers of Blacksmithing Classed With Graduates in Latin and Greek

In a discussion before the Committee on Elementary Schools in Philadelphia a well-reserved tribute was paid the blacksmith by Dr. John C. Frazer associate superintendent of schools.

The particular case before the committee was the recommendation by the superintendent of schools, for the advancement of teachers of printing in the Trades Schools.

The discussion took a wide range, extending from the particular case of Mr. Henry to historical contests between the classical and the utilitarian in the lives of nations.

Thomas Boyle based his objection mainly on the argument that the 25,000 part-time children have superior claim to all the spare money. Simon Gratz threw down the challenge to Dr. Frazer about putting the chairs of blacksmithing, Latin and Greek on the same level.

"Do you mean to say," he asked, "that you would put the man who comes out

of the blacksmith shop to teach blacksmithing in the same class with the graduate in Latin and Greek of the universities and colleges?"

"Yes, sir, replied Dr. Frazer, "I am by trade a locomotive machinist and a graduate of a Greek and Latin classical course and one of the engineering board of instructors of Columbia University. I say that the properly trained instructors in printing and blacksmithing and other vocations ought to be given equality of recognition and treatment in the national system of education. It is essential to the preservation and progress of the Nation."

### The Smith Gets Back at the Farmer

He Shows the Soil Tiller the Other Side of the High Cost o' Living

While the village blacksmith toiled manfully over the old farmer's plowshare, the owner of the share recounted at some length the wonderful success he had had with the three litters of pigs he had marketed that day.

"Them pigs were less than eight months old", the farmer ran on, "and they brought me 10 cents a pound, or a little more than \$400. Why, a few years ago those same pigs would have brought me only half as much. I tell you, the farmer is having his harvest now."

The smith, having finished sharpening the share, handed it to his customer. From a well worn purse the farmer took two dimes, the usual price for the job, and dropped them into the smith's hand.

"You'll have to come again" said

the smith, still holding the money in his outstretched palm. "I charge 30 cents since the first of the year for sharpening that size plow."

"Why, how now?" the farmer exclaimed testily. "That's an outrage. Why have you raised the price on me?"

"To buy some of that high priced pork you were tellin' me about," was the smith's calm reply.

### ADVANCE IN CONSTRUCTION Time Has Brought Great Change in Automobiles

The remarkable advance in automobile construction in recent years has been marked not only by decreasing purchase price of pleasure cars, but also by the decreasing cost of their maintenance.

In early days cars were heavier and constructed of baser metals. Power was wasted through insufficient attention to the efficiency of carburetors and countless other minor, though significant details.

Time has brought a change. Today the automobile industry in America is one of the most efficient branches of manufacturing in the world. Not only have systematic methods of production been

## NOTICE

To Friends and Customers

On account of advance in prices of Horse Shoes, Nails, in fact all iron and material and labor, I am compelled to make a reasonable advance in the charges for horseshoeing and other work. No. 1 and No. 2 horse shoes will be five cents a foot more, and an additional five cents a foot for No. 3 shoes, and so on.

### New Welding Machine

I have recently installed a machine to weld aluminum and cast iron, and broken parts made of cast iron can be successfully welded and made as good as new at reasonable charges.

### Blacksmithing and Auto REPAIRING

I do all kinds of blacksmithing and woodwork, automobile and garage work, upholstery, tops and all trimmings made for automobiles. I also repaint automobiles and buggies and give the best of satisfaction.

Frank Teuber

PHONE 43 CORDELE, GA. 7 STREET, N

A SAMPLE OF WHAT ONE PROGRESSIVE SMITH IS DOING. THIS WAS REDUCED FROM A LARGE NEWSPAPER ADVERTISEMENT

developed to the highest perfection, in order to meet competition in decrease of price, but especial care to the refinement



of detail has been exercised in construction.

The economy of maintenance of low-priced cars today would be unbelievable to the automobile owner of a decade past.

## Can You Tell How Many Tons of Coal There are in a Pile?

W. F. SCHAPHORST

Here's a chart that will show you how. Try it on some of the boys and they will think you are a wizard. It is also mighty useful in estimating how much coal there is in a pile you may be about to buy.

The following description explains "how it works:"

Column A gives a table of different diameters of piles from 2 feet up to 100 feet.

Column B gives the number of tons, figuring 2000 pounds to the ton.

Column C gives the number of tons on the basis of 2240 pounds per ton.

And Column D, the height in feet from 2 feet to 100 feet.

For example, we will take a pile 20 feet in diameter and 10 feet high—which dimensions can be roughly estimated in any pile.

Now look up 20 feet in Column A (where we have drawn the dotted line through).

Next look for 10 feet in Column D and the line drawn between these two points will cross column B and C, at about 29 on B and 25 on Column C.

This shows that the pile contains 29 Tons of 2000 pounds each, and 25 tons of 2240 pounds each.

A pile of coal 20 feet in diameter and 10 feet high is very unusual however, because the "angle of repose"—that is, the natural slope of the coal, would hardly be that great.

The angle of repose for anthracite is about 27 degrees, bituminous coal, 36 degrees, and coke 40 degrees.

This difference is due to a variance of the adhesive qualities of the respective materials. That is, anthracite, being more slippery than bituminous or coke, would spread out over a greater area at the base and would not be as high.

So to find the approximate height to which any of these materials can be piled on a plot of given diameter, multiply the diameter by 0.25 for anthracite; 0.36 for bituminous coal; and 0.42 for coke.

The chart will tell anyone there-

fore, just how much coal can be piled on a given, level plot, a thing that is worth while knowing.

## The Smith in The Daily News

**Odd Mention of Anvil Ringers and Knights of the Forge in the News of the Day.**

### Blacksmith Will Stop Long Credits

The blacksmiths of Lompoc, California, held a conference at which time matters pertaining to business in their line were discussed and action was taken regarding the credit system.

Hereafter, according to a notice published, all blacksmith bills must be paid within sixty days. This notice is signed by the four local firms.

The blacksmiths give as their reasons for discontinuing a system of long credits as has been practiced in the past, the unusually high prices of iron, steel and other commodities used in their line of business, and the insistent demand of the wholesalers and supply men that goods must be paid for within thirty days.

### Horseshoe Unlucky this Time

John H. Higan, blacksmith of Ohio, does not believe a horseshoe is lucky. After walking over the icy streets, he entered his shop only to have a horseshoe fall and strike him on the top of the head. He was unconscious for some time.

### Blacksmith Tats Centerpiece

A tatting centerpiece made by James Cozard a Nebraska blacksmith, was a feature of the fancy work exhibit at the Farmers' institute at Stella, Nebraska.

This is certainly a very strange sideline for a blacksmith to take up, but when an occasional woman takes up the hammer and tongs instead of the rolling pin and dish cloth, why shouldn't a smith take up the tatting needle (?) or what ever is employed in the work.

### Pennsylvania Shoers Raise Prices

A general increase of 20 cents on all sizes of horse-shoeing has been announced by the master blacksmiths in Altoona.

The change in price will become effective immediately and notice of the increase in price was posted in all the master shops.

Under the new scale all shoes from No. 0 to No. 5 sizes will be \$2; No. 6 shoes, \$2.20; No. 7, \$2.40, and No. 8, \$2.60. Under the old prices the shoes from No. 0 to No. 5 cost \$1.80 with the larger sizes 20 cents higher for each size.

### Les Darcy, Blacksmith Pugilist Tells Success Secret

"I found when working as an apprentice to a blacksmith that the toughest metal weakened and gave under constant hammering, and when I began fighting in the ring I applied the hammer, hammer, hammer idea to the business."

That is the way Les Darcy, the Australian champion, explains his success as a boxer. The young man, who says he will enlist in a Canadian or English regiment and go to the front as soon as he

has made money enough fighting in this country to assure his family comfort, insists that is not the single punch that wins generally but the constant pounding away at an opponent.

"My work at the forge gave me great strength, of course," continued Darcy, "but it didn't tend to make me fast. A blacksmith is a pluggger, but by plugging he gets there, as anyone will in any walk of life. I learned to plug along while young and I have found it a very successful plan to follow in the ring. Of course I have developed speed, but I would rather be an out and out pluggger than a fast, clever boxer.

"Keep hammering away, punch your opponent at every opportunity and the result is sure. Drop a man with a punch on the jaw and he may get up before the count of 10 as strong as ever. But send a man down with a succession of stiff punches and the chances are he will stay on the canvas and probably have to be carried to his corner.

### Raise Prices

The blacksmiths of Mulenberg Co., Ky., met a few days ago and raised the prices on all work about 25%. I made enough clear over the old price yesterday to pay for "Our Journal" for 1 year. Tell all the boys through your paper who are not organized to hold county meetings to establish a living price, to have their prices printed on large card-boards, with each smith's name to head the card. Then have all the important work itemized and priced and tack up a card in every shop.

We have been working under this system since February first. When a customer comes in and wants to know the price of a job, just step to your price list. There it is in print, and when he sees the name of every smith in the county or city signed on that card, he is satisfied that one price prevails. Let me urge you brother smiths to stop accusing each other of price cutting and get your prices and names all printed on the same card. It will do more good than all the abuse you can heap on your competitors and even your customers will appreciate it. It shows you have some business ability.

J. H. LEWIS, Kentucky.

### New Jersey Singer Helped Father at Forge

Anna Case, appearing as the principal attraction at a concert given by The Trenton Male Chorus, at Crescent Temple, is a New Jersey girl. During all her girlhood years she lived at South Branch, Somerset county. Her father was somewhat of a singer himself. Her mother possessed a beautiful voice but circumstances prevented her becoming the consummate artist into which her talented daughter has developed.

A relative of Anna recently gave a characteristic anecdote in her life that may be considered worth repeating. The blacksmith owned a "one hoss shay" that did the family many services. There came a day when the blacksmith found it necessary to go to the city for some necessary purchases. He went by train, leaving the shop closed. Anna had to meet a relative at Belle Mead railroad station and drive over to South Branch. She harnessed old Brindle, but discovered two loose shoes in his feet. But this offered no obstacle to energetic Anna. She went to the shop,



started up the banked forge fire and proceeded to fit a new pair of shoes on old Brindle's feet, and a right workmanlike job it was. Probably this would never have been known but a neighbor heard the clanging of sledge on anvil and investigated, with the result that the strange worker was discovered.

Many times after that Anna officiated as "striker" for her father, and who can tell how much of her chest development has come about from this form of physical exercise, and how that development has assisted the singer later in producing her beautiful tones?

**Sales of Horse Nails**

A recent shifting in the sales of the various sizes of horse nails brings to light some interesting reasons for such changes. Some years ago there was a tendency to use smaller sizes of horse nails because they are sold by the pound to the consumer, and there are more small-sized than large-sized nails in a pound, so that the consumer got more nails for his money. He also found in general that the small-sized nails held the horse shoes on about as well as the larger sizes.

Lately, however, the sales on both large and small sizes have declined, while the sales on medium sizes have increased. This is true not alone in the city but likewise in the country. It appears that small-sized horses are not used nearly so much as formerly in buggies because Ford automobiles have displaced them. Also large horses have been sold to Europe in great numbers and, moreover, they are not used for draught purposes so much as formerly because of the growing use of automobile trucks for all manner of hauling. Meanwhile, medium-sized horses continue to be employed for farm work much the same as formerly.

Brief mention of a few careers which show that the knight of the forge is indeed a worthy and respected citizen:

**A Fireman-Blacksmith**

Oliver A. Terry, 81 years old, died at his residence in Riverhead, N. Y., recently. He was a native of this section and for sixty years conducted a blacksmith business and became one of the leading citizens of the town. As the first chief of the Riverhead fire department he rendered heroic service. He was a past master of Riverhead Lodge, F. and A. M., which honored him at his funeral services. He was also a past grand of Roanoke Lodge I. O. O. F., and was identified with the Junior Order United American Mechanics.

**A Student-Blacksmith**

Bartholomew J. Long, of Brooklyn, ended a long and successful career as a horse-shoer. He graduated from St. Vincent de Paul's Academy, and with a classical education to begin life with, entered the shoeing business of his uncle, which he followed up to the time of his death.

**A Citizen-Blacksmith**

John Wallace, for many years a blacksmith of Rochester, N. Y., passed away at his home at the ripe old age of 84. After having spent eight years in the gold fields of California, where he accumulated considerable of a fortune, he returned to his native city. Here he rendered worthy service on the city council and also served as a burgess. His active con-

nection with church affairs was well known; and he goes to rest mourned as a loved and respected citizen who has done much to benefit the community.

**A Churchman-Blacksmith**

Perhaps the fact that he was the son of a minister, caused Lewis H. Haney of Chambersburg, Pa., to devote a liberal share of his busy life as a son of Vulcan, to church work. At any rate he proved himself to be one of the most vigorous and ardent members of his community in

just been granted a patent for a railroad cross tie. Feeling that he was not properly equipped to manufacture it on a large scale, he sold out all rights to parties located in Portland, Oregon for the sum of \$8,750.00.

With the many problems which frequently confront the average smith, and which demand an original solution, it seems that the blacksmith should easily win the title in the heavy-weight class of inventors. It wouldn't be a bad idea, for some of them to work over those ideas

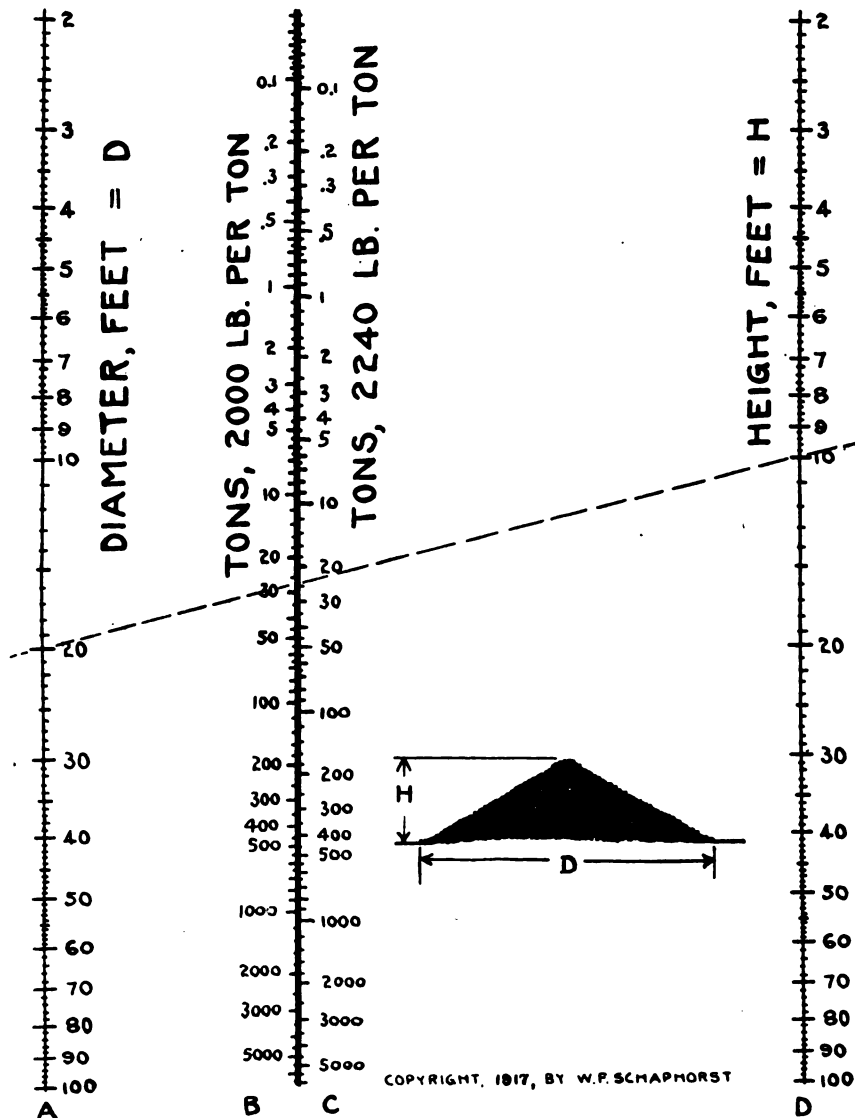

**A CHART FOR FINDING THE NUMBER OF TONS OF COAL IN A PILE**

helping others to lead a better life, and up to the time of his death at the age of 77 years, he was actively associated with the Second Lutheran Church, the Knights of Malta, and the Red Men Lodges.

Mr. Haney's blacksmith shop was long famed for the high character of its work. He seemed to devote the same conscientious attention to duty in his work as he did to his interests in church affairs, with the result that he had few superiors as skilled in the craft.

**A Blacksmith-Inventor**

Lute Dunning, a citizen of Petersburg, Ind., a blacksmith for many years, has

which they have been keeping under their hats for these many moons, and who knows but what a few of the grimy anvil hitters will soon join New York's Four Hundred!

**Another Smith Gets Into the Auto Repair Game**

George Leopard, a blacksmith for twenty years at Farmington, Connecticut, has closed his shop and connected with a big repair station in Hartford.

Which would seem to indicate that the "hoss business" was gettin' rather slow down his way, or else he saw more money and bigger opportunities in the automobile field.





## Is It the Town—Or You?

Farm Imp. News.

If you want to live in the kind of a town

Like the kind of a town you like,  
You needn't slip your clothes in a grip  
And start on a long, long hike.

You'll only find what you left behind  
For there's nothing that's really new,  
It's a knock at yourself when you knock  
your town.

It isn't the town—it's you.

Real towns are not made by men afraid,

Lest somebody else gets ahead.

When everyone works and nobody shirks  
You can raise a town from the dead.  
And if while you make your personal  
stake,

Your neighbor can make one, too,  
Your town will be what you want to see,  
It isn't the town—it's you.



## Heats, Sparks, Welds

Shorten your Credits and fatten your purse.

Of course, wise men make mistakes, but they don't repeat them.

Keeping the dead beat in mind and not on your books will save yourself both money and worry.

Some trade just wanders in, other trade you must go after, but is there any that you don't deserve?

A Western smith who had laid a new floor in his shop, advertised: "Come in and help wear out the new floor."

Did you ever think of your business in this way? If you were selling your work, services and goods to yourself, would you be entirely satisfied?

Every one makes mistakes, but it is not the making of them that concerns us most, but it is the repeating of mistakes that places us in the wise or foolish class.

Both are unfortunate conditions, though it is better by far to be a live man in a dead town, than a dead man in a live town. Tom Hardy comes under the latter classification.

It is not so much the customers you get who count, but the ones you keep. Careful attention and persistent attention to the keeping of customers will make the getting of them much easier.

It takes more than a leather apron, a strong arm, a hammer, an anvil and a forge to make a blacksmithing business. A good quantity and quality of brains

must be mixed into the combination somewhere.

Are you looking after your equipment properly? Remember, actual use will many times wear out tools, not one bit quicker than lack of care. Now is a good time to look over your equipment and to put it into proper shape.

Changes are bound to take place in the craft—they are taking place now. What do you think the results will be? Can you look ten, fifteen or twenty years ahead? What do you think the smith shop of the future will be like?

Advertising means considerably more than merely keeping your name before the public. There are thousands who keep their name before the public through the medium of the daily news, but some of those thousands are crooks and law breakers.

Your helper will be a better helper if you ask his help occasionally. Talk things over with him. You are paying him for knowing something, then why not take advantage of what he does know? The really big man is not ashamed to learn from the most humble source.

Village gossip and War talk are all right in their place but it is always good policy to mix in a little blacksmithing business between the war reports and the other gabbing, for you know after all is said and done, it is the smithing business that keeps the table set.

If you don't really know whether or not you are making a profit at the present prices, get right down to figures. There's nothing more convincing than actual figures in a profit and loss argument, and if you are making a profit or making a loss, figures will quickly show you.

Keep your finger on the pulse of your customer's wants, and when you see a need for anything that you can supply, do not hesitate to suggest your furnishing the necessary services. Take a lesson from the boot-black, he usually announces his wares when he sees there's need for his services.

You can please your pocket-book by putting your name on the Honor Roll. The saving you can make by taking advantage of Our Long Time Rates is considerable if you subscribe for a long period. Decide upon the amount you wish to save, and then subscribe accordingly. Is your name on the Honor Roll?

It takes a lot of money to carry on a private banking business in connection with a smithing establishment. If you are in the banking business, well and good, but don't try and mix it with smithing business. On the otherhand if you are in smithing business, don't try to do a banking business on the side.

Appearances may often lead a man astray, and this applies not alone to people, but to work as well. Clothes may make the man, but a high stepper may belong to a dead beat, and the owner of a great big touring car may be poor pay. Likewise, honest material and workmanship are the deciding factors between a poor job and a good job.

Do you realize that is not so much a question of time, but the use we make of time that concerns us most. When you find your self saying "I haven't time" just remember that you will never have any more time than you have right now. We have and we have always had all the

time there is—twenty-four golden hours every day. Make the most of each one as it is served to you.

Would you attempt to drive a horse, or to run an automobile if you were blindfolded? Yet some smiths try to run and to drive their business without paying attention to running expenses and costs, and then they wonder why they are continually so close to the "ditch." Eyes wide open and carefully kept books will show you just where you are running your business, whether into the ditch of failure, or on up the road to success.

Sit right down now and write out a description of that hard job you did recently. Tell American Blacksmith readers how you succeeded in solving a particular puzzling problem. They will be glad to know about it. Your brother smiths can learn from your experience just as you learned from theirs. How long will it take you to write a short article for publication? How long will we need to wait before hearing from you?

You can set a good example for your customers, by delivering a job when you promised it. Then when a customer promises to pay on a certain day, insist upon getting your money at that time. Point out to him the fact that you pride yourself upon delivering the goods when promised. A good example in this way will go far toward getting your customers into the habit of paying when they promised, instead of promising when they should pay.

Do you treat your telephone as an investment or an expense? It is a good collector as well as a business getter. It is a buyer as well as a seller. Don't miss the opportunity it presents for keeping in touch with your customers. Remind the slow payer of his promises—keep after those customers who have promised you jobs and business—announce the purchase of new machines, the employment of new men and the installation of new equipment, by means of the telephone. You can make it pay big dividends if you will use it right.

Are you grabbing opportunities as they are presented to you? How about the automobile opportunity that is with you right now? Have you grabbed that? Here is an opportunity for adding profits that are right in your line. If your shop is now fairly well equipped, you will need little extra equipment to take care of automobile work. It will not be long before the motor car and truck is again crowding our roadways. Prepare now to take care of this business if you have not already installed an automobile repair department.

Spring cleaning—is it too early to mention this? Better get at it before the Spring rush. And while you are doing your Spring cleaning, don't forget that collection of old tires, wheels and other junk that is littering up the outside of the shop. It doesn't add to your profit, it doesn't add to the appearance of your place of business, it doesn't increase the value of your property, it doesn't improve the appearance of the neighborhood. Why not clean it up and clear it out? Save up what is really worth anything, but do throw out the truck and trash. The chances are that you will get a bigger price for the junk now than you will at any other time. Scrap is bringing good prices these days.

Our Honor Roll

IT'S EASY NOW TO BE AMONG THE LEADERS.

Do you want to place your name among the leaders? It's easy now. If your subscription expires with the March, 1917, number, send in a little five spot (\$7.00 in Canada or 12 1/2 sh. in other countries) and your name will be placed in the March, 1917, class and you won't need to think about your subscription account for years to come.

If it doesn't expire this month, ask the Subscription Department when it does expire and how you can get into the leaders' class.

A NEW NAME IN FIRST PLACE?

The Fix-It Shop has held first place for some months, but we understand some one is planning to take the lead. A twenty-year order will clinch the lead for some one. Who will it be? Watch out for a new name in first place. Something's going to happen soon. Keep your eye on this Roll of Honor.

Table with 4 columns: U.S. and Mexico, Canada, Other Countries, and Subscription. Lists names and subscription amounts for various regions.

Send your order and remittance now—today. Don't wait until you forget all about it. You'll never regret it. Our subscription insurance saves you money. The sooner you begin saving, the more you save. There is no better time than NOW.

Main subscription list table with columns for NAME, Subscription Paid to, and various names and dates.

Subscription list table with columns for NAME, Subscription Paid to, and various names and dates.

Subscription list table with columns for NAME, Subscription Paid to, and various names and dates.



## The Machine and Tool Smith

### Fundamentals of Lathe Practice

Boring and Grinding  
JAMES STEELMAN

A useful appliance for use with the turning lathe is the *boring bar*. It may be a very simple, home-made affair. It need not be anything more than a long round bar in whose ends center holes have been carefully and properly made and at whose center is a short slot extending clear through the bar. By mounting this bar on the lathe, fitting the head and tail centers to the center holes and securing a suitable cutting tool in the slot, we have the means of cutting a cylindrical hole. An engine cylinder may, for example, be bored out with this arrangement. The work envelops the bar; so, before putting on the bar, we clamp or otherwise secure the work to the carriage. It is very important that the work be held very rigidly by the carriage, as otherwise we may have all kinds of imperfections in the hole we bore. The cutting tool extends perpendicularly from the bar and when the bar is turned by means of a *dog* rigged on the *driving plate* it does its cutting. It will be noted that here the tool turns and the work does not. However, it is necessary that either the tool or the work shall move longitudinally. Otherwise, there would be no feeding operation, and the cut would be only a single ring. The *feed* is secured by shifting the carriage along. This may be done in one of two ways—(1) by carefully turning the hand wheel, or (2) by putting the carriage and the lead screw into connection as when cutting screw threads. This latter is perhaps preferable, after one finds out how fast the work should move along. The advantage of the hand feed with the

wheel is that we may cautiously feel our way. But we may do much the same thing with the lead screw. We begin by arranging affairs so as to shift the work quite slowly; then we change the driving of the lead screw to a faster movement, if it appears desirable to do so. The cutting tool may be double-acting: that is, it may be arranged to cut at both ends simultaneously. This permits the work to advance more rapidly and has a valuable advantage of another kind. It will readily be understood that, when cutting is going on with a single-ended tool, the tool will tend to bend the bar slightly in the direction away from the point of cutting. When a double-ended tool is used, we have two such pressures, one against the other. Any inaccuracy in cutting due to the bending of the bar away from the cut will thus be done away with. However, with a double-ended tool, we may have more or less trouble making corrections for the wear of the cutting edges. Naturally, the tool would go on becoming shorter and shorter, thus boring the hole smaller and smaller. There are ways of correcting this, to which some attention will be given in a moment.

The slot in the boring bar is made with square corners. One side of the cutting tool may be placed right up against one of the end faces of the slot. Between the tool and the face at the other end of the slot, a wedge may be driven to hold the tool securely in place. The side of the tool against the end face of the slot may be given a perfectly flat surface to match the end face of the slot. This flat surface may be set in a trifle. There will thus be in a single-ended tool a shoulder which will assist perhaps in holding the tool up against the work and in resetting the tool after it has been removed for grinding or some other purpose. If the tool has two cutting ends, then there may be two shoulders. The opposite side of the tool—the side against which the wedge bears—may belly out a little for a double-ended tool or, for a single tool may have a slight taper. In either case, it may be found advantageous not to have the tapering on the tool quite as gentle as that on the wedge. The idea is to limit the contact with the wedge. Under any circumstances, see to it that the wedge bears against the tool at a point half way through the slot.

With a single-ended tool, the bending of the bar may often be

minimized by making the bar itself as substantial as possible. Naturally, its rigidity is increased by shortening it as much as the work and one's convenience permits. Further, the bar may sometimes be supported at points between centers.

As the double-ended tool cures a good deal of difficulty arising out of the tendency of the bar to bend, it may seem preferable to take the measures that may be necessary to offset the wearing away of the cutting edges. It is suggested that at times this may be done by lengthening the tool at two points, each of which is between the cutting edge and the boring bar itself. A slight tap with the hammer when the tool is quite hot may frequently suffice. Unless the tool is a pretty long one, we will have to harden and temper after the operation. Or, we may, if it seems best, simply lengthen the cutting tool just back of the edges by heating and then tapping with a hammer.

The boring bar need not be an accurate cylinder itself. It is only necessary that the center holes arranged at the ends be true with each other.

To get a true hole, we take off our roughing cuts and then finish with one or more very light cuts.

There are boring bars so arranged that the tool is shifted along the bar. It is then unnecessary to secure the work to the carriage. In some cases, it may be that the work may then be made more secure. These special boring bars can scarcely be depended upon, however, to do any better work than the old time bar with a slot in the center, provided one handles the work properly.

The boring bar provided with the shifting tool may often be used to bore out a taper hole. One way of doing this is not to use the regular head center which is in line with the axis of the spindle, but to set a *new center* on the *face plate*. The boring bar is now placed between this center and the center in the tail stock. It is not proposed to *rotate* the bar between these centers, but to *swing* it round. A *dog* is employed to prevent the bar from turning on the new center. A one-ended tool is now employed. The work may be secured to the bed of the lathe. This method of internal taper turning is not to be regarded as easily applicable to gentle tapers.

*Increasing the swing* of the lathe is sometimes a very important pos-



sibility. We may have a 12-inch lathe and need to handle a 15-inch job. The amount of large work may be insufficient to justify buying a larger lathe, and it may be enough to make us sorry to have to turn it away. When a customer goes from our shop to get one job done, he may get into the habit of going elsewhere later on with his ordinary work. One of the lathe authorities suggests using *raising blocks*, as he calls them. The headstock is raised and a raising block put between it and the bed; so also are the tool post device and the tail stock. Naturally, these blocks must be shaped on top in a suitable manner to receive their respective parts of the lathe, and on the bottom similarly with respect to the parts of the lathe with which they will come into contact. Possibly, such blocks could not easily be made at home and would preferably come from the lathe maker. All the same, their cost would probably be rather small compared to the expense of a new lathe.

The lathe may readily be converted into a *grinding machine*. This is important for those who have grinding to do, but do not see their way clear to purchase a special machine. In a typical grinding machine, we have some means of holding and rotating the work. This the ordinary lathe provides. It is ordinarily necessary also to feed the grinding wheel back and forth or else to feed the work itself. The lathe carriage supplies a means of advance and retreat, and may be utilized. What the lathe does not supply is a means of rotating the grinding wheel. Accordingly, in order to convert the lathe temporarily into a grinding machine, we look about to see how we may manage this. This may be done, and in a rather simple way. Before giving details, it may be best to consider what will be demanded. First, the grinding wheel must be rotated at a very high speed. Whatever means we use to effect the drive of the grinding wheel, it must be capable of performing its service notwithstanding the fact that the grinding wheel is fed back and forth. Further, it is very necessary that the grinding wheel shall rotate with very great steadiness. The very object of grinding a surface is to get it very exact. If the grinding wheel trembles, we will naturally lose accuracy. Now we may give the spindle which carries the grinding wheel great steadiness by using a *long bearing*. Then

we may get the speed we want by using a pulley of large diameter on a countershaft overhead and running a belt from this to a very little pulley on the grinding wheel spindle. The attachment containing the long bearing we secure firmly to "the tool clamp of the top portion of a compound slide rest". We thus get a means of making the wheel advance and retreat. However, what is going to happen when we advance the grinding wheel and in consequence the little pulley? We will disturb our belt drive. A method of overcoming this difficulty is not to use an ordinary pulley on the countershaft overhead, but a long drum of the proper diameter. Then, as we advance or retreat with the

spindle. If this can be accomplished at home, then the whole apparatus can probably be satisfactorily made by any one who is handy with mechanical things. The drum may be mounted on a special countershaft. This will have to be long enough to accommodate a small pulley in addition. The pulley may then be connected by belt with a good sized pulley on the main shaft. The construction of the drum need impose no great difficulty. It may be a *wooden shell* made up of slats or staves, the whole being held together on a wooden or steel framework. After the wooden strips have all been secured firmly in position, the surface may be turned to a true cylinder and finished with sand

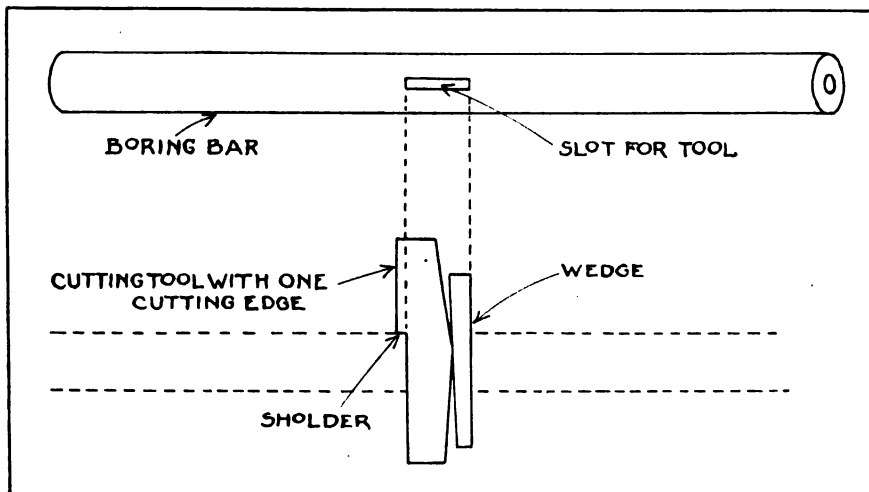

AN EASILY MADE BORING BAR

little pulley, the belt will shift on the drum. An important consideration in connection with the foregoing is that the whole apparatus may very properly be built at home. *The most vital part of the whole, so far as accuracy is concerned is the journal bearing or bearings of the fixture which carries the grinding-wheel spindle.* A very good way to construct the bearings is to provide three separate bearings—one on one side of the little pulley and two on the other side. These two should be separated, say, 8 or 10 inches or even more. The spindle will be carried on all three. At one end of the spindle will be the grinding wheel; at the other will be the little pulley and the single bearing next to it. The spindle should have its bearing surfaces accurately ground. And the bearing boxes in which they turn should also be ground with precision. The object in view should be to have the spindle turn readily when all boxes are tightened to the point permitting no play of the

paper. This part of the apparatus need not be especially accurate. Do not misunderstand me. I do not mean to say that this drum will work satisfactorily, if it is clumsily and inaccurately made. There is no good, however, in spending time and attention in an effort to make the diameter the same everywhere with such precision that no diameter differs from another more than 0.01 inch.

A little calculation will show that we may readily get high speeds. Suppose the main shaft runs at 150 r.p.m., that the pulley on it is 2½ feet in diameter, that the small pulley on the special countershaft has a diameter of 6 inches, that the drum is 2 feet in diameter and finally that the little pulley on the grinding-wheel spindle has a diameter of 1½ inches. Since the diameter of the main-shaft pulley is 5 times that of the small countershaft pulley, the countershaft will (neglecting slippage of the belt) turn 5 times as fast as the main shaft. The counter-



shaft accordingly will turn at 750 r.p.m. Now, since the drum diameter is 16 times that of the grinding-wheel pulley, the spindle will (neglecting slippage of belt) turn 16 times as fast—that is, at 12,000 r.p.m. Now the *cutting edge of the grinding wheel* should ordinarily run at the rate of about 6000 feet per minute. To get 6000 feet out of

up. If we have to deal with small holes of, say, 1-½ inches or less in diameter, then we should endeavor to get a higher speed out of the spindle. There are several ways of doing this. We may cut down the diameter of either of the small pulleys, or we may increase the diameter of the main shaft pulley or of the drum. Or, we may combine

erally, use good sized wheels. The work itself should be turned at the same time that the grinding is going on. A proper speed for the surface being ground is 100 feet per minute. This should not be confused with 100 r. p. m. If we have to grind soft steel, brass and metals generally, except hardened steel, cast-iron and chilled iron, then we shall find it advisable to have a yet higher rate of speed for the cutting edge of the grinding wheel—7000 feet per minute being a good average speed for the generality of metals.

As so much depends upon the accuracy of the movement of the spindle, an additional word may not be out of place. Vibration must be excluded. Accordingly, the two bearings between which is the little pulley should be close together. This will minimize the tendency of the spindle to bend at this point. This spindle should be rigid. It would seem then that it may very well be made of *tool steel*. The part carrying the little pulley may be made as large in diameter as possible to reduce bending. This enlarged diameter should include all that part of the spindle resting in the two bearing boxes.

In a grinding machine, it is important that the *work* be rotated accurately and without vibration. It is also important that the *means of feeding* the wheel back and forth shall operate with great precision. Both of these things are secured by the accuracy of the *lathe* and not by the accuracy of the home-made accessories I have been describing. It is the lathe spindle that rotates the work and not the grinding rig. The compound rest handles the feed and so we do not depend in feeding upon the home-made apparatus. We do depend in the home-made rig upon an accurately rotating spindle for the grinding wheel. If the smith can make this part, he ought ordinarily be able to make the whole. If he is not in shape to make the spindle holder, he can probably buy it. Even if he buys the whole outfit, the cost will be moderate compared to what would be the case, if a special grinding machine of equal capacity were purchased.

The drum may be made, it is understood, by using two pulleys of the proper diameter, each being, say 2 inches wide. Let these be placed at a proper distance apart—say, 3 feet. Strips of wood, each 1 inch wide, may then be secured to the pulleys by cap screws, the strips

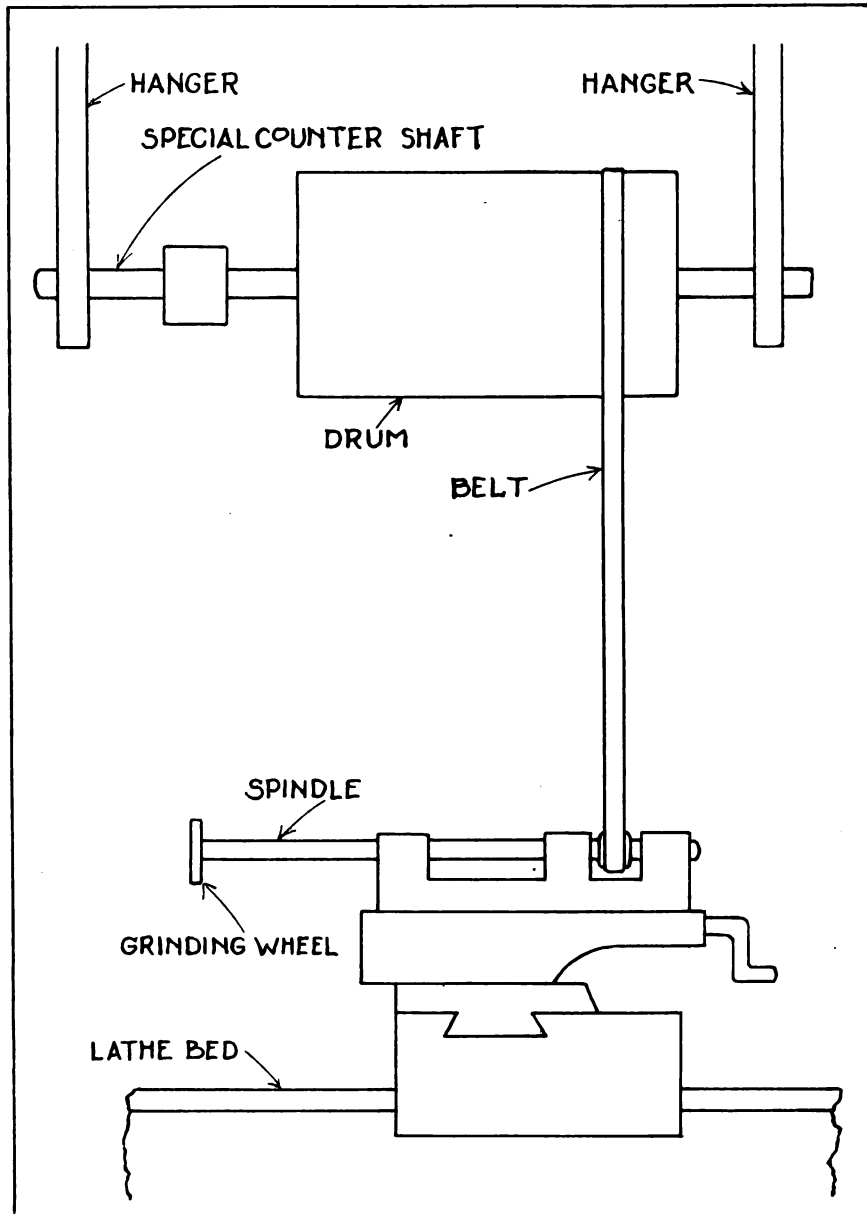

AN EFFICIENT RIG FOR THE GRINDING MACHINE

12000 revolutions, the grinding wheel will have to measure ½ foot on its circumference. If we use an emery wheel 2 inches in diameter, we shall have a circumference greater than ½ foot. Consequently, we shall get the required speed of the grinding wheel's cutting edge, if we use this size or even a size a trifle smaller. For *internal grinding* we should then be prepared to grind holes from, say, 2-½ inches

two or more of these things. In any case, *do not expect to do satisfactory grinding unless the cutting edge of the grinding wheel runs at about 6000 feet per minute*. Neglect of this caution will be apt to result in disappointment. It is sometimes useful to remember that the bigger the grinding wheel, the faster its cutting edge will move. Where we are concerned with *external grinding*, we may often, not to say gen-



being placed side by side until a cylindrical shell is formed.

Instead of driving the small pulley on the special countershaft by a belt running to a big pulley on the main shaft, we may connect with the regular *cone pulley* on the ordinary countershaft used in driving the lathe. By this means we may be able to get sufficient grinding wheel with a drum of smaller diameter. The reason for this is that the countershaft belonging to the lathe will probably run at a speed a good deal higher than 150 r. p. m.

## Gas Engine Operation Made Simple.—6

The Purchase, Installation, Operation and Troubles of a Gas Engine

J. L. HOBBS

Carburetion

Before entering on the subject of carbureters and mixers proper let us take a little time to find out the process of manufacturing the different fluid fuels which are to be used in the carbureter or mixer; as the understanding of the manufacture of the fuel will make the nature of it easier to understand.

Practically all the liquid fuels used in internal combustion engines are made from crude oil. The process of making is called refining and is really a process of distillation. Alcohol is beginning to be used quite a little as a fuel for this class of engines; it is manufactured from potatoes, grains, corn stalks, etc.

We will give you a general idea of the refining of oils. It is a very simple process and requires a very small amount of machinery and expense to perform the work. As a starter we will analyze 5 gallons of crude oil and show you what is made from it.

5 gallon of crude oil when distilled produces as follows:

2½ quarts of cylinder oil for steam engines.

1¼ pounds of vaseline or petroleum jelly.

3 quarts of spindle oil and axle grease.

5 quarts of gas engine oil, also used in automobiles.

1 pound of paraffin wax.

5 quarts of kerosene or lamp oil.

4 quarts of gasoline.

You will see by the above that only about 20% of the crude oil is turned into gasoline, 25% into

kerosene, and the remaining 55% is divided among all the other products of crude petroleum. Some of the by-products of petroleum have not been mentioned above but are included in others mentioned.

In taking up the process of the refining of crude oil it is not the purpose of this article to go into details merely as they interest the owner or operator of a gas engine. How the different products of gasoline are produced, such as ether, benzine, naphtha, etc., are of no particular interest to him, so will be omitted.

A refinery consists of a very large tank so constructed that heat to almost any degree may be applied gradually under the control of the operator of the refinery. Heat is the main thing used in the refining of crude oils. When the heat is applied and the crude oil gets up to about 80° F. the vapor begins to arise from it, which when taken through the distilling pipes and again reduced to liquid, proves to be a very high test gasoline or ether. As the temperature rises a little higher the vapor when distilled makes benzine. When the temperature reaches about 115° (which is the boiling point of gasoline) we obtain the gasoline generally used in gas engines and automobiles. There was a time when gasoline was cheaper than kerosene, then they did not make any more than was necessary to make kerosene safe, but since gasoline has come into such general use, quite a percentage of what used to go into kerosene is now mixed with gasoline. This accounts for the difficulties we now have in starting an engine on a cold morning.

When the point in temperature is reached where the vapor can no longer be turned into gasoline, it is turned into kerosene and kindred products, such as distillate and signal oil. This process is continued up until the temperature reaches about 350°, where the steam-cylinder, lubricating oil is secured up to about 400°. From this point up, the different grades of gas-engine, lubricating oil is produced up to about 900°. What is left then goes into petroleum jelly and fuel oil, nothing being wasted in the refining process.

Carburetion consists in reducing the liquid fuel to a vapor and mixing the vapor with the proper amount of air to make a high explosive gas which is used to run the

engine. There are two instruments or mechanical devices used for this purpose, the carbureter and the mixer.

The mixer being the simpler of the two, we will take it up first, as the discussion of it will help to simplify the carbureter. The mixer is used on the larger type of engines where a very small variation in the speed of the engine is required. It consists of a fuel bowl, a needle valve and an air intake, and a mixing chamber in which the vapor from the fuel is mixed with the air to make the explosive gas.

The fuel must be maintained in the fuel bowl to a certain height, which is about one eighth of an inch below the point where the opening from the needle valve enters the mixing chamber, this is necessary so that the suction of the air passing into the cylinder, after being mixed with the vapor, will draw more vapor into the mixing chamber in the form of vapor spray. This level is generally maintained by having an overflow pipe from the bottom of the mixer back to the fuel tank. The fuel being pumped into the mixer in much larger quantities than required, the surplus runs back into the tank through the overflow pipe. This is much simpler and much less apt to get out of repair than the float used in the carbureter for this same purpose.

The pump used for this purpose is generally of the plunger type with two valves, one above the pump and the other below it. These valves may be all brass, or have a brass seat and use a steel ball for the movable portion of the valve. Where a steel ball is used there is very little danger of the valve leaking, but if it should leak, place a small block of wood on top of the ball and tap it gently with a hammer until the leak stops. Where the all-brass valve is used, and a leak occurs it is necessary to remove the valve and grind it into the seat as will be explained in the chapter on Compression, where valve grinding is discussed.

A little experience will come in handy here. An engine was used in shelling corn. The pulley on the engine was too small and in order to run the sheller at the proper speed the engine had to be speeded up about 100 revolutions per minute faster than it was designed to run. The result was an increase in vibration. This excess vibration caused the little balls in the gasoline



pump valves to get up and roll around on their seat and allow the gasoline to run back into the tank, and the engine would slow down until the vibration ceased enough to allow the ball to drop back into its seat, when the pump would again supply gasoline to the mixer and the engine would again begin pulling its load. What caused this action of the engine cost a good many dollars in time of experts, but was very simple when located. The remedy would have been to put on the proper size pulley wheel, but the engine owner would not stand for the expense so there was only one thing left to do and that was to put in smaller balls in the valves so that they would set lower and stand more vibration without leaving their seat. When the small balls were furnished the engine ran just like it should have done at its rated speed.

The tank used on a stationary engine should if possible be outside of the building and buried at least two feet below the surface of the ground to keep the fuel at a uniform temperature all the year round, also as a precaution against fire. This will aid materially in starting in cool weather. Just pump the cold gasoline out of the pipes and mixer and allow it to run back into the tank through the overflow pipe and you will have gasoline which will vaporize easily; which is the main thing in starting. On a portable or tractor engine it is of course necessary to have the tank attached to the engine frame in some rigid way so that the piping will not be leaking and causing trouble. This will make it necessary to resort to some artificial means of starting the engine in cold weather, which will be taken up a little later.

The mixer so far described, is the one used for the handling of gasoline as a fuel. To use the less volatile liquids, a slightly different arrangement is necessary. It is always necessary to use a little gasoline to start the engine and get the cylinder warmed up, so the heavier oils will vaporize properly. To do this there are two ways in common use. One way is to have two mixers, pumps and sets of piping, and the other is to have a three-way pump with a double mixer which can be switched from gasoline to other fuel by the changing of the valves. Either of these ways is satisfactory, but in using either it is best to switch back

on to gasoline a few minutes before stopping the engine as it cleans the cylinder and piping and leaves the engine in much better shape for starting. If, however, the engine should stop before the change in fuel can be made, provision is made for pumping the kerosene out of the pipes and mixer by hand and substituting gasoline in its stead, by operating the pump a few times by hand.

It will be found necessary in burning these heavier oils, to have some means of preventing premature ignition in the cylinders when they get hot enough to handle the mixture made from the heavier oil and air. This is accomplished by having

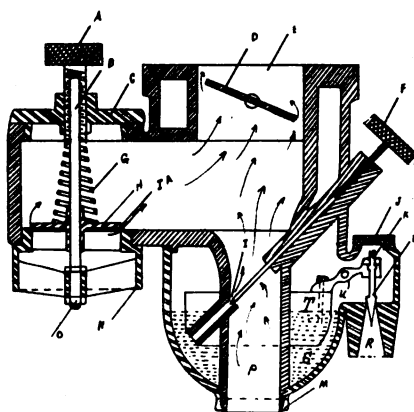

A SECTIONAL VIEW OF A TYPICAL AUTOMOBILE CARBURETOR

The following reference will explain the main working parts:

R—Inlet for gasoline	F—Regulating Screw.
L—Needle Valve	IA and P—Air Passages
S—Float Chamber	A—Regulating Screw for
T—Float	Air Intake Valve
I—Spray Nozzle for ad-	D—Throttle Valve
mitting Gas to Mix-	E—Passage to Intake
ing Chamber.	Manifold

a needle valve attached to a water pipe coming from the water jacket of the cylinder and arranged in such a way that vaporized water can be injected into the mixing chamber. This process makes a mixture which will not pre-ignite. This water valve is only to be used to prevent pre-ignition, as it is a detriment to your power when not necessary, and should never be used with natural gas or gasoline. Full instructions for operating these mixers are always found attached to a new engine or will be furnished by the manufacturer upon request. An oil burning engine running upon a full load will use about as much vaporized water in the charge as it does oil, but when not running on a load will not require any water vapor at all.

(To be Continued)

## The Price List of the Kansas Association

We have a Blacksmith and Wagon Makers Association with about 600 members. We are working for a higher standard among smiths so we can greet our neighbor smith with a hearty welcome instead of trying to cut his throat by cutting prices and putting him out of business and fighting him on every corner. Most every smith knows he is working too cheaply but cannot help it because his competitor is working against him. I say, be friends with one another and see what a difference it will make. You have got as good a right to live as I, but do not cut prices to get it. Move before you cut prices. S. F. PEMBERTON, Kan.

### THE KANSAS ASSOCIATION PRICE LIST HORSESHOEING

New Shoes	Each	\$ .60
Re-setting	Each	.35
Stallion Shoes	Each	1.10
Stallion Shoes, Reset	Each	1.10
Bar Shoes, Common	Each	1.10
Bar Shoes, Hand made	Each	1.50
Neverslip Shoes, New	Each	.90
Neverslip Shoes, Re-set	Each	.80
Neverslip Oaks	Each	.08
Trotting Horse Hand-turned	Each	1.25
Side and Toe Weight	Each	.90
Leather Pads with Packing	Extra Each	.30
Air Cushion Pads	Extra Each	1.50
Paring Horses' Feet	Each Horse	.30
Shoeing Bronchos and Fractious Horses	Extra	1.50

### WAGON IRONWORK

Irons on Front Bolster	\$ 1.25
Irons on Hind Bolster	1.25
New Bolster End Irons, Each Bolster	.85
New Bolster Stake Irons, Each Stake	.75
1 pair Bolster Plates	1.85
1 New Sand Board Plate Put On	1.65
4 Wagon Tire Out and Set	3.00
4 Tire Re-set	3.00
4 Tire Re-set and Bolted	4.00
4 Tire Pinned	3.00
4 Tire 8 inch Re-set	4.25
1 Rake Tire Re-set	.60
4 Log Wagon Tires Set	4.00
1 Set New Tire 8 inch	18.00
1 Set New Tire 1 1/2 inch	12.00
1 New Rub Iron Put On	.70
Old Tongue Iron Replaced	.70
Old Tongue Hound Irons Replaced, Per pair	.90
1 New Hind Hound Plate	1.25
New Hound Iron Braces	Each 1.00
New Hammer Strap	.65
New Circle Post	Each .35
New Tongue Cap	.90
New Tongue Rod	.60
New Tongue Plate	.30
1 New Wagon Wrench	.60
Hub Bands, Old	Each .20
Hub Bands, New	Each .35
King Bolt	Each .60
New Brake Shoes Put on	Each .50
Queen Bolt	Each .90
Box Strap Irons Put on	Each .30
Seat Springs	Each 1.00
4, 3 1/2 x 10 New Skeins with Boxing put in	10.00
1 New Skein Only put in	3.00
1 New Skein Boxing Only	1.25
4, 3 1/2 x 10 Steel Skeins	Extra 3.00
1 Geisler Brake Ratchet put on	1.50
Top Iron on Box, Bottom Box	1.10
Box Rods	Each .30
New Center Clips on Singletrees	Each .30
New Ferrule on Single-trees	Each .25
New Neckyoke Center	Each .60
Neckyoke Ferrules	Each .20
Seat Hooks, Set	.75
Rub Irons, Not Put on	Each .35
Hub Bands, Not Put on	Each .30

### WAGON WOODWORK

Bolsters, Front or Hind	Each \$3.00
Bolster Stakes, Front or Hind	Each .60
Set of Rims, 1 1/2 inch Thread	10.00
1/2 Rim, 1 1/2 inch Thread	1.85
Set of Rims, 2 1/2 x 2	12.00
1/2 Rim, 2 1/2 x 2	1.85
Set Truck Rims, 3 x 1 1/2	13.00
1/2 Rim, 4 x 1 1/2	2.10
Set Truck Rims, 4 x 1 1/2	16.00
1/2 Rim, 4 x 1 1/2	2.00
Truck Felloes, 2 1/2 or 3 inch	Each 1.55
Truck Felloes, 3 1/2 or 4 inch	Each 1.85
Wagon Felloes	Each .50
Wagon Felloes, Set	9.00

Spokes, Single	Each	.40
Spokes, Whole Wheel	Each	.80
Hubs, Per Set		6.00
Hubs, One		2.00
Reaches, 8 ft.		1.50
Reaches, 10 feet		1.75
Reaches, 12 feet		2.00
New Tongues, Oak or Ash with Old Irons		4.65
Flow Tongues, Oak or Ash		8.75
Sleigh Tongues, Square		8.75
Harvester Tongues		5.50
Tongue Hounds, New, Per Pair		2.50
Tongue Hounds, New	Each	1.50
Front Hounds	Per Pair	8.00
Front Hounds	Each	1.65
Hind Hounds	Per Pair	8.00
Hind Hounds	Each	1.75
Bent Hounds		4.00
Single-trees	Each	.85
Double-trees	Each	1.25
Neck-yokes, Old Irons		.90
Hub, Boxed	Each	.90
Axles, 3 1/2 x 4 1/2	Maple, \$4.00 Hickory	5.00
Axles, 4x5	Maple, \$4.50, Hickory	5.50
Sand Boards		2.50
Wagon Stakes		.40
Box Bottom, Labor		3.10
Box Bottom, Cross Piece Center		.90
Box Bottom, Cross Piece End		.60
Box Bottom, Per Set		6.00
Spring Seat, Wood		8.75
Seats, Old Iron	Each	1.85
Seats, New Iron	Each	6.00
Wagon Shafts, 1 1/2 x 2 1/4	Each	3.40
Dump End Gate	Each	1.85
Plain End Gate	Each	1.50
Wheels Out Down, Per Set Complete and Old Tires Set		15.00
Setting Boxing, New		.90
Setting Boxing, Old		.60
Setting Skein	Each	.60
Eveners, 4 horse, 6 ft.		2.60
Eveners, 4 horse, 7 ft.		2.50
Eveners, 4 horse, 8 ft.		2.80
Wagon Boxes, 12 inch		16.00
Wagon Boxes, 14 inch		17.00
Wagon Boxes, 16 inch		21.00
Double Box, 12 and 14 inch		25.00
Triple Box, 10, 12 and 14 inch		30.00

**BUGGY IRONWORK**

Buggy Axles Put on, Job Complete, up to 1 inch	\$10.00
Buggy Axles, Each, Put on up to 1 in.	3.00
Axles Set, Each	1.25
Four Buggy Tires, Set Hot	8.75
Four Buggy Tires, Set Cold	8.00
Re-setting One Old Tire	.90
Four Buggy Tires New	8.50
New, One Tire	2.50
Buggy Springs Welded, Per Leaf	1.00
Iron Replaced on Shafts	.60
Shaft Iron Welded	.60
Shaft Shackles	Each .60
Shaft Eye	.90
Pole Irons, Replaced	.90
Pole Circle Irons, Replaced	.60
Pole Brace, Welded	.90
Pole Eye	.90
New T Hammer Strap	.90
Axle Clip	.80
Saddle Clips	.30
Steel Bow Socket	.90
One Buggy Single-tree Clevis	.30
One Buggy Single-tree Celvis Bolt	.15
One Buggy Single-tree Ferrules	Each .15
One Buggy Single-tree Cockeye	Each .15
One Buggy Clip King Bolt	1.25
One Buggy Reach, Iron Welded on old Reach	.75
One New Whip Socket put on	.60
One New Top Prop, Put on	.50
One New Prop Nut, Put on	.20
One New Bow Rivet	.15
One New Buggy Spring	\$2.75 to 3.75
One New Buggy Spring Clip, Put on	.40
One New Buggy Shackle Clip, Put on	.75
Buggy Box in New Wheel	Each .80
Buggy Box in Old Wheels	Each .60

**BUGGY WOODWORK**

Shafts, New, with Old Irons, Per Pair	\$ 4.85
Shafts, Ironed and Painted, Complete	5.00
Shafts, Cross Bars, Old Irons	1.55
Shafts, New Express	Each 3.10
Pole Only	4.05
Pole, Ironed and Painted, Complete, No Neck-yoke	8.00
Pole Circles	Each 1.85
Buggy Single-trees	.75
Buggy Double-trees	1.25
Buggy Neck-yokes	1.75
Patent Spokes, Single	Each .40
Patent Spokes, four or more	Each .25
Rims, Set 1/2 and one inch	Each 6.00
Rims, Set over on inch	7.50
1/2 Rim	1.25
One Rim Only	2.15
Axle Bed	1.55
Reach Single	1.40
Reach Pair	2.50
Head Block	1.85

Spring Bar, Plain	1.25
Body Panel Side, one Coat and Priming	8.75
Body Panel End, one Coat and Priming	1.85
Wheels Out Down, Tire Set, Per Set	11.00
Piano Box, One Seat, with Old Irons	12.00
Spring Wagon Box, with two Seats	15.00
Bow Sockets	Each 1.25
Buggy and Surrey Dashes	\$1.85 to 4.85
Buggy Side Curtains	Per Pair 3.10
Surrey Side Curtains	\$6.00 to 7.00
Buggy Boots	\$1.25 to 2.50
Buggy Side Bars	\$1.85 to 2.50
Wood Buggy Bows, Put in	Each 2.15
New Wheel Complete, C. Grade, 1 inch with New Tire, Not Painted	6.00
New Wheel, Set C Grade, 1 inch with New Tire, Not Painted	18.00
New Wheel for 1 1/2 inch, Add Extra Per Set	1.85
New Wheel for 1 1/4 inch Add Extra per set	8.75
Buggy Seat, One New Side	.90
Buggy Seat, One New Back	1.50
Buggy Seat, One New Piece in Seat Frame	Each .90

**PLOW WORK**

Plow Beams, One Horse	\$ 8.10
Plow Beams, Three Horse	4.35
Plow Beams, Two Horse	8.75
Setting Plow Beams	1.50
Plow Rounds	Each .30
Plow Handles, Straight	Each 1.25
Plow Handles, Bent	Each 1.75
New Cultivator Single-tree	Each .40
Polish Plow, Complete	\$1.00 to 2.00
New Land Slide Plate	2.00
New Iron Land Slide	1.25
New Cross Clevis	.40
Plow Evener, Wood	.60
Plow Single-tree, Wood	.50
Sharpen Pulverizer, Per Disc	.30
Pulverizer Tongue	3.10
Four Horse Pulverizer Evener	1.85
Standing Coulter for Breaking Way	1.25
Re-stubbing Riding Plow Axle	1.25
Riding Plow Tongue	2.50
Sharpening Harrow Teeth	Each .08
Take Out and Put in Harrow Teeth	Each .03
Sharpen Seeder Teeth	Each .15
Sharpen Drill Shoes	Each .25
Sharpen Road Grader	Each 4.00
New Lay, 12 inch, Crucible Cast	4.05
New Lay, 14 inch, Crucible Cast	4.65
New Lay, 16 inch, Crucible Cast	5.25
New Lay, 18 inch, Crucible Cast	5.95
New Lister Lay, Crucible Cast	5.25
Add 50c each, net, where soft center are used.	
Point and Sharpen Lay	Each 1.50
Point and Sharpen Lister Lay	Each 1.50
Sharpen Lister Lay	.75
Sharpening 12-16 inch Lay	.75
Sharpening 18-20 inch Lay	.75
New Cultivator Shovels, 4 in Set, Cruc. Cast.	4.00
New Cultivator Shovels, 6 in Set, Cruc. Cast.	5.00
Point and Sharpen Shovels, 4 in Set	3.00
Point and Sharpen Shovels, 6 in Set	4.00
Sharpen Set of 4 Shovels	1.00
Sharpen Set of 6 Shovels	1.50
Land Side Plates	1.85
Land Side Plates	.75
Stalk Cutter Blade	.60

**SLED AND SLEIGH WORK**

Pole Flat Replaced	4.65
Pole Square Replaced	4.65
Roller, Replaced	Per Pair 3.00
Bench Beams	Each 8.75
Reach or Short Tongue	1.25
Bolster	2.75
Runners up to 2x4 inch, Old Irons	Each 8.75
Shoes, New Put on, Steel	Each 2.00
Beams Put in	Each 3.00
Knees Put in	Each 1.25
Raves	Each 1.25
Shoes Cast, Put on	Per Set 8.50
Putting on Cast Shoes, One	1.85
Sled Stakes	Each .80

**MOWER REPAIRS**

Welding Pitman	.90
New Hook on Pitman	.90
Putting Straps on Wooden Pitman	.40
Welding Sickle for Mower	1.00
Welding Sickle for Binder	1.50
Odd Work Per Hour (Stock Extra)	1.00
New Sections	Each .07
Putting Sections on	Each .05
Filing Harvester Sickle	1.00
New Guards	Each .85
Sharpening Guards	Each .05
New Guard Plates	Each .07
Putting Plates on	Each .06
Taking off Guard and Putting back on	Each .06
New Mower Tongue	5.00
Spring Bar, Scrolled	1.85

**"A HORSESHOE FOR LUCK"**

"A horseshoe for luck." Of all prevailing superstitions, that phrase sums up one of the most persistent. War correspondents declare that in many of the trenches they have visited, they have found horseshoes prominently displayed, to ward off evil. Even officers holding important commands have nailed horseshoes over the doors of the houses they occupy. There is a tradition that Nelson had a horseshoe fastened to the mainmast of the Victory, and it is certain that many of the great battle craft of today possess such charms against the menaces to which they are subjected. Many of the battleships of the United States navy have been constructed under the protection of a horseshoe displayed in some prominent place.

St. Dunstan was a tenth century Archbishop of Canterbury, to whom the English attributed the enshrinement of the horseshoe as a symbol of good fortune. For centuries St. Dunstan's day, the nineteenth of May, was celebrated by the blacksmiths and farriers of England in honor of their patron. The smiths organized processions, at the head of which they carried great floral horseshoes. Up to within a century ago there were many women blacksmiths in England. These brawny feminine Vulcans toiled at their forges stripped to the waist, and in a similar state of undress they marched in procession on the day dedicated to St. Dunstan. The French also attribute occult and magic powers to the horseshoe, but with them it is the emblem, not of St. Dunstan, but of St. Eloy, the patron saint of French farriers.

The biography of St. Dunstan, the patron of smiths and farriers, as set forth in monkish legends, is most remarkable and romantic. He was of noble birth and received an excellent education, becoming a young man of brilliant parts. At the court of Athelstan he was for a time a favorite but at length his tricks of "parlor magic," in which he was an adept, resulted in his being driven from court, and great indignities were heaped upon him in the belief that he was a wizard who had sold his soul to the devil. He was madly in love with a fair maiden at the court, and his heart was broken by the enforced separation.

The young man sought refuge with his uncle, Elphege the Bald, Bishop of Winchester, and was induced to enter the service of the church as a monk. Finding that the monastic garb effected no immediate change in his character, Dunstan determined to subject his body to the stern regimen of an anchorite. He set up a forge in a little roadside cell, and toiled early and late. In spite of toil and fasting the old worldly desires tormented him. On one occasion according to the legends, the devil visited him in the form of a beautiful woman, and Dunstan was sorely tempted, but he bore it until his pincers were red hot, when he used the instrument to seize his fair, false visitor by the nose, at which she fled away shrieking with pain. On another occasion the devil, in his proper form, stopped at Dunstan's forge and demanded that the pious smith put a shoe on his cloven hoof. Dunstan made the process very painful and would not release his visitor until satan had promised that he would never enter a house which had a horseshoe nailed over the door. Ever since then the belief has been prevalent that the





horseshoe is a magic charm against the evil one—although such confidence is based on faith in the devil as a gentleman who respects pledges even when wrung from him by torture. It can at least be said that boxers who conceal horseshoes in their gloves are almost universally lucky.

#### Our Friend—The Horse

Notwithstanding the great production of motor-driven vehicles, our good old friend, the horse, and his sometimes calcitrant cousin, the mule, seem to hold their own.

The Rockford Republic, whose editor is something of a statistician, says: "Statistics of the Department of Agriculture show that at the beginning of this year there were 21,166,000 horses on farms, 4,565,000 mules and 3,182,709 horses in the cities, a total of 28,913,709. In 1890, in round numbers, there were 14,000,000 horses on farms in the United States, and in 1900 there were 18,000,000.

"The value of the horses and mules in the country is \$3,032,292,000, while the 1,800,000 automobiles in the country are worth \$1,260,000,000. In other words—and let the automobile dealers take careful note of this—the horses and mules in the United States are worth three times as much as the value of the automobiles.

"If all horses died tomorrow, we should probably starve to death," says the treasurer of the Massachusetts Protective Association for Horses. "We depend upon the horse for what we eat and for what we wear."

"With the friendly horse playing so valuable a part in our economic system, let us all treat this useful animal with kindness and consideration. During the hot summer months especially all persons driving horses should remember that the dumb and patient animal feels the heat just as intensely as its driver."

#### The Smith, An Honest Man is He"

We often hear it said that the blacksmith has it all over other individuals for good old-fashioned honesty. And we say, deservedly so. But here comes a letter from a fellow who says he's going to put us wise. He says that the smith has fewer temptations than men in other trades. That because of the nature of the business he has nothing to resist. No trust funds to stir up his ambitions to see Europe, nothing to adulterate in his line, everything fair and square and above board—with no false weights, nor anything else to deceive the unsuspecting, lamb-like public.

To an extent that's true. But we believe the average blacksmith is honest, well, just because he is. Because he is a real man and it's born in him to be honest. It's a pity there aren't more smiths in Congress and other offices, where honesty is needed today as never before in the history of our country.

#### Bending Brass and Copper Tubing Easily

The following is an easy method of bending brass tubing so that it will not kink or split in the seams: Plug one end of each tube with a piece of soft wood. Place the tubes in an upright position and fill them with hot melted resin. The resin may be heated in a glue pot or a similar utensil. When cool the tubes can be bent to any desired shape. After bending, the resin is removed by holding the tube with the tongs or a rod and applying a blow torch, bunsen burner or other flame. The resin will run out and the tubing will retain its shape.—Ex.



## Benton's Recipe Book

**To Make Varnish Adhere to Metal** seems to puzzle N. R. M. He says, that he does not seem to be able to make the varnish stay in place. Of first importance, of course, is the matter of cleaning the metallic surface thoroughly and carefully. This may be done by washing with a weak solution of soda, preferably applied hot. After the surface has dried thoroughly, add a small percentage of boracic acid to your varnish and then varnish in the ordinary way.

**A Paint for Canvas** is wanted by R. F. B. and is made as follows: Good yellow soap shredded into slices, 2½ lb.; boiling water, 1½ gallons. Dissolve and, whilst hot, grind the mixture up with 1¼ cwt. of good oil paint.

**Coloring Copper** and how it is done is the request of J. F. C. The Recipe Book is filled with items on the subject but one recent addition to the R. B. will perhaps suffice to give this Western reader the information he wants.

Copper lends itself readily to coloring processes and may be worked to all shades imaginable, excepting the lighter shades, which are lost on a copper surface, as that metal cannot be given a tint lighter than its natural colour.

Copper can be carried through the entire range of shades, from a very light copper colour to the darkest brown, or even black, by merely oxidizing the surface of the metal. Make a paste of iron oxide and graphite, with alcohol (wood) or with plain water (the alcohol dries out quicker and allows the process to be hastened), then heat the article in an oven or over a gas flame. The colour obtained will depend on the amount of iron oxide mixed with the graphite, and the length of time the heat was maintained. The more iron oxide in the coating, the darker the shade given to the copper.

The remains of the coating should be removed by a brush or cloth moistened with alcohol, and when the surface has become quite clean, protect the colour by applying varnish, lacquer, or pure wax, which may be laid on with a brush while the copper is heated. Some brown colours are obtained by using a mixture, as above of verdigris, sal-ammoniac, and vinegar, using two to three times as much of the verdigris and sal-ammoniac as of the vinegar. The heat treatment is the same as in the preceding paragraph, and the colour obtained can be made very much darker by adding some blue vitriol to the solution.

A red-brown may be given by using a vinegar paste containing equal parts of verdigris and cinnabar, together with two and a half times as much each of sal-

ammoniac and alum. The heat treatment is the same as for the other coatings.

A wide range of colours, comprising shades from a blue-black to blue-grey, may be given to copper by dipping in a hot "liver of sulphur" solution and then washing thoroughly, re-dipping or scratch-brushing and again dipping and washing, according to the tint desired. This must be learned by experience. Much information can be gained by taking some of the solution and some small pieces of copper and experimenting.

**A Blow Hole Filler** is wanted by H. M. F. who says he has occasional use for something of this kind in his work. A mixture made up of two pounds of powdered sulphur and four pounds of fine graphite makes a good filler for this purpose. When turning the face of a casting the tool frequently breaks through into a hidden blow-hole or other flaw; and although the cavity exposed in this way does not weaken the casting to any appreciable extent, it spoils the appearance of the work and requires it to be discarded. To avoid this, prepare a mixture of sulphur and graphite as suggested above; mix these ingredients thoroughly and put the mixture into an iron kettle; then fuse the mixture by heating it over a slow fire. Care must be taken not to overheat while melting, as sulphur may catch fire if heated rapidly. When the mixture has entirely melted it should be stirred for a few minutes to insure a thorough mixing of the sulphur and graphite, after which it is poured into moulds and allowed to cool. In its solid form the mixture is hard and possesses a dull metallic lustre. When a blow-hole is discovered in a casting, it should first be thoroughly cleaned to remove all grit and dirt, after which a hot soldering iron is used to melt enough of the blow-hole filler to fill the cavity a little more than level. When cool, the surface is smoothed off with a file and emery paper, and will then be scarcely noticeable in the surface of the finished work.

**Silvering Mirrors and Silver-plating** glass is a formula request received so often that the following recent addition to the Recipe Book will prove interesting to many readers of this column:

Two solutions are used. For convenience they may be designated as solution No. 1, and solution No. 2.

Solution No. 1 is prepared as follows: To a one per cent solution of silver nitrate add pure aqua ammonia, drop by drop, till the precipitate is almost all dissolved. Let this stand and then filter. The filtrate is solution No. 1.

To prepare solution No. 2: Dissolve one gram (.04 oz.) of silver nitrate in a little water and add to 500 cubic centimeters (17 fluid oz.) of boiling water. Then dissolve 0.85 gram (13.12 grains) of Rochelle salts in a little water and add to the 500 cubic centimeters of boiling water containing the silver nitrate. Boil for 20 or 30 minutes till the gray precipitate has collected, and filter the solution. This filtrate is solution No. 2.

The glass surface to be coated must be carefully cleaned with alcohol to remove all traces of grease and dirt. All other surfaces which are not to be coated, should be painted with melted paraffin after the glass has been cleaned with alcohol. This leaves a clean exposed surface on one side of the glass to which the silver will stick. In coating with the paraffin, be careful



not to get any on the clean surface. Mix equal parts of solutions No. 1 and No. 2, and place the glass to be coated in the solution. The silver will stick better if the clean exposed surface of the glass is rubbed with a small cotton swab, saturated with the solution. Leave the glass in the solution till the coating of silver is as heavy as desired. Then scrape off the paraffin, being careful not to mar the silver deposit on the rest of the glass. If desired, to protect the silver coating, two thin coats of white shellac may be applied.

**Is Retreading Successful?**

In Reply to a recent query from a reader:

Retreading is generally worth what it costs, that is, if it is done by a good responsible repair-man. So far as double-treading or putting two old tires together is concerned, the best answer in the writer's opinion is that it does not represent a good economic investment. If the same amount of money were to be put to the purchase of a new tire of a good make, it would, nine times out of ten, be much more profitable to the purchaser. Any local repairman will furnish you with any number of reasons why either a good repair or the purchase of a new tire would be much more profitable than to try to combine two old tires and make one new one.

R. R. D.

There are some cases where the double treading of a tire is justifiable; but there are many where it is not.

The double thickness of the tread causes an enormous amount of heat to be generated due to the increase of internal friction. This has a deteriorating effect on the rubber and causes ply separation.

It is a well known fact that there is as much wear on the inside of a tire, due to friction, as there is on the outside. This inside wear is materially increased because of the extra thickness of tread and after a double tread tire has run a few hundred miles, fabric breaks will appear on the inside of the casing and cause tube pinching. A tube pinch always means a blow-out and endless tire troubles.

Experiments have proven that a double tread tire will increase the gasoline consumption of a car by about 10%. Gasoline consumption is a point that is overlooked by a great many people while it should be of vital importance. The type and make of a tire that is on a car has a great deal to do with it and the writer believes that a good many dollars could be saved in fuel consumption if automobile owners would pay more attention to their tire equipment.

O. A. H.

An engineer does not depend upon the strength of materials alone, to make a safe railroad bridge or building—it is necessary that the structure also be designed along the right principles.

A successful tire must be properly designed, i. e., the shape suitable for the size of the section and a correct balance is an essential thing; the tire must be strong enough to render good service but not too thick, heavy or stiff to prevent distribution of strains and stand the flexing action in side walls.

Extra thicknesses and weights added to tires will cause additional heat and interfere with the radiation. Tread attachments or covers creep, craze, heat and stiffen the tread to such an extent that fabric breaks are caused by a localized hinging action in side walls.

It is not advisable to use reliners in new tires because they tend to flatten the tires similar to under-inflation and, in many ways, interfere with the design and intended action. If made of flexible material, and well-constructed, reliners, are a good thing in old tires having separation and breaks in the fabric and which would not, without reinforcement, be serviceable. Under such circumstances, reliners strengthen the tires, protect inner tubes from being pinched by the fabric and often make it possible to secure a great deal of mileage.

L. G.

If by double treading is meant the sewing on of an additional tread over an original tread, we do not recommend it.

We have found that the most successful and practical way to handle tire repairing, is to tear out all of the old rubber and fabric, and replace it with new, vulcanizing the whole.

H. T. E.



**Queries—Answers—Notes**

**PLUG SMALL HOLES**

That is the Way to Avoid Excessive Trouble

The proper care of the tread is one of the important elements in tire conservation which we are trying to impress on motorists," says a tire expert.

The tread of a tire is one of its most important parts. Its purpose is to protect the carcass from the wear and tear of road travel and from deteriorating influences, such as moisture and dirt. If it becomes cut or torn the tread does not have a fair chance to protect the carcass.

Ordinary tread cuts are noticed and vulcanized by many motorists; but the little cuts, caused by nails, broken glass, etc., these are the ones which cause so much trouble.

These little cuts pick up dirt and moisture, which work into the cotton fabric.

The union between the rubber of the tread and the fabric of the carcass is soon destroyed. Sometimes a tread that has been cut badly on stony roads will separate all the way around the tire as the result of a single rainy day's driving.

**Drawing Plow Lays**—Will some reader please tell me how to draw plow lays to make speed? Also how to hit from the edge to draw them fast and how to pull my hammer.

It seems that I do not draw them out evenly, and draw too slowly when they are thick.

J. T. SMILEY, Oklahoma.

**Information on Making Spurs**—In your December issue I saw an inquiry about

different ways of making "spurs."

I will give a very easy method which I used in making some for myself.

I took a piece of steel tire 1 inch, by 3-16 in. split it far enough for the heel band, cut off about 2 inches longer on the solid part, folded the solid part over a piece of iron about the thickness I was to make the spur wheel, this turning the split ends flat sides together, then I spread these out and finished them. Next I shaped the shank as I wanted it, then I put two hacksaw blades in the frame tight together and sawed down the top side of the shank far enough for the wheel which I riveted in. I drilled the wings and threaded in some short, oval head rivets for the strap buttons. I finished all parts smooth with emery cloth before assembling, and after assembling blued the whole at the fire. This makes a neat looking plain spur. I have made several port bits of my own original, designed cheeks and other articles by way of recreation in slack times during the thirteen years I have been in business as blacksmith. I have taken The American Blacksmith ever since I started repairing wheels fifteen years ago and I have every copy to date laid away for reference. I have taken other trade papers in the meantime but dropped them after a few years, for this is the "Best" paper I think for our trades people.

GEO. BRYANT, Vermont.

I am writing you for information on forge building. I use a round forge 4 1-2 feet in diameter. I use a 3 inch double strength pipe through the center of the forge with direct connection to a 16 inch blower. Some few weeks ago, I tore my forge down to the bottom of the pipe, for the purpose of putting in a new pipe. The old one was burnt in two. I then built my forge back with Portland Cement and sand, but it cracked loose from the old cement and the new cement is blowing out, and I am losing a lot of draft. I have plenty of fine clay and cement. Please tell me which is best to use, and how to mix it to get good results. I run a heavy fire, and it is giving me lots of trouble, as it is now.

L. P. RODREES, Texas.

**In Reply**—We would suggest as a remedy that you use both a good quality of cement and that you line this with a thick layer of fire clay. We judge from what you say that you have been using cement alone without the protecting layer of fire clay.

It is also very necessary that the portion of your forge built up of cement be allowed to set thoroughly, and then that you apply heat gradually in drying it out. This must be done very gradually. The same precautions are necessary in lining your fire pot with fire clay. Use as little moisture as necessary in getting the fire clay into position in the fire pot, pounding it hard into place, and allow it to set and to dry out thoroughly before attempting to use the forge.

I have had many pleasant hours reading "Our Journal" and have been more than pleased with many of the items in them. I read all from cover to cover and in this far off little town find many helpful items especially in motor work. I have had many repairs on the springs and have, more than once, helped to take a car to pieces and put in new parts. One car, a Ford, that I have repaired, makes a noise in the gears, and do what we will





wash them first in water, then in concentrated lime water till all trace of the acid has disappeared. When dry they will have the appearance and cutting quality of new files.

S. S., New York.

I will tell you how I dress and temper old rasps that have been worn out. First, I heat the rasp and draw the temper. Then with a three-cornered file I dress the teeth sharp, the same as in the case of a saw. When I have the teeth sharp, I heat again and coat with a cyanide of potassium, plunge in water till cool and it will be as good as new.

J. F. LOHR, Ohio.



## The Automobile Repairman

### Motor Knocks

How to Locate and Remedy Some of the More Important Ones

J. N. BAGLEY

One of the most annoying things to the motorist or repair man, is a knock some place about the engine or the chassis which he cannot locate. It may be some little thing that does not effect the running of the car in particular, but at the same time it gets on the driver's nerves and the more the car runs, the more pronounced it seems to be. The knock in many instances is one of the hardest things for a repair man to locate. This is due to several things; the parts that usually develop a knocking are concealed where they cannot ordinarily be seen and the metal parts conduct the sound in such a manner that the knock may seem some little distance from where it really is.

Those who have driven the old two-cylinder cars and have experienced the connecting rods coming through the crank case have a horror for a motor knock. I can remember very distinctly a few years ago seeing a neighbor by the road side with his old two-cylinder and a rod hanging through the case. I came upon him suddenly from behind and

noticed him standing beside the car with something in his hands. As I approached him I remarked rather suddenly, "Had some trouble, Bill?" "Trouble thunder," he remarked, "I was just counting my cash to see if I had enough to have that car fixed again; had a rod come down again and it only knocked a little. This makes the third one in two months and I want to have it fixed without letting my wife know what has happened; for she told me the last time I should not spend a single cent on it if that rod came down again." I looked under the car and saw the rod sticking through the bottom of the case and half of the triggers next to it were either bent or broken. I asked him why he didn't stop when he heard it knocking and he said that he thought it didn't amount to much, as it wasn't knocking very hard.

A knock is dangerous and should not be allowed to go a minute longer than can be helped for one cannot tell just when a knocking rod or something or other will give way to the strain, and ruin some parts of the motor. Usually this means a very expensive repair, and the part repaired will not be the same as before.

The connecting rod knock is probably the most dangerous knock of all. When a rod becomes loosed sufficiently to knock it grows worse very rapidly, for a little slack in the bearing allows the weight of the piston to give it a jerk on both the upward and downward stroke; and the metal of which the bearing is made, is thrashed out of the rod. When this bearing metal is gone the slack is such that the bolts holding the cap are soon jerked loose and the work is finished..

Each and every knock which is liable to develop about the motor has a distinct knock all its own and can be located readily by an experienced man. There are but two knocks having a close resemblance and that is the carbon knock and the loose wrist pin, while either of these are not particularly dangerous, they should not be allowed to remain without attention. The knock caused by the carbon deposit on the piston is due to the piston becoming heated to such an extent that it will ignite the charge independent of the spark, and as this takes place while the piston is still on the upward sweep it brings a sudden strain on the shaft, as the flywheel forces the crank to turn against the pressure of

the ignited charge. An advanced spark will many times have a similar result on the motor. The loose or worn wrist pin will not give any particular trouble like the loose connecting rod, but it should be repaired at once, for there is the annoying tap, and each tap wears the piston bearing a little more oblong. There are cases where the piston has been jerked into two parts on account of a loose wrist pin.

The connecting rod knock comes at intervals whether the motor is running free or not. When the motor is pulling the load it sounds the same as when running idle, except that it is somewhat louder, as it is then driven down with the force of the explosion and jerked back very quickly, giving a knock at both top and bottom of the stroke.

The main bearing knock is a deep, heavy knock as compared with the connecting rod knock; and unless the bearing is very loose, it will only develop when the motor is "drifting" at high speed. By drifting, we mean speeding the motor up to say, 30 miles to the hour, suddenly shutting off the gas with the clutch engaged and letting the momentum of the car drive the engine. The main bearing knock is not considered as dangerous as the connecting rod knock, but nevertheless it should be cared for as soon as it is discovered.

Then we have another knock known as the fly-wheel knock, which is a very heavy ugly knock, somewhat resembling the main bearing knock, except that it comes at every revolution of the crank and is noticeable on a hard pull with the motor laboring slow. It sounds a good deal like a heavy hammer at work in the motor. This should not be allowed to knock for it is very dangerous as it effects the motor by the jerky action which it has between knocks. In case a fly-wheel is allowed to run loose for any length of time, it is next to impossible to keep it tight thereafter, for it is usually machined to fit very tight to the shaft, and a little wear will leave them very loose.

A knock in the rear of the car is another that is usually difficult to locate because of the sound being transmitted over the metal chassis. This is usually caused by some particle of metal getting into one of the teeth of the master gear, or bevel gear as some call it; each revolution of the drive pinion passing over it and causing this



sound. It can be corrected by taking out the little filler plug in the housing and turning the gear slowly and feeling into the bottom of each of the teeth with some metal instrument. When the particle is found, place a bunch of waste below it and with the aid of a magnet push it from its setting and pick it out with the magnet.

We have still another knock which develops in the push rods that lift the valves. Most up to date cars have an adjusting device on either the valves or the push rods and in case this adjusting device works loose, it leaves a little slack between the two and as the cam revolves against the push rod, it is rapidly pushed up against the valve. When the connection is made the knock is heard. This can be remedied by making the adjustment, allowing only a very small space between the two, say the thickness of a thick sheet of paper, if the motor is cold, and if it is hot possibly a thin sheet of paper. In case a thickness gauge is at hand it can be used very well by taking about .0005 of an inch and spacing all of them by the gauge.

Then we have the cam-gear knock which has much the same sound as the loose tappets just mentioned, except that the knocks seem to be much faster. The looseness in the teeth allow the valve springs to slap the cam shaft back and forth as it is resolved. There is but one remedy for a knock of this kind, and that is to remove the old gears and replace with new.

A badly worn universal joint will cause a knock, allowing the joint to revolve as if out of balance, or the bearings on either side of it will make a knock sounding much the same. In either instance there is nothing that can be done to prevent it, except to replace with new at once.

A broken bearing in the transmission will cause a knock each time the shaft revolves, and is also hard to locate because of the sound being transmitted by the metal surrounding it.

The best advice that can be given is to have the knock located and repaired as soon as it is noticed. Otherwise it may prove a very expensive proposition if allowed to run. Not long ago a customer came to the shop with his car knocking, as the result of a loose rod, and wanted to know what was causing it. I explained to him what it was and he wanted to

know if he couldn't drive it back home and bring it back the next day, as he was very busy. I told him of the danger of running the car in such condition, but he said he would risk it. He did to his sorrow. About thirty minutes after he had left the shop, he was towed back and the cost of the repair was \$32.00 whereas if he had had it repaired at the time of discovering the knock it

current ground was made at this bearing, the vibration at high speed caused the timer body to wobble slightly and contact was not always positive. Inasmuch as the wear was too slight to warrant rebushing, a positive primary ground was made by running a short copper wire from the screw on the timer body to one holding down the name plate on the body of the motor-generator. If



MR. E. J. CLAPP'S UP-TO-DATE SHOP IN IOWA. HE IS DOING A NICE BUSINESS HANDLING GASOLINE AND AUTO OILS ALONG WITH HIS SMITHING

would have cost no more than possibly \$2.00. Delays are dangerous wherever knocks are present. Repair them!

## Curing Engine Misfiring at High Speeds

VICTOR W. PAGE

A very unusual cause of irregular engine operation at high speed was recently brought to the attention of the writer. The engine was a four cylinder type equipped with uni-coil battery ignition, the igniter or time-distributor being carried by the motor-generator as illustrated. The "skip" did not materialize until the car had been operated nearly 10,000 miles and it was impossible to eliminate it, even after a new carburetor, new spark plugs, new wiring and a new distributor head were fitted. The repairmen and other motor wise individuals called into consultation by the car owner could offer no remedies other than had been tried. A factory expert from the ignition apparatus maker was called and in five minutes, the "skip" was eliminated and the engine was purring at all speeds. The trouble was due to wear in the supporting bushing of the igniter and as the primary

anyone is inclined to try this remedy for a similar trouble, they should be cautioned against grounding the insulated primary terminal normally connected to the ignition coil. The same result could be accomplished by stretching a brass spring from the timer body to any fixed part of the generator. This would permit of igniter oscillation for advancing the spark and at the same time would keep it pressed against the supporting member despite vibration.

## Another Advance in Steel

As this issue goes to press, we observe that controlling interests have ordered an advance in certain iron and steel products, notable in wire. The latest reports show an advance of \$4 a ton above present prices in all wire products. This affects in particular the prices of fencing material and nails.

Wire nails are now the highest since 1899 and other products are at the highest points in 25 years.

The advance was prompted by large sales on domestic and foreign account, in conjunction with a heavy reduction in output, due to scarcity of labor and difficulty in shipping.



# TIMELY TALKS WITH OUR SUBSCRIBERS

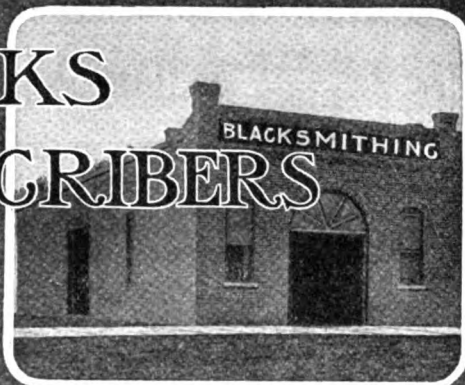

The American Blacksmith is published monthly at The New Sidway Building, Buffalo, N. Y., U. S. A., by The American Blacksmith Company, Incorporated under New York State Laws. Entered, February 12, 1902, as second-class mail matter at Buffalo, N. Y., Act of Congress, March 3, 1879.

William F. Wendt, President

Albert W. Bayard, Secretary

Walter O. Bernhardt, Editor

Associates: James Cran

Bert Hillyer

A. C. Gough

Dr. Jack Deiter

Subscription Price: \$1.00 per year in advance, prepaid to any postoffice in United States or Mexico. To Canada, \$1.25; other countries, 6 shillings. Reduced rates to clubs of five or more on application. See "Honor Roll" page for money-saving, long-time rates. Cable address, "Blacksmith," Buffalo. Lieber's Code used.

Subscribers should notify us promptly of non-receipt of paper or change of address. In the latter case it is necessary that you give us both the old and the new address.

## The Coming Shop Number

A yearly feature of the American Blacksmith, which our readers always look forward to with keen interest, is the Shop Number. In this issue we describe and picture practical plans for shop arrangement, particularly along lines best adapted to equipping with power machinery.

The modern smith is finding both his salvation and his opportunity in branches of mechanics somewhat new to him. He is preparing himself to take advantage of the automobile repair trade of his section, to handle a variety of wood-working, such as body-building and other new vehicle work; he is carrying his old-time methods of welding and working metals by hand into the thorough, speedy and efficient way by machinery, which means equipping the shop with the oxy-acetylene welding apparatus, various machine tools and devices.

We want to know what others have already done—what our readers are doing now to take advantage of these big profit-bringing opportunities. We want to hear from you. We want you to send us pictures of good shops, pictures of well-equipped shops, pictures of well-built shops, pictures of novel, or unusual shops, pictures of interesting shops. Then we want floor plans, descriptions of shop equipment, layouts of machinery, etc; in fact, anything which you think will help to make this number a big, thoroughly practical and useful issue for every brother member of the craft.

### Subscription Agents

When a stranger solicits your subscription to THE AMERICAN BLACKSMITH or any other publication, insist upon him showing you absolute proof that he is an agent in good standing and is employed by the publication which he represents. Don't under any circumstances, give the man your money if you are not sure that he really works for the paper he says he does. No matter what the man offers you—no matter what price he makes—no matter what premium he promises to send—Don't Give Him Your Money If You Are Not Sure.

## Contents, April—1917

<b>"Better Get Aboard Today!"</b>	
Frontispiece .....	158
Using Common "Sense" Methods in Curing Auto Troubles .....	159
Salvaging a Wrecked Automobile...	161
How the Motor Truck is Aiding the Farmer and Blacksmith .....	163
The Care of Tires .....	163
The Fable of the Successful Shop Owner .....	166
Shoeing the Horse for Dropped Sole .....	167
Something about Uncle Sam's Blacksmiths .....	168
The Smith in the Daily News .....	169
United States Navy Needs Blacksmiths .....	169
Blacksmith Indicted for Selling Liquor .....	169
California Shoers Raise Prices.....	169
War Prompts Suicide of Blacksmith	169
Smith Shop and Equipment Stolen	169
Blacksmith Invents New Kind of Bolt .....	169
Dayton Will Operate Municipal Shop .....	169
Forges Cross for Kaiser .....	169
Why is a Ford? (verse).....	170
Heats, Sparks, Welds .....	170
Our Honor Roll .....	171
The Machine and Tool Smith .....	172
Fundamentals of Lathe Practice.....	172
The Oxy-Acetylene Plant—2.....	174
Tire Vulcanizing Now Taught in Public Schools .....	176
Smithing Prices and the Nebraska Organization .....	177
How to Hammer Circular Saws.....	178
Blacksmith a Jolly Dog .....	179
A Noiseless Anvil .....	179
Benton's Recipe Book .....	179
Another Way to make an Old File Cut .....	179
To Keep Oil Stones Sharp.....	179
Proper Lubricants for Machine Work	179
A Recipe for Whitewash .....	179
To Cure Squeaking Springs .....	179
To Remove Paint From Wood .....	179
How to Turn Aluminum .....	179
Queries, Answers, Notes .....	180
To Stop a Forging Horse.....	180
Hardens High Speed Steel Tools in Water .....	180
Now Has Complete Power Equipment .....	180
Tells How to Draw the Temper in Small Taps and Reamers .....	180
Wants to Know How to Harden Motor Vehicle Springs .....	180
A Progressive New Zealand Shop.	180
Welding a Plow Point .....	180
The Automobile Repairman .....	181
Gas Engine Operation Made Simple—7	181

## The Auto and its Opportunity for the Blacksmith

Each year brings to light some new development in the Automobile. When one reviews its evolution, and the rapid strides both the pleasure car and the auto truck have made toward perfection, its brief history is nothing short of astonishing.

The automobile has come to stay. The wide-awake smith who is anxious to make the most of his craft knowledge is including automobile repairing. Those who are already engaged in this comparatively new line of work realize that the automobile offers a remarkably broad field for profits and development.

The blacksmith, as a craftsman of the metal working art, and the recognized repairman of the community, is the logical man to take up auto repairing. It is therefore to his interest and welfare that he becomes fully informed on all phases of automobile repair, operation and the principles of the gasoline engine.

For several years back, we have devoted space to the presentation of and discussion of automobile topics and problems. We have endeavored to secure articles of practical worth to the auto-smith, and shall continue to do so; not merely keeping abreast of the times, but making it a point to always keep a step in advance, that our readers may be informed as to the latest developments, the newest kinks, etc.

This issue is our special annual Auto Number. In it you will find several articles which we believe will prove of great value to our readers. Mr. C. L. White, one of our new contributors, has sent in a description of a unique method of detecting and locating auto troubles. We do not recall having read or heard of such a method before—at any rate, not as completely worked out as this. Mr. White is an automobile engineer who has been connected with the Automobile industry since 1900 and his experience has been of a broad and thorough nature, which leads us to believe that what he says will be worth a lot to us. His article in this issue is the first of a series, and we hope to hear from him frequently in the future.

A new series of articles on the care of tires begins in this number. Their authority is unquestionable, as they have been prepared by one of the best-known authorities on tires in the country. We are greatly indebted to the Firestone Tire and Rubber Company of Akron, Ohio for their kind permission to use them.

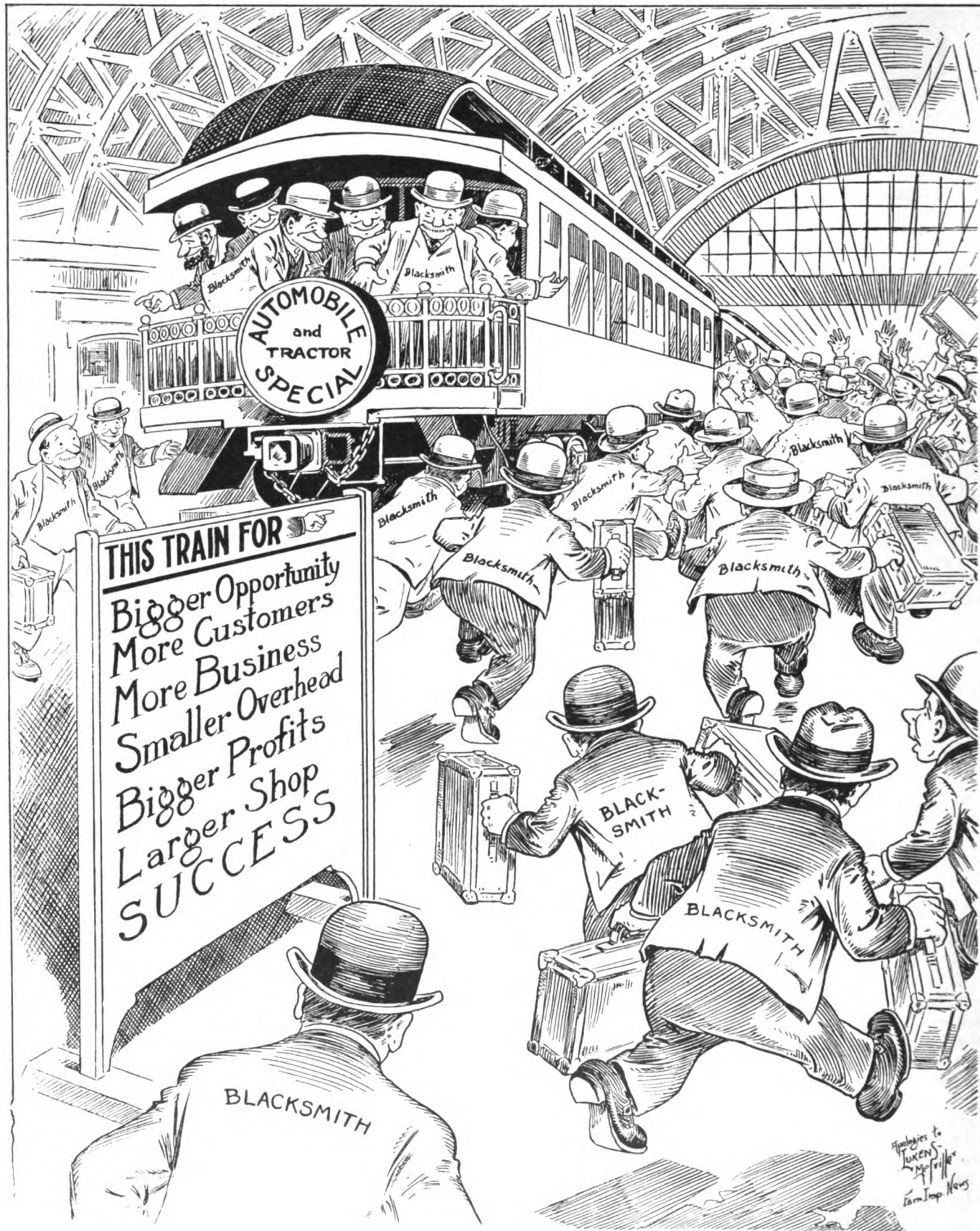

**BETTER GET ABOARD TODAY!**

The Train of Progress waits for no man. It's the fellow with the Push and the Far-seeing Eye who is right on Time when the A. & T. Special leaves for Successville. He's the Chap who "Gets there" early.

He is doing business and stowing away the Shining Iron Men while his less progressive Brothers are still arguing whether the Train will even move or not.



# Using Common "Sense" Methods in Curing Auto Troubles\*

A Practical System, by Which the Automobile Repairman  
Detects and Locates Auto Troubles by the Senses—  
Sight, Hearing, Smell and Touch

C. L. WHITE

**T**HESE methods of detecting and locating automobile troubles, as suggested by the title, have been taught by the writer for several years, covering some nine hundred lectures on all phases of the operation, care, repair, and principles of the gasoline motor car.

Personal contact with automobile mechanics and repairmen, of both the professional and amateur class (including a few so-called "experts"), has revealed an astonishing degree of ignorance and weakness in their methods of diagnosing common, everyday auto troubles. Of course there are a fair percentage who really know their business from A to Z, but in these days of enlightenment, it's a shame that there isn't a larger number.

No doubt the majority are sincere with themselves, and actually believe that they are following correct methods; but the way some of them beat around the bush, trying and monkeying with everything on the car except the part that's busted, would cause their discharge from such a profession as medicine, were they connected with it.

It seems the rule, rather than the exception, that in diagnosing that disease known as "auto-troubilitis", either pure guess-work methods are employed, or else the repairman simply does not use his senses. Instead of relying upon those senses of sight, hearing, smell, and touch, with which an all-wise Nature has provided him, he depends almost wholly upon a few half-digested rules, believing that that is all that is necessary. To an extent, one can depend upon such rules and charts. But doesn't it seem that the automobile repairman will be far more efficient if he can "sense" troubles *even before they appear* in the shape of some serious breakdown, and to

locate them quickly and *accurately* when they do make themselves in evidence?—much after the manner that the practical horseman learns to know his beasts.

Such is the purpose of this article: to outline in more or less of a tabulated form, a practical guide for the training of the senses for detecting and locating automobile troubles.

It is important to keep in mind that it is not enough to merely read over an outline of our method—it is vital that one put its principles

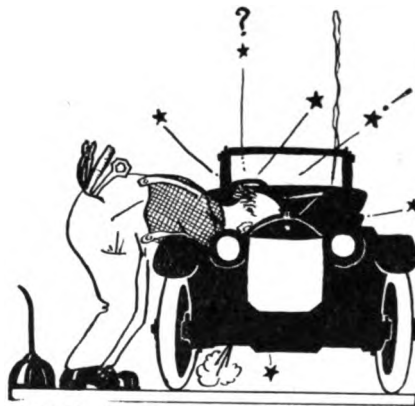

NO NEED TO TAKE THE INSIDES  
OUT TO FIND A  
MISSING CYLINDER

into practical use at every possible opportunity. One cannot train the senses to respond instantly and with precision over night; it is a matter of consistent and constant development. One should train himself, so that eventually the sensing of any motor car trouble and locating its whereabouts without any delay or circumlocution, becomes sub-conscious. That is, automatic; without the necessity of having to carefully think over all the possible troubles that could occur, and then choosing one that *might* be the cause of the particular disturbance at hand.

A symptom appears, and at once you know what is wrong and exactly

where the trouble is located. You literally have your hands upon the pulse of the motor car. You bear the same relation to the automobile, that the physician does to the human patient. You diagnose the case, determine in your own mind the proper form of treatment, prescribe remedies, and operate if necessary. And because you are an expert, and *know*, and save your own time and that of your customer, you are justified in charging for your services as does the practicing physician—or lawyer, for his advice, which may save many dollars. Get the point! —a car runs (or it towed) into your shop with inflammation of the radiator, a cold in its carburetor, a severed nerve leading from its storage batteries, or carbon on its chest; and you—Dr. Repairman, immediately feel its pulse, listen to the working of its internal organs, feel around for any broken "bones", advise as to treatment, or fix it up—and send in a bill that would amount to, we'll say—\$5.00 an hour!

The necessity for training these very important senses, is clearly recognized in many lines. Can you imagine what would happen if the pilot of a giant vessel failed to use his senses at a critical moment? Or the driver of a locomotive controlling the destiny of hundreds of passengers? Or a surgeon operating upon a patient, where the tiniest slip of a knife might mean instant death? Perhaps these examples illustrate our point a bit forcibly for the subject under discussion. But nevertheless, you cannot fail to realize the necessity, and the practical money-value of this training, from the following illustrations of what happens when one does fail to use his senses.

We'll say for instance, that a car has been brought into your shop for overhauling. Any one of several things might happen as the result

\* Copyrighted 1917 by C. L. White. All rights reserved.





of some oversight that could easily have been prevented: failure to see a missing cotter pin—a front wheel dropped off while driving at high speed—car ditched, and merely a few broken ribs and other parts of the driver's anatomy missing. Things "happen mighty sudden" when there's anything wrong with the steering gear connections! A leaky pipe—failure to see, or smell the "gas"—and another car gone up in smoke. A burned-out bearing, due to lack of oil, which could have been noticed in time by the smell. A knocking—a loosened connecting-rod bearing—and a demolished engine base.

And we could go on, reciting any number of instances with which both you and I are familiar.

Before we go into detail with an outline of our method, a few suggestions with reference to training the senses especially for locating and detecting automobile troubles, will doubtless prove of value.

1—Stand at the intersection of some road or street where the pavement is sufficiently smooth, so that the operation of cars under power can be heard. Listen intently to the noise made by the engine, transmission, rear axle, exhaust, etc. Try to actually locate these noises as the car passes. Ask yourself, "Does the engine knock? How does the transmission sound in the different gears? Can the rear axle gears be heard? Does the exhaust sound as though the engine were pulling evenly? Are the brakes dragging? Can you see any loose parts, wobbly wheels, or smoke? Can you smell any unburnt gasoline in the exhaust?"

2—Practice this at a point where the road is rough, so that you can hear all the rattles and try to locate them.

3—In the shop, make a thorough inspection of the entire car and train yourself to see things that are

out of place, loose, broken or worn.

4—Learn to feel the vibration of the engine when the car is standing, by placing the hand on different parts of the chassis. When driving the car yourself, consciously feel the vibration at the wheel, pedals or seat.

A small amount of practice will make these senses surprisingly acute and you will soon be using them subconsciously to locate automobile troubles. People will wonder "how you do it."

One warning only need be given here, and that to those endowed with active imaginations: learn to discriminate, or you may soon be "hearing things" that are not. Do not aggravate this "sense" by over-indulgence.

Then there are a few points to be kept in mind as we analyze the diseases of the car we are inspecting, the most common causes of auto troubles, an outline of which follows taking them up in order of their importance:

1—Inexperience or careless driving.

2—Car not properly lubricated, (which generally means, not regularly lubricated.)

3—Car not regularly inspected for loose parts by a competent repairman, or a self-trained, careful and thorough owner.

4—Inexperienced or careless repair work, which always means trouble later.

5—Unavoidable accidents, such as collisions.

6—Structural defects, the fault of the designer or manufacturer.

The first three are largely up to the owner who drives his own car, and are most frequently the cause of auto troubles. Yet the fourth is of far too frequent occurrence when one considers all the expert technical knowledge available today.

And now we come to the first method of diagnosing automobile troubles by the "sense" method—that of troubles we see. The other methods, which comprise hearing, smelling, and feeling will be, fully treated in subsequent articles. Until then, make it a point to cultivate to the fullest, the sense of sight in detecting and locating auto troubles.

Many will say at the start, "I can see for myself. Why enumerate these troubles?" And you are quite right—up to a certain point. But just put this under your hat—unless you have so cultivated and trained this sense of sight in connection with diagnosing automobile troubles, so that the detection and



FOLLOW YOUR NOSE AND YOU'LL NOT GO WRONG

location of these troubles is subconscious, the chances are that you do not really think in determining whether a thing is O. K. or not.

Think for a moment; do you always see the thing you look at? After long years of experience with men who desired to become competent automobile mechanics, I find that perhaps the most frequent excuse for a mistake is, "I didn't see it!" In other words, the car was looked over—and the trouble overlooked.

Now for the real work. We say work, because the acquirement of this accomplishment of finding the exact seat of a trouble quickly and positively every time, is real work. It demands thinking and practice.

Take the next car that comes into your shop. Look it over slowly and carefully, keeping in mind some of the common causes of auto trouble as outlined above. Then go over the following list of troubles we see, and examine every part of the engine chassis to determine what and where these principles of trouble-finding apply.

First look for loose parts, bolts, screws, nuts, cotter pins missing, etc. Give particular attention to the steering apparatus, testing all gear connections and all spring clip-nuts, axle-holding bolts, etc. Look over the engine in a similar fashion, keeping your eyes open for and missing screws, nuts, bolts, etc., and testing with a screw driver and wrench for those that are loose.

Particular attention should be paid to broken or loose wires as they easily escape observation. Follow each wire with the hand and test its condition and observe its connections. Note if there appears to be any internal breaks, and whether connecting terminals are loose.

Oil leaks, or insufficient oil to engine are frequent sources of trouble,

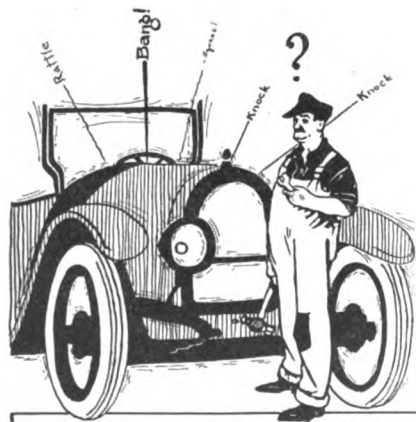

HARK TO THE "RING" OF THE PISTON



and if allowed to go long enough, bearings are apt to become burned out. If you are not familiar with the particular oiling system of any car you may be overhauling, write to the manufacturer for his instruction book and find out for yourself whether sufficient oil is provided where necessary.

*Fan belt loose, or broken, or leaky radiator* causes overheating. This will usually be noticed by observing steam escaping, either from the filler-cap, if the cap does not fit tightly, or from the bottom of the radiator at the overflow pipe. Don't mistake the water running or dripping from the overflow for a leak. Other causes of radiator overheating are a kink in the hose, dirt in the water passages, or a frozen radiator in cold weather. In the case of a leaky radiator, where the leak is small, you can safely use some of the compounds on the market which are quite effective. A handful of corn meal will serve well as a temporary repair for emergencies, if put direct into the water. Of course these are only temporary repairs; permanent results should be guaranteed by soldering.

*Gasolene leaks* would seem easy to detect, by the odor if not the sight. But as a matter of fact, motorists become so used to the smell of gas that they do not always note any special leak from what their noses tell them. Hence it is wise to look around carefully for little leaks as for instance at pipe joints—especially those tiny ones that never show any drip under the car. Inspect and feel every joint. Gas leaks are dangerous and one cannot give too careful attention to them.

*Storage batteries* demand special attention. We could enumerate many cases where the plates were completely destroyed by allowing the electrolyte to become low. So many cars are now equipped with storage batteries that the importance of keeping the "acid" at the correct level needs to be emphasized. The best way to test this level is by means of a small ( $\frac{1}{4}$  inch) diameter glass tube, about six inches long. Put this tube down into the cell until it hits the top of the plates, place finger over top of tube and carefully remove the tube. A certain amount of liquid will remain in the tube and its height indicates the level of the acid in the cell above the plates. This level should be kept at about  $\frac{1}{2}$  inch above plates, but not more unless for special batteries. If it is less, add distilled water—not common water or acid. If the level

of the electrolyte (acid) quickly lowers, there is probably a leak and you should inspect the battery box for such. If the level gets too low, and remains that way for any considerable length of time, "sulphation" takes place—that disintegration of the plates resulting, perhaps in the worst "disease" that can befall a storage battery. You should advise your customers to have their batteries inspected regularly every two weeks.

If the car is equipped with a battery indicator or ammeter, see that this shows "charge" when the engine is driving car faster than 10 or 12 miles per hour. In case it does *not* show "charge," look over the generator and battery wires and then if necessary, have generator tested by a competent automobile electrician.

*Smoke from exhaust* usually indicates too much oil in engine, if it is of a bluish-white nature. In this case drain off some of the surplus oil or reduce the feed. This depends upon the car: either drain off from the oil reservoir or crank-case. Black smoke is caused by too much gasolene in the mixture. The remedy is to re-adjust the carburetor.

*Car listing to one side* may be caused by a broken spring, or perhaps the spring is sagging. In which case the trouble should receive immediate attention. A flat tire causes about the same listing as a sagging spring.

*Lights out, or fail to operate.* The cause can be traced to wires, batteries, or switches if electricity is used; if acetylene, the tank may have been discharged.

*Wheels out of alignment* may be tested accurately enough for all purposes by drawing a taut string from the front wheels to the rear, below the hub caps and along outside the tires, parallel with the ground. (The tires must of course be of the same size to measure accurately with this method). By sighting along from the front to the rear wheels to see that all wheels are "straight ahead" is also serviceable. Some make this test by measuring the distance between the front and rear sides of the front wheels.

As accidents and driving over rough roads sometimes throw the front wheels "out", and also damage the spokes, the spokes should be carefully inspected for signs of straining, such as splitting and other defects.

*Tire troubles* always demand careful attention, as most of those which

later prove serious could easily be avoided by inspection in time. Watch out for flat, badly worn, rim cut, scraped tires, and tires with small holes and slits—the kind that pick up water, grease, sharp stones, etc. which gradually work into the tire fabric and eventually bring about serious blow-outs.

So much for *troubles that we see*. We have not attempted in this brief treatment of the subject, to outline in minute detail all the miscellaneous array of motor car troubles that could be seen. We have been contented with pointing out the most serious ones, and many of those that are commonly overlooked. A complete volume could be written on the subject, but our main object is to encourage the practical repairman to use his senses to the fullest, to develop and train them so that nothing escapes him—and not to tell him how to repair a car. There are plenty of books on the market for that.

By carefully studying the principles outlined in the foregoing and putting them into practical operation, you should be able to develop your *powers of observation* rapidly, so that they will serve you to splendid advantage.

It is necessary that you, as a repairman, should know how to repair a car. It is far more necessary that you be able to correctly diagnose motor car troubles, and KNOW what remedy to prescribe. It will save you time and unnecessary puttering, it will enable you to go direct to the seat of the trouble; it will give you something that will command the respect of others and in particular those with whom you have business dealings as far as repairing and overhauling goes, and that may be embraced in the simple statement: "He knows his business."

(To be continued)

## Salvaging a Wrecked Automobile

One look at the accompanying picture conclusively proves that no matter how popular a Ford may be, it was not made to dispute the right of way with a locomotive.

This one had been on the road only a short time—probably not more than a dozen trips, and in its youthful enthusiasm, thought it could beat a fast freight bearing down on the boulevard along which said Ford was merrily traveling. The hand of Fate, however, choked the carburetor, or something happened, and the locomotive and diminutive automo-

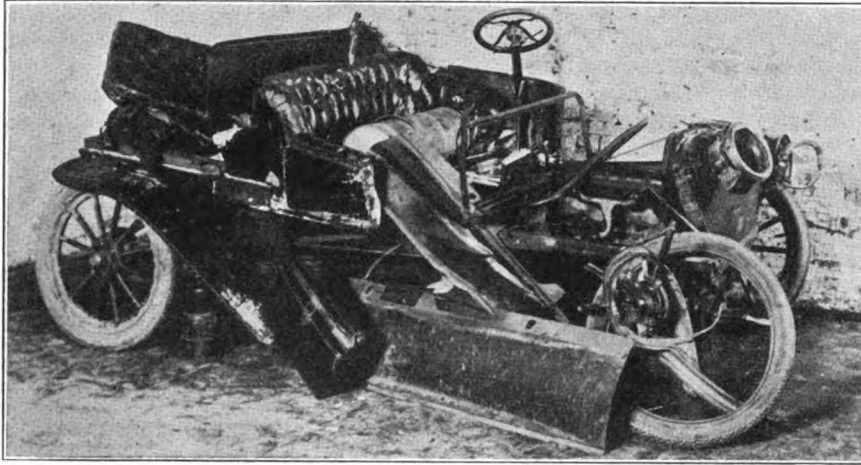

EVEN A FORD WAS NOT BUILT TO DISPUTE THE RIGHT OF WAY WITH  
A LOCOMOTIVE

bile came together at exactly the same point. Result—the picture tells the story.

We happened to hear about the accident, and according to our custom to be on the lookout for bargains in automobiles, we took a look at this. The owner, who miraculously escaped with only a few minor injuries to his personal mechanism, demanded not less than \$75 for the outfit. We looked over the remains very, ve-e-ry carefully, hummed and hawed a bit, looked wise, and finally accepted, paying spot cash, and removed the wreck to our shop.

I'll admit that from the picture, it doesn't appear to be worth much money—at any rate not as much as we paid for it. But one must consider that this was in the winter of 1913-14 when Fords were high. However, we'll let you judge for yourself as to its value, after we get through with our story.

When the camera man had taken a view of the poor, wrecked mass of debris, we got busy.

We first examined the power plant, and were agreeably surprised to find, from all outward indications, that it was little damaged. We then removed the engine and thoroughly overhauled it, tightened up connecting-rod bearings, put in new gaskets and ground the valves for good luck, and reassembled it. The whole power unit was in remarkably fine shape, there being very little carbon in the cylinders, and all parts barely worn. Even the bushings in the transmission were not worn enough to warrant replacement.

We then tackled the frame. It looked like a discouraging proposition from the start but by taking each part one at a time, we managed to lay out some plan for repairing

and replacing all broken parts.

The front cross-piece of the frame was so badly doubled up that we did not attempt to repair it ourselves, but sent the entire frame and front axle (which was also twisted) to the local Ford Plant to be made "good as new". The rear axle unit was not so bad off; so we kept that in the shop and fixed it up ourselves.

It really proved to be in very good condition, simply needing a thorough cleaning out. But we unconsciously reassembled it "hind-side before." The result was that when the car was completely reassembled it calmly traveled backward at first speed and forward when thrown into reverse!

This is a common error which frequently occurs in reassembling the Ford rear axle; and a few other makes of light cars. The right and left shafts are of equal length, and the assembly can easily be made with the big bevel gear (master or ring

gear) facing the wrong side.

Of course we had to do that part of the job over; but we finally got the critter in working order, and she ran as good as the day she was bought. We then put her on display and sold within a few days for the neat sum of \$200.00 cash in hand.

Our cost record gives the following expenses involved:

Wrecked chassis .....	\$ 75.00
Frame repair, (new front cross member) ..	6.19
Front Axle Straightened .....	3.00
Radius Rod (new) .....	2.50
Front Spring repair .....	2.25
Brake shoe, (new) .....	.40
Radiator, (2nd hand) .....	11.50
New dash, etc. ....	4.36
New Coil, (Credit allowed for old units) .....	10.00
Gaskets, bolts, nuts, etc. ....	.77
Hood, (New) .....	6.50
Front Wheel, (2nd hand) .....	2.00
Tube 30x3, (2nd hand) .....	.61
Tube 30x3, (2nd hand) .....	1.50
Muffler shell, asbestos, etc. ....	.61

\$127.19

Of course we could have taken care of several of these repairs right in our own shop, and saved the expense of certain new parts and repairing done outside. But our time was rather limited on account of rush work, and we felt that we would rather send these parts out or buy new ones altogether.

You will note that we have not included any labor costs in the above statement. This was not mentioned, as the whole job was undertaken partly as an experiment, just to see what could be done. As an experiment it surely proved its worth, for we realized a nice profit, and incidentally learned a few things about automobiles that have proven themselves of great value since.

—C. L. WHITE

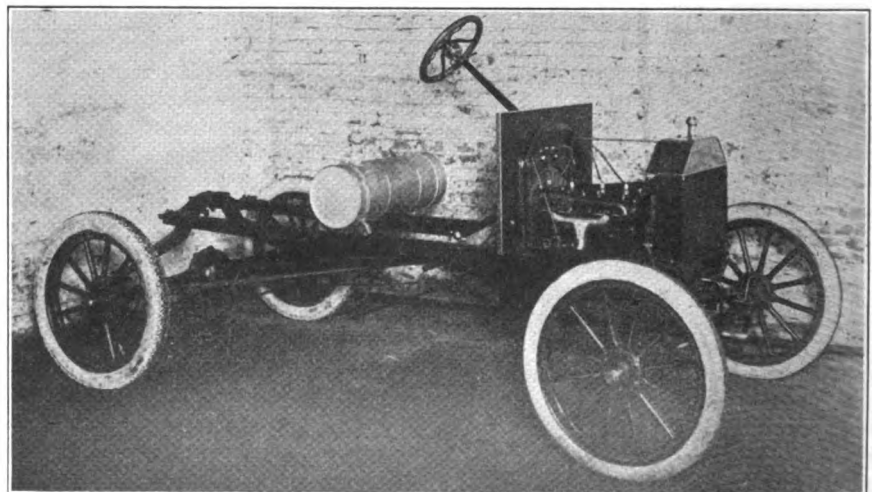

WAS THE ABOVE WRECK WORTH FIXING? THIS VIEW SHOWS IT JUST  
BEFORE IT SOLD AT A GOOD PROFIT



## How the Motor Truck is Aiding the Farmer and the Blacksmith

There could hardly be a better illustration of how the properly equipped motor truck is aiding in solving country transportation problems that have heretofore made

horse's work, the wide-awake smith will do well to keep up with the times, and learn all phases of auto repairing as thoroughly as he knows shoeing. His reward will be great, for every step forward in progress means a greater prosperity, which he will share—if he is prepared.

ing upon mere guess work. Incidentally, you will be in a position to advise your customers as to how to treat their tires to secure the greatest mileage and freedom from tire troubles—and thus win their good will and permanent confidence. Don't think for a moment that by telling them how to avoid tire



THE MOTOR TRUCK IS REVOLUTIONIZING FARMING AS WELL AS THE INDUSTRIES. HERE WE SEE A TRAIN OF SIX HEAVY WAGONS, HAULED BY ONLY ONE TRUCK, BRINGING 300 SHEEP TO MARKET!

farming in many communities unprofitable, than the accompanying photograph.

It shows a Duplex truck, equipped with Firestone single-tread, solid tires hauling a train of six heavy wagons, loaded with 300 sheep into Charlotte, Mich., after traveling ten miles over rough country roads.

The total weight of the train was more than 20 tons. The sheep weighed 15 tons and the wagons, not including the truck, 8,000 pounds. The strain was terrific as may be imagined. In all uses to which the motor truck is put, there are bound to be strains which will sooner or later mean broken parts—and a repair job for the properly equipped smith shop to handle.

The motor truck is performing in its own way, much that has been accomplished by the railroads in the past. It is an agent of civilization, and the farmer and blacksmith alike will benefit by it.

The village blacksmith is the logical truck repairman, and with the truck performing much of the

## The Care of Tires\*

Helpful Hints for the Automobile Repairman

How many realize that thousands upon thousands of dollars are *needlessly* spent every year on tires, when this expense could be practically eliminated—or at least largely prevented by the exercise of care and through a better understanding of tires?

Yet this is a fact, and this article and those which will follow, have been prepared and are being published to tell the automobile repairman certain things that he *should know* about tires.

Good tires will stand abuse, but there's a limit. If you follow this series closely, you can easily absorb sufficient tire knowledge to help reduce the tire bills of the car owner; and to give you a wealth of practical and valuable information, as an automobile repairman. It will teach you to know tires—their faults, the common sources of tire troubles, and enable you to repair them in a really scientific manner, instead of depend-

troubles, that you will lose business. They will appreciate your frankness, and the chances are, that when the car needs overhauling or mechanical repairs, you will be the man who will get the job; because they will then feel that they can depend fully upon your reliability.

Tires, like the engine or other parts of the car, require a reasonable amount of attention and care

**EDITOR'S NOTE:** Correspondence with members of the craft in all parts of the country, reveal a growing activity and interest in automobiles and auto repairing. There are hundreds of blacksmiths who are taking up tire vulcanizing, and it seems a fitting time to offer our readers something special on the subject of tires.

With this object in view we have endeavored to secure articles on this subject and have enlisted the cooperation of the Firestone Tire & Rubber Company of Akron, Ohio.

We present in this issue, the first of a series of articles prepared by one of their tire experts. You are sure to benefit by a careful study of these articles; and should any point arise which is not just clear to you, do not fail to write to the Subscribers' Service Department for enlightenment.

\*Courtesy the Firestone Tire & Rubber Co.



- 1. QUICK DETACHABLE CLINCHER TYPE.
- 2. REGULAR CLINCHER TYPE.
- 3. STRAIGHT SIDE TYPE.

if one expects to secure the best results from them. An owner should insist upon having an expert repairman examine his tires occasionally—much as one would have his teeth examined for those little defects that are constantly undermining their structure. The progressive repairman will seize the opportunity to ask his customer to bring the car into his shop and have him give the tires a thorough examination. There should be no charge made for this inspection, but any defect which might be remedied at the time, and which would very probably add several hundred miles to the life of the tire should be repaired at once and the charge made according to the nature and expense of the repair. You should insist upon these repairs being made at the time, if you can judge from your knowledge of tires, as to how serious the trouble may be.

There have been many refinements in the construction of automobile tires and those built with genuine quality for a base are very dependable; mileage being literally built into a tire. In fact the motorist ordinarily places so much confidence in tire equipment, that the tires do not receive the frequent inspection and attention that is considered necessary for the car itself.

Yet should the engine overheat and the bearings burn out, due to lack of proper lubrication, the result would not be considered an evidence of mechanical error; it would be properly chargeable to oversight and neglect.

It is not always possible to avoid stones and other sharp objects, ruts and severe road conditions, and we shall not attempt in our discussion, to define certain rules or offer impractical suggestions to be followed in using or repairing tires.

The application, care and usage of tires are necessary things to consider, but it is essential to good service that the correct type and size be adopted in the first place. Car construction, power, lateral strains and traction strains to the tires must be kept in mind when deciding upon diameter and cross section of tire equipment, but the weight of car is probably the most important thing.

The weight of the car can be ascertained by running the front half of it on platform scales, then rear half, and the weight carried by each

extra passengers, luggage, power and the speed of the car and its construction as before mentioned. Therefore, in some instances it will be necessary to equip with larger tires.

	Rear	Front
28 x 3 .....	350 lbs.	450 lbs.
30 x 3 .....	375 "	475 "
30 x 3 .....	375 "	475 "
32 x 3 .....	375 "	475 "
34 x 3 .....	400 "	500 "
36 x 3 .....	425 "	525 "
29 x 3 1/2 .....	450 "	550 "
30 x 3 1/2 .....	475 "	575 "
31 x 3 1/2 .....	500 "	600 "
32 x 3 1/2 .....	525 "	628 "
33 x 3 1/2 .....	550 "	650 "
34 x 3 1/2 .....	575 "	675 "
36 x 3 1/2 .....	625 "	700 "
30 x 4 .....	550 "	700 "
31 x 4 .....	575 "	725 "
32 x 4 .....	600 "	750 "
33 x 4 .....	625 "	775 "
34 x 4 .....	650 "	800 "
35 x 4 .....	675 "	825 "
36 x 4 .....	700 "	850 "
37 x 4 .....	725 "	875 "
38 x 4 .....	750 "	900 "
40 x 4 .....	800 "	950 "
42 x 4 .....	850 "	1000 "
32 x 4 1/2 .....	800 "	1000 "

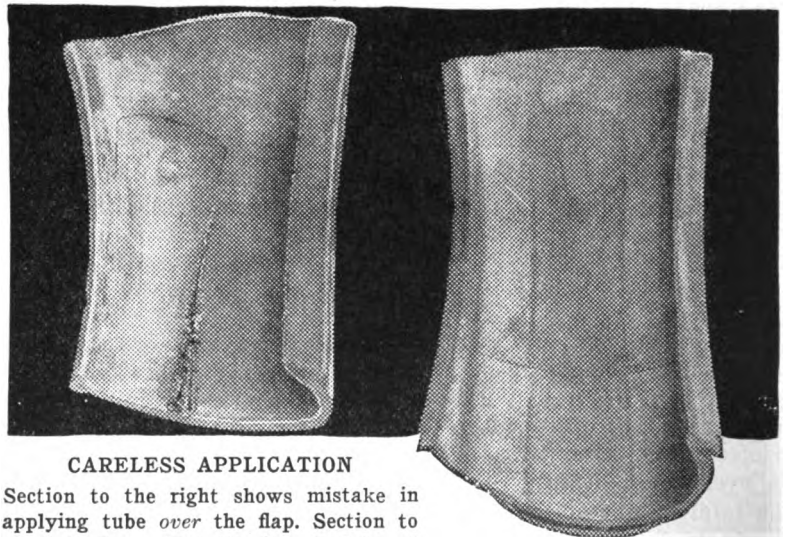

CARELESS APPLICATION

Section to the right shows mistake in applying tube over the flap. Section to the left shows that the flap chafed and cut into the fabric at a point where the tire receives considerable hinging action. A blow-out was the result, and no doubt the tire was blamed for being weak.

tire will be one-half of the respective amounts. Middle of wheel base will be the weight dividing point between the front and rear halves of car. The approach to the scales should be level and, if reasonable care is exercised, the total of the two operations will be within twenty or thirty pounds of the weight of the car when all of it is upon the scales.

The following table shows the approximate carrying capacity of the various standard sizes of tires. These weights are influenced of course, by

33 x 4 1/2 .....	850 "	1050 "
34 x 4 1/2 .....	900 "	1100 "
35 x 4 1/2 .....	950 "	1150 "
36 x 4 1/2 .....	1000 "	1200 "
37 x 4 1/2 .....	1050 "	1250 "
38 x 4 1/2 .....	1100 "	1300 "
40 x 4 1/2 .....	1200 "	1400 "
42 x 4 1/2 .....	1300 "	1500 "
33 x 5 .....	950 "	1200 "
34 x 5 .....	1000 "	1250 "
35 x 5 .....	1050 "	1300 "
36 x 5 .....	1100 "	1350 "
37 x 5 .....	1150 "	1400 "
38 x 5 .....	1200 "	1450 "
39 x 5 .....	1250 "	1500 "
41 x 5 .....	1350 "	1600 "
43 x 5 .....	1450 "	1700 "



36 x 5½	1250	"	1500	"
37 x 5½	1300	"	1550	"
38 x 5½	1350	"	1600	"
40 x 5½	1450	"	1700	"
37 x 6	1350	"	1600	"
39 x 6	1450	"	1700	"
41 x 6	1550	"	1800	"

fitted in clinches of the rims. This is not to be recommended however, as the base width of this style of rim is not suitable for Straight Side tires.

Weight and distribution of car, power, gear ratio, speed and other points are considered by the car engineers and tire makers in determining

their normal carrying capacity, the fabric is not only strained but develops more hinging action and heats at edges of tread. The materials employed in the manufacture of tires are limited in strength like other articles, and when taxed beyond that point will not be efficient.

Much delay and annoyance can be avoided, when ordering new tires, by specifying the style. The accompanying illustration shows three common types of pneumatic tires, known as the Quick Detachable Clincher Type, the Regular Clincher Type, and the Straight Side Type. Regular Clincher cases have stretchable beads and are designed for use on Regular Clincher (one piece) rims; they are sometimes used also on Quick Detachable Clincher rims, in which case it is necessary to use flaps to protect the inner tubes. When used on Regular Clincher Rims, it is desirable for sizes, including the four inch and larger, to use clips or stay bolts to hold beads securely in rim clinches.

Quick Detachable Clincher cases have non-stretchable beads and can only be used on Quick Detachable Clincher Rims and the split type of Clincher rims. This style of tire should *always* be equipped with flaps.

Straight Side or straight bead cases have non-stretchable cables imbedded in the base and are designed *only* for Quick Detachable Straight Side Rims and split type of Straight Side rims. This style should also *always* be equipped with flaps. Straight Side Tires are sometimes used on Quick Detachable Clincher rims having filler beads

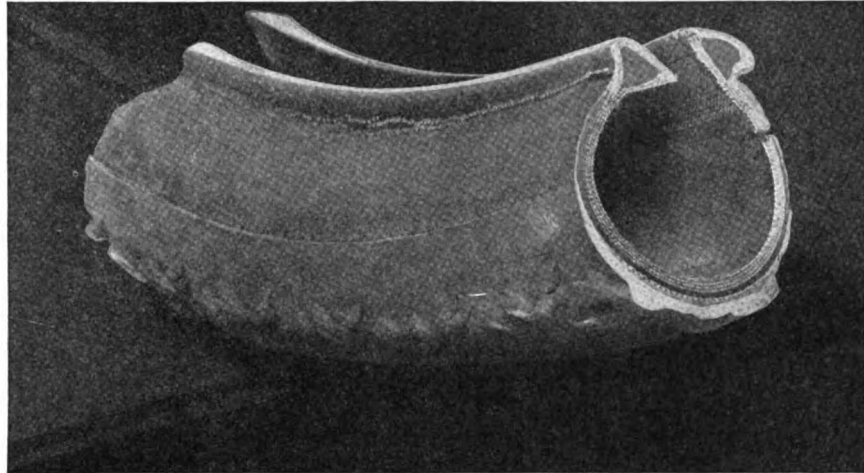

MISAPPLICATION

Tire applied to a rim having reversible rings. The ring on one side of the rim was not reversed, therefore the bead had to adjust itself against the straight side of the ring. The uneven fitting to base of rim and the difference in strain, ruined this tire before it had given full service.

the tire sizes necessary for equipment. It will be appreciated, however, that the usage of cars will vary on account of road conditions, drivers and for other reasons. Therefore it is reasonable to expect some trouble from the tires on a small percentage of cars, even though the equipment on a majority of the cars proves satisfactory in every respect.

When tires are loaded beyond

Oversize tires were primarily designed for exceptional hard service, but have come into general favor because of extra strength, easier riding cushion and longer mileage; in fact, experienced car owners specify the oversize tires, in many instances for original equipment of new cars. The resiliency of larger tires reduces the traction slippage on rear wheels, adds to comfort and lessens vibration to the mechanism of the car.

When oversize tires are placed on front wheels that were originally equipped with regular size tires, the overall diameter will be increased approximately one inch and the speedometer should be readjusted, otherwise the mileage record will be less than that actually traveled.

There is not enough added weight in oversize tires to affect transmission or differential or make any objectionable difference in the power. The advantages of oversize tires, without the inconvenience or expense of changing wheel equipment, are features which mean more certainty and pleasure to motorists.

Before applying tires, remove rust and all other foreign matter from rims. If tires have been ridden deflated at any time, mud may have accumulated on rims and, unless it is removed, the tires cannot seat or fit

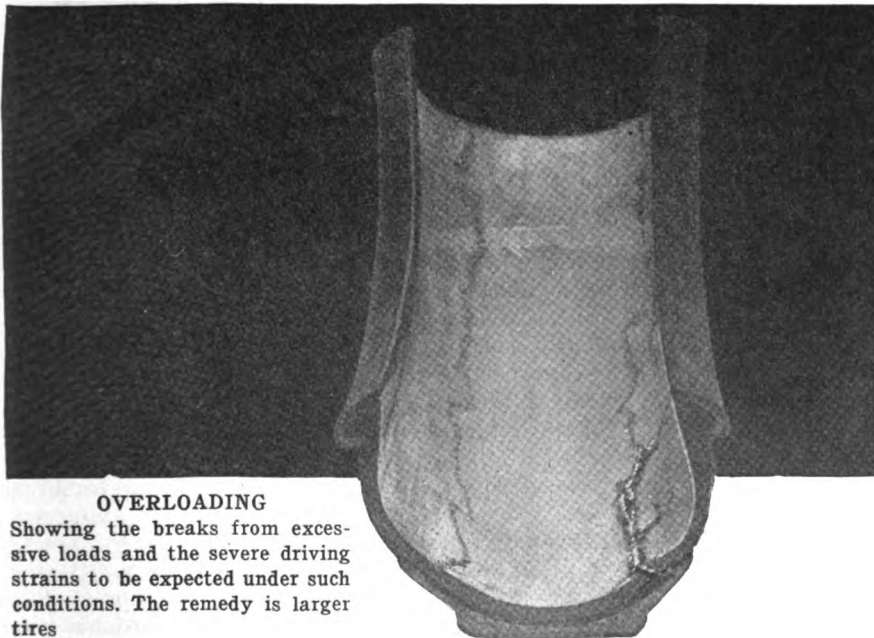

OVERLOADING

Showing the breaks from excessive loads and the severe driving strains to be expected under such conditions. The remedy is larger tires



properly. The danger of pinching inner tubes can be reduced to a minimum by dusting soapstone or powdered mica on the rims, so that the tire beads will slip easily into the correct position.

Inflate inner tubes just enough to round them out before placing them inside of cases. Do not use tubes of the wrong size and be sure that the valves are equipped with spreaders adapted to the particular type of cases used, for instance, Clincher, Quick Detachable Clincher, or Straight Side. Carefully dust the inside of the case and the inner tube

side walls of tires from being chafed and gouged by rim clinches. To avoid, as much as possible, the tendency for Straight Side tires to lift up from rims at inner edges of cables and in this manner permit a rolling action sideways, it is considered advisable to have more spread between the cables than is necessary with the beads of the Clincher type. The use of Straight Side cases on Clincher rims is therefore discouraged. If best results are to be expected from Straight Side tires they should be used only on Straight Side rims which are slightly

a caution against hasty or *careless* application.

If tire users better understood the construction of inner tubes, and things which contribute to their wearing out, it would be easy, indeed, to secure more and better service. Advise your customers that spare tubes should not be carried in cardboard boxes as furnished from your shelves—there is danger of the tubes being chafed. Tube bags are made for this purpose and cost but a trifle.

If the car is equipped with smaller tires on the front wheels than on the rear wheels, an extra tube should be secured for each size.

The cross sections of inner tubes are made a little smaller than the normal air space inside of the cases. It is not advisable to use a 4½-inch tube in a 4-inch case. This usually wrinkles and creases the rubber, with bad results. Do not use a 4-inch tube in a 4½-inch case for any length of time. When this is done the rubber is required to stretch too much and the effect of heat and action due to displacement of air in the tire quickly uses up the nerve and life of the tube.

If put into usage for which it is not designed, the tube will not, as a usual thing, render efficient service. If it was practical to use one size of tube in another size of case, tire manufacturers could effect a big saving in equipment and furnish only a few sizes of tubes.

(To be Continued)

## The Fable of the Successful Shop Owner With the Worm's Eye View, Who Got the Eagle's Perspective

There was once upon a time, a certain smith who had built a big business from a minute beginning.

He was very proud of his achievement, and, being a self-made man, he worshipped his creator more than the statutes allowed. Nature had never intended that he should sit in the seats of the high and mighty, and his every look showed it. His brow was so low that every time he sneezed, his spine shoved his hat down on his face. He ate onions, garlic, and chile con carne for breakfast and he could never understand why his customers always reached for their box of peppermints when he talked. Even the horses shied when they wandered into his shop.

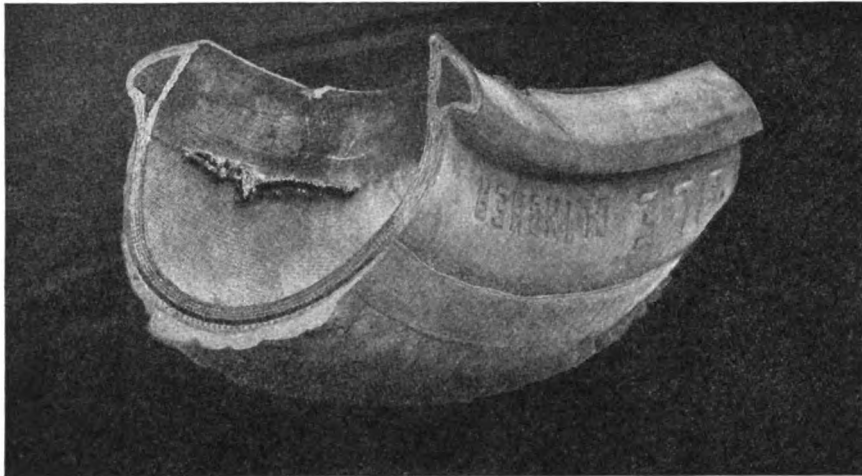

### MISAPPLICATION

This is the same section as shown on page 165. It illustrates the injury to the fabric inside of the case due to the misfit of the bead against the rim.

with powdered mica or talc. This will reduce friction and prevent adhesion of tube to case after being heated in service.

When the tires have been removed for any reason, it is a good plan, when re-applying, to reverse them; that is, to place the worn sides of the tires *toward* the car. It is not generally known, though it is a fact, that almost all the side wear to a tire occurs on the side from car. This is due to road construction, rut wear, curb, scraping, etc.

The life of a tire may be prolonged to such an extent that a great deal more mileage may be secured by turning the tires about occasionally to secure even wear upon both sides.

Careful application of tires is quite as necessary to good service as the selection of correct size for load, or rims being of right design and regular in measurement.

Straight Side Tires are sometimes used on Clincher rims and in such instances, filler beads should be fitted in the rim clinches to prevent

wider at base and permit of the necessary spread between cables. If, for some special reason, it is desired to use Straight Side tires on Clincher rims, the rims should always be equipped with filler beads.

Some tire users do not realize the importance of using flaps, and others, due to indifference or carelessness, place the tubes above the flaps. Illustrations show the injury that may be expected when the flaps are not used as intended.

Users of Quick Detachable rims having reversible rings should be very careful that rings on both sides are suitable to accommodate the type of tire applied, i. e., when using Clincher tires, *both* rings should be in position to properly engage beads and if Straight Side tires are to be used, *both* rings should be in position to fit the straight beads or straight sides of this type.

It probably is not necessary to give detailed reasons pointing out *why* a tire should be properly fitted and this article is intended more as

The only place fate had intended him for was the scaffold—and he wasn't a sign-painter or a paper-hanger. Yet withal he got business, and the iron men seemed to accumulate inside the old jug behind the forge, like the barnacles on a ship's bottom.

He never permitted anyone to tell him anything, because he had cornered knowledge at a time when the market was falling. And he was one of the founders of the University of Experience. What he didn't know could be tabulated on the back of a Pink Buffalo stamp and what he did know kept a famous man's chain of libraries busy hiring new help.

But it happened, perchance, that one bright spring day, there appeared before him an individual who never bent at the knees and who had cut out of his dictionary such words as "awe" and "know it all" and like useful excuses.

Said this individual, after he had reached for the perfume spray, "Know you, Mr. Smith, that you are sorely afflicted with a certain malady known as the worm's eye view. In other words your ego and your business are "interfering" in their fore legs, and you are so close to the ground that you can't see the second story of success. There's a sky, but you know it only by hearsay. What you need is an eagle's eye perspective. Your business is leaking like a four-party line. But in spite of yourself, you've made a success. Opportunities have been knocking on your door with a power hammer. Your loose methods are the village scandal, and I'm here to show you how to hoist the ladder of success alongside your shop and enable you to stand atmospheric conditions in a high altitude. The subway no longer for yours!"

"Show me. Show me!" snorted Ignatz the Ignorant as a self-satisfied grin overspread his browless face.

The stranger drew his chair closer in spite of atmospheric conditions prevailing in the vicinity, and shouted for half an hour.

At the end of that time, Ignatz began to mop the hair back from his nostrils, exclaiming fervently, "Will it? Will it?"

Then the stranger disappeared from out the shop, boldly pocketing a one-dollar-William. Ignatz lifted up his eyes. And lo and behold, and odds-gadzooks. The man had at last

got a glimpse of the bigger perspective. For he held in his hand his first copy of "*the biggest dollar's worth that ever entered a shop!*" And what gets by his eagle eye now is so small that an ant would starve on it.

MORAL—Which teaches us that even a worm may become a bird, and that it is profitable for even the successful smith to read *The American Blacksmith*.



## The Horseshoer

### Shoeing the Horse for Dropped Sole

E. H. MALOON

I have been asked so many times to describe my methods of shoeing horses for certain troubles which are usually very difficult to handle, that I have undertaken to prepare the following brief article, and trust that it will give the desired information.

Dropped sole probably presents as serious a problem to the shoer as any I know of. For myself, I consider it the worst, and usually advise as the best remedy, that the owner put his horse under ground and be done with it. But if he doesn't want to do away with him altogether, the following method may be employed and often works satisfactorily. But the greatest of care must be taken.

Take a thick, narrow shoe and calk it up, putting a plate of band iron over the whole surface between the calks, and fastening this on with stud bolts.

If the sole is well down, I use a shoe that is thick enough so the plate will not touch the sole, and allow for a pad to be inserted between the plate and the sole. I usually place a small bunch of cotton in the cleft of the frog to keep out sand, and fill the space between with a pad of cotton or oakum, making it all even

and solid to give a firm and easy support to the sole. This is covered with a soft leather pad next to the plate.

By shoeing after this fashion I have made a drop-sole horse go very well. A particular case which will carry out my point, was one handled some three years ago: A horse, that was almost too lame to walk, was brought to me. I could find nothing specific the matter, and shod him on what I call general principles; that is, I put on a bar shoe, took all pressure off his heels, put on a pad, and packed his foot in tar and oakum.

All this did not help him and after some weeks he came again, and when we removed his shoe we found a discolored place between the hoof and sole at the toe. We cut in and found a large quantity of clear white matter, something I had never seen in the bottom of a horse's foot before. I had always found dark, watery matter before, such as comes from thrush and canker.

After I had put his foot down it began to run matter at the top of the hoof. We cleaned the wound out with creolyn and in probing found the laminar all gone for three inches each way. We put on a pad and plate as described and advised the man to see a Vet. This he did and got some medicine to put in the wound. We found that the horse became sound in his travel right away. The hole is still there, and there is no connection between hoof and coffin bone. We support the sole and he goes over our hard roads at a good trot and don't go lame. We simply keep the sole of his foot from settling.

Contracted feet is another thing that the shoer is expected to remedy. I don't know what he can do to help this trouble by mere shoeing, except to cut the wall down to the lowest possible limit; thus getting rid of that hard unnatural horn that is gripping the live tissues of the foot, and pack with tar and oakum. (I don't know of any thing that can equal this old fashioned packing.)

Now the next two things to be done is to soak the foot out in hot water—water that you cannot hold your hand in. Have it just deep enough to cover the hoof. Next blister the coronary band at least three times. Wait for the blister to get sound before putting on another; usually about 20 days. I have seen new hoof roll out as large as a lead pencil, all around the hoof. As that





grows down and is taken care of, the horse will go better. To be successful in this, the horse's blood must be in excellent condition and his vitality normal. All this can be brought about by good care and a feed which is adapted to him, I can tell from the looks of a horse whether he is fed right or not. If the driver does not properly feed and care for his animal, he has no business driving and caring for them. I have always found that my horse needed a little medicine at times. The blood of the horse is his life. It digests his food, heals his wounds, and will made his front feet grow soft and large if one devotes the proper care to him. It is fever that makes them small and hard. Remove the fever and he will grow new shells on his feet if the tissues are not completely gone.

It is with the utmost satisfaction that I read the article in the February number of the American Blacksmith, by A. L. Camp, on the different shapes of horses feet and the shoe best fitted for each; especially, the large flat foot.

The shoe he recommends is a shoe I used quite extensively twenty or more years ago, but we had to make them ourselves as there were none on the market then, and the conditions were not so urgent as they are now and so they passed by; but I have sent a pattern, and have written to the the United States Horse Shoe Co., concerning them and they may take notice and give us something ready-made that will soon become a favorite. It is surely a necessity.

I am sorry that the time when horse shoers had to learn the trade and took an interest and pride in what they did, seems to be passing. We then shod the driving horse as well as we could, but he has gone and we have the automobile in his place. We next had the livery horse, that taxed our skill to the utmost. He too, is going fast.

Our farm horses were native bred and a twelve hundred pound animal was a large horse. We took pride in shoeing these horses. We had dirt roads and we kept their feet as near the earth as we could and gave them shoes that were adapted to their needs, as well as we knew.

Now things are all changed. The man who shoes horses is generally a man who has learned no trade. He knows how to fit a shoe to a foot so his driver can get it on. They know very little about the foot they are shoeing, or what they can do to make the horse go better, and do his work easier.

The roads are like stone. The horse wears his shoes out and must have immense, large and high calks, which are a torture to him and the man who puts them on should be punished for cruelty to dumb animals. The whole matter makes me sick and I wish there was a law that no man should shoe a horse until he passed an examination before some tribunal that would reject him or give him a right to shoe horses.

My advice is this: let us make the best of conditions as we find them today and get us a shoe that we can put on a flat foot and leave the walls as large and thick as they will grow, thus giving strength. When large high calks are demanded, let us put a plate on the shoe, a leather pad over the foot and between the plate and pad, put in a soft support for the sole to rest on and thus save the horse from torture, and give to

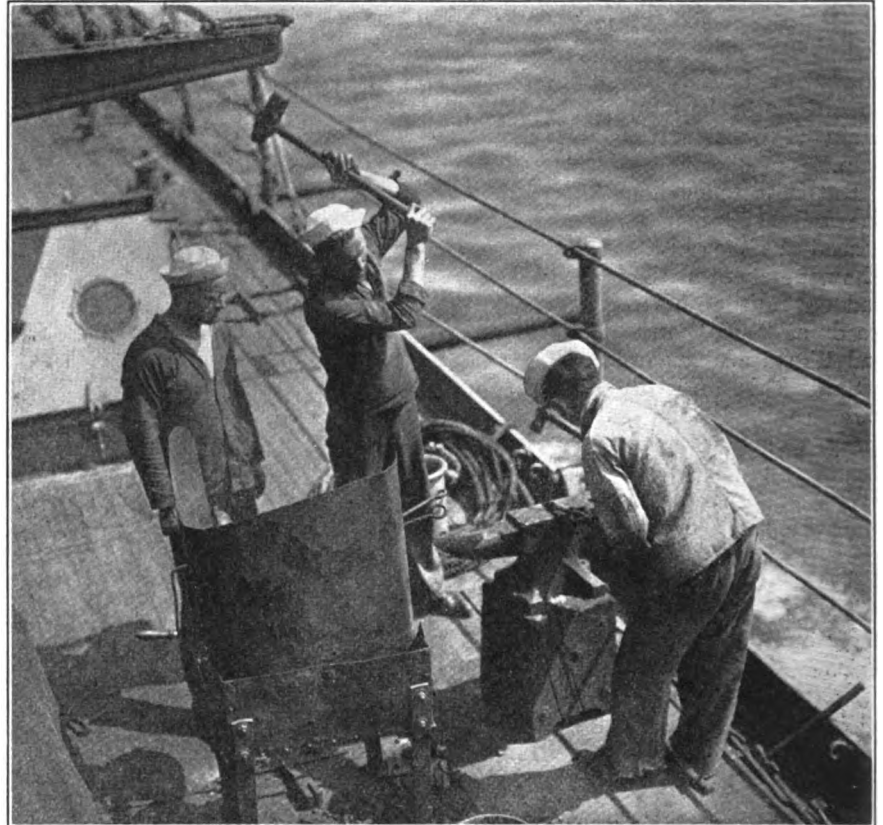

STURDY ANVIL-RINGERS ON THE DECK OF A MAN-O'-WAR

But enough of this. A. L. Camp's article is all right though I think he should have showed up the man who is putting on a shoe with calks that set the horses foot from 1½ to 2 inches above the floor, thus leaving a great, large round sole with no support at any time. On this sole rests the coffin zone and the whole chain of bones and joints from the foot to the top of shoulder nothing to hold them, with the sole off the ground, except a thin layer of membrane, called laminar, which holds the coffin bone to the walls of the foot. Now this laminar was not intended to hold the whole strain of the weight of the horse, but simply to hold his foot shell to the coffin bone; hence is it any wonder that when the support is taken off the frog and sole, the laminar soon gives away and we have a dropped sole and a worthless horse?

his owner a much longer life of faithful service.

Think this matter over and have something to say about it, and sooner or later we will have what we want, ready-made and ready to fit.

#### SOMETHING ABOUT UNCLE SAM'S BLACKSMITHS

Perhaps some of the most unusual blacksmith shops to be found anywhere are those maintained by Uncle Sam, and it is surprising to learn how very extensive his smithing operations are in this field.

Aside from the shoeing of horses for the cavalry and artillery forces, the Federal Government has found it necessary to employ expert blacksmiths to look after the vehicles and the shoeing of horses employed in the conduct of the public domain—the Forest Rangers, guardians of our National Parks, etc.

But the most novel as well as the most numerous governmental blacksmith shops are those in the Army and Navy. Every fort or military post where cavalry or artillery forces are stationed now has its own blacksmith shop and so likewise does



everyone of our warships, large enough to warrant one.

It is nothing short of astonishing how much blacksmithing work there is constantly to be done on a first-class battleship; but it must be borne in mind that a twentieth-century sea fighter is nothing more or less than a huge floating fortress of solid metal construction, and every alteration, every change or reconstruction and every repair job of minor character is more than likely to be a job for the ship's blacksmiths.

There are several blacksmiths on every first-class man-o'-war, and Uncle Sam provides them with the best of equipment, including portable forges of the latest approved models. They are liberally paid, the average rate at the start being \$55 a month; but in comparing this with a blacksmith's earnings in the commercial field one must consider that this sum is net. That is, the Government supplies its blacksmiths with free board, lodging, clothing and medical attendance, leaving his salary clear. Besides there are certain emoluments for long service, etc.

Many a blacksmith has saved up sufficient money during one or more terms of enlistment to establish himself in a well-equipped shop of his own when he has retired to private life, and his practical, all-round experience has proven of great advantage, not to mention the broadening influence of travel.

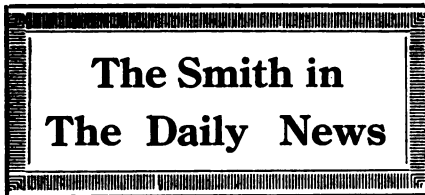

The Smith in  
The Daily News

**Odd Mention of Anvil Ringers and Knights of the Forge in the News of the Day**

**U. S. Navy Needs Blacksmiths**

In keeping with its campaign of preparedness and putting the equipment upon a solid fighting basis, the navy department has issued bulletins urging enlistments in trades heretofore closed to candidates. Formerly it was almost impossible to secure one of these trade positions directly upon enlistment—the candidate having to go through a previous course of training as an ordinary seaman.

A comparatively high wage is paid at the outset, blacksmiths receiving \$55 a month and keep. Increases are said to be rapid, according to the ability shown.

A letter received from Washington, urges local recruiting stations to do their utmost to stimulate immediate enlistment, saying:

"The demand for men in view of the increase voted for the naval complement is now greater than ever before and as this is the first line of defense in case of war, the general public and all who desire to aid in upholding the principles and traditions of the flag are asked to cooperate in building up the American navy to its maximum strength."

Lewis C. Howe, of Rutland, Vt., has passed the examinations at the local navy recruiting station and gone to Burlington for orders. From there he will go directly to a receiving ship in Boston or New York where he is to go into the service as a blacksmith.

**Blacksmith Indicted for Selling Liquor to Indians**

Not content with following the peaceful, honest ways of his craft, a California blacksmith carried on an extensive trade in liquor with the Indians in his vicinity.

The enjoyment of the fruits of his labor was short, however, for ere long the minions of the law hauled him off to court. Here he pleaded guilty to the charge and is now beginning a year's rest amongst the rats and cobwebs of the local county jail.

**California Shoers About to Raise Prices**

Horse shoes seem likely to join in the onward and upward march of high-priced necessities. As this issue goes to press, we learn that a meeting of the Master Horseshoers' Protective Association is to be held to ratify an increase of 50 cents in the cost of a set of horse shoes. The present price is \$2.50.

This is right in line with the general increase in prices in all parts of the country, made necessary by the continually rising cost of iron and steel products.

**War Prompted Suicide of Blacksmith**

Police fingerprint records helped identify the body of a man who jumped off the Williamsburg Bridge into New York Harbor, as that of Rudolph Wesley, a blacksmith and a Hungarian.

Records of the Police Department showed that he had been arrested in June last, for attempting to jump from the same bridge.

Mrs. Wesley stated that her husband had allowed the war to pray upon his mind, and had shown suicidal tendencies several times.

**Blacksmith Must Pay**

J. R. Watenphul, the village blacksmith and automobile mender of Augusta, Wis., will have to pay Dr. Frederick Smith of Chicago, \$2,000 for alienating the affections of the doctor's wife, Martha Smith, formerly Martha Kapinski, a belle of Augusta. The supreme court upheld the award.

The original suit aroused interest all over the country. Dr. Smith's wife was said to have gone to Watenphul after being forgiven several times by her husband and taken back.

**Man Frozen to Death in Smith Shop**

West Virginia witnessed the coldest weather in its history this past winter, with the temperature ten degrees below zero accompanied with winds of high velocity. Much suffering and considerable property damage have resulted.

An unknown foreigner was found frozen to death in a blacksmith shop at Sivad where he had taken refuge from the storm.

**Smith Shop and Equipment Stolen**

A peculiar case has come under our observation. A Louisiana blacksmith leased certain premises upon which to establish his business, paying \$16 a month. After building up a successful trade, and in no way indebted to the owner of the premises, he notified the latter of his desire to move his shop to a more favorable location.

The owner immediately put him out of the shop, seized all material and began running the business himself, refusing the blacksmith access to the shop. He is still running it and the rightful possessor of

the shop, tools and trade is without his lawful means of making a living.

As this issue goes to press he has instituted suit for \$10,000 damages in the Civil District Court and we are of the opinion that he will be properly recompensed.

**Blacksmith Leaves Many Descendants**

Jacob H. F. Hollinger, a retired blacksmith, of Lebanon, Pa., at the age of 82 years died from the effects of a stroke of paralysis. He had been a resident of Lebanon county for most of his long life, retiring from business twelve years ago.

He leaves his wife, twelve children, 47 grandchildren and seven great grandchildren.

**Blacksmith Invents a New Kind of Bolt!**

Some time ago the police in a certain Western town made a raid upon a club where gambling was suspected of taking place. The names and addresses of those caught on the premises were taken and in due course the offenders were summoned to appear in court.

One of the offenders, on being asked what trade he followed, replied:

"I am a blacksmith."

"What were you doing when the police entered?"

"Well, your honor," came the answer, "I was just making a bolt for the door."

**Dayton, Ohio Will Operate Own Blacksmith Shop**

City Purchasing Agent Smith purchased the entire outfit of the blacksmith shop of Reuben Saylor, Broadway and German-town streets, for the purpose of establishing a city blacksmith shop. The shop will be established in connection with the city stables and will be used to take care of the 67 horses owned by the city.

**Forges Cross for Kaiser**

Anglophobia does not limit the capacity for loyalty to Uncle Sam in the case of an Irish blacksmith of Mississippi. Having forged an iron cross with his own hands, Tom Collins, of Biloxi, has sent it with a withering message to filibustering Senator Vardaman as "a token of the Kaiser's esteem" and as "a reward for service in the interest of Germany."

**Shop Smiths Quit Work**

Six hundred Western Maryland shop employees in Hagerstown have struck. Boiler makers, blacksmiths and sheet metal workers have laid down their tools and gone out in sympathy with the machinists who struck sometime before. Strike breakers are expected from Baltimore and the local police are guarding against outbreaks. The strikers claim that all crafts in the Western Maryland shops in Cumberland, Elkins and Hanover will strike in sympathy.

**Blacksmiths Show They Are for Uncle Sam.**

The employees of the blacksmith shop of the Chambersburg Engineering Company, Chambersburg, Pa., have purchased a flag and raised it over their shop. The flag is 5 feet by 8 feet. The men also decorated their machines with smaller flags.

Arthur Hitch and Charles Greer, of Hastings, Neb., have enlisted in the national guards. Arthur as a blacksmith and Charles as a mechanic. They are now at Fort Logan, Colorado, where they expect to stay for a few weeks.



## Why is a Ford?

I have looked at the canopied coaches that ride

Like a ship of the gods on the sea,  
And the swaths of their cutting are heavy  
and wide,

Like a bungalow out on a spree;  
I have heard of their glory in story and  
screed,

But the more of their glory I scan  
The better I know that the car that I need  
Is a car that will work for a man.

I am not of the gods; I reside on the  
earth;

I am fond of the neighborhood, too,  
And I want a machine that will render  
its worth

In the things that I want it to do;  
And the ship of the gods may be good  
for the gink

With a million or so in his hoard  
But I know what I know, and I think  
what I think,  
And I think I will get me a Ford!

I will get it, and settle, and put it to use  
And the ships of the gods may cavort;  
They may try to run them on a gallon of  
juice—

But, the Ford gets there first—on a  
quart.

They may smile at the little machine that  
I run,

They may laugh, if they like to, and  
can,

But the car that I want for myself is the  
one,

That is worth what it costs to a man.

**Joke a Ford and you joke at the sands of  
the seas**

And the leaves when the forests are  
full;

When a bull rushes into a nest full of bees  
Is the joke on the bees or the bull?

They are common—for everyone has 'em  
but me,

And I feel pretty lonesome and bored,  
And I want what will be what I want it  
to be,

So I'm going to buy me a Ford.

—Scranton Tribune—Republican.



## Heats, Sparks, Welds

"In times of peace, prepare for"——  
More Business, is our advice. Be prepared  
for that profitable tractor, implement and  
automobile business.

We enjoy hearing from our friends, but

fer t' love o' Mike, man—don't use a  
chunk of coal or a cold chisel to write  
with. We've got good eyes, but——!

Someone has written about the smile  
that is worth a million dollars, and  
doesn't cost a cent. That's one way of  
advertising, Mr. Man—just \$mile. You  
would be surprised to see how far it goes.

Another good habit, and one of the best  
that any man can cultivate is a cheerful  
disposition; it means everything to the  
man who has it, and the man who doesn't  
possess it is woefully lacking in one of the  
great qualities that helps much toward  
success.

Don't try to run your business after  
the fashion of old Bill Weatherbee. We  
heard Bill had been buying a horse. When  
we asked what he wanted a horse for,  
he said: "I got t-draw hay." "What's  
the hay for, Bill?" we queried. And Bill  
answered: "T' feed my hoss."

Place yourself among the leaders on the  
Honor Roll.—not just because we say so,  
but because it is a sound investment. It  
will save you money—just like buying any  
other commodity in quantities. And it  
will insure your receiving the biggest  
dollar's worth of craft information that  
ever came your way. Think it over.

Spring is the time to begin advertising  
your shop. It will pay you over and  
over again to have an attractive sign  
painted to hang over the door. But let  
that be only the outward sign of your  
progress. Clean up that junk pile,  
straighten up the shop, make everything  
look spick and span.

"Autotroublitis" is a disease that will  
prevail throughout the coming months. It  
is common to all auto owners. None can  
avoid it. It is expensive to cure, but  
costs less if taken care of in time. You  
are the natural doctor of automobile  
troubles. So why not plan to open an  
auto hospital this spring?

The fellow who will pay if he's got it,  
and the fellow who is slow pay, and the  
dead-beat, are all pretty much in the same  
class—to be avoided by the blacksmith  
who's out after Uncle Sam's Welcome  
Williams. It is about time you cleaned  
up all those old accounts and started with  
a clean slate. But go about it with a  
purpose—tactfully, firmly and persistent-  
ly.

Easy Street is made up of many men  
who got their start from the invention  
of some simple tool or contrivance. Ever  
scheme up something of your own to make  
work easier? Sure you have. And we'll  
bet others would find as much value in  
it as you have. So why not really find  
out if you cannot market it—and let us  
help you. We'll gladly tell you what we  
think of it, and what could be done in  
the way of selling it.

And speaking of spring cleaning—just  
another word as to cleaning up those  
ancient debts. Use this as an argument:  
tell the people who owe you, that you are  
cleaning up the shop to better accomo-  
date customers, and that you want to  
clean up all outstanding accounts at the  
same time. Show him you are in earnest—  
both to collect their account, and to offer  
them more in the way of service than  
they can get in any other shop in town.  
Chances are they'll come across.

Some folks we know, have to travel all  
over Europe to get their education. Then  
there are smiths who aren't satisfied to

settle down and build up a business, but  
have to move around every once in a  
while, thinking that they will pick up a  
broader craft knowledge. That's all  
right to an extent, but isn't it a better way  
to let your craft paper do the traveling for  
you? The American Blacksmith reaches  
the four corners of the earth, and the wise  
smith reads it constantly—and puts its  
ideas into practice.

Make it a point to keep a record of  
the cost of every new job that comes  
into your shop. Then you will be in a  
position to quickly estimate the cost of  
a similar job when it comes along, and  
there will be less dickering about prices.  
Moreover it will identify you as a good  
business man. Begin today. Resolve that  
the first job of a different nature—a weld-  
ing job that demands a new method of  
handling, for instance, will be recorded in  
a note book. The cost of materials, your  
labor, overhead and profit.

Appearances are not always a correct  
indication. Clothes may make the man,  
but a "high stepper" may belong to a  
dead beat, and the owner of a great big  
touring car may be poor pay.

Better far to say nothing, whatever, re-  
garding your competitor, than to knock  
him. If he does poor work, people will  
find it out sooner or later, and if his work  
is better than yours, they will know it no  
matter what you say. Boost your own  
business, by hammering on your own  
anvil.

There's a type of salesman who never  
needs to take cocaine when the dentist  
treats his nerve. Frequently the smith  
encounters such, who tries to sell him  
something, that, ten to one he doesn't  
want, or if he does, proves to be worth-  
less. Right here we want to put in a  
word: spring is the season they begin to  
get away from the cities and ply their  
business. But you just be ready and don't  
take chances. Always insist on buying  
an advertised article—"Our Journal" pro-  
tects you against fraud and you are safe  
in buying anything advertised in its pages.

It's the welding of brain and muscle  
that brings the shining iron men into the  
modern shop. And the best welding com-  
pound on the market is your craft paper.  
Pounding two pieces of iron together for  
twenty-four hours will not weld them to-  
gether as firmly as fifteen minutes work  
with a good welding compound. Neither  
will twenty-four hours a day at the anvil  
teach you all you need to know about  
the craft. It's the combination of head  
work with muscle, welded by a com-  
pound made up of the ideas, talks, kinks,  
and timely trade articles in your journal  
that really count.

Spring cleaning!—yes it's here again.  
And it's a right good time to take a long,  
long look over everything in the shop.  
How are the walls and ceilings? Dirty  
and grimy with accumulated soot and  
dust? Why not begin right away to  
brighten them up with a coat of white-  
wash? Benton has as good a recipe in his  
book this month, as any you'll find. Use  
it. Are your tools where you can always  
get at them? An easily erected tool rack  
will save steps and time. Are you still  
hanging on to that scrap pile? There could  
hardly be a better time than now, to dis-  
pose of it at best prices. Are you using  
clean smithing coal, good metals,—the  
best materials? They may cost more, but  
it pays in the end.

# Our Honor Roll

## IT'S EASY NOW TO BE AMONG THE LEADERS.

Do you want to place your name among the leaders? It's easy now. If your subscription expires with the April, 1917, number, send in a little five spot (\$7.00 in Canada or 1£ 14 sh. in other countries) and your name will be placed in the April, 1917, class and you won't need to think about your subscription account for years to come. There are only a few subscribers whose subscriptions are paid up to 1927. Put your name in that group. It's easy if your subscription expires this month—April, 1917. If it doesn't expire this month, ask the Subscription Department when it does expire and how you can get into the leaders' class.

### A NEW NAME IN FIRST PLACE?

The Fix-It Shop has held first place for some months, but we understand some one is planning to take the lead. A twenty-year order will clinch the lead for some one. Who will it be? Watch out for a new name in first place. Something's going to happen soon. Keep your eye on this Roll of Honor.

#### U. S. and Mexico

2 yrs.....\$1.60 save \$ .40.....\$2.00	Canada	5.00.....10 sh. save 2 sh	Other Countries.
3 yrs..... 2.00 save 1.00..... 2.70		1.05.....14 sh. save 4 sh.	
4 yrs..... 2.50 save 1.50..... 3.20		1.80.....18 sh. save 6 sh.	
5 yrs..... 3.00 save 2.00..... 3.75		2.50..... 1 £ save 10 sh.	
10 yrs..... 5.00 save 5.00..... 7.00		5.50.....12 14 sh. save 12 6 sh.	

Send your order and remittance now—today. Don't wait until you forget all about it. You'll never regret it. Our subscription insurance saves you money. The sooner you begin saving, the more you save. There is no better time than NOW.

NAME	Subscription Paid to	NAME	Subscription Paid to
The Fix-It Shop, Utah.....	July, 1935	J. S. Damm, Iowa.....	Jan., 1925
J. A. Torray, Mass.....	Dec., 1923	J. M. Withers, Hawaii.....	Jan., 1925
W. C. Watt, Kansas.....	Dec., 1920	N. E. Quirk, Pa.....	Dec., 1924
I. J. Stites, N. Y.....	Jan., 1929	F. H. Jarvis, Indiana.....	Dec., 1924
Waddington Farm, W. Va.....	Mar., 1928	George Tatum, Jr., Fla.....	Dec., 1924
W. W. Egly, Pa.....	June, 1927	I. Clark, Va.....	Dec., 1924
E. A. Krebbel, Kan.....	May, 1927	A. N. Estes, Va.....	Dec., 1924
F. Roschy, Pa.....	Feb., 1927	J. Bailey, Manitoba.....	Dec., 1924
J. W. Howes, Md.....	Feb., 1927	E. G. Naylor, Md.....	Dec., 1924
W. Stocker, Texas.....	Feb., 1927	Halvorson Brothers, S. D.....	Nov., 1924
W. Pontius, Iowa.....	Feb., 1927	P. Schicks, Washington.....	Nov., 1924
M. Goller, Pa.....	Feb., 1927	H. E. Snyder, Oregon.....	Nov., 1924
A. A. McLean, Nev.....	Feb., 1927	J. A. Stewart, Ky.....	Oct., 1924
J. Murphy, Calif.....	Jan., 1926	C. Richencker, N. Y.....	Oct., 1924
C. M. Adams, Conn.....	Jan., 1927	W. L. Bertholf, N. J.....	Oct., 1924
C. Kadelef, Iowa.....	Jan., 1927	J. W. Hewson, S. Africa.....	Sept., 1924
H. Pass, Minn.....	Dec., 1926	Ed. Larson, N. D.....	Sept., 1924
A. Granadam, Ill.....	Dec., 1926	R. T. Monk, Illinois.....	Sept., 1924
Plateau Shoeing Shop, Colo.....	Dec., 1926	W. T. De Young, Illinois.....	Sept., 1924
C. J. Hale, Wash.....	Dec., 1926	C. W. Taylor, Pa.....	Aug., 1924
John H. Schneider, Cal.....	Dec., 1926	Charles Wells, Colorado.....	Aug., 1924
J. C. Smith, Washington.....	Dec., 1926	H. G. Weaver, Pa.....	Aug., 1924
H. Grimm, Utah.....	Dec., 1926	Working Men's College, Vict.....	June, 1924
F. L. Matlocks, Ark.....	Sept., 1926	F. M. Kenoyer, Nebr.....	June, 1924
E. B. Jones, Wisc.....	Sept., 1926	O. Anderson, Ariz.....	May, 1924
J. Taylor, Calif.....	Oct., 1926	R. C. Frederick, N. D.....	May, 1924
W. H. Branch, N. C.....	Oct., 1926	H. L. Fenton, New Mexico.....	May, 1924
J. Clarke, Jr., Queens, Aust.....	Aug., 1926	J. Carl, Iowa.....	May, 1924
I. Boles, Ohio.....	July, 1926	J. E. Little, Pa.....	May, 1924
H. A. Buchner, Mich.....	July, 1926	H. I. Brenzle, N. Y.....	Apr., 1924
J. M. Mitchell, N. Y.....	July, 1926	W. E. Parr, Iowa.....	Apr., 1924
M. Broton, N. D.....	June, 1926	F. Sramek, Nebr.....	Apr., 1924
A. Schmitt, Nebr.....	June, 1926	L. A. Hulen, Calif.....	Apr., 1924
D. Ackland & Son, Man.....	May, 1926	J. E. Ray, Minn.....	Mar., 1924
H. Pliet, Ore.....	May, 1926	A. Hulstrand, N. D.....	Mar., 1924
J. Sinclair, W. Australia.....	May, 1926	W. F. Rike, Wisc.....	Mar., 1924
P. Sowa, Oregon.....	May, 1926	P. F. Seibert, Calif.....	Mar., 1924
E. P. Dignam, S. Australia.....	Apr., 1926	H. Roeschwaetter, Mo.....	Mar., 1924
A. A. Peterson, Iowa.....	Apr., 1926	W. B. Briant, N. J.....	Mar., 1924
G. F. Bowers, Okla.....	Apr., 1926	A. Bosch, N. Y.....	Mar., 1924
W. Pochain, Oregon.....	Mar., 1926	D. Van Valkenburg, Mass.....	Feb., 1924
A. Garver, Ohio.....	Feb., 1926	A. E. Johnson, E. I.....	Feb., 1924
C. Burton, Miss.....	Mar., 1926	F. Jacobs, Ohio.....	Feb., 1924
J. Murphy, Calif.....	Jan., 1926	A. J. Ferry, Illinois.....	Jan., 1924
J. F. Murphy, Nev.....	Jan., 1926	E. K. Walker, Calif.....	Jan., 1924
F. Kearnes, Illinois.....	Jan., 1926	H. D. Erskine, Vermont.....	Jan., 1924
J. N. McIntire, Pa.....	Jan., 1926	E. Fowler, Pa.....	Jan., 1924
W. Post, N. Y.....	Jan., 1926	Breen & Son, Ireland.....	Dec., 1923
Powell Brothers & Whitaker, Eng-land.....	Jan., 1926	M. Lamoreaux, Ohio.....	Dec., 1923
O. Temple, Idaho.....	Jan., 1926	C. E. Davis, N. Y.....	Dec., 1923
N. Karolewicz, S. Dak.....	Jan., 1926	F. W. Copeland, Kansas.....	Dec., 1923
E. L. Lain, N. Y.....	Dec., 1925	J. L. Tomlin, Kansas.....	Dec., 1923
J. A. Hulvey, Illinois.....	Dec., 1925	H. A. Davis, N. Y.....	Dec., 1923
Williams & Turner, W. Va.....	Dec., 1925	E. H. Troyke, Illinois.....	Dec., 1923
J. J. Devine, N. J.....	Dec., 1925	D. B. Johnson, Iowa.....	Dec., 1923
P. Nelson, Minn.....	Dec., 1925	S. Horton, Calif.....	Nov., 1923
M. Kennedy, Tas., Australia.....	Dec., 1925	J. Spratt, Mass.....	Nov., 1923
H. Jones, England.....	Dec., 1925	F. Watkins, N. H.....	Nov., 1923
A. J. Wasmuth, Idaho.....	Nov., 1925	F. Koppala, Ala.....	Nov., 1923
J. G. H. Mallett, Queens, Australia.....	Nov., 1925	Y. C. Llenert, S. Australia.....	Oct., 1923
A. W. Speir, Ohio.....	Nov., 1925	W. B. Abell, N. Y.....	Oct., 1923
W. E. Clapper, Texas.....	Nov., 1925	W. R. Turner, Man.....	Oct., 1923
G. H. Laly, Mass.....	Nov., 1925	A. J. Brookman & Co., Vict., Aust.....	Sept., 1923
L. Krause, Ind.....	Oct., 1925	C. Nelson, Nebr.....	Sept., 1923
Reynolds Brothers, Pa.....	Sept., 1925	J. Hughes, Ohio.....	Aug., 1923
F. W. Erens, Calif.....	Aug., 1925	H. M. Anderfuren, Calif.....	Aug., 1923
C. E. Allen, Nebr.....	Aug., 1925	Camp Brothers, Texas.....	Aug., 1923
A. E. Spangberg, Oregon.....	May, 1925	L. C. Larson, Iowa.....	July, 1923
D. M. Kile, Okla.....	Apr., 1925	S. Effner, South Africa.....	July, 1923
G. Gullgren, Iowa.....	Apr., 1925	G. L. DeWitt, Mont.....	July, 1923
Q. Fredericks, Minn.....	Mar., 1925	W. W. Gregg, Texas.....	July, 1923
V. Priesmitz, Wisc.....	Mar., 1925	W. R. Stroupe, N. C.....	July, 1923
E. Price, Illinois.....	Feb., 1925	O. C. Young, Michigan.....	June, 1923
D. C. Garber, Ohio.....	Feb., 1925	Otto Stippel, Pa.....	June, 1923
J. H. Kurt, Illinois.....	Feb., 1925	A. Chapman, N. Y.....	June, 1923
E. R. Hittsman, Ohio.....	Feb., 1925	C. Burk, Md.....	June, 1923
H. F. Schreiber, Pa.....	Feb., 1925	F. H. Shupe, Pa.....	June, 1923
		J. C. Stover, Pa.....	Apr., 1923

NAME	Subscription Paid to	NAME	Subscription Paid to
W. Scheonover, Pa.....	Apr., 1923	J. A. Johnson, N. D.....	Apr., 1921
J. M. Rumire, Iowa.....	May, 1923	D. H. Laird, N. Y.....	Apr., 1921
Lowndale Brothers, Mo.....	Mar., 1923	A. J. Prue, N. Y.....	Apr., 1921
J. Carswell, Ark.....	Mar., 1923	C. A. Butler, Ohio.....	Apr., 1921
G. E. Glazier, Ohio.....	Mar., 1923	E. Mossner, Queens, Australia.....	Apr., 1921
F. Gath & Co., S. Africa.....	Mar., 1923	W. F. Tippey, Mich.....	Mar., 1921
T. Bradley, N. S. Wales.....	Mar., 1923	J. T. Rehm & Son, N. Y.....	Mar., 1921
L. T. Needham, Illinois.....	Feb., 1923	W. C. LeBow, Mo.....	Mar., 1921
G. C. Disinger, Miss.....	Feb., 1923	William Pate, Mo.....	Mar., 1921
J. Wieber, Minn.....	Jan., 1923	A. T. Jameson, Colorado.....	Mar., 1921
Z. A. Enos, Minn.....	Jan., 1923	C. Alexander, N. Y.....	Mar., 1921
W. G. Wise, Calif.....	Jan., 1923	J. Fenel, Wisc.....	Mar., 1921
F. S. Bishop, South Africa.....	Jan., 1923	H. Cornils, Oregon.....	Mar., 1921
J. Curran, Arizona.....	Jan., 1923	C. Schmid, Nebr.....	Mar., 1921
S. P. Harney, Mont.....	Dec., 1922	J. Schwarzmann, D. C.....	Mar., 1921
W. Breckner, Okla.....	Dec., 1922	M. Stettner, Minn.....	Mar., 1921
J. Pabina, Nebr.....	Dec., 1922	N. E. Hart, Okla.....	Feb., 1921
P. Frederickson, Iowa.....	Nov., 1922	C. Knudson, Iowa.....	Feb., 1921
L. O. Leura, Illinois.....	Nov., 1922	S. Fulton, Kans.....	Feb., 1921
W. Lawson, New Zealand.....	Nov., 1922	N. F. Hartsoe, Mo.....	Feb., 1921
W. O. Grant, Calif.....	Oct., 1922	I. Qoepra, N. Y.....	Feb., 1921
W. H. Miller, Iowa.....	Oct., 1922	R. E. Worthington, N. Y.....	Feb., 1921
J. S. Lee, Wash.....	Sept., 1922	B. E. Doggett, Kansas.....	Feb., 1921
A. O. Martin, Idaho.....	Sept., 1922	Shellhas & Fry, Colorado.....	Feb., 1921
O. A. Mortimer, Idaho.....	Sept., 1922	J. Toesa, Kansas.....	Feb., 1921
H. J. Hyatt, Washington.....	Sept., 1922	J. W. Wilson, Mo.....	Feb., 1921
J. N. Shaw, Iowa.....	Sept., 1922	W. T. Wilson, Indiana.....	Feb., 1921
A. D. Standford, Washington.....	Sept., 1922	J. Schmid, Nebr.....	Feb., 1921
T. Temkiewicz, Quebec.....	Sept., 1922	E. Sise, New York.....	Feb., 1921
A. Pelifer, Ohio.....	Aug., 1922	A. R. Skerritt, New York.....	Feb., 1921
W. D. Valentine, Iowa.....	Aug., 1922	W. H. Starkey, Kans.....	Feb., 1921
G. Hoffman, N. Y.....	July, 1922	W. Singleton, Pa.....	Feb., 1921
J. Erman, Ark.....	July, 1922	E. N. English, Iowa.....	Jan., 1921
W. K. W. Hansen, Pa.....	June, 1922	H. Becker, Ill.....	Jan., 1921
Robert Tochter, Calif.....	June, 1922	G. Tice, N. J.....	Jan., 1921
J. Van Marter, N. Y.....	June, 1922	J. Briere, Vt.....	Jan., 1921
F. Norrie, Yukon Ty.....	Jan., 1922	A. Bartlett, Vt.....	Jan., 1921
J. Needham, Kans.....	May, 1922	E. H. Manley, Mo.....	Jan., 1921
E. Anders & Son, S. Australia.....	May, 1922	Neufeld & Giesbrecht, Kans.....	Jan., 1921
Louisa Carriage Works, Va.....	May, 1922	F. C. Abbott, Ohio.....	Jan., 1921
S. Smith, Texas.....	Apr., 1922	Weldmeyer & Schaack, Mo.....	Jan., 1921
M. Burke, Ariz.....	Mar., 1922	A. Josephit, Colorado.....	Jan., 1921
J. W. Hodge, N. Y.....	Mar., 1922	C. L. McNail, Mo.....	Jan., 1921
J. W. Haar, La.....	Mar., 1922	A. Turley, Kansas.....	Jan., 1921
D. W. Smith, La.....	Mar., 1922	A. Seidel, Nebr.....	Jan., 1921
D. W. Smith, Rhode Island.....	Mar., 1922	W. Ruple, Pa.....	Jan., 1921
E. A. Dillon, Nev.....	Mar., 1922	N. A. Englund, Iowa.....	Jan., 1921
D. F. Kuster, Washington.....	Mar., 1922	O. Gerhardtstein, Ohio.....	Jan., 1921
V. Vanouret, Wisc.....	Feb., 1922	W. C. Rutter, Illinois.....	Jan., 1921
W. Parker, Mich.....	Feb., 1922	J. L. Jester, Mo.....	Jan., 1921
J. DeGlopper, Mich.....	Feb., 1922	G. A. Modatt, Yukon Ty.....	Jan., 1921
Nordstrom Bro., Kans.....	Feb., 1922	F. Fisher, S. D.....	Jan., 1921
G. F. Johnson, Michigan.....	Feb., 1922	J. W. Ivie, Utah.....	Dec., 1920
J. Schoenberger, Ohio.....	Jan., 1922	O. A. Huff, Pa.....	Dec., 1920
A. Burgett, Pa.....	Jan., 1922	J. T. Rowe, Iowa.....	Dec., 1920
R. H. Keith, Iowa.....	Jan., 1922	W. Parsons, Ontario.....	Dec., 1920
W. Parks, Ohio.....	Jan., 1922	Eisler Brothers, S. Dak.....	Dec., 1920
O. Dannemann, Minn.....	Jan., 1922	J. Krahulec, Illinois.....	Dec., 1920
O. Stenning, S. D.....	Jan., 1922	L. F. Kellbols, Pa.....	Dec., 1920
W. Bisker, Ohio.....	Dec., 1921	F. Markgraf, Minn.....	Dec., 1920
W. Lambertson, N. Y.....	Dec., 1921	S. Wright, New York.....	Dec., 1920
Scheffley & Schmitt, Pa.....	Dec., 1921	T. P. Consodine, Mass.....	Dec., 1920
O. Purry, Kans.....	Dec., 1921	J. D. Fox, Nebr.....	Dec., 1920
E. A. Pierson, Okla.....	Dec., 1921	W. Treener, Washington.....	Dec., 1920
J. Robertson, Scot.....	Dec., 1921	A. G. Palmquist Minn.....	Dec., 1920
J. Lauer, Mo.....	Dec., 1921	J. E. Richards, Pa.....	Dec., 1920
A. Brause, Ohio.....	Dec., 1921	J. Bertelsen, N. S. W. Aust.....	Dec., 1920
B. A. Abbey, Ohio.....	Dec., 1921	G. Sykes, N. S. W. Aust.....	Dec., 1920
J. Ingvarson, Minn.....	Dec., 1921	B. Billing, N. Y.....	Dec., 1920
A. F. Milldostrand, Mich.....	Dec., 1921	W. Obergfell, N. J.....	Nov., 1920
J. H. Teufel, Jr., Ill.....	Dec., 1921	L. F. Smith, Ohio.....	Nov., 1920
R. C. Brown, Mo.....	Dec., 1921	D. Cedore, Illinois.....	Nov., 1920
C. Beyer, N. D.....	Dec., 1921	C. Fransen, New York.....	Nov., 1920
G. Nichols, Okla.....	Dec., 1921	J. Delane, Nebr.....	Nov., 1920
F. H. Jostin, Mass.....	Dec., 1921	J. H. Staates, Mo.....	Nov., 1920
J. B. Scheidler, Indiana.....	Dec., 1921	George P. Wardle, S. D.....	Nov., 1920
J. H. Ickes, Pa.....	Dec., 1921	H. C. Strine, Pa.....	Nov., 1920
E. Willis, Colorado.....	Dec., 1921	C. M. McNap, Mass.....	Nov., 1920
F. Kolarik, Iowa.....	Nov., 1921	J. M. Mates, New York.....	Nov., 1920
A. McNab, Scot.....	Nov., 1921	W. Condon, New York.....	Nov., 1920
J. Delane, Nebr.....	Nov., 1921	F. Strieff, Wis.....	Nov., 1920
A. Marks, N. S. W. Aust.....	Nov., 1921	L. P. Mortensen, Michigan.....	Nov., 1920
O. R. Stevenson, Ill.....	Nov., 1921	A. W. Brennenman, Indiana.....	Nov., 1920
J. Meier, Minn.....	Nov., 1921	J. Gribble, S. Aust.....	Nov., 1920
W. Knouff, Ala.....	Oct., 1921	R. L. Whitfield, N. S. W. Aust.....	Nov., 1920
O. M. Johnson, Miss.....	Oct., 1921	McFarlane & Pratt, S. Africa.....	Oct., 1920
J. K. Glinicki, Mich.....	Sept., 1921	Thomas Scurr, New Zealand.....	Oct., 1920
H. Feldus, Nebr.....	Sept., 1921	W. H. Finlay, New Zealand.....	Oct., 1920
R. Murray, Calif.....	Sept., 1921	J. Hawn, N. J.....	Sept., 1920
A. Hammond, Calif.....	Sept., 1921	C. L. Massey, Ark.....	Sept., 1920
P. Wedel, Kans.....	Sept., 1921	J. Jordan, Cal.....	Sept., 1920
J. Ackerman, Indiana.....	Sept., 1921	J. Jordan, Cal.....	Sept., 1920
A. Harper, Mont.....	Aug., 1921	L. O. Breke, Washington.....	Sept., 1920
L. E. Bonton, Iowa.....	Aug., 1921	R. D. Skimkins, Penna.....	Sept., 1920
J. Watson, S. Africa.....	July, 1921	A. E. Reeve, Mass.....	Sept., 1920
R. Goldschager, S. Afr.....	July, 1921	L. R. Garvin, Ohio.....	Sept., 1920
C. Hammerstram, Minn.....	July, 1921	T. Smart, Mo.....	Sept., 1920
A. S. Pratt, New York.....	July, 1921	O. J. Jensen, Mich.....	Aug., 1920
E. H. Spain, Ariz.....	July, 1921	G. W. Phillips, Utah.....	Aug., 1920
L. H. Strange, Vict., Aust.....	July, 1921	A. C. Wagner, Kans.....	Aug., 1920
W. Urquhart, New Zealand.....	June, 1921	F. Kitowski, Minn.....	July, 1920
W. Voigt, S. Afr.....	June, 1921	I. Davis & Son, Pa.....	July, 1920
J. M. Werl, Pa.....	June, 1921	T. Chittenden, New Zealand.....	July, 1920
F. Toll, New Zeal.....	June, 1921	O. Smith, Pa.....	July, 1920
G. Johnson, Kans.....	May, 1921	F. A. Poole, South Africa.....	July, 1920
S. Budge, New Guinea.....	May, 1921	C. Gibson, Ill.....	July, 1920
H. Baker, Aust.....	May, 1921	H. M. Whitman, Neb.....	July, 1920
F. E. Smith, Vermont.....	May, 1921	The Goldfield Diamond Drilling Co., Victoria, Australia.....	July, 1920
A. J. Hatch, Maine.....	May, 1921	G. M. Robben, Kans.....	July, 1920
W. Cornwell, Pa.....	May, 1921	R. J. J. Rees, S. Australia.....	July, 1920
W. F. Kline, Kansas.....	May, 1921	A. C. Morrell, N. B.....	June, 1920
J. Kirkbride, N. J.....	May, 1921	G. Moran, N. Y.....	June, 1920
T. Holloway, Kans.....	Apr., 1921	H. Forst, Man., Can.....	June, 1920
W. Winget, Vt.....	Apr., 1921		

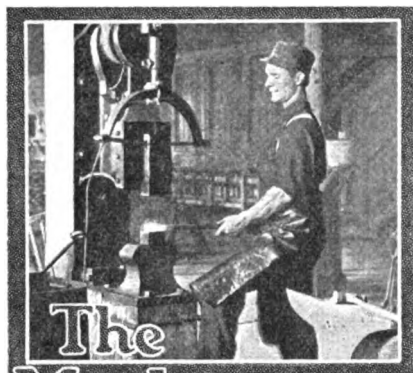

## The Machine and Tool Smith

### Fundamentals of Lathe Practice

Carbon Steel, High Speed Steel and Brass on the Lathe

JAMES STEELMAN

In lathe work, a good deal depends upon the *condition* of the metal upon which cutting operations are going to be carried out. If no attention is paid to this matter, we may very well have as results *unevenness* of cut, a *broken cutting edge* on tool, a *strained lathe*, and it may be something more serious still. Consider, for example, a piece of round-bar steel having a carbon content of, say, 0.85 per cent. This is a tool steel. Under the very best of conditions, the metal will be hard and stiff. It will require greater power to make the same cuts than would steel having a carbon content of 0.50 per cent. Or, if we do not want to increase the power, we may lighten the cut itself.

#### Hard Spots

A piece of 0.85 per cent tool steel may easily not be in the best condition. The carbon—and also other substances that are ordinarily present—may not be distributed evenly throughout the mass. That is to say, we may have 0.70 per cent steel at one point, and close by we may have 1.00 per cent steel. This means a mixture of soft and hard metal, for the reason that carbon makes steel hard—at least until you reach a certain carbon point.

It is ordinarily possible to minimize or eliminate altogether the hard spots in a piece of steel. This possibility is largely due to the fact that carbon shifts its position in steel when the metal is heated to a moderately high temperature.

However, hard places in bars of steel are probably not all of them to be ascribed to excessive amounts

of carbon. We all know that tool steel is especially responsive when very hot to the hardening effects of a chill. Now steel bars and the like are customarily produced by a rolling process. The metal is quite hot to facilitate the rolling. Such a bar may suffer unequal cooling by coming when still very hot, into contact with the floor of the rolling mill. It may even come into more or less contact with water. The hardening which occurs may not go very far. It will not have to go far to make trouble on a lathe.

It so happens that steel is quite responsive to treatments designed to produce a working material as soft as its carbon and other contents permit and as free from hard spots as one could wish. The hardness that goes with the carbon we can not eliminate. In fact, we may not want to eliminate it—it is one of the characteristics of steel having a high tensile strength.

#### Preparing Carbon Tool Steel

The procedure to be adopted is a heat treatment preliminary to putting the work on the lathe. This heat treatment may be loosely called *annealing*. But I venture to think that a proper heat treatment will often involve more than merely annealing. Annealing will, for carbon tool steels, require only a temperature such that a horse-shoe magnet will let go its hold on the steel. This will occur at about *full cherry red* for steel having 0.70 per cent carbon and at a little below this heat for metal having a larger proportion of carbon. Annealing may be defined as the process of restoring by means of heat the normal internal structure of steel. The size of the grains may have been enlarged by a fairly high heat. This condition may be changed back to the size proper to the particular steel by first cooling the steel to some rather low point—*dull red* or lower—and then heating to the point where the magnet ceases to attract. This will be not very far from 1300 or 1350 degrees, Fahrenheit. It may be necessary to keep the metal at this point for a period. We will return to this matter later. Just now, let it suffice to note that annealing of tool steel requires a rather moderate temperature. This process gives us approximately the normal *structure*.

But it does not necessarily give, it would appear, a perfectly even distribution of the carbon. Possibly, a long continued holding of the steel

at the annealing temperature would secure this desirable result. It would seem better to depend upon a higher temperature for a quicker response. In case-hardening mild steel—that is, in producing a high-carbon skin or low-carbon steel—the object is to cause the work to absorb particles of carbon from the bone dust or other substance surrounding it. A temperature rather high is customary in case-hardening—say 1500 or 1550 degrees. This temperature is, however, used with mild steels, as they are the ones which are put under the process. It is possible, then, that a lower temperature might do for tool steels. It will be best, though, to do what we reasonably know will be effective, and heat the steel to the moderately high temperature of *light red* (about 1550 degrees). This will not burn the steel; but it will perhaps enlarge the grain. This condition we may remedy later on by annealing. We hold this temperature for a considerable period. Often, this this will be inconvenient, not to say impracticable, in a smithy. What appears to be a pretty good substitute is this: Heat the steel to as high a point as is safely possible without burning—say to a *light yellow*. This will be about 400 degrees higher than the temperature really desired when we are able to hold the heat for a long time. The steel may now be packed in lime, asbestos or some other good heat insulator. Let the amount be quite considerable; so that it will be possible to envelop the metal in a thick covering on all sides. Leave the whole until the steel has cooled down to a rather low point—say, *dull red* or even lower. This may take a good long while—perhaps in excess of 24 hours; it depends upon the surrounding material, etc.

We may be reasonably certain that inside the block of steel something like this is going on while the high heat lasts. Some of the excess carbon in the high-carbon spots will drift off into the surrounding steel where there is less carbon. This may very well go on until a more or less perfect equalization of the carbon content occurs throughout the mass. This is one of the things we want to effect, preparatory to putting the steel on the lathe.

That time is required may be learned from the experience that has been had with case-hardening. A full day of 24 hours or more is often necessary to get moderate penetration



of the carbon into the steel. No doubt, the very high temperature of light yellow (about 1950 degrees) will hasten matters. At the same time, we are not to expect anything rapid, whatever the conditions.

After this procedure is over and we believe the carbon to be fairly well equalized throughout the steel, we are ready for the annealing proper.

The object in view now is to correct the effects of the high temperature we have been using and perhaps the effects of other high temperatures used previously. The grains are enlarged by such temperatures and this weakens the metal. If the metal is not already fairly cool—dull red or lower—we must let it cool off. This cooling may be done fast or slowly, in so far as the subsequent annealing operation is concerned. But if quick cooling will warp or endanger the piece, we should of course not use it. Perhaps it will be well to follow the rule of always managing the cooling slowly. Then we are fairly sure to be doing the best thing. It may be convenient to know, however, that when the cooling has gotten down to dull red or lower, no harm from anything except sudden contraction will ensue, if we dip the work into water. It is not necessary to cool the work to the ordinary temperature of the atmosphere before going on with the annealing; but it may be desirable, so as to permit handling.

The annealing proper is done by heating to full cherry red (say, 1300

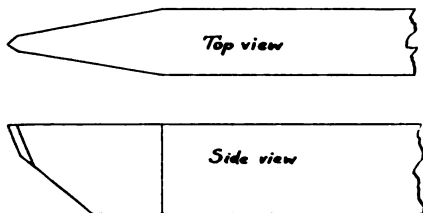

FRONT TOOL FOR BRASS

or 1350 degrees) for the softer tool steels and to a somewhat lower temperature for the harder tool steels, and holding this temperature for a while.

This holding of the temperature may seem inconvenient. It is not recommended to do here as we did before—that is, to heat higher and then pack in lime, asbestos or the like. The reason now is that we are finishing our work. Before, we were expecting to deal with the metal further. If we have no means of

holding the temperature—that is, keeping it steady, allowing it neither to rise nor fall—then perhaps the very best thing to do is to do the final heating very slowly. That is, let the heating from, say, dark red or blood red to the annealing temperature be done at a snail's pace. The object in view is partly to give the interior time to heat up without excessively heating the exterior. We are restoring structure and we are doing it by heat. We can only expect those parts to be restored that have received the heating influence. Consequently, we seek to heat up the inside as well as the outside. At the same time, if the outside is heated too far, we enlarge its grain.

I have now given an account of what to do to prepare carbon tool steel for the lathe—or for the drill or any other machine tool. This is perhaps the most difficult of all ordinary materials that go onto the lathe. Let me briefly state the procedures. First, heat up the tool steel to a light red and hold the temperature for a considerable time. Or, heat the tool steel to a light yellow and pack it in suitable material for a long soak. The second thing is to anneal. Heat the tool steel until the magnet will no longer cling, and hold the heat for a considerable while; or else do the final heating very slowly.

Preparing Medium Carbon Steel

Steel having a moderate degree of carbon—say, 0.50 per cent—will be treated somewhat differently. We may proceed in about the same way as before in so far as the evening up of the distribution of the carbon is concerned. It is in subsequent operations that we alter our course.

The first thing then is to heat the steel up to a light red and hold the heat for a prolonged period, or else to a light yellow. In the latter case, we pack the work immediately in lime, asbestos, or similar material. We then go ahead to anneal, making sure, however, that the work has cooled to a dull red or lower. The work may ordinarily be dumped into water.

The annealing of the 0.50 per cent steel will require carrying it to a temperature somewhat higher than full cherry red, but not so high as light red. This temperature should be held steady. If in doubt as to the length of time, it will be well to hold the temperature longer than a sufficient time. No harm will be done. The alternative to holding the temperature is to heat through

the final stage very slowly, thus giving opportunity for the heat to penetrate. How slowly is a matter that turns on the heaviness of the metal. That is, it will take longer for heat to get to the center of heavy work than it would in the case of small work.

Preparing High Speed Steel

High speed steel may be obtained in bars that have been very thoroughly heat treated by the manufacturer. Such bars will not be much, if any, more difficult to

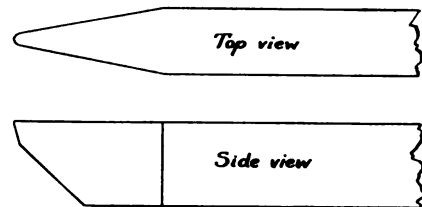

ROUND-NOSE TOOL FOR BRASS

machine on the lathe than bars of ordinary carbon tool steel. On the other hand, the smith may get hold of a bar of unannealed high speed steel or perhaps an unfinished tool or other article that has hardened somewhat and, it may be, unevenly. If, for any reason, the smith thinks the piece he is going to put on the lathe is unannealed, he may sometimes soften it by carefully carrying out the following procedure. But success will not always be his—the method of annealing is too rough and ready. However, here it is.

The piece of high speed steel is heated, very slowly, to a blood red. This heat is held for a while. The work is now left in the fire and the latter allowed to cool. The cooling off of the fire must, if need be, be controlled in such way that it takes place very slowly indeed. Slowness in heating and slowness in cooling—these are very vital things. "If a smith's fire be used, care must be taken to make it deep and to cover it up well after the desired heat is reached, so it will die down very slowly. It is better to build a hood over the fire—and to fill this up with coke before the fire is allowed to go down. If a gas or a coke furnace be used, air must be carefully excluded during the cooling, to prevent excessive oxidation. The heating will occupy anywhere from two hours to ten, according to the size and condition of the piece, and the degree of softness required. The heat must thoroughly and uniformly penetrate the entire piece."

Another Method for High Speed Steel

The heating-up may be done in



the way described. The slow cooling off may then be provided for by packing the work quickly in sand, lime, ashes, asbestos, or the like.

#### A Quick But Less Reliable Method

A third method has been given, but not very highly recommended. The heating is carried only to a *dull black red*, whereupon the work is plunged into water that has been heated to near the boiling point. If the smith experiments with this method, let him see that he doesn't heat the metal beyond the dull black red and that the water is as hot as specified.

The foregoing account of several methods of annealing high speed steel is useful, even if the smith is not going to put the metal on the lathe or under the drill, but is going to forge it to shape. It is, in effect, recommended to use annealed steel under such conditions rather than unannealed.

#### Blow Holes

Blow holes occur in steel castings and may give trouble on the lathe, because of a sudden encounter with the cutting edge of the tool. About all that the smith can do is to be on the look-out. Cast-iron is not liable to blow holes.

(To be Continued)

## The Oxy-Acetylene Plant—2

It's Installation, Operation, and Torch Manipulation

DAVID BAXTER

#### Installation and Care

The installing and care of an oxy-acetylene welding apparatus is nearly as important as the operating and demands the same careful attention, if one is to secure the most economical results; yet the average purchaser pays but little attention to its installation—in fact most of them are placed in some unhandy corner of the machine or blacksmith shop.

The ideal way, perhaps, is to provide a special building which may be a but a small, neat shack, or a separate room, either of which should be well ventilated and lighted. This enables the operator to do better work and keeps the air free from both the welding gas and other gases caused by burning flux, coke fires, burning grease, oxide of zinc, and so forth.

Good light enables the operator to read his regulators and gauges at a glance. The isolation frees him from the bother and interruption of visitors or fellow workmen near him or passing by his work. When an

operator begins a difficult piece of work, he should be allowed to concentrate his mind upon the work at hand and the welding machine, not on answering the questions of curious visitors.

The generator, or gas tanks, should not be placed close to the wall, but should allow room for a passageway between them and around them.

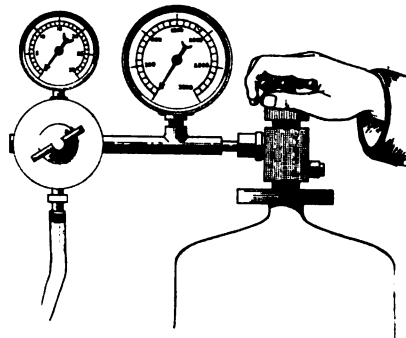

ALLOW ROOM TO STAND BEHIND THE OXYGEN TANK

This is of two-fold benefit; it facilitates inspection on all sides, and gives enough space for one to pass the operator without detracting his attention or accidentally bumping the regulators which might change the pressure. It also prevents tripping over and walking on the hose.

Examine the generator tanks and fittings for signs of corrosion, using a scraper to determine if there is danger of or liability of the pipe connections being "eaten" off by the chemical action of the contents of the generators. Take no chances: if you think a thin spot is appearing repair it with out delay. Let us again repeat: "Safety First."

It is not a costly arrangement to have the hose suspended overhead, especially where the weld is located some distance from the generator. Then we know that no one is going to trip over the hose and perhaps provoke a fire or explosion thereby.

The ventilation should be so arranged as to permit plenty of fresh air without drafts of air passing through the room, and particularly these drafts should not strike the casting being welded or cooled. Close the openings on the side from which the wind comes. During winter avoid opening and closing doors while an operator is working on complex job. The sudden puffs of cold air are the ones that harm the weld. Blasts of cold air cause the expansion and contraction to fluctuate rapidly. Suppose the operator is just finishing welding an auto engine cylinder and someone opens a door

allowing a blast of cold air to blow directly upon the cylinder; the cold blast will cause the metal to cool so much faster than is normal, that a strain is set up causing a crack some where near the weld. Endeavor to keep an even temperature in the welding room. All this may sound like going to extremes in carefulness, but it is only proper caution. And the successful welder always observes these little points.

It is good practice to have the generator located so that several different welding jobs can be reached at the same time. This is real economy during a rush spell. One may then be welding one job while another is cooling and still another is preheating. This is an economical arrangement even with the ordinary run of work.

Wherever possible, it effects a great saving to have a sewage system for convenience and cleanliness in handling carbide residuum. Where there is a considerable quantity of this residue, it is possible to sell it. It is very valuable for such purposes as whitewash, fertilizer, mixing mortar, and treating walls and roads. Sink a tank out-of-doors to drain the tanks into, with facilities for pumping or dipping the residuum out when it is hauled away or used. It is said that certain scientists are developing a method of generating oxygen gas similar to the method of generating acetylene: by dropping lumps or cakes of some sort of substance into water. But as no one is using such a method yet, no sewage system is necessary for the oxygen residue. Of course, those who have installed the oxygen generator should have a means of taking care of the chemicals and the ash.

For those using drums, no preparation is needed for caring for the residue because the drums contain nothing but oxygen gas. As this is the universal way of using oxygen it is well to remind the operator to have a cool, clean, dry place to store the extra drums he may have on hand. Also he should have a special truck or other handy way to move the drums about when taking out an empty one or connecting up another loaded one.

There should be a locker or some other safe, dry place to store the carbide and other chemicals and also, the new metal fillers. This should be arranged to secure the greatest economy of time. The time it takes to go the length of a large building



after supplies, has to be charged to some one's work and it is not fair to charge it all to one man.

Any dust, rust, or grease adhering to the filler rods may give trouble in the weld. So if for this reason alone, one should have separate bins for the fillers and fluxes.

Any leakage of acetylene may be detected by its nauseating odor. All ignition by leakage, carelessness, or faulty handling is not seriously dangerous if the valve of the oxygen cylinder is immediately closed, also the cock for the admission of the acetylene to the welding place. In event of a leak in the acetylene apparatus, put out all fire within six feet of the plant until the leak is repaired. If the leakage occurs in the hose or connections, shut off the gas at the generator valve before attempting to repair the break.

Oxygen leakage will create a fire if a spark from the fire strikes some inflammable substance, such as oily waste or greasy clothing; therefore it is best to avoid having any inflammables near the oxygen cylinder. Keep all rubbish away from the welding plant, such as excelsior, paper, and oily rags. Put it in the fuel locker—don't pile it up in the welding room. While oxygen will not burn alone, it will cause a fire to burn fiercely. As an extra precaution, remember that if oxygen contains hydrogen to a great extent, it would form an explosive mixture.

When oxygen comes in contact with oil it usually results in an explosion, if the oxygen is under pressure, and more readily if the gas has a certain movement or velocity. The simple contact of oxygen with oil will not always result in an explosion, but it is best to be on the safe side, and not place the cylinder under an oily line-shaft, or where oil will be likely to drip or spatter upon it. This means any kind of oil. White lead has been known to cause a violent explosion. The point is this: never use oil or grease on the connections or regulators of the oxygen apparatus; read the instructions accompanying the loaded drums and follow them to the letter. If the threads do not work easily, get a new connection, don't take any chances by greasing the threads. *"An ounce of prevention is worth a pound of cure."*

In the installation of a welding plant it must not be misunderstood, when we say plenty of ventilation, that the welding room should be all

air-holes winter and summer, because there is great danger of the water freezing in the generator chamber. Therefore, it must be understood that the room should be sufficiently heated to keep away the frost. At night, be careful to drain the tanks or leave an all-night fire at a safe distance from the plant. A warm room will be of value in another way; the operator can do better work if his hands and feet are warm instead of numb with cold.

An ideal method of ventilating is to have fresh air coming from some

which will come in handy almost every time the outfit is used.

The welding table is almost indispensable. The author would suggest a table about thirty inches high and three feet across, either round or square, built of angle iron, not having a top, but arranged so that a loose grating may be placed across the table, with the ends resting on the inside of the angle-iron. This may be simply slats of iron on which is placed a layer of firebricks, or they may be cast grates. The frame of the table should be strongly built, and would be better if the top

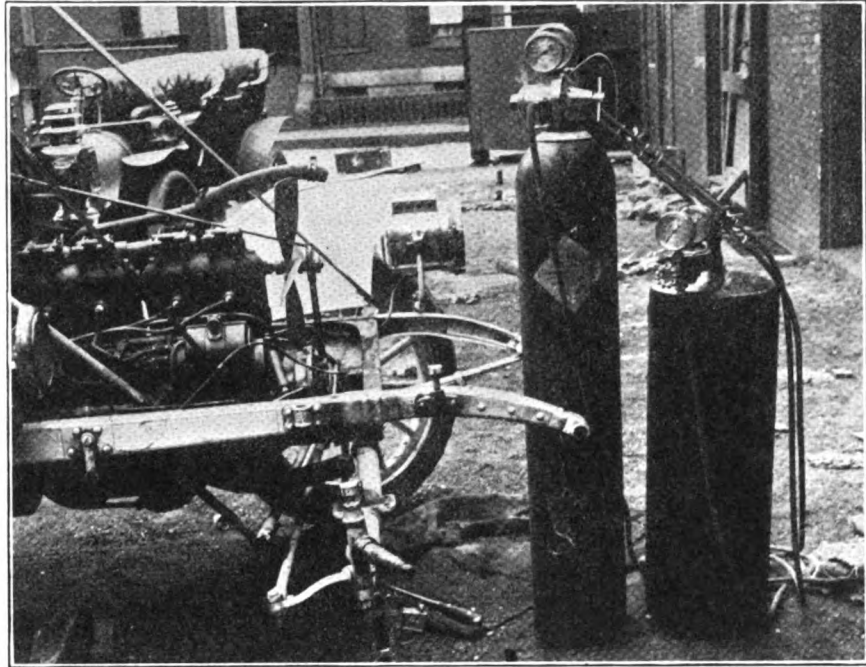

A PORTABLE PLANT EASILY TAKES CARE OF JOBS OF THIS KIND

place in the floor and passing out through some place in the roof.

We might well include taking care of the tools and other equipment of the welding apparatus and welding shop. Have a special place to keep the torch and extra tips and wrench. When through welding do not leave the torch and hose lying around on the floor—hang them up. Keep them clean; also the tips. It takes but little time to do these things and will certainly repay us in the time it saves in hunting little things.

#### Accessories

In doing a general repair business with an oxy-acetylene welder, it will be found that a number of devices for moving, clearing, clamping, preparing and finishing the work are necessary. Some of these may be purchased ready-made, and others may be easily made at home. By using a little ingenuity one can construct clamping and leveling devices

were mounted to allow it to tilt up on either side; this would admit the welded casting to be tipped or moved without loosening the clamps.

For instance; suppose we were welding a cracked and broken crank case which was broken along the flange, and the crack extended up over the round shoulder. And we had the case clamped upon a leveling plate on the table. We would weld the broken piece and without stopping to shift the case would merely tilt the table, thus turning the job slowly and welding the line of the crack up over the shoulder without shutting off the torch. Besides saving the time of unclamping and reclamping, we would not risk losing heat and cracking the weld.

The whole table should be mounted on a round turntable imbedded into the floor, which should be easily movable, and have a locking device. There should be more than one gas,





oil, or gasoline torch, so arranged as to swing to any part of the table underneath the grating. This may be readily arranged by the use of sleeves or slip-joints or hose.

With this arrangement, several small jobs may be preheated at once, or one large one preheated in several places without moving; and, with the above described table, the operator may swing the job around to him as he works saving considerable time. Numerous small jobs may be welded and cooled on the table without preheating, such as small wheels, stove legs, pump handles, and small farm machinery repairs.

Preheating ovens may be used for preheating, slow-cooling, and annealing welds. They may be made in two general kinds, either where the oven is placed over the casting, or where the casting to be heated is run into a stationary oven on metal trucks. The latter is similar to a core-oven in a foundry and is built of brick, or some like material. They may be fired with either, oil, gas, coke or charcoal. The movable oven should be made as near a non-conductor of heat as possible.

The portable oven should be so arranged that it is quickly and easily movable. If small it should have asbestos padded handles for grasping and moving quickly. If too large to move by hand, it should have balance weights or an overhead trolley to offset the weight. With a bunglesome oven we may lose a good weld by not covering the casting quickly enough.

Suitable methods for easily handling heavy castings should be present in every welding shop. An overhead trolley is very handy and inexpensive. It need not be power-driven, but can be arranged with chain blocks, and should be to serve the welding table, the preheating ovens, and for loading and unloading at the shop door. A portable steel hoist will serve in absence of a trolley. A useful article about the shop is a torch lighter. This may be either an oil torch or a small gas jet placed where it is within easy reach of the operator. It will pay for the fuel consumed many times over in the time it saves from relighting the torch.

In every shop should be at least an emery-grinder, forge, anvil, vise, hammers, files and other small tools for finishing the jobs. Where there is a machine shop in connection the work may be finished therein.

#### Supplies

A full line of welding supplies should always be kept on hand, because the general repair shop is called upon to do a great variety of different kinds of work. The supplies include the filling-rods of all kinds of metal, ranging from one-sixteenth of an inch in diameter up to three-eighths inch, and up to twenty inches long. Although the larger sizes are often used it is often better to twist two or more small ones together and use them that way when we have a heavy weld to make, as it will melt and fill easier without danger of burning.

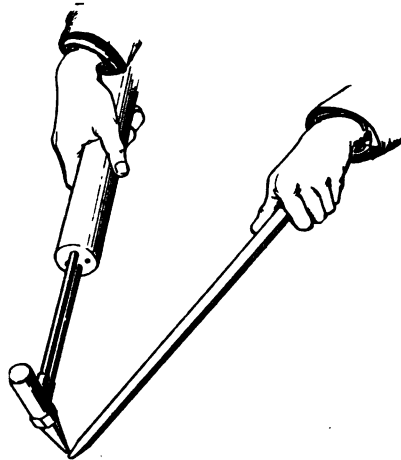

FILLING RODS OF ALL KINDS OF METAL ARE NEEDED

Short pieces should be saved and tackled together to form longer sticks. By tacking is meant, welded together with the torch. Thus none of the filler is wasted; we can always fasten the short pieces to longer ones. When welding in corners it is often inconvenient to use a long stick of filler; it is also hard to use the short pieces as they get too hot to hold, even with gloves. To overcome this difficulty we can use a pair of pliers, if we wrap the handles with asbestos fastened with electrician's tape.

The different grades and kinds of metals should be kept separate, and labeled plainly with name and characteristics. A rack of pigeon-holes may be cheaply made which will prove doubly useful if mounted on wheels or castors. It will then save many steps during the day, by being wheeled from job to job.

Supply fluxes for the different metals. It has been proved that while the flux does not make the weld, it is an indispensable aid. They should be tabulated and kept in a clean dry place.

There should be on hand a supply of charcoal, coke and other fuel for preheating and annealing.

A bolt of asbestos paper should

be on hand to cover up castings when slow-cooling. It is also used as a protection when welding and as a non-conductor of heat. Save the scraps, for they are as handy as the paper itself. Have a sheet-iron box of about three by five feet square by two and one half feet deep. This is a convenient size to accommodate most jobs that do not need preheating. Put all scraps of asbestos paper in this box; when it is nearly full it makes one of the best means of slow-cooling. The welded casting is buried in the scrap paper with the assurance that it will cool very slowly thus insuring the casting against cracking. The asbestos scraps soon crumble to small particles which makes it an easy matter to pack it around the casting.

Another handy contrivance for small castings is an iron box or can filled with smooth sand. But be sure the sand is hot before burying the casting in it.

It is a good idea to learn the melting temperature of metals and filling-rods; put this information in the tabulation. The supply houses will furnish such information upon inquiry. If we know the melting temperature of the metals and fillers, we can more readily judge the size and kind of filler to use on the different welds. For instance, if we are welding an aluminum crankcase we should know that the metal in the case contains a certain percentage of zinc. Zinc burns out very easily so we must choose a filler having a higher percentage of zinc to replace the zinc burned out of the casting. The burning zinc may be detected by the white specks floating away from the weld.

It is opportune to suggest here that the operator have a book and keep a close record of all jobs as he meets them. He can refer to this book on future jobs of similar nature. If a record of everything is kept it is a simple matter to estimate quickly and accurately costs on any job.

*(To be Continued)*

#### Tire Vulcanizing Now Taught in Public Schools

Some of the pupils enrolled in the vocational-training classes of the Cincinnati public schools are being taught to repair the tires of their fathers' motor cars. Not long ago an automobile concern loaned some of its equipment to the schools with the result that a thorough course in tire vulcanizing and repair has been established. The work, as one might well imagine, appeals to a large percentage of the boys and therefore the course is a popular one. Parents and teachers are taking advantage of the opportunity to have tires mended cheaply.



## Smithing Prices and the Nebraska Organization

Mr. C. C. Good, Secretary of the Nebraska Blacksmiths, Horseshoers and Wheelwrights Association has sent us an account of some of their "doings" at the last big Hastings Convention, and it surely does make us wish that we too could have been present to listen to the enthusiastic discussions of present-day, smith-shop problems.

The question of prices seems to have occupied much of the time, and evidently received careful and thorough attention—if we are to judge from the revisions made in their old price list.

We are printing extracts from the new one, and it furnishes an interesting comparison with its predecessor which appeared in our December 1916 issue.

Perhaps readers will recall Mr. Bert J. Story's remarks about the old Nebraska Price List, in his article on "Shoeing Prices vs. General Smith Prices". He stated that the Nebraska prices seemed unusually low, and asked "Why don't they charge living prices?"

Of course prices are not the same in all sections, and in some localities blacksmiths really can afford to get along on comparatively lower prices than is possible in other sections. Some places have been fortunate in being supplied with material purchased well in advance of the present rise in prices. We do not know whether this was the case with the Nebraska Association; at any rate they are now feeling the effect of present conditions and their prices have been raised accordingly.

The following is their new price list, which has been in effect since the Hastings Convention:

<b>Wagon Wood Work</b>	
New pole complete	\$7.00
New axle	5.00
New bolster, old irons	3.00
New sandboard	2.50
Bent hounds, old irons	5.00
Hind hounds, old irons, each	1.75
Tongue put in old irons	4.00
Bolster stakes, old irons	.75
Cutting down wagons, 1½x2¼, 10. to 12.00	
New rim and setting tires	3.00
Half rim and setting tires	2.00
Sawed felloes, each 40c; 3 for	1.10
Spokes, straight 35c; 3 for	1.00
New hub in wheel 2.50; wood work	2.00
Wagon reach	2.00 to 2.50
<b>Wagon Iron Work</b>	
Setting wagon tire, each	.75
Setting wagon tire, a set of four \$2.50, bolted	3.00
Setting 3-inch tires; \$4.00; 4-inch tires	5.00
Hub band, each	.40
New wagon tires, besides piece of material, each	2.00

<b>Carriage and Buggy Wood Work</b>	
Replace broken buggy tongue	\$.40 to 4.50
New buggy tongue complete	8.50
New side in shaft, each	2.00 to 2.50
New cross bar in shaft	1.50
New spoke	.35
New buggy reach, straight	1.25
New buggy reach, bent	1.75
New buggy evener, painted	1.25
Putting half rim in wheel, setting tire	2.00
Straight pole cross piece	1.50
Neck yoke, wood put in	1.00
Axle beds	2.00
Spring bars	1.50
Head blocks	2.00
Spring wagon pole complete	8.00
Spring wagon seat complete	4.00
Spring wagon box complete	15.00

<b>Carriage and Buggy Iron Work</b>	
New axle stubs, fifteen-sixteenths \$10.00; 11-8 \$10.65; 1¼, \$11.90; 1¾	\$12.50 and up
The above is for common half patent Axles.	
Straighten buggy axle	1.25
1 new stub and boxing in wheels	3.15
Welding spring leaf	1.10
New rim on buggy wheel, set tire 2.75 to	3.25
New fifth wheel	3.50 and up
Set buggy tire, each 75c, set	3.00
Set wheel dishd wrong	1.25
Buggy tire, beside price of material, per set	6.25

<b>Plow Work</b>	
New lay, 14-inch	\$4.00
Sharpening 12-inch lay 40c each, two for	.75
Point and sharpen lay, 14-in., \$1.40; 16-in., \$1.50; 18-in.,	1.75
Point and sharpen lister 14-in., \$1.60; 16-in.,	1.75
Repainting and sharpening shovels, 4 in set	3.00
Polishing rust, per set of 4, \$1.00 to 1.25	
Sharpen set of four shovels	.75
Straighten gang ploy beam, each	1.50
Straighten walking plow beam	.75c and up

<b>Horse Shoeing</b>	
4 New Shoes (up to No. 6 and including No. 6)	2.50
4 New Shoes (No. 7)	\$2.75
4 Shoes, Reset (up to No. 5 and including No. 5)	1.40
4 Shoes, Reset (No. 6 and No. 7)	1.50
4 Neverslip (up to No. 5 and including No. 5)	3.00
4 Neverslip Shoes (No. 6 and No. 7)	3.50
I Bar shoe (up to No. 4 and including Neverslip Calks, each	.07½
1 Bar Shoe (up to No. 4 and including No. 4)	1.25
4 New shoes on heavy stallion	6.00
4 Shoes reset	4.50
Putting horse in stokes or roping extra each foot	.35
Shoeing under veterinary, extra per hour	.50

<b>Miscellaneous</b>	
New mower tongue, fir \$4.00, oak	\$5.00
Sharpening road grader blade	3.50 to 4.00 to 5.00
Repairing scraper bail	1.00
Sharpening road plow	.75
Sharpening coultter	.50
Pointing and sharpening road plow	2.00
Putting in fork, scoop and ax handles, each 25 and	.35
Sharpening stalk cutter blades, straight 25c, crooked	.35
Setting tires on Manure spreader, front \$2.00, rear	2.50
All prices are regular sizes. Extra for heavy jobs.	

Labor by the hour means time only. Charges to be for all material and stock used.

First hour, \$1.00; after 65c. Extra charges for helpers work. Helpers 15c per hour profit on his labor. Breakage, destroying or losing tools to be charged to help unless unavoidable, or any person borrowing tools.

When using Power. Labor and use of machine is worth \$1.00 per hour.

On all odd jobs, weigh the iron. Charge retail price per lb., for the iron.

Charge up all Bolts and Rivets, Retail price.

Time on all dirty jobs, such as automobile, mowers, wagon and all jobs that have grease, dirt, etc., commence when you go to work and should be charged for till the tools are cleaned and put away and your hands washed to give you a chance to make change.

All book accounts are due every thirty days unless other arrangements are made.

Any person not paying bills within 60 days will be charged for filing lien for work done.

Mr. Good tells us about some of the topics discussed, and we note with interest that all of them met with an enthusiastic reception:

- "The Passing of the Horse."
- "Should Blacksmiths Repair Automobiles and Tractors."
- "The Location of Blacksmith Shops in Undesirable Places."
- "Oxy-Acetylene Welding."
- "The Use of Power in the Shop."
- "Prices."

"Accounts—Their Keeping and Collection of."

"Organization of Blacksmiths to Promote Friendly Relations—Particularly among those Doing Business in the Same Town."

The consideration of such subjects certainly reveals an organization or real purpose made up of live-wire members of the craft. If smiths all over the world got together in such community groups for the mutual and serious discussion of these topics, what a change would be wrought in the business! They are doing it in many sections—some through state-wide organizations, such as that of the Nebraska Association; others through county organization. It is in keeping with the fine spirit of co-operation and brotherhood which is having such a telling effect upon all the trades and professions these days. Even if only a few members of the craft in each community could meet once in a while, doing away with all antagonism and "cut-throating", it would mean not only money in their pockets, through better prices, but would give all a bigger sense of their worth and a keener pride in their profession, as brothers of the "noblest craft."



## How to Hammer Circular Saws\*

The tools required are two straight edges, one from 14 to 18 inches long, and another about 48 inches long; one try-mandrel; one round-face and one cross-face hammer and an anvil.

By placing the straight edge on the saw when laid on the anvil, it can easily be seen if tension is lost. The saw should be tested all around to see if any part between the edges and the center falls away. Such spots should be marked and should not be hammered as much as other parts, if at all. In testing for the tension be sure to have the straight edge crossing the saw diametrically from that point of the saw that rests on the board, the opposite edge being raised by the left hand, while the straight edge is held and gently pressed down with the right hand. Do not lean the straight edge to one side but hold it up straight, or it will fall to the form of the saw and not show what is desired. A straight edge reaching from the center hole well out to the edge of the saw is the best to use in hammering to regulate the tension, and when this straight edge is applied as above the saw should fall away from a straight line; this will show that the center of the saw is stiff.

It is very seldom necessary to hammer a saw at the part covered

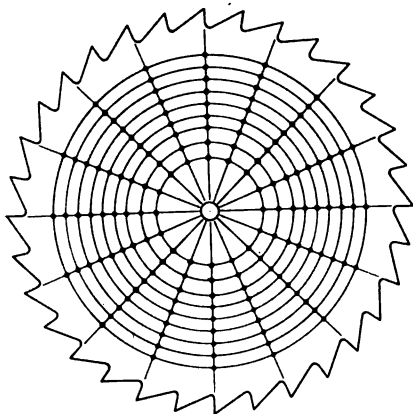

HAMMER AS INDICATED BY THE DOTS

by the collar. When commencing to hammer see that the face of the hammer is ground so that the blow will be round, and do not strike too heavy, for it is better to go over the saw a number of times than to hammer too much at one operation and thus put the saw in worse shape than it was before starting the hammering.

\*Reprinted by request.

The hammering should occur at the points indicated by the dots in the engraving. After going around on one side mark off the other side and repeat the operation with as nearly as possible the same number and weight of blows as struck on the first side and as directly over them as possible. Now stand the saw on the floor; hold it up straight and test it with the long straight edge. If the hammering has been done alike on both sides the saw will be very nearly true. If, however, it shows full on one side and dishing on the other, mark the places that are full.

Place the saw on the anvil with the round side up; hammer lightly on full places; test again with the long straight edge, and if it appears true, put it on the anvil to see if it has the proper tension; if not, repeat the operation with the round-face hammer. When it has been regulated to the proper tension the most difficult part of hammering will have been accomplished.

Next put the saw on the dry mandrel and test it with the short straight edge for running true. Mark the places as they run on or off while turning the saw slowly around. Where the saw runs off the lumps must be taken out with a cross-face hammer and struck in the direction that the straight edges shows the lumps to run. The saw may also be thrown out of true by lumps running toward the center. In this case the saw will be on or off at points about opposite each other. If this part of the hammering is of the proper weight and the face of the hammer properly ground the saw can be made to run true without altering the tension to any extent.

The testing on the mandrel should be with the full side of the saw towards the pointer, and by knocking down the lumps from that side the plate will be made flat. When the saw is fairly flat test it from both sides. Next put the saw on the arbor, and if to be run at high speed it will sway gently from side to side in getting up to full speed and may then run steadily and do its work. If it does not, but rattles in the guides, it needs to be made more open toward the center. An experienced man can stand the saw on the floor and by giving it a sudden shake at the top edge will know it is open toward the center if the center vibrates and the edge stands stiff. If the saw should be buckled by an acci-

dent, true it with the cross-face hammer before regulating the tension and final truing. Do the same in case of buckling caused by burned spots or sharp limps over the collar line. These may be knocked down by placing two thicknesses of strong, heavy paper on the anvil, when, by a few well-directed blows the limps can be hammered without expanding the metal to the same extent as if straightened on the bare face of the anvil. It is very important to have the blows distributed properly over the surface to be hammered. Hammering too much at one place causes a loose spot or lump that will be difficult to take out. In hammering with the round-face hammer work on lines drawn from the edge toward the center. This will prevent putting twist lumps in the saw and obviate much of the trouble in truing with the cross-face hammer.

If it is necessary to go over the hammering more than once for tension do so on lines between those that have already been operated on. The round-face hammer should have its face so dressed that a light blow would show about one half an inch in diameter; while the cross-face should show a blow three quarters by three eights inch. A sharp, cutting blow from the hammer is not effective in either knocking down a lump or stretching the metal.

It is always advisable for beginners to start in with a small, circular handled, and to practice on this until expert.

### Spark From Man's Body Causes Garage Fire

When a resident of Dubuque, Iowa, wearing a fur coat and rubber boots, walked hurriedly to his garage on a cold morning recently, he did not realize that his movements were storing up a dangerous amount of electricity in his body. But the fact was that the friction of his arms against the coat caused a certain amount of static electricity to be generated, and this was stored in the man's body because it was insulated from the ground by his rubber boots. When he sought to prime the motor of his car with a mixture of gasoline and ether, using a metal squirt can—probably of copper, which is a good conductor of electric current—the can was brought so close to the motor that a spark was produced between it and the priming cup, igniting the gasoline. The can exploded, throwing the flaming liquid over both man and car. The man escaped with severe burns, but the car and garage were completely destroyed.

A clay pipe may be used as a crucible for melting small quantities of metal. The stem is broken off and a plug fitted into it.



### Blacksmith a Jolly Dog

A letter from the trenches brings this interesting bit of information to us:

"We ran across a blacksmith a couple of months ago who was one of the most congenial fellows you ever met. He had his shop right beside one of the main roads used by the troops in going back and forth to the trenches and he always had a stock of wine and something to eat. His shop did not keep him very busy, and he was nearly always at his door. He would talk to the soldiers, give them a drink, ask where they were going and want to know how long they would be gone, so that he would be waiting to give them another glass of wine when they came back. He was very popular with the soldiers because he was such a good fellow, always ready with a joke and a glass of wine.

"But our concentrations were known to the enemy. Our men were being shot down. Some of our spy catchers got to work to find the leak. They hunted through the sector for the best place to pick up news about troop movements, and they found of course, that all the soldiers were friendly with the blacksmith. His shop was raided one day. He had been left behind by the Germans. He had a three month's store of wine and food in his cellar. He had also direct telephonic communication from his cellar with the German lines. He was shot."

### A Noiseless Anvil

An exchange suggests this arrangement to rig up a serviceable and almost noiseless anvil.

Briefly, it is simply an I-beam fitted with a wooden casing as shown in the accompanying illustration.

Details of its construction are as follows: a section of an I-beam, which can be picked almost anywhere, is sawed into a short length of 2 feet, squared at the ends and all rough edges filed off. Two holes for bolts are then drilled about six inches from each end.

Oak or other strong wood serves as the block. This is made from two pieces, the inner faces being cut to fit the flanges of the beam tightly as shown.

A pad of leather is fitted under the beam at "A" and the parts are bolted firmly together.

All parts must fit snug and the bolts well tightened up. There will then be very little noise produced when this home-made anvil is used.

With a little ingenuity a section of a railroad rail or other piece of iron could be substituted, keeping in mind, however, that all parts are to be bolted together firmly in order to make it practically noiseless.



## Benton's Recipe Book

Another way to make an old file cut—When a file has seen its best days and refuses to cut, try this little kink: Take a piece of charcoal and rub on the file, just one or two strokes, and then try your file. You will find that it cuts much better, and will not clog with filings.

To keep oil stone sharp, particularly at the corners, and the surface of the stone flat, Benton suggests this method. Have at hand a planed cast-iron plate on which to true the stone by sprinkling powdered carborundum over the surface of the plate and lapping or rubbing the stone to a bat surface.

This rapidly trues the stone and also sharpens it and improves its cutting quality by the fact that it becomes charged with carborundum which is forced into the pores of the stone.

A harder stone may be used when it is kept sharp with carborundum than is otherwise the case.

Proper lubricants for machine work seems to puzzle a Missouri reader, and we offer the following: For lathe centers there is nothing quite equal to white lead mixed with sperm oil, with enough graphite added to give it a dark lead color. It can be mixed and kept in small tin boxes; add oil when necessary to keep it from getting too thick.

For cutting bolts and tapping nuts, try this excellent solution: Dissolve 1½ pound of sal-soda in 3 gallons of warm water, then adding 1 gallon of pure lard oil. This is known as a soda solution. Pure lard oil is the best for fine, true work. Never use mineral oils in thread cutting and tapping, as they do not generally flow freely enough.

For cutting tools, particularly in the large shops, the following lubricant mixture is good: Use 6 gallons of water, 3½ pounds of soft soap, and ¼ gallon of clean refuse oil. Heat the water and mix with the soap, preferably in a mechanical mixer; afterwards add the oil. A cast iron circular tank to hold 12 gallons, fitted with a tap at the bottom and having three revolving arms fitted to a vertical shaft driven by bevels and a fast loose pulley, answers all that is required for a mixer. This should be kept running all through the working day.

A lubricant for the threads on large pipe fittings can be made up of one-half pint black machine oil, 2 ounces white lead, 8 ounces graphite, and about half a teaspoonful of flour of emery. The emery will smooth the threads, and the oil and lead will make a fine lubricant of enough body to stop any leak.

How to turn aluminum to produce a smooth surface, has G. H. L. stumped, we think this scrap of advice will help him—Use kerosene oil for a lubricant. If

turning in a turret lathe provided with an oil pump, mix the kerosene oil with lard oil, 1 part of lard oil to 3 parts of kerosene, as kerosene itself is too thin to be fed through the ordinary oil pump without being mixed with a more heavy flowing fluid. Kerosene oil is also the best lubricant for use in boring, threading and reaming aluminum.

With spring cleaning ahead, the following recipe for whitewash should prove useful: Dump a half bushel of quick lime into a good tight barrel. Add enough water to cover it to the depth of 6 inches and cover the barrel to keep in the steam. When the boiling is finished, add water to make it the consistency of cream and add two pounds of sulphate of zinc and one pound of common table salt. Now add enough water to make the mixture spread easily with a paint brush, and after stirring thoroughly, apply to the interior shop walls and ceiling.

The neatness and added attractiveness will help to draw trade your way, and show you up as a real live member of the craft.

Squeaking springs are usually due to the working of the leaves upon each other, and can be remedied in a very easy manner. Jack up the body of the car so that the weight is off the spring, and then introduce between the leaves a mixture of flake graphite in a light oil or kerosene. The oil serves to float the graphite to the place where it will do the most good, and the small particles of the graphite become

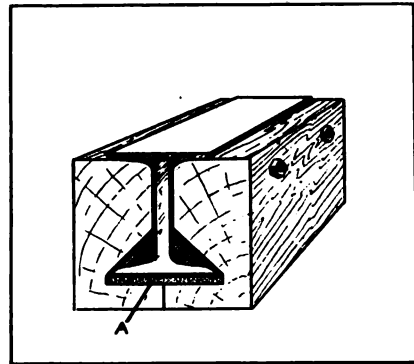

HOW THE NOISELESS ANVIL WAS BUILT

imbedded in the rough surfaces of the leaves and usually effect a permanent relief.

This kink is a good one to keep in mind when overhauling or repairing an automobile.

Removing paint from wood, is a problem which every vehicle worker faces only too frequently for his peace of mind. Some very satisfactory paint removers can be made by mixing up proportions of such substances as acetone, amyl alcohol, carbon bisulphide and ethane tetrachloride. Any one of these liquids will suffice and may be applied with a brush or made up in paste form and applied with a pad. A good preparation may also be had by mixing together ½ lb. of potassium hydroxide, 1 pt. of acetone, ½ pt. each of methylated spirit, oil of turpentine, petroleum spirit and 5 oz. castor oil. A thin coat of this is spread over the paint surface and a few minutes later another application is made. This will soften the paint so that it can be removed with a scraper or spatula.



## Queries— Answers— Notes

**Answers the Kentucky Smith**—I think no horseshoer or blacksmith who is interested in the craft should be without *The American Blacksmith*; one gets so much good stuff out of it for so little money.

I see on page 128 that a Kentucky Smith asks if some brother blacksmith could tell him how to stop a forging horse. Well it's a hard job to stop a horse with a short body and long legs; but you can stop a horse that plugs in the toe, by simply scooping the toe out and putting a calk on each side of the toe to quicken his action. But if he hits the side of the shoe, you would have to know where he hits in order to know how to stop him. If the Kentucky smith is interested, and if he will write me and tell me horse's gait, I will tell him the best way to shoe that horse. All forging horses can not be shod alike; for that reason I would like to know the horse's gait and where he strikes the front shoe.

LEWIS STRODDAD, Yarmouth, Nova Scotia, Canada.

**Hardens High Speed Steel Tools in Water**—I always look for the *American Blacksmith* with great interest. The article in the February number on the experiments of High Speed Steel tools interested me very much, and I am going to try some of them out. I have also been experimenting on lathe tools, hardening them in water and have met with the greatest success. Manufacturers of these steels tell us not to put them in water, but it can be done. The whole secret lies in the way they are dipped; and a tool so dipped will last easily from three to five times as long as a tool hardened in Oil or Air. I have never had a tool crack through hardening it in water, so if you know of any one interested who would like to try out my method I will be pleased to tell him. Address  
S. S. CURRIS, Hamilton, Ont. Canada.

**Drawing the Temper in Small Taps and Reamers**—Can you tell me how to draw the temper in small taps and reamers successfully? I have trouble with the shanks breaking when the cutting edge is all right.

J. R. ROWLEY, Pennsylvania.

**In Reply**—The proper way to hold a tap or reamer in drawing the temper is with the threaded, or fluted, end in a round pair of tongs, the squared end to the flame. Draw the tool to the proper degree at the point. When drawn to the proper color, quench it in oil or luke-

warm water. This gives the cutting part of the tool the hardness necessary for standing up under the cut, and the shank the strength and toughness necessary to prevent breaking. For tapping cast iron, draw to a light straw, and for steel, to a light brown.

P. S. New York.

**Wants to Know how to Harden Motor Vehicle Springs.** Will you kindly tell me through the columns of the *American Blacksmith* the best way to harden and temper all kinds of motor vehicle springs?

YORKEY, England.

**Editor's note:** This is a question that should interest all members of the craft who are taking up automobile work. Some have already experimented along these lines and we would welcome descriptions of their methods for publication in this column. So if you have any ideas on the subject, sit right down and write them out. This is the reader's paper—to express his ideas, as well as to read about those of his fellow members of the craft.

**The Blacksmith Business in Texas and Oklahoma**—For the first time, will send you a few of my ideas of the blacksmith business as it is conducted in Texas and Oklahoma. I believe at least 90% of the men who wield the hammer are failures. First, lack of education, second lack of organization, and third, drink. With the above, system is an unknown quantity. Guess work and no prices, credit to all classes, bad collections and busted merchant is the finish. The 10% possibly, that do succeed have done it under the worst conditions imaginable, and if ever mortal man will be crowned, the one that raises a family, buys a home, and pays for it, blacksmithing surely can't miss it. The auto has come to stay I think, and in coming will revolutionize the trade. Tell us more about business management of shop; shoeing horses is fast going. Enclosed find remittance for your journal. I can't do hard labor any more, but like to read it anyhow.

H. B. TODD, Texas.

**Blacksmith Becomes Owner of Newspaper**—Owing to age and failing eyesight, we have disposed of our shop and have purchased the *Broadwater News* and are wielding the pen now, but not with the satisfaction that we did the hammer.

We have been handing *The American Blacksmith*, to E. A. Stevens, our local blacksmith and the party to whom we sold our business and have been advising him to subscribe for it as it would be a great help to him in his line of business.

WILLIAMS & SON, Nebraska.

**A Progressive New Zealand Shop**—My shop equipment consists of a 3½ Horse Power National Gas Engine, Punch & Shearing Machine, capable of cutting ½ inch plate; Power Bolt-threading Machine, threading screw bolts up to 1½ inch and pipes up to 2 inches; Power Drilling Machine, and also one Hand Drill; Power Emery Grinder and One Foot Grinder; two Forges and all necessary tools and accessories.

I do every class of ornamental gate and fence work, handle all blacksmith work for three auto garages, and have the reputation of being the best motor spring maker in town. I also do shoeing, builders iron work, make all kinds of machine tools for wood planing, lock smithing and lawn mower repairs. I believe firmly in specializing. In fact, if anyone wants a job done around here that no one else can do, any one will say, "Take it to Teddie Toll's."

I want you to send me *The American Blacksmith* right along. I like reading it, it is a good paper and I like your style very much. Sending you £1, let me know when it is all exhausted and if I am still in the trade will send you some more.

Nelson is a nice place with plenty of work for us all, have been going hard now for five years without a slack day, and get top prices for work.

I am sending you a photo of an ornamental gate which I made, and which took myself and a lad fourteen days to make (working 8½ hours a day). The gate is 14 ft. wide and 8 ft. 6 inches to top of the highest point. The large vertical bars are of 1½ inches square iron, and the small



A BEAUTIFUL HAND-WROUGHT ORNAMENTAL GATE MADE BY MR. E. H. TOLL



vertical bars  $\frac{3}{4}$  inches square. The pair of gates weighs 800 pounds.  
E. H. TOLL—New Zealand.

**Welding a Plow Point.** In answer to an inquiry from Louisiana on how to weld plow points, we offer the following. Make the point fit the plow share; then heat plow share and plow point, and when they are a good red take them both out and apply a welding compound between the parts where the lap is. Then with a pair of tongs, squeeze the parts together, and they are ready to make a weld. Start welding from the center out. If you have trouble with parts slipping after you get them on the anvil, you might try this: take a blunt chisel and cut a notch in both pieces close to the back end of the scarf; when you take the pieces out to weld place the two chisel cuts together; this will prevent slipping.

Another good way to weld plow points is to scarf the edges thin; then take a chisel and cut a crease across each lap, so one will fit nicely in the other and cannot slip. Then put welding compound on the top side as far back as the steel is hot, and lay on top of the fire until it is all melted. Have plenty of charred coal under the steel and some on top. Then take a slow heat—not too much blast. Let your heat come up slowly. When it gets to a bright cherry red shut off the blast. Let the steel lay in the fire two or three minutes and then bring out. Hit on the anvil to knock off the dirt. Then place together and strike lightly until the job is well stuck. Then strike hard, and always strike to drive the weld together, but never strike so as to drive weld apart. By doing this you will always get solid welds.

Borax, or some compound of which borax is the main element, makes the best welding compound for steel. There are several ways to prepare it and you might try one of the following:

Melt a quantity of borax in a small crucible. As soon as it has the appearance of a dark syrup run it out on a dry, clean floor to cool. When cool, powder and mix with filings or fine borings or wrought iron or steel; also add a small portion of carbonate of iron.

When using this compound put it on the work when well red—in fact the steel should be just on the verge of a good fuse when it is applied. You will find this flux quite cheap and very effective.

Another very good compound is made up by mixing:

One pound of pulverized borax, with two ounces of carbonate of iron and  $\frac{1}{2}$  ounce nitrate of potash.

One that is said to be especially fine for welding up plow shares or laying plow shares, can be made by adding to every pound of pulverized borax, four ounces of dry venetian red paint (or any colored dry mineral paint). You can burn the edge of the lap and put some of this on it and weld it up making a good, solid edge.

Of course it goes without saying that your fire must be clean and as free from sulphur as possible. Borax always contains a quantity of sulphur, but the process of melting it and boiling it dry described above greatly improves it. If you care to go to a little more expense, which might more than pay for itself, here's a compound which has been used for years by one of the most successful steel workers in the country:

Pulverized borax ..... 1 lb.  
Carbonate of iron ..... 2 oz.  
Black oxide of manganese ..... 3 oz.

Mix thoroughly, and use as you would the simple borax compound, only heat the steel a little hotter.

Concerning the tempering of a cold chisel, the following is recommended:

After the chisel is forged let it cool off, then grind it. When it is ready to harden, heat to an even dark red back as far as it has been drawn. Plunge it into the bath straight down as far as you have it hot enough to harden; move it up and down a little but not sideways. As soon as the chisel is cooled through, take it out and rub one side bright; now hold it over the fire and draw it evenly all over alike to a regular cold chisel blue.  
S. S. New York.

**Now Has Complete Power Equipment—**  
I have been a constant subscriber to The American Blacksmith for the past nine years and I would not know how to get along without it. I wish it came twice a month.

I have been putting power in my shop, and now have the following equipment: a rip and cut off Saw a 9" Jointer, Emery Grinder, and lathe; and soon I am going to put in a Band Saw and Shaper. I have a Meco Gasoline Engine for which I am acting as agent. I do not think there is a better Engine made, regardless of price; it is so simple in construction and no crank is required for starting. I wouldn't be without a power machine in my shop; it don't take long for it to pay for itself.

I do a General line of Horseshoeing, Smithing and all kinds of Wood Work. I will give you a few of our prices of which we are about ready to make a few changes, on account of high cost of material, food, etc. At present we get for common shoes 20 and 40c, for shoes 75c and \$1.00, rubber pads from \$2.50 to \$3.50 depending on the sizes; \$3.50 for a new wagon tongue with old irons put back on; \$3.00 for sled tongue with old irons on; buggy fellows \$1.25 each; wagon fellows 1 $\frac{1}{4}$ " \$9.00; new wagon bolster, front or hind \$3.50; sand ford \$2.50; buggy spokes 20c each, wagon spokes 25c; and so on. As to raising prices, we must do it or quit business, but we have here in this neck of the woods a few smiths, as they are called, who will do work at the same old price anyhow. Now as to those kind, I must say that I am really sorry for them, they surely haven't learned their trade or else they want to do all the work. To these, I would say: they had better go back and work at journey work until they are capable of commanding decent prices for their work.

Now these are just the type of men who are detrimental to the mechanic and do not deserve the honor of being called one. I for one, have yet a lot to learn in the business, and I have been working at the business only twenty years — just long enough to begin to learn some new kinks once in a while. Generally, when a man works at a trade about a year, he thinks he knows about all of it; but the longer he works he finds that he has got another think coming, and sometimes he thinks he don't know but a little about the business. Now brothers, I want to say this: Let every one of us raise prices up to a certain standard and stick to them like a pup to a bone. People expect to pay more, and even wonder how we can do

business at all under the present conditions. It's our own fault if we don't get our price. So don't let the customer set your price; he has all he can do to set his own price.

My best wishes to The American Blacksmith and its Brother Craftsmen.  
WILL W. CUMMINGS, Pa.



## The Automobile Repairman

### Gas Engine Operation Made Simple.—7

The Purchase, Installation, Operation and Troubles of a Gas Engine.

J. L. HOBBS

#### More About Carburetion

Before taking up the carbureter, let us spend a little time with a discussion of the fuel tank and its fittings.

Two systems for carrying the fuel from the tank to the carbureter are used: the gravity system, or some kind of a force feed system. To make use of the gravity system, it is necessary at all times to have the carbureter, in order that the float valve may have a sufficient amount of pressure to operate properly. At the bottom of the tank, the supply pipe (which carries the fuel to the carbureter) is joined. It is well at this point to have a combination screen, trap, drain and cut-off to assist in keeping any sediment or water, which accumulates in the tank, from finding its way to the carbureter. This should of course be cleaned occasionally, or it will be of absolute no service, and in fact, a source of trouble.

The pipe should go to the carbureter by the shortest route, and should be kept as free from vibration as possible or the vibration will cause the joints to spring a leak and will in time break the pipe itself. A small leak will allow a lot of gasoline to get away in a short



time. The bottom of the carbureter should also be provided with a drain so that any foreign substances which might get by your trap in the supply pipe, can be here taken out of the pipe line. Too much care cannot be given the pipe line, and it should be kept perfectly clean at all times.

The carbureter which is the perfected type of the mixer, designed to take care of the variable speeds under which the engine operates, consists of a float, a float valve, fuel bowl, air inlet, needle valve, fuel inlet and a mixing chamber. The latter is sometimes a part of the intake pipe of the engine. Some carbureters are provided with means for receiving warm air from around the exhaust pipe, to assist in vaporizing the fuel in very cold climates. Others are provided with a water jacket through which hot water circulates around the supply pipe and thus warms the fuel before carburetion.

The fuel bowl is just what its name indicates; it is a bowl-shaped container, and generally has an opening through the center for the passage of the air into the mixing chamber. The fuel inlet extends into this opening. In this fuel inlet is a needle valve for the regulation of the amount of liquid fuel going into the mixture.

In the fuel bowl is a float, which is generally made of cork or some other very light substance. The float is hinged to the side of the fuel bowl and is attached to the float valve in such a way as to operate the latter for the purpose of maintaining the liquid at the proper height: about one-eighth of an inch below the top of the needle valve. The float valve is generally made of a very fine grade of phosphor bronze, and must be ground so that it will hold gasoline perfectly. While a little leak might not interfere with the operation of the engine, yet it would allow a lot of your fuel to waste when the engine was stopped.

Before we take up carbureter adjustments, let us show you where a lot of your common troubles will be located. If your float valve is set too low, it will not permit of perfect adjustment of the carbureter. If it is set too high, it will allow the fuel to run over and waste. If it should leak, it will have the same result. If the float becomes soaked with fuel and does not float perfectly, the carbureter cannot possibly operate as it should—sometimes not operating at all.

When the float becomes soaked, "water-logged", as you might say, or for any other reason fails to float, it can be remedied and made as good as new. If it is soaked with fuel, a few hours in the sunshine will have the desired effect. If it is a hollow float, it may have a leak which will let fuel to get inside. This can be remedied by stopping the leak. When the valve leaks, it may be ground with a little fine emery paste, which can be secured at any hardware



WILL CUMMING'S PROGRESSIVE POWER SHOP

store. Full directions for grinding are usually written on the container or wrapper.

Another frequent cause of carbureter trouble can be traced to a small drain purposely left between the carbureter and the intake pipe of the engine. The object of this drain is to allow any fuel which leaks past the float valve to get out of the intake pipe and keep your engine from being flooded in attempting to start it with the intake pipe well filled with fuel. A great many engines have been observed where this little drain has been plugged up with a toothpick or some other means, only to cause the engine to fail to start as explained above. But when this drain was opened and the leak in the float valve remedied the engine worked as good as new.

Another cause of trouble, and a hard one to locate, is a small grain of sand getting into the top of the needle valve, which is just a little too large to go through the opening but which lets some fuel past—enough to give you a sluggish running engine. We will never forget the largest part of the day spent in going a few miles on the road with an automobile which had this ailment. When the little grain of sand was removed the engine ran well and produced all the power that was desired. It is the little things that cause troubles in a carbureter; things that are sometimes too small to be considered as being of any

consequence. Nothing should be too small to attract your attention.

Carbureter adjustment is considered a very difficult matter, one which should only be attempted by an expert. This is erroneous; a carbureter is just as simple as any other part of a gas engine. Of course it is a delicate machine and a small difference in the adjustment will throw it entirely out of the running, but a few simple suggestions will help you out on this difficulty. A new carbureter is generally adjusted so it will produce a mixture that will run your engine perfectly when it leaves the factory, but, if in shipping, or from any other cause it loses this original adjustment, close the needle valve entirely, then open it about three-fourths of a turn. This will generally give you a mixture which will start the engine; after that it is a matter of experimenting to find the proper adjustment. This experimenting should be done systematically, however, and the results watched. You may have to prime the cylinder with a small quantity of gasoline to get the engine started, but when it starts shut off the needle valve until the engine makes a kind of a popping sound back through the carbureter, which is an indication that there is not enough fuel going into the mixture. Open the needle valve until this sound stops and the engine runs smooth, when you have your carbureter adjustment. If there should be a compensating air valve, speed the engine up to about 400 revolutions per minute and open the air valve until the engine begins to miss fire, then close it until it runs smoothly. Keep on with your experimenting until you get the mixture so perfect that the least move of the throttle will make an appreciable difference in the running of the engine.

A carbureter is just a machine, and like any other machine is intended to do a certain kind of work. When it fails to do the work intended for it, there is some little thing wrong. If you will start a systematic search for the trouble, you will generally find it. If a carbureter fails, it will be always for one of two reasons; either allowing too rich, or too lean a mixture. Find out which it is and then work along the line of locating those things which will cause that trouble, and after you have located the trouble you will find it can be very easily remedied.

(To be Continued.)



# TIMELY TALKS WITH OUR SUBSCRIBERS

The American Blacksmith is published monthly at The New Sidway Building, Buffalo, N. Y., U. S. A., by The American Blacksmith Company. Incorporated under New York State Laws. Entered, February 12, 1902, as second-class mail matter at Buffalo, N. Y., Act of Congress, March 3, 1879.

William F. Wendt, President      Albert W. Bayard, Secretary      Walter O. Bernhardt, Editor

Associates: James Cran      Bert Hillyer      A. C. Gough      Dr. Jack Seiter

Subscription Price: \$1.00 per year in advance, prepaid to any postoffice in United States or Mexico. To Canada, \$1.25; other countries, 6 shillings. Reduced rates to clubs of five or more on application. See "Honor Roll" page for money-saving, long-time rates. Cable address, "Blacksmith," Buffalo. Lieber's Code used.

Subscribers should notify us promptly of non-receipt of paper or change of address. In the latter case it is necessary that you give us both the old and the new address.

### Back Numbers

There are back numbers and "back numbers", but the kind that we have special reference to here, are the back numbers of *The American Blacksmith*. There are still some readers who do not seem to realize the value of the back issues of "Our Journal." The Subscribers' Service Bureau is always willing and anxious to help a reader whenever he feels that he needs help, but many of the questions asked are found, upon investigation, to have been answered in some back number of *The American Blacksmith*. We have several times pointed out the value of back numbers, and have also published letters from readers emphasizing the fact—but there are still some of "Our Folks" who do not seem to realize that simply because copies of *The American Blacksmiths* are published on a certain date, or bear the name of a certain month, that the value of that paper will not necessarily end with the end of that month. Many of our readers bind up their copies regularly each year, and quite a number of them have bound volumes containing every number that has been published. When you realize the hundreds of practical items, labor-saving articles, time-saving methods that are published every year, you must realize that a few volumes of this practical journal must necessarily be of inestimable value and help to the practical man.

Consider, therefore, the practical value of the back numbers. Don't think your copies of present value only, keep them for reference and you will find yourself the possessor of a library jammed and crammed full to overflowing of money-saving, profit-increasing smith shop information—information that you can use every day in your daily work.

### Subscription Agents

When a stranger solicits your subscription to *THE AMERICAN BLACKSMITH* or any other publication, insist upon him showing you absolute proof that he is an agent in good standing and is employed by the publication which he represents. Don't under any circumstances, give the man your money if you are not sure that he really works for the paper he says he does. No matter what the man offers you—no matter what price he makes—no matter what premium he promises to send—Don't Give Him Your Money If You Are Not Sure.

### Contents, May 1917

War Has Been Declared!—Frontispiece	184
Levelling the Horse's Feet.....	185
Unique Method of Shoeing Bronchos..	186
The Horseshoer .....	188
Shoeing the Horse for Contracted Feet ..	188
Sand Cracks .....	188
"Horseless Age" Long Way in Future ..	189
Gas Engine Operation Made Simple—8	190
Business Men Who Wait Until "Afterward" for Legal Advice.....	192
A Good Ol' Game .....	193
It Pays to Buy an Advertised Article	193
Smith in the Daily News .....	194
Another Village Smithy—Poem.....	196
Heats, Sparks, Welds .....	196
Our Honor Roll—A new Name in First Place! ..	197
The Machine and Tool Smith .....	198
Fundamentals of Lathe Practice....	198
The Oxy-Acetylene Plant—3.....	199
The Care of Tires—2 .....	201
The Iowa Convention .....	203
Benton's Recipe Book .....	204
The Care of Brushes .....	204
A Cement for Steam or Water Pipes .....	204
Castor Oil for Brakes .....	204
To Solder Aluminum .....	204
To Pull a Rusty Spike from Wood	204
Queries, Answers, Notes .....	204
A Question on Hardening .....	204
Runs a Profitable Farm and Repair Business ..	204
A Business Problem .....	204
Repairing a Cracked Engine Base..	205
To Repair a Broken Pipe Axle.....	205
A Blacksmith Reporter from Georgia ..	205
Answers Mr. Riddle of Utah.....	205
What do we need at Present?.....	206
Another Experience in Price Raising	206
Believes Cash Business Only Way.	206
The Automobile Repairman.....	206
Using "Common Sense" Methods in Curing Auto Troubles.....	206

### Helping Our Subscribers

In the past few months our Subscribers' Service Bureau has been asked more questions than during any similar period of its existence. Subscribers and readers are beginning to lean upon *THE AMERICAN BLACKSMITH* and its very helpful Subscribers' Service more and more each month.

And problems that are placed before us range all the way from questions on the laws and statutes and upon problems of business accounting to all sorts of problems in shoeing and forging work. We are happy to say that few, indeed, are the instances when we cannot give the querist just the help he is seeking. With a staff of contributors who are experts in their various lines, with a trade and technical library that covers practically everything written on blacksmithing, horse-shoeing and allied subjects and with a list of thousands of practical, thoroughly experienced readers to draw upon, the problem must, indeed, be difficult that permits of no solution.

We want everyone of our readers to take advantage of this service and to ask for help whenever they feel the need of it. This service is free to subscribers and is only one of the ways in which *THE AMERICAN BLACKSMITH* fits right into your every day shop needs and requirements.

### THE SHOP NUMBER—Your Number

The coming shop number will be one of the biggest features of the year. But to make it so we must depend on you.

Every subscriber who has devoted any thought and attention to the arrangement and equipment of his shop should write in without delay and tell the Editor all about his shop—what lines he is handling and his success with them, something about the business end of his shop—collections, advertising, cost finding, etc.,—in fact anything about his business that will be of interest and value to blacksmiths in other sections.

You have profited by what brother craftsmen have told you through these columns. Now let them hear from you.

Sit right down now and write what you can. And if you can send in a photo or two, so much the better. Don't hold back on account of your English or inexperience in writing—just send in the facts and leave it up to the Editor to use the pruning shears as he sees fit.



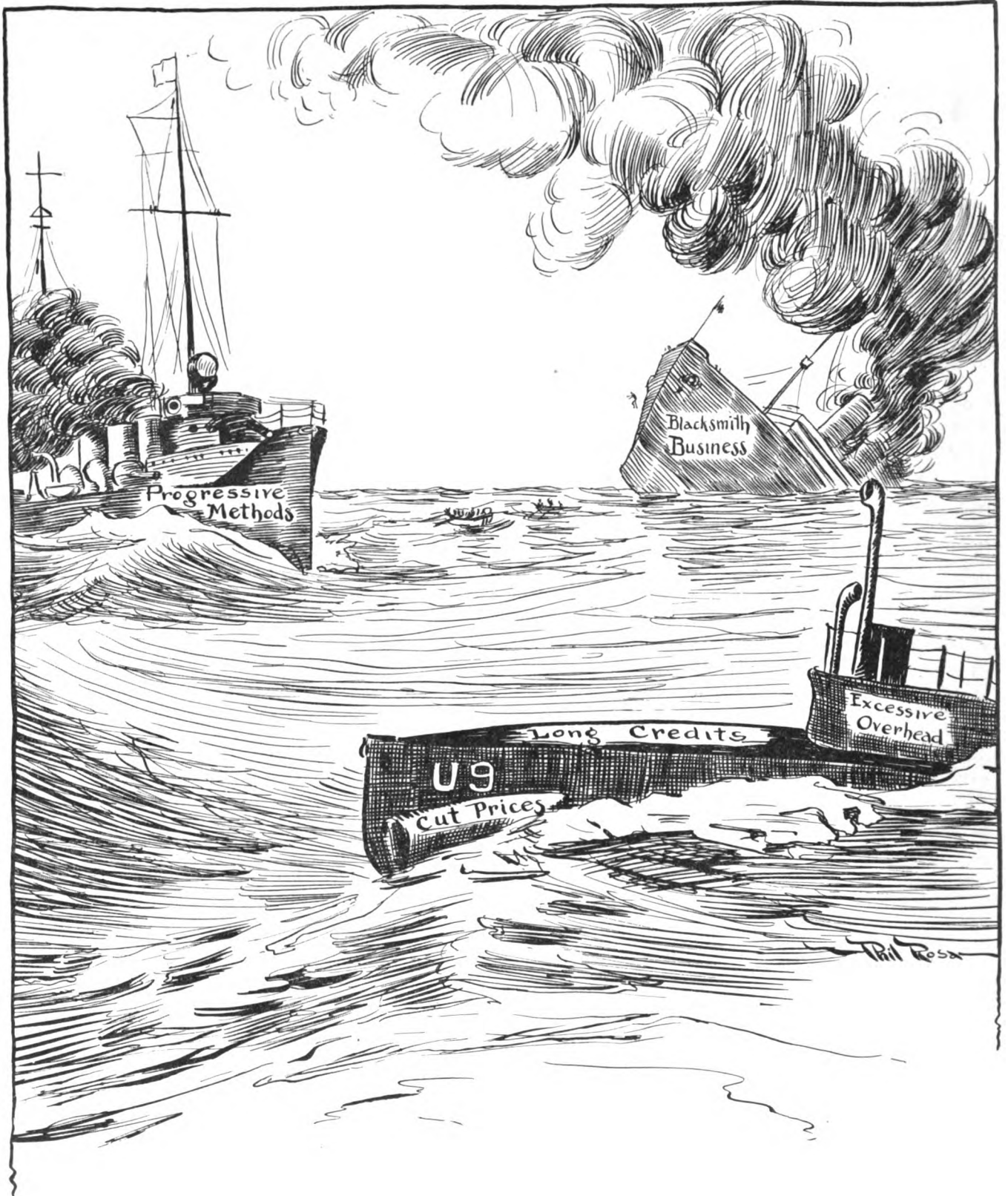

**WAR HAS BEEN DECLARED**

The old-time, destructive methods that have sunk many a business must be done away with. Don't wait until it is too late and your business is no longer afloat—enter the war to-day—war on cut prices, long credits, big overhead, and all the other evils that menace the blacksmith business.



# Levelling the Horse's Feet

A. L. CAMP

BY THE ABOVE TERM is meant the reduction of the ground surface portions of the wall of the hoof in such manner that this bearing surface of the foot will be at right angles with the column of the leg when the leg is perpendicular. Unless the hoof is so adjusted, injurious results are sure and will vary only in their consequences in ratio to the degree of mal-adjustment.

When the hoof's bearing is at right angles with the leg, the latter is enabled to occupy the perpendicular position with the least strain of the ligaments which hold together the bones at the joints. Also, these joints are free to perform their functions of articulation and weight bearing with the minimum strain and friction.

Inside the box of horn which we designate as the foot, lies the pedal or coffin bone. In general shape this bone much resembles the hoof. From its practically immovable position (immovable except for the slight play of the laminae by which it is supported) it must necessarily assume the position maintained by the hoof. That is, if either side or the toe or heel of the hoof be raised or lowered the corresponding part of the coffin bone is raised or lowered as well.

Just below the coronet of the hoof lies the lowest joint of the leg. This joint is formed by the junction of the coffin, the short pastern and the navicular bones—see Fig. 1. This joint is far simpler of construction than that of the knee or hock, but is more complex than the intervening ones. Being composed of three bones, its perfect adjustment must obtain if natural articulation and soundness result.

Ailments most common to the vicinity of this joint are low ring-bones, rupture of the ligaments and the so-called navicular disease.

At the rear top of the coffin bone is a half socket for the accommodation of the lower end of the short pastern. The other half of the socket is upon the upper plane of the navicular. This bone lies directly beneath the rear half of the short pas-

tern. See Fig. 1. The base of the short pastern is of a double knuckle form (Fig. 2) and the socket for its reception is formed to accommodate it. If the hoof is laterally unlevel more of the weight of the animal will be on one knuckle, also a strain will be on the sustaining ligaments of the joint on the side on which the hoof is lowest. This unlevel allows more weight to fall upon one side of the coffin bone and consequently the hoof, than on the other.

If the angle of the foot is natural, equal weight is borne by the coffin and navicular bones. But if the heel is too high (Angle obtuse) the coffin bears more. If the heel is too low (a cut angle) the navicular bears more.

The foot leveller designed by Prof. Russell is a perfect tool for gauging the lateral level of the forefeet. But nothing I have seen will do likewise for the hind ones. Unfortunately only the shoes of horses devoted to racing have the benefit of scientific foot levelling, although such is fully as essential to the welfare of the road driver or drafter. Probably not one shop in one hundred possesses a leveller or angle iron. In his supreme egotism, the general follower of the craft of farriery will tell you his trained eye is infallible. If the builder of houses

should say his eye was so perfectly educated that the use of the square or spirit level was unnecessary, would you believe him? It seems almost unnecessary to say that the first-mentioned tools are as necessary to good work as are the latter.

As probably ninety-nine per cent of hoof preparation is gauged by the eye and the accuracy of the result is unproven by the application of the leveller, there is no evidence, pro or con, of the correctness of the work; that is, the workman does not test, but only guesses that the work is right. There is no doubt but what the carpenter or mason has a better trained eye than the ordinary laborer, but this is because of his constant use of tools of verification. So too has the shoer who uses the leveller, and he certainly will prepare the

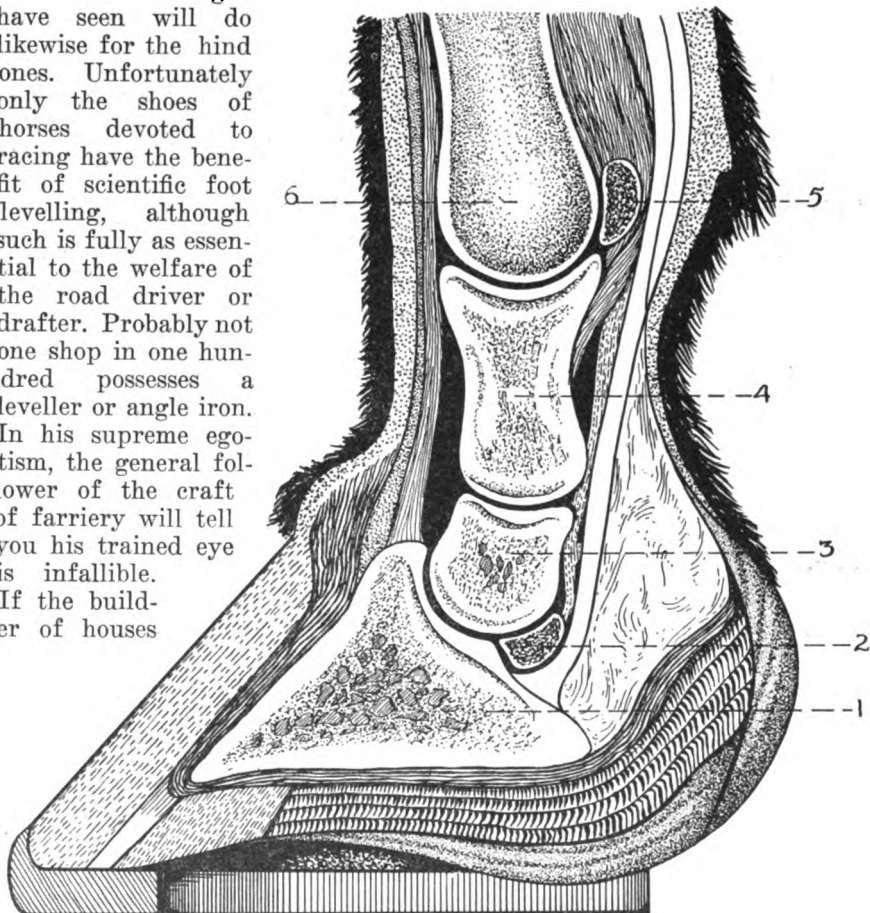

THE CORRECT POSITION OF THE BONES ACCORDING TO MR. CAMP

1. COFFIN BONE  
2. NAVICULAR

3. SHORT PASTERN  
4. LONG PASTERN

5. SESAMOID  
6. CANON BONE



foot nearer right than he who is not in the habit of using one.

I cannot account for it, but to the eye the actually level fore-foot appears high on the inside and the hind one high on the outside. In consequence of this optical illusion, the fore-feet are left too low on the inner, and the hind ones too low on



FIG. 2—BONES OF THE FOOT VIEWED FROM THE REAR

the outer sides. The results of this defective levelling is that the fore-feet assume the toe-wide position in standing, and toe-in when they are uplifted and the pasterns flexed. So shod, the animal will knock the knees or ankles. Then too, from the unequally distributed weight the hoof's shape becomes mal-formed, by the inside heel being pushed up and drawn in; and a "corn" results.

This corn is visible in the angle formed by the wall and bar. It is in reality a blood-stained portion of the sole. This visible part is not the disease itself, but only the evidence of an injury from one to one and a half inches above the stained horn. It is caused by the crushing of the laminae by the contracted wall against the heel of the coffin bone. The inflammation following is accompanied by the secretion of a blood-colored watery fluid which stains the surrounding horn, and eventually through growth of the horn the discoloration reaches the lower surface. Generally two or more months elapse between the period of the injury and the appearance of the corn. A like effect is not uncommon at other parts of the sole which result from bruises of the lamina, but are only designated as corns when in the first named locality.

Bear in mind that the fore-feet will stand toe-wide when the inside parts of the hoof are too low and yet the appearance to the eye is that the reverse is true, regardless of the fact

that when the wall is measured from ground surface to the coronet, the distance will be greater on the inner than the outer wall. This is because of the greater weight having been thrown upon the inner, which is that lower and which has given away and pushed upward seeking relief, while the outer wall has descended from bearing less than its just share. The farrier, who does not understand these conditions and who is misled by the above noted illusion, will cut away the inside to correspond in measurement to the shorter outside in his endeavor to remedy the defect, and only increases the evil.

The foot leveller will tell that the conditions are as described, and if the inside heel is built up, provided the outside has not sufficient wall to reduce to make the lateral level—so that an equal distribution of the weight will follow and the foot so shod, it will in time regain its symmetry and soundness.

With the too-low inside the fore-feet will stand toe-wide. With the too-low outside they stand pigeon-toed or toe-narrow. The level feet stand straight.

Regarding the preparation of the hind feet, I have been unable to find an instrument that gave results comparable with that for the fore ones. But I think it safe to say that the defect in their preparation is in the opposite direction from the fore ones. That is, their outer sides are cut too low. When such is the case the inside wall flares outward near the ground bearing and is concaved from coronet to base, and is under drawn and convexed on the outside wall.

A smith who received his education at a Chicago School of farriery once told me that the inside bearing wall of the forefeet was straighter from heel to toe than that of the outside, and that such was their natural condition. On investigation I found this was not the case with natural unshod feet, for in such the sides were alike in contour and the measurement was equal from the length center of the frog on both sides of the ground surface. Fig. 3. But I did find his statement to be correct when applied to shod feet, and that the cause was from the conditions of preparation discussed above, viz. that almost without exception the fore-feet were cut too low on the inside and thereby unequally distributing the weight and subsequently mal-forming the hoof.

Perhaps some of my readers may feel that in the statement above, I have gone to the extent of unnecessary reiteration; but if such is the case, my excuse is an extreme and earnest desire to impress a full understanding of the importance of this most essential element in the preparation of the foot for the shoe. The nearer the work adheres to the lines advocated in the foregoing, which is based upon the vital characteristics of the foot, the more satisfactory will be the effects following. And that deviation from these principles will most surely produce evil consequences, commensurate to the degree of deviation.

## Unique Method of Shoeing Bronchos

JAMES A. PATTERSON

My first job after leaving school was one as helper in my uncle's blacksmith shop in the village of Newaygo, Mich. (1902) In this shop I worked for a period of eighteen months at ten dollars a month and board. Besides working ten hours a day in the shop, I was expected to do numerous chores around the house, such as washing windows, splitting wood, caring for the cow, and mowing the lawn. This arrangement left me no extra time for amusement, and one day when uncle imposed me another little extra, I gave vent to several things that had been smoldering in my bosom, finally telling him to go to sheol. Despite his protest and promise to relieve me of some of the chores, I packed my valise and started for Chicago, where I found a job as helper in a large shop on Milwaukee avenue, which place I held four months.

While in this shop I learned many things that my uncle did not know, or at least had never shown me; for instance: shoeing horses for faulty travel, a few points about reading habits and character in a horse's eye and the contour of his head, etc. I also came in contact with a man who had once been west of the Mississippi, and who related wonderful tales of the chances for a young man in the west. Listening to his glowing talk I became infused with an impelling desire to visit the El Dorado which I had pictured in my mind. Having \$50 in my pocket I felt that my wages of \$1.25 a day were inadequate for an artisan of such ability as I thought I possessed, and resigned, bought a ticket for Omaha without any definite point



or plan in view; but with a vague, hazy impression that the mining district of Cripple Creek was to be the ultimate goal.

In Omaha I found a job as helper at \$1.50 a day, kept it for six months, when the wanderlust asserted itself. Learned from a patron of the shop that he had a relative contractor in Perry, Okla., who would be willing to pay me \$2.50 a day, promise a year's work—mainly horseshoeing. This man gave me a letter of introduction to his brother-in-law, which I mailed with application for the position. The reply that I received was satisfactory; I forthwith packed up, boarded the train and landed in Perry on schedule.

This contractor, Louis Nixon, usually kept about thirty horses, one-third of them being wild bronchos that had never been shod all'round. These ten horses had been broken to saddle, ridden by cowboys, and when worked were mated with some steady going horse accustomed to the harness; but all were classed as erratic and dangerous for the blacksmith to handle. In fact, three of them had at different times maimed or temporarily disabled two of my predecessors. However, it was desirable to have them shod. One morning Nixon said to me:

"When you have a slack day in the shop I want you to try to put shoes on 'Tony,' 'Blucher,' and 'Aguinaldo'; be on the alert, for they are all bad Indians and liable to send you to the hospital. I'll ask Sam Lomax to help when you are ready for them."

Sam was the stableman, formerly an expert cowboy. At the dinner-table he suggested that I had better not take any chances on shoeing those horses in the regular way; as a parting shot he flung off this: " 'Safety first' leave it to me pard, and we'll get the shoes on or break a tow line in the attempt."

After dinner I took four pieces of cardboard, went into the stable where Blucher was eating, patted and talked to him assuringly as I lifted each one of his four feet, placed the cardboard under, and with pencil marked the outline of each foot, then labeled the cardboards in order to identify them later.

"What time do you want Blucher?" queried Sam as I started for the shop.

"Bring him over in half an hour," I replied. Meantime I got busy on the plates, using the cardboard dia-

grams as a guide. Forty minutes later I saw Blucher emerge from the stable loose, having only halter on with hitching strap tied up snugly beneath his throat, followed by Sam mounted on his favorite horse. Blu-

"Oh, Smithy, bring out your shoes."

Well, as Blucher lay on his right side I fitted and nailed shoes to both left feet, using a small soap box as a stool, Sam letting the feet loose al-

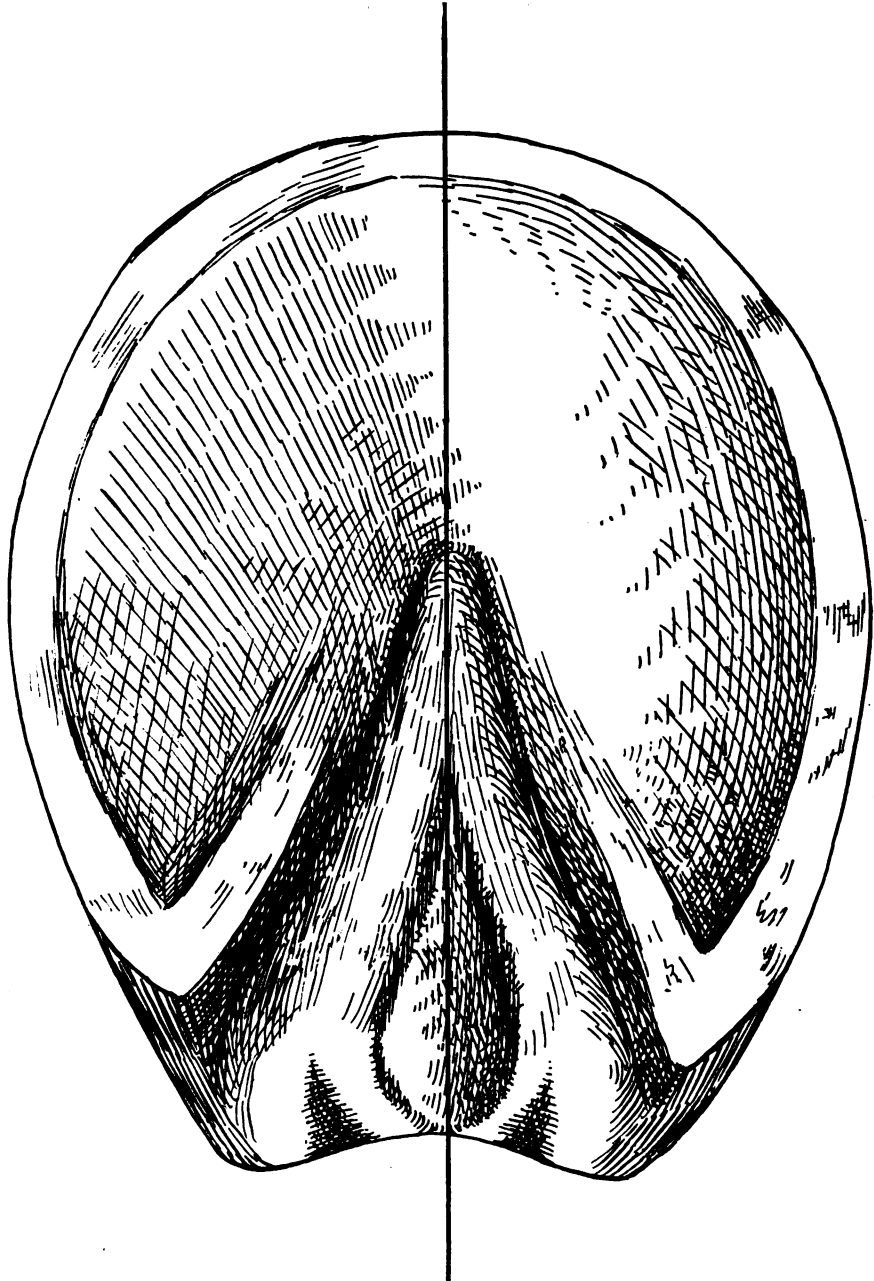

FIG. 3.—THE SIDES OF THE NATURAL UNSHOD FOOT ARE ALIKE IN CONTOUR

cher started on a canter down the road leading to the wagon shed. As he came opposite the shop door, with a dexterous swing Sam lassoed him over the head, another swift curve and the lasso circled around Blucher's fore legs; the horse Sam was riding came to a standstill with the other end of lasso showing two turns around the saddle horn, and Blucher floundering helplessly on the ground. Sam alighted and secured Blucher's hind feet with a bight of the lasso, then yelled:

ternately as I wanted them; also keeping a halter attached to fetlock of hind leg connecting with loop made by halter strap over Blucher's neck as a precaution against a spasmodic kick. Shoes on both left feet, we secured the four feet again, rolled the horse over on his left side and put shoes on both right feet; meanwhile Sam leaned on Blucher's neck smoking his ever-present 'Fatimas.'

Those shoes were not exactly glove-fitting, but they were put on



without mishap. When we released Blucher and he realized what had been done to him he was slightly peeved. He made a dash at Sam as if to bite him; but a quick side-step and a stinging lash from Sam's short whip thwarted his purpose; he then rushed toward me, but anticipating his intention I had stepped into the shop, let down a heavy bar across the doorway. As Blucher thrust his head over the bar I stepped back out of reach, threw an old blanket over his head which momentarily disconcerted him while I escaped through a rear door. Blucher then turned his heels against the shop side, gave two vicious kicks that smashed a board twelve inches wide; then raised each fore-foot alternately and tried to bite off the shoes, and finally trotted off to the stable where Sam followed and mollified him somewhat by giving him a bran mash. Next day Blucher was put to work and behaved fine. When time arrived to reset his shoes we



## The Horseshoer

### Shoeing the Horse for Contracted Feet

T. W. HARLOW

Contracted heels, or contraction in any part of the foot, is perhaps one of the most common and frequent diseases of the horse's hoof, and which may lead to any one of the many maladies to which the foot is liable. Cracks, thrush and corns are, as a rule, the result of contraction in some form; so it is vitally important that contraction of the foot in any degree, no matter how slight, should be arrested as quickly as possible and the foot put into healthy shape and kept so.

While there are numerous causes of contraction, faulty shoeing is pointed out as being the most frequent. It naturally follows that the remedy for this trouble should be sought, if possible, in shoeing; at the same time bearing in mind that the usual methods of softening the horn and preparing the foot should be followed.

A scientifically designed shoe, and one that will prove quite easy for the average horseshoer to make and apply, is described as follows:

After dressing the foot, the part where the bar joins the heel should be carefully cut into—just enough to receive the clips, and thus give a purchase to the shoe so that the foot will be gradually forced back into normal shape. See Figure 3.

A bar-shoe without any calks, and as thin as practicable should be used. A clip is drawn on the inside from the bottom, at both heels, as shown in Figure 1.

Try shoe for width and bend down clips until they appear as in Figure 2 (looking at the shoe horizontally)

Try shoe again, this time making the clips touch the inside of heel, about  $1/16''$  to  $1/8''$  before the shoe does; so that when the shoe is nail-

ed into place it will press the heels away from the frog at all times.

The shoe should be re-set at least every two weeks, and the shoe spread a little at each resetting to renew the pressure.

A word of warning may well be heeded when shoeing for contracted feet; do not expect a rapid recovery, nor attempt to force one. In the case of a foot where the frog has been shrunk and squeezed up into the foot until this normally prominent member has all but disappeared, the frog is likely to be driven still further into the foot if the shoer is too ambitious in effecting a cure. Frog pressure is, of course, necessary, but if applied in too great abundance it will operate against, rather than for a cure. This is a case in particular where the shoer is called on to exercise good judgment.

Other things being equal, this shoe works unusually well, and is especially recommended for contraction occurring in rough, dry country.

### Sand Cracks

A. L. CAMP

A number of times in the last year, I have seen articles upon the cure of Sand Cracks. Most of them offer temporary remedies however and are not based upon the essentials of a permanent cure. So I am offering the following method which has, in my experience, proven an absolute success.

Cracks of the hoof wall are present in nearly every foot. These vary from very small to comparatively large ones. These cracks are really a normal hoof condition—providing that they emanate from the ground surface. They are caused principally from the absorption of moisture and following drying out, such as is due to intermittent subjection to muddy roads or wet stables, etc.

These fissures are of no consequence so far as injury to the foot is concerned, as they are entirely superficial and except for weakening and encouraging the breaking of the lower part of the wall may be dismissed as immaterial.

The Sand Crack is of an entirely different nature and is a most serious matter. Perhaps few disorders of the horse is subject to or is accompanied by more intense pain.

Its origin is at the coronary band, which is ruptured by being pulled apart. The general name is Sand Crack, and may be located at any part of the coronet. If at the rear it is a speciffical heel crack, on the

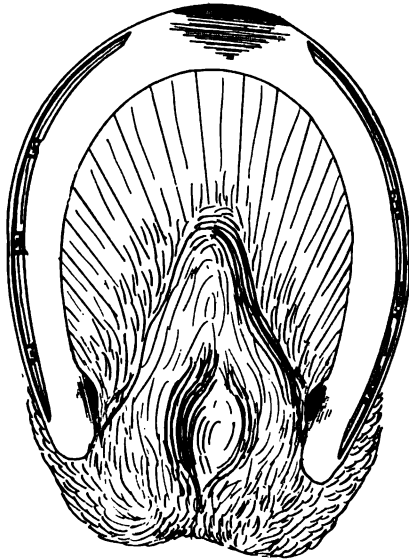

FIG. 1.—A CLIP IS DRAWN ON EACH SIDE OF SHOE

selected an evening after a hard day's work, brought him into the shop, where, with some petting and a delicious bunch of alfalfa to engage his attention, we shod him in the regular way. On the third shoeing Blucher stood through the ordeal as calmly as any of the older horses. The following week we put Tony and Aguinaldo through a similar process with results much the same, although in his struggle Tony gave me a nasty kick on the knee; also when released he galloped off to a nearby woods and was lost for three days.



quarters, a quarter crack, and in front, a toe crack.

The cause is invariably upward pressure. This pressure may be from contraction of part or all of the hoof

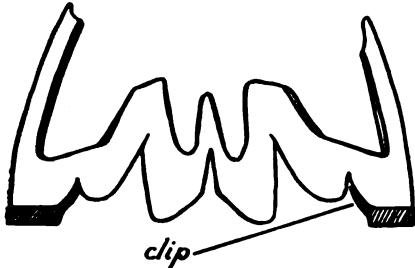

FIG. 2.—BEND DOWN CLIPS

which convexes the sole more than natural and thereby lifts the coffin bone upward; or it may be from the sole or frog pressure, augmented by pads, packing or bar shoes—anything in fact that prevents the proper descent of the contents of the hoof.

Owing to the shape of the wall of the hoof which is a truncated cone with a section removed for the opening at the heel, it is as susceptible to inward pressure as would be any tube whose entrance is larger than the exit. If sufficient pressure be brought to bear in forcing contents into or through it, it will be rent asunder. Such is the cause of Sand Cracks which, from upward force from within, split the hoof at the coronary band, the hoof being less capable of withstanding the pressure on account of its structure than the lower and harder parts. The rupture starts inside of the band and gradually splits its way to the surface and from there downward in increasing rapidity, and in proportion to the pressure exerted.

The Sand Crack is in its nature the exact opposite of the Drop Sole. Where the former effects the narrow and concaved type of feet, which are the subjects of contraction, the latter effects the flat type whose tendency is a too great expansion. Such being the case, the treatment of one logically is the opposite of the other. The Drop Sole must be supported to prevent an increasing downward pressure and the Sand-Cracked victim must be encouraged toward the Drop Sole condition by permitting the expansion of the lower or ground surface of the wall which will in turn allow the flattening of the too greatly arched sole—which tends to lower the coffin bone and relieves the pressure from the coronet.

To do this enough of the frog should be removed so that it will re-

ceive none of the weight. The sole should be thinned sufficiently of its dead surface so that it will more readily respond beneath the coffin. A shoe of moderately thick material should be employed and if possible, of web as narrow as the wall itself, so that no pressure may be thrown upon any part of the sole, but leaves it perfectly free to descend. This method will automatically close the crack at the coronet. If the crack does not extend from coronet to bottom, the injury will heal of itself, and without further help; but if from long standing, it does extend entirely to the bottom, the holes in the shoe should be so punched that a nail may be driven on each side of the crack. But for best results it should be remembered that the foot should be dressed level, that an equal bearing of the weight be borne by all parts of the foot.

### A "Horseless Age" Long Way in Future

Some prophets and sons of prophets who predict that horses on the farms and in the city streets will soon be but a memory, will have passed away, and pleasing epitaphs will be carved into the stones which mark their resting places, long before their prophecies become fact.

The position occupied by the horse, as compared with the motor vehicle—the pleasure car, the auto truck and the tractor, has become a subject of much speculation and contention of late years. There seems to be a never-ending fund of arguments for both sides of the question and we have frequently added our own quota.

The horseless farm—or city, is a long way off—if one is to judge at all by facts. Government statistics point out that there has been a great increase in the number of horses

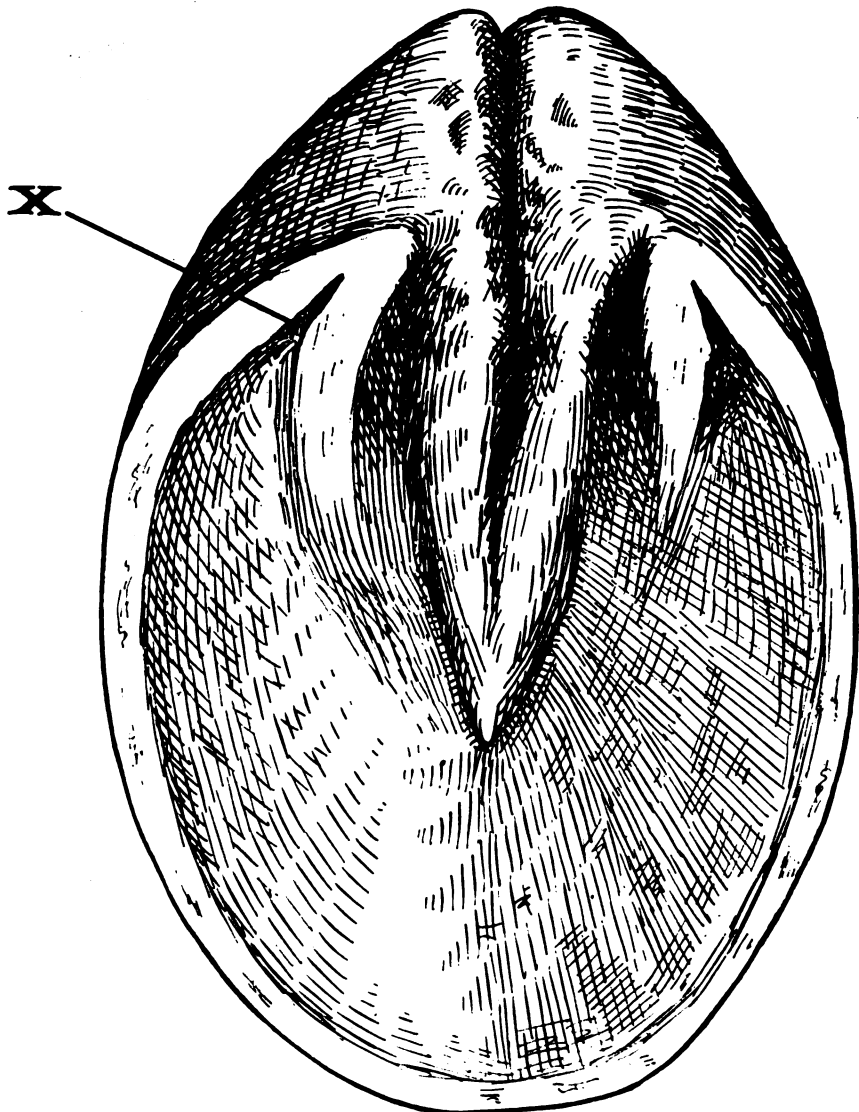

FIG. 3.—WHERE THE CLIPS JOIN THE HEEL, CUT IN SLIGHTLY—X



during recent years, and we see on all sides new evidence of the horse not only holding his own but rapidly coming back into places of favor where he was temporarily abandoned for the more popular automobile. This is especially noticeable in the case of the stylish rider and driver among the fashionable sets in our larger cities. The ultra-fashionable world is forever seeking exclusiveness—something distinctly different and unattainable by the majority. It would seem that the very popularity of the automobile is now bringing the noble horse again into his own—an animal of refinement and not merely a beast of burden.

The automobile has come to stay. This is an indisputable fact. But there is still a place for the old friend of man—his horse, and there will be for many generations to come. This should be a consolation to the older members of the craft whose lives have been spent in skilled and faithful service, and a source of stimulus to the younger blood, that they too may achieve the skill of their fathers and learn to treat the horse with the same care—never forgetting that the Golden Rule applies

equally to man and horse. The advent of the motor car is bringing new opportunities to the blacksmith. But it should never cause him to fully forsake his craft in favor of the "gasoline steed." There will be a place for the shoer for many years hence—and he is the only one with the skill, the craft knowledge and the knack to care for the horse as he should be, and to see that he is shod in a manner worthy of this much-loved animal.

### Gas Engine Operation Made Simple.—8

The Purchase, Installation, Operation and Troubles of a Gas Engine.

J. L. HOBBS

#### Ignition

This important and very much misunderstood part of a gas engine can be made as simple as any other part of it. The main thing which makes ignition hard to understand is the fact that electricity is not generally understood.

If you have any doubt as to electricity being a real live and existing force that can easily be dispelled by taking hold of a wire, which is at-

tached to a set of dry cells and a good coil, with one or both feet touching damp ground.

There are two general systems used for ignition purposes: the jump spark system and the make and break system. Both are properly named, as both do just exactly what their name implies.

The make and break system produces a spark by making a circuit and then breaking it. The parts necessary for a make and break system are the current, which may come from either magneto or battery, the necessary wiring, a movable electrode and a stationary electrode and the necessary means for operating the movable electrode.

The movable electrode is nothing more than a piece of iron or other suitable metal placed in the igniter frame, in such a way that it can be rotated through an arc of a circle. On the end which goes inside the cylinder, is an arm extending about an inch from the diameter of the movable electrode. On the end of this short arm is a small point which is set in such a position as to match with and touch a similar point in the stationary electrode. These points

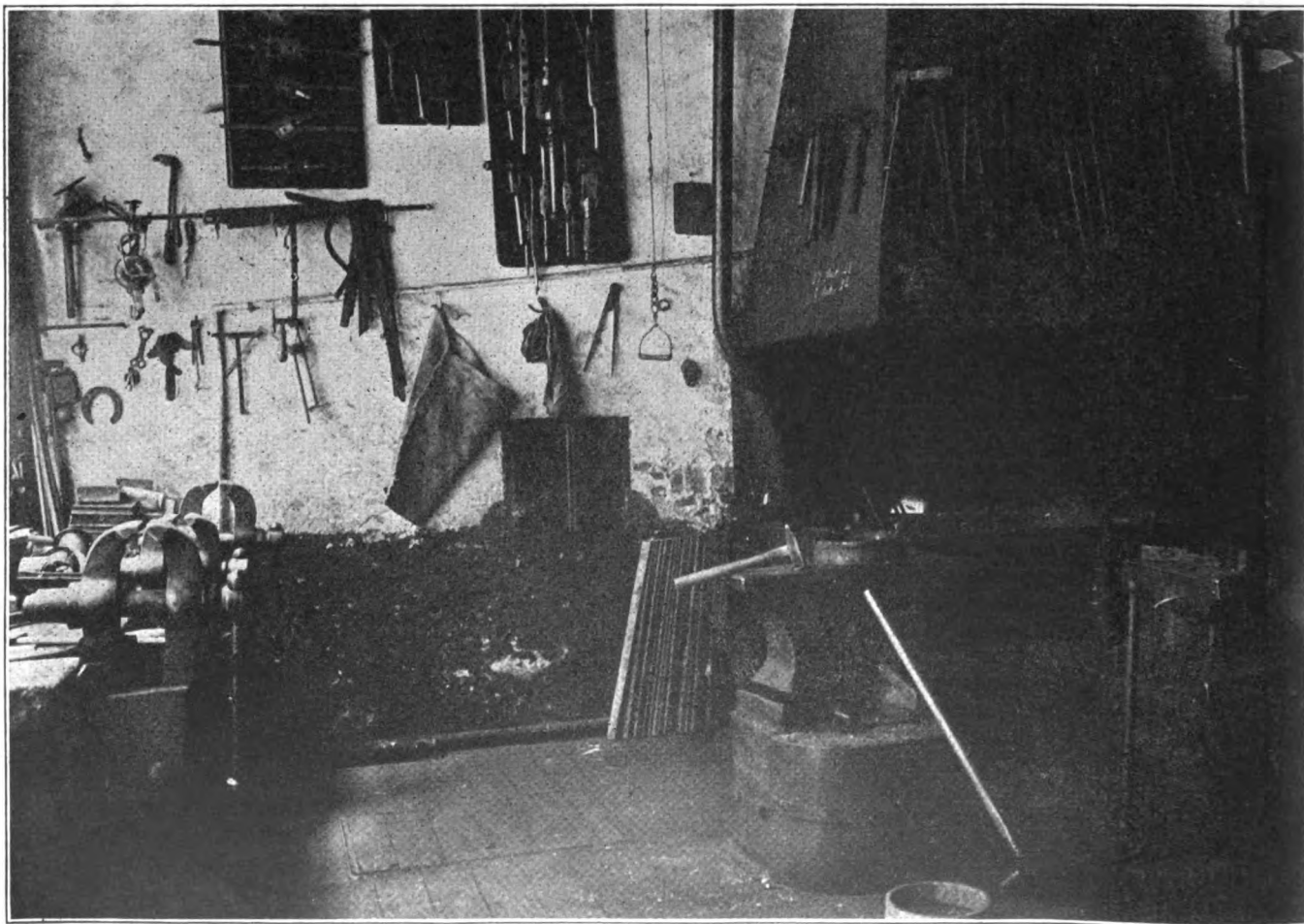

THE CORNER OF A WELL-LIGHTED, NEATLY-ARRANGED SMITH SHOP



are made of platinum-iridium generally, on account of its splendid heat resisting qualities, but other substances can be used. The best and cheapest substitute for these metals is the nickel of a five cent piece.

On the outside end of the movable electrode is what is called the igniter finger. This is a small piece of metal extending from one to two inches upward from the movable electrode, or at right angles to it. The office of this little finger is to trip the igniter at the proper time to make the spark. The outside end of this igniter finger and also the end of the push rod which comes in contact with it are generally case-hardened to prevent excessive wear.

At this point it would be well to mention some of the troubles of the movable electrode. This must fit the igniter frame very close and yet turn freely. If it fits loosely it will allow some of the compressed gases or the exploded charge to escape, which will of course cause a loss of power. If it does not turn freely it might prevent the spark or delay it until it would impede the power of the engine.

An example will illustrate what we mean. A tractor was being used for plowing, etc. The owner tried to start it one morning without results. He removed the igniter and tested it on the outside of the cylinder with the frame touching the metal part of the engine and obtained as good a spark as one would want, but when replaced in the cylinder the engine still failed to move. An expert was called, who took with him a new igniter. As the old igniter was already out the new one was placed in the cylinder and the engine ran as nicely as could be expected. The old one was again tried, but failed. Then it was plain that the trouble was in the igniter. It was again placed in the cylinder and the intake valve removed so that the spark could be tested in the actual running position. The spark was evidently there. The thought then came to the expert that possibly the compression of the engine was having some effect on the igniter. A finger was placed on the end of the movable electrode to imitate the compression in the cylinder. The igniter stuck, which showed him that there was his trouble. He removed the igniter and removed the movable electrode and found that it had been corroded by the intense heat to which it had been exposed in the cylinder. When this was all reme-

died the igniter was put back into the cylinder and the engine worked first class.

Another instance which will help to show the importance of the igniter and the necessity of having it in good condition, follows: A large tractor was being used for filling silos, plowing etc. The owner reported to the general agent of the company manufacturing this particular tractor, that his magneto would not run the engine. An expert was sent out to investigate. He found a very dirty magneto which he washed and cleaned throughly, but this did not remedy the trouble. He then took the magneto off and tested it for magnetism and also for resistance by turning it over by hand, to see if it turned harder at one point than at another. He found that the resistance was there as it should be, that is: that at a certain point where the current is produced in the rotation of the armature, there was a tendency for the armature to turn the other way. This indicated that it was right. There being another engine of the same type in the community, this magneto was placed on the other engine and tried, and worked satisfactory. It was then sure that the trouble was not in the magneto but somewhere else, so he began his investigations by removing the igniter, which was covered with a coating of carbon. It was decided to make this igniter look like a new one and see what effect that would have on the magneto. When this was done it was replaced and the engine started on the batteries and switched over onto the magneto, which took up its work and did it nicely. Now you are wondering what this incident has to do with igniters. It has everything to do with this particular igniter, for the trouble was in the igniter and not in the magneto. We want to make this very clear as it will help you many a time when otherwise you might fail. The carbon on the igniter is a conductor of electricity. If the two points on the electrode has been perfectly connected, the engine would not have run on the batteries, but it not being of sufficient thickness allowed the weaker current from the batteries to pass through the electrodes in the usual way, but the minute the heavy current from the magneto came it immediately took the partial short circuit formed by the carbon and did not go through the electrodes so that there could be no ignition. Now the

point we want you to learn from this, is to see that the igniter is in perfect condition; for it is very essential that it be so to get the best results from your engine.

Let us now turn our attention to the jump spark system of ignition. The wiring is the same for both systems, so we will take that up later and go into it thoroughly after having explained both methods of ignition.

The jump spark system is also very appropriately named, as the spark is made by causing the current to jump a short gap inside of the cylinder at the time the ignition is desired.

This system consists of, beside the wiring, batteries, coil, etc., common to both systems, a spark plug and a timing device of some kind. The spark plug consists of a shell through the center of which is placed a piece of platinum wire, insulated from the outer shell by means of either porcelain or mica. On top of spark plug is attached a screw and nut for the purpose of attaching the wiring in a rigid manner. At the inside end of the spark plug shell is also a small piece of platinum wire extending in the direction of the center wire, but which does not quite touch it. The space between the ends of these wires should be the thickness of a dime.

With this system of ignition it is necessary to use a vibrating coil. The office of this vibrating coil being to intensify the spark and also to cause a number of sparks to pass the gap in rapid succession. It is so rapid that the impression to the eye is that of a continuous fire; yet it is really a succession of sparks.

When the two points of the timer come in contact the current passes over the wiring through the center wire of the spark plug and jumps the gap to the other wire which takes it to the frame of the spark plug, and thence to the frame of the engine where it is again returned to the batteries or magneto.

There are a number of things which could cause trouble here, so we will stop a minute and consider some of the most important ones. A broken insulation on the spark plug—say a cracked porcelain or grease-soaked, mica washers are common source of trouble. Here the current gets across to the frame of the spark plug without going to the points as it was intended to do; which of course, causes the ignition to fail. Sometimes these cracks are





so small that they can not be seen by the naked eye. You can take the porcelain out of the spark plug and by passing it over the metal part of the plug and watching for a spark you can always detect it by the spark which will always show when an electric current is compelled to jump a gap. This kind of a porcelain is worthless and must be replaced either by a new porcelain or a new plug. Some times the new plug is the cheaper way of the two.

An incident comes to mind, where and expert was sent a day's journey, to see why a 2 cylinder-opposed engine was furnished with a magneto which was so arranged that it would throw a spark into both cylinders at each revolution of the fly wheel, (it was only necessary to alternate the spark each revolution). The plugs were believed to be the cause of the trouble. One was tested and it proved to be all right. The other was tested, but the spark failed to appear. The porcelain was removed and tested as above, and although no crack was visible to the naked eye, the spark came through and was visible. A new plug was inserted and the engine ran as usual. You are now asking the question why the engine would not run on one cylinder if the one plug was good. The answer is simple. Electricity always takes the route of least resistance, commonly called the shortest circuit. The broken porcelain being the shortest circuit all the current went this way leaving nothing to go through the good plug, because that gap in the plug was too much resistance for it.

Care should be taken that the plug fits into the cylinder so tight that there can be no leak, and also the plug itself must be put together with air tight gaskets to prevent an interior plug leak. A small leak around a spark plug will let a lot of power get away and may also allow enough air to get into the mixture to interfere with the proper working of the ignition system, by making the mixture too weak to fire. This will be explained thoroughly in the chapter on Compression.

### Business Men Who Wait Until "Afterward" for Legal Advice

In this I want to depart a little from the usual scope of these articles, and say something which

I think needs to be said, in view of what is constantly transpiring in my own experience and in that of every other attorney in active practice.

Sometime ago I asked a man why he had not done a certain thing which he should have done in order to protect his rights. He had failed to do it, and consequently made a loss. "Because," said he, I'm afraid of the lawyers. I knew that if I did that I should have to have a lawyer, and I felt I'd rather go it alone." But in the end, after he had made one loss and was facing another even larger, he had to go to a lawyer after all.

The thing that I want to say is that every business man will save money in the long run if he will go to a lawyer *before* and not after something happens which may involve a legal liability. Any lawyer will charge less to give an opinion as to the thing to do *before* something happens, than he will to extricate you from a mess afterwards.

I want to say also that there is absolutely no reason why any business man should be afraid to go to a lawyer. He is always protected. He can ask the amount of the fee in advance, or if he has not asked what it was to be, and a bill is rendered which he considers excessive, he can always refuse to pay it, and the lawyer will have to go into court and prove that he earned it, just like any other plaintiff. The case will be decided, moreover, by a jury of laymen.

Almost every day something comes under my observations which shows what a really disastrous thing it may be to go through certain business transactions without legal advice. Let me set a few of these cases down; they have all come up in some way in my own practice within the last few weeks.

A manufacturer who is a master of his own line, but who of course knows no law, bought a piece of real estate not long ago on very advantageous terms. A chance came to sell it, after holding it for about eighteen months, for about twice what it cost him. He thought he knew how to draw an agreement of sale, so he went to a stationer's and bought a printed form. This he filled out, as he thought it ought to be, signed it and gave it to the buyer.

Upon this real estate there was a railroad right of way, and also a right of access by neighboring owners. Under the laws these are in-

cumbrances. The printed form which the manufacturer signed bound him to convey "free of all incumbrances." He did not take in the meaning of this at all. When the time came to settle, the buyer declined to take title because the seller could not convey "free of all incumbrances." This most advantageous sale, therefore, fell through.

A lawyer, if he knew his business, would have learned what incumbrances were in the property and whether they were removable. If not, he would have eliminated the words from the agreement of sale. Failure to consult a lawyer in this case literally cost this man about \$25,000.

A wholesale dry goods merchant whom I used to know well, fell out with his two sons. His health began to suffer and he decided to make a will. Like many another man, he thought he could draw it himself, and this he did, leaving all of his considerable estate to his brother's family. The will was badly drawn, and when the sons, after his death, attacked it, it fell to pieces, and the two sons got the whole of his estate. Failure to consult a lawyer here probably caused the old man to turn in his grave, if he knew what was going on.

An acquaintance of mine became interested in a scheme to exploit a certain mechanical device which promised to be a decided advance over everything else of the kind. He decided to put \$5,000 in it. Desiring to economize in lawyers' fees, he merely consulted a patent attorney in order to see that the patents had been regularly issued, and would likely hold water. Upon receiving a favorable report as to this, he put in his \$5,000, only to find, in a little while, that the device was not developed as a commercial proposition anywhere near as far as he thought it was, and that his \$5,000, instead of going toward the expense of marketing, had to go toward developing. It turned out that the \$5,000 was nowhere near enough, and when it was gone, the developing was still incomplete. No other money having been secured, the enterprise died a natural death.

A good lawyer is usually a good business man. Had one been consulted in the case he would have advised the employment of a mechanical engineer to learn how much more development work was needed. A simple thing to think of,



it seems, yet it did not occur to the investor.

A grocer sold out his business and went into the saloon business. He rented a valuable property and got his license. The lease was of course in writing, but *he says* there was a verbal understanding that the lease should last only as long as the license; in other words, that when the saloon closed up there for any reason, the lease should end.

After having been in it for a little over a year, and when the second year was about a month old, the saloonkeeper decided to have the license transferred to another property. This he did, and refused to pay any more rent for the old building, on the strength of the above mentioned verbal understanding. The owner sued him and got judgment for eleven months' rent. The court said the verbal understanding wasn't any good—it should have been in the lease.

No lawyer was employed in this transaction. A good one would have insisted that the proviso about the lease and the license ending together, be put in the written lease. He might have charged \$25 for his services, whereas the cost of not employing him amounted to over \$500.

I could go on writing about these cases almost indefinitely, simply by drawing on my memory. Some of the lawyer's most profitable clients are the men who preferred to wait until "afterward" for their legal advice.

(*Copyright, 1917, by Elton J. Buckley.*)

### A Good Ol' Game

When grandad was a youngster,  
An' baseball warn't known;  
Folks used t' play a fine ol' game,  
—But those days now are flown.

'Twas called jes' pitchin' horseshoes  
An' played by young an' old—  
The parson an' the grocer,  
On days both warm and cold.

A-tossin' back an' forth—you  
Should see the fun they had.  
There ain't a game that's played  
today,  
Can beat it. No, by dad!

—  
What has become of this fine old game? At least in our larger cities? There is one city that still has a love for it. Perhaps some of the

city fathers just had a longing brought back by thoughts of their own boyhood days. Be what it may, one of the largest cities of the middle west has provided for pitching horseshoes in its public parks, and the enthusiastic endorsement of the city council, and the reception of the game by old and young alike, seems to promise its return for all time.

The St. Louis plan to provide for pitching horseshoes in the public parks has our enthusiastic indorsement. We have looked with pleasure and approval upon the development of their Park Department's policy in the encouragement of athletic exercises, a pleasure which at times has been somewhat lessened by the thought that so many splendid games require equipment that a large number of people cannot afford to buy. But no such objection applies to the game of horseshoes. It requires no special costume. On the contrary, it rejects the idea of costume with deserved contempt. Any sort of old clothes is appropriate, the older the better. And for the game itself, all that one needs is a number of well-worn horseshoes of satisfactory heft and feel, which may be begged, borrowed or purloined from a blacksmith shop, or picked up in the street, if one's luck is good. The shoes that are best adapted to the game cannot be bought. New shoes are an abomination, a gross violation of the ethics of the game, and wholly unsatisfactory in action. Besides they make the fingers sore.

But given the right shoes and the pegs properly placed there is no finer game than horseshoes. It is excellent exercise, not at all violent, and it may be played at any age or by either sex. Note the "may" in that statement. Horseshoes is a game of skill. Any one *may* play it, but few *can*. It requires a good eye, an intuitive sense of distance and the knack of giving the shoe a spin that holds it flat upon the ground when it strikes, instead of landing on its edge and rolling into the outer spaces that are unworthy of measurement. No game exceeds it in the joy of contest. Not even a forty-foot put will produce the exhilaration of a "ringer," and as for two ringers, the feeling cannot be expressed in any language with which we are familiar.

We have heard "pitchin' horseshoes" referred to as quoits. Maybe there is such a word in the approved dictionaries. But as for us "there ain't no such game!"

### It Pays to Buy an Advertised Article

In one of the liveliest towns of the middle west is a small, but progressive factory devoted to the manufacture of high grade gas engines. Its product is fairly well known and is classed among the best of its type.

But the manufacturer has never advertised to any extent and the output of his plant is small—less than two thousand engines a year.

In another state is a big, firmly established institution making a similar type of engine. The owner believes in advertising and spends a large share of his profits yearly for advertising. His name is well known in every state in the union, and there's hardly a smith in the craft who would not recognize it—even those in the most out of the way locality.

During a conversation with an agent of the first mentioned manufacturer, he explained, in answer to our query, why their engine could not be sold as cheaply as that of the other—which was so well advertised.

"Of course, the "—" Gas Engine is not as good as ours", he said "but it is the biggest dollar-value for the smith on the market today. His low price is not so strange when you consider everything.

"Take us, for instance. We make an average of 1900 engines or less a year. We maintain agencies in the principal cities, and our agents are well paid men. Their salaries, together with our factory overhead, labor and material costs, and dividends, must all be paid out of the sales of these.

"On the other hand, the '—' Plant manufactures half as many engines in a single day as we do in a whole year. And while their factory is large enough to house us in a single department, their overhead expense is comparatively low. And dividends! Whew!—if we made as much in two years, as they make in a month, we would all have our own private yachts.

How do they do it? Well, they buy their materials in larger quantities and get the best prices possible. Instead of one man working on several parts, as in our place, each man working in "—"s" Plant has his own special job—the place is so organized that an employee specializes wholly on the making of a single part, thus be-



coming more efficient all the time. They maintain a staff of inventors, and experts who make it a business to work out improvements and to constantly find new and better ways to improve the engine and lower its cost of manufacture. They can actually cut down their profit on each engine to a point at which we could not exist, and yet make good money. And there's such a demand for their product that the plant is taxed to capacity all the year 'round, and even now they are considering building a big addition to the present plant."

We could not help but compare the two plants. While there was no question in our minds as to which was the better engine originally, we began to feel that the one which sold at the lesser price was already far in advance of the more expensive make; and the manufacturers of the later were simply resting upon their former reputation to keep up sales.

We have observed that the same state of affairs exists in many other lines, and we have come to this conclusion: that the manufacturer who advertises, is actually in a position to offer a better article at a lower price than the one who does not.

But you will say, "Advertising costs money. Who pays for it?"

And naturally, believe that the one who buys pays the bill.

But here is a seeming paradox; although the advertiser must reckon his advertising cost in calculating his profits, as a matter of fact, the buyer does not pay for it at all.

For advertising lowers the cost of the product, as we have illustrated above; and in the end he gets his purchase at much less than he could, were the goods not advertised.

Which all goes to prove that "it pays to advertise", and *it pays to buy only advertised articles.*

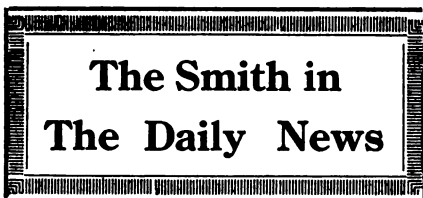

#### Another Smith Shop Tragedy

Many is the strange tale that comes to us from the four corners of the earth, and among those that reached our desk this month, the following is unique:

William Marlett was shoeing a fine horse in his commodious smithy at Hanover, N. J.

The animal diverted itself, as horses sometimes do, by chewing along the wall in front of it, finally reaching a line of

wires. It seemed to relish the tar insulation in particular until it had chewed through the insulation and exposed the live wire beneath. The shock ran down through its hind leg to Marlett.

Although it is said that electricity travels some 188,000 miles a second, we are of the opinion that—at least Bill thinks so, that the current was not a bit faster than that horse's hoof, which instantly shot out carrying the hapless smith with it. Bill's sympathetic uncle tells us that he went clean through the side of the smithy. But we think he was talking through his hat.

#### Navy Urges Enlistment of Blacksmiths

Daniel Brock of Orange, N. H., for many years a successful blacksmith of this place, has sold his shop and enlisted at Portsmouth for work in the Navy Yard.

A new Bulletin urges the enlistment of several hundred men as machinists, tool-makers, machine operators, and blacksmiths for service on shipboard and in the various arsenals and navy yards. The pay ranges from \$1.36 to \$5.00 a day. Applicants should address Civil Service Dept., Washington, or local recruiting depots.

#### Cosmopolitan Shop Proves Its Loyalty

We hear that keen rivalry exists between the smith shops of Indianapolis, each trying to outdo the other in some little patriotic act or duty to their country in this time of national peril and danger of internal dissension.

In the big Pennsylvania shop the employees, who comprise Germans, Hungarians, Canadians, Irish, Poles and native born Americans, all joined in a popular subscription for the purchase of an American flag to float over their shop.

The example of these shopmen of various nationalities and with antagonistic sympathies in the great European war, uniting under the bond of allegiance to the American flag, is indeed an inspiring spectacle. Such a devotion to citizenship at this particular time is such as to give the lie to the insinuating charges that are brought against certain hyphenates in this country. The international crisis which the United States is now facing has proved its efficacy in bringing all nationalities into the one fold of Americanism.

#### Another Kink on Welding Wide Stock—

In your journal for January, 1917, we read an article by L. J. Thomas, Ohio, desiring to know how to weld 15" wide stock in an ordinary blacksmith fire and we volunteer to give the following information:

Before your stock is circled into a ring, scarf both ends as shown by the engraving by cutting a piece out of each side leaving centre longer, allowing for the two ends after being turned around ready to weld. Weld the centre first and then lay a separate piece in on each side with a separate heat, commonly called a "Dutchman."

We think the accompany engraving will show clearly just how this work is done. W. M. PEASTON, Connecticut.

Sugar, flour and print paper are not the only things that come high these days. But the blacksmith, as well as the grocer, and the publisher is paying a decidedly advanced price for almost all his materials. In consequence of this, the horse-shoers of Independence, Missouri, will raise their prices on horseshoeing. It is probable that the prices of general blacksmith work will also have to be advanced.

#### Veteran Blacksmith Retires From Craft

Max Hammerle of Loydsville, Ohio, can boast of an interesting and useful career in his chosen vocation, having served the public for a period extending over fifty years.

He first learned to swing the hammer over an anvil back in 1861 in Decatur County, Indiana. He went from there to St. Louis, where he worked in shops for a time, thence by boat to Wheeling, West Virginia, where he remained until 1867 when he removed to his present site in Loydsville. He has followed the good old Jewish injunction to "give your boy an honest trade" and brought up his son accordingly to follow in his footsteps as a worthy son of Vulcan.

#### Tragic Murder in Smith Shop

One of the most sensational murders of recent years was committed in a blacksmith shop of Walden, N. Y. The cause was attributed to failure on the part of a well-known blackhand leader of New York City to get a Mrs. Delio to leave her husband and join the gang.

After repeated attempts and large money offers to induce the woman to accompany him, Rimalei, the gang leader broke into her house with intent to force her to go with him. She fled to the street with Rimalei close in pursuit. A convenient blacksmith shop offered a possible refuge for her and she entered its wide open doors. The brawny blacksmith tried to interfere, but found himself looking into the muzzle of a long, black revolver. Rimalei fired two shots at the woman, which killed her instantly, and ran, waving the smoking pistol down the street. He jumped into a Ford car and ordered the driver to put on all speed. The driver did so, but drove close by the house of the Chief of Police, and the latter was soon in pursuit of the speeding fugitive. A lively duel between the two cars followed, and finally Rimalei was wounded, and another shot from the chief finished his career.

#### Converted in His Own Shop

We have often stated that there are just as many blacksmiths who can quote Scripture as grocers and other tradesmen, but here's a new one:

Mr. I. L. Barnett of South Zanesville, Ohio, recently extended an invitation to all those present at the cottage meetings, which were being held at the time as part of a revival, to conduct a meeting in his shop. He arranged his usually grimy place of business into a very presentable "church" with accommodations for about forty visitors. Thirty-eight actually attended and were comfortably seated. The owner was carried away by their enthusiasm to such an extent that he too was converted, and stated that he would soon affiliate with a church.

We are of the opinion that, aside from whatever religious benefits resulted from this prayer meeting, it was the best piece of smith-shop advertising that's been pulled off in a long time, although we do not think Mr. Barnett had such an idea in mind.

#### Blacksmith Came for Drygoods—Tanked Wet Goods Instead

Joe Dillon, a blacksmith, was arrested for drunkenness not long ago. He bashfully admitted in court that his age is 56. He said he came over to town to buy some clothes. Instead of sampling dry goods he



started in on wet goods. It is hardly necessary to finish this scene, but suffice it to say the next scene showed Dillion on the way to the court house on the floor of one of the police auto-buses, "soused" to the gills. Unable to pay a fine of \$5.50 the blacksmith went back to jail for 10 days where he became a much more sober, sadder and wiser man.

#### Blacksmith Victim of Hold-up

August Walta, a well-known blacksmith of Valley Village, N. Y., met with an adventure that not only deprived him of a large sum of money, but nearly cost him his life.

As he approached the bridge which spans the Mohawk River at Fonda, N. Y., he was approached by two young women who asked him to escort them across the dark bridge, it being quite late at night. He obligingly acquiesced, and the trio started across. Near the center of the bridge they met two figures who ordered him to throw up his hands. This he did while one of the men rifled his pockets, removing a wallet containing \$150.00. All this time Walta was closely eyeing the other man, who was covering him with a revolver. Seeing his chance, he suddenly knocked the gun from his hand and grappled with him. The women screamed and fled, while the other robber joined in the tussle. They managed to get the best of him, when one of the men stunned him by striking his head with the butt of the gun. They then attempted to drag Walta to the rail of the bridge and lift him over, but he quickly revived and made it so hot for them that both men turned and ran rather than continue the struggle and run the risk of being caught by the authorities.

Walta tried to follow them, and managed to see them enter a hotel. But he could not locate them after that and finally gave up the search, notifying the sheriff of the case, and urging an immediate search and investigation.

#### Shop is Demolished by Snow Slides

At this time of the year one would hardly expect to hear of snow, much less of it doing any damage. But we have just learned of a rather peculiar accident happening up in the mountains of Idaho.

The snow slides, which usually come piling down the sides of mountains and canyons long before this, have taken a notion to remain solid on the hills later than usual, and then to slide down where they were never known to slide before. The Silver Fortune slide, near the property of the Mascot Mining Company, split above the tunnels and part of it came crashing and roaring down upon the blacksmith shop and ore house, causing damage that will take some time to repair. The slides were piled up in solid masses to the depth of 20 to 30 feet.

#### Court Puts Horse on Witness Stand

"Jim", a horse who had been sold by a blacksmith to a junk dealer for \$45, was an important witness in a case recently tried in Spokane, Washington. His new owner failed to get acquainted with Jim and he immediately brought suit to recover the original purchase price of the critter.

After both sides had testified, one claiming that the horse was as meek and docile as a lamb and the other picturing him as a goat without horns, the judge, in desperation, ordered the court to adjourn to the street, where an impromptu wit-

ness stand was established in behalf of the horse.

"We will now let the horse testify in his own behalf," said the attorney who represented the blacksmith. But either Jim took a sudden dislike to legal proceedings or suddenly became too modest to take the stand, for neither the kindly judge, attorneys, or principals in the case could entice Jim to "testify". In fact his actions were so absolutely childish for a horse, that the case was decided in favor of the junk dealer and the blacksmith had to take back the horse and refund the money.

#### Blacksmith's Son In Irish Rebellion

John Kilgallon, the son of a Far Rockaway blacksmith, has just returned from England, where he had spent a year in a British internment camp following his arrest for participation in the Sinn Fein rebellion.

#### Blacksmiths Continue to Raise Prices

We have been literally swamped with reports from all sections of smiths boosting prices for their work. Steadily rising markets in the iron and steel trade have forced up manufacturing costs of nearly every product which enters into the blacksmithing business. We know that some manufacturers have actually been selling at a loss for some time, withholding a rise in prices in hopes that abnormal conditions would soon pass and normal levels of raw materials be regained. Now, however, indications point to high costs continuing, and even higher prices may be made necessary, particularly among concerns who have been absorbing the increased cost of materials in their profits and making no advance in price.

The following will give an idea as to the price situation in various sections of the country:

The blacksmiths of Ogdensburg, N. Y., recently had a "get-together" for a discussion of conditions and resolved to advance all prices on a standard basis, to cover the added expense of material. No scale of prices has yet been adopted to our knowledge, but we understand that it will provide for a good profit over and above the present costs.

Horseshoeing and general smithing prices are to be raised in the towns of Norfolk and Bristol, Connecticut, as a result of a meeting of the Norfolk and Bristol Counties' Association.

The Master Horseshoers of California have planned to raise shoeing prices again, this time 50 cents a set.

A wage agreement, affecting over 8,000 master horseshoers and 11,000 journeymen in 400 cities throughout the United States, makes effective an increase of wages, so that from \$3.50 to \$5.00 a day will hereafter be demanded for work, depending upon locality.

A higher schedule of prices has gone into affect in Great Barrington, Mass. The new schedule is as follows:

Common shoeing, Nos. 1, 2, 3 and 4, \$1.50; Nos. 5, 6 and 7, \$1.75; resetting shoes, \$1; bar shoes, 75 cents each; leather pads, 50 cents each. All light and fine shoeing will be charged extra.

Six of the leading blacksmiths of Middletown, N. Y., have announced price increases which became effective on April 1. The increase is attributed to increased cost of materials. The new schedule follows:

Four new shoes, No. 0 to 5, \$1.60; four

new shoes, No. 5 up, \$2; four shoes set, No. 9 to 4, \$.80; four shoes set, No. 5 up, \$1; four shoes calked No. 0 to 4, \$1; four shoes calked, No. 5 up, \$1.25.

The announcement is made that the shops are to close on Saturdays at 12 o'clock noon.

#### Australian Blacksmith-Boxer Becomes U. S. Citizen

Les Darcy, the Australian middleweight boxer, whom Governor Whitman barred from boxing in New York State because, he said, Darcy was a "slacker," evading Australian military service, took the oath of allegiance and signified his intention of becoming a citizen of the United States today. He received his first citizenship papers from the Circuit Court of Cook County.

Darcy gave his age as twenty-one years and his occupation as a blacksmith and professional athlete. He gave his home as Maitland, Australia.

#### Over 100,000 Blacksmiths Ready for Uncle Sam

Two hundred members of the Indiana Master Horseshoers' Protective Association met in convention on April 10th and pledged the services of 10,000 skilled horseshoers for army service.

The Ohio Association has passed a resolution approving the government's efforts for preparedness, and has sent a message to President Wilson pledging the loyalty and service of the 100,000 members of the association.

#### Other Blacksmiths Show Patriotic Spirit

Members of the local Dunkirk, N. Y., Brotherhood of Blacksmiths and Helpers adjourned an important business meeting, early in April, to march in a body to the Lyceum and there participate in an enthusiastic and highly patriotic demonstration. They made a splendid showing with a strong body of men headed by the local Moose band.

Fred Hoffmann of Pennsylvania has given up his position in the Lehigh Valley shops to assume charge of the blacksmith work at Battery A Armory, Hazleton, Pa.

#### Blacksmith gets a real Gold Brick—and Then Some!

Michael Sheean, a blacksmith in the Chicago mine near Juneau, Alaska, is being held in connection with a shift boss from the same mine on a charge of the theft of a gold brick valued at \$20,000.

The gold brick has not yet been found.

#### Blacksmith throws humane officer Out of Shop

When he tried to remonstrate with a smith in Omaha, Neb., special Humane Officer J. F. Wheeler was forcibly ejected by the smith. The anvil hitter was gently massaging the hind legs of a horse he was shoeing with a heavy iron bar.

He was fined \$1 and costs on the charge of being cruel to dumb animals.

#### Killed in Blacksmith Shop

After joy-riding on a motorcycle, Clyde Hopkins, of Kendallville, Ind., piloted his machine head-on into a blacksmith shop, and was killed.

It is hardly necessary to point out the foolishness of an escapade of this kind. One is very likely to get into trouble hitting anything head-on and surely a blacksmith shop is one of the last places to pick out for this purpose. One is so likely to hit an iron bar or other substance of similar unyielding texture.



## Another Village Smithy

Beneath the spreading chestnut tree  
The Village smithy stands,  
The Smith, a lazy man is he,  
With time upon his hands.  
(Must have been wearing a wrist-  
watch!)

He waits but for a chance to rob  
The first poor cuss he can,  
He wants the whole world for a job,  
And soaks most any man.

And he is quite a wealthy soul,  
In ease and wealth he fares,  
For he has made a large, fat roll  
In motor car repairs!

—Louisville (Ky.) Times.



## Heats, Sparks, Welds

Overhead and swelled-head sometimes go together. A good remedy for both is a little sweat.

One of the blessings of ignorance is that folks who didn't know a thing couldn't be done, just go right ahead and do it!

Make your competitors jump, by putting all your energy, knowledge and skill into your own work instead of knocking him, his business and his skill.

Lots of our boys are taking up wood-working these days. We wonder if it wouldn't help a bit if they added "head-working" as a side line. What?

It's a temptation to take a job at cut prices—"just to keep busy". And like most other temptations, it's dangerous; it's so easy afterwards to do it again.

There are lots of funny things in this li'l ol' world, but why is it that a "keen" business head does not cut prices as readily as one that's dull? There's a reason.

Stimulate your cash business by giving five percent discount for prompt payment. Some smiths say it solves the long credit problem. Try it in any event you'll be the gainer.

Did you ever hear of a business man winning success by poking his nose into the business of his competitors? Business success is the result of paying strict attention to your own business.

It's a matter of just plain business, not sentiment. Collect sharply, buy closely, insist upon a fair profit and do good work. If you do these things, you will not be able to keep success from your door.

Although they say buffaloes are fast becoming extinct, we still have a goodly supply in our "corral." Better write in

for a herd—just ask for your supply of Pink Buffalo Stamps. Don't fail to use them freely.

Some folks don't believe in crossing the bridge before they come to it. And they are often the ones who advertise only when they put up a notice that the old shop is for sale—or let the sheriff do the advertising for them.

There is a happy medium, find it and then stick to it. Some smiths seem to forget that their one and only reason for being in business is profit, while others allow the sight of profit to blind them to their obligations and promises to customers.

Just because there's war in the air is no earthly reason why the sturdy knights of the hammer and tongs should get in a stew over it. There never was a time when we should all be more calm and tend more strictly to business and less to talk than just now.

Are you one of the thirty or more smiths who have contributed to this issue? How long must we wait before being favored with something from your pen or pencil? It is not necessary to be a literary genius—get your ideas on paper, and we will do the rest.

Ever notice the difference between one of those clear, bright spring days and one that's clouded over? How about wearing a cheery, bright smile once in awhile just to help light up the shop and keep your customers in that frame of mind that makes them want to come again.

A mine may be worth a lot—when it is worked. But it pays nobody unless he gets busy and digs. You can apply the same line of reasoning to your craft paper. It's a regular gold mine for the progressive blacksmith. But it takes digging to extract all of the pure metal.

Buying cheap materials to save money is poor policy. It's like stopping a watch to save time. You can buy economically—wisely, shrewdly; but there's a difference between driving a good bargain, and purchasing supplies that are cheap through and through—things that will cheapen your work and your Rep.

Side lines are all right and have the sanction of the law and the community, if of the right kind. However, we hear of one smith recently who opened up a lottery department in connection with his smith shop, and naturally the big arm of the law quickly crushed his ambition to install a profitable (?) side line.

Next Time you tackle a job in the same old way, try using your head just to see if there isn't some new way in which you could improve your work and save yourself time and effort. A single machine may do the work of ten men, but it takes a man to make a single machine. Don't be a machine—brainless, thinkless; be a man.

Have you ever succeeded in hammering two jobs at once? Then why knock your competitor? Better hammer your own anvil and if there's any knocking to be done, take it out on yourself. Then perhaps you will discover a few faults that even a rival knows nothing about. It's all in line with better business methods, a finer spirit and bigger, broader craft organization.

Don't take the wrong, up-side-down view of life. Remember that many a Ford is envied by a wheel barrow. Your troubles are not the most pernicious ones. Some poor guy would exchange and be glad to pay the boot. Just keep a-plug-

ging. The moon changes every quarter and when the man up there does get full he shines with much glory. Your day will come. So cheer up and get a grin.

T'other day Old Timer handed us this one: "Your brain needs exercising—ventilate it." Now just what he meant didn't soak in until after he had gone. We couldn't quite see the connection. Then it suddenly dawned upon our mildewed consciousness that perhaps he had in mind letting new thoughts and fresh ideas filter in. That seemed like pretty good advice to us, so we pass it on to you.

We have had quite a few letters during the last month telling us about how some of the boys have been taking up side lines. No doubt many of our readers are veterans at handling work other than shoeing and jes' smithin', and we surely would like to hear from them, and how they are making out with their side lines. If you have taken on welding, auto repairing, painting, wood-working, or even such things as clock repairin' an' the like, write us about it. We want real experiences—not just imaginings.

Most anvil hitters would laugh at the idea of a gymnasium for blacksmiths. And we would have to join in the fun. We can just imagine a brawny son of Vulcan toiling with a couple of 60 pound dumb bells, etc! But "those as has any brains at all" will do well to think about taking a little gym work once in awhile for their mental muscles. A craft paper serves admirably as a gymnasium for husky smith brains, with its discussion of kinky problems, etc. A little exercise once a month will keep your head piece in fine temper.

To men interested in lumbering, the Georgia State College of Agriculture at Athens, Georgia, is offering what they term a Lumberman's Short Course. We understand that this course fits a man for such jobs as woods' foreman, yard boss, scaler, cruiser or surveyor; and the chance of competing under Civil Service Examinations for the position of Forest Ranger. There is no tuition, and we believe this course offers a splendid opportunity to men desiring a change. Full particulars will be mailed by writing direct to the address above.

Habit is the easiest thing a human being can acquire. When a customer has to go from your shop with a job you couldn't handle because of insufficient or antiquated equipment, chances are he will form the habit of going to the other fellow later on with his ordinary work. After your customers have formed the profitable habit of doing business with you, don't let them lose the habit. If they buy autos or tractors to keep company with their horse fleets, see to it that you are properly equipped to "shoe" their "new animals."

Ever stop to think that Sandy McKay over in Glasgow, and Michael O'Shaughnessy down in Melbourne are reading this self-same paper you are now holding in your hands? And that some kink of yours or a brother blacksmith may be just the thing they are looking for? There are readers in all parts of the world who read Our Journal, and if each one wrote in just once in awhile, telling us about how they have solved some tough shoeing problem, or send in some kink of theirs, what a fund of knowledge would be added to the blacksmith business. You, yourself, can start the ball rolling by sitting down today and writing us. Do it now, while you have a spare moment.



# Our Honor Roll

### IT'S EASY NOW TO BE AMONG THE LEADERS.

Do you want to place your name among the leaders? It's easy now. If your subscription expires with the May, 1917, number, send in a little five spot (\$7.00 in Canada or 1£ 14 sh. in other countries) and your name will be placed in the May, 1917 class and you won't need to think about your subscription account for years to come. There are only a few subscribers whose subscriptions are paid up to 1927. Put your name in that group. It's easy if your subscription expires this month—May, 1917.

If it doesn't expire this month, ask the Subscription Department when it does expire and how you can get into the leaders' class.

### A NEW NAME IN FIRST PLACE!

This month Kansas takes the lead. The Fix-It Shop held first place for several months until it got Kansas' goat and Mr. Krehbiel came across with an order for 20 years! Who'll be next? Maybe it will be Missouri—or New Zealand, who knows? Just keep your eye on this Honor Roll and see what'll happen next month.

U. S. and Mexico		Canada		Other Countries	
2 yrs.....	\$1.60 save \$ .40.....	\$2.00 save \$ .50.....	10 sh. save 2 sh.		
3 yrs.....	2.00 save 1.00.....	2.70 save 1.05.....	14 sh. save 4 sh.		
4 yrs.....	2.50 save 1.50.....	3.20 save 1.80.....	18 sh. save 6 sh.		
5 yrs.....	3.00 save 2.00.....	3.75 save 2.50.....	1 £ save 10 sh.		
10 yrs.....	5.00 save 5.00.....	7.00 save 5.50.....	12 14 sh. save 1£ 6 sh.		

Send your order and remittance now—today. Don't wait until you forget all about it. You'll never regret it. Our subscription insurance saves you money. The sooner you begin saving, the more you save. There is no better time than NOW.

NAME	Subscription Paid to	NAME	Subscription Paid to
E. A. Krehbiel, Kans.	May, 1937	V. Priesnitz, Wisc.	Mar., 1926
The Fix-It Shop, Utah	July, 1935	E. Price, Illinois	Feb., 1926
J. A. Torray, Mass.	Dec., 1933	D. C. Garber, Ohio	Feb., 1926
W. C. Watt, Kansas	Dec., 1930	J. H. Kurt, Illinois	Feb., 1926
I. J. Stites, N. Y.	Jan., 1929	E. R. Hitzhus, Ohio	Feb., 1926
Waddington Farm, W. Va.	Mar., 1928	H. F. Schreiber, Pa.	Feb., 1926
A. MacLean, Ont., Can.	Feb., 1928	J. S. Damm, Iowa	Jan., 1926
W. W. Egly, Pa.	June, 1927	J. M. Withers, Hawaii	Jan., 1926
E. A. Krehbiel, Kan.	May, 1927	D. Teeblin, Nebr.	Dec., 1924
S. Forman, N. J.	Apr., 1927	N. B. Quick, Pa.	Dec., 1924
H. Dyressen, S. D.	Apr., 1927	F. H. Jarvis, Indiana	Dec., 1924
F. Roehy, Pa.	Feb., 1927	George Tatun, Jr., Fla.	Dec., 1924
J. W. Howes, Md.	Feb., 1927	L. Clark, Va.	Dec., 1924
W. Stocker, Texas	Feb., 1927	A. N. Estes, Va.	Dec., 1924
W. Pontius, Iowa	Feb., 1927	J. Bailly, Manitoba	Dec., 1924
M. Goller, Pa.	Feb., 1927	E. G. Naylor, Md.	Dec., 1924
A. McLean, Nev.	Feb., 1927	Halvorsen Brothers, S. D.	Nov., 1924
C. M. Adams, Conn.	Jan., 1927	P. Schicka, Washington	Nov., 1924
C. Radelef, Iowa	Jan., 1927	H. E. Snyder, Oregon	Nov., 1924
A. H. Gooding, S. Aust.	Dec., 1926	J. A. Stewart, Ky.	Oct., 1924
H. Pass, Minn.	Dec., 1926	C. Richsacker, N. Y.	Oct., 1924
A. Granadam, Ill.	Dec., 1926	W. L. Bertholf, N. J.	Oct., 1924
Platinum Shoeing Shop, Colo.	Dec., 1926	J. W. Hewson, S. Africa	Sept., 1924
C. J. Hale, Wash.	Dec., 1926	Ed. Larson, N. D.	Sept., 1924
John H. Schneider, Cal.	Dec., 1926	R. T. Monk, Illinois	Sept., 1924
J. C. Smith, Washington	Dec., 1926	W. T. De Young, Illinois	Sept., 1924
H. Grimm, Utah	Dec., 1926	C. W. Taylor, Pa.	Aug., 1924
F. L. Matlocks, Ark.	Sept., 1926	Charles Wells, Colorado	Aug., 1924
E. B. Jones, Wisc.	Sept., 1926	H. G. Weaver, Pa.	Aug., 1924
J. Taylor, Calif.	Oct., 1926	Working Men's College, Vict.	June, 1924
W. H. Branch, N. C.	Oct., 1926	F. M. Kenoyer, Nebr.	June, 1924
J. Clarke, Jr., Queens, Aust.	Aug., 1926	O. Anderson, Ariz.	May, 1924
I. Boles, Ohio	July, 1926	R. C. Frederick, N. D.	May, 1924
J. A. Bachner, Mich.	July, 1926	H. L. Fenton, New Mexico	May, 1924
H. Mitchell, N. Y.	July, 1926	J. Carl, Iowa	May, 1924
M. Broton, N. D.	June, 1926	J. E. Little, Pa.	May, 1924
A. Schmitt, Nebr.	June, 1926	H. I. Brenzle, N. Y.	Apr., 1924
D. Ackland & Son, Man.	May, 1926	W. E. Parr, Iowa	Apr., 1924
H. Pirret, Ore.	May, 1926	F. Sramek, Nebr.	Apr., 1924
J. Sinclair, W. Australia	May, 1926	L. A. Hulan, Calif.	Apr., 1924
P. Bova, Oregon	May, 1926	J. E. Ray, Minn.	Mar., 1924
E. P. Dignan, S. Australia	Apr., 1926	A. Hulstrand, N. D.	Mar., 1924
P. A. Peterson, Iowa	Apr., 1926	W. F. Riske, Wisc.	Mar., 1924
G. F. Bowers, Okla.	Apr., 1926	P. F. Selbert, Calif.	Mar., 1924
W. Poehel, Oregon	Mar., 1926	H. Roeschwetter, Mo.	Mar., 1924
A. Garver, Ohio	Feb., 1926	W. B. Briant, N. J.	Mar., 1924
C. Burton, Mass.	Mar., 1926	A. Bosch, N. Y.	Mar., 1924
J. Murphy, Calif.	Jan., 1926	D. Van Valkenburg, Mass.	Feb., 1924
J. F. Murphy, Nev.	Jan., 1926	A. R. Johnson, R. I.	Feb., 1924
F. Keames, Illinois	Jan., 1926	F. Jacobs, Ohio	Feb., 1924
J. N. McIntire, Pa.	Jan., 1926	A. J. Perry, Illinois	Jan., 1924
W. Post, N. Y.	Jan., 1926	E. K. Walker, Calif.	Jan., 1924
J. Murphy, Calif.	Jan., 1926	H. D. Erskine, Vermont	Jan., 1924
Powell Brothers & Whitaker, Eng-land	Jan., 1926	E. Fowler, Pa.	Jan., 1924
O. Temple, Idaho	Jan., 1926	Breen & Son, Ireland	Dec., 1923
N. Karolowicz, S. Dak.	Jan., 1926	M. Lamoreaux, Ohio	Dec., 1923
E. L. Lahn, N. Y.	Dec., 1925	C. R. Davis, N. Y.	Dec., 1923
J. A. Hulvy, Illinois	Dec., 1925	F. W. Copeland, Kansas	Dec., 1923
Williams & Turner, W. Va.	Dec., 1925	J. L. Tomlin, Kansas	Dec., 1923
J. J. Devins, N. J.	Dec., 1925	H. A. Davis, N. Y.	Dec., 1923
P. Nelson, Minn.	Dec., 1925	E. H. Troyke, Illinois	Dec., 1923
M. Kennedy, Tas., Australia	Dec., 1925	D. B. Johnson, Iowa	Dec., 1923
H. Jones, England	Dec., 1925	S. Horton, Calif.	Nov., 1923
A. J. Wassmans, Idaho	Nov., 1925	J. Spratt, Mass.	Nov., 1923
J. G. H. Mallett, Queens, Australia	Nov., 1925	F. Watkins, N. H.	Nov., 1923
A. W. Sperl, Ohio	Nov., 1925	F. Koppnis, Ala.	Nov., 1923
W. R. Clapper, Texas	Nov., 1925	Y. C. Lienert, S. Australia	Oct., 1923
G. H. Laley, Mass.	Nov., 1925	W. B. Abell, N. Y.	Oct., 1923
L. Krause, Ind.	Nov., 1925	A. R. Turner, Man.	Oct., 1923
Raynolds Brothers, Pa.	Sept., 1925	W. J. Brookman & Co., Vict., Aust.	Sept., 1923
F. W. Kraus, Calif.	Aug., 1925	C. Nelson, Nebr.	Sept., 1923
C. E. Allan, Nebr.	Aug., 1925	J. Hughes, Ohio	Aug., 1923
A. E. Spangberg, Oregon	May, 1925	H. M. Anderturen, Calif.	Aug., 1923
D. M. Kile, Okla.	Apr., 1925	Camp Brothers, Texas	Aug., 1923
G. Mullgren, Iowa	Apr., 1925	L. C. Larson, Iowa	July, 1923
G. Fredericks, Minn.	Mar., 1925	S. Effner, South Africa	July, 1923
		G. L. DeWitt, Mont.	July, 1923
		W. W. Gregg, Texas	July, 1923

NAME	Subscription Paid to
W. R. Stroupe, N. C.	July, 1923
O. C. Young, Michigan	June, 1923
Otto Sippel, Pa.	June, 1923
A. Chapman, N. Y.	June, 1923
C. Birely, Md.	June, 1923
F. H. Stoupe, Pa.	June, 1923
J. C. Stover, Pa.	Apr., 1923
W. Schoonover, Pa.	Apr., 1923
J. M. Rumble, Iowa	May, 1923
Lowndale Brothers, Mo.	Mar., 1923
J. Carswell, Ark.	Mar., 1923
G. E. Glazier, Ohio	Mar., 1923
F. Gath & Co., S. Africa	Mar., 1923
T. Bradley, N. S. Wales	Mar., 1923
L. T. Needham, Illinois	Feb., 1923
G. C. Disinger, Miss.	Feb., 1923
J. Wieber, Minn.	Jan., 1923
Z. A. Enos, Minn.	Jan., 1923
W. G. Wise, Calif.	Jan., 1923
F. S. Bishop, South Africa	Jan., 1923
J. Curran, Arizona	Jan., 1923
S. P. Harney, Mont.	Dec., 1922
W. Breckner, Okla.	Dec., 1922
J. Fabina, Nebr.	Dec., 1922
P. Frederickson, Iowa	Nov., 1922
L. O. Louisa, Illinois	Nov., 1922
W. Lawson, New Zealand	Nov., 1922
W. O. Grant, Calif.	Oct., 1922
W. H. Miller, Iowa	Oct., 1922
J. S. Lee, Wash.	Sept., 1922
A. O. Martin, Idaho	Sept., 1922
O. A. Mortimer, Idaho	Sept., 1922
H. J. Hyatt, Washington	Sept., 1922
J. N. Skow, Iowa	Sept., 1922
A. D. Standiford, Washington	Sept., 1922
T. Temkiewicz, Quebec	Sept., 1922
A. Felfler, Ohio	Aug., 1922
W. D. Valentine, Iowa	Aug., 1922
G. Hoffman, N. Y.	July, 1922
J. Erman, Ark.	July, 1922
W. K. W. Hansen, Pa.	June, 1922
Robert Tachter, Calif.	June, 1922
J. Van Marter, N. Y.	June, 1922
E. Schnelle, Ohio	Apr., 1922
J. Bunker, Iowa	Jan., 1922
F. Norris, Yukon Ty.	Jan., 1922
J. Needham, Kans.	May, 1922
E. Anders & Son, S. Australia	May, 1922
Louisa Carriage Works, Va.	May, 1922
S. Smith, Texas	Apr., 1922
M. Burke, Ariz.	Mar., 1922
J. W. Hodge, N. Y.	Mar., 1922
J. W. Haar, La.	Mar., 1922
D. W. Smith, La.	Mar., 1922
D. W. Smith, Rhode Island	Mar., 1922
E. A. Dillon, Nev.	Mar., 1922
D. F. Kuster, Washington	Mar., 1922
V. Vanouret, Wisc.	Feb., 1922
W. Parker, Mich.	Feb., 1922
J. DeGlopper, Mich.	Feb., 1922
Nordstrom Bro., Kans.	Feb., 1922
G. F. Johnson, Michigan	Feb., 1922
J. Schoenberger, Ohio	Jan., 1922
A. Burgett, Pa.	Jan., 1922
R. H. Keith, Iowa	Jan., 1922
W. Parks, Ohio	Jan., 1922
O. Dannemann, Minn.	Jan., 1922
O. Stenning, S. D.	Jan., 1922
C. F. Shaw, Man., Can.	Dec., 1921
W. Bisker, Ohio	Dec., 1921
W. Lambertson, N. Y.	Dec., 1921
Scheffely & Schmitt, Pa.	Dec., 1921
O. Furry, Kans.	Dec., 1921
E. A. Pierson, Okla.	Dec., 1921
J. Robertson, Scot.	Dec., 1921
J. Lauer, Mo.	Dec., 1921
A. Brause, Ohio	Dec., 1921
B. A. Abbey, Ohio	Dec., 1921
J. Ingvarson, Minn.	Dec., 1921
A. F. Milldebrandt, Mich.	Dec., 1921
R. H. Teufel, Jr., Ill.	Dec., 1921
R. C. Brown, Mo.	Dec., 1921
C. Beyer, N. D.	Dec., 1921
G. Nichols, Okla.	Dec., 1921
F. H. Joslin, Mass.	Dec., 1921
J. B. Scheidler, Indiana	Dec., 1921
J. E. Ickes, Pa.	Dec., 1921
J. E. Wilks, Colorado	Dec., 1921
J. Beam, N. J.	Nov., 1921
F. Kolarik, Iowa	Nov., 1921
A. McNab, Scot.	Nov., 1921
J. Delane, Nebr.	Nov., 1921
A. Marks, N. S. W., Aust.	Nov., 1921
O. R. Stevenson, Ill.	Nov., 1921
J. Meier, Minn.	Nov., 1921
W. Knouff, Ala.	Oct., 1921
O. M. Johnson, Miss.	Oct., 1921
J. K. Glinicki, Mich.	Sept., 1921
H. Feldus, Nebr.	Sept., 1921
R. Murray, Calif.	Sept., 1921
A. Hammond, Calif.	Sept., 1921
P. Wedel, Kans.	Sept., 1921
J. Ackerman, Indiana	Sept., 1921
A. Harper, Mont.	Aug., 1921
L. E. Bouton	Aug., 1921
J. Watson, S. Africa	July, 1921
R. Goldschag, S. Afr.	July, 1921
C. Hammerstram, Minn.	July, 1921
A. S. Pratt, New York	July, 1921
E. H. Spain, Ariz.	July, 1921
L. H. Strange, Vict., Aust.	July, 1921
W. Urquhart, New Zealand	June, 1921
W. Voigt, S. Afr.	June, 1921
J. M. Werl, Pa.	June, 1921

NAME	Subscription Paid to
E. Toll, New Zeal.	June, 1921
G. Johnson, Kans.	May, 1921
S. Budde, New Guinea	May, 1921
H. Baker, Aust.	May, 1921
F. E. Smith, Vermont	May, 1921
A. J. Hatch, Maine	May, 1921
W. Corwell, Pa.	May, 1921
W. F. Kline, Kansas	May, 1921
J. Kirkbride, N. J.	May, 1921
T. Holloway, Kans.	Apr., 1921
W. Winget, Vt.	Apr., 1921
J. A. Johnson, N. D.	Apr., 1921
D. H. Laird, N. Y.	Apr., 1921
A. J. Prue, N. Y.	Apr., 1921
C. A. Butler, Ohio	Apr., 1921
E. Moesner, Queens, Australia	Apr., 1921
F. Bowen, N. Y.	March, 1921
W. F. Tippey, Mich.	Mar., 1921
J. T. Rehm & Son, N. Y.	Mar., 1921
W. C. LeBow, Mo.	Mar., 1921
William Pat, Mo.	Mar., 1921
A. T. Jameson, Colorado	Mar., 1921
C. Alexander, N. Y.	Mar., 1921
J. Fencil, Wisc.	Mar., 1921
H. Cornils, Oregon	Mar., 1921
C. Schmid, Nebr.	Mar., 1921
J. Schwarzmann, D. C.	Mar., 1921
M. Stettner, Minn.	Mar., 1921
N. E. Hart, Okla.	Feb., 1921
C. Knudson, Iowa	Feb., 1921
S. Button, Kans.	Feb., 1921
N. F. Hartsoe, Mo.	Feb., 1921
I. Qoeprle, N. Y.	Feb., 1921
E. E. Worthington, N. Y.	Feb., 1921
B. E. Doggett, Kansas	Feb., 1921
Shellhas & Fry, Colorado	Feb., 1921
J. Tooes, Kansas	Feb., 1921
J. W. Wilson, Mo.	Feb., 1921
W. T. Wilson, Indiana	Feb., 1921
J. Schmid, Nebr.	Feb., 1921
E. Sies, New York	Feb., 1921
A. R. Skeritt, New York	Feb., 1921
W. H. Starkey, Kans.	Feb., 1921
W. Singleton, Pa.	Feb., 1921
E. N. English, Iowa	Jan., 1921
H. Becker, Ill.	Jan., 1921
G. Tice, N. J.	Jan., 1921
J. Briere, Vt.	Jan., 1921
A. Bartlett, Vt.	Jan., 1921
E. H. Manley, Mo.	Jan., 1921
Neufeld & Giesbrecht, Kans.	Jan., 1921
W. C. Abbott, Ohio	Jan., 1921
Feldmeyer & Schaeke, Mo.	Jan., 1921
A. Joespitt, Colorado	Jan., 1921
C. L. McCall, Mo.	Jan., 1921
A. Turley, Kansas	Jan., 1921
A. Seidel, Nebr.	Jan., 1921
W. Buple, Pa.	Jan., 1921
N. A. Englund, Iowa	Jan., 1921
O. Gerhardtstein, Ohio	Jan., 1921
W. C. Butler, Illinois	Jan., 1921
J. L. Jester, Mo.	Jan., 1921
G. A. Moffatt, Yukon Ty.	Jan., 1921
F. Fisher, S. D.	Jan., 1921
A. L. Schwartz, Iowa	Dec., 1920
S. Barber, Iowa	Dec., 1920
A. Warner, Idaho	Dec., 1920
J. W. Ivie, Utah	Dec., 1920
O. A. Huff, Pa.	Dec., 1920
J. T. Rowe, Iowa	Dec., 1920
W. Parsons, Ontario	Dec., 1920
Eisler Brothers, S. Dak.	Dec., 1920
J. Krabulce, Illinois	Dec., 1920
L. F. Kellholz, Pa.	Dec., 1920
F. Markgraf, Minn.	Dec., 1920
S. Wright, New York	Dec., 1920
T. P. Consoide, Mass.	Dec., 1920
J. D. Fox, Nebr.	Dec., 1920
W. Treener, Washington	Dec., 1920
A. G. Palmquist, Minn.	Dec., 1920
J. E. Richards, Pa.	Dec., 1920
J. Berthelsen, N. S. W., Aust.	Dec., 1920
G. Sykes, N. S. W., Aust.	Dec., 1920
B. Billing, N. Y.	Dec., 1920
W. Obergfell, N. J.	Nov., 1920
L. F. Smith, Ohio	Nov., 1920
D. Cedere, Illinois	Nov., 1920
C. Franssen, New York	Nov., 1920
J. Delane, Nebr.	Nov., 1920
J. H. Staates, Mo.	Nov., 1920
George F. Wardle, S. D.	Nov., 1920
H. C. Strine, Pa.	Nov., 1920
C. M. McNeill, Mass.	Nov., 1920
J. M. Mapes, New York	Nov., 1920
W. Condon, New York	Nov., 1920
F. Strief, Wis.	Nov., 1920
L. P. Mortensen, Michigan	Nov., 1920
A. W. Brenneman, Indiana	Nov., 1920
J. Gribble, S. Aust.	Nov., 1920
R. L. Whitfield, N. S. W., Aust.	Nov., 1920
McFarlane & Pratt, S. Africa	Oct., 1920
Thomas Scurr, New Zealand	Oct., 1920
W. H. Finlay, New Zealand	Oct., 1920
J. Hawn, N. J.	Sept., 1920
C. L. Massey, Ark.	Sept., 1920
J. Jordan, Cal.	Sept., 1920
J. Jordan, Cal.	Sept., 1920
L. O. Breke, Washington	Sept., 1920
R. D. Simkins, Penna.	Sept., 1920
A. E. Reece, Mass.	Sept., 1920
L. E. Garvin, Ohio	Sept., 1920
T. Smart, Mo.	Sept., 1920
F. V. Robinson, W. Va.	Aug., 1920
W. F. Farey, Iowa	Aug., 1920

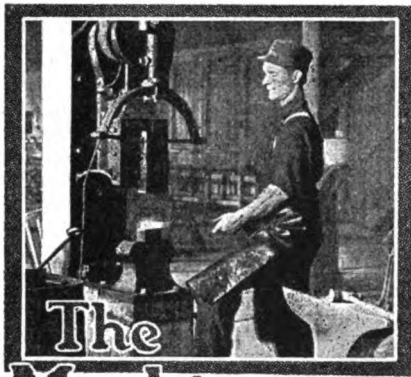

## The Machine and Tool Smith

### Fundamentals of Lathe Practice

JAMES STEELMAN  
Brass on the Lathe

The turning of *brass* presents some variations. Attention has already been directed to the advisability of using a small top rake angle with the cutting tool. In fact, this angle may be made nothing at all. That is, the top surface of the cutting edge may be flat and horizontal. It should, ordinarily, be on a level with the axis of the work—that is, on a level with a line joining the tip of the head stock center and the tip of the tail stock center. But the name *brass* covers a multitude of metals running all the way from soft, yellow metal up to hard, dark colored material. The softer the metal, the less the angle of top rake is a good, general rule.

The cutting speeds to be used are much greater than when cutting machine steel, cast iron or tool steel. I will give some figures; but one must remember that brass varies in hardness. The figures may be regarded as suited to brass whose hardness is about the average. For very soft metal the figures may be increased, somewhat, though perhaps not a great deal; and for very hard metal, less speeds may be used. Furthermore, it appears permissible to some that the diameter of the work should affect the speed with which the chip is stripped off. For brass, then, having a diameter of  $1\frac{1}{2}$  inches, a cutting speed of 80 feet per minute may be adopted. This is in the neighborhood of twice the speed to be used with cast iron. Note that we are considering, not the number of revolutions per minute, but the actual rate at which the work passes the cutting edge. We have already had explained in effect

the relation between the revolutions per minute and the rate at which the work is moving along at the point where the chip is coming off. To get 80 feet per minute with a *radius* of 3-4 inch (diameter of  $1\frac{1}{2}$  inches) would require the lathe spindle to turn at the rate of 204 rotations per minute.\*

If the work is  $1\frac{1}{4}$  inches in diameter, we may speed up a little and do the cutting at the rate of 90 feet per minute. So, likewise, with work having diameters of 1 3-4 inch, we may speed up to 100 and 110 feet per minute, respectively. To get 90 feet per minute with a 5-8-inch radius, 275 rotations per minute would be necessary; to get 100 feet with a  $\frac{1}{2}$ -inch radius, 385, and to get 110 feet with a 3-8-inch radius, 561.

#### The Cut Meter

If we have an instrument called a *cut meter*, we may hold it up against the brass work and tell whether we have the lathe speeded up sufficiently to give the right number of feet per minute for the rate at which the work is passing the cutting edge. In short, we may use such an instrument, not merely for testing whether our calculations have been made correctly, but also for getting rid of the calculations altogether.

We proceed thus. We hold the instrument in the right hand by its handle in such way as to bring a small wheel belong to the instrument against the work at the location where we propose to begin cutting. There is a kind of dial on the instrument. As the work goes round, we may read off, without any calculation, the rate, in feet per minute, at which the work passes the cutting edge. If the work is going too slow, we shift the belt to a smaller step on the cone pulley belonging to the head stock; if too fast, we shift to a bigger step. Or, if we have other means of changing speeds—as with an individual electric drive—we slow down or speed up. We may use the instrument repeatedly, as the diameter of

\* The calculation may be made as follows: With a radius of  $\frac{3}{4}$  inch, or a diameter of 1.5 inches, the circumference will be  $1.5 \times 3.1416 = 4.7124$  inches. Reducing this to feet by dividing by 12, we get 0.393 foot. This is the length of a chip of one turn of the work. We want to know how many turns there will be in 80 feet. Dividing 80 by 0.393, we get 203.6. So, we say that the work will have to rotate at the rate of 204 rotations per minute in order to pass the cutting edge at the rate of 80 feet per minute.

the cut changes as the work goes on.

#### Speed Indicator Used as Cut Meter

We may, if we choose, rig an ordinary *speed indicator* and get the desired information from it. The speed indicator has a point which is pressed up against the end of a rotating shaft, for example, in order to get its *rotational speed*. The point is introduced into a depression in the center of the shaft end, the idea being to make the point of the indicator turn with the shaft. A hand on the indicator will then point to a location on the dial which will show the number of rotations made from the time the hand was set at zero. When using the instrument, we may first see to it that the hand is at 0. With watch in hand, we press the point gently against the depression in the end of the shaft. The number of turns per minute may be determined at once from the instrument by holding the instrument in position for just 1 minute. Naturally, we may hold it for half a minute, 1-3 minute, etc., only then we will have to multiply the reading we get from the dial by 2, 3, or some other figure, depending upon how long we hold the watch. The foregoing explains how to use the instrument for the purpose for which it is made—namely to ascertain the *number of rotations* per minute. It may often be used to find out the *number of feet* a point on the curved surface of a shaft or a point on the work is moving along every minute. To do this, we rig a little *rubber tired wheel* and slip it over the point of the indicator. It should fit the rod which carries the point sufficiently tightly to carry the rod with it when the wheel is turned round. Suppose now that this little wheel has *when pressed lightly* against the rotating shaft, a diameter of just the size to give a circumference of 6 inches. Consequently, when the wheel turns once, the location on the shaft against which it is pressed will have moved 6 inches—that is, half a foot. The hand on the dial will have moved up 1 rotation. Every unit on the dial *now* means  $\frac{1}{2}$  foot. If we operate for 1 minute, then the reading on the dial (the start having been made with the hand at zero) will tell how many half-feet have moved per minute. What we have to do then, in order to use this arrangement as a cut meter is to double the reading from the dial. If the dial shows 50 in the course of 1 minute, then the location on the shaft is

moving at the rate of (2x50—) 100 feet per minute. Instead of holding the instrument in position for 1 minute and then doubling the reading, we may hold it for 2 minutes and then accept the reading as it is. However, 2 minutes is quite a long time for such a job; it will be better to double the reading. The diameter corresponding to a 6-inch circumference is 1.91 inches. The actual diameter of the rubber tire should be a trifle more than this to allow for the slight pressure.

#### Fine Cuts With Brass

Now with brass, although we use high speeds, we do not use heavy feeds. That is, *we use a thin chip rapidly*. A round-nose tool is suitable where the diameter of the cut to be taken is rather large. This type of tool may be used when we pass slowly along the curved surface of a cylinder with the object of taking metal off of that surface and reducing the diameter. The same tool is suitable for cutting the face of pretty good sized work. This may be required for the purpose of cutting a shoulder on the face. Further, the same tool will be found suitable for cutting a fillet. In cutting the shoulder, we begin on the outer edge of the face and work gradually in to the required position for the shoulder. In all these operations, the axis of the tool may be directed somewhat to the left of a perpendicular to the axis of the work.

#### Cutting Tools for Brass

Instead of the round-nose tool, we may at times use a *front tool*. This tool is substantially identical with the round-nose form except at the nose. A pointed nose is provided instead. The total angle of the point, measured in a horizontal plane when tool is in position, may be anywhere from 50 to 60 degrees.

Generally speaking, brass work on the lathe is machined in the dry state. However, if it is desired to use a die to put a thread on rolled brass or drawn brass—as in the case of brass rods or brass tubes—it may be necessary to use a hard oil. Apparently, the favorable action of this substance is connected more with the prevention of the chips sticking in the die and thus damaging the threads on the work.

#### Knurling Brass

It is often desirable to mill or knurl the edges of brass thumb nuts in order that they may present a roughened surface. This work may readily be done on the engine lathe, if one has the proper *knurling tool*

and *holder*. The knurling tool proper consists of a small wheel mounted in the holding device. The handle of the holder is held by the right hand, the holder being supported by a rest which has been securely clamped in position. As the surface to be knurled rotates in the lathe, the right and left hands of the workman are managed so as to bring the edge of the wheel up against the work. The edge of the knurling wheel is suitably grooved to form the proper knurling on the work as it turns. Naturally, when the finished work is convex, the knurling wheel will have a concave

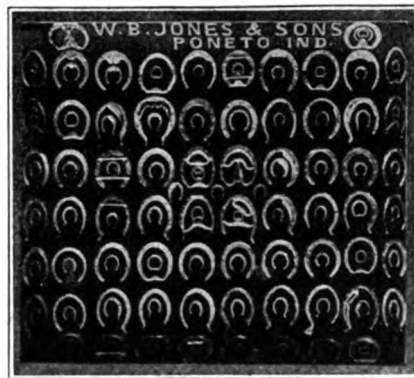

A CASE OF WELL MADE SHOES FROM AN INDIANA SHOP

edge, and *vice versa*. The soft brass is indented and doubtless some of the brass swells, into the cavities of the knurling edge, this swelling being due to the displacement of metal by the projections on the knurling edge. The diameter of the knurling wheel does not have to be different necessarily for jobs of different diameters. The speed recommended for knurling brass in the foregoing way is 300 feet per minute. This means, for work having a diameter of 1 inch that the lathe spindle must turn at the rate of about 1150 rotations per minute. To get this rather fast rotational speed, it may be necessary to provide in some special way. See, for suggestions along this line, the article on Boring and Grinding in the February issue of the AMERICAN BLACKSMITH. If the diameter of the work is smaller yet, then the speed of 300 feet per minute will demand a still faster rotation of the lathe spindle.

Knurling may be done by a knurling tool held by the tool post. It consists essentially of a holder, corresponding to the shank of an ordinary cutting tool, and perhaps two knurling wheels. In using this tool, the tool is fed into the work—perpendicularly to the axis of the

work—in the same way as with an ordinary cutting tool. However, one should make the first effort decisively, pressing the tool rather deeply into the work at once. The longitudinal feed is done with the aid of the lead screw of the lathe. Oil is used on the work and on the knurling wheels.

(To be Continued)

## The Oxy-Acetylene Plant--3

Its Installation, Operation, and Torch

Manipulation

DAVID BAXTER

Preparation

While preheating is one of the most important steps in the process of welding, we will pass up a discussion of it until a subsequent chapter, where it will be fully treated. Preheating is essentially a part of the preparation; it is more than that—it is a subject in itself, and we will view it in that light, sufficing to say in this article that preheating consists of heating the whole or part of a job to a certain degree of heat as determined by various conditions.

There are many things to be kept in mind in the preparation; preparations other than preheating which are absolutely necessary in the majority of cases. It is our purpose in this chapter to bring them to the attention of the operator not alone to give him information on the subject, but to lead him to reason other things out for himself.

*A job well-prepared is half welded.* Careful preparation is vital in the making of a clean, strong weld. It not only saves the operator's time, but gases and filling rods as well, which saving amounts to quite a sizable amount in time.

The line of the crack or break should be thoroughly cleaned of all rust, dirt, or greasy substance. In some cases these accumulations may not be apparent, but are present nevertheless. Therefore, a safe rule to follow is to *clean all parts* to be welded. The cleaning may be done with a wire brush, scraper, file, or, in some instances, with a suitable acid, such as sulphuric. Also the outer flame of the torch is useful in loosening rust and dirt.

If the parts to be welded have been galvanized or plated, this composition should be removed before attempting to add new metal.

The object of cleaning is to eliminate possibilities of any harmful gases contained in the dirt, rust, or other compositions from being absorbed by the molten metal of the





weld; also to eliminate unhealthy conditions arising from gases and odors emitted by the burning substances.

The author knows of an operator who was forced to quit the business on account of his heart being seriously affected. While it is not proven that his work caused the trouble, there was reasonable certainty that it was at least aggravated by the welding operations. It is the author's opinion that the trouble was caused by inhaling fumes from the *pre-heating* and *not* from the welding gases. As natural gas was principally used for preheating, it is reasonable to suppose this was the cause of the heart trouble. However that may be, it is well to be on the safe side and endeavor to eliminate the fumes entirely. If possible use suction fans or other devices.

All parts above an eighth of an inch in thickness should be chamfered or beveled along the broken edges. If only cracked, the line of crack should be grooved its full length, to an angle of ninety degrees, and almost the full depth or thickness of the metal. This grooving applies to nearly all work except sheet metal jobs of a few classes.

The ninety-degree angle is best suited to all classes of work. A wider one makes a greater surface to weld and a weaker weld, and a narrower angle is harder to work in, and also weakens the joint. The grooving gives the operator a chance to break from top to bottom, or the entire thickness of the metal. It is absolutely necessary in making a perfect weld for the two broken edges and the added new metal to flow into one body.

For castings over a half inch thick, it is good practice to groove both upper and lower sides of the break, making the grooves meet to form an "X". The operator can save time and lessen the danger of burning the metal; if he welds one "V" groove, then turns the job over and welds the other side.

The beveling, or grooving, may be done by filing, or grinding. The operator must be careful, however, not to burn the metal by holding it too tight to the emery wheel, providing the part to be welded is small enough to be handled, or does not have to be welded in place. By the latter we mean such jobs as side sheets in fire-boxes, heavy engine beds and so forth.

The grooving is handily accomplished with a diamond point chisel

in cases where it is inconvenient to file or grind out.

In most instances the operator should be careful if the work is done with hammer and chisel, especially on cast metals. This class of work is comparatively fragile and frequently the operator will cause himself double work if he breaks the casting while grooving.

Castings should be clamped together exactly where they belong before welding. While this is the best practice generally, some cases do not require it. The purpose of clamping is to make certain that the broken parts are welded to the place where they belong. Then too, it is often

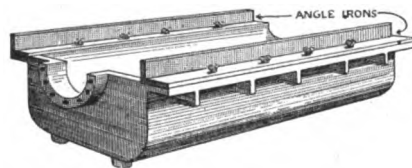

ANGLE IRON BRACES ARE USED TO HOLD BEARINGS IN LINE

necessary to clamp the casting in order that the welding may proceed rapidly and without interruption. Some castings are broken in such a manner as to permit welding without clamping, or are heavy enough to hold themselves in position. An expert will often use clamps to aid him in controlling expansion and contraction, also using it to control or prevent distortion. Sometimes after a wheel has been welded, it will be found that they are not round. This distortion might have been prevented by scientific application of clamps and jacks. Distortion is perhaps more frequent in sheet-metals and requires greater study to be able to control it.

The broken parts may often be clamped or fastened together in a truly scientific manner without costing very much by home-made devices. Sometimes they may be wired so as to hold them rigid, and yet allow expansion without distortion. This is done by wrapping the wire around the casting very much as one would wind string around a ball. It should be done before preheating.

A great many broken parts of machinery have a number of holes which may be used to a great advantage in the clamping process. Where there are no holes, it often occurs that a few holes may be drilled just where they are wanted. These holes may be filled up again by the torch after the main weld is finished. Sometimes holes may be drilled that do no harm if left unfilled.

Frequently it is convenient to use flat bars of iron having holes drilled through them at intervals of an inch their entire length. The broken casting may have a sort of crate or frame work built around it of these flat bolts, fastened together with bolts.

Another handy clamp is formed in a ring of round or square iron about three-eighths of an inch in thickness. One should have a number of these rings, from six to twelve inches in diameter. Squares, triangles, and other shapes are also handy.

To illustrate the use of the ring clamp: suppose the casting is cylindrical and broken in two from end to end. Choose a ring an inch larger in diameter than the broken casting, place the ring around the casting about the centre, then push between the ring and the casting about four small iron wedges. This will hold it firmly and allow preheating and expansion. The square and odd shapes may be used in the same manner. Rings and squares of a diameter of several feet sometimes come in handy.

A leveling or face plate, with numerous holes and slots scattered over its face, proves a convenient arrangement for clamping and leveling small castings that do not need preheating. The broken parts may be fastened to the leveling-plate with screw clamps or bolts. Small crooked castings can be bedded in moist earth or molding sand to hold the pieces together.

Radiation and conduction are enemies to the welding. Where a job is clamped to a metal plate, the loss of heat by conduction through the plate and clamps is greatly increased. This may be partly overcome by having grooves or corrugations in the plate and clamping device, or by padding with asbestos or mica.

The foregoing should furnish the operator with food for thought in devising his own home-made clamping apparatus.

There are a number of devices upon the market, for clamping, or more strictly speaking, holding the broken parts together, but it is difficult to make one machine do all kinds of work; for instance, those which have been devised for special jobs, such as crank-shafts. Where certain parts are to be manufactured or duplicated, it is advisable to have special machines.

Very frequently in welding jobs such as gear-housing, crank-cases, and cylinders, an operator is compelled to contend with the fact



that some part of the casting is missing. A crank-case may have a hole jammed in it and the owner have neglected to save some of the missing pieces.

Part of the preparation is to supply these missing sections, as it is a long and tedious job to build in these parts with the welding torch. If there is a foundry nearby we have an easy solution to the problem. The casting may be taken there and a patch cast in or a missing part molded. Or we may cast in the patch ourselves. Bank the inside of the case full of molding sand or moist earth, now cut away enough of the earth to allow for the metal thickness, place two or three thicknesses of asbestos paper on the outside of the case. Be careful not to press it in too tight to decrease the thickness of the metal, and leave an opening to pour in the molten metal. This scheme only works for metal that is easily melted, such as aluminum, copper, lead etc.

These cast-in parts do not adhere to the original casting, but may be readily stiched in around the edges with the torch. Melt the metal in a babbitt ladle or a crucible.

If the missing piece extends into the bore of a cylinder, a new piece cannot be cast into the cylinder, because the metal coming in contact with the cylinder forms a chilled or hard strip around the cylinder that is impossible to re-bore. If there is no foundry near, the operator may be able to find some other casting or part he can use in place of the missing one.

The author recalls a case where the torch operator used part of a stove-leg to weld onto the shoulder of a broken auto engine cylinder.

A patch or piece to correspond with the lost part may be made of plaster of paris by mixing it slowly with water to the consistency of putty and filling in the space formerly occupied by the lost piece. The plaster will set in a short time, and may then be removed from the casting by cutting or beveling around it. After it is quite dry, pack it in excelsior and ship it to the nearest foundry. Or sometimes it is convenient to make a wooden pattern for the missing part. A metal one can then be cast from this.

The parts cast for patches should be cleaned and grooved and fitted into the casting. They may then be welded in place and will make a stronger, better-looking weld than a patch built in with the torch.

By exercising a little ingenuity the average operator can think out many other ways of preparing the job to save a lot of time and welding gas and also make better welds.

(To be Continued)

## The Care of Tires\*—2

Helpful Hints for the Automobile Repairman

Lubrication is most important to conservation of the tube, but it is a matter that is given least attention. Practically all tire manufacturers treat the inside of cases with a white solution to prevent tubes from sticking to the adhesive "friction" of the fabric—a good lubricant, however, should also be used.

Some repairmen neglect dusting soapstone inside of the case when changing a tube—others use the soapstone so sparingly that it does but little, if any good, or they may use so much that it does more harm than good. If a quantity of it be dumped into the case it will collect at one point, and during the hot weather will heat up to such an extent as to burn the rubber of the tube, making it very thin, brittle and lifeless; this can be recognized by the honey-combed appearance. Soapstone is the lubricant most used for tires and it is quite satisfactory, but not lasting; therefore a fresh supply should be put into the tires at least two or

tubes with specially equipped valves for Clincher cases, another type for Q. D. Clincher cases, and still another type for Straight Side cases. The Clincher valve spreader will not properly lock the Q. D. Clincher beads on a Q. D. Clincher rim, nor the Straight Side type of tire on a Straight Side rim. The valve equipped with a Straight Side spreader will lock the beads on a Clincher rim or a Q. D. Clincher rim, but on account of difference in width and shape may damage fabric of the case.

Don't overlook the importance of a tube with a properly equipped valve. Care in this respect will insure a proper anchor of tire to rim and eliminate much annoyance from tube being pinched near valve.

Pinching of an inner tube usually occurs from oversight or carelessness in application of tire to rim.

Illustration shows how the tube may be caught underneath bed of case. This may occur from putting too much air in tube before application or from not using care to keep tube away from rim until beads of case have been properly engaged in clinches of rim. This may also occur from using a tube of wrong size.—For example, a 4½-inch tube in a 4-inch case. If flap works out of position when the tire is being applied to rim, tube may be injured

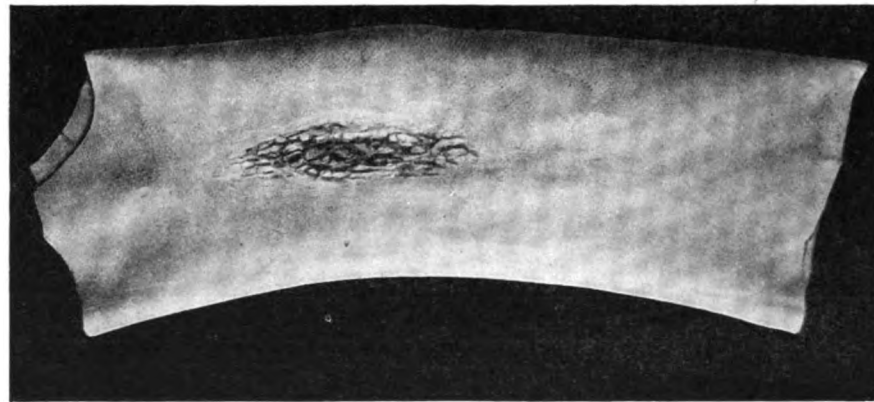

SHOWING THE HONEY-COMBED APPEARANCE OF AN INNER TUBE WHICH WAS BURNED BY SOAPSTONE COLLECTING AT ONE PLACE

three times during the season. Powdered mica has proven a more durable lubricant than soapstone and quite as effective as graphite, as well as more pleasant to handle.

The lubricant should be dusted on the fabric all around the case, and on the inner tube.

It is essential that tubes be equipped with valves having the correct type of spreader. Most companies have, in the past, furnished

by flap or beads of case. When a tire is ridden soft there is a tendency for the beads to lift up at the toes due to the internal pressure and weight of car and sometimes permit tube to work under bead. This is aggravated when the tire has been continually ridden soft and beads have been cut and broken by rim. Don't crowd a tire of wrong size on a rim simply because you are able to do so by physical force. It isn't economy

\* Courtesy Firestone Tire & Rubber Co.



for your customers—aside from the injury to the beads, much annoyance can be expected as the result of tubes being pinched.

All Straight Side and Quick Detachable Clincher cases should be equipped with flaps, and it is important that same be of correct width, length and construction. Detailed information on this subject will be given later.

Not all pinched tubes are injured at rim side—the rubber may be pinched from a rupture in the fabric. For example, a break caused from a small cut or bruise. This is not a serious condition, that is, it will not materially affect the service of tube as repairs can invariably be made in a very satisfactory manner—either by application of patch or when this is not practical a new section of tube can be inserted by a competent repair man.

Tire users do not generally realize the purpose of flaps and the influence of same in relation to tire service.

It is not customary to use flaps with clincher tires, not because it is unnecessary, but because of the difficulty in using a flap and stretching the tire on the rim so that it will fit properly. The beads of this type of

ers are used to hold the beads tightly in clinches of rim so that inner tubes will not be pinched or damaged. The beads of Quick Detachable Clincher cases and cables of Straight Side cases are non-stretchable and are,

procure new ones—the expense is but nominal and the surer protection to inner tube and outer case is worth considering.

While the general design is the same with flaps for Straight Side

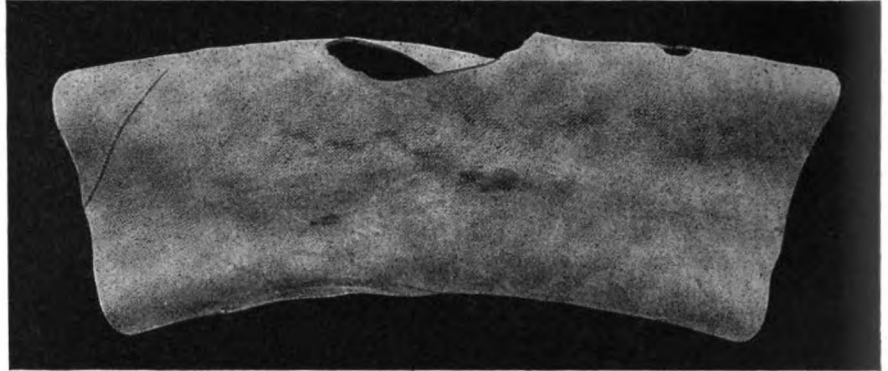

INJURY TO AN INNER TUBE DUE TO THE FACT THAT TOO LITTLE LUBRICANT WAS USED

therefore, made to the approximate diameter of rim. Flaps should be used in all sizes of Quick Detachable Clincher and Straight Side cases, otherwise much difficulty will be experienced with the inner tubes.

Several years ago tire manufacturers cemented the flaps to one side of cases. The heat of tire caused flap to loosen, slip out of position,

and Q. D. C. cases, there is a difference in the width—Straight Side cases require wider flaps than the Q. D. C. cases. It is not therefore advisable to interchange flaps.

The style of car construction, power, speed, road conditions, the expert or careless driver and especially the weight and its distribution, play an important part with the strains to which the tires will be subjected—consequently, a fixed rule for inflation would, in view of these things, produce different results.

Ordinarily, the tires on front wheels should be inflated between 15 to 18 pounds per inch of tire section (34x4—15x4—60 pounds or 18x4—72 pounds), and the rear tires 15 to 20 pounds per inch of tire section (34x4—20x4—80 pounds).

Resiliency of the tires is primarily governed by the construction and quality, but is largely influenced by the inflation and weight carried. Naturally a 4 inch tire inflated to 70 pounds air pressure and carrying 800 pounds weight will ride easier than the same size of tire with the same inflation, carrying 700 pounds weight. The heavier weight causes more deflection of the tires on the ground and increases the action of the side walls, thereby adding to the comfort of the ride. Increasing the deflection or flattening of tires, either by extra weight or reducing the air pressure, causes more of the vibration to be absorbed by the tires rather than by the springs of the car.

When soft, the tire runs against a wave in the tread rubber which will from excessive stretching and heating, pull away and separate

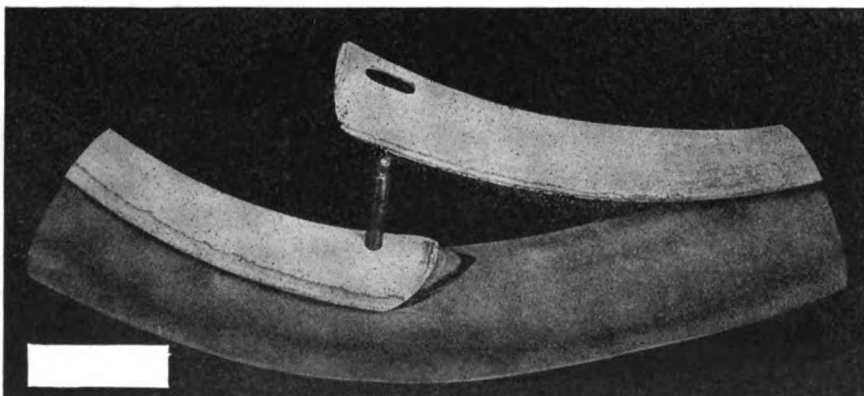

CORRECT METHOD OF APPLYING FLAP, SLOTTED END ABOVE. FLAPS SHOULD BE USED IN ALL G. D. CLINCHER AND STRAIGHT SIDE TIRES

tire are stretchable and are made approximately 1 inch less in diameter than diameter of rim, the object being to cause the tire to fit snugly to rim, after applied.

Several years ago it was a practice to use rim strips—a strip of fabric stretched tightly on rim. These strips caused the beads to fit very snugly to clinches of rim and protected the tube from rust and other damage. This was discontinued some time ago, and while it is not necessary to use flaps with clincher tires of small size, it is really the proper thing to do with this type in sizes above 4 inch, unless clips or spread-

work under beads, wrinkle and chafe tubes. The floating flap, i. e., loose from the case, proved to be more efficient in many respects. It is easier to apply tire to rim, the flap adjusts itself to suit conditions, and with reasonable precaution, it is an easy matter to apply the tire so that flap will stay in its correct position. The loose endless flap was then improved; for example, split and the ends notched in such a manner as to permit flap to be adjustable in circumference to accommodate variance in the tire.

If flaps become wet, wrinkled or otherwise damaged, it is advisable to

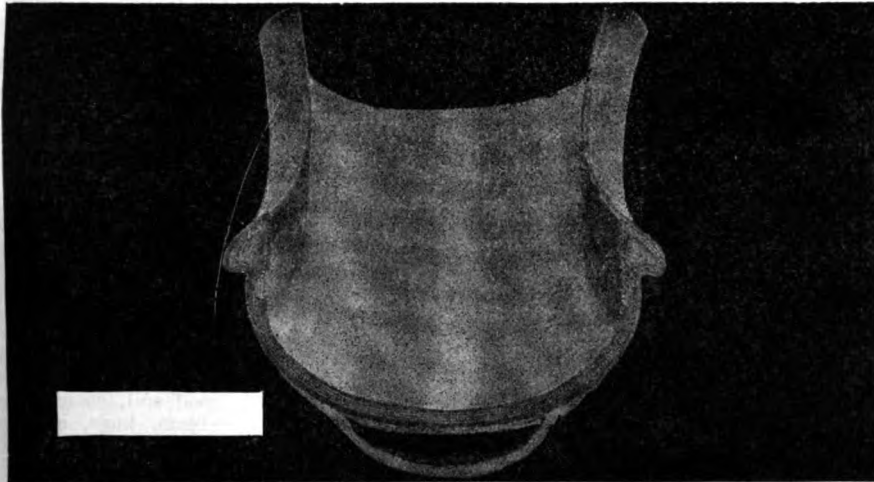

**THIS TIRE WAS RIDDEN SOFT AND IN PASSING OVER ROUGH PLACES THE RIM CAUSED BEADS TO BEND DOWN, CHAFING AND BRUISING THE FABRIC**

from carcass or body. The heat from increased action in the side walls of under inflated tires softens the rubber cement or adhesiveness between the fabric layers—devulcanization takes place, to some degree. Too much deflection of tire also means an irregular tension of one layer of fabric in relation to another—they pull apart, chafe and later, when striking a stone, rough place or rut, a blowout may occur.

There seems to be an impression of danger from blowouts due to expansion, especially during the hot weather. There is some expansion but, as a matter of fact, it is not in proportion to the increase in temperature, for example—if the temperature of the air in a tire increases from 60 to 80 degrees it does not follow that the air pressure per square inch increases from 60 to 80 pounds. It actually means an increase of 3 pounds pressure per square inch, i. e., the pressure increases from 60 to 63 pounds.

New tires stretch slightly after being in service a while and inner tubes, when heated to a certain degree, are slightly permeable to nitrogen and occasional inflation is, therefore, advisable. Deteriorating effects of stale air can be avoided by filling the tires with a fresh supply of air, at least two or three times a year.

The tires should not be inflated with the exhaust from the engine as oil and certain gases are destructive to the rubber—this does not have reference to pumps operated by power from the engine.

Don't make the mistake of guessing at inflation from appearances or by striking the tires with a hammer; use a pressure gauge, at least every week; the tires sometimes appear to round up pretty well but,

when tested with a gauge, it may be found that the pressure is entirely too low to insure the best results.

We believe the most satisfactory inflation method is to pump up the tires in accordance with formula, then, if necessary, reduce the pressure slightly until they do not cause excessive vibration to the car and traction slippage of the rear wheels. Make a record of the pounds pressure at this point and, if always maintained, the greatest efficiency from tires and car will be enjoyed.

Inflation is really of more importance than the average motorist realizes. It has a great deal to do with the life and the wear of tires and should have more attention from both owner and repairman. The motorist or repairman who gives the matter the attention it should have will find little cause to complain regarding tire mileage.

*(To be Continued)*

## The Iowa Convention

The work which is accomplished every year by the State conventions is effecting noteworthy changes in the craft everywhere. Discussions of practical problems which confront every member of the craft, enlightenment on new methods, etc. all spell progress.

Secretary Copp, of the Iowa State Association, writes us that the Ninth Annual Convention just recently held was the biggest and best "get-together" in their history.

We are of the opinion that this is quite natural, for associations organized to promote the general welfare of smiths are bound to grow, both in numbers and in enthusiasm. The spirit of co-operation and fraternity exhibited is gratifying to observe. Let us hope that this same spirit continues to manifest itself day in and day out, convention or no convention.

Enthusiasm is contagious at such a gathering—like religion on Sunday. But it should not be limited merely to the duration of such a gathering any more than religion should cease to make its influence felt during the days between Sundays.

A new and unique feature of the Iowa convention was an invitation to the ladies. The large number present greatly enhanced the pleasure of the occasion. It goes without saying that they will figure largely in the future welfare of the Association.

You wouldn't buy a new forge and then never use it, would you? Yet why some smiths pay out good money for help and never ask their advice or talk things over with them, is beyond us.

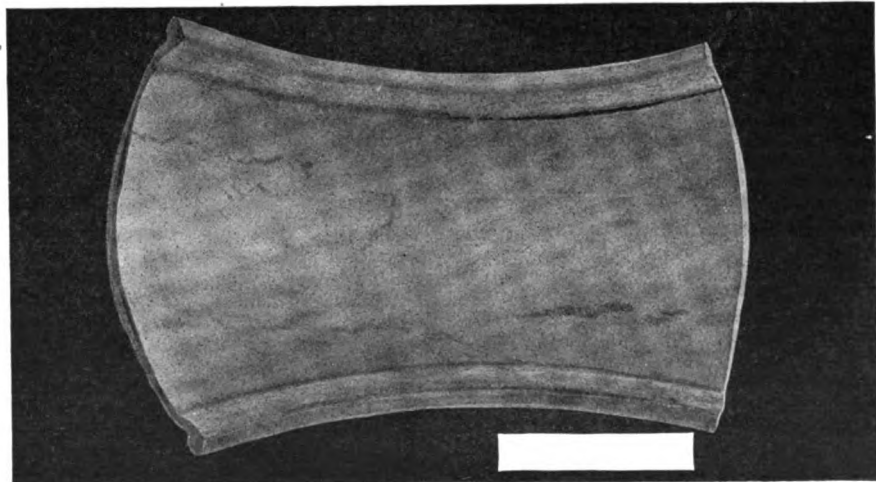

### UNDER INFLATION

Separation has resulted between plies of fabric, and chafed through until breaks have appeared inside. The hinging action in a soft tire is nearer the rim and at a sharp angle. Observe how the edges of the flap chafed the fabric.



# Benton's Recipe Book

With painting, varnishing and white-washing going on as it always does at this time of the year, a few hints on the care of brushes would be timely. The following will be found helpful:

When white-washing or kalsomining don't put your brushes into the newly slaked lime or hot kalsomine. In fact no brush should be dipped in a hot fluid or the bristles will loosen. This is due to the fact that in most brushes the bristles pass through a shank which has been kiln-dried to fit perfectly. If it shrinks its outward tension is lost and the bristles are loosened. It should therefore be kept in a cool room at all times, and if soaking, in a cool liquid.

It is advisable to clean every new brush before dipping in paint. It will do away largely with the disagreeable fault of hairs dropping out on the work. Work the bristles back and forth in the hand and remove in this way most of the loose hairs and dust. After thoroughly dry-cleaning, place in cool water for a few moments. Not long enough to cause swelling, but only until wet through. Then swing the brush and shake all the water out until shaken dry. It is then ready to dip in the paint, and although some of the hairs may then be loose, most of them will come out in the first few minutes work and can be easily picked from the surface.

A little different treatment is recommended for brushes which are to be used in varnishing and buggy painting. They should be more thoroughly dry cleaned in order that all loose hairs may be worked out. Pass the brush over a sheet of sandpaper after this cleaning. This rough surface will pull out any remaining loose hairs, and smooth down the rough ends of the chisel point. Instead of soaking in water, wash in clean turpentine and swing in the air until dry. It should never be put in water. For fine carriage work, see that the brush is thoroughly broken in on the first rough coat. There will then be little danger of any dust particles remaining when the finishing job is put on.

An important point to keep in mind in the care of any brush is to keep them at rest when laid away. That is, never stand a brush on end. Provide some means of suspending them in the "keeper".

Varnish brushes should be kept in the same varnish in which they are used, if possible, Turpentine makes them "lousy."

**A Cement for Steam and Water Pipes** is wanted by E. V. S. We think the following is as good as can be found:

10 pounds of fine yellow ochre, 4 pounds of ground litharge, 4 pounds whiting, and one-half pound hemp cut up fine. Mix

together to about the consistency of putty, using linseed oil.

For a smaller quantity, simply use these same proportions, as for instance, ounces instead of pounds.

This is very effective in pipe joints.

### Castor Oil For Brakes

It has been well said that there is one set of bearing surfaces on a car which should never be oiled—the brakes. This is not strictly true, as a squeaking brake must be oiled, but with caution. Use castor oil in moderation until the squeak is stopped.

### To Solder Aluminum

Aluminum, as compared with other metals, presents some difficulties in soldering not found in the others. This is due to the formation of an oxide on the surface of the heated metal, the oxide preventing the solder from alloying with the aluminum. This difficulty can be surmounted, however, by employing the following method:

Make a solder of 80% tin and 20% zinc; using stearic acid as a flux. Tin the surface with the above, moving the soldering copper bit backwards and forwards over the metal and flowing the solder. The film of oxide can then be cleaned off, and the coated surface can be easily soldered with the above named solder—or any tin-smiths' solder.

### When Pulling a Rusty Spike from Wood

Heat the nail head with a hot soldering iron, candle-flame or blow torch and it will come out easily. This method works equally well with rusty screws and screws that will not turn.



## Queries—Answers—Notes

**A Question on Hardening** — Will some reader please tell me how to harden and draw an expansion reamer?

J. R. THOMPSON, Massachusetts.

**Runs a Profitable Farm and Repair Business**—Myself and two sons operate a general repair shop in a busy farming section. We are generally kept pretty busy, but during our spare time manufacture a farm wagon of our own design. It was designed especially for the farmers of this section and we call it "Trent's Democrat Wagon." It is a handy, all-round rig for marketing cream cans, butter, eggs, light farm produce, etc.—in fact, like the nigger's possum, it's good anywhere. It is built on a buggy gear that it may be light enough for one horse to pull and move about easily.

Lately most of our odd spells have been taken up with auto work. We buy all of our machine repairs, and sell a lot of

stuff on special orders such as buggies, cultivators, sulkeys, hay rakes, metal wheels, etc. As repairmen, we know pretty well just what to order and keep in stock. The good old farmers of this section look to us to keep their farming tools in shape for them.

I have stood at the forge for thirty-four years, and have found that one of the biggest problems of the smith shop is collections. Some of our customers were slow to pay and others never did come across. So we are doing a cash business today—no more doing a good job today, and trying to collect tomorrow, for tomorrow never comes.

Living costs are high but our farm helps. We have besides our shop, 40 acres of our own land—good soil, clear of incumbrances, a fine team, hogs, chickens and the like.

M. C. TRENT & Sons, Kansas.

**A Business Problem**—Will you inform me what the correct sales price of the following job would be, taking into consideration shop overhead as listed?

A sled pole laid down in stock costs \$2.10; the profit desired over and above all shop expenses is 25%.

Lot, tools and stock amount to \$1800.00  
Taxes, insurance, stationery, periodicals, etc., amount to \$150.00 a year.

Salary to owner \$1,000.00 a year. (The total business for the year amounts to \$2,000.00)

Rent of place, if rented to another, would be \$20.00 a month.

A. J. NELSON, North Dakota.

**In Reply**—We would tabulate your figures as follows:

Taxes, Ins., stationery, etc. \$150.00 a year

Rent per annum, at \$20 a

month ..... 240.00 a year

Salary per annum to owner 1000.00 a year

Interest on \$1800 at 6%... 108.00 a year

(value of house, lot, tools and

stock)

Overhead per annum ... \$1498.00 a year

Income..... \$2000.00

Overhead.... 1498.00

\$ 502.00 Net profit of business

The net profits then will represent approximately 33 1-3% over operating expenses: while the latter represents 66 2-3%.

So in figuring on this job, you should add to the cost of the stock, 66 2-3% of this cost, and on top of that your 25% profit (reckoned on the cost)

Sled pole laid down in stock.... \$2.10

Overhead, add 66 2-3% of cost .... 1.40

Add profit of 25% of cost ..... .87½

Selling price ..... \$4.38

As you have not included such items as coal, heat, light, water, etc., in your overhead, we would suggest that you add a few cents to cover this. You could charge in round figures \$4.50 for the job, and be well within the limit. If you will refer to the March issue of the American Blacksmith, page 151, you will note the charges of the Kansas Association on sled work. Their price for a job similar to the job you described is \$4.65, but we presume that either the cost of stock is higher, or the average operating expenses are more. Your profit of 25% above your labor, etc., is reasonable in these days of high prices, and ought to net you good returns.

You might use these figures as a basis for figuring on your jobs in the future,



and in order to keep in line with prevailing prices, refer occasionally to the price lists frequently published in "Our Journal." S. S. New York.

**Repairing a Crack in Engine Base**—We have an auto engine with an aluminum base and it has a check in it that leaks oil badly. It would be a hard job to get it out to be welded on account of the peculiar construction. It would be quite an easy matter to put a plate over the crack if there was a cement that would not be affected by oil to put over the crack. We will greatly appreciate your help.

J. J. ROBLIN & SON, Ontario.

**In Reply**—Cut out a piece of brass to fit over the crack as shown in the accompanying engraving, beveling the edges all around. Trim a sheet of asbestos to fit this plate. Now fill up the crack with red or white lead, coat the asbestos with the lead and press smoothly over the crack. Fit the brass plate over this and mark as many small holes around its edges as can be drilled. Drill these through both plate, asbestos and engine base.

Be sure to have the beveled edges facing away from the work so that when the plate is bolted on, the edges will be drawn in and the pressure will be exerted over the crack.

S. S. New York.

**Wants a Rule for Finishing Wagon Fellos**—I have purchased 1500 wagon fellos in the rough and would like to have a rule for finishing them for the different size wheels. Just how long must they be sawed and where must they be bored for the tenon?

A. C. CANTRELL, Arkansas.

**Welding in Cast Iron Cogs**—(This query appeared in the March 1917 issue.) Would like to ask what will make the best backing in oxy-acetylene welding of cogs in cast iron wheels. The metal has such a tendency to flow between the cogs that in building up I have had some difficulty in that line."

F. G. HOSKINS, Texas.

**In Reply**—I probably understand what you mean, as I have had some trouble with my filling material spreading beyond where I wanted it to go, and would suggest that you take an old piece of carbon out of a battery, and shape it so that it will fit between the cog you want to run in and the next one. This will keep your metal from running into the space it occupies. If you will learn to lean your wheel so that the side your carbon is on is the lowest, you will get it O. K.

In welding across a hole which you are trying to save, as drilling into a weld is sometimes difficult, try plugging the hole with a carbon plug, and you will be surprised how well it will work. Carbon will stand all kinds of heat, and the metal will not adhere to it. When you are through, you can drive it out or drill it out."

J. W. POKORMY, Nebraska.

**Answers Kentucky Smith**—In looking over my Feb. issue, I find a brother smith of Kentucky, asking for a remedy for Forging or over-reaching, and hope to give one that will remove the trouble. The first idea that strikes the average shoer is to set the hind shoe well under the foot and rasp off the toe. This is just the opposite of what should be done. For you will agree that forging is caused by an increased action of the hind feet over that of the front, and as the front foot is being raised at the heel, the toe of the hind foot is thrust in under it.

Therefore, to remedy this we must do something to increase the action of the front foot and cause it to move out of the way of the hind foot also decrease action of hind foot so it will not crowd the front. Anything that you can do to bring this about will remove the trouble.

A good remedy is this: the front foot should be pared down as much as it will stand and the toe shortened. This done, make a shoe with the toe calk as near the inner web of the shoe as possible. This will set the breaking-over point back nearer the center of the foot, increasing the action in front. The front calk should be low with high heel calks.

The hind feet should be levelled and the heels rasped down as much as possible, leaving the toe long and high. The shoe should be made with the toe calk as near the outside web of the shoe as possible, thus making the breaking over point of the foot farther from the center of foot, thus retarding the action of the hind foot. The toe calk should be high with low heel calks. In nailing this shoe on, it should be set forward to make up for any shortness of the foot. The shoe should also stick out behind. The idea being to shoe with a long shoe and set the breaking over point forward, to produce a slow action of the hind foot. If this method be properly carried out, it is almost an infallible cure for over-reaching. Keep in mind anything you can do to increase the action of the front feet, and retard that of the hind feet.

HERMAN SPENCER, Kentucky.

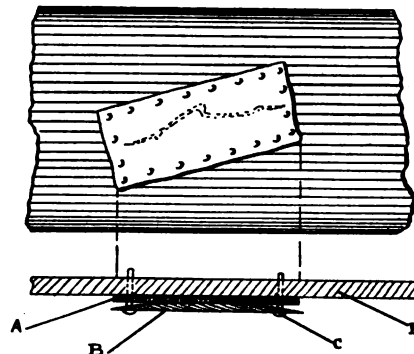

A REPAIR KINK FOR A CRACKED ENGINE BASE

**To Repair a Broken Pipe Axle**—The front axle of a light wagon is broken. It is a pipe axle, and difficult to weld. Can you tell me how to repair it?

GEO. GRIFFITHS, New York.

**In Reply**—You might try this method which is quite simple and easy. Insert a piece of tough steel bar that will fit snugly into both broken ends. This can be held firmly in place by drilling several holes through the axle and the steel bar and then riveting securely.

This job could also be done by oxy-acetylene welding. Follow out the same idea described above, and instead of holding the steel bar in place with rivets, weld along the break of the axle. This should make a good sound job. The accompanying sketch illustrates the first method using rivets.

S. S. New York.

**A Blacksmith Reporter from Georgia**—I noticed in "Our Journal" that you want every reader to be a reporter or to contribute something at least.

I have a very small business. I do general repair work and horseshoeing. My

prices are not high enough, but I have some competitors that don't seem to know or care anything about what it is worth to do their work, so I can't have my own prices as I want them. I have been in business here at Barwick, Ga., only since last August. I think I am a good horse shoer, because I can handle almost every animal that is brought to me without employing rough means. I find it does not pay to be rough. I always study to see how and what is the best way to shoe

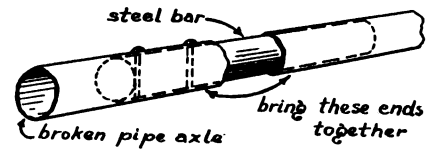

AN AXLE REPAIR FOR MR. GRIFFITHS

each and every one. I have learned partly by experience but more by reading The American Blacksmith, that it will not do to pare out the sole of a horse's foot nor to rasp away the outside wall. In this part of the country we don't need calks on shoes except in cities and so I just leave the shoe flat in most cases.

I am very much pleased with "Our Journal." I would not be without it for five dollars a year and not know where I could get another as good.

I have one competitor in this town. I have been going over to see him occasionally. He is a good fellow too, but the other day I went over and carried him a sample of some compound for welding, a recipe for which I had found in The American Blacksmith; and told him it was the best I had ever used. I saw him today and he gave me a dollar to pay for a year's subscription to The American Blacksmith journal.

Now I don't know what you think, but I think I am doing him a favor, because I know if he will study what is in this valuable journal, it will help him out of many kinks.

D. E. HONEA, Georgia.

**Answers Mr. Riddle of Utah**—Well, Mr. Riddle, you have a problem, which is a problem for all of us, and as I had nine competitors myself (one at a time) who all worked cheaper than I did, I have had some experience in that line myself.

You cannot handle all men alike, and the thing to do is to study your men, and find out their weaknesses. As you say he is not willing to raise prices, he is probably weak in the head, but that is neither here nor there. Some men can be approached by talking common sense to them and showing them figures concerning the cost of material, coal, wages, etc. Others must be jollied and patted on the back and joshed into line.

I won one of my competitors over by being chummy with him, and loaning him anything I had, and helping him in every way imaginable. When I had more to do than I could do comfortably, I carried a share of my work across to him, and let him do it and paid him my prices for it, altho he himself would do it for less for the farmer.

After a while, he decided if his work would bring better prices than he was getting at his own cut prices, it must be worth more, and so he raised his prices himself.

Another competitor persisted in cutting prices, and would not come up to standard and no amount of talk nor persuasion



would move him, so I paid no attention to him, but kept up my own, but advertised my work as "costing more but worth it," and emphasized good service.

I got three wagon poles with adjustable hounds to fit any wagon, and when a customer came in with a broken pole I loaned him one of ours to use while we repaired his, or put in a new one, so he was not delayed a bit. We got about 8 wagon wheels and loaned them to farmers who had wheels that needed rebuilding, and they could use their wagons right along, and we did the same with buggy poles, shafts and wheels.

I purchased an Oxy-acetylene plant and offered to weld castings, and that brought many of his customers to my shop. I have done everything possible to eliminate delays and now all my competitors are gone and I have the only shop in the place.

J. W. POKORNY, Nebraska.

What do we need at present? At present the nation is facing a serious situation. The blacksmiths are also facing a serious problem in high prices, and there seems to be but one solution, that of co-operation. That is the way in which the nation is meeting the present crisis. We are not living for ourselves alone, but for others as well. We need more co-operation and less cut-throat price cutting. Every member of the craft should aim to get as much for his work as his highest-priced competitor. He has no moral right to work for less, or to cut prices to get business. It will hurt him in the end just as sure as fate. He should make it a point to charge enough for his work so that he can take time to do an honest job, and give him a chance to take a vacation once in awhile. The trouble with blacksmiths is that they do not do business as business is done these days, and accordingly do not do themselves justice. They should take more time for rest and less for worry and work. 313 days from early to late with no time off is too much.

We need to work on the same principles as other good business men do. Buy for the least money possible, and sell for the most we can get. If we tried out this rule consistently, the time would come when the blacksmith would be looked up to with the same respect that owners of other businesses are. It is our own fault that we are not more prosperous as a class. We have our prices figured down to the lowest possible notch when we could get more if we but asked for it. Then on top of these low prices, some competitor begins to cut prices, and in the end both he and ourselves suffer. If one of us can't make a living at the price we are working at, neither he nor I will benefit if one of us cuts prices. The only remedy is for both of us to raise prices and maintain a decent standard.

E. E. SMITH, Kentucky.

**Editor's Note**—We are glad to see letters coming in on the question of price-cutting and how it is being met. This month brings us the two letters above and they should be of interest to every member of the craft who is concerned with better methods and greater progress. If you have any opinion to express on this vital subject, write in now. There is no time like the present, and there is no place where you can better discuss these problems, which affect blacksmiths alike in all sections, than right here in your own columns.

**Another Experience in Price-Raising.**—Please send me a copy of "Foden's Mechanical Tables." If the book is as good as The American Blacksmith, it will pay for itself a good many times over.

I see Mr. E. J. Riddle, of Utah, is up against the fellow who will not raise his prices. I had a similar experience when I was in New York. My competitor wouldn't raise his prices so I went at it alone, did my work as well as possible and finally won out—holding most of my trade for the first six months and after that time had as good a trade as I had before the raise.

Yours for better prices,

F. E. HOGOBOOM, Michigan.

**Believe Cash Business Only Way.**—Since prices began to climb over the roof of our shop, my competitor and myself have gotten together on the question of raising prices. Before, we were always pulling against each other; now we are pulling together and both get good prices for our work.

Our shops are run on a strictly cash basis, which is the only right way for the average small-town shop.

Perhaps they can give credit in the big city shops where they have a large trade, but the only way to make a decent living in a country shop is to charge cash always, and cut out credits altogether.

If your work is any good at all, the trade will come to you in the end.

G. A. RUSSELL, Ohio.



## The Automobile Repairman

### Using Common "Sense" Methods in Curing Auto Troubles—2

C. L. WHITE

Troubles We Hear

In the first installment of this series, attention was called to the necessity of actually practising this method if one would become at all proficient in using it. The senses of sight, hearing, feeling and smelling respond quickly to training and become surprisingly acute; but conscious application is necessary.

If the reader really desires to become an expert in detecting and lo-

cating automobile troubles let him ask himself these questions: "Have I thoroughly digested the article on 'Troubles We See?'" "Have I actually tried to apply its principles and practised them?"

If you have not, better stop right here, get the last issue of the American Blacksmith and go to it.

In this issue we will begin a detailed and illustrated analysis of the most important of the many troubles we hear.

Troubles we hear may be classified into the following divisions: knocks and pounds, taps, clicks and snaps, rattles and clanks, grinding and howling. We will take them up in this order, beginning with the first—

**KNOCKS AND POUNDS** which may be due to any of the following causes:

1. *Spark too far advanced when starting:* This bad practice is most common among operators or owners who are careless. It usually occurs when the engine is speeded up quickly or when engine is pulling hard at slow speed, as for example in high gear on a hill. Remedy: retard spark lever until the knock ceases. The spark lever may be kept well advanced when the gears are in high—more than half way, or when the engine is running idle. Otherwise the position of the spark lever should be determined by the speed of the engine and how hard it is pulling.

2. *Pre-ignition:* This has two distinct causes—(a) Carbon in the cylinder and (b) Hot Engine. Here the explosion takes place before the spark occurs. Carbon in the cylinder accumulates above the piston in the explosion chamber. See Figure 1 at A. It heats up readily and explodes the gas as it is being compressed. It may be caused by too much oil, an inferior grade of oil or too rich a mixture of gasoline vapor from the carburetor. Oil sometimes gets past the pistons if there happens to be too much in the base of the engine, or if the pistons or rings are badly worn. Less oil or the use of a heavier grade of oil, or some of the modern leak-proof pistons may help out.

There are a number of methods for removing the carbon. It can be scraped out by removing the cylinders or cylinder heads. Or one may employ the oxygen-burning process. This is very successful and costs but 35 to 50 cents per cylinder. Perhaps the easiest and most effective way though, is to put a tablespoonful of



kerosene into the cylinders through the priming cocks or spark-plug holes. This should be done frequently and regularly for quite a period. The best time is at night when the engine is warm. Leave it inside the cylinders until morning when the first few explosions will carry it off and along with it much of the dissolved carbon.

Adjustment of the carburetor will quickly take care of a rich mixture. Reduce the mixture until a cough is heard as the engine is speeded up.

(b) A hot engine may be due to one of the following causes: lack of circulation or poor circulation of water, caused by a loose rotor in the pump, which does not turn on its shaft; fan belt broken or loose; or an inferior grade of oil which does not properly lubricate.

3. *Connecting-Rod Bearing Loose:* (B—Fig. 1) This knock is most pronounced when the engine is under load and running at lower speeds. It sometimes disappears altogether when engine is running at high speeds. With engine running slowly, short-circuit each spark plug with a screw driver and you will easily determine which or how many connecting rods are loose. If the bearings are very much loose it will be necessary to "blue" the crank shaft with a touch of prussian blue on the finger tip and "spot in" the bearing by putting in place on the shaft. The high spots on the bearing can then be seen and scraped down until a fine bluing shows a speckled or evenly mottled appearance. The bearing can then be adjusted to fit nicely when the nuts are firmly tightened. It will be necessary to remove shims or face-off the bearing

cap if shims are not provided. If the cap has to be filed be sure to make frequent trials as the fit must not be too tight. Finally tap lightly the cap and rod with hammer to make sure that the bearing is seating firmly.

Mechanics are cautioned against tightening these bearings too tight after "scraping in". Many have made the mistake in thinking that if "a good fit was nice", then a "tight fit was better." Remember that there must be a space for the oil to make a film or otherwise the bearing will grind itself out and looseness will shortly result.

4. *Loose Crank-Shaft Main Bearing:* (C—Fig. 1) This knock is not as easy to locate as that of the connecting-rod knock. The method of fitting and adjustment is similar to that used for connecting-rods, excepting that each bearing must be adjusted separately with the other bearings loosened. Adjust these bearings so that the tightness is just barely felt.

5. *Piston Pin (wrist-pin) Loose in Piston:* (D—Fig. 1) Locate by the same method as outlined for Connecting-rod Bearings. New bushings, new pins and in some cases new pistons altogether are necessary to remedy this trouble.

6. *Piston Loose in Cylinder:* This causes what is known as "piston slap." It is indicated by the fact that the spark lever cannot be advanced to the point of greatest speed without causing a peculiar slapping noise or a metallic knock in the cylinders. The remedy is a new piston in many cases, although the following may be effective—oversize piston from another machine lapped into cylinder, or oversized piston fitted

into re-bored cylinder.

7. *Flywheel Loose:* A very elusive knock. One tries to look every other place in the car before discovering that a few bolts are loose at E—Fig. 1.

8. *Clutch Coupling or Parts Worn:* This will cause a knock that would be almost taken for a tapping, unless the parts are badly worn, when a very distinct knock will be heard. Remedy, replace worn parts. (F—Fig. 1)

9. *Transmission Bearings Worn:* If ball bearings are used, a split in one or more of the balls will cause a knocking sound. (G—Fig. 1)

10. *Universal Joints Worn:* These often cause a knocking noise when the car is under power. It takes the form of a clank and rattle as the car passes over rough pavements. Replace the parts worn. (H—Fig. 1)

11. *Tooth Gone in Bevel Drive Gears:* New gears necessary.

12. *Small piece of metal between teeth of gears:* This will cause a knocking sound in the rear axle. (I—Fig. 1)

13. *Demountable Rim Loose:* Tighten the bolts. (J—Fig. 1)

**TAPS, CLICKS OR SNAPS**

1. *Valve Stem to Push Rod Clearance Excessive.* This will cause a tapping noise. The correct clearance space at this point as shown by Fig. 2, where a workman is making an adjustment, varies on different makes of cars from .002" to 1-64". If you do not know the exact amount for the car in question, it is safe to use a business card as a thickness guage. Make sure that the lock or check nut is set tightly. Otherwise the continual hammering of the car's action will jar it loose and a "miss-

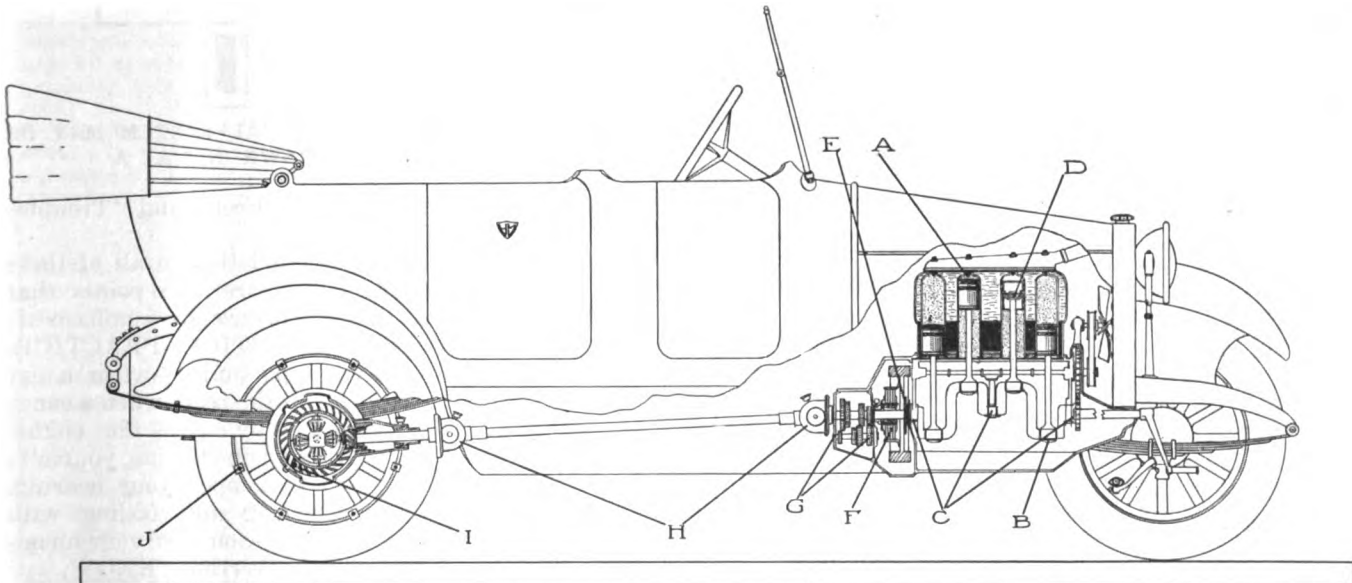

FIG. 1—CHART SHOWING LOCATION OF "TROUBLES WE HEAR"—KNOCKS AND POUNDS





ing" cylinder will result. If your car is not equipped with an adjustment screw at this point (the Ford car has not) then it is best to purchase the little pressed steel caps which are made for this purpose, and fit over the end of valve stem or plunger: or if these are not available, the valve stem itself may be "drawn out" the required length by

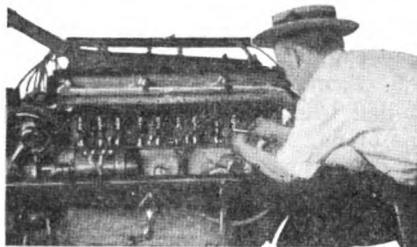

FIG. 2.—EXCESSIVE CLEARANCE FROM VALVE STEM TO PUSH ROD WILL CAUSE A TAPPING NOISE

heating the section, A of Figure 3. Draw out under the hammer and quench in water to harden end of stem.

Too great valve-stem to push-rod clearance is very frequently the cause of loss of power in an engine.

2. *Split Ball in Wheel Bearing* will cause a sharp click every time the wheel turns over. Remove the wheel, clean the bearings thoroughly with kerosene, replace worn parts, (if a number of balls have worn badly, replace all the balls) and replace the wheel. The proper adjustment of the wheel bearing is best obtained by first drawing up the nut a little too tight and then loosening the cone nut until the wheel turns freely and the valve readily turns down. The ball-bearings of the wheel should be packed with grease of about the consistency of vaseline before being replaced.

3. *Spark Plug Wire Off and Spark Jumping* causes a sharp snap.

4. *Fan Belt having Metal Connector* will also cause a clicking as this connection strikes the metal pulleys.

5. *Fan Blade Striking* some part of radiator or engine. Very often the natural spring of the blade will cause it to bend forward at high speeds and strike the radiator. Simply bend each fan blade away from radiator until they are all at a uniform and safe distance.

#### HISSES OR SQUEAKS

1. *Compression Leak* from an open priming cock, leaky spark plug or blown-out gasket.

2. *Suction Leak* in intake manifold pipe between the carburetor and the engine. This will sometimes cause a squeak which is almost a

whistle. One would almost think that the engine was in bad need of oil.

3. *Steam from Radiator Overflow* pipe causes a hissing sound. If in the winter it is often caused by no circulation of water due to a frozen bottom of the radiator. Cover entire radiator carefully and often its own heat will thaw the ice and normal circulation will be resumed. If the water is too low in radiator, boiling will result.

4. *Springs Dry*. This causes a squeak. The most satisfactory way to lubricate the springs is to remove them entirely from the car and take them apart. Clean the leaves thoroughly and lubricate with a very thin coat of grease with graphite. The springs should be entirely lubricated in this manner at least once each year. For quick lubrication the spring leaves may be separated with a clamp device (See Fig. 4) made for the purpose and grease with graphite applied between with a thin stick.

5. *Tire Going Flat* will cause a hiss.

6. *Oil needed* at some part of the car will of course cause a real old-fashioned squeak that we all easily recognize.

#### RATTLES AND CLANKS

1. *Brake Rod Ends Loose*—These parts are often neglected as far as lubrication is concerned.

2. *Universal Joints worn* will cause a clank when car passes over deep car tracks or ruts.

3. *Brake Bands loose* or release springs missing will also cause rattling over rough pavements.

4. *Steering Spindles and Connections worn* will naturally allow clanking or rattling over rough pavement.

#### GRINDING OR HOWLING.

1. Gears incorrectly adjusted or badly worn will cause this kind of noise. If it becomes necessary to replace a worn bevel-drive gear it is always advisable to also put in a new mate. No specific rules can be given for adjusting the bevel drive gears. Speaking generally, the older the gears, the more backlash (looseness) should be allowed. The "try-out" method is the best. To enable one to judge of the location and intensity of grinding noises at the rear of the car, it is advisable to lie on the running board and hold the head back of the rear fender near the rear wheel.

2. *Bearings Badly Worn*. Ball or roller bearings when worn badly will cause grinding.

We could go on enumerating many other troubles we hear, but in the foregoing only the most common have been given, excepting those that are so obvious that anyone would know what was wrong and where to locate it. The remedies proposed are not claimed to be the only and best by any means. The author has found them excellent in his experience of many years as an automobile engineer, and he is only to glad to welcome suggestions from readers as to their methods wherein they differ.

In the next and last installment of this series, we will outline

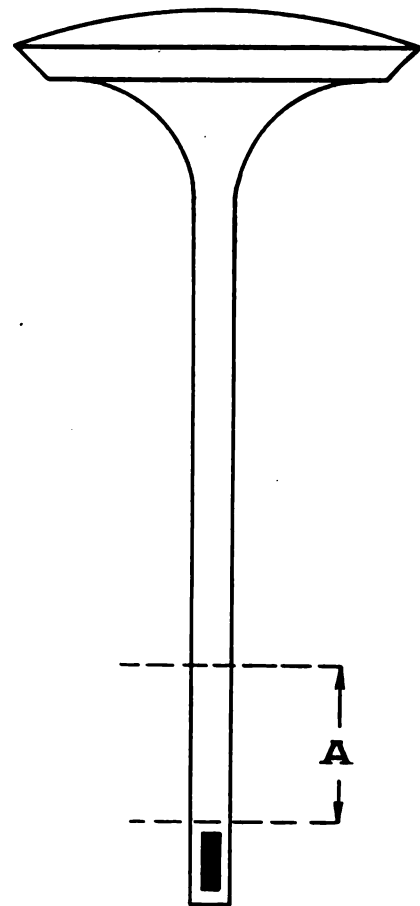

FIG. 3.—THE VALVE STEM MAY BE DRAWN OUT AT A

"Troubles We Feel", and "Troubles We Smell."

Bear in mind that in all of these articles there are two points that cannot be too strongly emphasized: practice, PRACTICE, PRACTICE, at every opportunity—when a car passes you on the road, when a car is standing nearby with the engine running, or when driving yourself; and learn to temper your hearing, seeing, smelling and feeling with common sense—don't let your imagination work overtime, KNOW.

(To be Continued)



# TIMELY TALKS WITH OUR SUBSCRIBERS

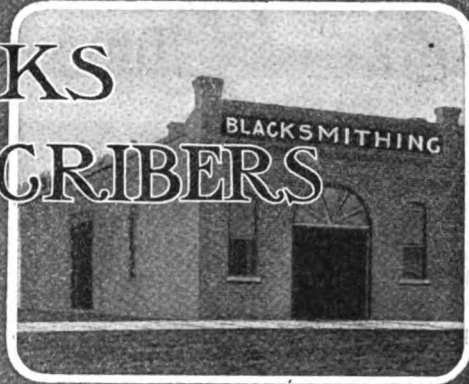

The American Blacksmith is published monthly at The New Sidway Building, Buffalo, N. Y., U. S. A., by The American Blacksmith Company. Incorporated under New York State Laws. Entered, February 12, 1902, as second-class mail matter at Buffalo, N. Y., Act of Congress, March 3, 1879.

William F. Wendt, President  
 Associates: James Cran - Bert Hillyer - A. C. Gough - Dr. Jack Seiter  
 Albert W. Bayard, Secretary  
 Walter O. Bernhardt, Editor

Subscription Price: \$1.00 per year in advance, prepaid to any postoffice in United States or Mexico. To Canada, \$1.25; other countries, 6 shillings. Reduced rates to clubs of five or more on application. See "Honor Roll" page for money-saving, long-time rates. Cable address, "Blacksmith," Buffalo. Lieber's Code used.

Subscribers should notify us promptly of non-receipt of paper or change of address. In the latter case it is necessary that you give us both the old and the new address.

## LET'S GET TOGETHER

On every hand we see the spirit of co-operation bringing success and progress to individuals, organizations and communities. It's the spirit of get-together—you and I. Hundreds of blacksmiths in all parts of the country, who were perhaps at each others throats a few months ago, have now organized for mutual help and benefits; they have joined hands in raising prices and in maintaining a stable price once fixed; in creating higher standards of workmanship. And so on in nearly every industry we find co-operation, helping, lifting, inspiring.

How about you, Reader? Are you co-operating? Are you working hand-in-hand with brother craftsmen, keeping up with the successful spirit of the times—benefiting by their suggestions, benefiting them by yours; or are you still following the hard way of single-handed, up-hill effort?

'Bout time you changed, isn't it? Perhaps you have just been too busy to give the matter even a thought. But just stop a moment to think that this is YOUR magazine. That others have written literally volumes for you—telling of their experiences, methods, helpful shop kinks, etc., and that you have never written anything for them.

Now isn't it about time you got busy and contributed something yourself? Come on, co-operate! Get out your old slate pencil today and let us have a few lines from you. You may not be gifted with fluent speech or ready wit, but we'll guarantee that you know a thing or two about practical shoeing, or welding, or forging, or equipment, or something that is worth a lot to brother smiths. So let's get together—let us hear from you, NOW!

### Subscription Agents

When a stranger solicits your subscription to THE AMERICAN BLACKSMITH or any other publication, insist upon him showing you absolute proof that he is an agent in good standing and is employed by the publication which he represents. Don't under any circumstances, give the man your money if you are not sure that he really works for the paper he says he does. No matter what the man offers you—no matter what price he makes—no matter what premium he promises to send—Don't Give Him Your Money If You Are Not Sure.

## CONTENTS, JUNE, 1917

The Smith's Biggest Helper— Frontispiece .....	210
Put the Power Hammer to Work...	211
Watch Your Contracts.....	213
Blacksmith Honored by Kings.....	214
The Horseshoer.....	215
A Bit o' History.....	215
The Oxy-Acetylene Plant—4.....	216
The Care of Tires—3.....	219
The Smith in the Daily News.....	221
The Blacksmith's Heaven—Poem...	222
Heats, Sparks, Welds.....	222
Our Honor Roll—Kansas Still in the Lead .....	223
The Machine and Tool Smith.....	224
Fundamentals of Lathe Practice..	224
A Spring Circular.....	225
What's the Circumference?.....	229
Another Handy Chart.....	229
Benton's Recipe Book.....	230
Brass Polishing Compound.....	230
Metal Dough for Stopping Leaks.	230
To Prevent Hot Lead from Stick ing .....	230
To Cool Steel without Hardening..	230
Recipe for an Iron Cement.....	230
Queries, Answers, Notes.....	230
What's the Best Way to Make a Bar Shoe?.....	230
Cleaning Scale Deposits in Ra- diator .....	230
For Treatment of "Seedy-toe"...	230
How to Make Homemade Bat- teries .....	231
A Criticism .....	231
Is Tungsten Steel High-speed Steel? .....	231
Browning Gun Barrels.....	231
The Automobile Repairman.....	232
Using Common "Sense" Methods in Curing Auto Troubles—3.....	232
Gas Engine Operation Made Simple	233

## AN OLD FRIEND ON THE JOB AGAIN

This month we welcome Brother Bishop back to our columns. He's here with the feature article—and it's a winner! He tells us about power hammers, everything from A to Z, and what B. B. don't know about power hammers would just about cover the back of a Pink Buffalo Stamp.

You'll enjoy reading his stuff, both this article and the installments which are to follow, whether you are one of those fortunate individuals who already possess a power hammer or one who does not even own one yet. The series will be thoroughly practical from start to finish, instructive, and imbibed with a touch of humor such as only Mr. Bishop knows how to use.

By the way, this morning's mail just brought his second installment and it's a hummer! Starts off something like this: "We anvil wallopers don't beat the devil's tatoo on the anvil every day because it's funny, nor altogether because we are fond of music. We do it because old H. C. O. Living, with spurs on both heels and a rawhide whip in his hand, rides us like a busted jockey rides a wind-broken skate in the last race at the County Fair. That jockey needs the money—and so do we. And if we can get the money—more and easier....."—but 'nough said, just wait until it appears in next month's issue!

## A LETTER FROM TEXAS

"I find one recipe in your last number worth five dollars to me. This is only one of many that I find of value to our craft in each and every issue. I think your paper is getting better all the time, especially the automobile pages and Benton's recipes. I have been taking it for about nine years and consider my money in it well invested."

This is just an example, picked up at random from among dozens of equally sincere and complimentary letters—an example telling us how one of our good friends feels about his craft paper.

How about you, Reader? You've surely got some opinion, either one way or another. If it's a boost, let's have it—to help along the good work; if a knock, don't hesitate to write at once and knock good and hard. Constructive criticism, sincere and well meant, is invaluable toward the progress of any enterprise and no less is it needed in your craft journal.

Again we repeat, "Let's get together."

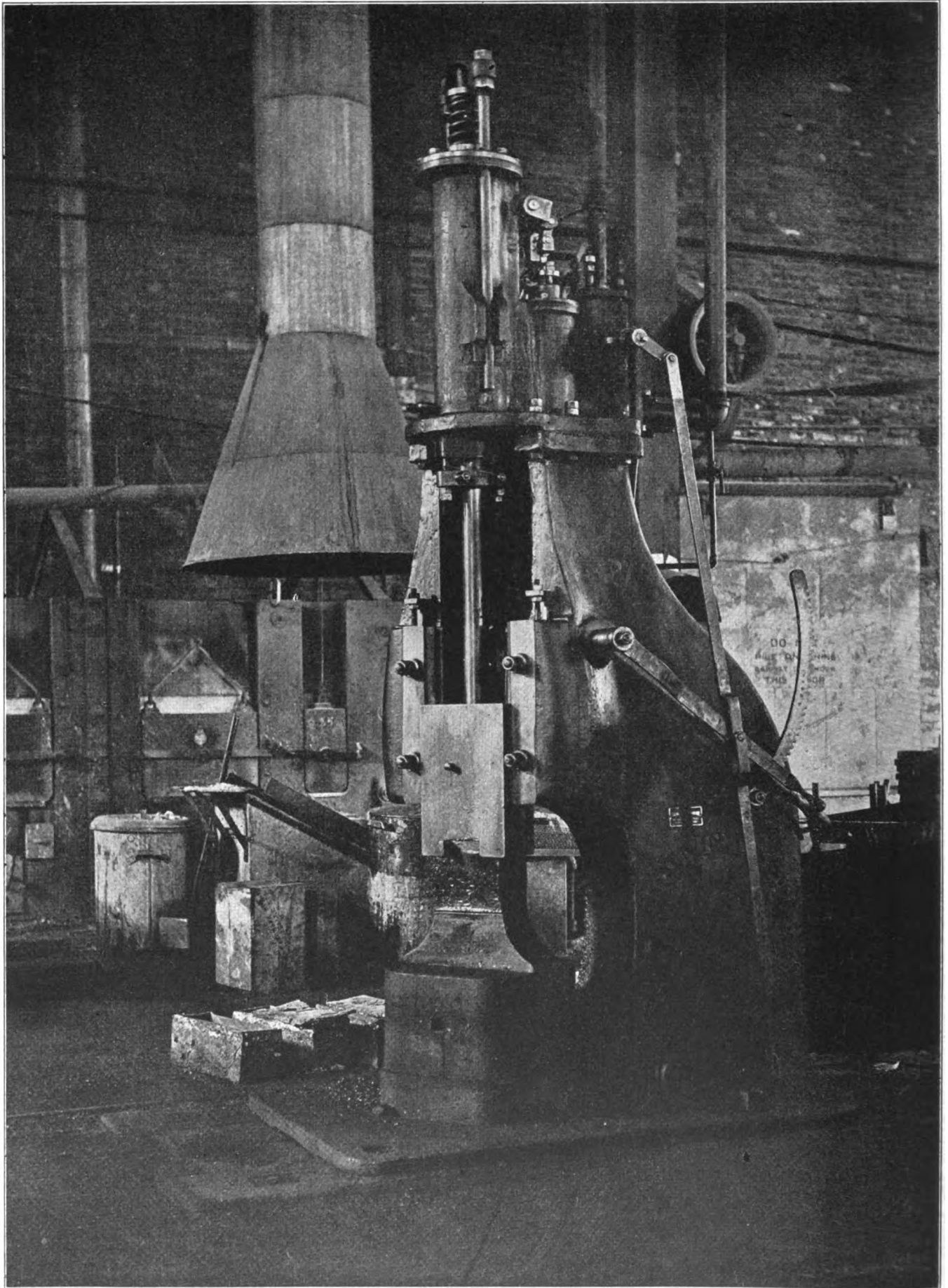

THE SMITH'S BIGGEST HELPER—HIS POWER HAMMER



# Put the Power Hammer to Work

BY WILL BISHOP

The first thing I want to say, brother iron-bruizers, is that Bishop is my name—not my occupation. I'm an anvil slugger just like the rest of you. For twenty years I've made so much noise lambasting an anvil that if old Cyrus P. Opportunity ever came along and knocked on my door to offer me the job of being President, I did not hear him. And during those years I've listened to many a hard luck story from a customer when I had expected a payment on his bill; worn shirts with bellies burned out by sparks; been kicked by horses and knocked by competitors—just like the rest of you. Like the rest of you, also, I've grabbed Old Man Life by the neck and made him come through with a fair living and a fair share of enjoyment, just the same.

Now the above paragraph may have aroused in you a suspicion that I have taken advantage of the good-natured editor of Our Journal, intending thus to slip a history of my life over on you. Nothing doing. I haven't got the nerve, and besides, I've something up my sleeve that is far more interesting and profitable.

I just made the statement that I am lacking in nerve; but some of you will no doubt think I have my nerve with me when you read the following sentence: the object of this article is to put you wise to a loafer in your shop! Yes, a real loafer that kills time for which you pay him, though he is the best man you have in your shop if you make him work. Believing in speaking right out in meeting, I'll tell you his name: It is Power Hammer. He is the lad who loafs when he should be at work; and I aim to tell you in a series of articles, of which this is the first, how to rig him out and put him to work, so that he will earn his keep and a surplus for your pocket.

In writing these articles on the power-hammer, and power hammer tools and their uses, I am assuming that at least fifty per cent of blacksmiths in the ordinary custom shops don't get the work out of their hammers that they should. I think that I am a fair representative of the

average smith, as to experience and competence, and I confess, very frankly, that in spite of my long and wide experience at the trade in various parts of the country, it was only recently that my eyes were fully opened to the time-saving, labor and sweat-saving, neat-working and profit-making ability of the power hammer. At another time, I will tell you how I came to get wise to the possibilities of the power-hammer as a worker for the general smith.

Before I go any further, I want to say that tools—tools, many and various tools—are just as necessary to the successful working of a hammer as they are to successful hand work on the anvil. And if in this series of articles I can explain how to make and use hammer-tools, such as you use every day on the anvil, with the only difference that they are designed for the purpose of letting Old Power-Hammer do the

easier it is to operate on forging. The small, quick-stroke, rapid-fire hammer is not as good as a heavy hammer; still it can be made to do an enormous amount of work. The first thing to do with any hammer is to see that the dies are right. Have the bottom and top dies exactly the same size; see that the faces are perfectly level, and adjust them in the hammer so that when the top die is down and resting on the bottom one they are in perfect alignment all around. Use dies of the greatest size that will pass between the guides that enclose the hammer-ram. This gives greater die-face area, and that is a great factor in forging. I have known smiths to use a hammer year in and year out, never changing dies. In fact, they did not use the hammer at all, to speak of, only in sharpening time, and just left the fuller-shaped sharpening top die in the hammer all the time. The sharpening die is no good

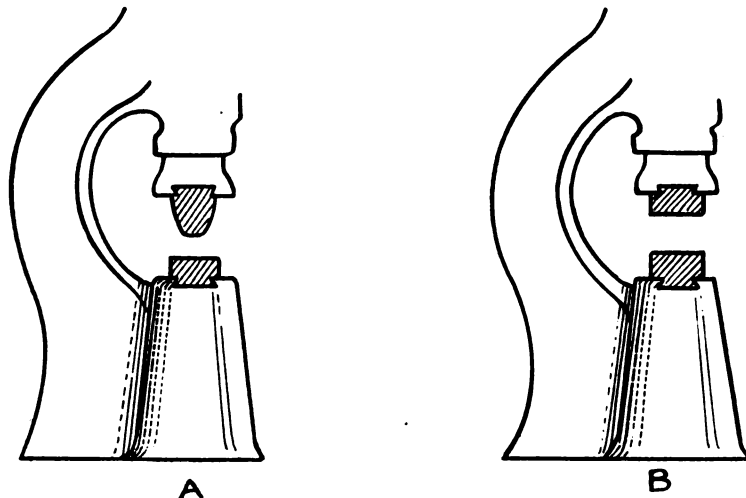

FIG. 1, A—HAMMER FITTED WITH SHARPENING DIES. THIS STYLE OF TOP DIE IS ALMOST USELESS FOR FORGING.  
B—HAMMER FITTED WITH CORRECT FORGING DIES

strong-arm work, I will feel that I have done something of benefit to the craft to which I belong.

Now a word about hammers. It don't make any difference what kind of a hammer you have; it can be either upright or helve model, and the tools I am going to tell you about will apply equally as well. However, the larger and heavier your hammer the better work it will do, and the

for forging, and if you haven't a top die to match the bottom one, get one, or make it. Better still, get a new pair; larger if your hammer will carry them.

In the drawing at Fig 1-A, is shown a hammer fitted with sharpening die, which is wrong for forging. See the drawing at Fig. 1-B for hammer properly fitted with dies for forging.



This now brings us down to the question of hammer tools and how to make them. In this first article I will deal with the simpler forms of tools, those used in most every job that enters the day's work; such as hot-cutters, cold-cutters, fullers, flatters, taper-tools, forging-blocks and so forth. In each following article I'll take up other tools and special pieces of forging until I've run out of soap, or until the readers of Our

handle of this tool, hammer thin, say  $\frac{1}{8}$  x 1 inch, a space of four or five inches just back of the cutting head. This makes the handle flexible and prevents sore hands resulting from jar, in case you don't hold tool perfectly level with the dies. Any tool that is made to hold on top of the work should have this shock-absorbing feature. You will note this feature in all drawings of this class of tool.

circle. It is well to have several of these cutters, each bent to a different radius. See Fig. 3 at A for end-view of this tool.

Still another fuller that is very handy for fullering and grooving of many kinds is the round fuller seen in Fig. 4. Simply take a piece to tool-steel and make same as sketch. It is well to have several sizes of this tool, ranging from  $\frac{3}{4}$  inch to  $1\frac{1}{2}$  inches in diameter.

The flatter, as you all know, is one of the most important tools we iron punishers use. And we flatter ourselves that we can flatter out a flatter surface with a flatter than is flattered by any other craft of flatters. But just give Power Hammer a flatter like the flatter in Fig. 5, and he will out-flat any flatter that ever flatted a flat surface with a flatter, and flat it flatter. Excuse me! This flatter, as you will see in the sketch, is a half-circle on top. It is made thus to allow it, when placed on work of an uneven, or tapering surface, to afford a solid bearing for the top die of the hammer, and at the same time the face of the flatter inclines to the taper of the work. This is an indispensable tool, and is not hard to make. To make, take about six inches of  $1\frac{1}{2}$ " square tool steel, fuller in all-round two inches from one end and draw out short end under hammer to  $\frac{3}{4}$  inch; then weld on enough  $\frac{3}{4}$  round soft steel to make a handle two feet long. Now then, get a piece of 1" x 4" soft steel and cut off a piece four inches long. This makes it 1x4x4 inches, and when you have made it good and hot, lay it on the bottom die of the hammer and take a piece of  $\frac{3}{4}$ " round and lay across the center of your heat, lengthwise with the dies, and drive it down level into the heat. Then take out the  $\frac{3}{4}$ " and lay in same place a piece of 1-inch round and

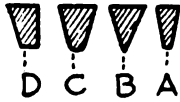

FIG.2-HOT CUTTER

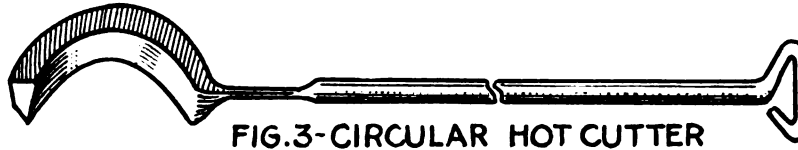

FIG.3-CIRCULAR HOT CUTTER

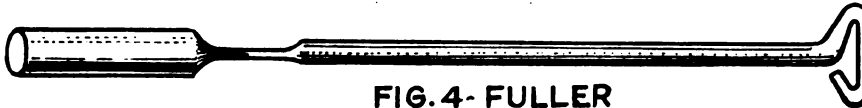

FIG.4-FULLER



FIG.5-FLATTER

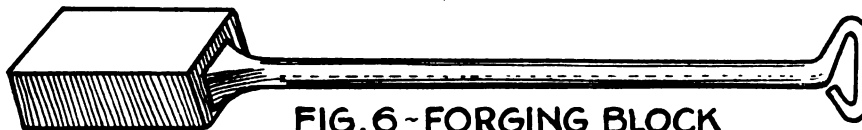

FIG.6-FORGING BLOCK

Journal howl for the editor to choke me off.

A tool we use every day is the hot-cutter. It is made for the hammer like the sketch in Fig. 2. Just take a piece of one inch tool-steel and draw out a handle about two feet long. Make the handle about a half inch in diameter. Then cut about four inches of stock off for your cutting head, place under the hammer and work it square. When you have it about  $\frac{3}{4}$  inch square, take a piece of  $\frac{5}{8}$ " round iron for a fuller, lay your work lengthwise on the die and use the  $\frac{5}{8}$ " round to fuller it down to an edge, leaving the cutter about  $\frac{3}{4}$  of an inch thick on the back. Do not make the cutter sharp on the cutting-edge; leave it  $\frac{1}{8}$  of an inch thick, and finish perfectly square. Temper same as hand hot-cutter. See Fig. 2-A for end view of cutter. Caution: in drawing out the

A cold-cutter is made same as hot-cutter, only the back should be a bit thicker, and, of course, it is finished with sharp cutting-edge. Grind and temper same as anvil cold-cutter. See Fig. 2 at B for end-view of cold-cutter. Top fullers are also made in same style as the above cutters, with the exception of having round edges. See Fig. 2 at C and D for end-views of fullers of this style. The section at D shows side-fuller. This fuller has bevel all on one side, and is designed for fullering-in where a straight off-set is desired.

It is often necessary to trim ends of forgings, straps, bars and so forth with a round finish. For this purpose a quick, neat job is made with the circular hot-cutter, which is shown in Fig. 3. This cutter is made same as the one in Fig 2, only it is beveled all on one side, and bent with the bevel on the outside of the

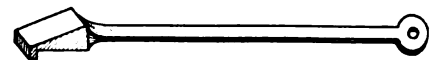

FIG. 7.—TAPER-TOOL

drive it down to same depth; then put in a piece of  $1\frac{1}{4}$  inch round and do likewise. Now heat up again and this time use a piece of 2-inch round to finish, being sure not to drive it any deeper into the work than was driven the piece of  $\frac{3}{4}$ " round at first. Now cool her off and you have a tool to finish your flatter in. Heat your flatter-head, place the swage you just made on the bottom die of the hammer, lay the flatter-head



in the groove of the swage lengthwise — don't lay flatter-head flat on a square side, lay it in tool cornerwise and hammer down until the swage groove is filled up. When you have finished on anvil, you have a hammer flatter.

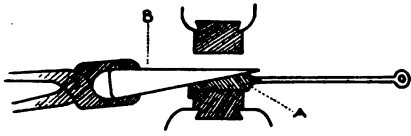

FIG. 8.—DRAWING OUT WEDGE ON TAPER-TOOL

In many cases of forging, such, for instance, as would require the use of a set-hammer when doing hand forging, it is necessary to have a hammer tool to answer this purpose. For this the proper caper is a forging-block. This tool is made as in Fig. 6. Simply take, for example, a piece of 1 1/4" square steel about six inches long, fuller it about 3/8" deep on four sides, two inches from

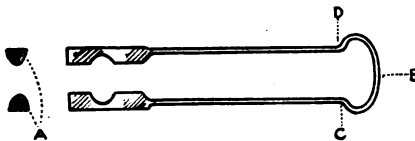

FIG. 9.—BOTTOM AND TOP FULLER

the end, and draw out short end to 5/8 or 3/4 of an inch and weld on handle, and the forging-block is complete. This tool can be made either square or flat and is very handy, in many different sizes and shapes.

In the sketch in Fig. 7 is shown the taper-tool. It is not necessary to go into details of the method of making this tool, so I will merely state that any old scrap of soft steel—a piece of a heavy wagon axle for

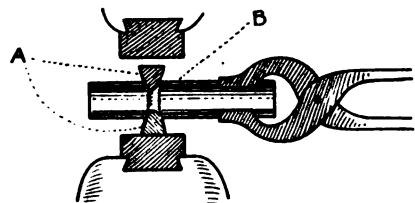

FIG. 10.—FULLERING A PIECE OF ROUND IRON WITH BOTTOM AND TOP FULLER

instance, will do nicely for making a large taper-tool where a steep taper is required, and a piece of 1"x4" will do for a tool of slight taper. A half dozen of these tools, all of different tapers, are required to complete your set. This tool is exceptionally adapted to the welding on of the point when pointing a plow

share. See Fig. 8 for illustration of drawing out common splitting wedge on taper-tool. Taper-tool at A; wedge at B.

The next, and last tool in this article is the bottom-and-top fuller. The sketch in Fig. 9 will give you an idea what this tool is like. In drawing out handle, make thin in center (at B) from C to D. This should be about 1/4 x 1 1/2 inches and the rest of handle about 3/8 x 1 inch; with fuller heads made the size of fuller required. See section A for end-view. Several sizes of this tool are needed for a complete set.

At Fig. 10 is an illustration of the method of using the above fuller. Section A shows end-view of fuller; and Section B a piece of round iron being fullered all-round.

In my next article I will take up swages and allied tools. When we have completed a set of tools for the hammer, I will take up a few special cases of forging and endeavor to explain their practical application. Of course, it is understood that those who have had little experience in hammer forging will need to use perseverance and a little of that stuff that all blacksmiths have under their hats, in order to get the hang of the work. But stick to 'er, boys; she's a winner!

(To be continued.)

### Watch Your Contracts or Order Blanks for These Clauses

Almost every written or printed paper in the nature of a business contract, which comes to me now-a-days, has a clause in it which is intended by the seller to remove his responsibility for any verbal statements which his salesman or agent may have made in making the sale. The substance of the clause is: "This paper is the entire contract, and the seller is not responsible for verbal statements made by salesmen."

So general is this practice becoming that it behooves business men more than ever to-day to see that they do not make purchases or contracts on verbal statements which are not incorporated in the written contract or order blank. If they do, and the paper contains the provision I have referred to, the buyer will often find the transaction wholly different from what he expected it to be.

A case has just been decided by a Southern Appeal Court which shows

very clearly what I mean. A salesman went to a blacksmith who was in the market for a particular kind of a machine, and he represented to him that his machine would do a certain kind of work. He was not general in his remarks; he was specific, and he told in detail just what kind of work the machine would do.

The blacksmith believed him and placed an order, not thinking it worth while to examine the contract, to see if it contained anything which disagreed with the salesman's verbal statements. As a matter of fact, the order blank contained only the following about the work which the machine would do:

It is warranted to be made of good material and durable with good care, and to be capable of doing more and better work than any other machine made of equal size and proportion working under the same conditions on the same job, if properly operated by competent persons, with sufficient steam or horse power, and the printed rules and directions of the manufacturer intelligently followed. The condition of the foregoing warranty is that if, after a trial of ten days by the purchasers operating in the manner specified, said machinery shall fail to fulfill the warranty, written notice thereof shall at once be given.

Nothing whatever here about the specific work which the machine would do.

Later a dispute arose over the work of the machine, the buyer claiming that it would not do what the salesman had said it would do.

The seller brought suit, and the case was tried, the buyer relying upon the verbal representations of the salesman. He lost at every point. The court said in substance: There were two warranties here. The salesman's verbal representations as to what the machine would do constituted one, and the written language (reproduced above) constituted another. But the written warranty entirely superseded the verbal one, and the buyer had no right to rely upon the verbal warranty at all.

The buyer here also fell down by not notifying the seller that the machine was not satisfactory, but even if he had done that, the decision, I take it, would have been the same, that is: that the statements of the salesman were out of the case, because the written contract contained something inconsistent with them.

How could this buyer have saved himself? By saying to the salesman: "Here, you put what you say into the written contract."



Of course, sometimes fraud is behind these contract provisions as to the seller not being responsible for verbal understandings. Sometimes a sale will be deliberately made by false representations, the responsibility for which the seller seeks to disavow by some such clause as the above. He will not be permitted to do so, if there is fraud.

Such a case was recently decided. The seller told a lot of lies about his goods and then made his buyer sign a written contract containing the following:—

This is the only contract made by us, and it is not to be changed or varied by any promises or representations by ourselves or other people.

The buyer soon found he had been done, but when he started to show up the seller's false representations, the latter pointed to the above clause in the contract and smiled triumphantly. The court, however, soon changed the triumph into defeat. The ruling was as follows:

If the seller made statements which he knew or should have known were false and thus induced the buyer to purchase, relying on such statements, the effect of such fraud cannot be overcome merely by a contract expressly omitting warranties. Because the fraud was so successful as to induce the buyer to take a contract without a warranty is all the more reason that there should be liability on the fraud.

So that where the verbal statements of a seller, or his salesman, are fraudulent, the buyer can always take advantage of them, no matter what the written contract says about it. But where they are not deliberately fraudulent, or where they are only inconsistent with the written contract, he cannot. It is very hard to prove deliberate fraud, incidentally.

(Copyright by Elton J. Buckley.)

## Blacksmith Honored by Kings

His Skill Attracts World-wide Attention.

To say that luck from horseshoes is a mere myth, is to contradict a proven truth—at any rate in this particular case. For in a small Pennsylvania town there lives an humble son of Vulcan who, through no privilege of birth or high attainment, has won the recognition and good wishes of many of the greatest living members of the Hall of Fame, and all on account of a horseshoe.

It was the happy lot of Charles Gorsuch to conceive the idea of hammering out miniature horse-

shoes on his anvil and to present these tiny emblems of good luck to the world's notables. The courteous acknowledgments of his little gifts come from kings, presidents, emperors, queens, senators, explorers, governors and hundreds of other famous people.

Shoe is a Fine Piece of Work.

The magnet which has drawn all these attentions from such a distinguished body is a little hand-forged horseshoe—perfect in every detail and slightly smaller in size than a dime. Many who have examined it

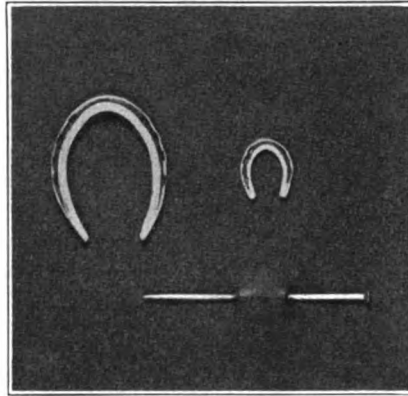

LIFE SIZE REPRODUCTION OF THE LITTLE SOUVENIR SHOES HAMMERED OUT BY MR. GORSUCH

closely have pronounced it a remarkably fine and delicate piece of workmanship. The writer was presented with one of the smallest specimens of the maker's handicraft, an exact and faithful replica of the shoe which is worn by every horse, and no bigger 'round than a pencil.

When it is considered that these diminutive shoes are hammered out on an ordinary blacksmith's anvil with a large hammer and that no special tools, with the exception of a small punch, are used, the superior skill that goes into their making is at once apparent.

Letters from All Parts of the World

It is said that Mr. Gorsuch possesses the largest and most valuable private collection of autograph letters and photos in the United States. Among them are letters from nearly every crowned head of Europe; messages of appreciation couched in all the formality and dignity maintained in Court circles.

Then, from famous personages closer to the general public, come letters with a more personal touch.

Mark Twain, for instance, after receiving a tiny horseshoe shortly before his death, had it made into a scarf pin and addressed a letter to

Mr. Gorsuch, written in his own hand and containing these remarks: "Now that the horseshoe is mounted as a scarf pin, it has become useful as well as beneficial."

Another message, and one of the most recent, is from Hon. Thomas R. Dewar, a prominent member of the British Parliament. It is here reproduced:

Dewar House,  
Haymarket S. W.,  
5th February, 1917.

Dear Mr. Gorsuch,

It is indeed a long time since you first introduced yourself by sending me that delightful little souvenir, the hand forged horse shoe, but I had no idea it was so long as twelve years, for it does not seem nearly so much as that. I have preserved it since you were good enough to send it to me, and although I am by no means superstitious, as I have come across nothing that might be called bad luck, we must put it down, in a way, to the little horse shoe from the U. S. A.

Many thanks for remembering me again and sending me another, also for the good wishes which accompany it. I must heartily reciprocate all your good wishes for 1917 and as history is being made so rapidly now-a-days, the times are different even to when you wrote me on January 15. The last few days have certainly drawn Great Britain and your great Republic nearer and closer together, and what may happen within the next few days there is no telling.

However, whatever these events may be, we all hope that the present year will see a decisive and triumphant victory for the Allies in the cause of Humanity and Civilization.

Believe me,  
Yours very truly,  
Thomas R. Dewar.

Charles Gorsuch, Esq.,  
U. S. A.

His collection of letters would easily fill several volumes. They are written in nearly every civilized language and their writers, in many cases, seem to attribute almost supernatural powers to the little horseshoes.

The late Admiral George Dewey claimed that he had had good luck from the moment he received his shoe. Lieutenant Peary carried one with him as a mascot on his last dash for the North Pole.

The list of notables alone, who have shown their appreciation of the little gift, would occupy pages. It includes Col. Roosevelt, former President Taft, Hon. Wm. Jennings Bryan, Arthur Conan Doyle, Buffalo Bill, Hon. W. W. Asquith, Winston Churchill, Carnegie and Frick, Admiral Nogi, and several hundreds of others—the complete body of recipients numbering over a thousand.

His Ancestors Were Blacksmiths

Mr. Gorsuch's remarkable skill, which has won for him the title:



"Master of the Forge," was inherited from a long line of successful blacksmiths and prominent iron workers. The first of his blacksmith forefathers to take up his abode in this country landed at Baltimore in the year 1662. The male descendants from that time down have been well skilled in the art of forging metals, which probably accounts for the special adeptness of Charles Gorsuch.

Mr. Gorsuch is engaged actively in ordinary blacksmith work day after day in his shop at Martinsburg. He uses his skill in fashioning a "life-size" shoe for a horse just the same as if he was forging one of his tiny gift shoes. He frequently will be seen shoeing a horse of some farmer at that section, and after his customer leaves the shop will go to his anvil and with the same hammer used in hammering out a shoe for the horse will forge another of the little emblems of good luck, which have delighted so many of his fellows in all parts of the world.

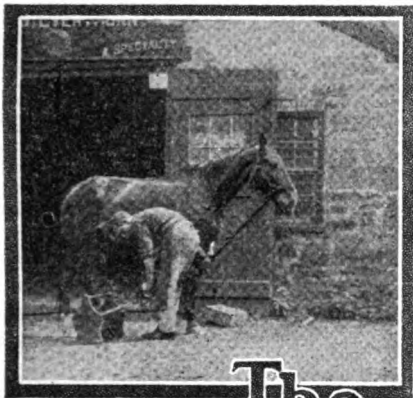

## The Horseshoer

### A Bit o' History

E. H. MALOON

April 12, 1917 marked the completion of my fifty years of service at the forge, and a strenuous half century it has been. Many times I have been on the point of writing something about my life for "Our Journal," and particularly so some weeks back when there seemed to be an epidemic of "life histories" loose among blacksmiths all the way from Maine to California. I could relate many an experience myself which, no doubt, brother craftsmen would find interesting reading; and my long experience has given me a hoard of valuable pointers and kinks in shoeing well worth describing.

Perhaps, someday, I shall tell

more fully of my life as a follower of the craft of Vulcan; at any rate I



MR. CHARLES GORSUCH, "MASTER OF THE FORGE"

shall from time to time outline methods of shoeing which I have found to be of great value.

At the present I am going to limit myself to telling about the hardest three months' work I was ever up against, and about a little shoeing job that was quite out of the ordinary and, because of its success, points out a moral worth heeding.

My life from eleven to sixteen years of age was spent mostly in a New England cotton mill making stockings; a job that in those days was almost akin to slavery. Little did I dream then that I would be forging out "iron stockings" in days to come. But when I had reached the age of sixteen, my father took me to learn the blacksmithing trade, and for three years following I was busy mastering the fundamentals of horseshoeing and forging.

The winter of 1871 found me located in Meridith, a small town in central New Hampshire. I was then nineteen years old, five feet-eleven inches tall and weighed less than 150 pounds. There were three shops in town, one of which was occupied by my father and myself.

By December first the other two had closed down on account of sickness, and we two were left alone to handle all the blacksmithing work of the section.

Meridith was then one of the terminals of a stage route forty miles long, and was served by a coach and six horses which made daily trips. The teams were so divided that they were all shod at our end of the journey, which meant shoeing six

horses every morning before eleven o'clock throughout December and January. After February second, sleighs were put on and the shoeing of these teams eased up a bit.

But all during those three long winter months, while the other shops in the place were closed, we handled practically every repair job, all the shoeing of horses in the village and from outside farms, together with 150 yoke of oxen. It kept us hustling every minute for 14 to 15 hours out of the twenty-four.

My father was an old man, and could work only 10 hours. He did the fitting and I drove and did the heavy work. But in spite of the temper it took to keep me going, it was worth every ounce of strength put into my hammer during those days. It meant independence and muscle-building, and put the grit and timber into my young body that I would never have gotten from the cotton mill.

One example of a good day's work stands out in my memory as typical of the kind of stuff the work put into me. On this particular day, I recall putting shoes on my twenty-second horse in nine minutes by lamplight. Ordinarily I wanted about seven minutes to do the job in broad daylight, and on a quiet horse at that.

Now for my little tale about the shoeing job with a moral. Some four years ago I was called out of town to see what could be done to a year old colt.

I found him walking on his ankles bent forward and the toes of his feet.

The joints had buckled forward until they touched the ground and he was carrying his full weight upon them and upon the toes. On examination I found that the joints could be bent back towards their normal position, and accordingly suggested as a logical remedy, a shoe that would tend to keep them there.

I made the shoes after the pattern illustrated. The heels were abnormally high, of course, and the shoes were set over the toes about two inches.

As the heels had grown down long and the toes were worn off short, I made arrangements to have the shoes removed often and the heels lowered a little at a time, until the feet were again restored to their natural plane.

This treatment proved a success from the start, and in another year I heard that the colt and his mate





were to be sent south for work on a farm. From all outside appearances the colt's feet were perfectly normal at the time he left, and when I again heard of him two years later, I learned that the crippled colt had stayed sound and done his work without any trouble or return of his former ailment.

I drew a valuable lesson from this experience, and if it has not already suggested itself to my readers, I state it here:

If a colt goes wrong from the start and seems to be worthless, don't give him up as a bad proposition until you have done some good, hard common-sense thinking about his trouble. You would be surprised to see what can actually be done to a young horse's bones when they are young and plastic. His feet can be made to grow in line and legs and joints easily straightened—if one only uses a little thinking and perseverance. The only skill required is that needed to design proper appliances and in their careful and scientific application. Results are bound to be gradual, so don't ever attempt to overdo and try to get results by

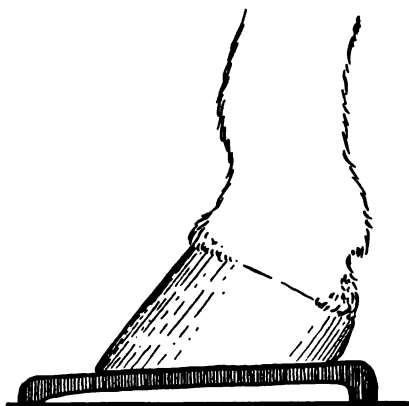

MR. MALOON'S SHOE FOR CURING A COLT WITH BUCKLED JOINTS

a radical form of treatment such as that used by the Chinaman who drank a whole bottle of medicine in order to get well in a hurry. Too great haste will only make matters worse instead of relieving them.

Let the colt exercise and be made to grow by giving him plenty of good food. As he grows his bones will harden, and if properly directed in their growth, formation and position, your reward will be the development of an animal who is perfectly normal—and the chances are, that because of the extra care which has been given to him, he will be even superior to the average horse. Such has often been the case and it is a reward worth striving for.

## The Oxy-Acetylene Plant—4

Its Installation, Operation, and Torch Manipulation

DAVID BAXTER

Readiness

Before taking up preheating we will consider some pointers frequently overlooked. When preheating is underway, it is good practice to carefully examine the gages, regulators, et cetera, to make sure everything is ready to proceed with the welding.

Get together the approximate amount of metal filler and the kind of flux to be used in welding the job, and have them handily placed for instant use. If no checking system is used, the filler and flux should be weighed or measured. This enables the operator to tell just what this part of the job costs after he has weighed back the amount left over. After some practice it is not difficult to estimate the cost of a weld in advance, as we are nearly always asked to do. A carefully kept cost record of every job handled will help to estimate quickly in the future.

While the preheating is continuing, it is well to save time by getting ready for the cooling or annealing in advance, or at least make certain that everything is ready. If the piece does not go into the annealing oven, get the asbestos scrap ready, or any other good non-conductor of heat which you intend to use, so the piece may be banked as soon as the torch-work is finished.

If quenching is contemplated, or other artificial cooling is intended, have the water near at hand.

Choose the right size tip and fit it to the torch; also have another torch in readiness, or at least other tips prepared.

Examine the hose and connections to see that they are not liable to work loose or spring a leak. This "getting ready" is cutting the time and cost of making the weld, and is oftentimes the means of saving a weld or preventing the loss of one altogether.

### Preheating

Expansion and its twin, contraction, are the worst stumbling-blocks to a perfect weld by the oxy-acetylene process. Contraction must be reckoned with on equal terms with expansion, but we will take the former up later under another heading. There is really but one way to control expansion, and that is by preheating, or bringing the article to be welded to a certain degree of heat before applying the welding flame.

There are but few set rules or instructions concerning what and where to heat. The best thing to do is to learn what expansion is and its cause and effects. The purpose of this chapter is to try to explain preheating and its relation to expansion. If we can lead the operator to grasp the meaning of expansion

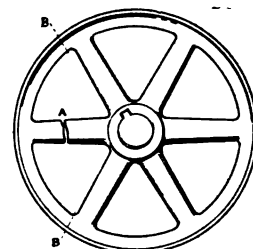

FIG. 1.—PREHEATING OFTEN REMOVES THE NECESSITY OF GROOVING, AS IN THE CASE OF A CRACKED SPOKE IN A WHEEL. HEATING THE RIM AT POINTS B-B OPENS THE CRACK AT A ENOUGH TO ALLOW THE WELDING TO BE CARRIED THROUGH THE SPOKE

we feel that he will be able to learn to control it easily. A beginner should preheat everything all over until he learns to localize the heating.

When the torch operator knows and remembers that all metals expand or enlarge on being heated, he can more readily understand why he should preheat.

Preheating means, in this instance, heating in advance or before starting to weld. The greater the temperature of heat applied, the faster and greater the expansion. This expansion is in reality a stretching or pulling apart of the grains or structure of the metal.

To illustrate: Take a dry sponge and pour water on it gradually. As it absorbs the water, it will expand or enlarge to its full capacity for holding water. Now, metal absorbs heat and in much the same manner; but when metal reaches a certain fullness of heat it melts and runs away.

If water is poured upon one part of a sponge, barring capillary attraction, this part only will enlarge. This is true of metal. Heat applied to one section or area of a casting will cause that part to expand. This expansion will be out of proportion to the cooler parts. If the heat is raised to the full expanding limit while the balance of the job is cold, it can be seen that the unequal expansion will result in an internal or open crack.



To illustrate: take a flat piece of metal say, one-eighth of an inch thick and a foot square. Heat an area of two inches in diameter at or near the center of the flat piece. The heated spot will expand as the temperature rises and will attempt to push outward toward the cold metal. If the cold metal is not strong

ly high temperature of the flame. It is better to be on the safe side and raise the temperature of the preheating more than is thought necessary. In ordinary cases the preheated section should be a bright-red heat. Exception to the last two statements is made in aluminum and other metals of low melting point; go slow with them.

has to be done it should be carried on as shown in Fig. 2.

A common forge may be used in preheating smaller castings. Very large castings may be placed over a make-shift grating located outdoors and walled around with firebrick. The bricks should be placed loosely, leaving cracks to furnish draft for the charcoal fire to be built around the casting. The top should be covered over with asbestos paper, in absence of a movable oven, having holes punched in it to allow the air to circulate. The fire is made so as to distribute the heat and prevent a severe concentration of it on any part of the casting. Asbestos paper is very well suited to preheating, as it admits of easily making an opening any place to enliven the fire or do the welding. It does away with the necessity of uncovering the whole casting.

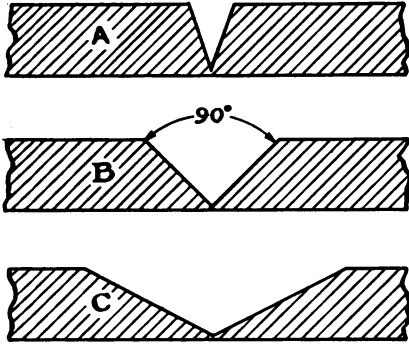

In preheating the smaller kinds of castings it is safer to bring the entire casting to a bright red heat. The preheating temperature should be maintained throughout the welding operation.

In case of very large jobs it is often inconvenient or impossible to preheat the entire piece. However, in large work the internal strains are not so noticeable, and do very little harm. As the expansion and contraction occurs within itself, so to speak, there is small danger of an open fracture. This is due perhaps, to the fact that the center of a large body of metal is more porous, or rather, the structure is not so closely knit and has coarser grains. It seems that the coarse grains push in between each other when the strain comes upon them, at any rate we can localize the preheating more. However, it is well to preheat a considerable area around the part to be welded, bringing the temperature up to a red heat and keeping it so while welding.

Whenever possible, the preheating should be maintained throughout the welding procedure and for some time afterward. The operator can protect himself by placing asbestos in such a way as to minimize the amount of heat striking his face and hands. Use several layers if necessary.

Where a great many similar castings are to be welded, it is good practice to have a special preheating oven. This should be made as nearly a non-conductor of heat as possible, and should have appliances for moving.

**FIG. 2.—THE RIGHT AND THE WRONG WAY OF GROOVING:**  
**A—WRONG. A NARROW ANGLE IS HARD TO WORK AND MAKES A WEAK WELD.**  
**B—THE CORRECT ANGLE—ABOUT 90 DEGREES.**  
**C—WRONG. A WIDE ANGLE MAKES A WEAK JOINT AND REQUIRES TOO MUCH METAL.**

enough to resist the pressure of expansion, it will be compelled to warp or crack to make room for the outpushing metal. If the metal is strong enough to resist the pressure, a distortion will be the result. The heated spot will bulge up or down and perhaps also crack. It will remain in such shape because the subsequent contraction upon cooling does not alter the distortion.

Preheating may be done with the welding flame in some cases altho it is more often greater economy and a safer proposition to heat with some other agency.

Torches of natural gas, oil, or gasoline; or charcoal, wood, or coke fires are frequently more economical because of the saving of welding gas and the saving in time. Besides, these means take care of the expansion better because they are more easily enlarged and controlled.

This brings us to the real reason for preheating. It is to allow, or rather, to cause equal expansion, or in other words to prevent unequal expansion.

A cubic inch of metal expands a certain amount, differing slightly in different kinds of metal. A large piece will expand in proportion. Therefore, we should heat a heavy section faster and hotter than a light section. Be careful not to apply the heat to the heavy section too suddenly. Endeavor to have the heavy and light sections reach the expanding limit at precisely the same moment. This limit of expansion is the proper time to commence welding operations.

Preheating sometimes eliminates the necessity of grooving a crack, as in the case of a cracked spoke in a wheel. See Fig. 1. The expansion opens the crack enough to allow the welding to be carried to the heart of the spoke. Care should be taken in this instance, not to over-heat, as we are liable to open the crack too much, and by adding too much new metal cause distortion of the wheel when it contracts. Start welding when the crack has opened or spread to one-sixteenth of an inch unless the wheel is very large.

If the place to be welded is not fully expanded, it will naturally expand more when the welding flame is applied, and this expansion will be sudden on account of the extreme-

In cases where it is not necessary to heat the entire job or where its

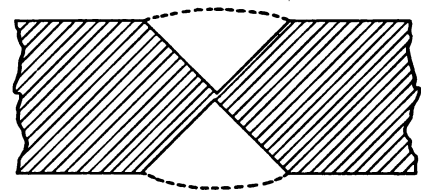

**FOR CASTINGS OVER ONE-HALF INCH THICK, GROOVE ON BOTH SIDES. (DOTTED LINES INDICATE METAL TO BE ADDED)**

shape permits of localizing the preheating. it may be confined to a small area by laying wet cloths around the part to be welded, or by arranging to have water running over the parts we desire to cool. An example of localizing the heat here follows: A gear-wheel with a tooth broken out, quite heavy, and measuring about six feet in diameter and six inches across the face was to be welded. The preheating was carried to a red-heat on each side of the miss-



ing tooth by keeping wet rags on each side.

Now while we strongly recommend preheating all-over, there are numerous jobs that need no preheating whatever. After the operator has learned the effect of expansion, and the way it operates, he can soon judge whether to heat the entire job or not. And from the action and effects of expansion, he can tell when he does not need to preheat.



A—THE EXCESS ACETYLENE FLAME



B—THE STANDARD NEUTRAL FLAME



C—THE EXCESS OXYGEN FLAME

FIG. 3—THE THREE COMMON FORMS OF THE OXY-ACETYLENE FLAME

The example, given to explain expansion, might be used again to show how to tell whether to preheat or not. Let us take the same flat plate and heat a corner or two of it, say a couple of inches of it. Here the expansion will nearly all be outward and as there is nothing to hold it back, there will be no strain or crack. And unless the heat is applied too many times there will be no distortion, because there will be nothing to retard contraction.

This principle may be applied to all lugs, bosses and sharp corners of any castings, regardless of size.

All manner of small castings may be welded without preheating if there is nothing to retard expansion and contraction.

The Flame

We now come to the flame and at the start we want to impress upon the mind of the operator the fact that the flame has as much to do with welding as any other part of the process, and he must know how to adjust it. Expert operators adjust the pressure of the gases passing through the torch, differently for different kinds of metal, also for obtaining greater or lower temperatures. Sometimes a very hot flame is better; sometimes a flame of lower temperature is more suitable. About

midway between the highest and lowest temperature is what is termed the standard working-flame. This is the flame most often used and is a safe one for the beginner. It is also called the neutral flame, neutral, because neither gas is admitted in excess of the other.

To obtain the standard working flame (Fig. 3) first, light the acetylene at reduced pressure; then, after being sure the oxygen regulator is set at the desired pressure, open wide the oxygen cock at the torch; then open the acetylene cock at the torch sufficiently to get two white cones in the flame. Now close the acetylene cock gradually, watching these two cones carefully. When they merged into one, they form a neutral working flame, correct for nearly all classes of welding.

With the torch of some makers the cones referred to are not exactly cones. They could be better described as tongues, being more often flat. The double cone is a three tongued flame; the middle tongue being twice as long as the other two; and all three joined into one where it leaves the torchtip.

When this three-tongued flame, which has an excess of oxygen, is merged into one to form the neutral flame, it is again not exactly a cone; it is blunt or slightly rounded at the point. It is nearly white and is about five-sixteenths of an inch long. If we pull it down finer it gets more blunt and has a slight appearance

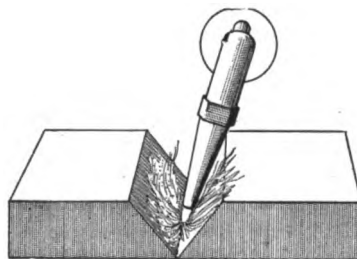

FIG. 4—THE FLAME IS INTENSELY HOT, THE TEMPERATURE RISING TO ABOUT 6,300 DEGREES FAHR., BUT HAS LITTLE VOLUME

of having a knob on the end. This flame is not as efficient as the longer one.

The operator should not be content with a correct adjustment of the flame at the beginning of a job, but should test it once in awhile during the welding by opening the acetylene cock until the double tongue appears, then close it gradually until there is but one cone.

The working flame has a temperature of about 6,300 degrees Fahrenheit

at its tip. This is a tremendous heat in degree of intensity but not in volume; (Fig. 4) therefore the metal may be overheated easily in one place and underheated in another. With steel, copper, and aluminum, the quality of the metal may be injured by too high a temperature.

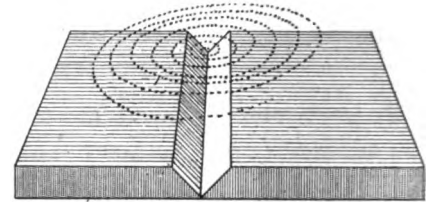

FIG. 5—IT IS ESSENTIAL THAT THE FLAME BE MOVED IN SMALL CIRCLES—NOT HELD TOO LONG AT ANY ONE POINT

The effect of the tremendous temperature of the flame at the point of application is to bring the metal to a melted state very quickly, so it may flow together and mix with the metal added by the torch operator. Perfect steadiness of the flame is one of the essential factors in doing good work.

The oxy-acetylene flame, when properly adjusted and manipulated, does not alter the welded pieces of metal. With an excess of oxygen the metal is liable to be oxidized, and an excess of acetylene tends to carbonize; the standard neutral flame has neither gas in excess. There are times though when it is an advantage to use either one or the other in excess. For example, in welding aluminum. In this case a flame having a slight excess of acetylene is best. This excess reduces the temperature and as the aluminum has a low melting point, it is easier to weld without burning, by using a flame of lesser heat. For metals having a high melting point the opposite is true. There is danger of ruining the work in either.

The steadiness of flame, previously referred to, means a constant pressure in the gas and even maintenance in the mixture; it does not refer to steadiness of the hand.

The steadiness of the hand is not as essential for ordinary work as keeping the flame in motion either to the right or left in very small circles, or back and forth. This rotary motion (Fig. 5) is an insurance against burning the metal. Some operators claim that the direction of the movement will influence the strength of the weld, but this is somewhat doubtful in its strict sense. The welder can satisfy himself as to



whether a rotary motion to the right or to the left is more beneficial on various metals. But it is certain that the finish or appearance of the weld may be improved by the motion or directing of the flame. The expert can direct or blow the metal almost at will by his manipulations of the flame. He can handle the flame very much like he would a paint-brush, literally brushing the molten metal from the high spots to the hollow spots.

Although the inner cone of the welding flame is the welding point,

An improper mixture will sometimes cause the flame to ignite in the mixing chamber causing backfiring, but this is more often caused by holding the torch so the flame is thrown back around the tip: the tip soon becomes hot enough to light the gases before they can reach the outlet. A sharp cracking or series of cracking noises will notify the operator to pay attention to the torch and perhaps cool the tip. This he may easily do by shutting off the gases and dipping the tip into water.

(To be Continued)

### The Care of Tires\*—3

Helpful Hints for the Automobile Repairman

Deterioration, contrary to the general impression, is not necessarily a result of age but is largely influenced by the conditions under which tires are held in stock.

When exposed to the light and sun, especially to the hot summer sun, the rubber will dry out, harden, and the efficiency and life of the tire will be impaired. As a protection from light, when held in stock by a dealer or carried as an extra by the user, the best tires, after final inspection at the factory, are wrapped in paper—this also serves to preserve the shape of the tire. It is recommended that the paper wrapper be left on extra tires or, if the paper be removed, it is a good plan to put the tires into service for a short time until the rubber becomes soiled—filling the pores and covering with a thin coating of dirt will have a preservative effect.

takes place, the nerve or fibre of the rubber is destroyed, with consequent effect upon the flexibility and durability. A dark, dry room at a temperature of from 40 to 50 degrees is most favorable for retarding chemical action in the rubber tread, side walls and the adhesive "friction" stock between the layers of fabric.

When car is laid up for the winter, or for other reasons is not used for several weeks, the stale air should be removed from the tires. Partially inflate with fresh air—enough to round out the tires and cover them with muslin or other material to protect from the light. The weight of the car should be supported by blocks or jacks, so that there will not be any weight on the tires.

Before using tires in the spring examine them carefully for cuts on the outside, remove tacks and small nails, reinforce any small breaks in the fabric inside and lubricate fabric, also inner tube, with powdered mica. Make sure that rims are not dented or otherwise irregular. Apply a thin solution of graphite, shellac and alcohol.

The use of foot and emergency brakes is taught to the new car owner early. Being somewhat nervous and timid, the driver may apply the brakes very hard with the result that one or both rear tires receive tread damage as shown by the accompanying illustration. Locking the wheels will not, under all conditions, bring the car to an immediate stop; the momentum and weight will frequently cause the rear wheels to

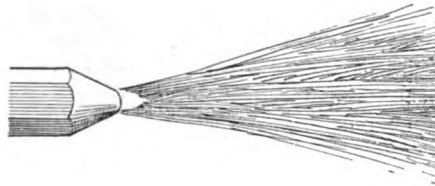

FIG. 6—AN EXCESS OF OXYGEN IN THE WORKING FLAME CAN BE DETECTED BY THE RAGGED END OF THE INNER CONE

the outer or enveloping flame is not altogether useless or wasted. It preheats the work, and protects the inner cone from the inert nitrogen of the air. It protects the melted metal from oxidation, as it has a greater affinity for oxygen than has the metal.

An excess of oxygen in the working flame can be detected by the ragged end of the inner cone (Fig 6). An excess of acetylene can be detected by there being more than one cone, or two tongues—one being longer and less luminous than the other.

A carbonizing flame will cause the metal to glow. An oxidizing flame will cause the metal to boil. The neutral flame is a very pale blue, with no ragged edges. An excess of oxygen changes the flame to a dark blue. An improper mixture of gases in the torch will cause the weld to be full of pin-holes.

The bright light of the oxy-acetylene flame causes a strain on the eyes; therefore, it is best to wear smoked or blue-glass goggles. The operator soon becomes accustomed to wearing goggles, and can see as well for good welding as with the naked eye.

Do not work with the eyes too close to the work as the heat is liable to crack the glass in the goggles. Never use goggles having celluloid or other composition instead of glass; they may ignite and blindness will be the result.

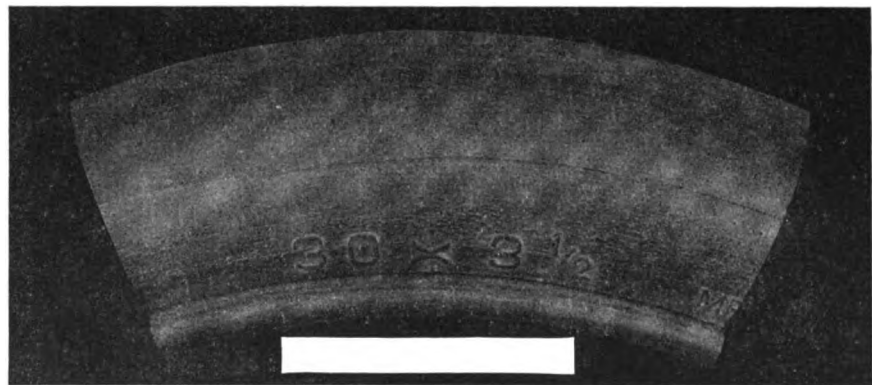

DETERIORATION:—CRACKED CONDITION OF RUBBER KNOWN AS "GUM CHECKING"

Tires should not be kept in a warm place for any great length of time, as light and heat will cause the sulphur to come to the surface and make the rubber minutely porous. After "gum checking" or oxidation

\*Courtesy Firestone Tire & Rubber Co.

slide along for a considerable distance and grind off the tread of the tires in the same manner that street car wheels receive flat spots. When ground down to the fabric in this way, the tread should be given early attention to protect the fabric from



decay and the weakening effect of moisture, and to prevent dirt from working under the rubber with probable separation of other tread portions. Inspect inside of case and repair any threads or plies of fabric broken from strain.

Sharp, quick turns or fast driving at curves, usually causes rear wheels to slide and skid sideways.



**SEVERE APPLICATION OF BREAKS:**—This shows resultant damage from severe application of brakes. The wheel being locked, tire scraped along until the tread rubber was ground off.

This not only wears off the tread rubber quickly but, on account of the unusual strain, is particularly harmful to the fabric body of the tire.

It is recommended that the service (foot) brakes be given occasional inspection. Any difference in adjustment of brake drums can be discovered by jacking up rear axle so that neither wheel rests on the ground; then start engine and engage clutch. If, upon application of foot brakes, one rear wheel revolves and the other does not or, if one wheel revolves faster than the other, the tire on the one turning slowest receives more strain and, under the circumstances, excessive wear to the tread rubber may be expected.

The clutch plays an important part in the efficiency of the car and in the service of the tires. It is essential, therefore, that same be kept in good order so that it will take hold smoothly when gears are engaged. Usually the taking up of loose bearings and frequent lubrication will insure the desired results. Avoid letting in the clutch quickly while the engine is running fast—such treatment is not good for either car or tires.

Spinning the driving wheels in mud, snow or on slippery roads may grind off the tread rubber and some-

times snag the cover along the entire wheel circumference; it is not unusual for the tread to be torn loose from the fabric in places.

Punctures used to mean a lot of trouble for tire users, but the refinements in rims now make quick changes possible and this bugaboo no longer worries the average driver.

A filler will *not* fit the same in

of strain distribution to suit the construction. No advantage over solid tires can be claimed for fillers unless the fillers are resilient. To secure the desired flexibility, fillers are invariably made of pliable materials—and being of this nature they will flatten under weight.

Objectionable developments are circumferential friction from lack of uniform filling out of case and from displacement at road contact, weight and effect of centrifugal force, heat and separation. Rims are caused to sag and become out of round, also the clinches may be spread and twisted as a result of weight and pounding action; rim cutting above beads of case, pinched tubes, and others annoyances can frequently be traced to these irregularities. Tire manufacturers waive the guarantee and responsibility for tires when a substitute for air is used. Car manufacturers discourage excess weight to wheels, especially on the driving wheels—this is particularly true with small cars, the power and rear axle system not being suitable for moving an unusual drag.

An engineer does not depend upon the strength of materials *alone*, to make a safe railroad bridge or building—it is necessary that the structures also be designed along the right principles.

A successful tire must be properly designed, i. e., the shape suitable for the size of the section and a correct balance is an essential thing; the tire must be strong enough to ren-

tires of various makes, owing to the difference in the design, contour and size of tires. Some filler manufacturers recommend that, after being in service for a short time, more filler be added to take care of the stretching and other changes in tires.

Resiliency being a prime requirement of pneumatic tires, it is hard

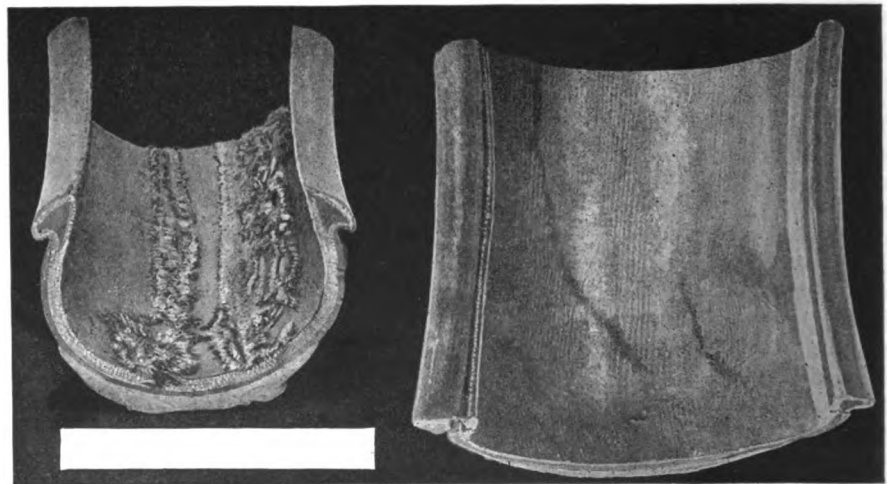

**TIRE FILLERS:**—At the left: Fabric badly chafed by Filler. At the right is shown chafing of fabric and the lack of uniform filling out of case. The damage at bead resulted from the very firm pounding against clinch of rim from inside of case.

to conceive of an improvement on air for cushion and elasticity. If fillers be too soft, the hinging action of tires will be localized and not permit

der good service but not too thick, heavy or stiff to prevent distribution of strains and stand the flexing action in side walls.



Extra thicknesses and weights added to tires will cause additional heat and interfere with the radiation. Tread attachments or covers creep, chafe, heat and stiffen the tread to such an extent that fabric breaks are caused by a localized hinging action in side walls.

If rims become rusted from water working around beads when tires are run soft or through neglected cuts in the tires, or from neglect to put proper fittings on the valve stem, the rust should be removed with emery paper and rims painted with a coating of aluminum, graphite and oil or

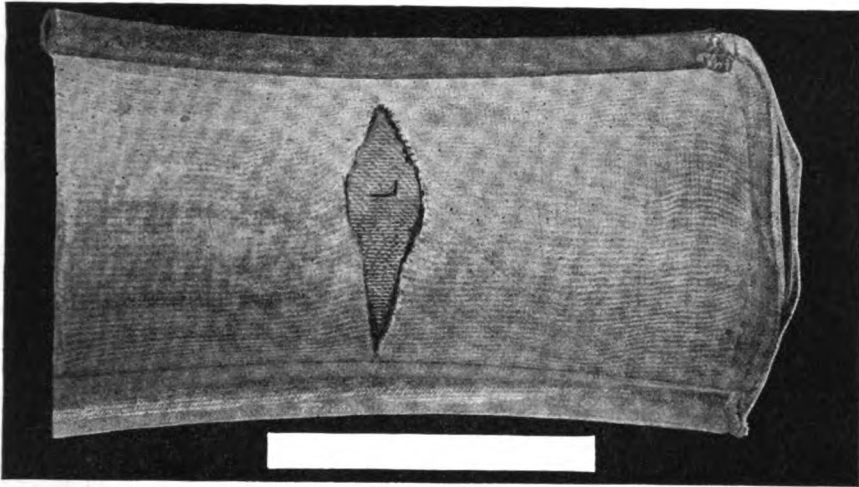

**TIRE FILLERS:**—This shows the impression made on fabric on inside of case by loosely woven cloth usually employed for filler cover.

It is not advisable to use reliners in new tires because they tend to flatten the tires similar to under-inflation and, in many ways, interfere with the design and intended action. If made of flexible material, and well constructed, reliners are a good thing in old tires having separation and breaks in the fabric, and which would not, without reinforcement, be serviceable. Under such circumstances, reliners strengthen the tires, protect inner tubes from being pinched by the fabric and often make it possible to secure a great deal of mileage.

Protection from rim cutting is not to be obtained by any particular type of tire but depends rather upon the design, quality and usage. No good tire of any standard type will be cut by any standard rim, if properly used. On the other hand, any type of tire will be injured if subjected to abuse. Under inflation, dented and irregular rims, excessive loads, tire fillers and stiff reliners are the common causes for cutting and breaking above beads.

The flanges of a rim may be battered down and become rough from running a tire deflated for a considerable distance; the next tire, applied, is sure to be cut above the beads.

Tires, carrying heavier loads than those for which designed, may develop breaking at the beads where engaged by clinches of rim.

other good preservative solution. When applying a tire, be careful that flap does not slip underneath bead and crowd it in clinch of rim.

Under the impression that they are oversize, it is not uncommon for tires to be applied to rims of wrong size—for example, using 36x4½ tire on a 36x4 rim. The diameter of this rim is approximately 28 inches and the diameter of the beads of the tire approximately 27 inches (Q. D. Clincher type) or approximately 26 inches (Regular Clincher type) therefore it becomes necessary to stretch and strain the beads considerably. The 4½ inch beads are not constructed to fit a 4 inch rim and will not engage properly in the clinches. Good results cannot be secured when beads are strained and crowded in this manner. Correct oversize tire for 36x4 rim is 37x4½.

When removing tires from rims, do not overlook pushing valve stem of tubes up far enough in tires so that it will not be necessary to pound fastening device of rims in order to release beads of cases. Rims are sometimes dented from pounding them in this way.

When chafing, cutting or breaking extends all around beads on both sides, repairs are expensive and not to be recommended. If the injury only extends for a short distance over one or both beads, a skillful repair man can make a good job at a reasonable cost.

## The Smith in The Daily News

### Odd Mention of Anvil Ringers and Knights of the Forge in the News of the Day

#### Not as Stupid as He Looked

A stupid looking "rookie," from a nearby training camp, halted before a blacksmith's forge, the proprietor of which was forging a shoe, and eyed the performance with much interest. The brawny smith, dissatisfied with the man's curiosity, held the red hot iron suddenly under his nose, hoping to make him beat a hasty retreat.

"If you give me a half a dollar I will lick it," said the soldier.

The smith immediately took half a dollar from his pocket and held it out. The cunning son of Mars took the coin, licked it and walked away whistling, "The Girl I Left Behind Me."

#### Horseshoers Adopt Mediation

Through a national agreement entered into at a recent conference, held in Cincinnati, Ohio, the possibility of future strikes and lockouts of horseshoers throughout the United States has been eliminated, according to an announcement made after a conference between officers of the Master Horseshoers National Protective Association and of the International Union of Journeyman Horseshoers.

#### Bill to Regulate Horse Shoeing

A bill has been introduced in the New York State Senate which would require the examination and registration of all persons engaged in horseshoeing in the state of New York. This bill has the approval of Prof. Moore of Cornell and the entire staff of Cornell Agricultural School as well as veterinarians throughout the state. A committee was named to take up the matter with Senator Wicks and Assemblymen Geiersbach, Martin and Davis to assist in every way in the passage of the bill.

#### Blacksmiths Conquer Stubborn Mules

It took real patriotism and grit to shoe the 95 mules of the Sixth Regiment Supply Company, but the blacksmiths of Fitchburg, Mass., proved equal to the occasion.

Kicking, biting and using every trick that a mule knows, the animals resented the efforts of the knights of the forge to attach Uncle Sam's shoes to their feet, but one and all were successfully roped up and shod by the sturdy smithies.

It was necessary to employ sentinels from the regiment to keep the crowd back from the smithy's door. The mules were driven up, hitched to the army wagons, and a half dozen drivers into the shop at a time. As fast as a mule appeared he was tackled and, if he showed any signs of fighting, was given a dose of the "war bridle," or if that failed, the stocks were brought into play. These never failed.

The blacksmiths started work about 1:30 P. M., and, before they quit for the night, 49 mules had been treated by them. During the work, one smith had some skin scraped off his face when a fractious mule made a pass at him. The next day, Sunday, another worker was kicked in the stomach, but neither were seriously injured.



## The Blacksmith's Heaven

TOM BOWLES

An Angel and a Blacksmith  
Started up to Glory's gate,  
But when passing close to Hades,  
The Angel whispered, "Wait!"  
"I've a place I want to show you,  
It's the hottest in all Hell,  
Where the folks who never paid you  
In eternal torment dwell."

And behold! the Blacksmith saw  
there

His old debtors by the score;  
So a chair he grabbed and shouted—  
"Let me wish for nothing more;  
I'm content to sit and watch them  
As they sizzle, singe and burn,  
Let me crank the spit a little,

—Give each one another turn."  
Said the Angel, "Come on, Blacksmith,

There the Pearly Gates I see."  
But the Blacksmith only murmured,  
"This is Heaven enough for me!"



## Heats, Sparks, Welds

Here's a cheerful motto: SMILE!—But don't hang it on the wall; wear it.

Started that catalog library yet?

Have you dusted off the ol' price list yet? Isn't it about time?

It's a poor smith who will try to sell poor work at a poor price.

Sherman must have had it in for hell when he gave that famous definition of his!

War hasn't exterminated our big herd of Bufalos yet. Better write in for yours now.

What's become of the old-fashioned man who used to pay his shoeing bill with spuds?

An opportunity to help brother smiths; tell us about your success with side lines in your shop—your actual experience with them and what success you had.

Bill Forger says, "Ever notice what a funny combination loose methods in business and tightness in money matters are?" Yep, we agree with him, we have.

'Bout this time of the year folks think they need a spring tonic. We heartily rec-

ommend the following as the best yet: take a good, sharp saw to one good sized pile of wood and shake thoroughly.

Ever think of it this way—a debt, every man owes his business, is to advertise it.

Do you know that if your tools lose their temper they can't work well? How about yourself and your temper?

Don't wait until New Year's day to get a flying start—begin now. See how you'll be warned-up by the time next month comes around.

Chances are that your competitor has both eyes open for business and his mouth closed on the war talk. Business may be war—but too much war may kill business, if you let it.

If your competitor talks about you, don't talk back. Remember that old one—covered with gray whiskers now, but still good: "Every knock's a boost." It's as true today as ever.

Speakin' of the well-known "rolling stone", we might say that neither does the still stone gather any "moss"—the s. s. being, of course, the man who doesn't go out and hustle for business once in a while.

Ol' Phil Osofy says to us, t'other day, says he, "Mebbe the reason sum fellars hain't a-hankerin' after any bookkeeping, is thet it might show them up as to how good failures they be." Guess Phil is right there too. What do you think?

Time is money. In justice to yourself don't squander it upon tasks that are not worth the price. First, get a rational point of view of the worth of your time; then lay out a plan for spending it to the best advantage; and finally, stick to it!

Running the smith shop without the aid of a craft paper, is like walking from San Francisco to New York—it can be done, and folks are doing it occasionally; but isn't it a whole lot easier to take the train that's been put there for your benefit?

And if a tool stands around idle, what happens?—rust, and what not. A worker with tools may aptly compare himself with them. And if he treats himself as he knows a good tool should be treated, he's sure to render as efficient service as a keen, finely-tempered tool.

What's become of the ol' pump in front of the shop? Been replaced by a "gas" pump, eh? Blacksmiths, who are serving this popular "drink" to autoists, are making good money on the side; and besides a gasoline pump helps to advertise the business and draws a lot of the auto repair trade into the shop.

Summer's a good time to cultivate new business as well as crops. Some bright day, hire a rig and leave your helper to handle the shop for a few hours. Drive around the surrounding country and see how farmer Janes stands on having that wagon rebuilt, how butcher Smith feels about having his delivery rig re-painted, and merchant Brown his auto overhauled. Just remind them that if they want to have the work done at all for some time to come, they had better speak quick, for you are going to be pretty busy.

If you shoe horses, know something about the horse. That's simple logic. So if you are serving farmers, know something about their needs. Farming has progressed remarkably during recent years. Power is being used to an extent almost undreamed of a few years ago. And the

blacksmith who wants the profitable repair business that is sure to go hand in hand with modern farming, should take time to learn something about farming—modern, progressive farming methods.

If you have any knocks, kicks or boosts for your craft paper, jes' get out your ol' power hammer and bellows and knock and blow away. This is your paper, and the more we hear from our readers as to what they think of it, the better paper it will prove to be. Tell us what you like, what you don't like, what you would like to see that hasn't appeared in print yet. And if you can send along something yourself in the shape of an original contribution—something describing your way of doing things, a handy kink, or description of some home-made shop device—why go to it. The more the merrier!

Business methods are as necessary in the blacksmith shop as elsewhere. Why not apply them then? If you must extend credit, do so in a thoroughly business-like manner. Next time a new customer shows up and doesn't want to pay cash, ask him about his trading elsewhere, and look up his record. If he hasn't been paying his grocery bills, you can safely figure that he will be slow when it comes to settling up for his smithing. So let your answer be gauged accordingly. Cash, of course, is the best way. But sometimes credit is necessary—or you lose a good customer. It shouldn't be extended, however, to every Tom, Dick and Harry—investigate first.

Once in awhile we hear a man say, "I have so much work to do, I don't know where to begin." And we notice that when such is the case, that he usually stands around doing nothing all the time he is complaining, instead of being busy doing some of his work. Several chances to one we'll bet the man isn't lazy. He probably simply lacks system in his work. When a hard-working anvil pounder tells us he hasn't any time to read, we can bet—and pretty safely at that, that that man hasn't been systematized. Think it over, and if you need a little mental, self over-hauling, why not get busy and do it? It's wonderful what a man, who is always "too busy", can accomplish when he stops for awhile and gets his bearings.

From the Kansas Association comes this little tale of "progressive business methods", as related by a practicing attorney:

"While I was prosecuting attorney for a Kansas town a few years ago, I had occasion to cause the arrest of a blacksmith, the smallest member of the trade I ever saw, on the complaint of a man twice his size, who had been badly battered by the smith. When the case came on for trial before the police judge, defendant appeared as his own counsel, and when called upon to interpose any defense he had, he shoved back his chair, clearing a small space, and waltzing around with his arms in belligerent motion, said:

"Davis came into my shop and said, 'Brown, I owe you thirty cents.' I said, 'Davies, you owe me forty cents.' He said, 'Brown it is only thirty cents.' I said, 'Davies, you are a ——— liar,' and the books proved that he was a ——— liar, and I hit him."

"This is, I believe, the only system of bookkeeping on record so devised as to show the particular brand of prevarication used by a customer, but all hail to Brown for the pains he took to keep his accounts in such shape that he could go into court and testify to their accuracy."



# Our Honor Roll

**AND STILL THEY COME!**  
 More and more readers are taking advantage of "Our Honor Roll" every month and it is becoming more difficult each month to find a place on the list of Honor Subscribers. If you do not know what a saving you can make by taking advantage of Our Long-Time Rates look over the table of rates and see just how you can save money and at the same time insure your subscription account. Sharpen your pencil and get down to actual figures and then get your name on this list of Readers who are paid up well in advance.

### KANSAS STILL LEADS

Last month Kansas took the lead away from Utah with a 20-year subscription. We've got to hand it to Kansas and Mr. Krehbiel for real progressiveness. Wonder who'll be next? Just wait and watch this page, and see what happens.

U. S. and Mexico      Canada      Other Countries.

2 yrs.....\$1.60 and save \$.40.....\$2.00 and save \$.50.....10 sh. save 2 sh.		
3 yrs.....2.00 and save 1.00.....2.70 and save 1.05.....14 sh. save 4 sh.		
4 yrs.....2.50 and save 1.50.....3.20 and save 1.80.....18 sh. save 6 sh.		
5 yrs.....3.00 and save 2.00.....3.75 and save 2.50.....1 £ save 10 sh.		
10 yrs.....5.00 and save .5.00.....7.00 and save .5.50.....1 £ 14 sh. save 1 £ 6 sh.		

Send your order and remittance now—today. Don't wait until you forget all about it. You'll never regret it. Our subscription insurance saves you money. The sooner you begin saving, the more you save. There is no better time than NOW.

NAME	Subscription Paid to	NAME	Subscription Paid to
E. A. Krehbiel, Kans.	May, 1917	D. M. Kile, Okla.	Apr., 1925
The Fix-It Shop, Utah	July, 1915	G. Gullgren, Iowa	Apr., 1925
J. A. Torray, Mass.	Dec., 1913	F. Fredericks, Minn.	Mar., 1925
W. C. Watt, Kansas	Dec., 1910	V. Priessnitz, Wisc.	Mar., 1925
I. J. Stites, N. Y.	Jan., 1919	E. Price, Illinois	Feb., 1925
Waddington Farm, W. Va.	Mar., 1928	D. C. Garber, Ohio	Feb., 1925
A. MacLean, Ont., Can.	Feb., 1928	J. H. Kurk, Illinois	Feb., 1925
W. W. Egly, Pa.	June, 1927	E. R. Hiteshue, Ohio	Feb., 1925
E. A. Krehbiel, Kan.	May, 1927	H. F. Schreiber, Pa.	Feb., 1925
S. Forman, N. J.	Apr., 1927	J. S. Damm, Iowa	Jan., 1925
H. Dyresen, S. D.	Apr., 1927	J. M. Withers, Hawaii	Jan., 1925
G. Shoemaker, Pa.	Mar., 1927	D. Teebien, Nebr.	Dec., 1924
C. Geiger, Penn.	Mar., 1927	N. B. Quick, Pa.	Dec., 1924
F. Everts, Conn.	Mar., 1927	F. H. Jarvis, Indiana	Dec., 1924
A. Tillman, Calif.	Feb., 1927	George Tatum, Jr., Fla.	Dec., 1924
J. W. Haught, Ill.	Feb., 1927	I. Clark, Va.	Dec., 1924
F. Roschy, Pa.	Feb., 1927	A. N. Estes, Va.	Dec., 1924
J. W. Howes, Md.	Feb., 1927	J. Bailey, Manitoba	Dec., 1924
W. Stocker, Texas.	Feb., 1927	E. G. Naylor, Md.	Dec., 1924
W. Pontius, Iowa	Feb., 1927	Halvorson Brothers, S. D.	Nov., 1924
M. Goller, Pa.	Feb., 1927	P. Schicks, Washington	Nov., 1924
A. A. McLean, Nev.	Feb., 1927	H. E. Snyder, Oregon	Nov., 1924
C. M. Adams, Conn.	Jan., 1927	C. A. Stewart, Ky.	Oct., 1924
C. Radeleff, Iowa	Jan., 1927	J. Richenecker, N. Y.	Oct., 1924
P. J. Kauth, Ill.	Dec., 1926	W. L. Berthoff, N. J.	Oct., 1924
A. H. Gooding, S. Aust.	Dec., 1926	J. W. Hewson, S. Africa.	Sept., 1924
H. Pass, Minn.	Dec., 1926	Ed. Larson, N. D.	Sept., 1924
A. Grandam, Ill.	Dec., 1926	R. T. Monk, Illinois	Sept., 1924
Plataeu Shoeing Shop, Colo.	Dec., 1926	W. T. De Young, Illinois	Sept., 1924
C. J. Hale, Wash.	Dec., 1926	C. W. Taylor, Pa.	Aug., 1924
John H. Schneider, Cal.	Dec., 1926	Charles Wells, Colorado	Aug., 1924
J. C. Smith, Washington	Dec., 1926	H. G. Weaver, Pa.	Aug., 1924
H. Grimm, Utah	Dec., 1926	Working Men's College, Vict.	June, 1924
F. L. Matlocks, Ark.	Sept., 1926	F. M. Kenoyer, Nebr.	June, 1924
E. B. Jones, Wisc.	Sept., 1926	O. Anderson, Ariz.	May, 1924
J. Taylor, Calif.	Sept., 1926	R. C. Frederick, N. D.	May, 1924
W. H. Branch, N. C.	Oct., 1926	H. L. Fenton, New Mexico	May, 1924
J. Clarke, Jr., Queens, Aust.	Aug., 1926	J. Carl, Iowa	May, 1924
I. Boles, Ohio	July, 1926	J. E. Little, Pa.	May, 1924
J. A. Buchner, Mich.	July, 1926	H. I. Brenzle, N. Y.	Apr., 1924
H. Mitchell, N. Y.	July, 1926	W. E. Parr, Iowa	Apr., 1924
M. Broton, N. D.	June, 1926	F. Stramek, Nebr.	Apr., 1924
A. Schmitt, Nebr.	June, 1926	L. A. Hulen, Calif.	Apr., 1924
D. Ackland & Son, Man.	May, 1926	J. E. Ray, Minn.	Mar., 1924
H. Pirret, Ore.	May, 1926	A. Hulstrand, N. D.	Mar., 1924
J. Stinchlar, W. Australia.	May, 1926	W. F. Riske, Wisc.	Mar., 1924
P. Sova, Oregon	May, 1926	P. F. Seibert, Calif.	Mar., 1924
E. P. Digan, S. Aus.	Apr., 1926	H. Roeschwetter, Mo.	Mar., 1924
P. A. Peterson, Iowa	Apr., 1926	W. E. Briant, N. J.	Mar., 1924
G. F. Bowers, Okla.	Apr., 1926	A. Bosch, N. Y.	Mar., 1924
W. Poehel, Oregon	Mar., 1926	D. Van Valkenburg, Mass.	Feb., 1924
A. Garver, Ohio	Feb., 1926	A. R. Johnson, R. I.	Feb., 1924
C. Burton, Mass.	Mar., 1926	F. Jacobs, Ohio	Feb., 1924
J. Murphy, Calif.	Jan., 1926	A. J. Ferry, Illinois	Jan., 1924
J. F. Murphy, Nev.	Jan., 1926	E. K. Walker, Calif.	Jan., 1924
F. Kearnes, Illinois	Jan., 1926	H. D. Erakine, Vermont	Jan., 1924
J. N. McIntire, Pa.	Jan., 1926	E. Fowler, Pa.	Jan., 1924
W. Post, N. Y.	Jan., 1926	Breen & Son, Ireland	Dec., 1923
Powell Brothers & Whitaker, Eng-land	Jan., 1926	M. Lamoreaux, Ohio	Dec., 1923
O. Temple, Idaho	Jan., 1926	C. R. Davis, N. Y.	Dec., 1923
N. Karolewicz, S. Dak.	Jan., 1926	F. W. Copeland, Kansas	Dec., 1923
E. L. Lain, N. Y.	Dec., 1926	J. L. Tomlin, Kansas	Dec., 1923
J. A. Hulvey, Illinois	Dec., 1926	H. A. Davis, N. Y.	Dec., 1923
Williams & Turner, W. Va.	Dec., 1926	E. H. Troyke, Illinois	Dec., 1923
J. J. Devine, N. J.	Dec., 1926	D. B. Johnson, Iowa	Dec., 1923
P. Nelson, Minn.	Dec., 1926	S. Horton, Calif.	Nov., 1923
M. Kennedy, Tas., Australia.	Dec., 1926	J. Spratt, Mass.	Nov., 1923
H. Jones, England	Dec., 1926	F. Watkins, N. H.	Nov., 1923
A. J. Wassmuts, Idaho	Nov., 1926	F. Koppnis, Ala.	Nov., 1923
J. G. H. Mallett, Queens, Australia	Nov., 1926	Y. C. Lenert, S. Australia.	Oct., 1923
A. W. Speir, Ohio	Nov., 1926	W. E. Abell, N. Y.	Oct., 1923
W. E. Clepper, Texas	Nov., 1926	W. E. Turner, Man.	Oct., 1923
G. H. Inley, Mass.	Nov., 1926	A. J. Brookman & Co., Vict.	Sept., 1923
L. Krause, Ind.	Oct., 1926	Australia	Sept., 1923
Reynolds Brothers, Pa.	Sept., 1926	C. Nelson, Nebr.	Sept., 1923
F. W. Krens, Calif.	Aug., 1926	J. Hughes, Ohio	Aug., 1923
C. E. Allen, Nebr.	Aug., 1926	H. M. Anderturen, Calif.	Aug., 1923
A. E. Spangberg, Oregon	May, 1926	Camp Brothers, Texas	Aug., 1923
		L. C. Larson, Iowa	July, 1923
		S. Effenar, South Africa	July, 1923

NAME	Subscription Paid to	NAME	Subscription Paid to
G. L. DeWitt, Mont.	July, 1923	J. Ackerman, Indiana	Sept., 1921
W. W. Gregg, Texas	July, 1923	A. Harper, Mont.	Aug., 1921
W. R. Stroupe, N. C.	July, 1923	L. E. Bonton	Aug., 1921
O. C. Young, Michigan	June, 1923	J. Watson, S. Africa	July, 1921
Otto Sippel, Pa.	June, 1923	R. Goldschagg, S. Africa	July, 1921
A. Chapman, N. Y.	June, 1923	C. Hammerstram	July, 1921
C. Birely, Md.	June, 1923	A. S. Pratt, New York	July, 1921
F. H. Stoupe, Pa.	June, 1923	E. H. Spain, Ariz.	July, 1921
J. C. Stover, Pa.	Apr., 1923	L. H. Strange, Vict., Aust.	July, 1921
W. Schoonover, Pa.	Apr., 1923	W. Urquhart, New Zealand	June, 1921
J. M. Rumire, Iowa	May, 1923	W. Voigt, S. Africa	June, 1921
Lowndale Brothers, Mo.	Mar., 1923	J. M. Werl, Pa.	June, 1921
J. Carswell, Ark.	Mar., 1923	E. Toll, New Zeal.	June, 1921
G. E. Glaxier, Ohio	Mar., 1923	G. Johnson, Kans.	May, 1921
F. Gath & Co., S. Africa	Mar., 1923	S. Budds, New Guinea	May, 1921
T. Bradley, N. S. Wales	Mar., 1923	H. Baker, Australia	May, 1921
L. T. Needham, Illinois	Feb., 1923	F. E. Smith, Vermont	May, 1921
G. C. Disinger, Miss.	Feb., 1923	A. J. Hatch, Maine	May, 1921
J. Wieber, Minn.	Jan., 1923	W. Cornwell, Pa.	May, 1921
Z. A. Enos, Minn.	Jan., 1923	W. F. Kline, Kansas	May, 1921
W. G. W. Bise, Calif.	Jan., 1923	J. Kirkbride, N. J.	May, 1921
F. S. Bishop, South Africa	Jan., 1923	T. Holloway, Kans.	Apr., 1921
J. Curran, Arizona	Jan., 1923	W. Winget, Vt.	Apr., 1921
S. P. Harney, Mont.	Dec., 1922	A. A. Johnson, N. D.	Apr., 1921
W. Breckner, Okla.	Dec., 1922	D. H. Laird, N. Y.	Apr., 1921
J. Pabina, Nebr.	Dec., 1922	A. J. Prue, N. Y.	Apr., 1921
P. Frederickson, Iowa	Nov., 1922	C. A. Butler, Ohio	Apr., 1921
L. O. Leuris, Illinois	Nov., 1922	E. Mossner, Queens, Australia	Apr., 1921
W. Lawson, New Zealand	Nov., 1922	E. Lindblad, Nebr.	Mar., 1921
W. O. Grant, Calif.	Oct., 1922	F. Bowen, N. Y.	March, 1921
W. H. Miller, Iowa	Oct., 1922	W. F. Tippey, Mich.	Mar., 1921
J. S. Lee, Wash.	Sept., 1922	J. T. Rehm & Son, N. Y.	Mar., 1921
A. O. Martin, Idaho	Sept., 1922	W. C. LeBow, Mo.	Mar., 1921
O. A. Mortimer, Idaho	Sept., 1922	William Pate, Mo.	Mar., 1921
H. J. Hyatt, Washington	Sept., 1922	A. T. Jameson, Colorado	Mar., 1921
N. J. Skow, Iowa	Sept., 1922	C. Alexander, N. Y.	Mar., 1921
A. D. Standiford, Washington	Sept., 1922	J. Fencl, Wisc.	Mar., 1921
T. Temkiewics, Quebec	Sept., 1922	H. Cornils, Oregon	Mar., 1921
A. Pellifer, Ohio	Aug., 1922	C. Schmid, Nebr.	Mar., 1921
W. D. Valentine, Iowa	Aug., 1922	J. Schwarzmann, D. C.	Mar., 1921
G. Hoffman, N. Y.	July, 1922	M. Stuetzer, Minn.	Mar., 1921
J. Erman, Ark.	July, 1922	J. Potthoff, Nebr.	Feb., 1921
W. K. W. Hansen, Pa.	June, 1922	N. E. Hart, Okla.	Feb., 1921
Robert Tochter, Calif.	June, 1922	C. Knudson, Iowa	Feb., 1921
J. Van Marter, N. Y.	June, 1922	S. Button, Kans.	Feb., 1921
E. Schnelle, Ohio	Apr., 1922	N. F. Hartsoe, Mo.	Feb., 1921
J. Bunker, Iowa	Jan., 1922	I. Qoeppire, N. Y.	Feb., 1921
F. Norrie, Yukon Ty.	Jan., 1922	R. E. Worthington, N. Y.	Feb., 1921
J. Needham, Kans.	May, 1923	B. E. Doggett, Kansas	Feb., 1921
E. Anders & Son, S. Aus.	May, 1922	Shellhaas & Fry, Colorado	Feb., 1921
Louisa Carriage Works, Va.	May, 1922	J. Tooes, Kansas	Feb., 1921
S. Wilkin & Sons, N. Y.	Apr., 1922	J. W. Wilson, Mo.	Feb., 1921
R. H. Kuhrt, Iowa	Apr., 1922	W. T. Wilson, Indiana	Feb., 1921
S. Smith, Texas	Apr., 1922	J. Schmid, Nebr.	Feb., 1921
A. J. Neill, Vt.	Mar., 1922	E. Snee, New York	Feb., 1921
W. Muckle, Ontario	Mar., 1922	A. R. Skerritt, New York	Feb., 1921
M. Burke, Ariz.	Mar., 1922	W. H. Starkey, Kans.	Feb., 1921
J. W. Hodge, N. Y.	Mar., 1922	W. Singleton, Pa.	Feb., 1921
J. W. Haar, La.	Mar., 1922	E. N. English, Iowa	Jan., 1921
D. W. Smith, Rhode Island	Mar., 1922	H. Becker, Ill.	Jan., 1921
E. A. Dillon, Nev.	Mar., 1922	G. Tice, N. J.	Jan., 1921
D. F. Kuster, Washington	Mar., 1922	J. Briere, Vt.	Jan., 1921
C. Robertson South Africa	Feb., 1922	A. Bartlett, Vt.	Jan., 1921
P. C. Oldroyd, Utah	Feb., 1922	E. H. Manley, Mo.	Jan., 1921
V. Vanourek, Wisc.	Feb., 1922	Neufeld & Giesbrecht, Kans.	Jan., 1921
W. Parker, Mich.	Feb., 1922	W. C. Abbott, Ohio	Jan., 1921
J. DeGlopper, Mich.	Feb., 1922	Feldmeyer & Schanke, Mo.	Jan., 1921
Nordstrom Bros., Kans.	Feb., 1922	A. Josepfit, Colorado	Jan., 1921
G. F. Johnson, Michigan	Feb., 1922	C. L. McNall, Mo.	Jan., 1921
J. Schoenberger, Ohio	Jan., 1922	A. Turley, Kansas	Jan., 1921
A. Burgett, Pa.	Jan., 1922	A. Seidel, Nebr.	Jan., 1921
R. H. Keith, Iowa	Jan., 1922	W. Ruple, Pa.	Jan., 1921
W. Parks, Ohio	Jan., 1922	N. A. Englund, Iowa	Jan., 1921
O. Danemann, Minn.	Jan., 1922	O. Gerhardtstein, Ohio	Jan., 1921
O. Stenning, S. D.	Jan., 1922	W. C. Rutter, Illinois	Jan., 1921
J. J. Klima, Nebr.	Dec., 1921	J. L. Jester, Mo.	Jan., 1921
J. Boyer, Mich.	Dec., 1921	G. A. Moffatt, Yukon Ty.	Jan., 1921
C. F. Shaw, Man., Can.	Dec., 1921	F. Fisher, S. D.	Jan., 1921
W. Blaker, Ohio	Dec., 1921	A. L. Schwartz, Iowa	Dec., 1920
W. Lamberton, N. Y.	Dec., 1921	S. Barber, Iowa	Dec., 1920
Scheffley & Schmitt, Pa.	Dec., 1921	A. Warner, Idaho	Dec., 1920
O. Furry, Kans.	Dec., 1921	J. W. Ivie, Utah	Dec., 1920
E. A. Pierson, Okla.	Dec., 1921	O. A. Huff, Pa.	Dec., 1920
J. Robertson, Scot.	Dec., 1921	J. T. Rowe, Iowa	Dec., 1920
J. Lauer, Mo.	Dec., 1921	W. Parsons, Ontario	Dec., 1920
A. Brause, Ohio	Dec., 1921	Eiseler Brothers, S. Dak.	Dec., 1920
E. A. Abbey, Ohio	Dec., 1921	J. Krabulec, Illinois	Dec., 1920
J. Ingvarson, Minn.	Dec., 1921	L. F. Kellholz, Pa.	Dec., 1920
A. F. Millebrandt, Mich.	Dec., 1921	F. Markig, Minn.	Dec., 1920
J. H. Truful, Jr., Illinois	Dec., 1921	S. Wright, New York	Dec., 1920
R. C. Brown, Mo.	Dec., 1921	T. P. Consonide, Mass.	Dec., 1920
C. Beyer, N. D.	Dec., 1921	J. D. Fox, Nebr.	Dec., 1920
G. Nichols, Okla.	Dec., 1921	W. Troneer, Washington	Dec., 1920
F. H. Joelin, Mass.	Dec., 1921	A. G. Palmquist, Minn.	Dec., 1920
J. B. Schelder, Indiana	Dec., 1921	J. E. Richards, Pa.	Dec., 1920
J. H. Ickes, Pa.	Dec., 1921	J. Berthelsen, N. S. W., Aust.	Dec., 1920
E. Willis, Colorado	Dec., 1921	G. Sykes, N. S. W., Aust.	Dec., 1920
A. Elliott, England	Nov., 1921	B. Billing, N. Y.	Dec., 1920
J. Beam, N. J.	Nov., 1921	W. Obergfell, N. J.	Nov., 1920
F. Kolarik, Iowa	Nov., 1921	L. F. Smith, Ohio	Nov., 1920
A. McNab, Scotland	Nov., 1921	D. Codere, Illinois	Nov., 1920
J. Delane, Nebr.	Nov., 1921	C. Franzen, New York	Nov., 1920
A. Marks, N. S. W., Aust.	Nov., 1921	J. Delane, Nebr.	Nov., 1920
O. E. Stevenson, Ill.	Nov., 1921	J. H. Staats, Mo.	Nov., 1920
J. Meier, Minn.	Nov., 1921	George F. Wardle, S. D.	Nov., 1920
W. Knouff, Ala.	Oct., 1921	H. C. Strine, Pa.	Nov., 1920
O. M. Johnson, Miss.	Oct., 1921	C. M. McNutt, Mass.	Nov., 1920
J. K. Glinlekt, Mich.	Sept., 1921	J. M. Mapes, New York	Nov., 1920
H. Feldus, Nebr.	Sept., 1921	W. Condon, New York	Nov., 1920
R. Murray, Calif.	Sept., 1921	F. Strieff, Wisc.	Nov., 1920
A. Hammond, Calif.	Sept., 1921	L. P. Mortensen, Michigan	Nov., 1920
P. Weddel, Kans.	Sept., 1921	A. W. Brennenman, Indiana	Nov., 1920
		J. Gribble, S. Aust.	Nov., 1920

NAME	Subscription Paid to	NAME	Subscription Paid to
J. Ackerman, Indiana	Sept., 1921	J. Ackerman, Indiana	Sept., 1921
A. Harper, Mont.	Aug., 1921	A. Harper, Mont.	Aug., 1921
L. E. Bonton	Aug., 1921	L. E. Bonton	Aug., 1921
J. Watson, S. Africa	July, 1921	J. Watson, S. Africa	July, 1921
R. Goldschagg, S. Africa	July, 1921	R. Goldschagg, S. Africa	July, 1921
C. Hammerstram	July, 1921	C. Hammerstram	July, 1921
A. S. Pratt, New York	July, 1921	A. S. Pratt, New York	July, 1921
E. H. Spain, Ariz.	July, 1921	E. H. Spain, Ariz.	July, 1921
L. H. Strange, Vict., Aust.	July, 1921	L. H. Strange, Vict., Aust.	July, 1921
W. Urquhart, New Zealand	June, 1921	W. Urquhart, New Zealand	June, 1921
W. Voigt, S. Africa	June, 1921	W. Voigt, S. Africa	June, 1921
J. M. Werl, Pa.	June, 1921	J. M. Werl, Pa.	June, 1921
E. Toll, New Zeal.	June, 1921	E. Toll, New Zeal.	June, 1921
G. Johnson, Kans.	May, 1921	G. Johnson, Kans.	May, 1921
S. Budds, New Guinea	May, 1921	S. Budds, New Guinea	May, 1921
H. Baker, Australia	May, 1921	H. Baker, Australia	May, 1921
F. E. Smith, Vermont	May, 1921	F. E. Smith, Vermont	May, 1921
A. J. Hatch, Maine	May, 1921	A. J. Hatch, Maine	May, 1921
W. Cornwell, Pa.	May, 1921	W. Cornwell, Pa.	May





## Machine and Tool Smith

### Fundamentals of Lathe Practice

JAMES STEELMAN

#### Special Uses of the Lathe

One of the many uses to which the blacksmith's engine lathe may be turned is *polishing*. It is not sufficient, however, that he be merely informed of this fact; he must know just how to go about it if he would meet with the greatest success. In this article we shall attempt to outline the most approved methods of using the lathe for polishing operations, and if directions are followed carefully, there is no reason why the blacksmith should not turn his lathe to good advantage in this direction and have sure success.

In polishing on the lathe two things demand particular attention: provision for rapid speeds, and keeping the splatterings of gritty material used in polishing from getting into the bearings. Not much can be said about the latter other than to warn the operator to use great care to protect his exposed bearings. For this gritty material is very damaging to the bearings. As a general rule there are only a few bearings to care for, and a little common sense will dictate just how to protect them.

The matter of speed though, demands more thorough consideration. Methods of providing for rapid speeds have been fully outlined in a previous installment of this series under the title: "Boring and Grinding". It will accordingly be unnecessary to repeat these particular methods here.

The *speed* at which the *surface* should be running when polishing is to be done with any one of the following materials is about 5000 feet a minute. The materials are: emery, alundum, carborundum or a loxite cloth. This is about the standard

speed for the working edge or an ordinary grinding wheel. Naturally, to get this speed, special provisions will have to be made. In utilizing the suggestions referred to above, it must be remembered that the thing that has to be rotated at high speed is not a small grinding spindle rigged up on the lathe, but the big spindle in the headstock of the lathe. This is a heavy piece. Accordingly, the belt connections from the main shaft of the shop to the lathe itself will have to be substantial enough to take care of this matter. So likewise, with the pulleys concerned.

The actual *rotational* speed of the lathespindle will vary with the diameter of the work. The small work will require the highest rotational speeds; and the big work, the lowest. This is, in a way, fortunate. The reason is that high speeds may cause the work to break loose from the lathe and result in a serious accident. It is therefore a good thing that the larger the work, the lower the speed.

But after all is said and done, the best thing to do is to secure the work so that there will be no danger. The user of the lathe for polishing must be on the alert as to how the work is to be held in place. Furthermore, if the work is unbalanced, trouble

assuming that the work is on steel. It should be noted that polishing is done for two more or less distinct reasons. In the first place, ordinary work will upon inspection disclose irregularities on the surface. There will be tool marks, perhaps chatter marks, possibly scratches, and so on. It is desirable to remove these in order that the job may present a proper finish. The second relates to the desirability of producing a highly finished surface—a real polish.

When the work has received its last attention from the cutting tools, it is ordinarily ready for any polishing finish that is to be applied. If the work is only moderately rough from the tool marks, etc., then Nos. 60 and 90 are suitable. No. 60 is used first, the cloth being pressed quite firmly against the rapidly rotating work. This is continued until scratches and tool marks have vanished. As to the pores in the metal, these may still be seen, but they should not appear very prominently. We now substitute No. 90 cloth and continue with it until any effects in the way of markings that may have remained over from the use of No. 60 have disappeared. However, it sometimes happens, that when the cloth loaded with the fine powder follows that loaded with the coarser, markings

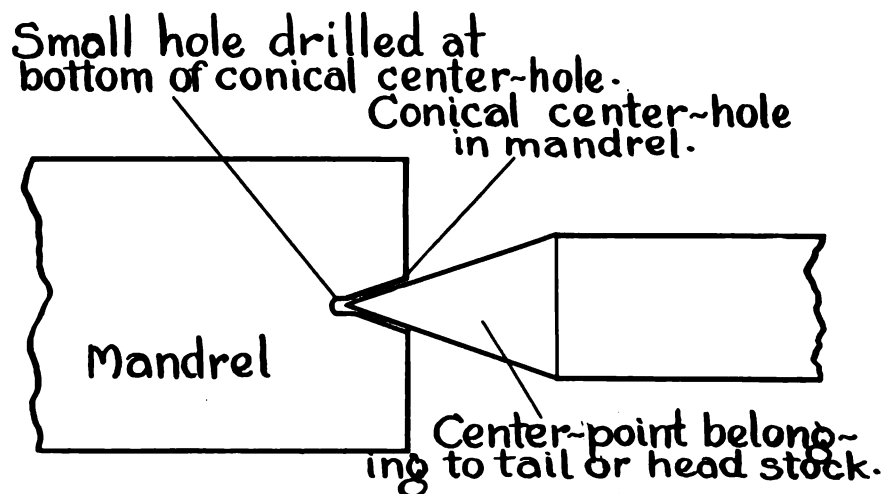

FIG. 1.—SECTION THROUGH MANDREL AND CENTER-POINT

may result. Thus, we might have a piece on the lathe that was distinctly heavier on one side than the other. It may be possible in many cases to provide a counterbalance that will cause the lathe to work smoothly and prevent the work from breaking loose.

*Emery cloth* is obtainable in various sizes of grain. These variations correspond to various conditions of the work and to such results as may be desired. For the moment, I am

seem to reappear. When this occurs, we return to the use of the No. 60. It may be said, in general, that whenever a fine cloth seems to reveal old marks, the operator should at once go back to the coarser cloth. The successive use of No. 60 and No. 90 will give a good polish under ordinary conditions. If a very brilliant polish is desired, then we may add a third cloth—one loaded with a quite fine emery. In working with emery cloth, we make use of lard



oil, putting it on either the cloth or the work. The fingers are about as good as any other instrument for applying the oil, which should be spread—of course while the work is not moving.

If the steel surfaces to be polished are plain cylindrical surfaces or flat surfaces, we may proceed as follows: Suppose, for example that we have a plain cylindrical surface to treat. Such a surface might be the curved exterior of a collar or of a plain hub belonging to a flange. Instead of backing the emery cloth with one's hand, we may use a piece of soft wood. We have first to mount the work on the lathe. We may use a mandrel for this. Naturally, this mandrel will itself be mounted between the head stock center and the tail stock center. Since we are going to use very high speed, it will be well to make sure that everything is right. We examine the pointed ends of the two centers and note whether they are perfect. If the tip is broken off the center, we do not take any chances, but go to work and repoint the center. We likewise examine the center holes in the ends of the mandrels and note whether they are perfect. It will be recollected perhaps that the center hole consists partly of a conical depression into which the center point accurately fits and partly of a little fore-hole which obliterates the pointed bottom of the conical depression and extends in a little further into the metal of the mandrel. The object of this small bore-hole is to prevent the sharp point of the center coming into actual contact with the mandrel's material. A little reflection should show one that, after a mandrel has been in use, the conical depression may have become sufficiently worn to let the point of the center in far enough to press into the mandrel's substance. This is a wrong condition—wrong at all times. Perhaps no great harm may come from this contact. It is best, though, to take no chances at all. We come now to a slightly different matter. It is important, when using the mandrel for high speeds, that both centers shall have deep penetration into the conical depressions. We should make sure that this is the case. We mount the work securely on the mandrel and put the mandrel between centers. The centers must not hold the mandrel loosely. At the same time, the mandrel has to turn on the tail stock center. We arrange a dog to turn the mandrel along with the face plate. If the set screw is to be forced up against a part of the

work liable to damage from this source, we may use a small piece of copper between work and set screw, being careful to get a firm grip on the copper to prevent its getting loose under high speed. If we have to have a loose mandrel between centers in order to get easy rotation, then there is probably something wrong with the fit of the tail stock

sides of the work. If both parts balance one another and are about the same form and size, we will have covered the matter very well. Or, we may use *two* dogs instead of one. These should, of course, be duplicates and should be arranged on opposite sides. Let us also remember, that with a substantial mandrel, not too long, properly mounted between

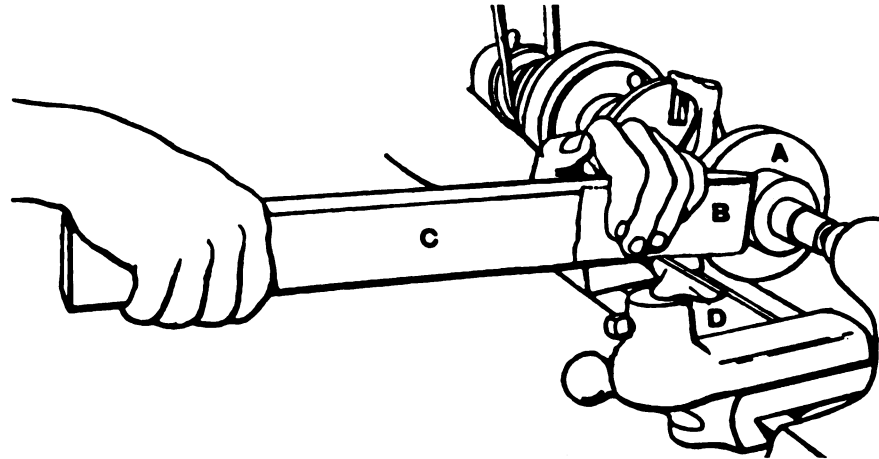

FIG. 2—A HANDY DEVICE FOR POLISHING A FLANGE\*  
 A—The piece to be polished. B—Strip of emery cloth. C—Piece of wood.  
 D—Support for C.

center-point and the conical depression at the end of the mandrel. One thing that might be wrong is that the axis of the conical depression is not exactly in line with the axis of the mandrel. We are going to use high speed; so we do not want a loose mandrel at the start nor one that will work loose as we go on. We take care to see that we have an easy running mandrel that has *practically no play*; using plenty of oil, however, at the tail center. And we see to it that both center points extend well into the mandrel. The shortness of the mandrel should correspond to the weight of the work. A heavy piece of work should by no means be put onto a slim mandrel. Further, the mandrel should be about as short as possible, considering the work. Then make sure that the work itself is not heavier on one side of its axis than on another. If it is heavier on one side, we may at times weight it on the opposite side to counterbalance. But there must be no danger of this counterbalance working loose. Furthermore, the dog which is used to force the mandrel to rotate with the face plate may create an unbalanced face plate, unless we give attention to the matter. This might prove serious, as we are going to rotate the face plate at high speed as well as the work. The dog may ex-

tend in opposite directions on *both* centers and with the work and the face plate properly counterbalanced, we ought to have no trouble. In this we assume that the work itself is all right—that it contains no protuberances that might break off under centrifugal force.

The center in the tail stock will have no motion, but the mandrel—or the work itself, perhaps—will be turning on it. As the speed is high and but little play is desired, we may easily get a "hot box". *Plenty of oil should be used.* Let it be applied frequently. Furthermore, if the work itself is mounted on the centers, the polishing friction may develop enough heat to cause sufficient *expansion* to unduly tighten the work between centers. We must be on the lookout for this, and loosen the tail center, if necessary. If the work or the mandrel and the tail center should run dry because we have not been attentive to oiling, or for any other reason, the friction will naturally cause heat and consequent expansion. The "hot box" thus produced may result in a burnt point on the center and a dangerous accident because of the rapidly rotating pieces flying free from the lathe. When using high speeds one should be very alert as to lubrication matters.

In order to prevent a troublesome, unbalanced condition of the

\*By permission Robert H. Smith, from "Textbook of Advanced Machine Work," published by the Industrial Education Book Co., Boston.



face plate, we may sometimes use a dog of light weight, made of malleable iron. Even so, it would seem best to use a dog with its weight distributed fairly equally to opposite sides of the piece being held for rotation.

All the foregoing precautions are to be understood as requisite for all work carried by a mandrel between centers, whether we use emery cloth or some other polishing agent.

polishing tool slowly along the work, one object being to prevent the formation of grooves. We may use Nos. 60 and 90, as when we backed the cloth with the hand.

We may polish the flat surfaces of a disk in much the same way. We set the tool rest, which is to supply our point of support, two or three inches off from the work, arranging the rest so that it parallels the disk. We shift our polishing board or

properly be made of leather. The hollowed-out places are arranged near the hinged end and are given a size and position permitting them to inclose the shaft between them. The hole will be made just a trifle large, since we are to use one layer of emery cloth between the clamp and the shaft. The emery cloth is used in the form of a strip of about the same width as the clamp. However, this strip of cloth is not secured to the clamp, but is wrapped *once* around the shaft. When the clamp is put on, it comes into contact with this strip and not with the work. The ends of the strip will lie between the handles of the clamp and may in fact be held in place by a finger of the hand holding the two handles. In order for the finger to secure a purchase on the cloth, the latter is shifted between the handles enough to bring a little of it on the outside. We now have a flat loop of emery cloth enveloping the shaft and held to its work by the wooden clamp. We use our fingers for oiling either the work or the cloth. The right hand holds the hinged end of the clamp and the left the handles. Nos. 60 and 90 may be used to produce a fair polish on steel, provided the lathe work was finished moderately smooth. If we wish to go on to a high polish, we may use No. 120 and flour after concluding operations with the coarser cloths. However, we may find that we have better success with this final finishing, if we use no wooden implements as aids but rely wholly on the hand. Keep in mind the necessity of shifting the clamp along with the loop of emery cloth lengthwise of the shaft in order to prevent the formation of grooves. An approved method of shifting is to move the clamp back and forth in short movements. The clamp should be adjusted so that *pressure* may be applied by the left hand when it forces the handles together. Never let the clamp remain in one position; otherwise grooves will result.

In all of the foregoing work, it is assumed that the surface to be polished has been finished rather smoothly—that whatever tool marks or scratches might be present are only of moderate depth. If, on the contrary, the surface to be polished is rather rough, then we may advantageously begin our polishing with a coarser cloth than No. 60. Such cloths as No. 46 or No. 54 may be found necessary.

If we desire to polish *brass* or *copper*, we may pursue much the

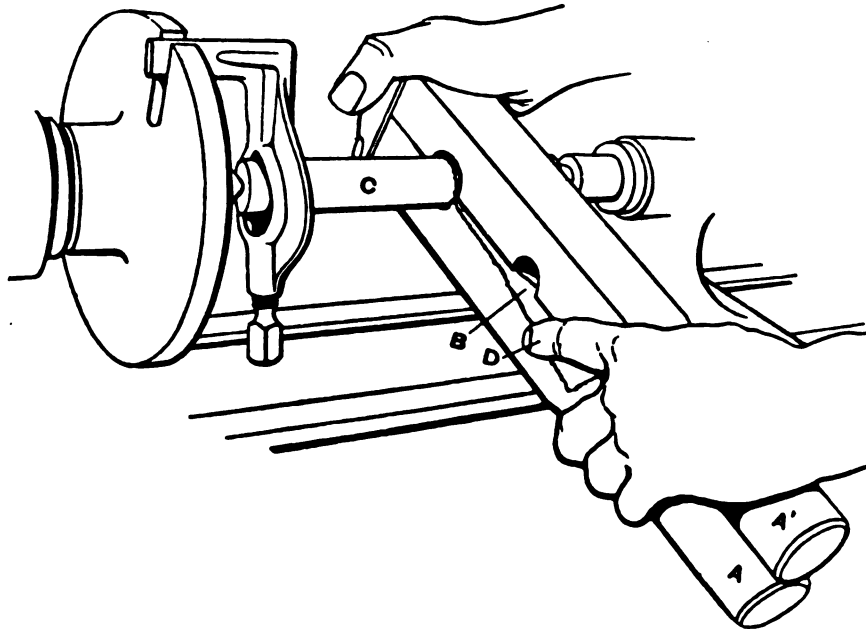

FIG. 3—A CLAMP FOR POLISHING A SHAFT\*

A-A'—The two halves of the wooden clamp B—one end of loop of emery cloth which is wrapped round the work. (Note that B is slightly displaced.) C—The shaft being polished. D—Forefinger of left hand holding down end of emery cloth.

A wedge-like piece of pine board may be used endwise to hold the emery cloth up against the work. The tool rest may be used to supply a kind of pivot upon which the under edge of the board may be supported and upon which it may at the same time be maneuvered. The emery cloth may be simply laid around the forward end of the board and held in place by the left hand, the right hand taking care of the rear end of the board. That is to say, with regard to the emery cloth, we cut it into a strip of about the same width as the board and perhaps 15 inches long. We fold this around the business end of the board. In this way, we provide an emery cloth covering for the end edge of the board. As the emery wears off the cloth, we may shift the strip and bring a new section into place. The rest may be clamped two or three inches from the work. As the work rotates and we hold the edge of the board with its emery cloth covering up against the surface to be polished, we *shift our*

stick with the covering of emery cloth from the outside towards the center. We do not move steadily in towards the center; but maneuver the board in and back, in and back, in *short strokes*, so managing these back and forth strokes as to approach the center slowly. One thing to always keep in mind is to avoid the formation of grooves. Our back and forth movements should, if carefully carried out, take care of this. Oil (lard oil) is spread either on the cloth or the work.

A long cylindrical piece, such as a steel tube or a steel shaft, may often be advantageously treated by using a kind of wooden clamp as a means of holding the emery cloth evenly and firmly against the surface of the work. We mount the work on a mandrel, if the work is a tube, or on its own center holes, if a shaft, and arrange the dog or dogs. The clamp consists of two wooden pieces hinged together at one end and provided with two semi-cylindrical notches, one in each stick. The hinges may



same methods as with steel; only in this case we begin with a finer emery cloth on account of the softer character of the metal. For instance, for work machined to an ordinary degree of smoothness, we start with, say, a No. 90 cloth, and finish with a No. 120 flour and what is termed crocus cloth. If on the other hand, the work, when the cutting tools have finished, is rather rough, we may begin polishing with a No. 60 cloth, passing on to the finer grades later.

Where work—steel, cast iron, brass or copper—is to have drilled holes in the polished surface, it is approved practice to defer the drilling operation until after the polishing is completed. It is perhaps easier to protect the general surface while drilling than it would be to do the polishing of a surface with holes in it.

I have given account of a wooden clamp used to hold a flat loop of emery cloth against work and thus effect a polishing operation. This method, however, while good for *external* surfaces, is useless where we have to deal with the interior of a cylinder. Perhaps the best advice here is this: We may remove tool marks and scratches by means of a suitable *lap*. When these have been gotten rid of, we may use emery cloth backed by the hand to produce a polish. One form of lap which is adapted to certain cylindrical work, is made and used as follows: In this case, the lap is to be rotated between the lathe centers and the work is to be held on the carriage. A square bar of iron is selected whose diagonal cross measure is less than the diameter which the lap is to have. Depressions at the ends are to be arranged for the reception of the lathe centers. Cautions as to such depressions have been set forth at the beginning of this article. The bar is now made the central core for a cylinder of lead which is cast on and around it. It may be better to form the depressions for the centers *after* this casting operation. At any rate, when the lead is in position and the depressions are ready, we put the whole on the lathe and cut the lead surface to a true cylinder whose axis is coincident with the line between centers. The lap is operated for polishing—or rather, grinding—by springling emery powder on it and causing it and the work to come together. If the work is mounted, not only on the carriage, but also on the *compound rest*, then we will have a means of bringing

about contact between the work and the lap and also of shifting the work lengthwise of the lathe. This latter is just about as important—perhaps more so—than the former. It is upon it that an accurate, cylindrical surface within the work depends. The softness of the lead provides for the lap holding the emery particles. If the work requires very great accuracy, as well as the removal of tool marks and scratches, we may use copper instead of lead for the lap. Of course, the rotation of the lap may be secured by using a dog or other device. Previous cautions as to counterbalancing should be kept in mind.

If the internal polishing is required for a short length of cylindrical surface, we may at times, use still another procedure. We prepare a suitable lap on a short bar and then secure the bar in the lathe chuck. The compound rest may now be used to secure contact. By shifting the carriage lengthwise of the lathe, we will get the necessary longitudinal movement.

It may be gathered from the foregoing that polishing is carried on in a little different manner, if the work as machined is somewhat rough. It may be advisable then to point out or emphasize, at this juncture, certain matters relating to finishing. The approved method of making the cuts on a lathe is to make the roughing cuts heavy and leave but little material to be taken off with the finishing tools. I am speaking now of cutting off metal with the cutting tools. It is advised to rough over the whole surface before beginning with the finishing of any part of it. The reason here is concerned with the results of taking off the hard exterior skin. The methods employed in making rods and bars has the effect, probably in most cases and with most metals, to produce an exterior layer harder than the body of the metal. This may have been produced by rolling, drawing or some other mechanical process. With some materials, the heating and cooling, incidental to certain procedures, may leave a hard skin. Cast iron, for example, is rather notorious for its hard outside layer, although this may be in part due to activities set up by the materials in the mold. We need not, however, concern ourselves especially with the *why* of a hard skin—the fact that it often occurs is the main point. Now when this hard skin is removed, there is probably more or less of a movement of

the particles on and near the new surface. That is, a re-arrangement of stresses take place. Consequently, if we take the finishing cuts at one point while the roughing near by is still undone, we need not be surprised

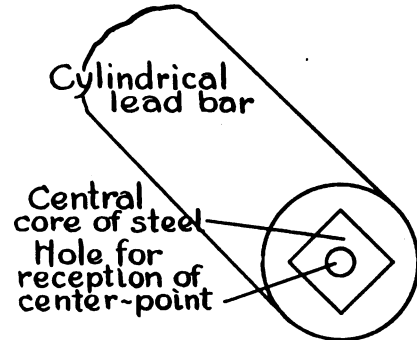

FIG. 4—A LEAD LAP FOR SMOOTHING THE INSIDE OF A PIECE OF WORK

if more or less distortion takes place in the adjacent machine-finished region. Let us pay attention then when we are advised to complete the roughing of a surface before we start in on any part of it to do the finishing cutting.

Cast iron, cast steel, brass and gun-metal are turned dry; forged steel, wrought steel, copper, and lead, are lubricated with soapy water. If the finishing cuts are slight and the proper tools are rightly used, ordinarily the work will have a smooth appearance after it is taken out and before any polishing is done. A perfect tool should leave the work accurate and smooth. However, it will sometimes happen—wherever the fault may be—that the work will have inaccuracies and will not have the proper smoothness. It is then up to the operator to remedy these defects. Sometimes, but only sometimes, it will be reasonably possible to do this in connection with the polishing. But at other times, more metal will have to come off than it is convenient to remove with an emery cloth; or perhaps it may not be possible to handle the cloth with the necessary accuracy to take off *here* but not to take off any more *there*. And yet the amount of metal that has to be gotten off may be too slight to deal with very satisfactorily with the ordinary cutting tools used for finishing. In such circumstances, the *file* is often a suitable tool to use. Files come in all degrees of fineness and coarseness, so that we may cut off little or much, as the case requires. Besides, a file may be handled with some degree of accuracy.



When the file is used on lathe work, it is proper to proceed much in the same way as if the work were quiet and held in a vise. But there are differences. We *hold* the file in our hands in about the same way. But the grasp of the hands is different for heavy and for light cutting, and the tool is held slightly diagonally. It is not simply held

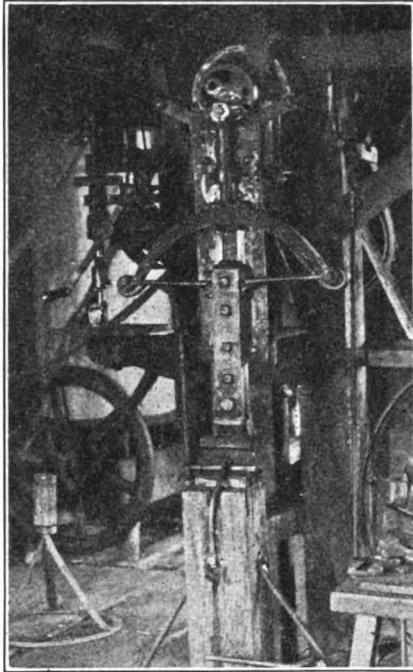

A COMPARISON—A USEFUL POWER HAMMER FOR A SMALL BLACKSMITH SHOP

upon the work, but is thrust forward slowly—slower than in vise filing—the revolution of the work insuring rapidity of cutting. During the backward strokes of the file, the pressure is simply relieved, or the tool is lifted just free of the work, the pressure being put on again during the forward stroke. The finer files may also follow the coarser ones.

There is still another mode of polishing. I refer to the procedure known as *buffing*. It is ordinarily resorted to where an exceedingly brilliant polish or lustre is sought. There may be a slight loss of the accuracy of the work consequent upon carrying it out; but there are multitudes of cases where this is a matter of no moment at all. As the method may be carried out on a lathe with rather less rotational speed of the lathe spindle than with ordinary polishing, it may seem preferable to many. The polishing or buffing agent is a *wheel* or *belt* to which emery powder has been secured by gluing. Or, where the

polish is to be very fine indeed, emery flour, crocus, rouge or the like may be employed instead of ordinary emery powder. The reason that a less rotational speed may be required of the spindle turns on the consideration that we are at liberty to use good sized wheels in buffing and good sized pulleys for the belts. When the work itself is rotated, we have to be content with the diameters it possesses. In buffing, however, the work is brought up against the wheel or the belt; so that all we have to provide is a *surface speed* of the right rapidity. The bigger the wheel, the rotational speed of the spindle remaining the same, the faster will be the surface speed. Likewise with the belt—if the pulley which drives the belt is big, the *rotational speed* of the shaft will not need to be so great.

We may without a great deal of trouble or expense provide for a rotational speed of the lathe spindle amounting to 2500 or 3000 rotations per minute. Assume that we have a line shaft rotating at 150 r.p.m. By using a 2½-foot pulley on the line shaft and a 6-inch pulley on the countershaft, we may give the countershaft a rotational speed something like 750 r. p. m. (It would be full 750 r. p. m., if we did not have to allow for slippage). Then by using a pulley on the countershaft with a diameter 4 times that of the smallest step on the cone pulley on the lathe, we will succeed in getting something like 3000 r. p. m. out of the lathe spindle—that is, if we do not have too much slippage. At any rate, call the speed 2500 r. p. m. Suppose now we rig a buffing wheel of

suitable size on a shaft, provide the shaft with suitable end depressions to enable us to mount it between the lathe centers, and square one end of the shaft to enable it to be driven by a dog or by dogs—suppose we do these few things. We are now ready to go ahead with buffing.

## A Spring Circular

From the Boston Work-Horse Relief Association comes this timely bulletin for distribution in agricultural districts. The Secretary, Mr. Lewis A. Armistead, at 15 Beacon Street, Boston, Mass., will gladly send gratis to blacksmiths as many of these circulars as are wanted.

It would be a splendid thing for a number of our readers, who are really interested in seeing that the horse is well treated, to secure a few and pass them out to customers.

A reprint of the circular follows:

1. Do not fail to provide clean, warm quarters in which your cows, ewes and mares can bring forth their young in early spring. Navel ill comes from dirt.

2. It is dangerous to expose young stock, especially foals and colts, to spring rain-storms. A day's exposure, if not fatal, may stop a month's growth.

3. It is bad policy to turn the stock to pasture before the grass has well started,—bad for the pasture and bad for the stock.

4. A gradual change from hay to grass is best; but, if you are bound to make the change at once, turn the stock out at night, instead of in the morning. Then they will feed



A COMPARISON—ONE OF THE MIGHTY POWER HAMMERS IN A MODERN STEEL MILL



through the night, and not lie down until the sun has warmed the air and the ground.

5. Get your horses into condition for the hard spring work,—the young horses especially. Many a colt has been ruined by being put to hard work without preparation. It is the same with green horses.

6. Look out for sore shoulders and backs, especially when plowing begins. Be sure that your collars fit. A collar too big is as bad as one too small. If the collar rides up, use a martingale, or a girth running from trace to trace, back of the forelegs.

7. When the horses are at work on a warm day, lift up the collars now and then, to cool their shoulders, and wipe off the sweat and dirt with your hand or a bunch of grass.

8. Sponge off the harness marks carefully when you stop work at noon and at night, and clean the inside of the harness, the collars especially. The salt sweat, drying on the skin and on the harness, is what makes the trouble.

9. If the skin is wrinkled under the collar or saddle, bathe it with witch hazel. If the skin is broken, bathe it with clean warm water containing a little salt. Fix the collar, with padding or otherwise, so that it will not touch the sore spot the next day. A little carelessness at the beginning may cause a lot of trouble to you and suffering to the horse.

10. Clean your horses at night, give them a good bed, and water them after they have eaten their hay. Let them rest an hour before they are grained. The observance of these simple rules will not cost you a cent, and will make the difference between a horse in good spirits and a lifeless one.

### What's the Circumference?

N. G. NEAR

**B**OTH the blacksmith who "hates figures" and the busy knight of the forge, who may revel in them but has little time to bother about them, will find this handy chart a relief in figuring circles; that is, in quickly calculating the circumference when the diameter is known, or vice versa.

Let us say, for example, that you want to weld a ring 20 inches in diameter. How much stock must be cut to avoid waste, or the danger of not cutting off enough?

Our easy chart will give you the answer in a jiffy—and accurately too. Just look for 20 in column A, which represents your known diam-

eter and glance directly across to column B. Here you will find the circumference desired to be 62

inches. And the circumference in this case is equal to the length of the stock needed.

Now to work it the other way round: we'll say that you have a piece of stock 80 inches long and you would like to know what diameter of ring it would make. Find 80 in column B and this time glance across to the left where you'll find your answer in column A as 26 inches—the diameter of the ring.

An ingenious blacksmith will find many uses for this chart where he is dealing with circles, and for the average run of shop work it will prove invaluable. Don't try to use it though for fine machine work where calipers are needed and figures run into hundredths of an inch.

You will find the range of this chart very wide, considering its small size. Calculations may be made from diameters of 1 inch up to one thousand inches, or in other units, if desired. For instance, feet, yards, or miles. The relative values of the figures in column A to those in column B are unchanging so long as the same units are used in both columns at the same time. By that I mean, do not try to figure feet in column A and inches in column B; use inches in both A and B, or feet, or any other unit of measurement.

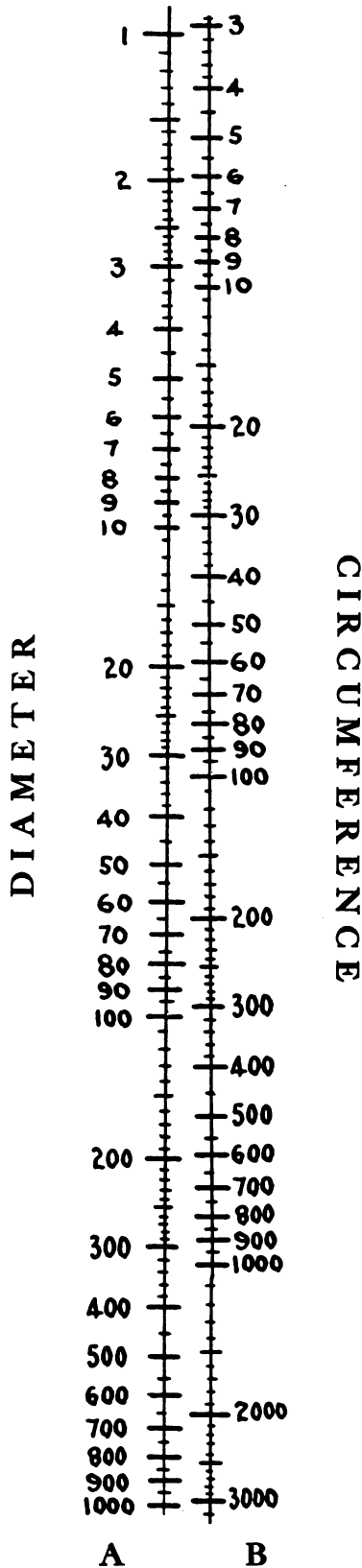

A HANDY CHART WHICH ENABLES THE BUSY SMITH TO FIGURE DIAMETERS AND CIRCUMFERENCES

### The Blacksmith, an Important Factor in the Industry of Japan

An interesting report comes to us, which points out how Japan's commercial rise is even more significant than her development as a military power, and in which the Japanese blacksmith plays no small part.

Whether there will ever be a military clash between Japan and the United States is open to question, but there is no doubt about commercial competition. Against our intelligence and ingenuity Japan places initiative and aggressiveness and a scale of wages and a standard of living before which the American worker must throw up his hands. For 2,577 years the Japanese government has been installing habits of economy into the people. Government reports of daily wages in Japan in 1915 and in New York in 1914 give this comparison:

	Japan	New York
Bricklayers .....	40c	\$6.00
Carpenters ..	21c to 35c	\$6.00
Blacksmiths ..	35c	\$4.00
Printers ..	17c	\$4.25



## Benton's Recipe Book

A good brass-polishing compound, that can easily be made up in the shop, is wanted by a Louisiana reader. After looking through the recipe book, I would suggest one of the following — choose that one which requires materials best obtainable in your vicinity:

No. 1. Sift coal ashes fine and mix with kerosene oil to a thick paste; add as much air-slaked lime as can be conveniently mixed with it. Apply this polish to the bright parts, rubbing hard; wipe off and polish with dry shaken lime.

Whiting and ammonia mixed to a paste is another good polish for brass. Apply and rub dry.

This is especially recommended for cleaning hot brass cylinder heads and jackets.

No. 2. Add together and mix thoroughly, 100 parts of powdered pumice stone, 2 parts oil of turpentine, 12 parts soft soap and 12 parts of fat oil or lard. When thoroughly mixed, add the mixture to a solution of 3 parts oxalic acid dissolved in 40 parts of hot water. Stir well until a uniform paste is formed. Apply to surface of any article of brass, by means of a cloth, rubbing it in well. Remove remnant and polish with a clean, dry cloth.

No. 3. To 2 quarts of rainwater add 3 ounces of powdered rotten stone, 2 ounces of pumice stone and 4 ounces oxalic acid. Mix thoroughly together and let it stand a day or two before using. Shake it before using and after application polish the brass with a dry woolen cloth or chamois skin.

A metal dough for stopping small leaks, plugging blow holes, etc., will be a welcome addition to the shop "Medicine chest." Try this one, which will prove its usefulness in dozens of cases where cracks and holes of minor importance need repair, or where you find them difficult to get at or cannot be soldered: take zinc 66 parts, tin 44 parts, and sufficient mercury to make a stiff dough. The zinc and tin are to be melted together and afterward granulated. The latter may be done by slowly pouring the melted mixture through a strong stream of water from a hose nozzle; or the filings may be used. The filings or granules are kneaded until an amalgam of the consistency of stiff dough is formed with the mercury. Excess of mercury should be squeezed out. The plastic mass is then forced into the opening and allowed to harden for an hour or two. It can then be filed and scraped like the metal itself. Only as much amalgam should be mixed as is required for immediate use.

To prevent hot lead from sticking to the pot or the tools heated in it, bothers one of our Western friends. A good solution for this problem is a mixture made up of

powdered charcoal, 1 quart; salt,  $\frac{1}{2}$  pint; yellow prussiate of potash, 1 gill; and cyanide of potassium a lump the size of a walnut. This may be coated over the parts to which the lead sticks.

To cool tool steel without hardening it, puzzles a young Michigan smith. You older, horny-handed sons of toil know of a hundred different ways, so skip this. But for the benefit of our Michigan reader Benton suggests this simple way:

Lay the piece on the floor behind the forge and you will be able to handle it in fifteen minutes. When the piece is wanted for immediate use, however, it can be cooled quickly by plunging it into a pail of soapy water. When this practice is followed the steel will be soft enough to cut with a tool.

The following iron cement, if properly prepared and applied, will unite broken iron parts very strongly, and may be found useful oftentimes for repairing broken machine parts of comparative unimportance. Mix equal parts of sulphur and white lead with about one-sixth part of borax and incorporate the three together thoroughly. When ready to use the mixture wet it with strong sulphuric acid and spread a thin layer of the cement on the joint to be united. Clamp together for five days when the joint should be dry and sound.



## Queries— Answers— Notes

**What's the Best Way to Make a Bar Shoe?**—Will some of the practical brother smiths give through these columns, with illustrations, their way of making a bar shoe? Also state proper bearing place on frog, the feet it is best adapted to, etc.

I feel there is an easier way of turning said shoe than I now use.

E. W., New Jersey.

**Cleaning Scale Deposits in Radiator**—In reading an article in the June, 1915, number under the "Auto Repairman," I saw a recipe for removing acid from radiators—namely hydrochloric acid. Now will you please inform me if this is all right for an old car which has never been cleaned before? I am wondering if the acid was taken out, if it might weaken the material of which the radiator is made, similar to a tea kettle which, as you know collects acid from the water and forms scale which if entirely removed makes the kettle so thin as to be almost useless. Also tell me how long the acid must remain in engine in order to cut accumulations out and if the engine should be left stationary all the time.

I am also in a quandary as to a large 400-gallon gasoline tank. It leaks at the

pump connection which was soldered on. Now I thought this could be repaired with a gland and some kind of packing. The doubtful thing is what kind of packing or gasket to use to hold gasoline. This connection is in the end of tank and we wish to do away with it and place it on the top of tank. The tank is made of thin galvanized iron and steel.

WM. DAVIS, Ontario, Canada.

**In Reply**—Acid should always be used with caution in cleaning out an automobile radiator. If used at all, be careful to avoid spilling any on the rubber hose connections, or wood work, or the hands; and circulate through the system (by running the engine) for about five minutes, then draining. It may be used over and over again, as the strength is little diminished by one cleaning. However, it should be strained before re-using.

Perhaps a better, and more satisfactory method, because of there being less personal risk attending to its use, is the lye process. This is done as follows:

Dissolve a half pound of lye in about five gallons of water. Strain the liquid through a cloth and put in the radiator. Run the motor for five minutes, then draw off the cleaning mixture. Fill with clean water and run the motor again; remove the liquid once more, and finally refill the cleaned cooling system. Ordinary baking soda can also be used, by mixing  $\frac{1}{2}$  lb. to 4 gallons of water. It is best to dissolve the soda in warm water before pouring it into the radiator, otherwise the crystals drop to the bottom. If the cooling system seems to be very dirty as far as scale goes, it would be very wise to run the soda solution through it several times in order that all of the scale will be taken out.

You should be quite sure that the radiator shell is not too thin, for as you say, when the supporting wall of scale is removed from a thin wall, it is liable to be weakened.

Concerning the repair to the gasoline tank you might try a packing made up of the commercial cotton variety, into which you have rubbed a quantity of soap. This will not be affected by the gasoline.

S. S., New York.

**For the Treatment of "Seedy-toe"**—During the year 1916 I had over 35 mules brought to my shop with hollow feet, usually known as sand gravel. The disease generally begins in the toe and eats its way to the top of the foot to the edge of the hair. All the tissue between the hoof and sole of the foot becomes dry and mealy-like and comes out and leaves it hollow, and the mule becomes very lame. Out of the 35 or 40 cases I have had in one the disease started up in the foot and ate its way out to the toe. Have never seen a horse with this disease.

I want to know what the disease is and the cause and treatment.

My way of treating this disease has been to get out all the loose stuff by using a probe and washing out with a sponge and packing with some good hoof ointment and cotton, and finally shoeing. And in some cases, where the animal is very lame, I cut off the horny part of the hoof, up about as high as the hollow goes. This usually stops him from limping, and if properly cared for by the owner and a shoe kept on, will grow out in 9 to 13 months and be solid.

E. M. SMITH, North Carolina.

**In Reply**—From your description of the conditions, we judge that this disease is the one popularly known as "seedy-toe."



The hollow-wall condition is usually found in the toe of the foot and may extend all the way from one inch up into the foot, at the toe, too as far as the coronary band. In some cases the cavity of the toe may be just a small one, perhaps large enough to admit the end of a No. 10 nail. In other cases the cavity may be large enough to easily admit one or two fingers of the hand.

The treatment usually recommended for this condition is to cut away all of the loose or separated horn, paring it carefully and thoroughly until nothing but the firmly attached horn remains on the foot. The bared surface is then carefully cleaned and all dead and diseased tissue carefully removed.

When the hoof is thus cleaned up, supply a liberal dressing of beef tallow, thoroughly and carefully bandaging the bare foot and protecting it as far as possible with a piece of tin or sheet brass, carefully cut to fit over the bandaged portion of the foot. This dressing and treatment should be repeated at frequent intervals, cutting away any diseased tissues that may appear from time to time and allowing nothing but good, healthy horn to grow over the bare portion of the foot.

S. S., New York.

**Wants to Know How to Make Home-made Batteries**—I saw a recipe in a back number for making wet batteries. Will you please publish it again? And tell me where I can get the necessary carbons?

I tried the local gas house here and they said they had carbon only in powdered form but that it might be hardened for use in batteries. W. W. LEE, Florida.

**In Reply**—First, secure a porous cup of some description, about six inches high and two or three in diameter. This is made of unglazed earthenware; but if none is obtainable, a long, narrow flower-pot with the hole plugged up will do. Carbon in sticks may be purchased from any electrical supply house. Cut it to fit the cup or flower-pot easily and to project two inches above. It should be twice as wide as it is thick.

Now, dip the end of the carbon into melted paraffine and keep it there for an hour. The paraffine is kept melted by placing the vessel containing it in boiling water. Next, after cooling, drill two-quarter-inch holes through the paraffined end, 3/4-inch from the top. This is to hold a lead cap which we now make. Take a block of wood 1/4-inch wider and thicker than the carbon. Tack a copper wire on the block and then wrap a strip of heavy, thick paper around it to project 1 1/4-inch above as shown. Pour melted lead carefully into this box until half full and then press the paraffined end of the carbon into this lead until it rests on the bottom. The lead will run into the holes and hold it firmly. Allow to cool.

Place this carbon in the flower-pot and pack firmly with chloride of lime or bleaching powder. Next, cut a piece of sheet zinc as wide as the flower-pot is high and long enough to roll around, but not to touch the pot. Solder a wire to the top. Take a glass jar and place in it the flower-pot with the zinc surrounding it.

Put about 4 ounces of common salt in the bottom, and add water till three-quarters full, also pour a little water in the flower-pot. You now have a modified Leclanche cell, considered one of the best primary batteries. Once in six months add more salt and occasionally more water.

S. S., New York.

**A Criticism**—In the January issue (Page 100) I notice a calculation of stock for pipe hangers, which I believe is incorrect. The correct, entire length of stock needed to make pipe hangers to the dimensions required, would be 62 inches instead of 57 inches.

I obtain my figures as follows: (sizes and dimensions as shown in accompanying diagram) First, we divide the hanger into three parts; the half circle at the top, the straight reins, and the two eyes at the end.

Next we take the inside diameter of the half circle, which is 5 inches, and add to this 1 inch, the thickness of the stock; this sum times 3.1 gives us the stock needed for a full circle, so we divide it by two, and the result—9.3 or approximately 9 1/2 inches is the length of stock needed for our first part.

The reins would each be 20 inches long—being simply the measurement on each side from the half circle to the beginning of the bend for the eyes on the ends of the reins.

The mistake to which I have reference is that this length was incorrectly calculated. It should be 20 inches instead of 17 1/2 inches, as published.

The stock for the eyes is calculated the same as the calculation for the half circle, but the figures are not divided by two.

As the eyes were not to be welded in this case no extra stock at this point need be figured.

**Is Tungsten Steel, High-Speed Steel?**—Please settle an argument between me and a friend of mine. Would it be proper to use the words, Tungsten Steel, when speaking of High Speed Steel in all cases around the shop or even when talking to salesmen? P. H. TYNAN, Virginia.

**In Reply**—With reference to the matter of High Speed Steel and Tungsten Steel, we would say that in order to reply to your question, it will be necessary to understand that the high speed steels of the present day are combinations of iron and carbon with tungsten molybdenum and chromium. Generally speaking, therefore, a high speed steel may also be a tungsten steel. However, the class of steels known as "High Speed" is that group of steels which retain their cutting edge when extremely high speeds are employed in the cutting operation. On the other hand, the word, tungsten, when used in connection with steel, refers to the elements added to the steel in order to increase its cutting efficiency. The percentage of tungsten added to the steel may be all the way from 9 per cent. to 16 per cent. or more. Of course, it is possible for a high speed steel to contain a little or no tungsten, although the greater proportion of the high speed steels on the market today contain the tungsten element in a greater or lesser degree.

We would therefore judge that the words, tungsten and high speed steel, cannot be used indiscriminately and that while a tungsten steel is a high speed steel, all high speed steels are not tungsten steels. S. S., New York

**More About Browning Gun Barrels**—I tried the formula in the March AMERICAN BLACKSMITH for blueing gun barrels and find that it don't do the work. I let it dry and when I washed it it all came off. Can you tell me how they blue them at the factory?

J. A. FRISK, Janesville, Minn.

**In Reply**—We are inclined to believe that the ingredients which you used for this purpose were not of the proper

strength. This formula came to us from a reliable source, and we are quite sure it will work if chemicals of proper strength and freshness are employed.

We are glad, however, to give you another formula for the blueing of gun barrels, and suggest that you try this, first

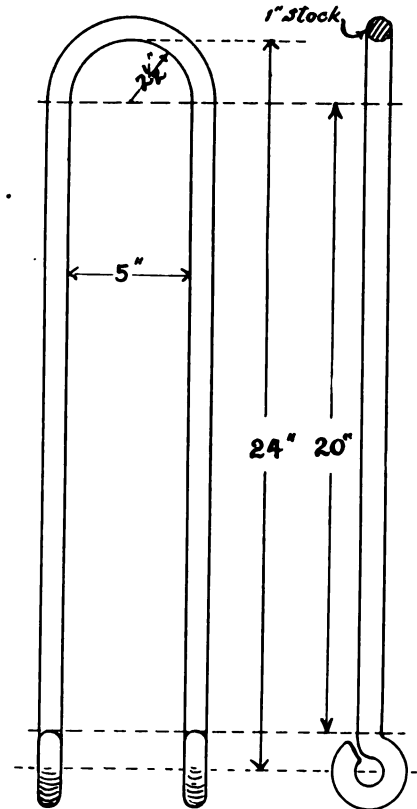

**MR. OST'S CORRECTION: THE RIGHT WAY TO FIGURE STOCK FOR PIPE HANGERS**

making certain to secure ingredients of proper strength and freshness. This formula is as follows:

To blue gun-barrels, etc., dissolve 2 parts of crystallized chloride of iron; 2 parts solid chloride of antimony; 1 part gallic acid in 4 or 5 parts of water; apply with a small sponge and let dry in the air. Repeat this two or three times, then wash with water and dry. Rub with boiled linseed oil to deepen the shade. Repeat this until satisfied with the result.

The methods of blueing barrels in the gun factory is of course usually considered a secret process. However, the following is the method probably used by the majority of gun manufacturers:

The blueing of gun barrels is effected by heating evenly in a muffle until the desired blue color is raised, the barrel being first made clean and bright with emery cloth, leaving no marks of grease or dirt upon the metal when the blueing takes place, and then allow to cool in the air. It requires considerable experience to obtain an even, clear blue.

The following is a reprint of the formula to which you had reference—that which was published in March:

The mixture is made up of one ounce of sulphate of copper, one ounce of sweet spirits of nitre, one pint of distilled water. Four coats are applied, allowing several hours to elapse between the successive coats; brushing after each if necessary.





After the last coat, rub down hard and allow to dry 24 hours. This gives a reddish-brown color without gloss. By adding arsenic to the mixture before the last coat, a deeper hue is obtained. The polish is obtained by means of a mixture of boiled oil, beeswax and turpentine, comparatively thick. Rub in well with cotton cloth and finally with the palm of the hand. Thinking that you may possibly be interested in a formula for blueing gun barrels, we are also glad to give you this: Dissolve 2 parts of crystallized chloride of iron; 2 parts solid chloride of antimony; 1 part of gallic acid in 4 or 5 parts of water; apply with a small sponge, and let dry in the air. Repeat this two or three times, then wash with water and dry. Rub with boiled linseed oil to deepen the shade. Repeat this until satisfied with the result.

S. S., New York.



## The Automobile Repairman

### Using Common "Sense" Methods in Curing Auto Troubles—3

C. L. WHITE

#### Troubles We Feel and Smell

Those of our readers who have been following in detail our previous articles on this subject will recall the statement that the success of this method lies in practice, and then—in more practice. We cannot emphasize this point too strongly; for the mere reading of these articles will accomplish little, unless the principles contained therein are actually put into practice.

It would be a good thing for the reader to carefully review the first and second installments before taking up this, paying particular attention to the four steps suggested, on page 160 of the April issue, for learning to develop the senses for locating automobile troubles.

In the foregoing articles we have considered the most common of the troubles we see and those we hear. We will next deal briefly with the comparatively few Troubles We Feel.

#### AT STEERING WHEEL:

1. *Pounding or laboring.* This may be caused by a hot engine, due to lack of oil, poor lubricating oil, lack of water in radiator, fan belt broken, or possibly from trying to climb too steep a hill or negotiate deep sand, mud, or snow on too high a gear.

The remedy has already been specified, or is too obvious to mention.

2. *Grinding or trembling.* This may be attributed to a number of causes—a flat tire, a loose front wheel bearing, or even due to the bevel drive gears becoming badly worn or in poor adjustment. In this latter case the grinding may often be felt through the wheel.

3. *Play in steering gear and connection.* This allows looseness at the wheel. Careful inspection while the wheel is being moved by an assistant will usually disclose the point of greatest wear, thus permitting re-adjustment or refitting or in some cases entire replacement of these parts. Very frequently a disagreeable looseness is occasioned by worn bushings in the steering knuckles or rod ends.

#### AT THE PEDALS:

1. A *broken clutch spring.* This will be immediately felt for the reason that little, if any, pressure is needed to disengage the clutch.

2. A "*gripping*" clutch should be given very prompt attention. If allowed to continue to jerk the car when starting it will quickly and effectively twist off axle shafts, shear keys, demolish differential gear housings and unnecessarily wear out the rear tires. This "*gripping*" clutch may be caused by a badly worn leather-faced cone clutch, or lack of lubricant Neat's foot oil on the leather; improper lubricant being used on a running-in-oil multiple disc clutch (usually too light an oil) a gummy clutch (needs cleaning), or a clutch having unequal pressures at different places on the clutch face. This last occurs on clutches having more than one spring or having a single spring and three or four adjustable dogs which transmit the spring pressure to the disc surfaces. A "*pry*" test should be made with a screw driver at each spring or dog to determine whether these pressures are practically uniform.

3. *Brakes not holding or frozen* can, of course, be most quickly felt at the brake pedal. Next to the steering gear it is essential that the brakes be in working order.

4. *The feet on the pedals* can

greatly assist the hands on the steering wheel in detecting the presence of unusual grinding, pounding or other troubles that can be felt.

#### WHEN CRANKING ENGINE :

1. *Poor compression* due to leaky valves, piston rings, gaskets, spark plugs, etc.

2. *Bearings in Engine too tight.* Many mechanics make the mistake of tightening a properly fitted bearing too much. If the bearing has been properly "*flued in*" and tapped after tightening, its degree of tightness should not hold up the weight of the piston and rod when tipped over 15 degrees or so from the vertical. If the bearing is too tight, especially an old bearing there will not be sufficient space for the lubricant and the result will be heating and soon another loose bearing to be taken up all over again. In the case of an engine having a new set of bearings throughout, the bearings may be drawn up somewhat tighter, providing the engine can be run under *other* power for a few hours until the lubricant has been well worked into the bearings.

3. *Bearings in Engine very loose* can be sometimes felt when cranking the engine by hand.

#### BY PLACING HAND ON THE PART:

1. *Hot radiator.*
2. *Cool cylinder* due to misfiring.
3. *Unusual vibration.*
4. *Hot brake drums* which may be caused by "*dragging*" brake bands.
5. *Gasoline Leaks* by feeling along the pipes.
6. *Loose bolts, nuts, parts, wires, etc.*

#### FELT BY BODY:

1. *Car jerks*—due to clutch needing attention.

2. *Car lists or lurches*—due to flat tire or broken spring.

3. *Car has tendency to skid* when stopping—due to the fact that one brake is tighter than the other. The brakes should be adjusted so that the rear wheels stop simultaneously when brakes are applied.

There is little we can say about the fourth and last subdivision of this "*sense*" method relating to the except to mention the most common varieties. These follow:

1. *Rich mixture in carburetor* causing smell of unburned gasoline in exhaust.

2. *Too much oil in the engine* causing bluish-white smoke at the exhaust.

3. *Hot engine* due to lack of oil or hot water causing a smell like that of burning paint.



4. *Gasoline leaks*, of course, can be detected most often by smell.
5. *Leaking prestolite gas*—if such is used.
6. *Kerosene lamp smoking*, if used.
7. *Clutch leather burning* due to slipping.
8. *Wire insulation burning* due to hot engine or a leak through the wire insulation or fibre in distributor blocks.

## Gas Engine Operation Made Simple—9

The Purchase, Installation, Operation and Troubles of a Gas Engine.

J. L. HOBBS

### Batteries and Magnetos

We will now take up the different kinds of batteries and magnetos used for ignition purposes and leave the discussion on wiring until the end, as the wiring is practically the same for all systems of ignition.

There are three kinds of batteries used for ignition purposes, all three giving splendid service where they are at all adapted to the work they are to be used for, viz: dry cells, wet cells, and storage batteries.

Dry cells are properly named as far as outside appearances are concerned, there being no moisture of any kind visible. They can be used in any position, on their side or on either end, although it is claimed they will last longer when used in an upright position; that is, with the binding posts on the top. These cells consist of an outside shell made of sheet zinc, made in any form or shape to fit the place in which they are to be used. In the center is a carbon post which runs almost to the bottom of the zinc shell. Around this carbon or center post is packed the chemicals which are to furnish the electricity. The top for about half an inch is sealed over with sealing wax or tar, or anything that will seal it tight and prevent moisture either entering or escaping from the zinc cylinder. The current is produced by the chemicals within destroying the zinc on its inside surface. These batteries have wonderful recuperative powers; for instance, when you stop your engine in the evening the batteries may be almost lifeless, yet in the morning be good for another day and be used from day to day after they are thought to be almost worthless. Dry batteries will last longer when used a little each day than when allowed to stand without use. In fact they will deteriorate while stocked in a

store almost as rapidly as when in use. For this reason you should require batteries tested at the time of purchase. This test can be made by a simple instrument commonly call-

The copper will also be destroyed in time, but not so rapidly.

If you have a clean dry place in a basement where the water in these cells will not freeze, and where you

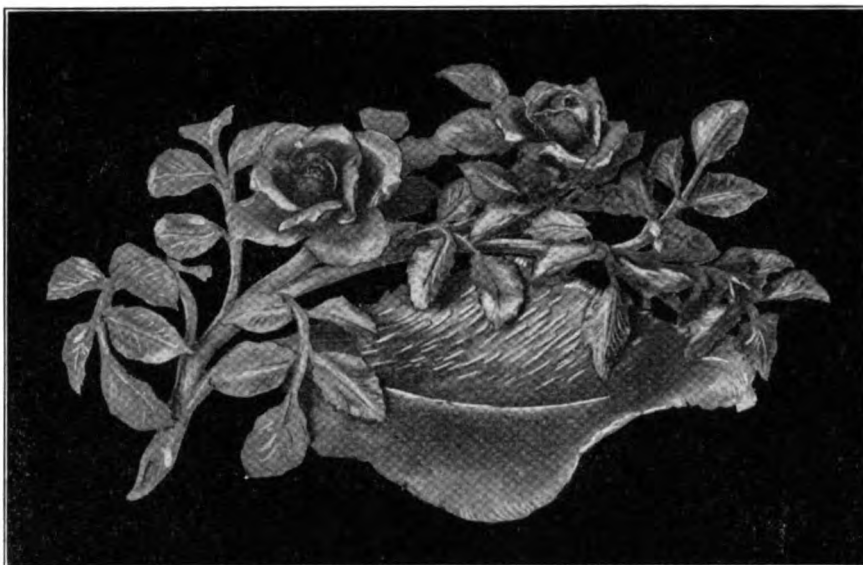

ANOTHER FINE EXAMPLE OF MR. CRAN'S MASTER-CHAFTSMANSHIP AT THE FORGE

ed a battery tester, the scientific name of which is an ammeter, or a combination of ammeter and voltmeter. The merchant will know what you mean if you tell him you want a battery tester. A dry cell which is perfectly dead may be revived for temporary use by drilling two or three holes through the shell on top and pouring into these holes as much vinegar as will soak in. The holes should again be sealed with sealing wax and a wire passed from one binding post to the other for a couple of minutes when your battery will show temporary life. This is only resorted to as an expedient, but is not profitable but will help out an emergency at times.

Wet cells are such as are commonly used by any telegraph operator, who will be glad to explain them and assist you in the proper construction of a wet battery. It may consist of from one to any number of cells, according to the strength of current desired. This type of battery consists of a glass or glazed earthen jar, which will hold about a gallon of water. Into it is inserted a zinc and a copper post, which can be purchased from any electric supply store, in the shape of a crow's foot. The chemicals consist principally of rain water and blue vitriol. A little salammoniac is also used. The electricity in this battery is also produced by the destruction of the zinc by the chemicals.

can get at the cells occasionally for the renewal of the water, chemicals, and crow feet, you will have a battery which will give you good service and at a minimum cost. It is necessary to attach a wire from one binding post to the other, short circuit it as we call it, to start it working properly and quickly.

The storage battery is coming into common use now for ignition purposes and is very reliable when understood, and where means are at hand for recharging. The recharging of these batteries is rather a delicate proposition and would require too lengthy an explanation for this article. Besides every storage battery goes out with a book of instructions and the man who charges it for you will give you all the information you may desire concerning them.

The current from an electric lighting system is sometimes used for ignition purposes, and works nicely and is very economical after being installed, but is rather expensive to install on account of the attachments necessary to use this current safely.

The magneto is coming into its own very rapidly for ignition purposes, especially since self starters are in general use on heavy engines, which will give them speed enough to cause the magneto to give a spark of sufficient intensity to start the engine. There are numerous different types and makes of magnetos, but we will deal only with the various



types in reference to their construction, such as direct current, alternating current, high tension, low tension, and the non-rotating magnetos.

Magneto ignition has developed wonderfully during the past ten years. There was a time not long ago when a magneto for ignition purpose was a curiosity, but the engine not supplied with some kind of a magneto now is as much of a curiosity. The evolution of the magneto began with the old low tension direct current which required several hundred revolutions per minute in order to generate sufficient current for ignition purposes. With this type of magneto it was always necessary to have battery ignition to start the engine and get up the speed necessary to start the magneto to work. This magneto was later superseded by an alternating current magneto which did not have to run so fast and which gave better service on account of making a hotter spark. It was also found to be more economical. High tension magnetos were then developed which would work without the aid of a coil box, both of the older type requiring the use of a coil box to intensify the spark so it could be used for ignition purposes. These magnetos have been developed until they have been built which will run at the same speed of the engine and produce a sufficient spark at a very slow speed to start the engine, making it possible to do away with the batteries entirely for starting purposes.

A magneto is not hard to understand after making a careful examination of it and studying its construction. It consists of a set of magnets, an armature, some carbon brushes and a frame to support the different parts. It takes its name principally from the magnets which form the major part of its construction.

The winding of the armature has to do with the style and type of the magneto and also determines the kind of work it will perform. The armature, generally consists of some soft pieces of metal wound in such a way that when rotated between the magnets they will produce a current of electricity. The armature commonly used today produces the current at different places in its rotation between the magnets. The current is only produced at these particular places, so that the magnetos must be timed to the engine in such a way that the armature will be in one of these positions at the time

the igniter is tripped to make the spark, or when the timer of the spark plug system makes its contact to make the spark. These places can be very readily determined by holding the magneto in one hand and rotating the armature with the other. At these places will be noticed a resistance or tendency of the arma-

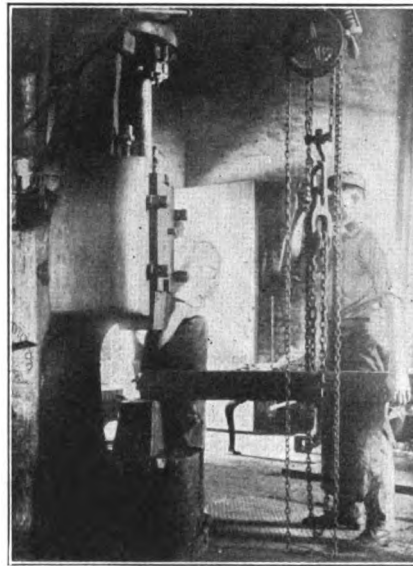

**THE POWER HAMMER HANDLES WITH EASE JOBS THAT WOULD ORDINARILY BE TURNED DOWN**

ture to rotate in the opposite direction to the way it is being turned. These are called the points of resistance.

The worst enemy of a magneto is surplus oil and dirt. These will cause short circuits. Oil is to be used on a magneto in the most sparing way possible, as ball bearings are generally used on the armature, which do not need but little oil. If too much oil is put on these bearings it will get on the commutator, brushes etc. and you will get no current. This can nearly always be remedied by washing the magneto thoroughly in gasoline or kerosene, but care must be taken to allow it to become thoroughly dry before attempting to use it again.

Most magnetos at present are gear driven. When removing this type of magneto from the engine, look for the markings on the gears. These are put there by the factory so it can be replaced to run in perfect time with the engine. If there are no markings, make some before removing so you will be sure to get the same teeth back together again. You will then have no trouble in removing and replacing the magneto. If you should however, remove it before looking for these marks and

after it is too late to find that there are no markings, you may get out of your difficulty in the following manner: Take the magneto in one hand and determine by rotation where the points of resistance are and mark them. Then set your engine so that the igniter has just tripped; then place your magneto on its resistance position and put it in mesh with the gears and you are right.

There are still quite a few friction drive magnetos in use so a few words about them and the method of placing them in position might be well mentioned here. The magneto should rest on a firm foundation with the friction wheel touching the fly wheel just hard enough to cause it to rotate at the proper speed to produce the spark. You will notice a little governor of some kind on the armature shaft which allows the friction wheel to slip when a certain speed is reached. This is to prevent the burning out of the armature. A magneto should never be fastened to a fly wheel so that it can not get away when the speed gets too high for it. If it is you will be in the market for a new magneto.

There is still another magneto which is so unique in its construction as to constitute a class by itself, which we will call the oscillating magneto. Its workings give it its name. It consists of a frame, magnets, armature, a wire to the stationary electrode and a finger on the end of the rotor, which corresponds to the armature of the other type of magnetos, to give it the little oscillating motion which is all the motion it needs. The strong points of this magneto are that it will give as hot a spark when the engine is barely moving as when it is running 500 revolutions per minute. It is also arranged so that it operates only when a spark is desired. It is operated by springs. The igniter rod rotates it as far as it is to go in one direction, when it slips off and the springs return it to the rest position, the movement by the spring producing the spark, so you can see that it will work just as quickly at slow as high speed. This magneto is very efficient in starting the engine and requires no batteries whatever. It is very durable, being injured only by over-lubricating and the wear in the bearings. Too much oil will short circuit it, and if the bearings wear until the rotor touches the magnets at any place this will also put it out of business. (To be Continued.)

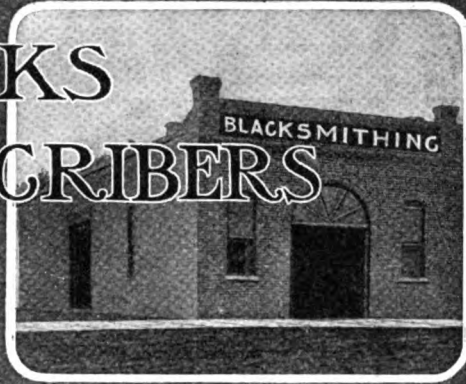

# TIMELY TALKS WITH OUR SUBSCRIBERS

The American Blacksmith is published monthly at The New Sidway Building, Buffalo, N. Y., U. S. A., by The American Blacksmith Company, Incorporated under New York State Laws. Entered, February 12, 1902, as second-class mail matter at Buffalo, N. Y., Act of Congress, March 3, 1879.

William F. Wendt, President      Albert W. Bayard, Secretary      Harry O. Mitchell, Editor  
Associates: James Cran      Bert Hillier      A. C. Gough      Dr. Jack Seiter

Subscription Price: \$1.00 per year in advance, prepaid to any postoffice in United States or Mexico. To Canada, \$1.25; other countries, 6 shillings. Reduced rates to clubs of five or more on application. See "Honor Roll" page for money-saving, long-time rates. Cable address, "Blacksmith," Buffalo. Lieber's Code used. Subscribers should notify us promptly of non-receipt of paper or change of address. In the latter case it is necessary that you give us both the old and the new address.

### BUSINESS AS USUAL—ONLY MORE SO

At the beginning of the war, "Business as usual" was the standard which the English people set up. Seven months of war and England was convinced that "Business as usual"—only more so, was needed to back up the man at the front.

It is encouraging to note how we in the United States are profiting by Britain's example; how we are quickly marshalling our military forces, organizing our tremendous agricultural and industrial resources and conserving our energies in all directions to stand back of Uncle Sam in the struggle to come.

A definite responsibility rests upon every man back at home to plug away to the best of his ability. The government and its fighting force are only as strong as the industries back of them, and it is up to you, Mr. Blacksmith, to "do your bit" behind the anvil and forge.

This is no time for slackening up, for setting a slower pace in business, for being fearful of what the future may bring forth. "Business as usual, only more so!" Let that be your slogan. Speak it, think it and act it, cheerfully and courageously as you go about your work, doing your best and satisfied that in so doing you will be working hand-in-hand with the boys at the front in helping to "make the world safe for Democracy."

### TWENTY YEARS AHEAD

Do you know, Mr. Reader, that one of "Our Journal" subscribers has paid his subscription in advance for twenty-years? Do you know that others of "Our Folks" have paid in advance for all the way from two to eighteen years? And then do you realize what those figures mean? Read the Honor Roll this month and think it over.

### Subscription Agents

When a stranger solicits your subscription to THE AMERICAN BLACKSMITH or any other publication, insist upon him showing you absolute proof that he is an agent in good standing and is employed by the publication which he represents. Don't under any circumstances, give the man your money if you are not sure that he really works for the paper he says he does. No matter what the man offers you—no matter what price he makes—no matter what premium he promises to send—Don't Give Him Your Money If You Are Not Sure.

### CONTENTS, JULY, 1917

On Guard for the Future—Frontispiece ..	236
A Western New York Auto Shop..	237
Stop the Leaks .....	240
A Progressive Nebraska Shop .....	241
Put The Power Hammer to Work—2	242
The Oxy-Acetylene Plant—5.....	244
Gas Engine Operation Made Simple—10 ..	245
The Smith in the Daily News .....	246
The Old Flag—Poem.....	247
Heats, Sparks, Welds .....	247
Shops From Many Lands .....	248-49
Our Honor Roll .....	250
The Machine and Tool Smith.....	251
Selecting the Lathe .....	251
Sturdy Knight of the Forge Stands on His Rights .....	254
Organize to Care for Army Animals	255
Character in Business .....	255
Benton's Recipe Book .....	256
Iron or Steel, Which? .....	256
Compounds for Welding .....	256
Queries, Answers, Notes .....	256
Likes the Articles on Autos.....	256
A Letter from Michigan .....	256
Mr. Murphree Tells of His Experience ..	256
A Plan for Mr. Bourgon's Quebec Shop ..	256
Mr. Erickson Describes His Shop	257
A Correction .....	257
Welding Pipe in a Tunnel .....	257
A Shop Plan for Mr. Lackenbauer	258
American Horses in the War .....	258
The Automobile Repairman .....	258
The Care of Tires—4 .....	258
Hot Weather Rules for Horses .....	259

### DON'T "CHINAFY" YOURSELF

In these days of modern conveniences and devices it is quite remarkable how the native population of the big Chinese cities manage to get along with primitive articles when on every hand can be obtained, at small cost, conveniences that would insure them a longer lease of life.

Although American and English hardware has been introduced and is being imported into China to the amount of millions of dollars in value every year, we still find the ancient Mongolian blacksmith hammering out his crude tools, kettles, weapons, razors, etc., by hand.

Imagine a Chinese razor—huge, clumsy, unwieldy—forged from a heavy American file! And compare this with the tool you use at home. Yet the former instrument of torture is the weapon that would probably greet your face were you to visit China today.

No doubt many generations will elapse—perhaps centuries, before the Chinese blacksmith will awaken to his opportunity in using modern manufactured articles, tools and machines. He will still go on, laboriously forging out his simple devices, while just around the corner he could purchase at a nominal price and of better quality, the self-same thing he spends days in making—or a machine that would make a hundred while he was shaping one.

Let's see—wasn't it T. R., that old war horse of Spanish-American War and White House fame, who once said: "Don't Chinify yourself?" Maybe he had the aforementioned antique specimen of the Chinese blacksmith in mind when he said that. Anyhow, it's worthwhile thinking about when we say to ourselves, "O, pahaw, what's the use of all these new-fangled contrivances anyway?"

Don't Chinify yourself—be a "progressive" in the smithing business. If you have not already looked into such things as oxy-acetylene welding, power-in-the-shop, labor-saving apparatus, wood-working machinery, vulcanizing equipment, calking devices, etc., better begin today, and really find out for yourself what an opportunity awaits you in the use of up-to-date shop equipment.

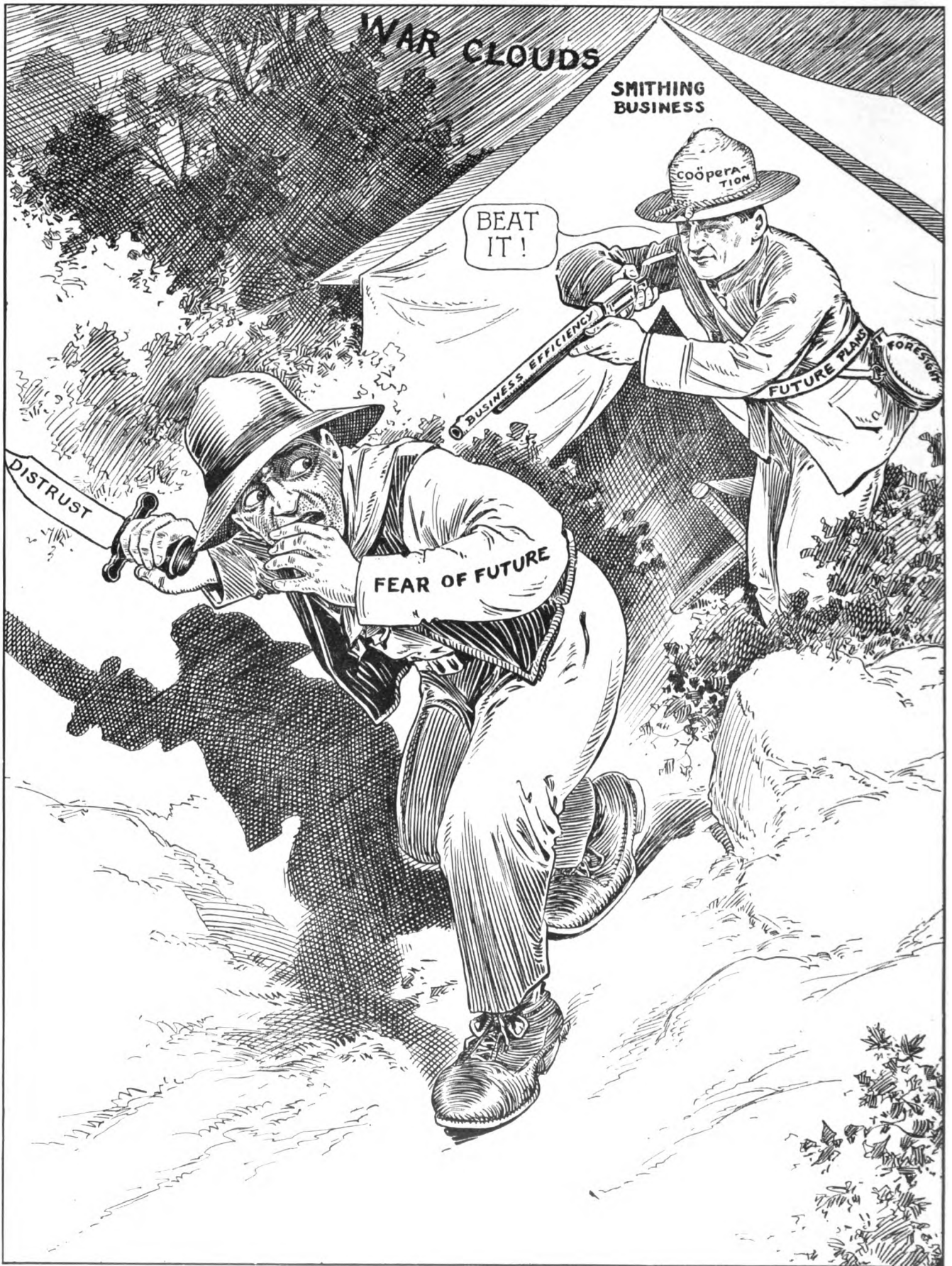

Apologies to Farm Imp. News

**ON GUARD FOR THE FUTURE**

If we believed all the talk we hear about what the war will do to business, we would soon think the world was coming to an end. No such thing. Of course business will not go along quite as smoothly as in times of peace; prices may be higher, business a little harder to get, it will be more difficult to obtain supplies; but don't, *don't* let fear and a cowardly anticipation of the future occupy your mind. Drive out the invader! Take a firm stand for the future. Resolve to do your part at home as valiantly as the boys in the trenches. Stand behind your country—be a Soldier of Industry, courageous, fearless, active, brave—working, planning; doing the best you can, and patiently bearing your burden of Uncle Sam's big load.



# A Western New York Auto Shop

## Describing the Equipment and Methods of the Y. M. C. A. Shop at Its Big Buffalo School

WHILE the Y. M. C. A. auto shop' was equipped for the express purpose of instructing students of the Association School, yet the arrangement of its equipment and the general shop layout, together with a description of some of its many handy appliances, will prove of interest and practical value to both the smith who contemplates taking up auto repairing and he who is already in the business.

Because of its location in a busy, down-town part of Buffalo, the first need was to economize in space. Land values in the midst of a big city prohibit the establishment of a one-story shop which sprawls over a considerable space. So a two-story building had to be selected, and one, substantially constructed of brick, was secured. The manner in which the school went ahead and arranged its machinery, etc., in spite of the many drawbacks in the building itself, reveals almost a genius for planning.

The structure was originally a big livery stable and later a wheelwrighting establishment, where, in addition, was carried on light forge work and a little machine shop practice. The first floor is now of concrete over all, and was planned to be used for general overhauling, washing and storage of cars; the upper floor to be arranged for the actual repairing of parts and to be thoroughly furnished with all necessary equipment for every branch of automobile repairing.

In order to facilitate the removal of heavy parts from the ground floor to the upstairs' shop, a heavy beam was rigged up over the door shown to the left of the accompanying shop diagram. To this is attached a powerful chain hoist, and it becomes a simple matter to remove a 6-cylinder motor or a chassis from below and swing it onto the shop floor. Here it is placed upon strong wooden horses and the boys "fall to" and clean 'er up or make such repairs or adjustments as are necessary. These handy little horses are about the most convenient things one could imagine around the auto shop. They are easily made as shown

in one of the working drawings which accompany this article.

The reader must understand that the shop accomodates outsiders as well as students; that is, if the owner or chauffeur of a car needs a general overhauling of his machine or repair of some part he may drop into the "Y" shop. Here the students are only too glad to welcome the opportunity of tackling what may prove to be a new problem to them—incidentally adding a mite to the school's funds with which to purchase new equipment. So besides giving the boys many a fine lesson in handling the tough propositions that find their way into the shop, the equipment had to be planned to accomodate these outside jobs. In this respect it is much like that of the professional shop.

The shop floor is arranged with all power machinery parallel with the two line shafts and as compactly placed as possible to save steps. The power unit is an Olin-Buffalo

facilitate easy shifting of the main drive belt from one unit to the other. An iron rail three feet high, and fitted with heavy woven wire, partly encloses the power plant and prevents any accident which might be caused by carelessness in brushing against some of the exposed parts of the high voltage motor or revolving parts of the gas engine.

There are three lathes which permit several jobs to be set up at one time and enables the boys to get out a hurry-up job in case of necessity without removing, perhaps, a heavy, partly-finished piece of work; which would be the case if only one lathe was provided in the shop equipment. Handy boxes are placed under each lathe bed to catch shavings and chips that may fall while turning. These boxes can be easily built after the fashion shown in the diagram.

In these days of high prices in metals, the economical machine and tool smith will take advantage of such devices to save every ounce of

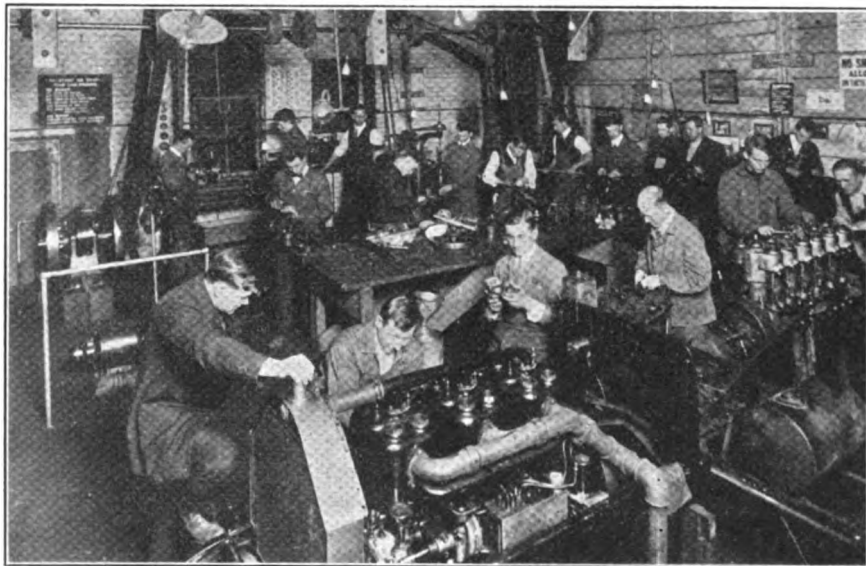

A CLASS BUSILY AT WORK OVERHAULING AND REPAIRING PARTS

3 1/8 H. P. gas engine, connected direct to the city natural gas mains. This is supplemented by an 8 H. P. electric motor turning up 1750 R.P.M. on a current of 500 volts. These are both placed with their driving pulleys quite close together and directly opposite in order to

scrap possible. It is nothing short of astonishing how soon a considerable pile of scrap is collected; but lathe turnings mixed in with the usual debris and dirt of the shop floor does not bring the high prices given for selected, clean scrap metal.

A drill press stands conveniently



between the lathes and the big work bench in the center of the room. It is protected on one side by a simply built frame of wood. (see illustration)

Next to the drill press stands the power hack saw; and beside that the grinder, with emery wheel and buffer.

There are two forges—one in the corner near a window and the other out in the room with the anvil between both and a handy tool bench conveniently placed on one side.

An "old-timer" hand-turned grind stone completes the machinery of the shop.

Two large benches are provided. The heavy one in the center of the shop is equipped with solid vises of two different types, and is used for large jobs. The other bench, running alongside the wall, is reserved for the lighter or more delicate parts of the car which are easily liable to damage. Here are adjusted, overhauled, cleaned, etc., such parts as carburetors, storage batteries, spark coils, timers, magnetos, spark plugs, etc. The idea of providing these two separate

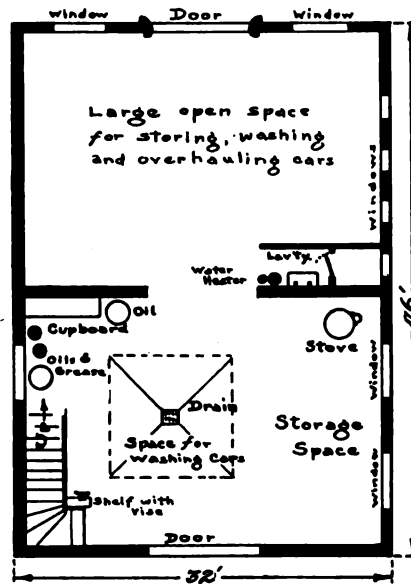

THE GROUND FLOOR PLAN

place for everything—and everything in its place.

In a dark corner, unused for anything else, stands a big metal can fitted with a pump, which contains about 50 gallons of lubricating oil.

At the other end of the shop proper, is a handy arrangement for babbitting, soldering and like jobs. A small, two-burner gas range, connected direct to the city mains, furnishes ample heat for soldering irons, melting babbitt, etc. Its well-worn appearance testifies to the amount of useful service it must have rendered. Nearby is a small bench to accommodate jobs of this character.

A box stands in an out-of-the-way corner at the head of the stairs. In it are kept a plentiful supply of clean rags—a necessity at all times in the auto repair shop.

benches, arranged like this has proved its worth time and time again; time saved in looking for misplaced parts, vexation and loss from damage to frailer parts or more intricate mechanisms. It is simply part of the spirit of order and system which pervades the shop and school: a

To proceed to the office and tool room, which is shut off from the shop itself by a partition. The office is simply arranged, there being a roll-top desk, a few office conveniences, a locked cabinet for taps, dies and valuable instruments, and the balance of the space being taken up

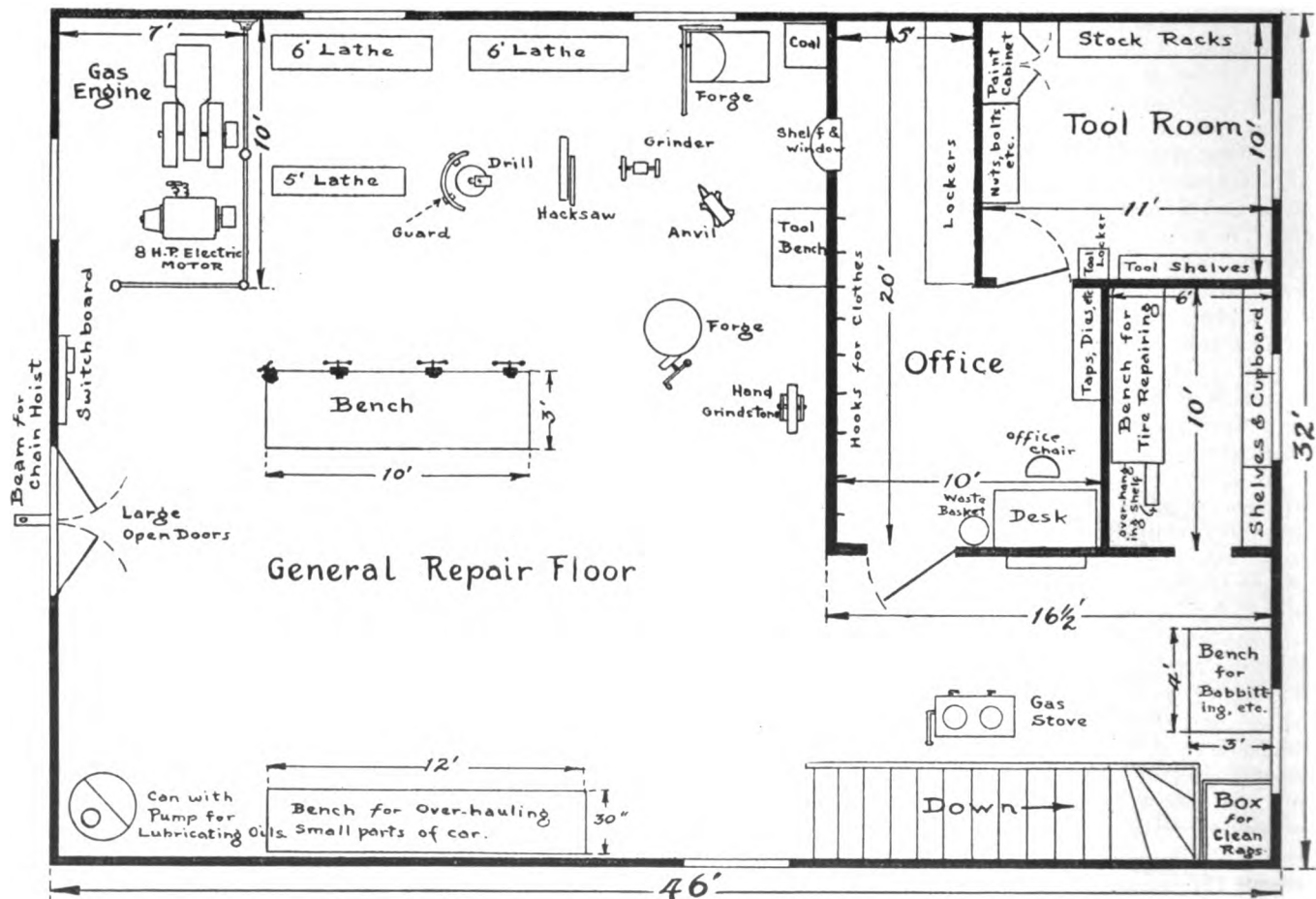

LAYOUT OF THE UPPER FLOOR. NOTE THE CONVENIENT ARRANGEMENT OF EQUIPMENT FOR EVERY PHASE OF AUTOMOBILE REPAIRING



by a locker room for students.

Hung on the outside wall of the office, near the entrance, is a card rack in which are kept Shop Record Cards for the use of students. The accompanying reproduction, showing both front and back of one, explains their use. The same idea, in a modified form, could be used to advantage by the practical repairman in checking up jobs which come to him for overhauling—sort of a trouble-hunt card.

Adjoining the office on one side is the tool room in which are kept machine and blacksmith tools, nuts, bolts, washers, screws, and the usual shop paraphernalia, stock, and a cabinet for paints and varnishes. Miscellaneous small parts are kept neatly sorted out in small, sheet-metal trays. These are placed in order on several shelves, and seem to serve the purpose much better than shelves, as the stock is more accessible and easy to see just what is wanted at a glance.

On the right hand side of the office, and separated only by a light partition five feet in height, is the tire repair room. Along one wall is a cupboard for storing tire repair supplies, and beside this is a tier of convenient shelves. Light from the windows above these furnishes plenty of illumination for the office and locker room by shining in over the partition which divides these rooms. A handy little device was added to the work bench which runs along this partition. It consists of a shelf, projecting out from the end of the bench, on which to hold tires when repairing. Hooks are placed at in-

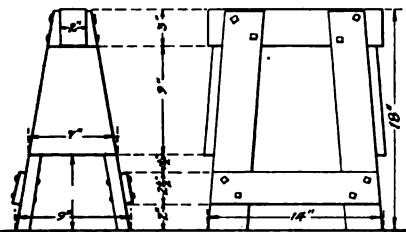

A USEFUL HORSE FOR HANDLING HEAVY PARTS IN THE AUTO SHOP

tervals at the top of the partition to hold tires.

The first floor, as before mentioned, is used for general overhauling, washing and storage of cars. There are two large doors at opposite ends of the building, with a ten foot opening in the substantial brick wall which divides the ground floor into two rooms.

The front room can accommodate

one large machine and two small ones. In one corner is a gas, hot water heater and storage tank. This has proven almost a vital necessity in every garage or repair shop as it has here. A ready quantity of warm or hot water is mighty handy in cleaning a car, washing parts, fill-

great convenience in any auto shop are a number of lamps on heavily-insulated wires and well protected by wire masks. The Y. M. C. A. shop has many of them which it uses to good advantage in going over parts of a car which are not sufficiently illuminated by the fixed lights.

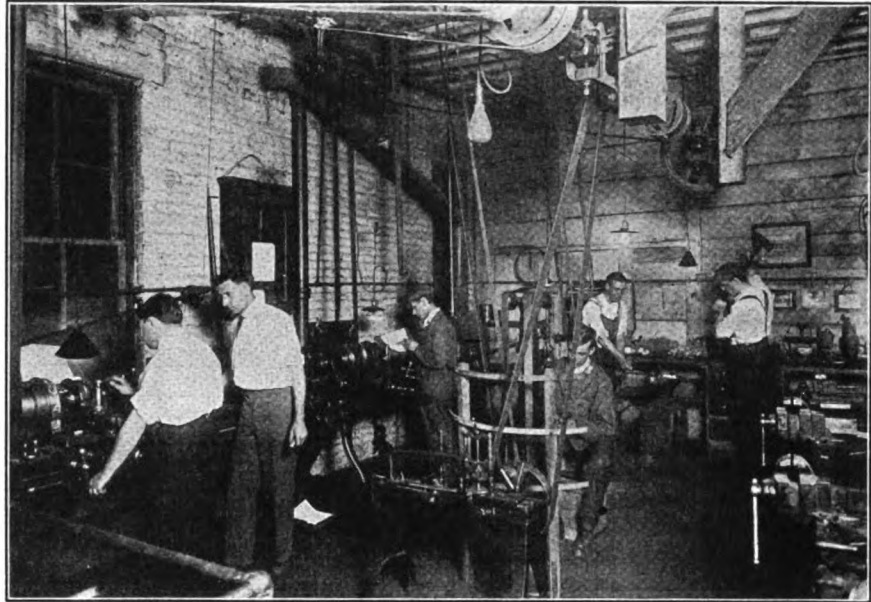

A BUSY CORNER OF THE MACHINE SHOP. NOTE THE EFFICIENT LIGHTING SYSTEM AND THE GUARD BETWEEN THE DRILL AND SAW

ing up the radiator on cold days, etc. A lavatory is placed immediately behind the water tank, which affords a plentiful supply of warm water for cleaning up at lunch time and after work.

The rear room contains a number of tanks for lubricating oils, barrels and cans for grease, and a cupboard for miscellaneous useful articles such as grease pumps, funnels, chamois, emery cloth, etc. Then there is a drain placed in the floor for washing cars, a big, round coal stove for making the place snug and welcome in winter, and a shelf with a small vise for holding small jobs.

Both floors are fully equipped with electric wiring for lights, and drop lights are placed over every machine with due regard to the operator's eyes when running it. This is an important consideration in any shop, but it is strange that many who are careful in arranging other details of their equipment, pay little attention to the question of proper lighting. The light should be high enough from the work to furnish ample clearance and to distribute it well over the job, but not so high, or so placed that it is going to glare into the operator's eyes. A

There are many interesting phases of the equipment, work and methods of the various shops which comprise the big Technical Section of the Y. M. C. A. School at Buffalo; but space does not permit of treating other than the auto shop, in this issue. In some future number we will describe the oxy-acetylene shop, the metallurgical laboratory, and the many other interesting departments.

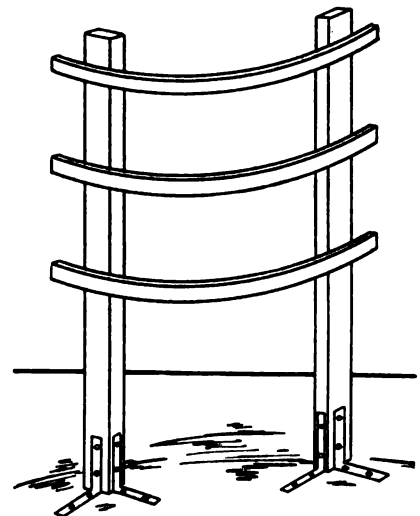

AN EASILY MADE MACHINE GUARD. STOCK: TWO UPRIGHTS 48"x2 3/4"x1 1/2" TWO BENT STRIPS 37"x1 1/2"x1 1/2"





We are glad to add that Mr. C. L. White, Technical Supervisor of the School and who is already familiar to most of our readers through his

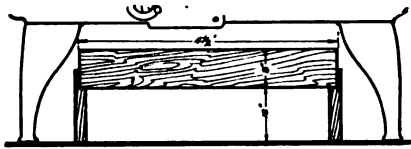

A HANDY BOX UNDER THE LATHE TO CATCH SHAVINGS CHIPS, AND OIL

valuable series of articles on "The Detection and Location of Motor Troubles", will gladly answer through the Subscribers' Service Department, any question on automobile repairing or oxy-acetylene welding, brazing and cutting, that may puzzle you.

### Stop the Leaks

E. H. MALOON

All the articles that I have ever written for publication on horse shoeing have been for the young man who is just starting in business for himself. My idea was to have him get started right in the first place and to point out to him the difference between right and wrong shoeing, and it makes all the difference in the world whether or not he does begin with the right ideas back of his work.

But there is another side to the story, and that is the financial side, which should receive the attention of every young man, that he may hope to gather a little financial wealth for his old age. And I might add that the same subject is commendable to the attention of many of the older members of the craft. This question of business is as vital to the blacksmith as it is to the tradesman. No man, no matter how hard a worker he may be, or how skilled he is at the forge, can hope to achieve any degree of independence if he neglects the business end of his shop.

I began for myself and traveled in the footsteps of my father. That is, I had no system. This I did for years, following along the old-fashioned route and making enough money for expenses with enough over to give me what I wanted for living from day to day. But as I grew older, my health began to fail, and the fact then came home to me that I must plan better and to know for a certainty just what I was getting for profit. I must know just what I was doing, what I was paying out for materials, how much time I

was spending on each job, collect what I earned, and stop all the leaks, wherever they were.

After awhile I worked out a very simple system, that I am using to this day, and it has worked out to perfection. It is to tell you how I apply it to my business that I am writing this article. So first I will have to describe what I do and how I do it.

My main business is blacksmithing and I employ two men all the year round in the shop. In addition I have a wood-working shop, (the two together covering 5,850 square feet of floor space). Here we get out specialties in the shape of bushel market boxes and biscuit crates. Here I keep a small force of men on deck all of the time, and in the summer when business is rushing in the shop, we close down the mill and all hands fall to and help make things hum in the shop. We do everything that comes along — horseshoeing, tool sharpening, implement repairing, carriage repairing, both wood and iron, make heavy dump wagons for farmers and teamsters, auto truck bodies, etc. We don't intend to turn away any jobs that promise even a small profit, nor do we intend to be forced to turn down large jobs because we are not equipped to handle them. In either case, if we did, we would probably lose a good customer.

The mill is equipped with a Foos gasolene and kerosene engine rated at 13 H. P. This drives our saws, and we begin with the rough logs

and run them right through to a finish. Of course we only handle short length logs which can be sawed into boards 21 inches long. After being cut out like this they go to a power bed machine that runs six saws, so set that they make square edge boards of just the right width to make sides, ends and bottoms for our boxes. From this machine they go to

OTHER SIDE OUT IN THE BACK.	
V. Rear Axle and Wheels	<ul style="list-style-type: none"> <li>AXLES</li> <li>Location</li> <li>... Semi Floating</li> <li>... Full Floating</li> <li>... Differentials</li> <li>Adjustment</li> <li>Lubrication</li> <li>Troubles</li> </ul>
VI. Tires	<ul style="list-style-type: none"> <li>CARINGS</li> <li>... Clincher</li> <li>... Quick Detachable</li> <li>... Demountable</li> <li>TUBES</li> <li>... Valves</li> <li>... Valve Removal</li> <li>Vulcanizing</li> <li>Patching and Retaining</li> <li>... Cuts, Inflation, etc.</li> <li>Vulcanizing</li> <li>... Fracking</li> </ul>
VII. Electric Starters	<ul style="list-style-type: none"> <li>STARTERS</li> <li>Location</li> <li>Location of Starter</li> <li>Location of Battery</li> <li>Location of Switch</li> <li>GENERATORS</li> <li>Location</li> <li>Wiring</li> <li>Voltage Control</li> <li>LIGHTING SYSTEMS</li> <li>Grounded System</li> <li>Two Wire System</li> <li>Wiring</li> <li>Wiring</li> <li>Care</li> <li>Troubles</li> <li>Battery Test</li> <li>Care</li> <li>Troubles</li> <li>Switch</li> <li>Care</li> <li>Troubles</li> </ul>
VIII. Control Systems	<ul style="list-style-type: none"> <li>BRAKES</li> <li>Location</li> <li>Adjustment</li> <li>STEERING GEAR</li> <li>Reversible</li> <li>Irreversible</li> <li>Different Types</li> <li>POWER PLANT CONTROL</li> <li>Spark Control Location</li> <li>Throttle Control Location</li> <li>CLUTCH CONTROL</li> <li>Location</li> <li>TRANSMISSION CONTROL</li> <li>Gear Shift Lever Location</li> <li>Location of Speeds</li> <li>Location of Controls</li> <li>Repair</li> <li>Rods and Knuckles</li> <li>Front Wheel</li> <li>Adjustment</li> <li>Operation</li> <li>Starter Control</li> <li>Operation</li> <li>Adjustment of Lever</li> </ul>
IX. Tools	<ul style="list-style-type: none"> <li>TOOLS. Knowledge of Use</li> <li>CARE OF CAR</li> <li>Lubrication General</li> <li>Washing</li> <li>Polishing</li> <li>STERING</li> <li>Polishing</li> <li>ACCESSORIES</li> <li>Power Tire Pumps</li> <li>Shock Absorbers</li> <li>Pre-st-O-Lite Tanks</li> <li>Bumpers</li> </ul>

### REVERSE SIDE OF THE SHOP RECORD CARD

a double cut-off saw that is arranged to take ten boards at once, each 3/8 of an inch thick, and trim both ends at once. From here they go to a press that puts them in bundles and they are then ready for shipment to our customers. If anyone has a rig that will make market boxes quicker, I'll take off my hat to him.

My engine runs both the mill and whatever machinery I use in the shop. It works 10 hours a day, turning a 30 inch saw cutting logs and the other saws all of the time, and part of the time turning such machines in the shop as we are using from time to time. We have all the power we want and it costs us not more than \$5.00 a week for the 50 odd gallons of kerosene needed for fuel.

I have been forced to give up heavy physical work myself on account of poor health and increasing age, so I have organized my establishment to relieve me of that end of it while I take general charge of its management. I have a good foreman in charge of the blacksmith shop, whom I hold responsible for all that happens. Then I take personal charge of the mill.

### No. SHOP RECORD

Y. M. C. A. AUTO SCHOOL BUFFALO

Student \_\_\_\_\_

Address \_\_\_\_\_

Class \_\_\_\_\_ Date \_\_\_\_\_

IMPORTANT!—Please check each section, subdivision or part as the study of each is finished.

I. Power Plant	<ul style="list-style-type: none"> <li>ENGINE PROPER</li> <li>Bearing Scraping</li> <li>Bearing Adjustment</li> <li>Piston Ring Remove</li> <li>COOLING SYSTEMS</li> <li>... Air Cooling</li> <li>... Water Thermo Syphon</li> <li>... Radiator</li> <li>... Pump</li> <li>LUBRICATION SYSTEMS</li> <li>... Supply Tank</li> <li>... Pump</li> <li>GASOLINE SYSTEMS</li> <li>... Tank Location</li> <li>... Vacuum System</li> <li>... Reserve Supply</li> <li>CARBURETOR ADJUSTMENT</li> <li>... Schaebler</li> <li>... Stromberg</li> <li>IGNITION SYSTEMS</li> <li>... Batteries</li> <li>... Switches</li> <li>... Make and Break</li> <li>... One Cyl. H. Tension</li> <li>... Two Cyl. Two Coil</li> <li>... Four Cyl. Four Coil</li> <li>... Four Cyl. Distributor</li> <li>... Atwater-Kent</li> <li>Carbon Remover</li> <li>VALVE GRINDING</li> <li>VALVE TIMING</li> <li>Fan</li> <li>Piping</li> <li>Troubles</li> <li>Feed Adjust</li> <li>Troubles</li> <li>Shut Off Location</li> <li>Strainer Location</li> <li>Pipe Connections</li> <li>Raysfield</li> <li>Troubles</li> <li>Wires</li> <li>Spark Plugs</li> <li>Delco</li> <li>Remy Distributor</li> <li>Rem. H. T. Mag.</li> <li>Huh T. Mag.</li> <li>Dual Ignition</li> <li>Troubles</li> <li>Lubrication</li> <li>Care</li> <li>Selective</li> <li>Friction Drive</li> <li>Lubrication</li> <li>Troubles</li> <li>Adjustment</li> <li>Universal Joints</li> <li>Repair</li> <li>Care</li> </ul>
II. Clutch	<ul style="list-style-type: none"> <li>Study of Types</li> <li>Adjustment</li> <li>Lubrication</li> <li>Care</li> </ul>
III. Transmission	<ul style="list-style-type: none"> <li>Planetary</li> <li>Sliding Gear</li> <li>Preselective</li> <li>Semi Selective</li> <li>Selective</li> <li>Friction Drive</li> <li>Lubrication</li> <li>Troubles</li> </ul>
IV. Drive	<ul style="list-style-type: none"> <li>Chains</li> <li>Shaft</li> <li>Adjustment</li> <li>Universal Joints</li> <li>Repair</li> <li>Care</li> </ul>

THIS SIDE OUT IN THE BACK. Check Other Side.

THE SHOP CARD USED BY STUDENTS IN THE Y. M. C. A. AUTO SCHOOL



It is absolutely necessary under this arrangement, and with the amount of business we carry on, to keep in perfect touch at all times with just what is going on. And I work it out as follows: In the morn-

I keep business right up to the mark and make all possible progress ahead by referring each week to what we did during the corresponding period last year. Then I say to my foreman, "You must earn me so

eternal vigilance, but it pays me and it will pay you.

### A Progressive Nebraska Shop and Its Efficient System

"It is Sunday, and my copy of the American Blacksmith has just arrived. Although I am a very busy man, I always take time to read 'Our Journal' just as I would a letter from home—and incidentally take 'home' some of its valuable suggestions.

"It is about time I settled my obligations to the best craft paper by contributing something of my own experience for the benefit of others—as I have benefited by their experiences heretofore."

So writes Mr. J. W. Pokorny,



MR. MALOON AND HIS EFFICIENT FORCE OF WORKERS

ing I give my foreman a bag of change to use throughout the day. At night he returns it to me together with a record of all that he has done for the day, which is simply noted on a pad of writing paper. This is settled every night at the close of work and has to balance. The men work by the hour on jobs, weighing their stock. I figure out how much they shall get per hour and that is all put together so I know just what

much on an average for this week." And if he falls short, I get after the trouble at once and it is quickly remedied.

My bookkeeping system is designed to keep close tabs on every item, and to watch for and stop the leaks. That is perhaps the most vulnerable place in any business. There are so many little places, here and there, that permit a bit to leak away unobserved, that when the whole sum is added up, the loss is greater than one would hardly believe.

From the shop pad that the foreman gives me each day, I check the items off to a day book. Each day's charging and cash is added separately and charged off onto blacksmith and mill accounts in a ledger. I keep the two accounts separate. These accounts are balanced every month, showing me profit or loss and just where it occurs. My bills are charged off in the same manner and whose bill it is. My bookkeeper gives me a statement each month of all bills outstanding and all accounts unsettled and I do all my settling by these sheets.

Now my advice to you is this: collect all your bills in cash, don't dicker. My way is to press my customers when I know they can pay and I generally get it. Out of nearly \$1,000 per month I don't lose \$10 per year in bad bills. This is not all simply in collecting. I learn all I can about the men in town in a general way and I don't make bad bills. When a man gets shaky I drop him. This means

Name Tom Moran

Article one casting

Received 6/15/17

Promised 6/16 - 4 P.M.

Job Weld and rebore

Done by J.W.P.

Price \$ 2.00 Paid 4.00

**REMARKS**

Ship to Agnew

by express.

**O. K. SHOP,**  
J.W. Pokorny. :: Prop.

EVERY JOB THAT COMES INTO MR. POKORNY'S SHOP IS TAGGED LIKE THIS

who runs the O. K. Shop in a live Nebraska town. He continues:

"I have a new shop, size 74 by 80 feet and employ four men. We are equipped to do all sorts of repairing and general work, having a good equipment and all sorts of tools. We



A CORNER OF THE BLACKSMITH SHOP. MR. MALOON IS AT THE RIGHT

each job actually costs. Their pay by the hour is reckoned on the basis of their wages and my overhead expenses, which include interest, insurance, taxes, water, lights and rent.



have just put in a new cold tire setter, a disc roller and an oxy-acetylene welder; and carry as a side line to our regular business, gas engines, tractors, cream separators, and implements of all sorts, which command a ready sale.

"We are charging more for our work than anyone around here and getting the business just the same. It is the service that counts every time and not the price. I have been up against keen competition for several years and nine different men have tried to run shops, most of them working cheap, but I have always stood for quality and service and paid no attention to cheap competition. Now I have the only shop in the place and get a large percentage of work from surrounding towns in ad-

"The advantages of such a system are easily apparent. In the first place it is simplicity itself. The tagging and jotting down of the various remarks takes but a moment, but that moment spent in so doing is worth more than all the moments wasted in hunting up a job that has become mixed up with others. This is particularly true where many small parts, or work of an extremely common character such as shares and shovels, are being handled. They are sometimes hard to keep track of and very often a customer gets someone else's part and then there is trouble. But our tag system eliminates all such errors. And it helps us to avoid any possible trouble later over prices. With the charge on each ticket and the boss

have been getting more and more of the business until finally our cheap competitors have all bid us good-bye; never to return.

"We started our plan of efficiency when our competitors were going it strong, but we got to liking it so well, that even after they had left we went right ahead and stuck to it. And we are continually devising new ways to eliminate delays and improve our service. When we cannot do away with delays altogether, we shorten them as much as possible. And now we are getting business from nearby towns *where they charge a good deal less than we do.* In this age of automobiles and rapid transportation, miles are of far less importance than a few hours; and in these days of \$14.00 hogs and dollar corn a few cents difference in prices does not scare many away if they know they are getting quality, service, and can depend upon getting their work when promised.

"You can buy an Ingersoll watch for a dollar, but it isn't everyone who buys an Ingersoll. Although a Ford is not high in price, Packards find a ready sale. It is true that a Ford 'gets there', but the price cutter never does unless he is headed for the poor house."

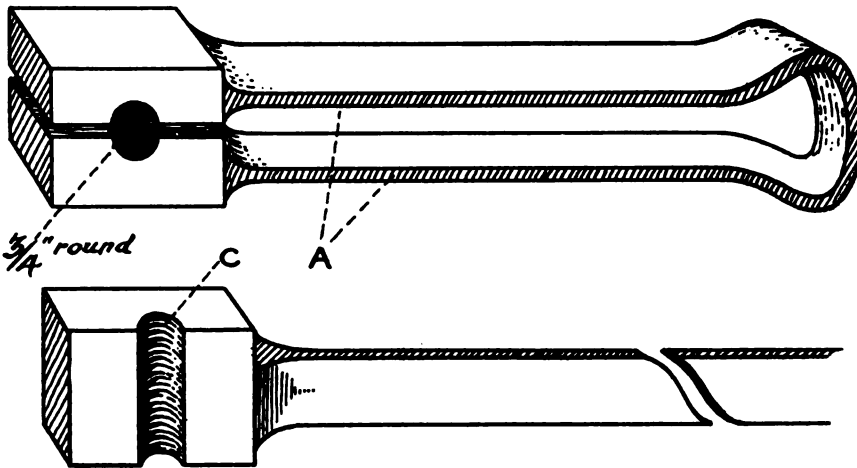

FIG. 1.—ROUND SWAGE

dition to local jobs that keep all of us hustling.

"We eliminate as many delays as possible by making up a quantity of spare parts that are continually called for and may be needed quickly at any time—parts such as king and queen bolts, wagon hammers, hammer straps, open links, ready-made bolsters, reaches, etc., and keep a lot of stock on hand for emergencies.

"Then we employ a system of tagging jobs that has helped to almost annihilate errors in our shop. As each job comes in it is promptly tagged with a card similar to that shown here. The various items are filled in by whoever receives the work, and the price is made, if possible, at the time the job is taken. If the customer pays for it then, we mark it paid. If not, it is noted on the ticket and later the cards are hung on a hook to be gathered up at the end of the day where they are taken into the office, checked over, and proper charges made on our books.

out, whoever delivers the finished job knows just what to charge. And they also help to keep before us the time the customer is to call for his work.

"The cost of these tags is small, and the advertising feature is worth something. But above all they put into operation a system that has given us a reputation for prompt and efficient service such as cause remarks like these from our customers:

"'When you go to the O. K. Shop with a job, you meet yourself coming out with the job already done.'

"Or—'Jim has finished your job while you are reaching for your pocketbook to pay him.

"Another says, 'If you are in a hurry, go to Jim's.'

"Yes, occasionally we get a kick from someone who wants us to work at the other fellow's prices. But we always tell him that it costs more to ship goods by express than by slow freight, and he usually 'gets us' and stays. We have hung onto our prices, all the time giving good service and

## Put the Power-Hammer to Work—2

WILL BISHOP

We anvil-wallopers don't beat the devil's tattoo on the anvil every day because it's funny, nor altogether because we are fond of music. We do it because old H. C. O. Living, with spurs on both heels and a rawhide whip in his hand, rides us like a busted jockey rides a wind-broken skate in the last race at the County Fair. That jockey needs the money—and so do we. And if we can get the money—more of it and easier—that's the dope that looks good to all of us. Because I know that if you make him work, Power Hammer will slip you a lot of extra change, I am passing along to those who are not well acquainted with him what I have learned of the old boy's capacity for doing things, and the tools to hand him to do them with.

As I stated in the last issue of Our Journal, I will take up in this issue the making and using of hammer-swages. There are several kinds of hammer-swages that can be used to great advantage in the general shop. One of the most important is the common round swage, a sketch of

which is seen at Fig. 1. This swage can be made in one solid forging, or the handle part can be welded on. That's up to the maker. For the purpose of illustration, I'll explain the method of making a  $\frac{3}{4}$ " swage in one solid forging. A piece of stock  $1\frac{1}{4}$ "

of the ball, directly opposite the shank. This should be tapered out to about  $\frac{1}{4}$  of an inch in diameter, and be left long enough so that it will reach beyond the edge of the block when the ball impression is being made. Note this small groove at

queen's taste is a shackle, or clevis, seen at C. Simply take a piece of  $1\frac{1}{4}$ " round iron of whatever length is required to make the clevis desired, heat one end to a good white heat, place in the balling-swage so that it will fill up the form, slap 'er under the hammer and strike moderate blows, at the same time give your heat a half-turn at every stroke of the hammer. When the swage blocks come together, take 'er out, and you have a neat  $1\frac{1}{4}$ " ball on a  $\frac{3}{4}$ " shank on that end. Now repeat the process on the other end, draw out center under hammer until it will go into a  $\frac{3}{4}$ " round swage and place in swage and round up. Then flatten the balls down to  $\frac{7}{8}$ " thick, punch holes the size you require and bend to suit. There; you have a clevis that is much stronger, much quicker make, and, by long odds, neater than can be done by bending and welding the eyes. If you want an S-wrench that looks as if it had been molded, make same as clevis, only shorter between balls, flatten balls down to  $\frac{5}{8}$ ", and center to  $\frac{3}{8}$ ", punch hole in center of flattened ball and cut out to fit nut required. Try it. It makes a beauty, and takes only a few minutes.

Here's another one. Take a squint at 'er in Fig. 3. This is a half-section sketch of a Collaring-Swage, and shows swage designed to make brake-roller ends, body-brace ends and so forth. Of course, it will be readily understood that this swage is to be made to suit the work required of it. Simply make the model of the job required and make the impression in the swage, and the tool is ready to turn as many pieces of the work as

$\times 2\frac{1}{2}$ "  $\times 8$ " is required to make this tool. Fuller in all round,  $2\frac{1}{2}$ " from each end of stock, which leaves 3" in center to be drawn out for the swage handle. Draw out the handle to about  $5/16$ "  $\times 1\frac{1}{2}$ " all the way along, with a gradual increase in thickness from A to the swage heads. When this is done heat one swage head and make the groove (note groove in Fig. 1 at C) across center. To do this, it is best to use a piece of  $\frac{1}{2}$ " round iron to start the groove, being careful to not make too deep, following with a piece of  $5/8$ " round. Do this to both ends of the job, and bend as in Fig. 1, bringing the grooves to match. After this, heat both blocks of the swage head to a fair heat and place in the groove between the blocks a nice, smooth piece of  $\frac{3}{4}$ " round, hold her under the hammer and strike lightly until the swage blocks come together, at the same time keep turning the  $\frac{3}{4}$ " round in the tool. This swage can be made in any size desired, from  $\frac{1}{4}$ " to as large as can be used under the hammer for which it is designed.

Next in importance—if not equally as important—to the round swage is the balling-swage. With the exception of the groove, or form, this swage is made identically the same as the round swage. At Fig. 2 is a sketch of a half-section of this tool showing the ball and shank impression in the swage head. To assure perfect accuracy in the ball-form, the ball and shank with which the impression in the swage heads is made should be turned on a lathe. In turning this ball, there should

be left a "boss", or tit, on the top the ball and shank with which the impression is made. The best way to make the impression in this swage is to use two separate balls, starting the impression with one considerably smaller than the one used for finishing. This gives a clearer, neater impression. For illustration, I'll give method of making swage with a  $\frac{3}{4}$ " shank, and a  $1\frac{1}{4}$ " ball diameter. After the swage is made as in Fig. 1, minus the groove, heat the heads to a fairly soft heat, place a 1" ball with a  $5/8$ " shank between the blocks, hold under the hammer and drive down until the blocks come together, turning the ball as you hammer. Then take out and put in the  $1\frac{1}{4}$ " ball with the  $\frac{3}{4}$ " shank and drive

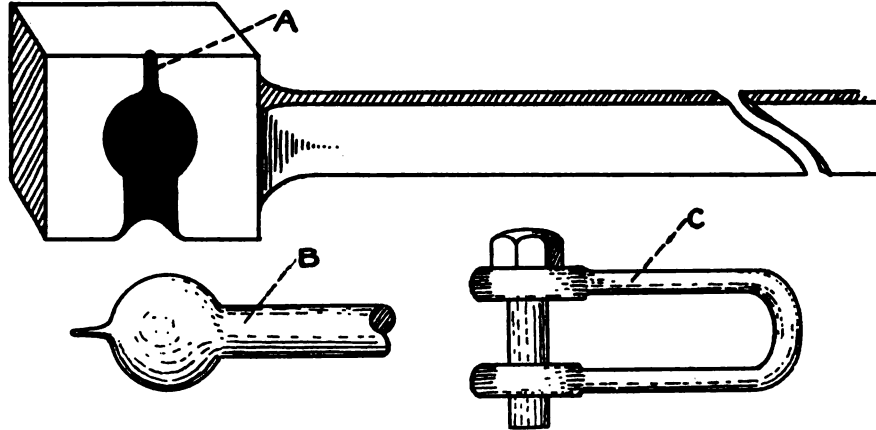

FIG. 2—BALLING-SWAGE

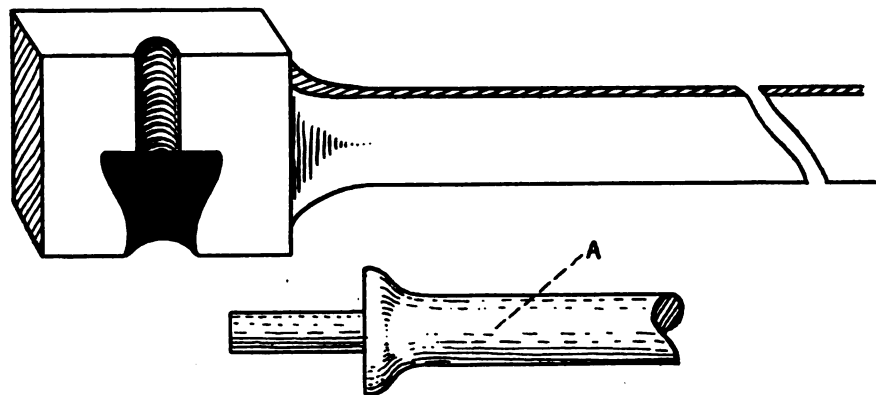

FIG. 3—COLLARING-SWAGE

down as before. This finishes the tool.

Now, how to use this tool, and what for. A good example of the work the balling-swage will do to a

is wanted, and exactly like the model. All you have to do is let the swage and Old Man Hammer do the work. You merely boss the job and see that it is done right. At section A is a sketch of the model for mak-



ing this tool. If it is impossible to have this model turned up on a lathe, forge it out as near perfectly proportioned as possible—two of them, remember; one smaller than the one to be used for finishing—and make in exactly the same manner as described for making the balling-swage in Fig. 2. Another thing, while I think of it, in forging a ball in the balling-swage, or a piece of collared work in the collaring-swage, be sure to use a piece of round stock of exactly the same diameter as the greatest diameter of the ball, or of the collar, as the case may be. Just heat white hot and place in the swage and it does the rest. You may spoil a few; but after a few trials you'll get 'er pat.

Now, it is to be remembered that these sketches and descriptions by no means show all the tools in this line that the ingenious smith can easily make. Just bear in mind that almost any forging that will permit the operator to turn the work in the swage while hammering can be successfully done with swage and hammer. Swages for all work that they can be used for tend to standardize the work of the smith. They make his work absolutely uniform, give it individuality, and it soon becomes recognized by shop patrons as Brown's work, or Jenkins' work, as the case may be. This, as we all know, means boosting of business, and is the most legitimate of boosts.

The above described tools for the hammer are easily and quickly made, as are others that, with this pointer, will suggest themselves to the quick-witted iron-clouter; and every smith that has a hammer which he has not been getting proper action on should get busy and make himself a set of each one described, along with others that he sees the need for. And those readers that have no hammer should grab Our Journal, look over the many hammers they will find advertised therein, pick out and order the one that suits their needs and thus gather into their shops the longest winded, hardest hitting, neatest and most faithful little old worker that ever slugged a piece of red iron. One smith and helper, with a hammer and hammer tools, can do more, better, and neater work in a day than two smiths and two helpers can do by hand.

Of course, it's understood that to use these tools properly the smith must have a helper, and the helper must be trained to their use. It's the

helper's job to hold the tools under the hammer while the smith operates it and handles the heat. With a little practice, the smith and helper soon learn to work together to their mutual ease and satisfaction, and to the turning out of work which they are both proud of. Give it a trial, boys; you'll learn to kind'er like Old Man Power Hammer when you know him better.

## The Oxy-Acetylene Plant—5

Its Installation, Operation, and Torch Manipulation

DAVID BAXTER

### Handling the Torch

In this chapter we will endeavor to give pointed advice and instruction on the handling and care of the welding torch, or, as it is frequently called, the blow-pipe. Of equal importance to the generator, the blow-pipe should be chosen with an eye to its adaptation to the work it is to be used for. It pays in the long run to buy a torch fully equipped with all sizes of tips. It should also be adjustable, because it frequently happens that the operator finds it necessary to use a long torch and long tip in order to reach the weld and to protect himself from the heated metal. While under ordinary circumstances a short torch is the best and most easily handled, not only on account of its lighter weight, but because the flame can be more readily directed, it happens that the operator is compelled to reach over a very hot surface to get at the weld. In such a case he should have another long torch or be able to quickly lengthen a short one. Then as to further avoid the heat, an ingenious workman can devise an adjustable shield to be fastened to the handle of his torch. This furnishes a good measure of protection which is quite necessary at times.

A fully equipped torch has from six to a dozen or more tips. These tips, or nozzles as they are sometimes called, regulate the flame with regards to size. They are of different shape and size according to the make of torch and the work expected of them. Some kinds are made to fit one another, and by so doing form a tip several feet in length. Such a lengthened tip is found very handy, in particular where the welding is done down in a deep pocket, or back of immovable obstacles.

The torch and tips, while very sub-

stantial are in reality a delicate instrument, and should be taken care of as such. When the operator learns of its possibilities and power, he can work wonders with it.

The various tips consume varying amounts of gases, partly due to the

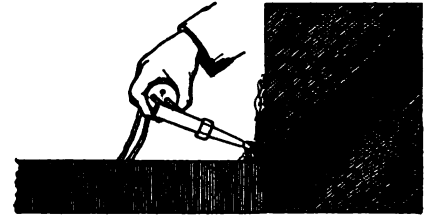

FIG. 1.—A DIFFICULT JOB AND HOW IT IS DONE. HOLDING THE TORCH IN THE RIGHT HAND HELPS TO DIRECT THE FLAME WITH GREATER ACCURACY IN TIGHT PLACES

size of the tip. So the first thing to do in handling the torch is to see that it is equipped or fitted with the proper tip which means a material saving in gas. The tips should vary with the depth and size of the weld to be made. When welding a very light casting, choose a tip having a small hole through it; while on heavy work, a longer tip with large hole should be used. The proper changing of the tips not only saves gas but frequently prevents the weld from being burned, and saves time and permits the weld to be finished before contraction sets in.

As the manipulating of the torch is a very important part of the welding process, an operator, if not left-handed, should hold the torch in his right hand (Fig. 1)—as it can usually be held steadier and the flame directed with greater accuracy. Skillful manipulating of the torch helps to make cleaner metal in the weld by driving away the air, and by keeping the metal all melted where it should be. It is important that the faces of the break should be sufficiently heated when the new metal is added. They should be fluid, or nearly so. This means the entire surface—not merely a few spots.

If the place to be welded is fluid or nearly so when the new metal is added, which is also melted, we know they will mix and become one piece of metal. If they are not melted together they may eventually come apart; and that too, after the weld is finished when it is apt to prove embarrassing, if not resulting in the loss of a customer.

The break should first be grooved in the prescribed manner. The



operator then melts some of the metal from the sides of the V and joins it at the bottom in a molten condition. To this molten metal add more molten metal from the filling-rod. Always remember to keep the sides of the V melting, and add more metal until the V is filled.

In heating the surface in preparation for fresh metal, the torch should be kept in motion, swinging around in tiny circles, either to the right or left, and always moving slowly onward (Fig. 2). This distributes the heat over the desired surface, and melts without burning the metal. Be careful not to hold the point of the flame too close to the metal after it is melted, for more than a few seconds, without adding new metal. After metal reaches a white-hot melt, it will burn in almost an instant if the flame is allowed to touch it, or is held steady and close to it. Keep the torch in motion, especially after the metal starts melting.

Some metals are discolored by absorbing oxygen from the air. This may be overcome to a great extent by manipulating the torch in a way to spread the outer flame over the work. On the majority of jobs, the torch should be held as near as possible in the direction of the line of weld, and not perpendicular to it. By holding the tip perpendicular we endanger it to overheating, resulting in a loss of time necessary to change tips or to cool the overheated one. Also, an overheated tip is liable to back-fire and may result in a dangerous flash-back.

A flash-back is caused by the flame being carried back past the torch toward the acetylene chamber. Back-firing is premature ignition in the mixing chamber. Both of the troubles are caused by overheating the tip; some of it is due to carelessness in holding the tip too close to the weld, and some is unavoidable when welding between the steep sides of a weld. An overheated tip may be cooled by dipping in water, after shutting off the gases.

Under certain conditions the flame affects the tip, sometimes resulting in melting the tip. If an operator is working on a casting which, from its shape causes the heat and flame to be thrown back around the torch, and this is continued for several minutes, it will cause the tip to become very hot and result in back-firing or melting. Backfiring is detected by sharp cracking noises or miniature explosions. It is not necessarily dangerous, although rather

startling. Should the weld be located between two steep walls of metal, where the heat is closely confined, an operator should be very careful, because the tip will melt in a comparatively short time.

On the other hand the flame might be kept burning all day, scarcely heating the tip, provided the flame is not thrown back around it. This is accounted for by the fact that the pressure of the gases blows away the heat. The cooler the gases, the better the flame for welding purposes.

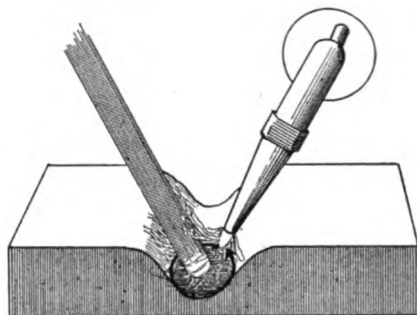

FIG. 2—IT IS NECESSARY TO KEEP THE TORCH IN MOTION, SWINGING AROUND IN TINY CIRCLES

Acetylene gas has a bad effect upon rubber, so the operator should examine his hose from time to time. He may be thus able to prevent a fire or explosion.

(To be Continued)

## Gas Engine Operation Made Simple—10

The Purchase, Installation, Operation and Troubles of a Gas Engine.

J. L. HOBBS

### Wiring

Having pretty thoroughly gone into the different types of batteries and magnetos we will now turn our attention to the wiring of these systems. This wiring is very simple when explained in simple language. Of course if you go to talking about the positive and negative poles of the batteries and magnetos the reader gets confused easily, but if you speak of them as the carbon and zinc or copper and zinc of the batteries, this can be understood by anyone as everybody knows what zinc is, which is all that is necessary to know.

While it is customary to start your wiring by running a wire from some metal part of the engine to the first zinc post of the battery, this wire can be run to the carbon post with the same result. Take another wire from the carbon post to the zinc post of the next battery, being careful at all times to connect a zinc to a

carbon all the way through. You will find that you have a carbon post left. Put a wire from this to the coil box. Another wire from the other post of the coil box to the switch and another from the vacant post of the switch to the igniter and the wiring for a simple battery operated engine is completed.

If you wish to put a magneto onto this engine which requires the use of a coil box, you will release the wire which goes from the battery to the coil and place it on one side of a three post switch. From the center post of the switch run your wire to one post of your coil and from the other post of the coil to the igniter. Then place the magneto in position as previously described in a preceding paragraph. Run a wire from one post of the magneto to the frame of the engine and the other to the vacant post on your switch and the job is done. By moving the switch to the battery side you get battery current, and when placed on the magneto side you get magneto current. In wiring, no attention is paid as to which post of the coil or magneto is used first, as either post may be connected with any other post.

If you wish to connect a magneto with this circuit which does not require a coil, just take the coil out of the circuit between the switch and igniter and put it in the circuit between the battery and switch. You will see that the magneto current now goes direct to the igniter, while the battery current goes through the coil and then to the igniter.

The battery should be placed in a clean dry place, where it will be free from vibration. Not that vibration hurts the battery, but it is very trying on the wiring, and will eventually cause trouble. Let us give you a little experience: An engine was running along nicely on batteries, the ordinary dry cells being used, and it being a portable engine the batteries were set loosely into the battery box which was attached to the engine frame. There was of course a certain amount of vibration. This vibration in time broke one of the little wire connections between the batteries. This wire being broken beneath the insulation and not being visible to the eye was of course hard to find. A battery tester was used to test the batteries singly and then the set was tested, singly they all tested good, but as a set they tested nothing at all. We then commenced at one end and added another battery at each test until we



failed to get results, when finally we took hold of the little connecting wire and found the trouble. When a new wire was supplied the engine was ready to go again. This would no doubt cause a novice quite a little trouble, but you can see that it was not a hard job when followed by a system. Always have system in your work. Begin at a certain place and go a certain way until you find your trouble. Be sure of one thing—that the trouble is always there and it is up to you to find it.

Be sure that your connections are all tight. A loose connection on a battery, coil, or magneto is hard to find and will cause no end of trouble. It may be loose enough to cause the engine to simply mis-fire occasionally, or it may be loose enough to cause the engine to fail entirely. If your engine stops without apparent cause, look to your wiring the first thing. The trouble will either be there or in the absence of fuel from the carbureter. A dead battery spoils the force of the good ones in a circuit.

(To be Continued)

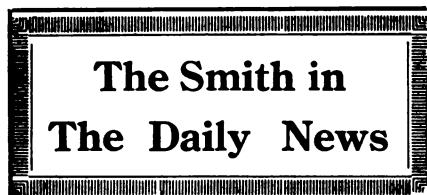

#### Odd Mention of Anvil Ringers and Knights of the Forge in the News of the Day

#### A Handy Man Who Has His Hands Full

The village of Tilghmanton, Md., boasts of a handy man, named John Sweitzer, who is a "Jack-o'-all trades"—and more. The old saw does not run true in his case, for Mr. Sweitzer is truly *master* of each one of the various trades he follows.

To be a blacksmith, tinsmith, wagon maker, broom maker and a barber is enough to keep any man busy, and we are informed that Mr. Sweitzer never has any idle time on his hands.

Nearby his residence Mr. Sweitzer has a shop in which he works at all of the foregoing trades. The building is equipped for each department of his work. While not shaving or cutting the hair of some of the residents of the community, Mr. Sweitzer will be found making brooms for the busy housewives of his neighborhood, or building or repairing wagons or shoeing horses for the farmers. When some industrious housewife wants her washboiler or coffee pot mended, Mr. Sweitzer is on the job.

And one line comes as handily to him as any other. Residents of the community are convinced that they would be at a serious loss if Mr. Sweitzer should leave and he is duly appreciated by all the people.

#### Men With Trades Join Army

There has been a great rush to enlist under modified terms of service, and men

with trades are being eagerly sought as army recruits. For the first time, a flood of applications is beginning to pour in to the recruiting stations in New York. The prospect of early service abroad is entirely responsible for this, although the action of the war department recently ordering the enlistment of men between eighteen and thirty-five for a period of one year only on active service and six years with the reserve has made the service more attractive.

Since the issuance of this order, recruiting stations everywhere had an unprecedented number of applications. The trades most in demand are clerks, stenographers, *automobile drivers, automobile machinists, blacksmiths, cooks, bakers, teamsters, wheelwrights, carpenters, firemen, farriers, engineers and saddlers.*

#### Duluth, (Minn.) Smithies Parade

The big, patriotic parade, held recently in Duluth, was a splendid success and an inspiring spectacle. The blacksmiths were represented by a fine body of sturdy men. They showed that they were solidly behind President Wilson in the national emergency by closing every horse-shoeing shop in the city expressly for the occasion, and passing a joint resolution that "they pledge their loyalty to the flag and their support of the president.

#### And Still Prices Go Up!

As this issue goes to press we find reports of continually advancing prices for shoeing, etc.

The blacksmiths of Montgomery, N. Y., and other nearby places have formed a combination, to charge the following advanced prices, owing to the high cost of material:

New shoes, 0 to 4, \$1.75; 5, \$2.00; 6, \$2.25; 7, \$2.50; 8, \$3.00; setting 4 shoes, 0 to 4, \$1.00; 5 to 7, \$1.25; hand-made shoes, \$3.00; leather pads, 60 cents a pair.

The blacksmiths of Boone and Hamilton counties, Indiana, have agreed to a new schedule of prices to go into effect immediately. The former price for shoeing a horse ranged from \$1.25 to \$1.50. The new schedule is from \$1.50 to \$2. The increase in the cost of living and the price of material is given as the reason for the advance. Other blacksmith work also will cost more.

Reports from the blacksmiths of Fitchburg, Mass., reveal the general feeling that still higher prices will have to be charged. Figures, which have been kept by them, show an alarming advance in the cost of several kinds of materials, from 200% to about 500%. They hold that an increase is justified, not alone on account of the higher cost of materials, but because of the larger amount of money which they, in common with the rest of humanity, have to pay for edibles, wearables, and nearly everything else which comes under the head of every-day expenses.

A general advance in the price of horse-shoeing and resetting has been announced by the Dayton (Ohio) Horseshoers' association through C. P. Coblenz, the president, because of the great advance which has entered into the cost of everything used by shoers. Under the new prices shoeing will cost \$2.20 per set, and setting \$1.40 per set.

#### High Cost of Funerals Next

Blacksmiths are not the only ones suffering from the H. C. of L. Indeed, they themselves have been instrumental in making the high cost of living greater for others and have even gone so far as to in-

crease the high cost of dying!

We hear that the coach owners of New York City have organized and agreed that, because of the present high cost of getting their steeds shod, hereafter no funeral will be conducted at a lower rate than \$5.00 a coach, and that each owner is a law unto himself when it comes to making his maximum price.

#### Another Queer Shop Combination

We have heard of a barber shop, a watchmaker's establishment, and other trades and professions being run in connection with the village smithy, but here's the limit: a fish market at one end and a shoeing business at the other end of the shop!

Just how such an arrangement came about was due to the fact that the fish concern was driven from its former place of business by fire, and after several day's search made arrangements with the proprietor of the blacksmith shop to use the rear of his place.

The combination can hardly be said to be satisfactory—at least to neighbors. For they claim, in a petition to the local health department that such nauseating odors emanate from the building as to endanger their health and happiness!

We can easily imagine what an elusive, exhilarating and ambrosial joy must be wafted through the doors of that smithy and how it must even intoxicate the horses being shod therein!

#### Another Way to Solve the Price Question

Indiana blacksmiths in Fort Wayne have concluded that, rather than increase their charges, they will operate in the future on a strictly cash basis. They figure that the loss incurred through bad debts, poor and slow collections about offset the increased cost of supplies used in their business.

#### Horseshoers Pledge Their Support to Uncle Sam

Michigan State Association of Master Horseshoers which convened in Grand Rapids recently, has pledged its support to aid the government by adopting a resolution urging that horses be equipped with intelligent care and skill requisite for their greater service in any emergency which may arise. The association realizes that the conservation of the army horse depends largely upon scientific shoeing. A report was read showing the increasing popularity of the automobile. The government report shows 5,000,000 more horses on farms than ten years ago. At a meeting of the executive committee preliminary to the main session of the twenty-fourth convention a plan to establish a class for the study of the anatomy of the horse at the Michigan Agricultural college was formulated and it was decided that at the next session of the legislature the association will make an effort to secure the passage of a bill requiring an examination for horseshoers.

#### Wife as Escort Will Keep Blacksmith from Jail

If Harvey Williams, an Emporia (Kansas) blacksmith, is seen on Emporia streets except in the company of his wife, he must serve a three months' jail sentence. Williams, convicted on a disorderly charge, was given three months in jail by the Rev. J. H. J. Rice, the Emporia police judge, and paroled. He will be allowed to travel from his shop to his home unmolested, but otherwise he may leave home only in the company of his wife. Williams accepted the conditions of his parole.



## The Old Flag

WALTER G. DOTY

Let it quietly wave o'er the breasts of the brave  
Where they sleep in the mountain or dell,  
Or, high on the staff, let it dimple and laugh  
In the breezes that love it so well.  
Oh, banner of light, with your crimson and white,  
With your field of the heaven's own blue,  
And your glorious stars brighter made by the scars  
That our heroes have suffered for you:

Float ever, droop never, forever, old flag!  
Though the armed world assail you,  
What coward would lag  
To rise in defense of our beautiful flag?

By a thousand campfires have the vows of our sires  
Ever been that the flag should still reign;  
And they battled and bled till the rivers ran red,  
But the flag floated free from all stain.  
Let us keep it unfurled to enlighten the world—  
Right's emblem as ages go by.  
Ever glad to the sight is that banner so bright,  
As it ripples in glory on high.

—National Magazine.



## Heats, Sparks, Welds

Cheer up for today—it'll make tomorrow easier.

When competitors are friends, then comes co-operation.

Nobody who looks straight ahead is in much danger of getting very crooked.

Business is just exactly what it means—busy-ness. Ever think of it that way?

Right thinking and right working are a combination that will make success stare you in the face.

Satisfied customers make a satisfied shop owner, which is good for both customer and blacksmith.

Who is running your business—yourself, your helper, your customers, or your competitor? And why?

As Bill Forger says: "Yes, it is always good policy to mix in a little business between the war reports, for business, you know, is what keeps the table set."

Pete Crowthers shrewdly remarks, "When a man buys a cheap article, he feels good

when he pays for it, and then feels rotten when he is using it. But when he buys a quality article, he feels good every time he uses it, and he thinks about the quality long after he forgets about the price."

There are two ways of finding profits. One is with a microscope; the other is with a good bookkeeping system. How do you go about it?

"It's hard to account for sum things," says ol' Cuff Brasher, an' one of them things is sum of the accountin' y' find in smith shops." And we are forced to agree with Cuff.

Stamp yourself as a progressive, wide-awake smith. Use your Pink Buffalo Stamps whenever you write to a brother craftsman or do business with an out of town concern.

Think-think-THINK!—about your work and about yourself. But stop a moment: which do you think most important—what you think of yourself, and your work; or what other people think of you? Think it over.

A good practical shoer and jobber will find an opportunity awaiting him if he writes to Mr. C. L. Lyman, of Becket, Mass. Mr. Lyman needs a good man right away, so better write quick if your services are in the market.

Important books of the trade are catalogues. Keep them on hand in a handy place. You will find many of them contain information on your business that you can get from no other source. A file of trade catalogues is just as necessary as a file of the other kind.

Did it ever occur to you that bills are like dogs: when they are young you can easily handle them. Keep your bills—both bills payable and bills receivable young, and you can take care of them easily. When a bill once gets old, it's pretty hard to get the money whether you owe it or whether someone else owes it to you.

"A little knowledge is a dangerous thing," so runs the old proverb. Why not be fully informed on subjects vital to your welfare? We have a selected list of books on blacksmithing, horseshoeing, forging and iron working, automobile repairing, oxy-acetylene welding, and kindred lines. Furthermore, we can supply you with any book you desire. Just ask Subscriber's Service.

Successful business men believe in advertising. And one way to advertise a store is through its attractive show windows. In the same way a smith shop advertises itself—only the shop doors take the place of the store windows. How about yours? Would a passerby, on looking through your door, see a neat, orderly shop, busy workers, hear the hum of machinery, the putt-putt of your gas engine, the merry ring of your anvil, and pass on with the impression that your place was one of the successful establishments of the town?

Yes, it costs more to live today—but isn't it worth more? "The good old times" that we hear so much about, were all right in their place, but today things are better all 'round and progressing everywhere. Despite what the pessimists have to say, conditions are generally better. Our good old craft, for example, is progressing. It is in better condition and will still become better with the added introduction of improved methods. Yes, living is worth more today—and just re-

member that when giving a price on your next job.

Off' times we suggest that readers send us an occasional shop item, and when one does come it is usually worth a lot to thousands of our other readers in far corners of the globe. But once in awhile the mailman brings us a specimen like this, and we wonder if this is still the twentieth century: "Say, did you think I would send in my ideas? Nix—nothing doing. I keep my trade secrets to myself." Now, how much progress do you think that toiling son of Vulcan is making to get out of the rut of ancient methods onto the plane of co-operative effort, where Uncle Samuel's smiling Williams roll freely and easily through the shop door?

Side-lines! Ever hear that term used in connection with a football game? There the sidelines are mighty important, flanking up the principal players, holding them against set-backs from the opposing team, clearing the way for a straight away drive to the goal. How about applying the same principle to your own business? Business is a game—a mighty and a strenuous one, and you owe it to yourself to play it according to the best rules. Take on a few side-lines, fortify your business against a falling off in your shoeing trade or your jobbing business. Take advantage of the many attractive agency propositions on the market for smith shop owners. Add to your regular work one or two of the profitable lines such as oxy-acetylene welding, wood-working, etc. Then you will be prepared for a straight ahead drive for the goal of success and prosperity.

Cut-throating and co-operation, what a difference in the meaning of the two words! In these days, that promise for everyone self-sacrifice and conservation to the extreme, there is no room for the former. Cut-throat price reducing accomplishes nothing. Instead of trying to drive your competitor out of the business by cutting prices to a point where you can hardly make a decent living, go to him and talk over the matter of mutually adopting a scale of prices. Then if a customer comes in, has you figure on a job, and then says, "Oh, I can get that work done for so much by So-and-So," you just gently inform him that he can't. Of course, "seeing is believing", and he'll go there and find out. Then is your chance to win his trade by courtesy, good workmanship and advertising methods,—that in the long run always win, and create in his mind a feeling of sincere respect for you as a business man. Get the idea? Go to it. Co-operate.

And as a last word, will we hear from you before the month is over? How about it readers? How long must we wait for that article or item from you. This is your paper. We want you to have a hand in its publication. You surely have run up against jobs that taxed your ingenuity to solve, and we'll bet a dollar to a doughnut that more than one brother anvil slugger has been up against the same thing—or may encounter it someday. Why not send in an account of it now? Who knows how far that little item will go in lending a helping hand to others! Write us about what kind of work you are handling, what the trade conditions are like in your locality, how the price situation is and how you are meeting it. And if you have a picture of your place—why send that along too.



### SHOPS FROM MANY LANDS

The proverbial smithy under the spreading chestnut is not alone in its glory. Here we see substantial shops from every corner of the globe—underneath the “murmuring pines”, broad shading elms, sunny Southern skies, the blazing desert sun, in the shadow of tall city buildings, in rural, merrie England, far away South Africa, and last, but not least—blarney Ireland.

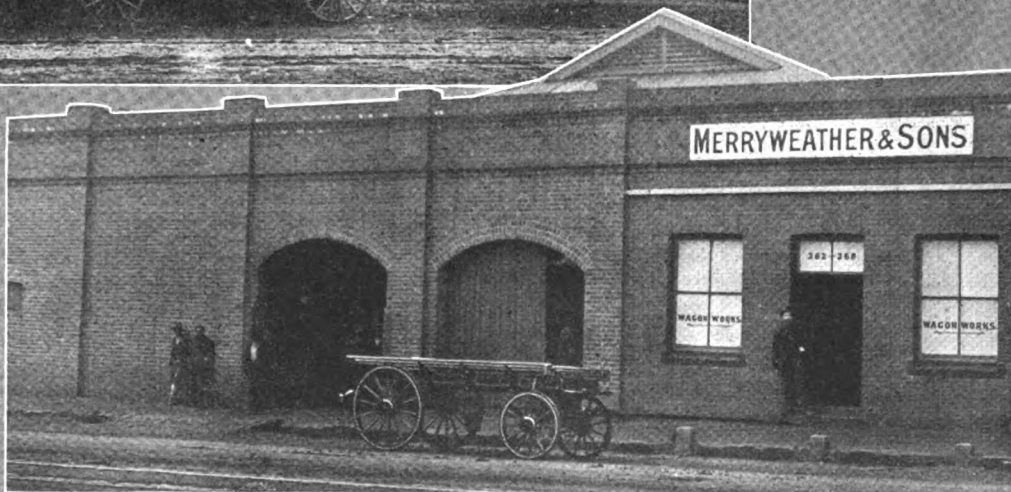
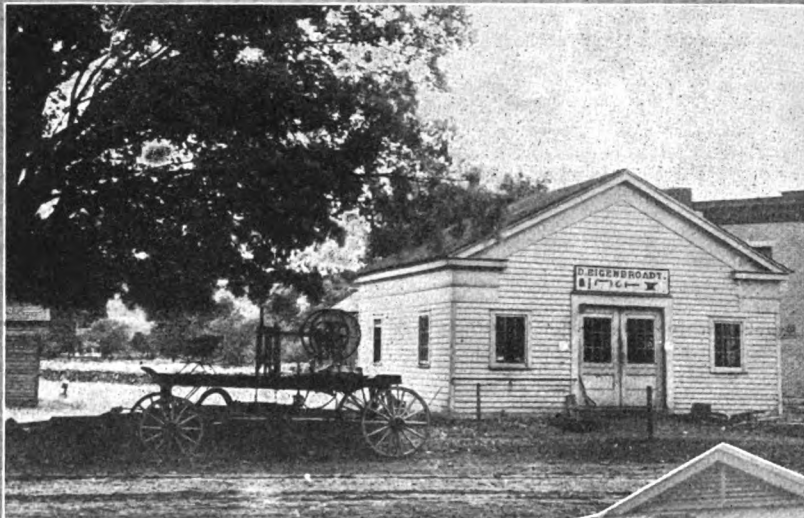
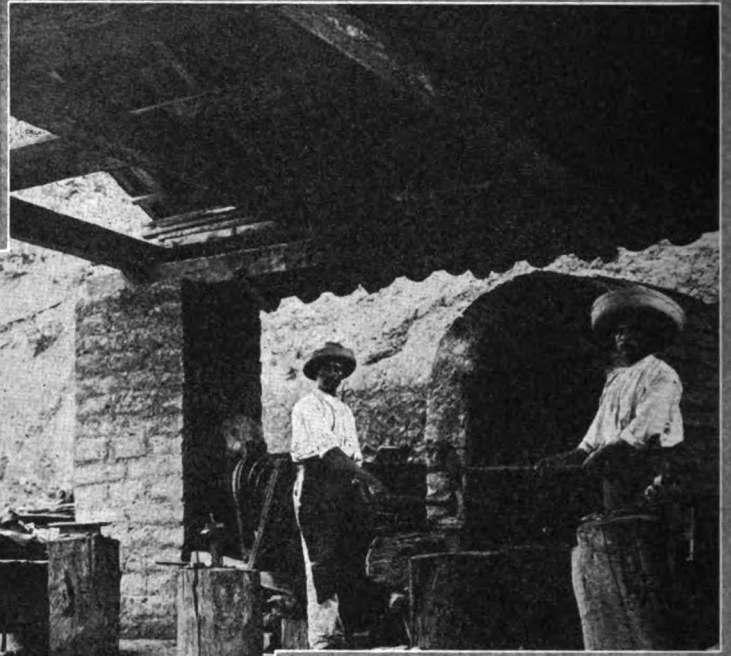



Our Honor Roll

AS GOOD AS A BOND!

That's what one reader says about his long-time subscription. It is an investment that pays for itself over and over again.

A long-time subscription is an investment well worth your thoughtful attention. Read the rates below. Notice how much actual cash you can save—and get busy today.

WHO'S NEXT

Kansas has carried away all honors and is still undefeated champion. Who is ready to step into the ring and try for the title? Utah held it for many months until it got Kansas' goat, when Mr. Krebbel got busy and in one round took the honors for his state.

U. S. and Mexico Canada Other Countries. 2 yrs. .... \$1.60 and save \$.40 ... \$2.00 and save \$.50 ... 10 sh. save 2 sh.

Table with columns: NAME, Subscription Paid to, and dates. Lists subscribers from various states like Kansas, Utah, Texas, etc., with their subscription dates.

Table with columns: NAME, Subscription Paid to, and dates. Lists subscribers from various countries like England, Iowa, Scotland, etc., with their subscription dates.

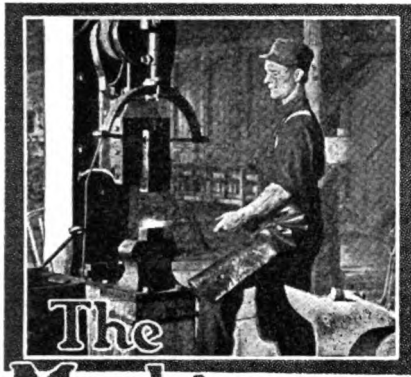

# The Machine and Tool Smith

## Selecting the Lathe

JAMES STEELMAN

There are few additions to the modern shop more profitable as time and labor savers than the engine lathe. It is a machine tool suited to a variety of uses, and rightly chosen in regard to the work which it is intended to perform, becomes an efficient right-hand helper to the machine and tool smith.

In selecting such a lathe for repair work, it is more important to consider whether the lathe can be made to do the hundred and one things that will be required, rather than whether it is fitted with special attachments and devices enabling one to do only some of the things required. For example, the modern lathe is often fitted with special gear arrangements connected with the lead screw, which enable the operator very quickly to have his lathe ready to cut some particular thread. Let it be borne in mind that such provisions imply expenditure of money when making the purchase. It will be wise to consider whether these arrangements are worth their extra cost to the shop that is going to use the lathe. Unless there is prospect of a good deal of thread cutting, the extra money may perhaps be better spent in getting a heavier or a better lathe.

Other things being equal, the heavier the lathe is, the better. Weight is ordinarily required to give steadiness.

The bearings of the spindle should be *wide apart*. Wear will then not affect the precision of the operation of the head as much as would be the case with a short distance between bearings. Furthermore, both bearings should be rather *wide*. The wear is then distributed over a comparatively large surface;

and this tends to reduce the thickness of metal worn away on both spindle and in bearings.

The lathe bed should ordinarily consist of a *single casting*. In general, it will be best to reject consideration of a lathe whose bed consists of two parts bolted together.

The tail stock should have a *long bearing on the ways*. Otherwise, its movement backward and forward may involve inaccuracies.

Back gearing is employed to secure slow speeds. Such speeds are ordinarily used to make heavy cuts and the like. If the work of the lathe is to be confined to light cuts, one may perhaps dispense with back gearing.

The carriage shifts along the bed similarly to the tail stock. Accordingly, its bearings should also be *long* to avoid inaccuracies.

The diameter of the lead screw should be generous, as it has the duty of driving the carriage when screw threads are being cut. It has, therefore, to resist the reaction of the work to the longitudinal cutting operation.

In Fig. 1, we have a typical engine lathe. This machine is able to handle

60 or 72 inches. But this measurement does not give the length of the work that may be put on the lathe. That is indicated by the *distance between centers*. In the present case, the head stock and the tail stock together use up 24 inches, so that the distance between centers is 24, 36 or 48 inches. This lathe is provided with back gearing. By using it, the cone speeds will be made one-seventh what they would be without its use. That is, *the ratio of the back gearing* is 7 to 1. There is a *hole through the spindle* having a diameter of  $\frac{3}{4}$  inch. Such a hole is, at times, of advantage, as it permits a long rod to be run through. This rod may then be mounted on the tail center and held by suitable chucking arrangements at the head stock. Naturally, the maximum diameter of the rod must be less than the diameter of the hole through the spindle. This lathe has, it will be noticed, a lead screw. The diameter is  $\frac{3}{4}$  inch and the number of threads per inch (often incorrectly called the pitch) is 8. The lead screw may be so arranged that with its aid the operator may turn threads ranging from 2 to the inch up to 48 to the inch. On the floor may be seen

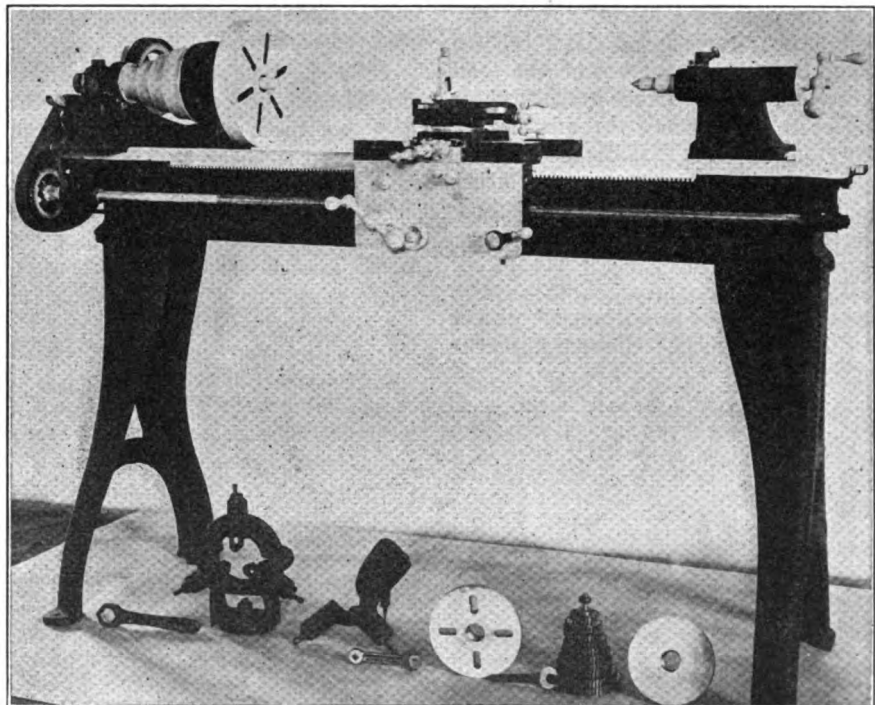

FIG. 1.—A TYPICAL SMALL ENGINE LATHE SUITABLE FOR GENERAL USE IN THE AVERAGE SHOP

work up to  $11\frac{1}{4}$  inches in diameter. That is, it has a  $11\frac{1}{4}$ -inch *swing over the ways*. The carriage can not, however, be used up to this diameter. The *swing over the carriage* is  $6\frac{1}{2}$  inches. The *length of the bed* is 48,

a pile of extra gear wheels. The *cone pulley* has four steps, it will be observed. This means that there are four different speeds obtainable the pulley alone. Combined with the back gearing, there are four



additional speeds. The *cone diameters* range from  $2\frac{3}{4}$  to  $5\frac{3}{4}$  inches. There is a *compound rest* mounted on the carriage. This compound rest may be adjusted so as to direct the tool to

spindle will turn at the rate of 492 revolutions per minute ( $200 \times 2.46$ ). This is the most rapid speed of the lathe. It will be cut down somewhat in practice, because the belt will slip

arrangements are such that either one of these single pulleys may be made to operate the countershaft and consequently the cone pulley. When one is driving the countershaft, however, the other is running loose on it. A usual method of putting one into action and the other out is by means of a long wooden handle reaching down within reach of the lathe operator. One of the single pulleys is connected to its line-shaft pulley by a crossed belt. In this way, it will be turned in the opposite direction to that in which the line shaft rotates. In consequence of the foregoing arrangements, a single shifting of the long wooden handle suffices to reverse the movement of the lathe itself. A steady rest is seen on the floor at the left. The opening in the steady rest is large enough to admit work of  $4\frac{1}{2}$  inches in diameter. The small face plate on the lathe has a diameter of  $6\frac{1}{2}$  inches; that on the floor, of 14 inches.

Lathes that are not to be driven by motors are sometimes made with-

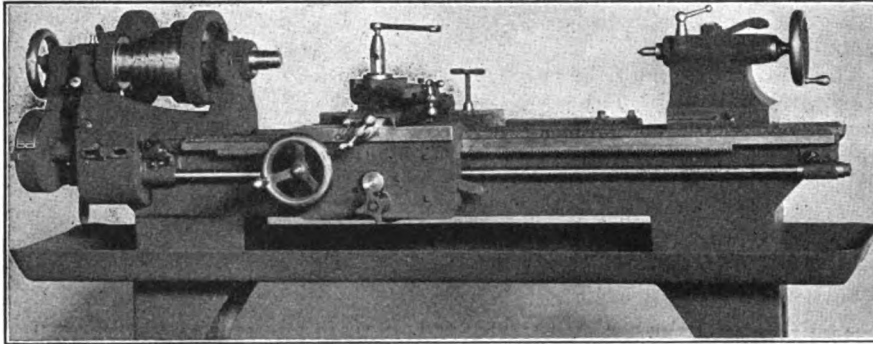

FIG. 2.—ANOTHER SMALL LATHE. NOTE DRIP PAN

the work at various angles. The double handle provides for feeding the tool in the direction of its length.

In Fig. 2, we have another small engine lathe. This machine is rated as an 11-inch lathe, although the actual swing over the bed is really  $12\frac{3}{4}$  inches. The *pan* beneath the bed is useful for keeping the oil drip from the floor and for catching chips, etc. As in the preceding lathe, there are four steps to the cone pulley. The back gearing ratio is 1:9. The hole through the spindle is 1 inch in diameter. The diameter of the lead screw is  $\frac{7}{8}$  inch. There are 8 threads to the inch and screw threads may be cut ranging from 2 to 40 per inch.

In both the pulley driven lathes shown in Figs. 1 and 2, the counter shaft is assumed to run at 200 revolutions per minute. In the case of the lathe in Fig. 2, the smallest step on the cone pulley has a diameter of  $3\frac{1}{4}$  inches. The largest diameter on the counter shaft pulley is 8 inches. Ac-

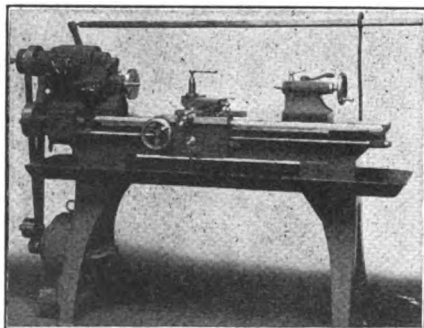

FIG. 3.—THIS TYPE IS MOTOR DRIVEN

ordingly—disregarding slippage of the belt—the spindle will be rotated  $8/3\frac{1}{4}$  times as fast as the countershaft. Dividing 8 by  $3\frac{1}{4}$ , we get 2.46. As the countershaft is assumed to run at 200, we determine that the

more or less. The slowest speed obtainable with the cone pulley is secured by using the smallest step on the countershaft ( $2\frac{1}{4}$  inches) with the largest step (7 inches) on the cone pulley. Dividing  $2\frac{1}{4}$  by 7, we get 0.32. Multiplying 200 by 0.32, we obtain 64. This means that we have 64 turns of the spindle per minute. In reality we will have something less, because of slippage. By throwing into action the back gearing, we should obtain a speed one-ninth as fast, ( $64 \div 9 = 7.11$ ).

In Fig. 3 is shown substantially the same lathe as in Fig. 2. Only here we have a *motor driven* machine. No countershaft is employed. Variations in speed are secured by means of gearing. Eight different speeds are thus obtained. There are three knobs—seen in front of the head case. By turning these and shifting the *shipper rod*—seen at top of the view—the gears within the case are changed and the various speeds obtained. The belt from the motor runs over the driving pulley. Friction mechanism here enables the lathe to be reversed, when that is desirable.

Fig. 4 shows a cone-pulley, back-geared engine lathe, rated as having a 13-inch swing. The swing over bed is really  $14\frac{3}{4}$  inches. This lathe is substantially the same machine as that shown in Fig. 2. It is, however, larger and does not have a pan. On the floor will be seen the countershaft. This will be mounted overhead, with its ends reversed so as to make its cone pulley properly correspond to the cone pulley on the lathe. It will be noted that the countershaft has mounted upon it two single pulleys. These are to be belt-connected to the line shaft near by. The ar-

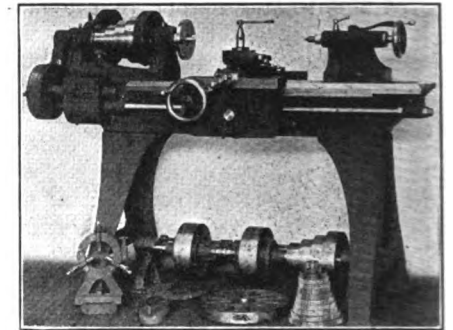

FIG. 4.—A BACK-GEARED TYPE

out a cone pulley. A single pulley is used instead, and the various speeds are obtained by means of gearing. Where gearing is substituted for the cone pulley, the lathe is said to have a *geared head*. Fig. 3 shows a geared head lathe. The machine in Fig. 4 is obtainable with a geared head and single pulley, the latter suited for ordinary driving by a steam-operated belt.

In the lathes shown in Figs. 2, 3 and 4, there is a gear box at the left hand end of the lead screw. Three different changes of the gearing arrangements may be made without opening the box by simply sliding a gear by means of the projecting piece. By substituting other gears, other groups of three may be arranged. This is one of the simplest of the *change gear* devices.

In Fig. 5 is seen a motor driven engine lathe standing in a pan. The motor is here installed in an elevated

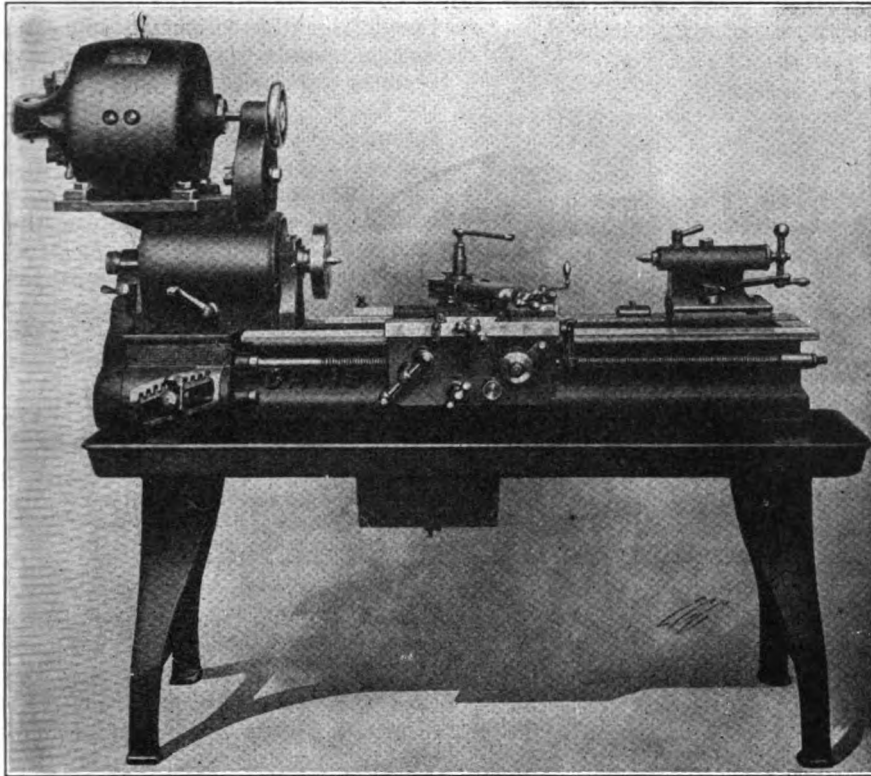

FIG. 5.—A MOTOR DRIVEN LATHE FITTED WITH AN ELABORATE CHANGE GEAR DEVICE

position. Being motor-driven, the lathe naturally has a geared head. This machine is fitted with an elaborate change gear device. Numerous changes of longitudinal feed corresponding to various threads may be made. The compound rest has on its base a system of markings enabling the operator to determine the number of degrees of slant which the tool makes with the axis of the work. This lathe is rated as having a 12-inch swing, although the real swing over the ways is  $12\frac{5}{8}$  inches.

In Fig. 6 is shown a very expensive lathe—too expensive, in fact, to be a profitable investment for any but a large repair shop. However, where the amount of lathe work to be done justifies it, this machine seems to be a highly useful tool. Let it be noted that the face plate extends down into what appears to be a gap in the bed. As it stands, the lathe has a swing of 16 inches. But it is possible to slide the top part of the bed on the right of the face plate to the right. This opens up the gap and enables the full diameter of the face plate to be used. That is, the lathe may be converted from a 16-inch machine into one having a swing of about 32 inches. Shifting the upper part of the bed to the right also results in lengthening the lathe. This machine is a combination of a big and little lathe all in one.

Fig. 7 discloses an engine lathe standing in a pan. There is no lead screw with this machine. The rod extending along the front of the bed is used to drive the carriage, but this is done without the use of threads on

necting belt is not shown in the view. Probably this type of lathe may be built for less money than a machine provided with a lead screw. We should hardly expect, however, to be able to cut screw threads without the aid of a very rigid device like the lead screw geared to the spindle, the device which is usually employed for cutting. On the other hand, we may know beforehand that thread cutting will not be part of the lathe's work. In this case, the belt-connected cone pulleys will probably give us good results. In fact, this arrangement is perhaps quite advantageous for ordinary longitudinal feeding. If a hard spot is in the work encountered by the tool, the belt can yield by slipping.

Fig. 8 shows a lathe of the type seen in Figs. 2, 3 and 4. This one is motor driven, like the machine in Fig. 3. Here, however, we have a lathe provided with arrangements for the feeding of oil. At the left-hand end of the pan, back of the belt which drives the head of the lathe is the pump which forces the oil through the piping to different parts of the machine. The reservoir is located beneath the bed and has a rounded bottom.

Figs. 9 and 10 illustrate, either of them, 14 and 16 inch lathes. Both machines are said to be extensively used in garage work. As will be ob-

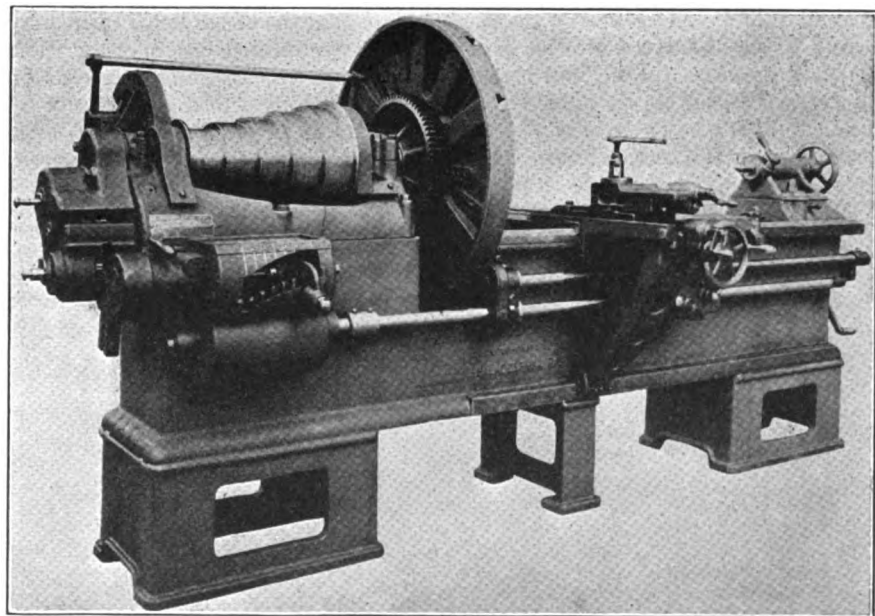

FIG. 6.—A SUBSTANTIAL TYPE FOR THE BIG REPAIR SHOP. OBSERVE THE GAP IN THE BED

the rod. Various longitudinal feeds are obtained by using various combinations of the little cone pulleys seen at the extreme left. The con-

served, one view shows a lathe with cone-pulley drive. The other exhibits a motor-driven machine. Steady rests are seen mounted in position in

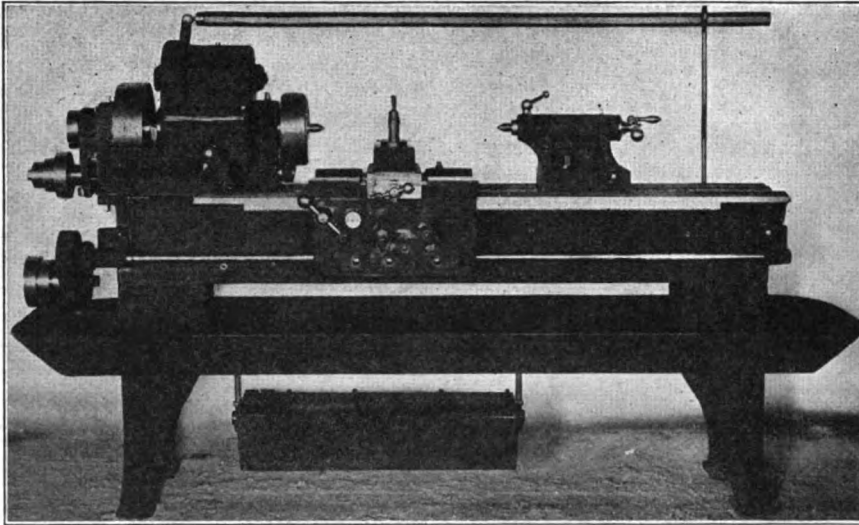

FIG. 7.—THIS LATHE IS NOT PROVIDED WITH A LEAD SCREW; HENCE IS LIMITED IN ITS OPERATIONS, BUT IS CONSIDERABLY CHEAPER BECAUSE OF THIS

both cases. The oiling of the spindle is done by hand. The remaining important bearings are supplied by an oiling system by which the oil is fed by gravity. Threads may be cut in a range from 2 to 112 threads per inch. The changes of threads are provided by the quick change gear devices arranged at the left-hand end of the machines. A *follow rest* is mounted on the carriage in both cases. This device provides support which is always close up to the tool.

Fig. 11 shows a cone-pulley, engine lathe of 13-inch swing. It will be noted that there are two rods extending along the front of the bed. One of these has a thread and is the lead screw. The other is a *feed rod* similar to that shown in Fig. 7. It carries or shifts the carriage and

consequently the tool longitudinally. Ordinarily this feed-rod will be driven by the small cone pulley at its left end, this in turn being driven by a still smaller cone pulley above it. The connecting belt does not appear in the picture. However, this feed rod may be driven, when desired, by the screw cutting gears. The advantage of this consists in the possibility of thus obtaining a very fine and very regular longitudinal feed.

As to the *lengths* of lathes. Prospective purchasers may bear in mind, perhaps to their profit, that various lengths of the same lathe may often be obtained by making their wishes known. If one wishes to do unusually long work, it may not be necessary to buy a lathe with a large swing to get the length desired.

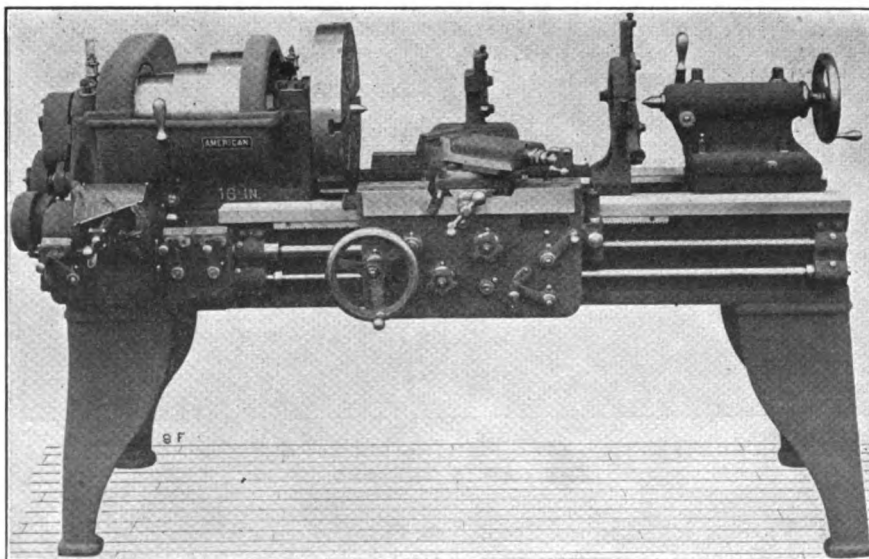

FIG. 9.—A TYPE USED WIDELY IN GARAGES. THIS TYPE WILL CUT THREADS RANGING FROM 2 TO 112 THREADS

Special lengths will often cause no serious trouble to the manufacturer, because ordinarily but little besides the bed will require to be made differently.

Fig. 12 shows another lathe, fitted like that shown in Fig. 11, with both a lead screw and a longitudinal feed rod. This is a 16-inch machine. There are 40 changes possible in the quick change gear arrangements for thread cutting.

### Sturdy Knight of the Forge Stands on His Rights and Defies a Railroad Com- pany, Corporation Law- yers and Courts.

Although excavations for the big new N. O. T. terminal are being made only a few feet from his blacksmith shop in Akron, Ohio, and the work has closed the front entrance to his shop so he has been forced to build a temporary bridge across the

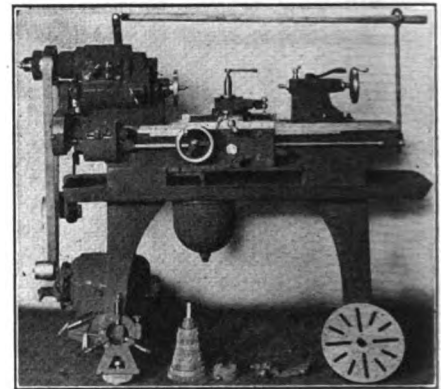

FIG. 8.—AN ENGINE LATHE PROVIDED WITH AUTOMATIC OIL FEED

old mill race to save himself from total isolation, William Mee still plies his trade.

Corporations have tried to buy him out but they haven't offered him his price. They've tried to force him out but so far he has beaten them at this game.

His little shop is perched on a pinnacle that looks as if it would totter every time an impatient horse gives a loud snort. But Mee says his shop is going to stand.

The first trouble Mee had in court came last December when the Akron Canal & Hydraulic Co. asserted they owned the right of way for the mill race which runs by the side of Mee's shop and that Mee's place was on their right of way. The company lost the suit.

Recently the N. O. T. began a land



appropriation suit, claiming that the shop interferes with their plans for a terminal station. Mee has answered this action by asserting that the building is not to be a terminal station but just an ordinary freight house and is therefore not a public utility.

Mee says he turned down an offer of \$10,000 from the N. O. T. for his property because "they'll have to come stronger if they want the lot."

### Organize to Care for Army Animals

To care for the ailing and wounded animals of the American Army the American Red Star Animal Relief has been organized, under the auspices of the American Humane Association. Headquarters have been opened and arrangements are being perfected to aid the veterinary corps of the Regular Army as soon as the need arises.

Last May Secretary of War, Newton D. Baker, wrote to the American Humane Association, with headquarters at Albany, in part, as follows:

"The function of the American Red Cross is to assist the Government in caring for the human sick and wounded in its armies. The American Humane Association could very well function in a similar manner in assisting the Government in caring for the sick and wounded animals in its armies. Such assistance would be very gratefully received by the War Department."

The association accepted the task and since then has been busily engaged in arranging for the development of the or-

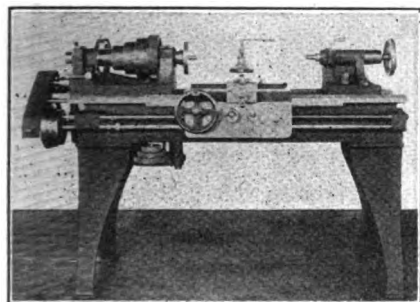

FIG. 11—EQUIPPED TO PROVIDE A VERY FINE AND REGULAR LONGITUDINAL FEED

ganization and raising funds to provide the necessary supplies.

The name, the American Red Star Animal Relief, has been taken to designate the service.

#### Lessons Taught on the Border

The need of the relief organization was made more imperative as shown by events when the National Guard was mobilized last Fall at the Mexican border. In that connection the new organization has made the following statement:

"The need of an organization like the American Red Star Animal Relief was well illustrated during the recent difficulty with Mexico, when some 70,000 additional horses were suddenly shipped to the border.

"The small veterinary corps in the Regular Army, which consists of less than

100 men, without enlisted personnel, was physically unable to care for all the animals demanding attention. Many of the horses purchased by the Government contracted shipping fever or some other contagious disease at the horse market and communicated the disease to the animals already in service.

"It is said that in some of the camps where horses were kept fully 90 per cent. of the animals were incapacitated for

with many leading citizens, are giving it the most loyal backing.

"The Red Star has started a volunteer corps in which it is recruiting veterinarians of approved veterinary colleges, and a large number of experienced blacksmiths and stable hands.

"Branches of the Red Star have been organized in New York, Boston, San Francisco, Chicago, Portland, Ore., and other points."

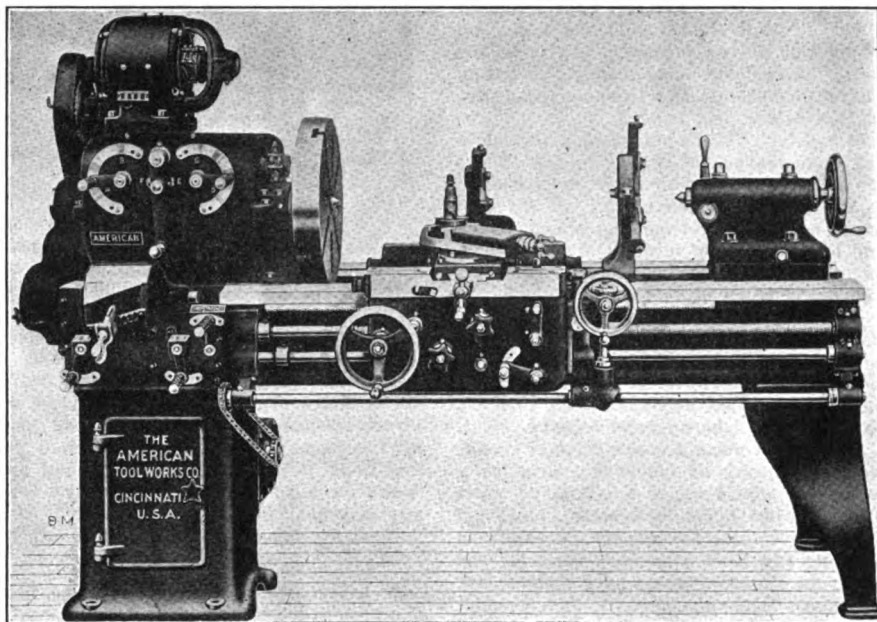

FIG. 10—MOTOR DRIVEN AND USEFUL FOR HEAVY JOBS

work at one time. Had there then been a large need for cavalry service it would have been impossible to put more than 10 per cent. of the men in the field.

"At one point on the border more than five or six thousand animals were kept within a radius of 10 miles, yet no ambulances were provided to transport the sick and injured horses to the veterinary hospitals.

"Many of the camps were for several months without shelters of any kind for the horses against the heat of the day or the cold of the night. Veterinary supplies and hospitals were slowly and often inadequately furnished.

#### Million Horses Sent to Europe

"The importance of conserving the animals available for army service is more thoroughly appreciated when one realizes that nearly a million animals, worth approximately \$200,000,000, have been sent to Europe for war purposes.

"Reports are coming from all of the large horse centers that dealers are unable at the present time to fill all the orders which they have for animals for his export trade. Our own Government purchasing agents find it difficult to secure animals of the right type.

"Because of this scarcity the conservation and the lengthening of life of all such animals becomes a most important consideration. These animals cannot be replaced from natural sources inside of four years.

"The movement in this country has not only the very earnest support of prominent Army Officers in the United States service but also that of the American Veterinary Medical Association. Governors and public officials are on its honorary council, and,

### Character In Business

It is a truism to say that character goes far in business. A blacksmith in a nearby town once could borrow all the money he needed because it was said that he would never borrow more than he could pay. Pierpont Morgan, not long before his death, testified at Washington that character was the basis on which he extended credit, and he illustrated it by saying that he lent \$1,000,000 to a man with nothing but good character, while he refused to have any dealings with men of large financial resources, but whose character was doubtful. A New York lawyer, who has had much experience in collecting debts, says that if all laws for the collec-

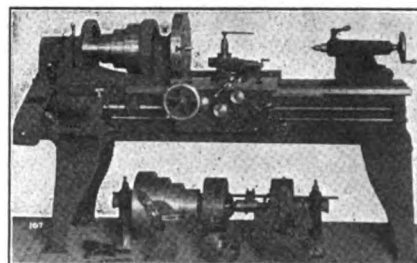

FIG. 12—FORTY CHANGES IN THE QUICK CHANGE GEAR ARRANGEMENTS ARE POSSIBLE WITH THIS MACHINE

tion of debts were wiped out, the general situation would be improved. This was a favorite insistence of Alexander H. Stephens. He urged that all debts should be like gambling debts—debts of honor—and





that where a man had not honor sufficient enough to obtain it, he did not deserve it, and that in the long run there would be less delinquency than there was under laws which allowed collection for debt.

There has been progress in business in a general way toward this. It used to be that a man had to get one or more indorsers on his note. That is, the money was really lent on the credit of the indorsers. Now a man gets money on his own worth or he does not get it at all. But there remains the full application of the idea, that debt should be based on honor and not on property. As it is, the collection of debts is often only a delusion. There are no statistics to show what proportion of the debt sued for really goes to the creditor. The winning of a suit does not mean repayment by any means. There are lawyers' fees, which are proportioned to the amount of the claim; all sorts of costs, and loss of time and much worry and loss of peace of mind. Only those who have had the experience know what a hazardous thing it is to have to sue for a debt. It is not at all unlikely that as the borrowing of money has got to the point of the point of the character and worth of the borrower, so in time its payment will rest so, and that if he does not pay there shall be no legal remedy.

This would mean a contraction of credit, but the forcing of business nearer to a cash basis would not be a calamity; while placing it on honor and clear knowledge of character and the reality of assets in the long run have a greater effect for the better in elevating the whole standard of business.—Exchange.



## Benton's Recipe Book

Iron or Steel—which? If you are ever puzzled and want to find out in a hurry, try this simple test: dip a stick of wood into nitric acid and touch the metal with it and wash off quickly with water. If iron, a light or a blue stain will appear; if steel, the stain will be black. Of course, be careful not to get any acid on the hands.

Compounds for Welding have been given almost without number in these columns. Here is one recommended for welding steel or iron: Mix ten parts of borax, one part purissiate of potash, one part sal ammoniac and about one-third of one part of bright, clean, iron filings. This mixture is reduced to a fine powder in a mortar. Then add enough water to make it about the consistency of heavy mud. Now place it over a wood fire and stir it until a material having the appearance of pumice stone is produced. This is pulverized to a fine dust and is used by sprinkling over the metals when they are at a welding heat.



## Queries—Answers—Notes

Likes the Articles on Automobiles—I would like you to discontinue.....'s subscription to THE AMERICAN BLACKSMITH, as I am taking it in his place. I cannot recommend too highly your articles on the Automobile Repairman, care of tires, etc. It's just the stuff we want. Write more of it. I am going to get all former issues of the magazine and have all the pages of the Auto Repairman put into book form, as I have not found any books on auto repairing that have come any way near it.

Wishing you more success, I remain,  
RAY FETZNER, New York.

A Letter from Michigan—I have been thinking for some time about writing to Our Journal, but like many other things have spent more time thinking than writing.

Our long winter is past, and we are glad to welcome spring as it livens up our business, bringing along a lot of general repairing of farm implements, wagon buggies, etc., and some auto work. Our shoeing business is better in summer than winter, as there is no winter teaming here. Now that the timber is gone and cement blocks have taken the place of stone, farm teams are idle all winter. The spring shoeing is harder, for the feet are allowed to grow all out of shape and proportion of what they should be. A good many of the heavier horses are flat footed and they get in such shape that it is quite a job to get nails high enough to hold good.

Shoers in the larger towns and cities are shoeing very heavy and calking extremely high which seems to add to our flat footed troubles a good deal. We use a good many plates on these farm horses with better success than calks, and we think it helps to overcome the tendency to drop soles and contraction of the feet. Some of our shoeing is on horses working on the road at road building, drawing gravel and heavy hauling. These we have to calk. We use broad calks and not high, which seems to give better satisfaction than the higher calks.

We think our general repair business is worth more to us than horse shoeing at the present prices of 25c and 50c for shoeing. A little more dry weather and tire setting will be the order of the day. If our buggy manufacturers would use only one-half the tire bolts they do and give their wheels 1/8 to 3/16 of an inch dish we would have less felloe-bound wheels to contend with. A tire can expand but little before it takes the rim with it and that means the rim pulled off of Sarven wheels, and spokes

out of the hub in wood hub wheels.

With more room between bolts the tire could expand without pulling the rim off. We did not use to have half the trouble with wheels when bolted at every other spoke. Experience is a pretty good teacher in regard to such things, and 50 years behind an anvil has given me some experience that would give present-day methods a good run for their money in changing my mind. Many things have to be done differently today than when we used to make all of our own shoes, nails, calks, bolts and nuts by hand. Times are moving too fast to wait for work to be done the old way.

With best wishes to the trade.  
R. N. NORRON, Michigan.

Mr. Murphree Tells of His Experience in Welding—I guess it is about time I was writing you again as I have not written for some time. But I have not failed to note the interesting things in Our Journal. I don't know how I could get along without it. It is interesting as well as instructive. I have been especially interested in the articles on acetylene welding as I have had a welding machine myself for nearly two years, I have gotten to the point now where I can weld almost anything that breaks. I tell my wife sometimes that I have been thinking of writing the government and telling them I wanted to weld the crack in the old Liberty Bell. Some blow, eh!

During February of this year I handled an exceedingly difficult job on an old

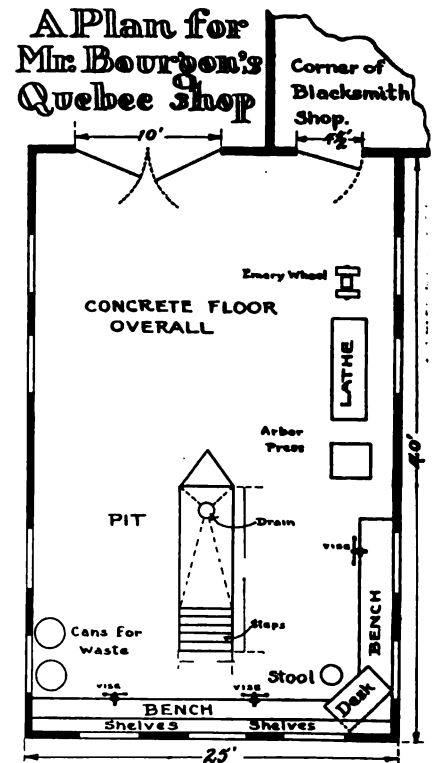

No. 40 Maxwell engine. The connecting rod had worked loose and torn up one whole side of the crank case and ripped off the top of one cylinder water jacket. The crank case was aluminum and was both thick and thin in places which made it more difficult to weld. I welded the job perfectly and worked the whole engine over, getting about \$8.00 out of the job, at the same time saving my customer some \$25.00 as the old model repairs come high. I am always taking pictures of broken



jobs before welding but somehow I don't get many good ones. I guess I am not as good at photographing as welding. However, I am enclosing with this letter one of a monster tractor flywheel which weighed about a ton or more and was pretty badly broken at the hub and one spoke missing. This picture shows it just before we began preheating. I have a heating furnace in the ground behind the wheel. Two of us were 9 hours heating and welding, and it took nearly 100 hours for it to

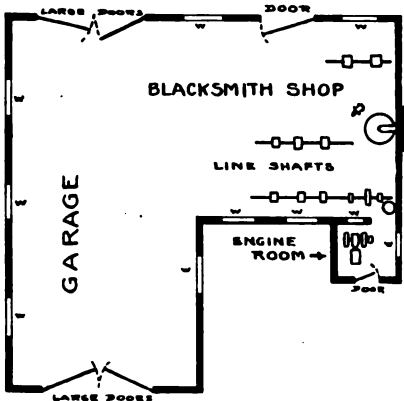

MR. D. W. MURPHREE'S SHOP AT MEDICINE MOUND, TEXAS

cool in cinders. Of course, we handled it with hooks and tackle outfit.

Now this letter is a little long but I must tell you about my shop. It is too small for our business, but I am not able yet to rebuild. It is size 20x56x20x36. Perhaps you won't understand these figures so I will give you a diagram in rough which shows the location of my engine, line shafts, etc. As space will not admit I will not try to name everything, but I will say that I have my shop well equipped and have a good business, both in the blacksmith shop and garage. We repair anything that we think can be repaired, a good many things that others must think can be welded when nothing else works, for they come to us with all kinds of machinery from neighboring towns.

D. W. MURPHREE, Medicine Mound, Texas.

**Mr. Erickson Describes His Shop**—I am enclosing a sketch of the shop I have just built, and believe it describes everything about as I have it arranged.

My shop is 48 by 24 feet over all, with concrete floor, and 9 feet, 10 inches high.

I handle gas welding, general machine shop work and some forging; but do not touch any plow work, shoeing or wagon work, leaving that to the general blacksmith. There has been plenty of work this past winter; all myself and a helper could handle and keeping us busy every minute. There has been a good deal of gas engine work—as many as six engines being in the shop at one time. Occasionally we weld or repair broken parts of automobiles, but do no general auto work or overhauling.

Collections are a problem here as I suppose nearly everywhere else. But I find a good deal of help from trade papers, eight of which I take.

J. E. ERICKSON, Minnesota.

**Some New Jersey Prices**—I have been a reader of this good Journal for about two years, and it is very interesting to read the articles in regard to price raising.

I have always been in favor of good prices, but owing to the fact that I had a competitor that was not so inclined, I was somewhat handicapped in this respect. But now that he has quit the business, I am in a position to charge a living price for work. Until June, 1916, the price of shoeing horses here with plain shoes was \$1.25 per set of four, shoes with heel and toe calks, \$1.60 per set of four, and re-setting, \$.80. So I went to my competitor and tried to talk him into raising prices, but he would give me no satisfaction whatever, I then raised mine to \$1.50, \$1.75 and \$1.00, and in about a week he fell in line with me and shortly after I raised to \$1.70, \$2.00 and \$1.20; but he never raised to that and in less than two weeks afterward he quit the business. I then raised to \$2.00 plain, \$2.50 toes and heels, and \$1.40 reset.

But I was not satisfied to stop right there, for some of my brother craftsmen in this county were still shoeing horses for \$1.50. So I got in touch with the state organizer of The Master Horseshoers National Protective Association, and with what little assistance I could give we were able to organize a local association and now we are all getting the same prices and charge enough to keep up with the rising costs of materials.

In regard to charging for iron work, I find the most accurate way is to weigh the material used, and charge so much an hour for the time. Owing to the fact that material varies in prices, I charge 8c to 10c per pound, and add 60c an hour for my time.

I have worked at the trade eleven years and have been in business four, and my experience has been this: that when you

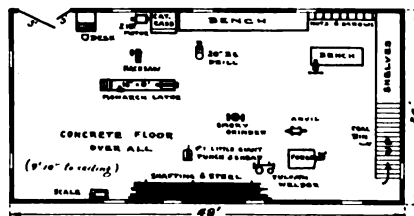

MR. J. E. ERICKSON'S MINNESOTA MACHINE SHOP

find a man who wants to work cheap there is something wrong with him or his work.

My advice is: do good work and charge a good price and you will find that you will last longer and wear better with the people than the "cheap skate."

H. R. JOSEPH, New Jersey.

**A Correction**—In the monthly issue of THE AMERICAN BLACKSMITH, Vol. 16, No. 6 (Dated March, 1917,) I find an article on Motor Knocks, which drew my attention from the mere fact that I have listened to and remedied many such knocks myself having had considerable experience with internal combustion motors of vehicles, stationary and marine types, ranging in power from 2 to 500 horse.

On page 156 of the above mentioned article, we find a brief treatise on valve adjustment, or at least the adjustment of valve tappets. It strikes me that the paper gages mentioned might be rather misleading, to the novice especially, and the figure .0005" is certainly an error. Perhaps it was intended to read five thousandths (.005") which would be better, though even this clearance is rather

slight, and I may say in my experience, hardly sufficient for the average vehicle motor in present day use. Where one motor may be properly timed with a .005" clearance between tappet and valve stem, (always using gage when cam is turned

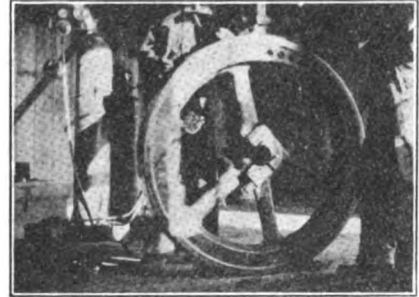

A BIG CASTING SUCCESSFULLY WELDED IN MR MURPHREE'S SHOP

clear of roll at bottom of tappet.) Another may require twice as much (.010") and still another (especially in old style machines) 3 times as much as the first or approximately 1/64."

The danger with too close an adjustment is that the exhaust valve will not close completely before the intake valves open. This is a frequent cause of difficulty in starting; heavy carbon production within cylinder, missing ad backfiring, and of course lack of power.

'Tis well to see that the exhaust valve is properly seated and that the crank has a movement of about 5 degrees before the intake valve starts to open.

Though I love the forge and anvil dearly, I am not worthy to be called a practical blacksmith. This is the first opportunity I have had of reading your magazine, and I wish to pay you something of tribute, inasmuch as I have found it decidedly interesting and instructive.

Wishing you every success,

H. B. TINDAL, Canada.

Mgr., Morrisburg Tack Mfg. Co., Ltd.

**Editor's Note:** Mr. Tindal is right. No doubt the original figure was a mis-print as there is very little difference in the appearance of the figures, .0005 and .005, and the error could have been easily overlooked. Readers will note what Mr. White says on valve adjustment in his article on "The Detection and Location of Motor Troubles" in the May issue. Mr. White discusses the same thing, and states figures that agree with Mr. Tindal's.

**Welding Pipe in a Tunnel**—This has to do with how we welded a large section of pipe in the government power plant tunnel at Mt. Ranier, Md.

We had the pipe cut at the mill so about 1/16 of an inch on the square end of each section was left straight, the other end being beveled so the heat could be applied to the bottom of the metal.

We provided iron trestles with rollers on them to put the pipes in as the racks are 30 inches apart and the pipes about 20 inches long. We would weld up 250 inches of pipe in one piece and leave an opening for an expansion joint or anchor, so the longest pieces of pipe we had to handle were 250 inches. A boy with chain tongs easily turned this, while an operator was welding. He "tacked" the pipe in three places and then started at the fourth place and went around without stopping. As he got to the tacked places he would cut them



out or melt them so there would be no strain on account of them. It took about one-half an hour to do the weld, as they wanted the metal piled up well. I thought that was a mistake; it certainly cost more.

The pipe on the job was tested to 600 lbs. cold water pressure. In our shop we have made every kind of tests that government inspectors have been able to think of and all have proven far superior to any other kind of joint and about 15 times cheaper than the "Vanstone joint," which is the only one that could be, or that would be used on a high pressure, first class job. A man and one helper with this system can weld about 7 welds a day on 12-inch pipe at a cost for all material and labor of about \$3.00 a joint. The welder gets \$5.00 a day (8 hours), the helper \$2.40. The gas

### American Horses in the War

Nearly a million horses and more than a quarter of a million mules is the export record of the United States in the thirty-four months since the beginning of the war. A compilation by the National City Bank of New York made on receipt of the reports of the great mortality among American horses in the war zone shows that the number of horses exported from the beginning of August 1914, to the present time is in round numbers 920,000 and of mules 330,000. The stated value of the horses exported was \$194,000,000 and of the mules \$66,000,000.

The fact that this is "not a cavalry war" and that automobiles, motorcycles, flying machines and observation balloons are performing much of the service formerly required of the horse in war time, does not seem to have checked the demand for American saddle and draft animals. In the first year of the war the number of horses and mules sent out of the country was in round numbers 375,000, in the second year 470,000, and in the third year, which ends with next month, will approximate 450,000. For the fiscal year ending with the month of June 1915, which is nearly identical with the first war year, the number of horses exported was 289,340, in the next year 357,553, and in the nine months of the present fiscal year, for which official figures are available, 226,839, suggesting that the total for the fiscal year which ends this month will approximate 300,000. This suggests a slight decline in the number of horses now being exported, and the suggestion is supported by the fact that the official figures of the very latest month available, March, are about 30 per cent below those of the same month last year.

Whatever reduction is occurring in the number of horses being exported is, however, being made up by the increase in the number of mules sent abroad. They are steadily increasing year by year and up to the very last month for which a record is available, the number of mules exported in the fiscal year ending with June 1915, was 65,788, in the next year 111,915 and in the year which ends with the present month will approximate 160,000.

Most of the horses sent to the war go direct to France, and this is also true as to the mules.



## The Automobile Repairman

### The Care of Tires\*—4 Helpful Hints for the Automobile Repairman

Running a tire, deflated, for any great distance is harmful and inexcusable. A soft or flat tire on a front wheel can always be noticed by the difficulty in steering the car in a straight course; the steering wheel naturally favors the side of the flat or soft tire. If on a rear wheel, pounding and bumping will be noticeable. Demountable and Quick Detachable rims make it possible to change tires very quickly but even if not so equipped, it is wise to stop and give the tires attention when needed. Damage to the side walls, beads, fabric inside, also the inner tube, usually makes it difficult to execute practical repairs. A rear tire ridden deflated very far may result in damage to the differential of the car.

Rough streets tempt one to drive in car tracks. It is more comfortable for the passengers and may be

\*Courtesy Firestone Tire & Rubber Co.

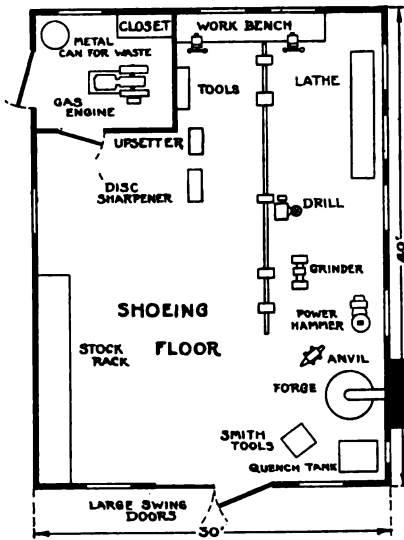

A SHOP PLAN FOR MR. LACKENAUER OF ALBERTA, CANADA

used is Prestolite in cylinders and oxygen from a local company. We use the Davis Bournoville outfit for cutting, we use carbo-hydrogen which is much better and cheaper than acetylene.

There were over two miles of this tunnel and a great deal of terracotta pipe buried in the ground. The tunnel has two steam pipes throughout its length and one or two return pipes, one varying from 12 inches to 5 inches and the other from 4 inches and smaller. Of course, all the headers, nozzles and such in the plant were to be welded. Connections to valves and fittings were made with Vanstone joints which I made using the Hydraulic press to make them with. It is a 50-ton press with accumulator. I think a similar press could be made for about \$400.00. This cost more as there was a lot of experimenting carried on before hand to get just what we wanted.

The writer belonged to a Blacksmiths' Union before he undertook this job, but had to join the Steamfitters' Union, as the American Federation had turned over this work to them. Now the blacksmiths are going to kick him out of their Union and when he's through with this job and gets into blacksmithing again, the Steamfitters will probably kick him out of that too!

R. E. STEPHENSON, Maryland.

"Write for Catalog"—do you know how much valuable information is yours, free for the asking? Write the advertisers and find out.

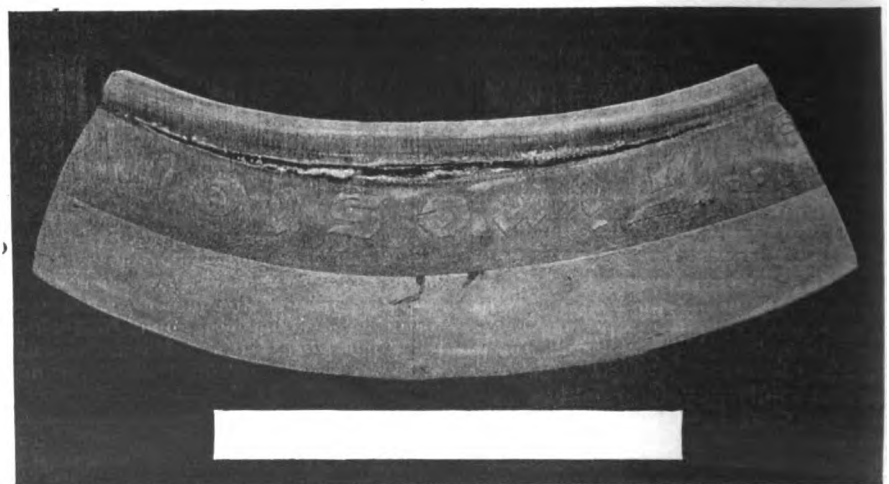

THE EFFECTS OF RIM CUTTING. MAY BE CAUSED BY RUNNING ON DEFLATED TIRE, IRREGULARITIES OF RIM, OR MISAPPLICATION OF SAME

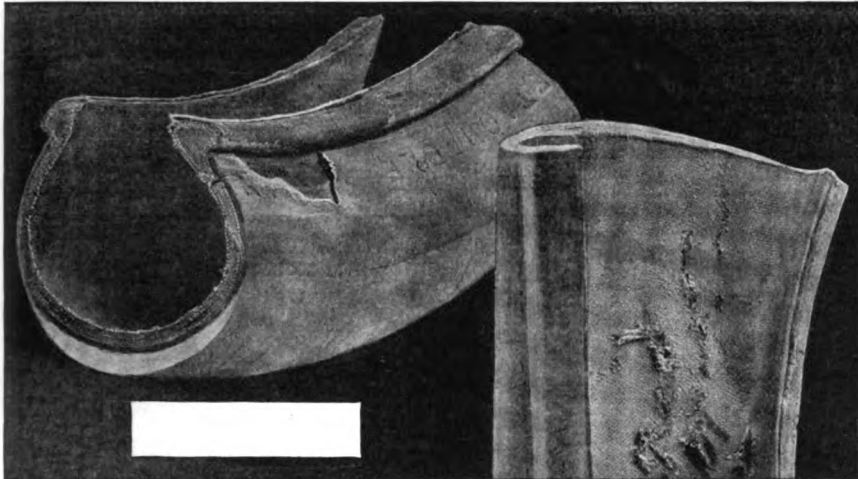

NOTICE CHAFED CONDITION OF BEADS, BROKEN SIDE WALL, AND BROKEN CONDITION OF FABRIC

economy to protect the car, at times, from bumps and unusual vibration by running in car tracks, rather than over rough, cobblestone pavements, and the tires won't be injured noticeably by doing this occasionally—it is the continued practice that shortens the mileage.

Quite often the pavement along inside edges of rails is very rough and may result in cuts to the rubber and bruises to the fabric. Driving over street car track switches at the pointed frogs may cut the tires seriously.

Rails on hills are to be avoided as much as possible as they usually have sharp, thin splinters on the edges, which are liable to cut or puncture the tires.

Be careful when driving on wet rails; quick twisting of the front wheels may result in accident from rear of car skidding sidewise when leaving rails.

Edges of the rails wear away the tread rubber and cause a sharp

bending action of the fabric, which will usually develop breaks inside. It is just a matter of time until the rubber cover loosens underneath and the fabric weakens from moisture and decay. Later, an unusual

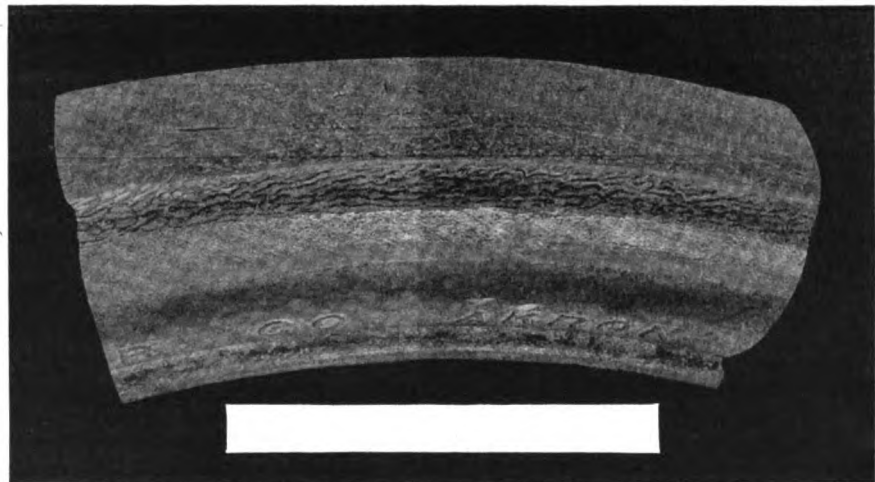

IT ISN'T THE OCCASIONAL RUNNING IN CAR TRACKS THAT INJURES A TIRE, BUT IF DONE CONSTANTLY IT WILL SHORTEN THE LIFE OF ANY TIRE

bump or shock may result in a blow out while running on a perfectly smooth street or road. It is careless, indeed, to spoil a tire in this manner when possible to secure so much more mileage from it, if used correctly, of if reversed on the wheel, i. e., the worn side turned toward car. A competent workman can make satisfactory repairs if only the tread rubber be worn and the tire has not been neglected too long.

Excessive wear to the tread of a tire is usually attributed to fault in alignment of wheels and the real cause is not, therefore, always discovered, even when the car has been inspected by a mechanic.

Investigate the condition of wheels

by proceeding as follows:

*First*—Turn steering wheel so that either one of the front tires will be parallel with the rear tire on the same side of car. The use of a steel tape or straight edge will quickly disclose any irregularity in the alignment of the front wheels in relation to the rear wheels.

*Second*—Because of the tendency of the front wheels to spread under the driving force, it is the practice of car manufacturers to set the front wheels at a toe-in of from  $\frac{3}{8}$ " to  $\frac{1}{2}$ ". This allows from  $\frac{3}{16}$ " to  $\frac{4}{16}$ " toe-in for each front wheel. This toe-in is practically taken out by the action of the car on the road—under momentum the wheels will be approximately parallel.

*Third*—When the front wheels toe-in too much, the cause may be a bent axle, bent steering knuckles, or other injury, but usually is a result of connecting rod to steering knuckles being too long. The connecting rod is threaded at both ends

where fitted to steering knuckles and the remedy is to shorten rod until position of wheels is correct.

*Fourth*—When the front wheels toe outward, it may be due to injuries, but usually is caused by connecting rod to steering knuckles being too short. This can be remedied by lengthening rod until position of wheels is correct.

To Check Alignment of Front Wheels

*Fifth*—Check up front wheels by getting the exact measurement between wood felloes (inside) and directly in front of axle. A stair tread extension rule can be procured from any local hardware store at a nominal cost and is very satisfactory for this purpose. The measurement

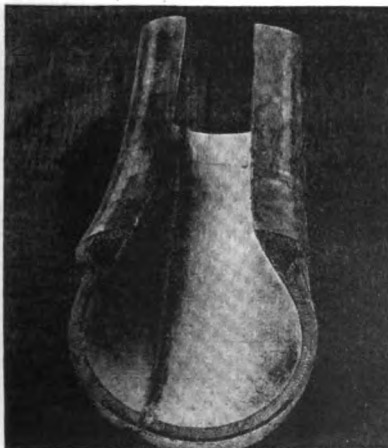

FABRIC BROKEN FROM SHARP BENDING ACTION CAUSED BY EDGE OF RAILS

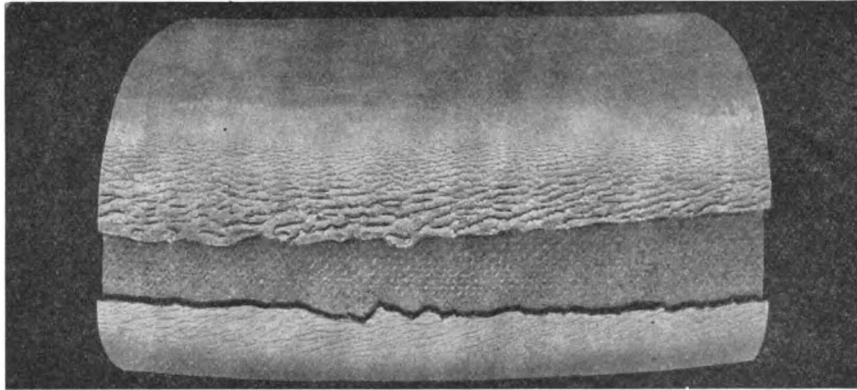

**WHEEL IRREGULARITIES**

The extreme roughness of the rubber shows the wheel to have been in very bad condition, the tread having worn through to the breaker fabric in a very short time. This damage to the tread caused no particular strain or injury to the fabric body and the tire could have been put in practically as good condition as when new by the application of a new tread

between wood felloes (inside), and back of axle should not be greater than 3/8" to 1/2", as compared with the measurement taken in front of axle.

**To Check Alignment of Rear Wheels**

*Sixth*—The measurements between wood felloes of rear wheels should be the same in front and behind axles.

**Method of Checking Each Wheel Separately**

*Seventh*—Jack up each wheel and place a stationary point almost against wood felloe, next revolving the wheel to determine if the distance between the stationary point and the wood felloe is the same at all points around the wheel. If the wood felloe rubs at some point around and not at other places it may be due to a slight variation in the wood felloe, but it will usually result from the wheel not running true.

**Camber of Front Wheels**

*Eighth*—The object of cambering front wheels is to bring the points of

contact of the tire tread with the road as nearly under the steering knuckle pivots as possible, this being the position for easiest steering and

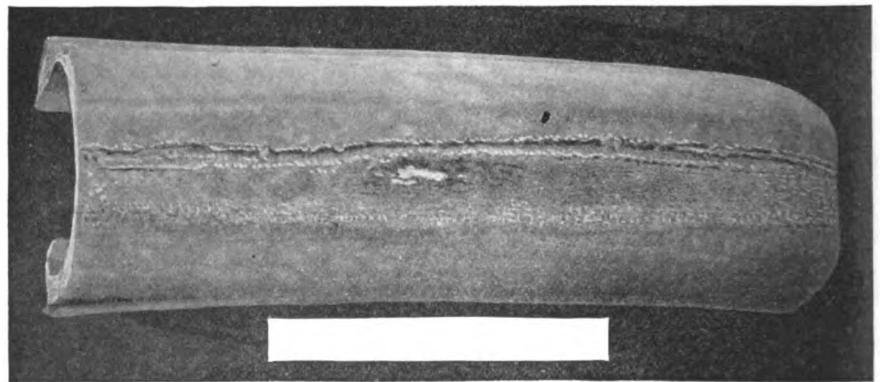

**WHEEL IRREGULARITIES**

for turning curves. The allowance varies from 16/16" to 1 3/4" and is governed by the height of wheels.

*Ninth*—Excessive wear to the tire treads does not always indicate irregular alignment of wheels. It may

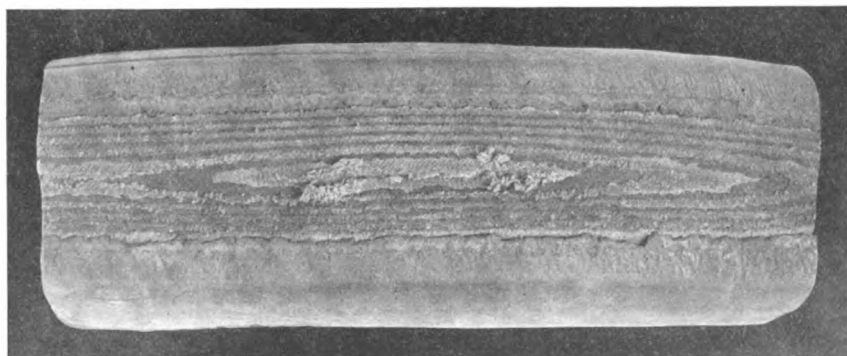

**WHEEL IRREGULARITIES**

Note the sloughed and ground-off appearance of the rubber in this illustration—about the same effect as having been rubbed with a rasp file. Ordinarily the wear is more pronounced in one, two, or three places on the tread—at points where the wheel shifts and wabbles most

often be traced to a loose or worn hub disk, loose bearings, the tight adjustment of one or more brake drums, severe application of brakes, slightly bent hub spindles, etc.

**Hot Weather Rules for Horses.**

1. Load lightly, and drive slowly.
2. Stop in the shade if possible.
3. Water your horse as often as possible. So long as a horse is working, water in small quantities will not hurt him. But let him drink only a few swallows if he is going to stand still. Do not fail to water him at night after he has eaten his hay.
4. When he comes in after work, sponge off the harness marks and sweat, his eyes, his nose and mouth, and the dock. Wash his feet but not his legs.
5. If the thermometer is 75 degrees or higher, wipe him all over with a damp sponge, using vinegar water if possible. Do not wash the horse at night.
6. Saturday night, give a bran mash, lukewarm; and add a tablespoonful of saltpetre.
7. Do not use a horse-hat, unless it is

a canopy-top hat. The ordinary bell-shaped hat does more harm than good.

8. A sponge on top of the head, or even a cloth, is good if kept wet. If dry it is worse than nothing.

9. If the horse is overcome by heat, get him into the shade, remove harness and bridle, wash out his mouth, sponge him all over, shower his legs, and give him two ounces of aromatic spirits of ammonia, or two ounces of sweet spirits of nitrate, in a pint of water; or give him a pint of coffee warm. Cool his head at once, using cold water, or, if necessary, chopped ice, wrapped in a cloth.

10. If the horse is off his feed, try him with two quarts of oats mixed with bran, and a little water; and add a little salt or sugar. Or give him oatmeal gruel or barley water to drink.

11. Watch your horse. If he stops sweating suddenly, or if he breathes short and quick, or if his ears droop, or if he stands with his legs braced sideways, he is in danger of a heat or sun stroke and needs attention at once.

12. If it is so hot that the horse sweats in the stable at night, tie him outside, with bedding under him. Unless he cools off during the night, he cannot well stand the next day's heat.



# TIMELY TALKS WITH OUR SUBSCRIBERS

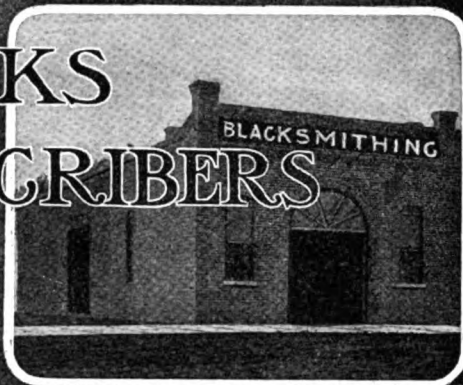

The American Blacksmith is published monthly at The New Sidway Building, Buffalo, N. Y., U. S. A., by The American Blacksmith Company. Incorporated under New York State Laws. Entered, February 12, 1902, as second-class mail matter at Buffalo, N. Y., Act of Congress, March 3, 1879.

William F. Wendt, President

Albert W. Bayard, Secretary

Harry O. Mitchell, Editor

Associates: Bert Hillyer - A. C. Gough - Dr. Jack Seiter

Subscription Price: \$1.00 per year in advance, prepaid to any postoffice in United States or Mexico. To Canada, \$1.25; other countries, 6 shillings. Reduced rates to clubs of five or more on application. See "Honor Roll" page for money-saving, long-time rates. Cable address, "Blacksmith," Buffalo. Lieber's Code used.

Subscribers should notify us promptly of non-receipt of paper or change of address. In the latter case it is necessary that you give us both the old and the new address.

## A NEW CONTRIBUTOR

About once in an age we find a letter in our mail box from an enthusiastic reader telling us just what's what. And in following that letter up, we discover a toiling brother of the craft hidden away by the smoke of his forge and deaf to the world behind the clang of his anvil—and lo and behold!—that grimy son of Vulcan becomes a contributor to our columns. It is just such practical men—iron bruisers, who know their business from A to Z, that we are always glad to shake hands with and welcome to our pages—men like James Cran, Bert Hillyer, Bill Bishop, Maloon and others—you know them all, good friends of the fine old craft. And now comes another—William Ost.

Readers will perhaps recall Mr. Ost's criticism of a stock calculation for pipe hangers which appeared in a recent issue. He came right out and frankly told us where we were wrong, and we were glad of it. Now Mr. Ost promises to contribute regularly. His articles will treat on the calculation of stock for forgings of all shapes, color, species and varieties.

Remember what we said not long ago about "Co-operation?" This is *real* co-operation, and the more of it, the more valuable Our Journal will be to you and every other reader. Let us hear from you, reader. Get busy one of these days when work is slack and contribute something of your own experience for the benefit of brother craftsmen. Don't hold back on account of grammar—just go right ahead like you would hammer out a forging, and if any polishing is needed, we can add that ourselves.

### Subscription Agents

When a stranger solicits your subscription to THE AMERICAN BLACKSMITH or any other publication, insist upon him showing you absolute proof that he is an agent in good standing and is employed by the publication which he represents. Don't under any circumstances, give the man your money if you are not sure that he really works for the paper he says he does. No matter what the man offers you—no matter what price he makes—no matter what premium he promises to send—Don't Give Him Your Money If You Are Not Sure.

## CONTENTS, AUGUST, 1917

Hydro-Construction and the Part the Blacksmith Plays—Frontispiece....	262
Some Cures and Remedies by Shoeing	263
Some Common Sense Remedies by Shoeing .....	265
Ring Bone and Side Bone .....	266
Hydro-Construction and the Part the Blacksmith Plays—Article .....	268
Put the Power Hammer to Work—3	269
How to Calculate Amount of Stock for Forging Weldless Rings .....	271
When is a Man too Old for Useful Work? .....	272
The Smith in the Daily News .....	273
The Kid Has Gone to the Colors—Poem .....	274
Heats, Sparks, Welds .....	274
Our Honor Roll—Kansas Still Undefeated Champion .....	275
The Machine and Tool Smith .....	276
Bending Steel Bars .....	276
The Oxy-Acetylene Plant—6.....	280
To Detect Cracks in Fine Tools ....	281
Benton's Recipe Book .....	282
To Remove Old Oil, Paint or Varnish	282
Queries, Answers, Notes .....	282
An Old Friend Back in the Craft..	282
Wants Suggestions Concerning Side-Lines .....	282
Who Can Supply this Crank Shaft?	282
From a Subscriber in Florida .....	282
Describes a Handy Tire Bender....	282
A Few Queries on Forging .....	282
Some Questions on Plow Work....	283
The Automobile Repairman.....	284
The Care of Tires—5.....	284
Gas Engine Operation Made Simple—11 .....	285
Uncle Sam's Power Hammers on Board a Man-o'-War—Illustration	286

## THE SHOERING NUMBER

This month our feature article is devoted to shoeing. The mechanical treatment of lame horses is a subject of ever-increasing interest to the practical horse-shoer and one on which too much can never be written. In this issue appear several excellent articles which should interest every reader who has the welfare of the horse at heart and is really anxious to do what he can to make life easier for this noble beast.

Nearly every shoer who has given the matter of scientific shoeing any thought whatever realizes its value and has no doubt worked out shoes after his own fashion to remedy such cases as have come his way. Descriptions of some of these cases, similar to those related elsewhere in this issue, if sent in by readers from all parts of the country and abroad, would be of inestimable value to the trade at large.

### NEXT MONTH

Do you know all you wish to know about practical business methods in the shop? Of course you want to know more about such topics as cost-finding, accounting, etc., and you will have an opportunity next month to revel in many excellent articles on these and allied subjects. They will touch on purchasing, pricing the work, smith-shop accounts, collecting, advertising, and the value and choice of profitable side-lines for the blacksmith. You surely have some good, effective ideas of your own along at least one of these lines. Why not send 'em along for the benefit of others?

And Brother Bishop will treat us, in this issue, to a delectable fancy called "The Cruise of an Anvil Pounder." You know B. B's style and in his story of a blacksmith at sea we'll warrant you will find a round dozen laughs that will do your heart good. We're telling you about this unique story now so our friends will not miss a good thing when it comes along—watch for it in the September number.

### SHOP PHOTOGRAPHS

Did you ever have your shop photographed? Summer is the best time to have it done, and if you have the kind of a shop that's worthwhile showing to others, send us a picture of it and we'll get it into "Our Journal" where your brother craftsmen can see it and know what kind of a place you are working in.



*Nestled between the hills are the snug homes of workmen.*

*Everything a blacksmith could ask for is provided in the well-equipped shop.*

*Above a turbulent mountain stream rise chuting-towers said to be the tallest ever built.*

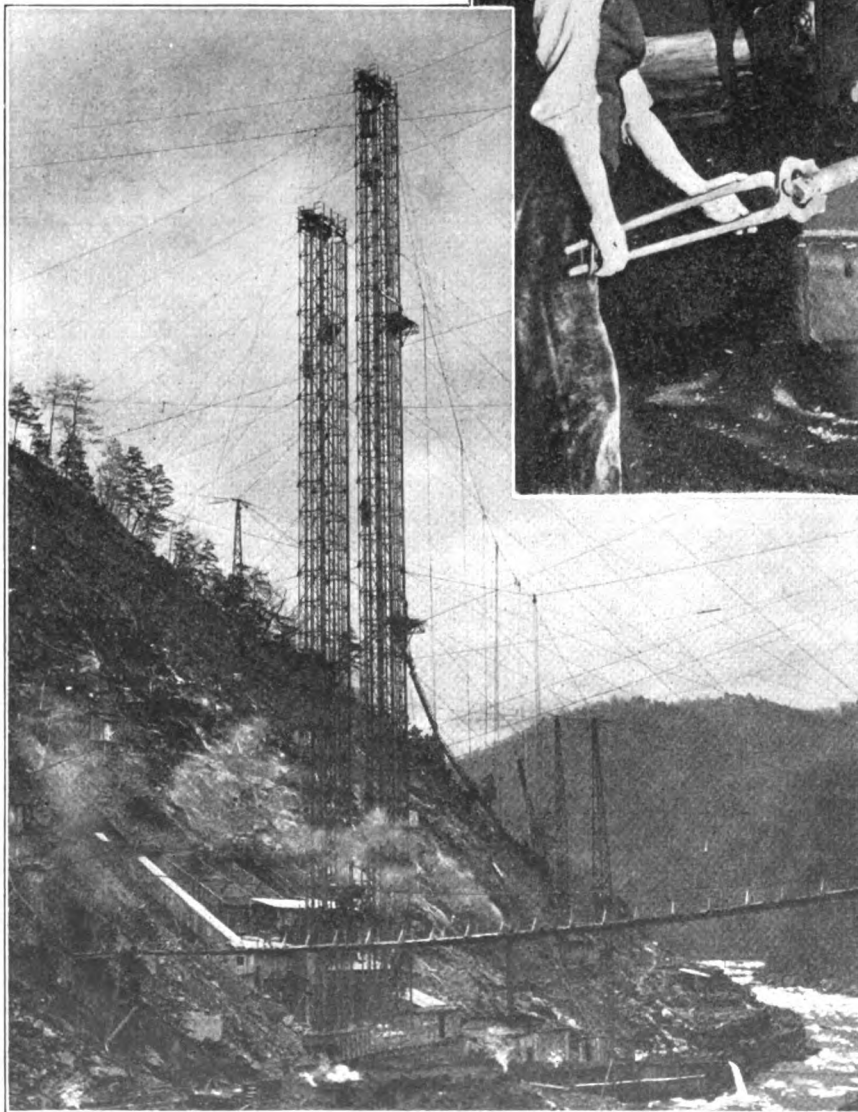
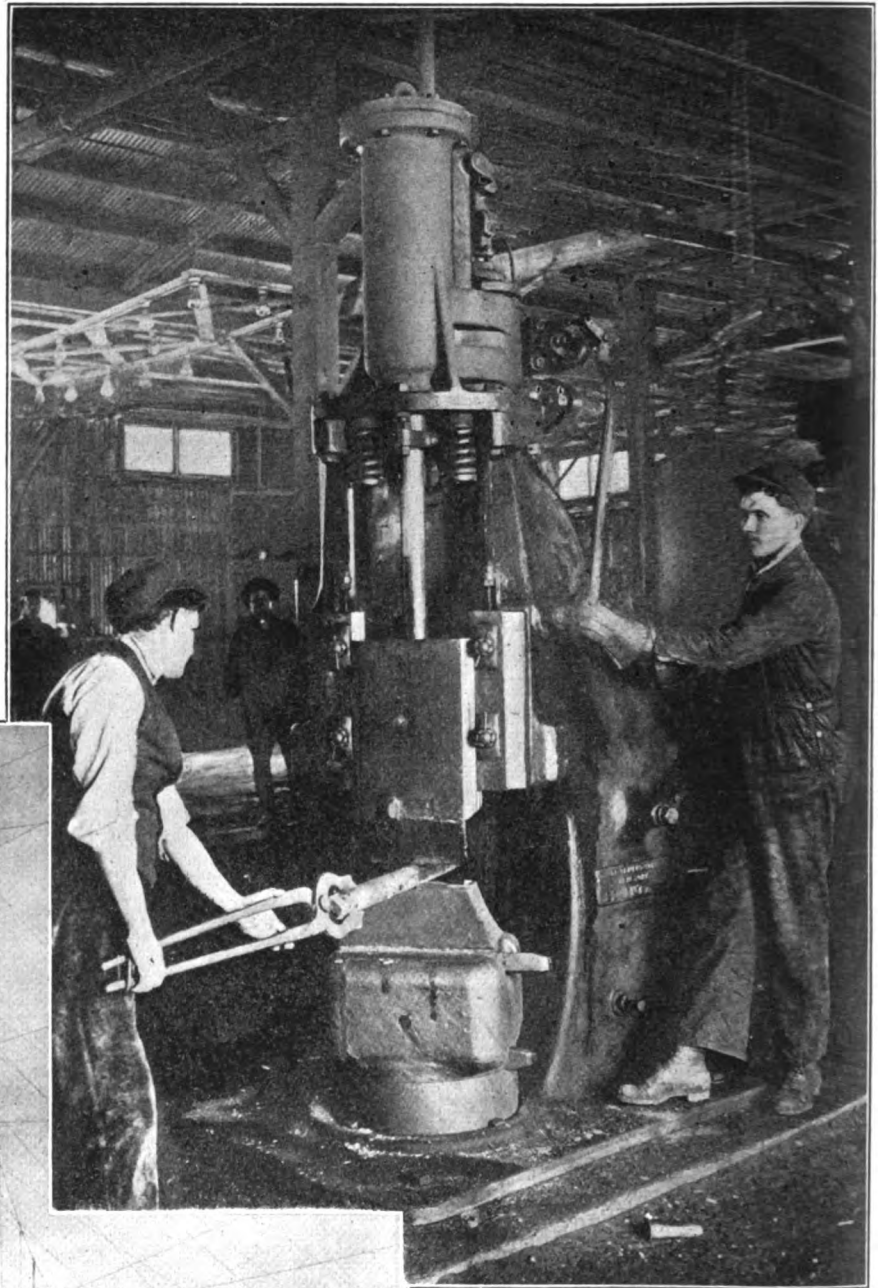

### HYDRO-CONSTRUCTION AND THE PART THE BLACKSMITH PLAYS

*The building of a great government dam is a tremendous undertaking and the part the blacksmith plays is vital indeed; for upon him devolves the task of forging tools, devices, and parts for which there may be little or no precedent. See Mr. Lamon's article describing the big Cheoh Dam in Tennessee.*



# Some Cures and Remedies by Shoeing

BY A. L. CAMP

A patron of one of my standard stallions owned a grade morgan mare from which he raised four foals. This mare was afflicted with side and ring bones. Contrary to my belief in the transmission of this defect through inheritance the foals reached maturity free from blemish. But at last the oldest, which was one of the finest roadsters in the vicinity, went lame and gradually became dead lame. The case was brought to me and diagnosed as side bone. This occurred on the outside of the right fore foot. I found the foot was unlevel by being a good bit higher on the outside. The owner said he had dressed it that way purposely, prior to the lameness, and had increased the condition since by repeatedly lowering the inside.

I at once reduced the hoof to a lateral level and shod with a thick webbed shoe beveled on its outside branch from bearing to ground surface, and from heel to toe, but with inside unchanged. (See Fig. 1.) The effect was magical, changing an apparently hopeless cripple to a faultlessly gaited trotting roadster

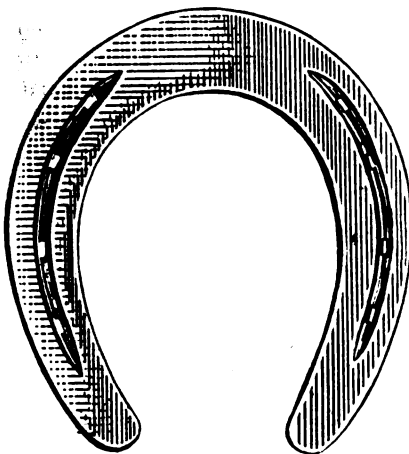

FIG. 1.—A BEVELED SHOE FOR SIDE BONE ON THE RIGHT FORE FOOT

as of old. If the side bone had been on the inside, the treatment would have been the same, but shoe rolled on inside instead of as above.

This bony growth was caused by compression upon the lateral car-

tilage induced by the concavity formed by the raised outside. This treatment relieved the pressure and the accompanying pain, and the animal is still going sound after a year and a half.

I do not want to be understood as claiming to have made a cure of

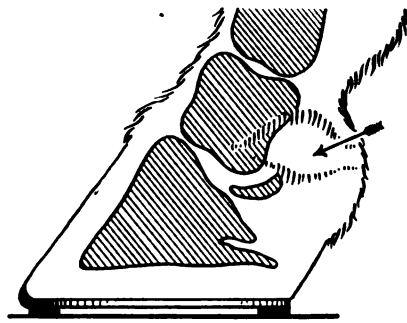

FIG. 2.—X-RAY VIEW OF HOOF ILLUSTRATING CONDITION DESCRIBED BY MR. CAMP BEFORE REDUCING HEELS—ARROW POINTS TO SEAT OF RING BONE

the ossification, for that is there to stay. If the same method of shoeing, as originally followed, were returned to, no doubt the lameness would also return; but the animal is as serviceably sound now as ever.

Another case of double side bones on both fore feet, where the patient was almost beyond the power of locomotion, was a draft horse. In this case the heels were several degrees higher than Nature intended. This threw more of the weight transmitted from the short pastern to the coffin and less to navicular bones than is their just share. This pushed the coffin forward and crowded the ossified cartilages against or into the narrower portion of the hoof. On reducing the heels the horse was relieved from pain in standing or moving and did serviceable and steady work. This will usually be the result of careful treatment, although as in all cases of ossification there remains a constriction of the normal free and natural flexion.

Without doubt the tendency to these diseases of side bone and ring

bone is inherited. That is, the tendency, but not the disease itself. It would seem that some idiosyncrasy of nature caused the progeny of families subject to these afflictions to develop ossifications from wounds or bruises that to ordinary animals amount to little or nothing. I remember one instance especially: a mare with ring bones worked one summer on a road scraper with her mule-foal following at liberty. Being always hungry, the mule, in trying to suck when the dam was turning around, got its feet and pasterns trod on and before it was weaned every foot was adorned with ring bones.

These usually form at the junction of the coffin and short-pastern joint or the next joint above. They may be large, or small and insignificant. The injurious effects are governed mainly by the amount of bone deposit in the joint. In severe cases articulation ceases and the parts intended to flex become as rigid as a continuous bone. Treatment of such must be carried on in consideration of the absence of natural flexibility. It is not a question of a cure but a palliative. Heel or toe calks are entirely out of place here, for the strain and

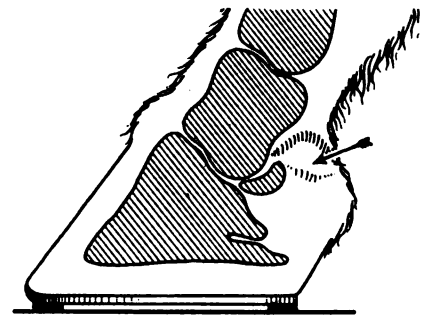

FIG. 3.—X-RAY VIEW OF HOOF AFTER REDUCING HEELS. COMPARE WITH FIG. 2

exertion of "breaking over" is more than the patient can stand up under.

The method must imitate that of the "peg legged" man whose wooden stump is rounded where it meets the ground; that is, the ring bone





foot must roll over. Several types of shoes give such results, of which figures No 4 and No. 5 are most efficacious. The first is a full rolled or rocker shoe which is thickest at the center and thins away at heel and toe. Fig. 5 gives as good results and has the advantage of being lighter and easier to make. This is an ordinary shoe with a bar welded across its center. Many an otherwise useless cripple, treated and shod properly, will do the slow work of the drafter with satisfaction to the teamster and freedom from pain to itself. I hope none of my readers will expect any of the above examples to do work requiring speed, for the loss of the foot's flexibility has made that forever impossible.

With driving horses, and aside from lameness, the problems of shoeing are enhanced by the susceptibility of foot interference;

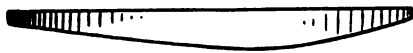

FIG. 4—A ROLLED OR ROCKER SHOE SUGGESTED BY MR. CAMP; THICK AT CENTER AND THINNED AWAY AT HEEL AND TOE

of which ankle-hitting and forging in the roadster, and knee-knocking and speedy-cutting with the race horse, are most common. Of these, knee and ankle-hitting are from un-level feet, while forging and speed-cutting are from improper angle. Of the former, the feet assume a position of divergence from the knee or hocks down, because of the outside being too high. Standing thus, the fore feet, when uplifted, will flex-in towards the opposite leg and the hind feet will do the opposite—flex-out. This seems both strange and unreasonable, but it is nevertheless true. I can only account for this, and a majority of other opposite effects in fore and hind feet, from the fact that the knee breaks forward and the hock backward. So consistently does this "opposite-effect" rule apply that I do not hesitate to recommend its use.

When an uplifted fore foot flexes-in, the animal will hit the opposite ankle at a slow gait, and the knee when at speed. This foot has become crooked from having been un-level and until dressed properly the shoe cannot be set on straight with the leg. The treatment should be

to lower the outside heel and generally the inside toe. Now set the shoe on straight with the leg. This will leave the inside toe projecting beyond the shoe as in Fig. 6. When this projection is rasped away the foot will not flex-in and the animal will not strike the ankle or knee.

Contrary to the fore, the hind feet that strike the ankles, although like the fore feet in being too high outside, will flex-out. This condition brings the ankles closer together and also causes an inward swing to the foot as it leaves the ground. This brings it against the opposite ankle. These feet should be dressed level and the shoe set on straight with the leg which will leave a projection on the outside toe. This should be removed with the rasp as are the inner toes of the front.

When the hind hoof strikes the toe of the fore foot it is termed scalping. When that portion of the pastern above the hind hoof strikes the toe of the fore foot it is speedy-cutting. Both are from the same cause, but in speedy-cutting the fore foot is more flexed and usually at a faster gait. Both are the effects of failure in unison or simultaneous action of the fore and hind limbs. That is, the "pickup" of the fore foot is delayed, or that of the hind foot is accelerated.

Usually both conditions are present. This is because the angles do not correspond. The rule of opposite effect mentioned above applies here. An acute angle in front makes

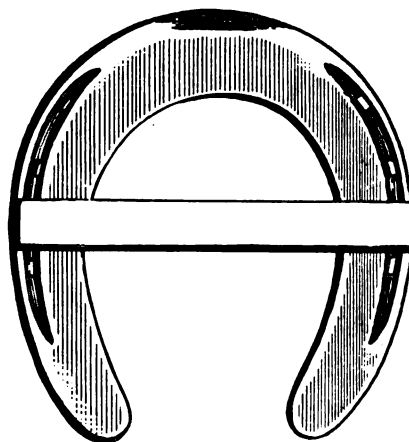

FIG. 5—MR. CAMP'S BAR SHOE FOR RINGBONE

an earlier "pickup". An acute angle behind, a slower one. This, then, is the answer for a remedy for scalping and speed cutting. I fully

understand that the formula for quickening the action of the fore feet is to raise the heel and roll the toe. This does make an easier "break over" but delays the pickup; for the body of the animal will advance more forward before the foot leaves the ground than if the opposite obtains. I think I am safe in asserting that ninety-nine per cent are shod to

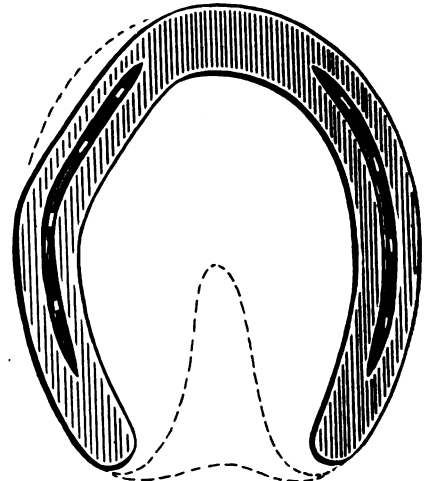
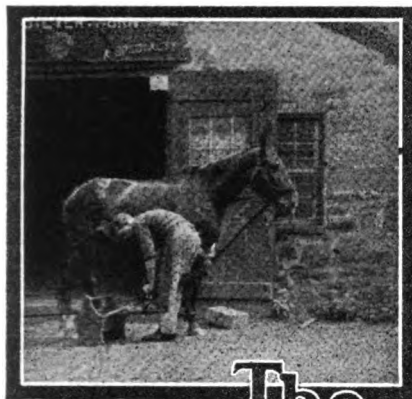

FIG. 6—SHOE FOR KNEE-KNOCKING AND SPEEDY-CUTTING. THE PROJECTING PORTION OF HOOF AT TOE SHOULD BE RASPED AWAY. THIS SHOE IS FOR THE RIGHT FOOT

correct the above named gait-defect by leaving higher heels all around. This is contrary to the right way, for it slows in front and quickens behind, when the reverse is desired.

I am not a horse shoer by trade. My earlier years were devoted to farming and stockraising. For about thirty years I have engaged almost exclusively in breeding, training and racing the harness horse. So unsatisfactory were results obtained at the shoeing shop that I learned the art to obtain better results. Every year I have a string of trotters and pacers on some western circuit. As evidence of the efficacy of my methods of balancing the race horse I will say that I have not used a knee, ankle, speedy-cut or scalper boot in many years. Nor have I used hobbles and seldom a check rein. I do not believe I have had a horse to make a break in five years. For love of the horse I shoe many horses for gait defects and lameness free of charge. Therefore, as I am not a competitor of the man who lives by the trade of farriery professionally and I hope that jealousy will have no weight with shoers in consideration of whatever views I may set forth.



## The Horseshoer.

### Some Common Sense Remedies by Shoeing

E. H. MALOON

Recently I received a letter from Mr. O. Keif of Woodland California, which I think would be well to answer through the American Blacksmith as the subjects mentioned are ones every horseshoer would be interested in. He asks about interfering and quarter-crack, and I will describe the remedies I use myself.

As you already know, I advocate natural shoeing, hence I have no freak shoes to offer. If a horse's leg or foot is normal, I shoe on what I call *general principles*; that is, lower the foot from the bottom so it will bear on the floor alike all round, thus making all sides of the foot carry equal proportions of the load. I now take my dividers and set them at the point of the frog and describe a half circle, thus making the sides and toe of equal length, and take off the hoof to the line I have made. Then I set my dividers on the cleft of the frog at the widest part of the hoof and make both sides alike, and follow this up by fitting on a light steel shoe close on the inside and with no calk at the heel. Whatever thickness I need I get by simply thickening the shoe. This kind of shoeing usually does the business.

Sometimes I put on a flat shoe, drawing the heel down back of the nails on the inside like a wedge and leaving it to an edge at the end. It is a good rule to fit close—never leave anything on the inside that will wound the opposite leg. This is one rule that is always safe to follow on a horse that interferes. I have had many horses that wounded

the opposite leg with the ground surface of the calk; that is why I always discard inside calks when shoeing for interfering.

I have no certain way of shoeing for interfering forward, nor have I ever hired a man who did have. One thing is certain, take the shoes off a horse that hits either forward or behind, and he will soon wear his feet down to the point where he can go with the least resistance and that point is the best any shoer can ever hope to approach, as it is just where his muscles say it shall go. At that point you can put on a low-calked shoe with the toe calk placed just where he wants to break over. Or you can put on a light, flat shoe, close-fitted. You can then feel that you have done all that anyone could possibly do to make him go clear.

While I do not think I can change the gait of the horse that travels six or eight miles an hour, I do know that I can help him very much by making common sense changes in his shoes. I object to a horse stumbling over his toe, so I remove the calk and turn up the shoe and he goes clear. I object to a horse falling from weak ankles or knees, so I put on a high toe and he goes safer.

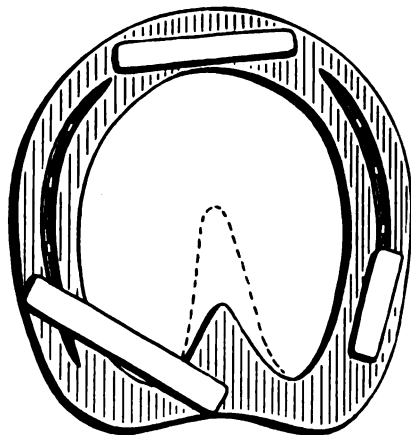

**A SENSIBLE SHOE DESIGNED BY MR. MALOON FOR REMEDYING CORNS OR QUARTER-CRACK. THE LONG CALK AT THE LEFT TAKES UP ALL SHOCKS AND DELIVERS THEM WHERE THE FOOT IS SOUND**

If a horse stumbles and you have to calk him, put the calks where he breaks over his toe; for a horse that toes in and breaks over the outside corner of his calk will surely stumble.

My remedy for quarter-crack is one every good shoer follows. That is, cut the hoof back of the crack down about one-fourth of an inch

lower than the ball of the foot and put on a bar shoe with a calk like that shown in the accompanying illustration.

I use leather packing with tar to take out soreness, and burn across the crack at the hair with a very thin three-quarter inch chisel. This chisel has a shoulder on it five-eighths of an inch from the edge in order to keep it from going in too far. Now with knife and file, I make the edge of the crack thin and put in a worm if possible. This is done as follows: take a small gimlet-bit and bore across the crack as high up as thick hoof is found. Then thin a nail and drive it through the hoof and clinch. I will warrant a cure if this treatment is followed and the owner keeps the foot soft.

I treat corns as follows: cut out at the heel in much the same manner as for quarter-crack and put on the same kind of shoe. I cut the corn out a little and plug in oakum and melt a bit of resin on top. The red part of the corn goes to the coronary band and is incurable. I never use acid and cut off only enough to keep the shoe off the sore part.

After all is said and done, the very best advice I could offer is this: work your brain and don't use freak shoes. Make it as easy as possible for the horse to do his work and he will repay you by not going lame from your shoeing.

Always remember that a horse's foot is balanced and level when the hoof comes into contact with the ground with both sides alike. And that when one side of his foot is not forced to do all of the work, his muscles and feet will last much longer.

Then there is one thing more which would be well to mention in connection with this subject; that is, *the condition of the horse*. If the owner will not keep him in normal condition, but insists on under-feeding and over-working him, he ought not expect you to put muscles into his legs by shoeing and should not blame you for faults due to his own neglect. Much of the trouble laid to shoeing is wholly or partly due to the horse not having sufficient force to put his feet and legs where they would naturally go were he in condition, and did only such work as he could live and be normal under. Personally, I am always willing to father faults in my work, but I will not bear the faults and sins of another and I talk to my customers just as I write to you.



## Ring Bone and Side Bone

*"Will some brother tell me the difference between ring bone and side bone, and the best way to shoe for same?"*

This request was contained in a letter which the editor recently found on his desk, and as it deals with a subject which has been little discussed heretofore, but which is of considerable importance to the horse-shoer, we believe a brief examination into its nature, causes, diagnosis, and methods of treatment by shoeing and otherwise would be pertinent.

*Ring bone*, as the name suggests is a ring-like, bony growth which encircles one or both of the pastern



FIG. 1—RING BONE  
(After Dadd)

bones (Fig. 1), or forms like an arch upon the back of the coronet through which the back tendons obtain passage.

It is in reality a bony tumor—not actually a disease in itself, but rather the result of a diseased condition, usually caused by some injury which was not properly treated and which sets up an inflammatory action in the bony tissues of the large or small pastern bones. In appearance it is somewhat like a spavin, occurring in both fore and hind legs, but more frequently in the hind legs.

It may take different forms, depending upon its location; and the form and position is an important consideration in diagnosing a case of ring bone. When it develops upon the front of the foot, it assumes the shape of a slightly convex swelling; if situated on the lower part, it forms in a thick ring, encircling that portion of the foot immediately above the hoof. Its presence on the posterior part is indicated by a small, bony growth somewhat projecting, sometimes on the inside and

sometimes on the outside of the coronet.

Authorities agree as to the principal causes. Injuries, due to overwork when young and undeveloped, fast work on hard roads, blows, sprains, jumping, etc., are recognized as the most common causes of this malady, although it may originate in heredity, a fact of no little importance in its relation to questions connected with breeding. An indirect cause of this trouble, as well as many others, is improper shoeing, such as the employment of high calks, and a too great shortening of the toe and correspondingly high heels.

The symptoms of ring bone do not reveal themselves plainly until a somewhat advanced stage of the disease is reached. It is then indicated by a characteristic lameness peculiar to this trouble. It takes slightly different forms, depending on the position of the growth. In case the affected part occurs in a fore leg, the heel will first be placed upon the ground, and the ankle held as rigid as possible. In the rear leg, however, the foot strikes the ground, toe-first as in health, but the ankle is kept rigid as in the fore leg. This is the case when the ring bone is high on the ankle; but if it is located under the front tendon, or involves the coffin joint, the heel will be brought to the ground first.

This lameness appears in a more or less acute form, depending on the



FIG. 2—THE FOOT SHOULD BE BALANCED TO PREVENT AN ABNORMAL STRAIN ON THE LIGAMENTS

seriousness of the case, and its advancement. Inflammation usually accompanies its development for some time and a swelling over the affected parts, but this subsides in

time as the growth becomes hardened.

In some cases ring bone results in an incurable lameness. Usually, however, the patient recovers after the formation of the bony tissue is

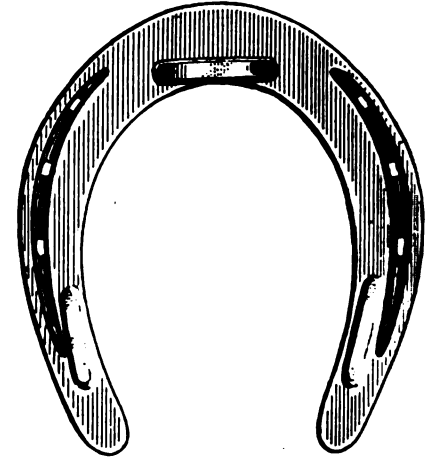

FIG. 3—SHOE FOR RING BONE IN HIND PASTER

complete; a stiff joint only remaining. Even in the most serious cases, where full recovery may not be expected, careful attention on the part of the horseshoer will help to remedy the condition and make the animal serviceable. Unless he is an expert in the treatment of diseases of the hoof, it is not advisable for him to attempt any treatment further than to alleviate the inflammation by the use of cold baths, followed by blistering with biniodide of mercury and cantharides, allowing the animal to rest for a period of a month or more, and then shoeing carefully. Any other form of treatment should be left to a competent veterinarian.

The form of shoeing should be directed toward properly balancing the foot, thus preventing an abnormal strain upon the ligaments. This may be determined by simply shaping the shoe so that the axis of the foot, as viewed from the side, will be straightened. That is, so the wall of the hoof from the toe to the coronet will form a straight line with the front of the pastern as shown in Fig. 2.

When ring bone occurs in front, the horse should be shod as for side bone, which will be described elsewhere. (See Fig. 8 for type of shoe recommended). For ring bone on the hind pastern, a shoe should be employed which lowers the toe and raises the heel, as in such a case the foot is lengthened at the toe and is consequentially higher at the heel. (See Fig. 3). The idea is to ease off



the strain on the tendon at the rear of the foot which is contracted by the disease. Therefore, a shoe should be used with very low calks

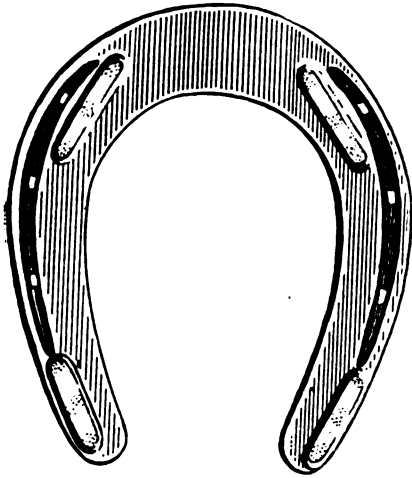

FIG. 4—A FOUR-CALK SHOE FOR RING BONE. RECOMMENDED BY PROF. RICH

all round, but slightly higher at the heel than at the toe.

One authority recommends a shoe with calks one-half an inch in height at the toe and one inch high at the heels, the latter to be set about one inch from the points of the heel. However, we believe, calks not quite so high should be used in order to gain the best results.

Another suggests the employment of four calks instead of the usual three, wisely pointing out that in such cases the animal will find it less painful to travel when his shoes have an equal foundation. (See Fig. 4).

He further states that with such a shoe he has known horses, who could scarcely hobble on a three-calk shoe, get along with hardly a limp when properly shod with four calks. It is a good idea to avoid the toe calk altogether, if practicable; for the closer to the ground the foot, the easier for the horse, and the more certain will be the effect of such remedies as are employed.

Bar shoes are sometimes used to good advantage, a "roller-motion" toe being employed, and the hoof being thinned near the coronet.

Side bone is a hardening of the cartilages found on the wings of the coffin bone, just above the coronet near the heels. (See Fig. 5). These cartilages are normally soft and to a degree flexible, permitting the soft structures of the foot to expand and conversely contract in action; but when affected with this disease are transformed into a hard, unyielding bony substance.

Side bones are situated on one or both sides of the leg at the coronary band, bulging above it in the form of two hard bodies, irregular in shape and unyielding to the pressure of the fingers. (See Fig. 6).

Side bone is caused by violent concussion or shock due to fast work upon hard roads, in much the same manner as ring bone.

It is also brought about through predisposition in heavy, lymphatic horses—usually heavy draft animals. Or it may originate in certain diseases affecting the foot proper such as corns, quarter cracks, or quittor. Usually a shock, sprain or bruise is the underlying cause, and this followed by inflammation brings about a peculiar ossification of the cartilages—an earthy or bony substance being deposited until they take on almost the same formation as the coffin bone itself.

One authority states that high heels and contraction is the main cause of side bone. In such case the contraction of the walls would cause a pressure against the sides of the coffin bone, resulting in an inflammation and consequent formation of the bony deposits in the cartilages of the foot. This, however, would seem rather to be a secondary cause, the high heels and contraction resulting from other causes as before mentioned.

The symptoms of side bone are easily discernible, although it is difficult to determine from them the exact state of advancement of the trouble. A peculiar feature of its progress is that the horse may be more severely crippled during its early stages than in a later. This is due to the severe inflammation and swelling which often sets in when the formation is nothing more than a small bony tumor.

Lameness is always a sure sign, if accompanied by a hard bulging



FIG. 5—SIDE BONE (After Stonehenge)

around the coronary band. It is best detected after the animal is cooled off after labor or exercise. Another marked symptom accompanying a swelling and heat around

the coronary band, is a short and cautious gait on the part of the horse.

Where the formation has taken place on only one side of the foot—usually the outer wall, one will observe that this side of the hoof shows considerably more wear than the opposite inner side. This is due to an unequal expansion and contraction on opposite sides of the foot—the afflicted side remaining stiff and unyielding, while the inner side gives to the pressure of the weight. In time this will cause a wry hoof, and the logical remedy for such a



FIG. 6—THE ARROW INDICATES THE LOCATION OF SIDE BONE IN A TYPICAL CASE

condition will suggest itself to the scientific shoer. (See Fig. 7).

Side bone may be treated medically and mechanically; the particular form of remedy applied depending on the stage and condition of the disease. In its early stages the thing to do is to relieve inflammation and allay, as far as possible, the growth of the bony formation. The same treatment as suggested for ring bone is advisable in cases of side bone. That is, employ the cold bath and frequent soaking of the feet in cool water, and at a later period either paint the surface of the foot at the point of the swelling several times daily with tincture of iodine, or rub in an ointment made by mixing 1 dram of iodine crystals with two ounces of vaseline.

A more effective remedy, in case this fails to remove the inflammation, is the application of a Spanish-fly blister, to which a few grains of biniodide of mercury have been added. If this treatment is ineffectual, the case should be



turned over without delay to the attention of a veterinarian.

Several kinds of shoes are recommended for the mechanical treatment of side bone, after the inflammation has been relieved. In any case, it is best to employ a flat shoe and to carefully trim the sole. Usually, in cases where side bone is well developed, the sole will

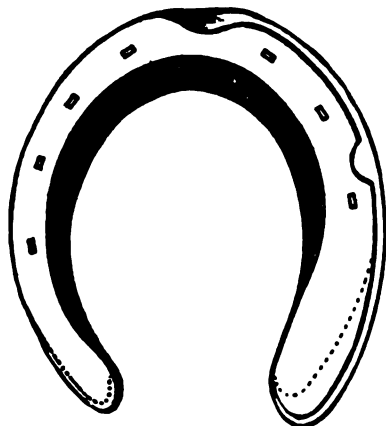

FIG. 7—SHOE RECOMMENDED FOR WRY HOOF CAUSED BY SIDE BONE

be found to be quite thick—sometimes as much as a half an inch. This deprives the coffin bone of its normal expansion under the pressure of the horse's weight, in addition to its being contracted by the rigid walls of the bony cartilages. One must, therefore, thin this sole before shoeing. Carefully pare it down to about thumb pressure, equally all around and lower the wall just enough so there can be no possible sole pressure. Then weaken the bars of the foot a trifle to allow the use of a hoof expander.

A good shoe for side bone shoe is pictured at Fig. 8. This is recommended by Mr. Thomas F. Hayes, a well-known specialist in the mechanical treatment of lame horses. It is scooped at the toe to prevent any part of the toe from touching the ground, rolled short and thin at the heels.

The shoe previously mentioned and pictured in Fig. 7 is made with a broad outer branch—considerably more so than the inner. In applying, the inner branch follows the edge of the wall of the hoof closely, while the outer branch extends beyond the wall far enough to touch with a perpendicular line dropped from the coronet to its edge. This shoe is flat and punched deep on the outer branch and fine on the inner. As the outer half of the hoof will soon grow too high, it is well to place a side-clip on the outer branch.

Where the ossification has affected only one side of the foot, bar shoes and rubber pads may be used to advantage. But their use, in case both cartilages are hardened, is not recommended as results are apt to prove injurious.

It might be well to mention at this point that the expression of others' opinions and descriptions of their own methods of treating cases of ring bone and side bone would be valuable, and the editor will gladly welcome such contributions to "Our Journal".

### Hydro Construction and the Part the Blacksmith Plays

J. C. LAMON

There is hardly a person but feels a keen joy in the making or building of something—each one of us has experienced that feeling. But add to this the usefulness and need of the object we are to build, and the joy becomes doubled. And so it is when we hear of the construction of some marvelous piece of workmanship by others—we can share much of their enthusiasm and interest in the work ourselves, even though we may actually take no active part in it.

Deep in the recesses of the Great Smoky Mountains of Eastern Tennessee, a hive of busy workmen are

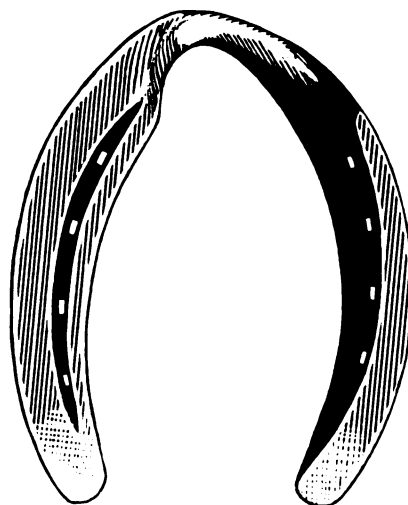
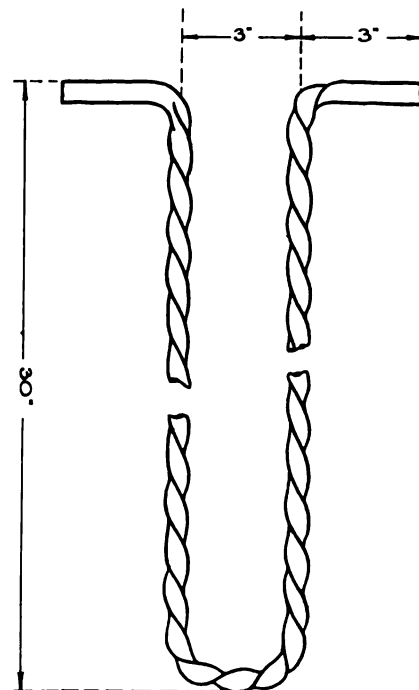

FIG. 8—A SHOE DESIGNED BY MR. HAYES FOR SIDE BONE; ALSO FOR RING BONE IN FRONT

engaged in one of the greatest hydroelectric development projects ever attempted in the United States; a mighty work that taxes the ingenuity and skill of master craftsmen of many different trades. The part the blacksmith plays is interesting in-

deed, for his work is a most vital part of the whole.

From one mountain top to another—spanning a gap of two thousand, seven hundred feet, will



1—TWISTED BAR RE-INFORCEMENTS

rise one of the eleven huge dams which will eventually complete the project, the Cheoh Dam. A brief description of this one dam alone will give the reader a faint idea of the tremendous undertaking. It will rise to a height of one hundred and sixty-six feet from the creek bed shown in the frontispiece—the estimated cost of construction reaching into the millions, and will require six years to build. This unit will develop some eighty thousand horse power. The discharge of the giant pumps operating in the coffer dams can be seen emptying into the creek at the rate of one thousand gallons a minute. The towers rising to a height of three hundred and sixty-six feet, are said to be the highest chuting towers in the world. These are used to distribute concrete from the mixing plant to the dam.

Engraving No. 2 shows the crusher plant under course of construction. This will have a capacity of six thousand cubic yards of crushed stone a day.

The workmen's quarters, which are also pictured in the frontispiece, are pleasant, comfortable houses, and give an observer the impression that here has sprung up a prosperous mining community. The shops, of course, are in close proximity to the



actual operations, and comprise the big crusher plant, mixing plant, pumping station, air compressors, machine and wood-working shops, and the commodious smith shop. The entire plant is operated by electric power developed several hundred miles away and carried to the site of the dam over high-tension transmission cables.

Each day offers something new for the blacksmith to invent, some new problem to solve, some ingenious way to accomplish things for which there is no precedent. Special tools must be designed and worked out on the spur of the moment when a breakdown occurs, as the work is of such a nature that delays would be very costly. One may easily imagine that the blacksmith working on this project never has time hang heavy on his hands. There is always variety in his work, and he finds inspiration for his day's labors among the towering mountains which rise on all sides, the fragrant odors of the forest pines, the bracing air and the bigness of the outdoors.

No blacksmith could ask for finer equipment than that which is installed in the shops at the Cheoh Dam. Pictured elsewhere is the big power hammer in operation, forging out a three-inch eye-bolt. This is only one of the many jobs handled one right after the other throughout the day. Engravings No. 1 and 3 represent two other parts used in large quantities. The anchor rods presenting something of a problem, as several thousand were needed, we rigged up a bending tool which was made to do the work accurately and speedily, greatly facilitating our smithing operations. The rods are bent at one heat, and are used to anchor the concrete forms when completed.

In rigging the towers and many derricks a large number of bolts were required, and we figured out a scale for determining the amount of

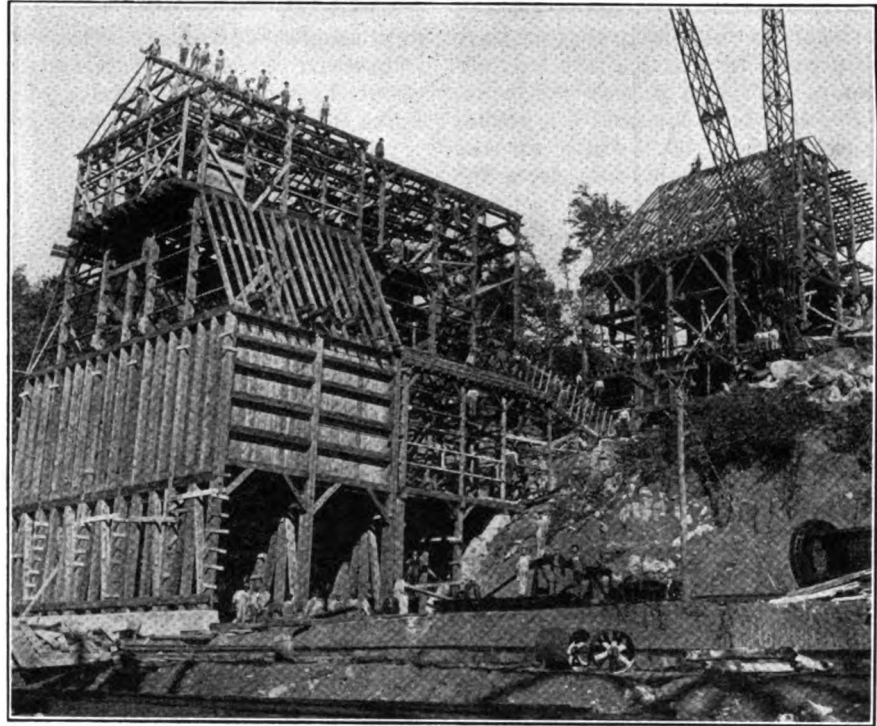

2—THE BIG CRUSHER PLANT IN COURSE OF CONSTRUCTION. CAPACITY OF 6,000 CUBIC YARDS OF CRUSHED STONE A DAY

sions shown will find the length of stock needed for the various sized bolt heads approximately correct.

I could describe many other interesting ways and means which we were forced to rig up as occasion demanded, but think the foregoing will suffice to give the reader a general idea of our problems and how absolutely indispensable the blacksmith is in carrying on a big engineering enterprise of this character.

### Put the Power Hammer to Work—3

WILL BISHOP

Eternal hammering is the price we pay for work well done, and work well done is the price we pay for success. And, as we are essentially a hammering craft, it natur-

Journal. Yet, in spite of all my hammering, success seems to be fleet-er of foot and longer winded than I am. At least I've never been able to hammer fast enough to get even a glance of her to see what she is like. But I'm still hammering!

All of which leads to the fact that I'm going to slip you some more hammer tools in this article. After this article, however, we'll take a rest on the tool question and see what we can dig up in the line of hammer forging. This will give us a chance to put the tools we have learned about into practical use. I have, by no means, treated all the tools with which I am familiar; but have merely given a number of the most practical ones to serve as an example of the utility of the hammer when supplied with the proper tools for forging. I am sure that

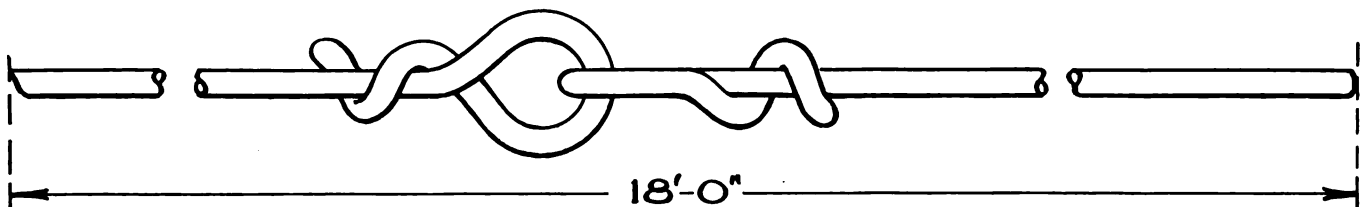

3—THE WAY SEVERAL THOUSAND ANCHOR RODS WERE MADE UP

stock needed for any size bolt. The accompanying engraving No. 5 fully explains itself, and any blacksmith, who has bolts to make, by referring to this table and by using the dimen-

ally follows that we are interested in hammers. After hammering all day, I come home and hammer out these spasms on the hammer and hammer-tools for the readers of Our

to a blacksmith this pointer is all that is needed to enable him to make all the tools his needs require.

The tools treated in the following are of the stamp, or die, class. At



Fig. 1. you will recognize the old familiar lap-link stamp that we have all used on the anvil. For a hammer stamp, a block of soft steel 3 inches wide, 4 inches long, and  $1\frac{1}{2}$  inches thick is required. Heat up the block and stamp lap-link from the size required; after which drill a  $\frac{3}{4}$  inch hole about  $1\frac{1}{2}$  inches deep in one end of block. Make a handle as per sketch, heat end and drive into the hole until tight and calk in with a center-punch as at A. Puffectly simple, huh? And on some dull day in winter enough lap-links can be shelled out to last all summer.

We are often called upon to make brackets or other forging requiring a round shank and a flat cross-end. Usually, we weld the round onto the flat, which, at best, is not any better than it should be in the way of finish and durability. Take a squint at the sketch of a bracket-end stamp at Fig. 2. This stamp makes 'em while you wait, and, take it from me, there is nothing lacking in finish and strength when a bracket comes out of this tool. Of course, the size of this tool all depends on the size of bracket wanted. For illustration, we will take a bracket with a  $\frac{3}{4}$  inch shank and a  $1\frac{1}{4}$  inch by 3 inch flat cross-end; the flat to be  $\frac{3}{8}$  of an inch thick. See section B for complete sketch of model, with dimensions marked. Forge out the bracket and finish nicely with a file. Heat the block fairly soft and lay on bottom die of hammer, place bracket model on the block and drive down into block flush with top. If the

pression together a trifle, taking up any excess expansion. When the impression is brought up to just about the size of the model used to make it, place the model back and

her up, and you have a bracket that looks like it had been molded.

Many times a smith is pestered with a job that calls for a small plate with a lug on one side; and if he has

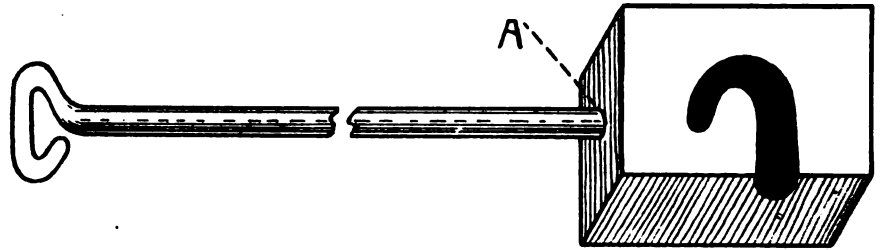

FIG. 1.—A HAMMER-STAMP FOR MAKING LAP-LINKS

drive down flush again. This treatment usually makes a perfect impression. Drill hole for handle and put in the same as directed for lap-link stamp. This finishes the tool and it is ready to stamp out any number of bracket-ends that are wanted.

Now for making the brackets in the tool. For this we need a piece of  $1\frac{1}{4}$  inch round iron. Draw out and swage the shank down to  $\frac{3}{4}$  inch, leaving the shoulder where the shank starts as near square as possible. Cut off above shoulder, leaving  $1\frac{1}{4}$  inches of the original stock. This gives a  $\frac{3}{4}$  inch shank with a  $1\frac{1}{4} \times 1\frac{1}{4}$  inch head. See sketch at A. Heat the head white hot and place on the stamp so the head comes in center of flat space in the stamp, and the  $\frac{3}{4}$  shank is squarely over the  $\frac{3}{4}$  groove in the stamp. Use a piece of  $\frac{3}{4}$  inch round iron as a fuller to draw out each wing of the

to make it by hand it is a tedious and unprofitable job, nine times out of ten. But, if he has a hammer and a tool like the sketch at Fig. 3, when that lugplate job comes in he grabs a piece of iron and shoves it into the fire; and while it is heating, he whistles a bit of rag-time just to show the customer that Lug-Plate is his middle name. When his iron is hot he draws out one end until it fits the slot in the tool, (see slot at A.) then cuts off enough stock above the part drawn out to fill out the flat impression around the slot. See sketch at B and C for illustration of shape of iron before it goes into tool. Now the smith heats the piece white heat, sets it in the tool, places tool under hammer, uses a piece of  $\frac{3}{4}$  inch round to fuller out sides and when fullered enough, hammers her down flat. All he has to do now is to punch the work out of the tool, trim her up and drill whatever holes he needs. Sort o' simple, what? Remember that the slot at A goes clear through the tool. See sketch at D for finished lugplate with dimensions marked. This tool is to be made any size that is required; I have used the size shown merely as an illustration.

For ordinary, everyday use, most of us make our eye-bolts by bending and welding the eyes; but it is often the case that we want an eye-bolt with the bolt shank considerably larger than the stock wanted in the eye. For instance, we want a 1 inch bolt with the eye made of  $\frac{5}{8}$  inch stock. Well, to make a long story short, cast your mechanical eye over the tool sketched at Fig. 4. That's the baby that will do the trick and save all that squinting and head-scratching. I'll explain how to make the tool, then how to use it. The model to be used in making the impression in the blocks of this tool should be forged out neatly and

	Dia. Stock	A	B	L
Note: All dimensions in inches.	$\frac{1}{2}$	$\frac{3}{8}$	$\frac{3}{4}$	$1\frac{1}{16}$
	$\frac{3}{4}$	$\frac{9}{16}$	$1\frac{1}{8}$	$1\frac{3}{8}$
	1	$1\frac{1}{16}$	$1\frac{1}{2}$	$2\frac{3}{16}$
	$1\frac{1}{4}$	$1\frac{1}{8}$	$1\frac{3}{8}$	$2\frac{1}{16}$
	$1\frac{1}{2}$	$1\frac{1}{8}$	$2\frac{1}{4}$	$3\frac{1}{16}$
	$1\frac{3}{4}$	$1\frac{1}{8}$	$2\frac{3}{8}$	$3\frac{3}{4}$
	2	$1\frac{1}{2}$	3	$4\frac{1}{16}$

4—A HANDY CHART USED FOR ESTIMATING THE SIZE STOCK REQUIRED FOR VARIOUS BOLT HEADS

impression is not perfect and sharply outlined, place the block edgewise under the hammer and upset lightly all around. This staves the im-

pression is not perfect and sharply outlined, place the block edgewise under the hammer and upset lightly all around. This staves the im-



finished with a file. This insures a neat, clear impression when it is driven into the hot iron. We'll take a bolt with 1 inch round shank, and the stock that goes into the eye of

to 1 inch round as much of stock as is needed for the bolt length. Cut off, leaving two inches of the original stock on the end of bolt. This gives us a 2 inch square head by  $\frac{3}{4}$  inch

thick. Trim the corners and punch a  $\frac{3}{4}$  inch hole in the center of head. See sketch at C for example. Heat white hot, place on bottom section of stamp, under the hammer, so that it covers the impression and lay top section of tool over it, slipping the holes in top section over the studs in bottom section, and land on it until the blocks come together. When it is taken out of the tool the bolt-eye will have a feather edge all 'round, both inside the eye and out. Trim this off with a sharp chisel and have a smile come on your face like a crack in a pie when you look at the be-e-aautiful drop-forged eye-bolt. It will look something like the sketch at section D.

As I mentioned above, this will wind up the tool stuff. I could send sketches and write up dozens of others, but they are all more or less on one or the other of the classes which I have already treated, and I don't consider it necessary to go into any further details. My experience with the iron-stretching fra-

### How to Calculate the Amount of Stock Needed for Forging Weldless Rings

WILLIAM H. OST

Editor's note: In these days of high prices, with iron nearly worth its weight in gold, it is a practical necessity for the blacksmith to conserve every ounce of metal possible. In cutting stock for forgings this is particularly true and great care should be used to cut off just enough for each job and no more than is needed. How to do this and at the same time avoid the risk of not cutting off enough and thus having to scrap the whole piece, frequently presents a problem of no little importance. Too often a smith causes himself much extra hard labor and anxiety because of a mere guess.

The needed length, however, can be closely predetermined by calculation, and it is to point out ways and means of easily calculating or measuring stock preparatory to cutting that this article and those to follow have been prepared by Mr. Ost.

Training in higher mathematics is not common among blacksmiths, and we feel

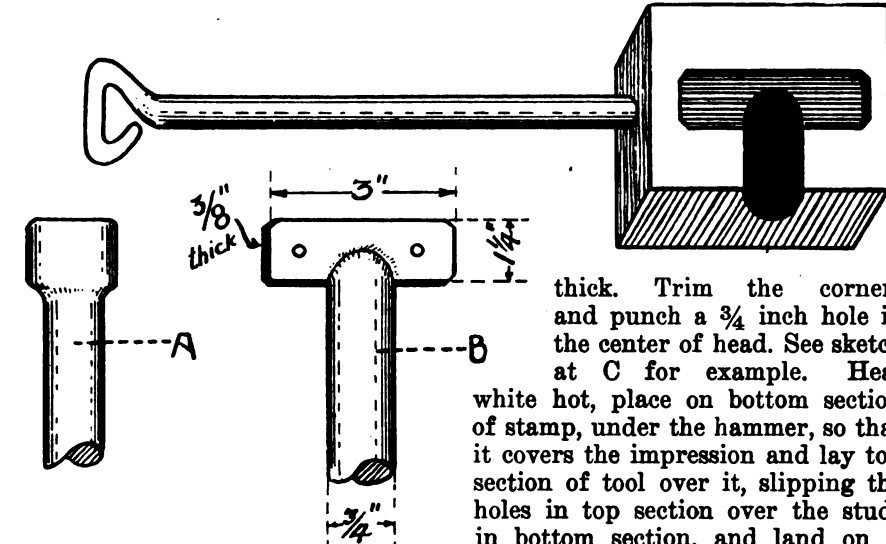

FIG. 2—STAMP FOR MAKING BRACKET ENDS

$\frac{5}{8}$  inch round, and we'll say an eye of  $1\frac{1}{4}$  inch diameter. We need two blocks of soft steel about  $3\frac{1}{2}$  inches square, and  $1\frac{1}{2}$  inches thick. These blocks are to be of the same size. Heat them both to a nice red heat, lay one on the bottom die of the hammer and place the eye-bolt model in the center. Then lay the other block on top so that the block edges are even all 'round and swat her like a thousand bricks. Now take out the model and place between the blocks a piece of smooth, flat, plate-stock  $\frac{3}{8}$  of an inch or so thick and swat her again. After this, take out the plate and replace the model; and this time, don't swat her quite so hard, just tap down until the blocks come together. This should give a perfect impression of the model between the blocks. Next drill  $\frac{5}{8}$  inch holes through the corners as in sketch of top section at B. Place the blocks together, with model in place in the form, and mark carefully with a scratch-awl through the holes in top section the places for the studs at A in bottom section. Drill into bottom section, at the places marked, two  $\frac{5}{8}$  inch holes about one inch deep, adjust  $\frac{5}{8}$  inch pins in these holes and callk them in with a center-punch. When the handles are in as per sketch, the eye-bolt stamp is complete and ready for use.

Now for the bolt-making operation. We'll use a piece of  $\frac{3}{4}$  x 2 inch stock. First draw down and swage

ternity has been that if you give one of them an idea, he will scratch around and dig up a whole raft of ideas to match, and some of them are bound to be better ideas. So go to it, boys, when you need a tool, and make it. Blacksmiths, as a rule, are not stingy with their ideas, new shop kinks or anything else they pos-

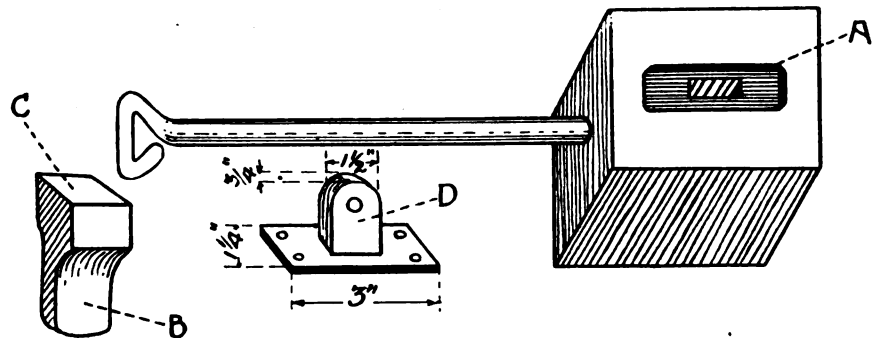

FIG. 3—TOOL FOR STAMPING PLATE WITH LUG

that in presenting this series of simplified calculations to our readers, they will be greatly assisted and benefited. These problems will, for the main part, consist of simple calculations, but the principles involved may be applied, with some modification, to various other forgings and more difficult problems which are bound to arise in any shop.

Any question concerning such problems will be gladly answered by Mr. Ost





through these columns, and readers should feel free to consult him at any time. Mr. Ost has worked at heavy forgings, general blacksmithing and tool making for over fifteen years and is especially well qualified to handle this subject.

somewhat deformed and when worked back into shape, it is slightly thinned. In theory no stock is lost by hammering, yet in practice an allowance must be made for the

“Ben Taylor has been with us for sixty years: Up until three years ago he could do his work as a grinder as well as any one. He refused to take a pension, and we put him on the door. He is just as good a doorman as he was a grinder”.

“Fred J. Smith has been straightening saws for fifty years and in the amount and quality of the work he does he is well up with the average of the younger men. Jake Noll, with fifty-two years of service behind him, is still doing the delicate work of blade-hardening as quickly as the men of half his age who work with him. George Harris has kept up his end as a blacksmith for fifty-four years. George Walker worked as a machinist for fifty years. Then his health began to fail and he asked to go on the pension

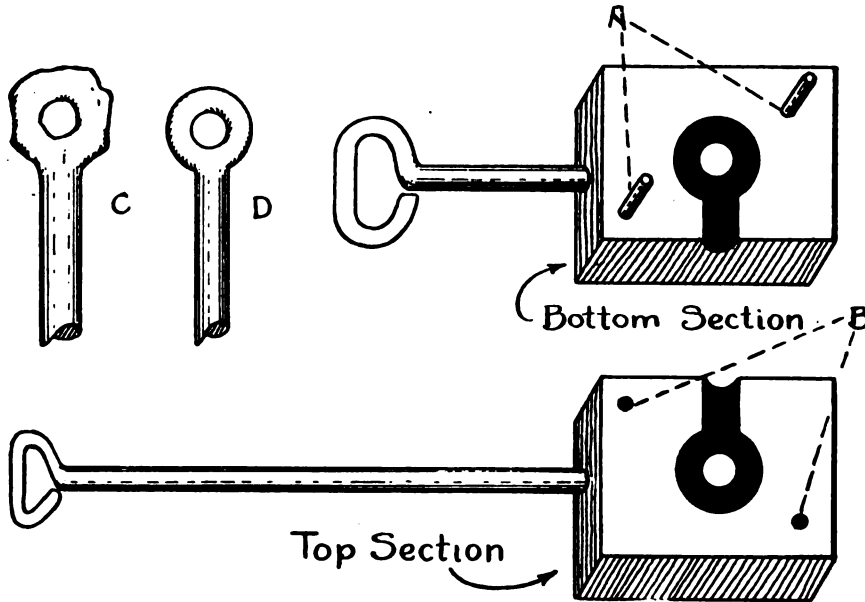

FIG. 4—HOT STAMP FOR MAKING EYE-BOLTS

Eyes and rings are often forged without welds, especially tool steel rings which are best when carefully forged solid. A flat bar is forged with the ends rounded. It is punched or split to form a slot, as shown in Figure 1. This is opened up by inserting a tapered mandrel and hammered to shape on the anvil horn. In calculating the amount of stock needed, we must determine the area of the ring; this is done by taking the area of the outside circle and subtracting the area of the inside circle from it, as shown in Figure 2.

thinning and stretching incident to shaping.

Allowing 1/2" stock for hammering, and taking material 1 1/2" wide, the amount of stock needed would be 10 3/14 divided by 1 1/2 or 6 7/8, the amount of stock required.

10 3/14 divided by 1 1/2 = 143/14 x 2/3 = 143/21 = 6 - 17/21, or for practice, 6 7/8, length of stock required. 6 7/8 - 1 1/4 = 5 5/8 length of punched slot.

The area of outside circle... 38 1/2  
The area of inside circle... 28 2/7

The area of the ring... 10 3/14

The area of the circle is obtained by multiplying the square of the radius by 3 1/7, or 3.1416. The radius of the outside circle is, of course, equal to 1/2 of the sum of the inside diameter plus the two thicknesses of iron.

3 1/2 x 3 1/2 x 3 1/7 = 7/2 x 7/2 x 22/7 = 77/2 = 38 1/2 which is the area of the outer circle.

3 x 3 x 3 1/7 = 28 2/7 the area of the inside circle.

38 1/2 - 28 2/7 = 10 3/14 area of ring.

The next step is to determine the amount of flat bar. The stock used should be twice the width of the side of the ring, to which may be added about 1/2" for the splitting. When the bar is split the stock is

### When is a Man Too Old for Useful Work?

“Every Week” asks: “When is a man too old?” Is it possible to establish an arbitrary age line at which a man is no longer able to

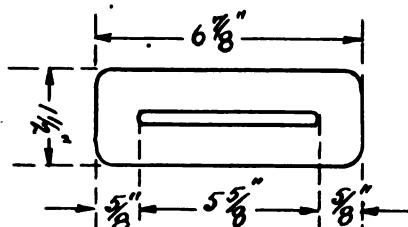

FIG. 1—DIMENSIONS FOR FLAT BAR USED IN FORGING WELDLESS RINGS

compete with the rising generation?

The examples of hundreds of fine old gentlemen still plugging away in the various crafts seem to contradict an affirmative answer to these queries. Consider the following cases:

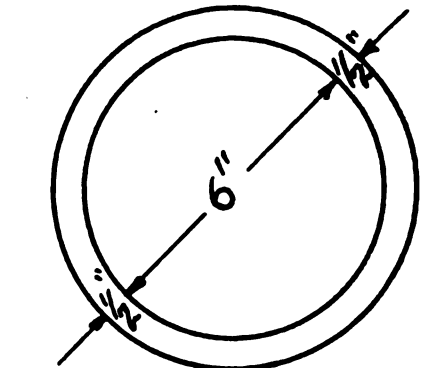

FIG. 2—TO DETERMINE AREA OF RING, SUBTRACT AREA OF INSIDE CIRCLE FROM THAT OF OUTSIDE CIRCLE

list; he bought himself a farm, and in two years had so recovered that he came back for his old job. He worked for another two years before he again went on pension.”

Eli Goucher, aged 70, and a widely known and respected blacksmith of Westboro, Mass., has just given up his blacksmithing business after working continually at his trade for 50 years.

In closing up the old shop, Mr. Goucher said to some of his friends:

“I have rounded out 50 years as a blacksmith, but the work is getting too hard. It is hard work shoeing horses, anyway, and especially so for a man when he reaches my age. I do not intend to remain idle, but will get work in Worcester in a machine shop or somewhere else where the work will not be so hard. There is a demand for men not so active as I am.”

After twelve long years on the police force—eight on the street and four as chief, Thomas Leyland has



returned to his old occupation behind the forge. For years, before becoming a member of the force, he conducted a blacksmith shop and was recognized as one of the best horseshoers in the business.

And we could go on relating innumerable cases that have come under our observation—dozens of "Our Folks" whose period of active service at the forge runs over two or more generations—men who "die with their boots on."

"The theory that a skilled mechanic is useless after he has passed the fifty-year mark is not based on fact. The older man can not always move about so rapidly as the younger man, but where the work requires care and skill without much physical activity I would take the older in preference to the younger man. The arbitrary scrapping of men because of age is a sheer waste of economic effort. 'Old age' we find, is a comparative term and is something more than years."

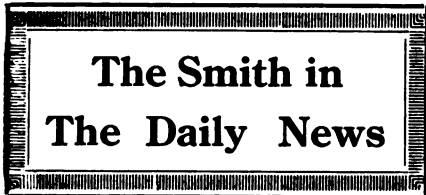

**Odd Mention of Anvil Ringers and Knights of the Forge in the News of the Day**

**Blacksmith Had a Safe, and It Was Mark of Thieves**

But pinned to the safe was key to combination and a paper on which was written:

"Not locked. Turn Knob to left and bar to right.

Open. Please close again and oblige."

Just where a blacksmith got hold of a safe and what possible use he could have for it is beyond our powers of imagination.

But J. B. Sterns of Oakdale, California, had one and it attracted the attention of burglars who entered his shop late one night, armed with enough explosives to destroy a bridge, for the purpose of blowing up the staunch iron box in order to secure his wealth.

Said wealth was like the watered stocks of Wall Street fame—mostly on paper and consisting mainly of records of what others owed him.

Imagine the chagrin and disappointment of the thieves!

**Sparks in Throat Excuse for Drinking**

"I'm a blacksmith your honor, and a few sparks got in my throat which I tried to put out by drinking beer," was the plea of Matthew O'Connor of Elizabeth, N. J., when arraigned in police court the other day. O'Connor had been arrested by Patrolman Kiernan while carrying the load which Kiernan testified was of the weight of an anvil.

The frank admission of the blacksmith won him freedom, Judge Mahon advising him to wear an asbestos muzzle in the future.

#### Seeks Divorce from Blacksmith

Because her husband, an anvil slugger of Brocton, Mass., was not content to do his work at the forge alone, but forced his wife to wield a 12-pound sledge and do other heavy work in his shop as well as the family housework, Mrs. Emily B. Bradley has applied for separation.

To our way of thinking, this is about the limit and Mrs. Bradley should be awarded a favorable verdict without delay.

#### Blacksmith Invents Binder Attachment

Andy Anderson, a blacksmith of Oklahoma City, Okla., has received a patent to a grain binder. His attachment connects to the sickle point, and is used to raise fallen grain. He has received a letter from a Canadian manufacturer asking him if he would consider an offer of \$50,000 for the rights to manufacture the attachment in the dominion.

#### Hand-Made Chains

In this day of machine manufacture, it will perhaps surprise some to learn that the making of big chains is largely, if not entirely, confined to methods dependent on hand labor. There are probably no big chains being made in the United States by the use of machinery. There are various appliances employed, but these are hand operated or personally controlled. This situation appears to be due to two things: First, as the proverbial expression has it, "a chain is no stronger than the weakest of its links." A hand-made chain is naturally made link by link. If the workmen are not only careful, but conscientious as to details, there is considerable opportunity for attention equivalent to continuous inspection. The making of big chains is largely an old time blacksmith's job and probably always will be.

#### Master Horseshoers to Buy Stock Direct

The Master Horseshoers' Association representing 31 cities and towns of Massachusetts, have appointed a committee to consider the matter of buying stock direct from the manufacturers. At present the price of stock varies in different parts of the State and better prices are expected by direct buying.

#### Blacksmith Battles with Auto Bandits

Robert H. Thompson, a husky son of Vulcan residing in Washington (state) is inclined to favor the good, old horse after all as the most favorable means of transportation now that he has an adventure in an auto which nearly ended his career.

He had taken what he supposed was a jitney—seeing three men inside, and expected to be quickly "flivvered" to his home. But on arriving at a bridge in an out-of-the-way section, the men promptly ordered him out of the car and proceeded to hold him up.

Thompson, being a man of no little courage and mighty sinews immediately gave fight and had the three of them staggering after a fifteen minutes' pitched battle, when the driver slugged him over the head with a crank and knocked him out.

They then made away with \$87.75 in cash, his watch and a wallet.

#### Drop Forge Men Pledge Support

Secretary of War Baker has just made public a resolution adopted by the American Drop Forge Association, in convention at Cleveland during June, at which it pledged its support to the government during the present crisis. The resolution follows:

"Be it resolved, that we, the members

of the American Drop Forge Association, do hereby pledge our facilities to the call of our national government, holding ourselves in readiness to supply our country's needs to the utmost extent of our capacity, giving preference to the requirements of our government in every case over all business."

#### Syracuse a Great City for Horses, Says Shoers

Despite the increasing use of the automobile, the rise in the price of iron and steel of 100 per cent and in labor of 30 per cent, the members of the Master Horseshoers' Protective Association of New York in annual session at Syracuse, N.Y., were optimistic in their plans for the future. Not only were the members of the association certain as they assembled for their twenty-fourth convention that there is a future for their profession, but they brought the information that Syracuse is one of the best horse cities in the State.

"Here in Syracuse," said C. J. McGinniss, national secretary, of Brooklyn, "all the shops are busy and very few, if any, have closed their doors because of the automobile. It is recognized as a great city for the horse."

Mr. McGinniss said it has been proven that the motor truck is not practical excepting for long hauls and that the horse will be kept in service for the short hauls, along with other phases of trucking.

He asserted that many of the big supply houses are establishing branches in the outlying districts in order to avoid long hauls and are using horses for deliveries from these branches.

Prof. H. Asmus of Cornell University, Mr. McGinniss and George E. Biddison of Baltimore, national vice-president, were among the speakers.

Prof. Asmus, well known to readers of the American Blacksmith, as one of the great leaders of his profession, went into great detail concerning the work being done at Cornell.

#### Jersey City's New Mayor Began Career As A Blacksmith's Helper

Ye grimy toilers of the forge, list to this tale and take heed for evermore of how you treat that youngster you call your helper!

Frank Hague, now wielding undisputed sway over the old-time political machine of Jersey City is no moneyed demagogue, but a worker of the world who began life in humble circumstances and has fought every step of the way to his present high position.

He is forty-three years old, and emerged from the Erie blacksmith shop in 1897 to run for local constable. He was elected and ten years later was appointed custodian of the City Hall where his independent political views rapidly pushed him into the lime light.

When the city changed its form of government into the newer and more progressive commission type, Mr. Hague was a leader in the fight. The victory of commission government found him the logical man for mayor and his election was the final blow that crushed the old-time political machine that had controlled the city's political destiny.

Frank Hague is a fighter—clean cut and aggressive. He believes in the principle of "no quarter" for his enemies, and it is this principle which has placed him where he is and which assures the citizens of Jersey City of a future of unparalled efficiency in the administration of the city government.



# The Kid Has Gone to the Colors

BY WILLIAM HERSHELL

The Kid has gone to the Colors  
 And we don't know what to say;  
 The Kid we have loved and cuddled  
 Stepped out for the Flag today.  
 We thought him a child, a baby,  
 With never a care at all,  
 But his country called him man-size  
 And the Kid has heard the call.

He paused to watch the recruiting  
 Where, fired by the fife and drum,  
 He bowed his head to Old Glory  
 And thought that it whispered: "Come!"  
 The Kid, not being a slacker,  
 Stood forth with patriot-joy  
 To add his name to the roster—  
 And God, we're proud of the boy!

The Kid has gone to the Colors;  
 It seems but a little while  
 Since he drilled a schoolboy army  
 In a truly martial style.  
 But now he's a man, a soldier,  
 And we lend him listening ear,  
 For his heart is a heart all loyal,  
 Unscourged by the curse of fear.

His dad, when he told him, shuddered,  
 His mother—God bless her!—cried;  
 Yet, blest with a mother-nature,  
 She wept with a mother-pride.  
 But he whose old shoulders straightened  
 Was Granddad—for memory ran  
 To years when he, too, a youngster,  
 Was changed by the Flag to a man.  
 —Indianapolis News.

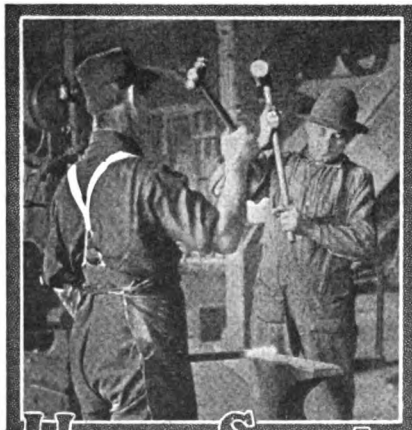

## Heats, Sparks, Welds

It's better to be a self starter than a crank.

Have you something to do tomorrow? Do it today.

Patriotism isn't measured by lung power, but by action.

He who thinks he knoweth it all has the most to learn.

The fellow who gets nothing but money out of his job is poorly paid.

Some folks are about as busy as an undertaker between funerals.

The man who doesn't mix kindness with business, leaves out one of the finest ingredients.

As ol' Si Perkins sez: "My idear of superfluity is one o' them hired shofers on a fordcar!"

"No", says ol' Si Hearsay, "It don't require no capital to start a rumor."—and Hearsay ought to know.

When a man complains to you that everybody steps on him, just hand him this: "It never happens to a live wire!"

The world is full of a number of men who never quite finish what they start out to do. Don't be merely a starter—be a finisher.

He's one of these chaps that ain't what he used to be—an' he never was!" So says Pete Burritt from his seat on the old cracker barrel. Could he say that about you?

Phil Osofy sez to us t'other day, sez he, "Sum fellers think they be t' architects of their own fortunes, but I ges' a good many of them must have dodged the building inspector."

An alarm clock will wake a man up—but he has to do the gettin' up himself. And one can read every word in his craft paper and it may wake him up to the live opportunities in his trade—but he has to stir himself to profit by them; reading alone will accomplish nothing if what one reads is not put into practice.

A sharper is a keen man with a dull conscience. There happen to be a few left in this country and once in awhile they happen along and drop into a smith shop with a "gold brick" which many a wily smith falls for. Just keep your eyes open next time you see one of them come.

Strive to do it better—better than your competitor and above all, better than you ever did before, and your reasonable success is assured. Why? Because such an overwhelming percentage of your competitors will not make the same effort; hence your success from a comparative standpoint is as sure as the rising of the sun.

Tom Witten says: "To be a good citizen one must first realize that he owes a duty to his community; second, he must be willing to perform that duty, and finally, he must fit himself so he knows how to perform it." And we might add that the same line of reasoning can be applied to the patriot, and to the craftsman.

We are told that in this war the farmer is fully as important as the soldier. This being true, the farmer's equipment must be kept up as well as the soldier's, and the man who does this is the blacksmith. Hence his obligation and his opportunity to be of service to his country is as great as that of the farmer or the soldier. With the extreme scarcity of iron and steel, farm implements must be conserved to the utmost and the responsibility of this conversation rests largely upon the able-bodied smith.

As Brother Andrews says: "Of all the nuisances that inhabit the earth, the whiner is the worst. It matters not whether he is the rich old miser who whines about taxes being too high, or the poor fellow who whines because he never had a chance and is oppressed—deliver me. I have kissed good-bye to my last penny on many occasions, and every day I see business going by my door that I ought to have—but thank God, I'm no whiner. What you and I don't get out of life is more your fault and mine than any one's else."

Tom Tardy don't believe in the following, but you can bet a good cigar against

an old horse shoe that we do; "Blessed is the man who has found his work to do"—but thrice blessed is he who has found a machine to do it for him!

The wise and up-to-date smith with his cost system doesn't do much worrying over his competitor who follows the stone-age rule-of-thumb methods. And he doesn't need to—for such a competitor is the easiest kind of a competitor to have.

It's poor economy to let your business system break you down physically. Which leads us to suggest that you, Mr. Man, take a vacation for a change. Even two or three days out in the open on God's dirt will do wonders for you, and it's something that no amount of argufying can convince us you can't afford.

Extra copies of the "Hot Weather Rules for Horses", which appeared in the last issue, may be had by writing to the Boston Work-Horse Relief Association whose office is at 15 Beacon St., Boston, Mass. Shoers who make it a point to hand out a few of these to their customers will be doing a good act for love of the faithful horse.

It has been proposed that automobile repairmen be required to take an examination for a license the same as veterinarians, the belief being that the owner of a car is no more justified in turning his machine over to an incompetent repairman than the possessor of a fine horse giving it into the charge of an unskilled vet or shoer. The same reasoning applies to both cases. What do you think reader? Let's have a few opinions on the subject.

Bill Bishop writes us as follows: "You may state in Our Journal that any greasy-handed son of Vulcan that wishes to ask any question concerning power hammers, or wishes a clearer explanation of anything set forth in my articles on this subject, may have any information at my disposal by writing to your office or direct to me." We take this opportunity to thank Brother Bishop for his kindness and his interest in our Folks. Long may he wave!

### Horseshoes and Preparedness

Recognizing that the conservation of the army horse depends largely on their scientific shoeing, the Michigan State Association of Master Horseshoers at its 24th annual convention in Grand Rapids, pledged its staunch support to the government in the following resolution:

"Approving our government's efforts for a greater and more efficient preparedness, we pledge our unyielding loyalty and service to our country to the end that our horses may be equipped with the intelligent care and skill requisite for their greater service in any emergency that may arise."

At the convention the association discussed a plan to establish a class for the study of the anatomy of the horse at the Michigan agricultural college.

It was decided that at the next session of the legislature the association will make an effort to secure the passage of a bill requiring an examination for horseshoers.

Data to correct the erroneous impression that the rapidly increasing popularity of the automobile spelled doom for the horseshoeing business was furnished at the opening session in the form of a government report showing that there are 5,000,000 more head of horses on the farms of the country alone than there were 10 years ago.

Our Honor Roll

AS GOOD AS A BOND!

That's what one reader says about his long-time subscription. It is an investment that pays for itself over and over again. Interest is paid monthly—and at a liberal rate—for every issue of "Our Journal," that is read by you adds just so much to your stock of craft knowledge. One could not ask for better security for his money. The "Blacksmith" is no new thing; it is an established craft institution. Then the conversion privilege is a feature worth considering. If you die before your subscription has expired, your family receives the balance due at your death.

A long-time subscription is an investment well worth your thoughtful attention. Read the rates below. Notice how much actual cash you can save—and get busy today.

KANSAS STILL UNDEFEATED CHAMPION

The title is still held by fighting Krehbiel of Kansas, but the ring is open to all comers. Who's next? Just keep your eye peeled and see who is going up against him to contest the title for his state.

U. S. and Mexico Canada Other Countries.

Table with 4 columns: Duration (2 yrs, 3 yrs, 4 yrs, 5 yrs, 10 yrs), U.S. and Mexico rates, Canada rates, and Other Countries rates.

Send your order and remittance now—today. Don't wait until you forget all about it. You'll never regret it. Our subscription insurance saves you money. The sooner you begin saving, the more you save. There is no better time than NOW.

Subscription list for U.S. and Mexico, Canada, and Other Countries, including names and dates.

Subscription list for U.S. and Mexico, Canada, and Other Countries, including names and dates.

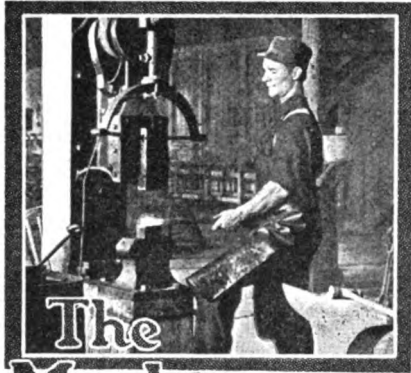

# The Machine and Tool Smith

## Bending Steel Bars

JAMES STEELMAN

THE blacksmith is called upon to do a good deal of bending of bars, rods and tubes. The tire for a carriage wheel affords a familiar example where solid stock has to be bent, in automobile repair work there is considerable rod and tube bending, and so on. Let us begin with solid bars.

When the smith is required to prepare a tire for a wheel or a hoop for a wooden water tank or some similar article, he will at the outset need to know how long a piece will be required. Suppose he is furnished with the diameter of the wheel or tank or other body that the ring of steel is to surround. This will be, accordingly, the *inside diameter* of the *ring* or *hoop*. Naturally, the outside diameter will be the inside plus *twice* the thickness of the stock. The thing to do is to consider that he will need, for a circle, a length equal to the circumference of the circle whose diameter is the *inside diameter plus once the thickness of the stock*, which extra length has to be allowed for making the weld.

Now to find the length of the circumference when we know the diameter, multiply the diameter by 3 1/7, or, what is the same thing, by 22/7. For example, suppose we have 1/4-inch flat stock which is to be bent around a tank 4 1/2 feet in diameter. Note, first of all, that we have the thickness of the stock given in *inches*, while the diameter is given in *feet*. We will need, sooner or later, to have both in inches or both in feet. Suppose, then, we turn the 4 1/2 feet into inches. We get 54 inches as the equivalent. Our problem will now appear as follows:

How long a piece of stock 1/4 inch thick will be required to make a hoop for a 54-inch tank?

We take the *inside diameter* of the hoop and add *once the thickness of the stock*. That is what our rule says. Accordingly, we take 54 inches and add 1/4 inch, thus getting 54 1/4 inches. The next thing is to find the *circumference* of a circle which has 54 1/4 inches for its diameter. To do this we multiply, as we are directed, the 54 1/4 inches by 3 1/7. The easiest way to do this is to trade off 54 1/4 for its equivalent 217/4, and 3 1/7 for its equivalent 22/7. We are then ready to multiply.

$$\frac{31}{4} \times \frac{22}{7} = \frac{682}{28} = 24 \frac{10}{7} = 24 \frac{2}{7} = 24 \frac{2}{7} \text{ inches}$$

Reducing this to feet, by dividing by 12, we get 14 feet 2 2/7 inches. That is to say, we shall need a piece of stock this long to form the circle.

However, to make a hoop, we will want more than to merely make the edges meet. We will need enough material for a weld. Whatever allowance is to be made for this purpose is to be added on. Blacksmiths will differ as to the amount this should be. It is unnecessary for me to decide, as each smith should be able to estimate for himself how much allowance he is going to want. Suppose, however, that 1/2 inch is deemed right for the present job. Then the piece of stock should be cut off so as to provide a piece 14 feet 3 inches long. If 1/2 inch is too

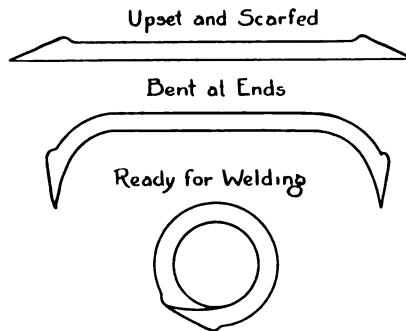

FIG. 1 — THE THREE SUCCESSIVE STEPS IN WELDING A RING AS DESCRIBED BY MR. STEELMAN

much and 1/4 is really enough, then the straight bar is to be 14 feet 2 3/4 inches in length instead. In a good many cases, the allowance for the weld will be satisfactory if it is made the thickness of the stock. The *width* of the stock has nothing to do with this matter.

We next upset both ends for a short distance. How far back we upset will naturally depend upon the thickness of the stock. Possibly we shall not be far wrong if we upset each end back a distance equal to *double* the thickness of the steel. However, this is something on which blacksmiths will differ.

After upsetting, we proceed to *scarf* the ends for the purpose of making a lap weld.

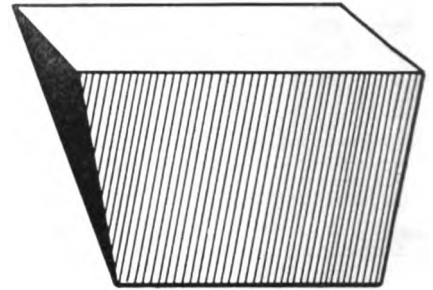

FIG. 2 — A DUTCHMAN

The foregoing directions have in mind the usual method of uniting the ends of a ring. The oxy-acetylene process of "welding" has, however, introduced a new mode of making a joint. If the purpose for which the ring is to be used permits of oxy-acetylene welding and the smith is equipped to handle the work in this way, then we must make some changes in our calculations. We will suppose, first, that we are going to make a simple V-shaped weld, the weld being made from one side only. As before, we add once the thickness of the stock to the diameter of the inside of the ring, and then calculate the circumference corresponding to this new diameter. We get, as before, 170 1/2 inches, or 14 feet 2 1/2 inches. This then is the length of stock we are to use. Let it be noted that no allowance is to be made for the weld. The reason for this is that we are going to *add new material* in the welding process. There will perhaps be no need to do any beveling of the edges. This can be determined when the strip is bent round and two inside edges brought into contact. When this is done, there will be formed a V-shaped groove without any attention from the smith. The only question will be whether the groove is sufficiently open. If the stock is thick for the size of the ring, then the V will be spread more than would otherwise be the case. But, if the stock is thin and the circle large, the groove may be pretty sharp. The best short rule that can

be given perhaps is this: If the V-shaped groove is much less than a right angle, let enough beveling be done to secure the full 90 degrees.

In case beveling needs to be done, let the smith remember that he must not lengthen the inside circumference by hammering out the bevels. He may avoid this lengthening in two ways. First, he may shorten the piece of stock by cutting off from one end a piece equal in length to the thickness of the stock. He then uses his hammer and bevels both ends, making each bevel a 45-degree slope. In doing this, he must be careful that the ends are not thickened. If they become thicken-



FIG. 3—A SPLIT WELD

en in the work of beveling, he may correct such thickening. Or, he may allow for such thickening by cutting off less than one thickness of the metal before beginning the beveling. The second method, contemplates a thickened joint. Instead of cutting anything preparatory to beveling, the smith proceeds to effect a shortening by upsetting both ends. The amount of upsetting to do is to be reckoned as enough to make the length of the strip *before beveling* just equal to the required inside circumference—perhaps a trifle shorter than this. The test that will show whether the shortening has been done correctly—whether he shortens by cutting or by upsetting is the length of the *inside side* of the stock *after* beveling is completed. This length should be that of the inside circumference required.

We will now suppose that we have the stock bent to shape and that the inside circumference and inside diameter are *both* what they are expected to be at the finish. We will also suppose that we have a V-shaped groove opening from the inside side of the ring towards the outside. And further, we will suppose this groove either to be of full 90-degree size or else to be sufficiently open to do the welding.

The object of a groove in oxy-acetylene welding is to make it possible to get the tip of the little white working flame down to the bottom of the metal to be joined or else very near the bottom. The 90-degree groove seems to provide for

this in good shape. But narrower grooves may be used by the more skillful welders, if they remember what they have to do. That is, if they remember that the old metal of the work is to be brought to a soft condition clear down to the bottom of the V, and that the new metal of the welding rod is to be *melted* and *mingled* with this old metal in the softened state. Often, work may be turned over, and the torch applied along the weld, more or less new metal being added.

If it is permissible to have a swelling on both the inside and the outside of the ring at the weld, we may weld by means of a double V, the two V's being arranged point to point, one of them being upside down. That is to say, we double-bevel each end of the stock and bring the two ends together for welding by the torch and welding rod.

The material to use for filling up the grooves is Norway iron, or some equally good iron that has little or no carbon in it.

When making an oxy-acetylene weld, the two ends of the work should be held rigidly to position by clamps or a similar device.

It should be remembered that an oxy-acetylene weld is ordinarily less strong than the material which has not been highly heated. This loss of strength is no doubt due in large part to the high temperatures. Steel when heated to the higher temperatures undergoes a change in its internal condition. The grains become

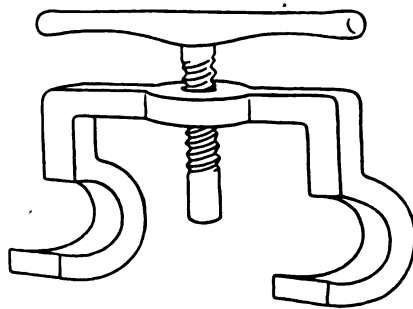

FIG. 4—A JIM CROW. THE HOOKS AND SCREW ARE SO RELATED THAT IF A BAR IS LAID ACROSS THE HOOKS THE SCREW WILL COME DOWN FAIR AND SQUARE UPON IT

larger and remain larger than they should be under proper conditions. Such steel with its enlarged grains is weaker. That is, it will not stand, per square inch of cross-section, the same amount of pull. One way of correcting the loss of strength in an oxy-acetylene weld is to make the weld thicker than the material is

elsewhere. We may carry this thickening quite a ways, since we have only to add on new material and

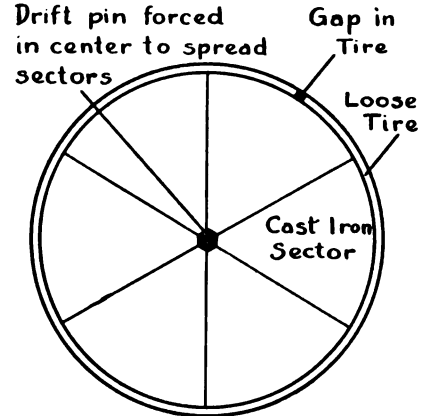

FIG. 5—FOR COLD BENDING SMALL JOBS

make sure it grips the metal to which it is added. There will be cases, however, where such thickening is not permissible, because of its appearance or for other reasons. Oxy-acetylene welds can, no doubt, be improved in strength, if the steel is properly annealed. The oxy-acetylene flame consists of an outer envelope in addition to the little inner white cone. Some operators use this large, outer flame as a means of annealing. It seems doubtful whether much reliance should be placed upon this procedure, unless the operator has a good deal of experience in annealing by this method.

However, here is the place where the blacksmith who goes in for oxy-acetylene welding ought to shine. The smith is supposed to have knowledge and experience in hardening, tempering and annealing. So then, if the smith will use this outer flame just as he would a furnace fire and expect nothing more from it, he may be expected to get good results. I can hardly give much space to this matter in the present article, and will content myself with calling attention to one or two points.

In the first place, do not attempt to anneal with the outer flame until the work has been allowed to cool off, say, to a black heat, weld and all.

Then do not be in a hurry, but apply the torch so as to cover the weld everywhere at the same time and in fact so as to cover all the region that has been heated, say, to redness. Seek now to manage matters so as to raise the temperature slowly—two objects being in view. One object is to heat the



work through and through. The other is to avoid getting the temperature in one part much higher than in another. After the work is

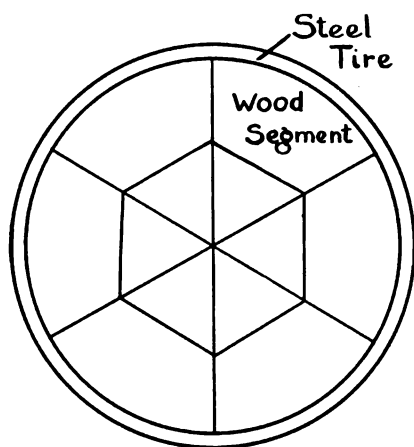

FIG. 6—FOR COLD BENDING LARGER WORK

brought to the proper annealing heat, hold this temperature. This is the difficult thing with a torch. If the work can be done late in the day and buried in slaked lime, asbestos, sand, or the like over night, then we may hope for good results.

The smith should not overlook the fact that even with welds made by the old-time methods, there are apt to be weaknesses. The hammering on the weld itself, if not done at too low a heat, undoubtedly benefits the material reached by the blows of the hammer. It will often be difficult, however, to make the blows reach through and through. The regions to either side of the weld, the smith is sometimes apt to overlook. Hammer working breaks up the grains and forces them to a rearrangement. This is good for the metal. But highly heated regions to either side of the weld, if overlooked, will have

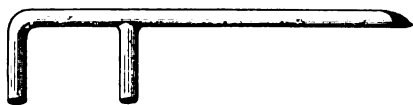

FIG. 7—A TOOL FOR BENDING

big grains at the finish, because of the high heats experienced. The thing to do, then, is to make sure that the hammering has reached everywhere that the high temperatures have been and that no hammering is done upon comparatively cool metal.

A method of welding along old-time methods, but involving a departure in connection with the method of forming the scarfed ends, is recommended by Sallows. See

Fig. 1. Ordinarily, the smith will scarf one end then turn the work over to scarf the other end. It is advised not to turn the work over; but to bevel the scarfs from one side only. Naturally, the ends will be upset before scarfing. When the piece of straight stock has been scarfed at both ends, it is bent near each of those ends. We are now beginning to form the ring. It is important to bend in the right direction. When the work is lying flat with the scarf bevels up, the stock will be longer underneath than on top. We bend *downwards*. That is, the hollow of each curve is on the long side of the stock and the convexity on the short side. When the weld is made, the scarfed surface of one of the bevels will form part of the outside surface of the ring.

Another method of effecting the joint is to make one end the shape of a wedge and to split the other to a form suited to receive the wedge. We probably get greater surfaces of contact in this way, which may perhaps be some advantage.

Sometimes, after cutting off the stock, we find the piece too short. We may already have made the weld. We may nevertheless lengthen the piece by the use of one or more "dutchmen". A dutchman is a kind of wedge which one drives into the steel with the object of leaving it in, and, in fact, of welding it in. We make a wedge form of suitable material—same as the work—and then taper it slightly on either side. See Fig. 2. If we have a ring which requires more metal, we may heat it up at some convenient point. We then use a hot chisel to form a wedge-shaped opening for the dutchman. If the bar has already been bent and the weld formed, it will be well perhaps, to put the dutchman on the outside. Be that as it may, we drive the dutchman in cold. We now heat the region concerned to the *welding point*. It is recommended not to drive the dutchman in further than one-fourth the diameter of the work. We then get added material in the bar, which will naturally permit us to lengthen it a bit. If still more material is needed, we may drive in another dutchman from the other side. If, however, we have made a good big error in cutting off the stock and so need a good deal extra material, we will find it easier perhaps to cut the work in two and weld in a piece.

A recommended form of union

for the ends of a ring is given on the authority of Moore. See Fig. 3. After the stock has been cut off to the proper length, we proceed to scarf the two ends. But we do *no upsetting* as a preliminary to the scarfing. In fact, whatever upsetting takes place during the whole procedure occurs automatically and requires no attention on our part. After scarfing the ends we slit them in the middle. Each slit divides the *width* of the scarf end into two parts. Care should be taken not to run the slit back into the stock more than a trifle beyond the rear of the scarf. We then bend the scarfed end, one half in towards the inside of the ring to be and the other half to the outside of the ring to be. We deal with the other end of the piece of stock in the same way. Only, we are careful in bending the halves of the second end, that we shall have an interlocking joint when the two ends are brought together. The only mistake we can make here is to bend the half out that should be

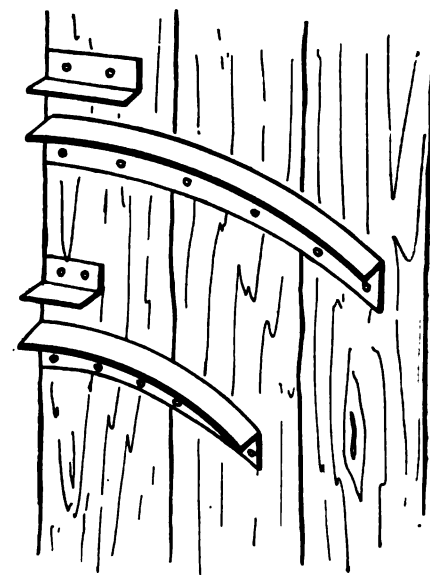

FIG. 8—TWO CURVES OF ANGLE-BARS. UPPER IS SHAPED ON A LONGER RADIUS THAN LOWER. THE TWO SMALLER PIECES ARE SHORT SECTIONS OF ANGLE-BARS. ALL FOUR ARE SECURED AGAINST A WOODEN WALL

bent in and the half in that should be bent out. When the two ends are brought together, we will soon see if we have done the wrong thing. If we have, it can soon be corrected. After the ring is bent and the ends brought fairly to position, we use a jim crow or rail bender in the following way. On the other side of the ring from the joint, we apply the jim crow in such a way as to



have the screw on the *inside* of the ring. We then turn the screw, forcing it against the inside surface of the ring. By tightening the screw, we cause the ends of the ring to jam each other. This is the effect wanted. We now heat the joint and proceed to make the weld, the jim crow remaining on the job all the time. See Fig. 4 for jim crow.

In a good deal of the foregoing, bending is required. This is an important matter, and one that should have our careful attention. There are more or less elaborate means for bending. Perhaps the best is a combination of three rolls, one roll working on one side of the work and the remaining two on the other side. But the fact that no such machine is in our shop need not discourage us, as there are other good ways of bending bar steel, though perhaps not so rapid and uniform in action.

Some work may be bent cold, especially if the steel is ductile. This should be the case, if the steel has a low carbon content. However, a good deal depends on the *purity* of the metal, as impurities may affect the bending quality of the material. If the diameter of the stock is very small as compared with the diameter of the bend, cold bending may be done pretty generally. For example, every time a hoisting rope runs over the drum or a sheave, we have a case of cold bending. The individual wires which go to make up the rope are each bent round the curve of the drum or the sheave. But the diameter of the wire (not the diameter of the rope) is very small indeed, when compared with

alone, and heat up his work and make his curve with hot material. If the rings are quite small, a cast-iron cone may be used to finish the rounding after the work has been roughly bent to shape and the weld made and completed. A very good method is to use cast-iron segments. See Fig. 5. These will all be alike and may very conveniently be six in number. In this case, each will be an equilateral triangle, only one vertex will be cut off and the side opposite will belly out a little to form an arc of a circle. We may lay off such a sector in the following way. First, lay off with the compasses a circle. Then draw a radius from the center to any convenient point on the circumference. Next, put the tip of one leg of the compasses on this point and make a mark on the circumference with the tip of the other leg. Join this point with the center. We now have the sector, except that we need to cut off the vertex near the center of the circle. The idea is to lay six of these to form a circle with a hole in the center. We lay the ring which is to be rounded on the table and place the six-sectors in place within it. By using a suitable *drift pin* in the center opening and driving the pin with a suitable hammer, we may force the ring to shape. We may use this device for several sizes of rings by employing bent pieces of wrought iron to fit in between the outer curved edges of the segments and the inner surface of the work. These methods are scarcely suited for larger work. Besides for heavy work, we need some way of doing the bending.

A good scheme is to use an iron ring or shell of the proper size and bend the work round this as round a kind of mandrel. If we have no such ring, we may need to construct one. If the diameter required is quite large, it will be economical perhaps to use wood. We may assemble sections of heavy boards and construct a suitable circle, using a wood turning lathe to get a good curve after the parts are secured together. See Fig. 6. The diameter of this curve should be enough less than the one required to permit of a band of steel to be put round the wooden circle. This band is needed to protect the wood against heat. After we have made our "wheel" and put on our "tire", we lay the whole device flat on the table where we propose to do the actual bending. Naturally, there should

be protection on the table against the hot work that is to be done. We secure the wheel firmly in place. Next, we arrange a stud or stop at a convenient point near the outer rim.

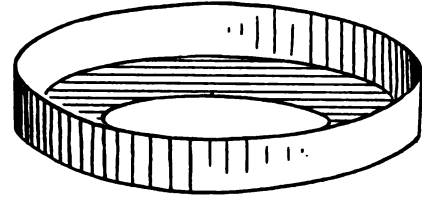

FIG. 10—ANGLE-IRON BENT TO A CIRCLE

The idea is to insert one end of the bar to be bent between this stud and the rim and then to force the work to bend against the latter while the former holds it in place. We may insert a flat, or slightly tapered piece between the work and the stud, if it seems best. By its use, we are able to provide a tight fit for the end of the work. We now need a suitable tool to force the heated work to bend against the rim. This the blacksmith can easily make for himself. See Fig. 7. He takes a piece of round steel bar and bends one end sharply to form a right angle. This gives a kind of hook at the end. The length of this piece will be perhaps a trifle greater than the depth of the ring to be bent. Then a short distance from this projection, the smith arranges another by welding on a piece or by any other convenient means. This projection will be parallel to the one at the end and equal to it in length. The inside distance between these projections should be distinctly greater than the thickness of the wooden wheel—measured in the direction of a spoke—plus the thickness of the work. The object in view is to use this lever or crow bar in such way as to have the end projection up against the inside of the wooden "felloe" while the other one may be brought to bear against the *outer* surface of the work. This lever will then be used to bend the work, a little being done at a time. It would seem possible to work pretty rapidly with such a lever. It will not be necessary to have room to permit the lever to be worked clear around the wooden wheel. After the work of bending has gone on, say for one-third of a complete turn, we may rearrange the work so as to have the stud and wedge to bear against the last inch or so that has been curved. It may seem best to make the wooden ring a little more perfect and bring the interior

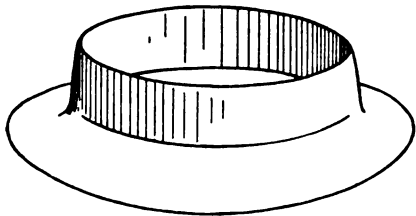

FIG. 9—A PIECE OF ANGLE-BAR BENT TO A CIRCLE

the sheave or drum diameter. Such cold bending may be done repeatedly, times almost without number, and rapidly too without seriously affecting the wires, *provided the diameters are exceedingly different*. We must remember, in case we think of imitating these bends, that the material is very perfect—very free from impurities.

Generally, the blacksmith will do well to let cold bending pretty well





to something like a circle. The reason for this is to give uniform action to the lever. Otherwise, we should perhaps have the projection which performs the bending action,

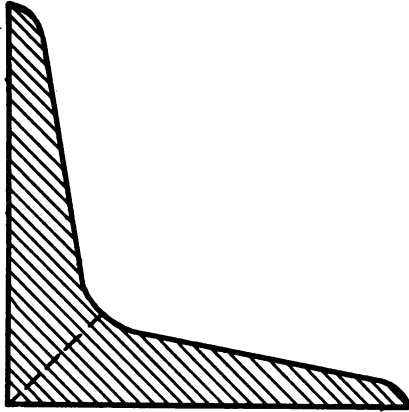

FIG. 11—CROSS-SECTION OF ANGLE-BAR. NOTE EXTRA THICKNESS AT DOTTED LINE

now with a short length of work, now with a long length. The smith may find, too, that it is advisable to give the projection which comes against the work a contact surface rather broad and rather flat to avoid indenting the heated metal. The need for this will probably vary with the heaviness of the stock, the sharpness of the curvature, etc. In a great many cases, a plain round projection will be all right. In case, a broad and flattened surface is needed, it should be made slightly convex so as to roll somewhat on the work. It should be pointed out that the whole circle is not needed for the wheel. In fact, an arc of 60 or 90 degrees may be found ample. Naturally, in such case, the work has to be re-set as the bending proceeds.

An excellent circular form may be made from *angle bar*. This is bent in such way as to have the outside, flat surface of one flange in a single plane, and to have the outside surface of the other convex. The arc may be made 45, 60 or 90 degrees in length. See Fig. 8. The flange which remains in the same plane may then be utilized as a means of bolting the form to the table, suitable bolt holes having been arranged in it and in the table top. The stop may be another piece of angle bar, the piece being two or three inches long, and having when in place a flat side of a flange for the work to press against. These two pieces of angle bar may, if desired, be arranged on the side of the shop. Further, we may readily have several different curves and arrange

them one above the other. Thus, one may be curved to a 15-inch radius, the next above to an 18-inch radius, and the next above that to a 21-inch radius, and so on.

Where a flat bar is to be bent edgewise or an angle bar is to be bent, we may at times need to use a bending device suited to the bending of tubes, making some slight changes. This matter is to be treated in connection with tube bending.

It may be well to state here, however, how one may calculate the length of the stock needed to make an angle-bar ring. Two cases will arise: (1) where the outside flat surface of one flange becomes the inner, cylindrical surface of the finished ring (Fig. 9), and, (2) where the outside flat surface of one flange becomes the outer cylindrical surface of the finished ring (Fig. 10).

Case 1. Here we add to the inner diameter of the completed ring twice the maximum thickness of the root of angle bar. This thickness is shown by a dotted line in Fig. 11. We now have a length which we use, as a diameter and calculate the corresponding circumference by multiplying by  $22/7$ . To the length thus calculated we make a rather generous addition to cover upsetting and all other matters.

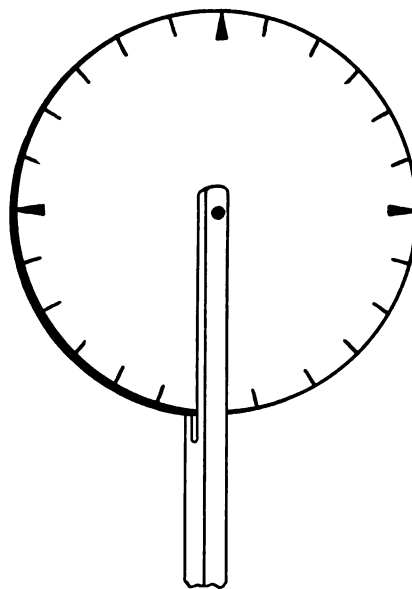

FIG. 12—A CIRCULAR RULE

Case 2. We proceed as in Case 1, only we use the *outside* diameter of the finished ring and *subtract* twice the maximum thickness of the root.

In order to test before welding whether we have just the right amount of material for an angle-bar ring or for any style, we may use what is known as a *circular rule*.

(See Fig. 12). This consists of a thin wheel or disk whose circumference is, say, just 2 feet long and on which has been properly marked the inches and fractions. This disk is mounted between the two prongs of a split handle so that it may readily turn on its center. With this simple instrument, we may measure the unfinished ring and often indeed the place where the ring is ultimately to go.

## The Oxy-Acetylene Plant—6

Its Installation, Operation, and Torch Manipulation

DAVID BAXTER  
Filler Rods

The *filler*, or new metal, is so called because it is used to fill in the groove or crack in the broken parts. It is also used to reinforce the joint where two pieces of metal are welded together. It is usually in the form of round rods, or more strictly speaking, wires. It is not necessary for them to be exactly round; they may be flat, square, hexagon, etc. Some attempt has been made to construct filler rods having a core of flux through the center, but this is needlessly expensive.

A filler may be easily made of several finer wires twisted together. This is done when there is no heavier size on hand, or for the purpose of combining metals. However, a full supply of sizes should always be kept on hand, as it is best to use different sizes on different classes of work.

Before lighting the torch, an operator should have the filler rods in readiness. He should choose the filler best suited to the work in regard to the kind of metal needed, and the size of the rod, and thickness of the work.

A large rod on a small job will melt comparatively slowly; it is in danger of burning, and renders it difficult to keep a supply of melted metal in the weld. On the other hand a small rod on a large, heavy job will give the opposite result—too great a supply of metal for the slower melting weld, thus making it easy for the metal of the rod to burn.

The rod of new material should be kept in contact with the weld (Fig. 3). This tends to keep the rod cool, as it allows the heat to pass into the weld, which is of benefit as it assists in welding. The end kept in the bath of molten metal helps to prevent the danger of burning the metal in the rod as the heat passes to the weld;



much heat being lost in many cases by radiation and conduction.

In an over-head welding, or perpendicular welding, the filler can not be kept in contact with the weld, because this would cause the melted metal to run or drip. In over-head welding the filler is not held in the bath longer than is absolutely necessary; in fact it is barely touched to the weld: just long enough to melt a drop of metal onto the weld, then quickly removed. By a clever manipulation of the torch and filler a very good over-head weld can be made. (Fig. 2).

The kind of welding rod does not always have to be the same as the parts to be welded, but may differ radically. Some times it is better to use a filler of an altogether different kind of metal. If one is required to weld a very small iron casting—say one weighing less than a pound, he can do a very satisfactory job if he uses a brass filler, because the brass will melt without the danger of melting either the casting or the filler. A good grade of so called Norway iron wire, is most commonly used for all kinds of small steel and wrought iron castings. Unless an operator is expert he should not attempt to use steel alloys except for experimental purposes.

All of the different kinds of metal may be joined together by the oxy-acetylene process, brass to iron, iron to steel, steel to copper, and so on down the line. If metals of entirely different nature are to be welded,

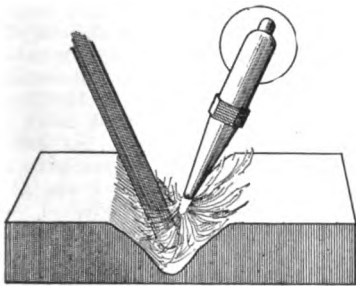

FIG. 1—KEEP THE ROD IN CONTACT WITH WELD AT ALL TIMES WHILE WORKING

choose a filling-rod whose melting temperature is the same as that of the lower one to be welded. For instance: if we are to weld a piece of aluminum to a piece of iron, we choose an aluminum filler, because the aluminum has the lower melting point.

In estimating the size of the filling-rod, a very good way to tell the best size is to measure the thickness of the section to be welded and

choose a rod of this diameter; but this rule does not hold for work over half an inch thick. For work over half an inch thick, a rod not over half an inch in diameter is big enough. In fact, this size will furnish new metal about as fast as it can be used on any job, and is seldom used in the average repair shop.

Sometimes, in sheet-metal welding, we are able to get a strip of metal sheared off one end of the sheets to use as a filler. But this is not essential, as a wire of Norway iron is almost as good. The filler in sheet metal welding is often used to knead or puddle the sheets together. That is, it is pressed along on the welded seam as the welding is being done. If the operator is careful in handling the filler and flame, a very nice piece of work can be done. In fact, the sheet-metal welds make the ideal ones—at least so far as the appearance is concerned. In appearance it is as though it were soldered. The rippled appearance may be done so nicely that the ripples seemed to be measured, they are so symmetrical.

When welding aluminum castings, it frequently occurs that the zinc, in the alloy used to cast the piece, is burned out by the welding flame, on account of the very low melting point of the zinc; therefore, the aluminum welding rod should contain a little extra zinc to replace it.

A welding plant operated in connection with a foundry can have its own filler-rods cast. The use of good judgment and a knowledge of metals will admit of making first-class fillers. A plant having no foundry can at least make filler-rods of the easier melted metals, such as aluminum and copper alloys. Make molds in moist earth by bedding-in rods of the desired size. After withdrawing the rods, fill the holes with the melted metal.

Aluminum is readily melted in a common babbitt ladle on a blacksmith forge. Bring the ladle and metal to a red heat slowly and hold this heat until the metal runs. It often takes twenty to thirty minutes to reduce the metal to a running state. It takes on a cheesy crumbly appearance before it reaches the fluid state. Do not hurry or you will burn a hole in the ladle or perhaps burn the aluminum.

Copper alloys may be melted on a forge by walling up around the fire with brick to a height of sixteen or eighteen inches, but a babbitt ladle cannot be used in this case. A graphite crucible must be used, as the iron ladle would be burned up before

the metal begins to melt. The melting process requires a great deal of patience for the novice. The principal thing is to keep the fire very hot under and around the crucible. The

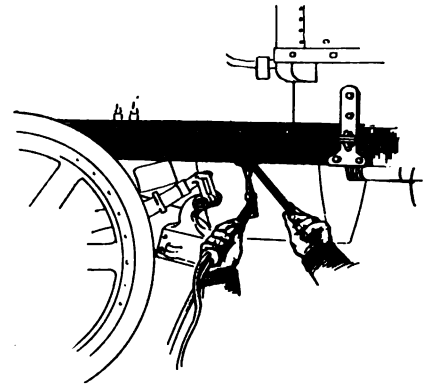

FIG. 2—A TYPICAL OVERHEAD WELDING JOB WHICH REQUIRES SPECIAL CARE AND SKILL

copper alloy is ready to pour when it will no longer cling to an iron rod dipped into it.

Home made cast-iron fillers of good quality can be made if care is exercised in molding, and a soft grade of iron poured into them. A great many foundries have trouble in producing soft clean cast-iron filler-rods. I find this due mostly to one mistake. This mistake is made in the molding. Most foundries sacrifice in order to produce in quantity. They either attempt to do it by punching a box of sand full of holes, or else bed a large number of rods in a mold and pull them out sidewise. It is this pulling the pattern rods out of the molding sand that does the damage. When the rod is withdrawn from the mold, it causes the sides of the mold to be slick and hard. The slick, hard surface causes the melted metal to boil and to cool, causing a very hard white rod, or at least with a white, hard shell around the rod. The remedy: mold the rods in a two-piece mold, ram the sand gently and lift the patterns out sidewise without swabbing. Pour them with a soft high-silicon iron and you will have a rod satisfactory for welding. These rules are the same for all metals but are more important for cast-iron on account of its hardening propensities.

(To be Continued)

**To Detect Cracks in Fine Tools—** Here's a stunt that comes in handy in rendering visible tiny cracks in tools and other hard steels. Moisten the surface with kerosene oil and rub dry with a rag. Then rub in powdered chalk and after a few moments look for traces of grease in the chalk. Wherever they appear it indicates the presence of a fine crack in the metal—which in some cases may prove disastrous.



### Benton's Recipe Book

**To Remove Old Oil, Paint or Varnish—** This is a problem that has taxed the patience of nearly every one who has ever had occasion to do refinishing. Benton described two effective methods this month that will be found to be great time and labor savers:

1—Mix up about five parts of potassium silicate (water glass, 36%) with about 1 part soda lye (40%) and 1 part ammonia. Apply well over the surface of the old paint or varnish and leave until well softened. The old coatings may then be removed with a stiff brush or left for several days in a hardened state after which they will come off quickly by moistening thoroughly with water. This mixture dissolves right down to the bottom.

2—One part oil of turpentine mixed with two parts ammonia will do the work where even the strongest lye fails. Shake well in a bottle before using, until the liquids mix like milk. Apply with an oakum swab and wash off the old paint in a few minutes.



### Queries—Answers—Notes

**An Old Friend Back in the Craft Again**—I used to take the American Blacksmith but gave it up when I started farming. Now I am going back to blacksmithing and feel that I need my magazine again.

Peter Hartner, Michigan.

**Wants Suggestions Concerning Side Lines**—I am a new subscriber, but already I have found a great deal of good reading in your paper and of the many receipts, one has proven worth more than the subscription price.

I am running a shop in a rural district and want to carry a side line suitable for this section. We raise mostly cotton, sugar cane and maize hereabouts, so that will give you an idea as to what we would use.

I hope some brother smiths who have had success with side lines will advise me through these columns. Yours for better blacksmithing.

E. B. DRUBY, Texas.

**Who Can Supply this Crank Shaft?**—Mr. C. M. Beers of Cataula, Georgia, writes in and asks us if we can help him secure a new or second-hand crank shaft for a 1909 or 1910 Oswald Motor such as was used in the Halladay cars of the same date. Apparently no auto supply house carries this type and model any more, and as Mr. Beers has a car in first class condition, excepting for the crank shaft, he will greatly appreciate any assistance in this direction and substantially compensate anyone who can help him.

There must be hundreds of these cars in various parts of the country, and no doubt many have been ready to junk for several years. Possibly someone has one and would be willing to sell the shaft if he could realize something on it and junk the rest or use the remaining good parts in connection with other repair jobs. Anyone who can help Mr. Beers should write him direct to the above address.

S. S. New York.

**From a Subscriber in Florida**—I am not much of a writer, but as you want to hear from readers everywhere I guess it is a duty as well as a pleasure to tell you something about we crackers down here in Florida. We have been taking the paper about three years and have found many important helps in its columns. We think your article in the June number, which admonishes us to get together, is fine. That is one point we are short on as a profession. Merchants, carpenters, bricklayers and nearly every other trade and profession has its union, but we are a little selfish or something is wrong, because we hardly know what the other fellow is doing.

One suggestion to the paper—not as a kick, but for information: would like to hear more of the prices charged for work. Our own prices in this section are as follows:

- Shoeing, plain flat—no calks, as we don't want them down here...90 cents a pair
- Shrinking Tires, 2" and less....75 cents
- 2½" and up to 4".....\$1.00
- One shaft—buggy or one-horse-wagon \$2.00
- full set .....\$5.00
- Oak Two-Horse Wagon Tongue, 2x4 and up .....\$4.00
- Oak Coupling, 2x4 and up \$1.50 to \$2.50 and up.

We have a motor and grinding machine and get 25 cents for grinding an ordinary cast or chilled point and vary in proportion to size. For welding and dressing shafts we get \$1.00 per inch; 50 cents for shaft irons; and \$8.00 for set of 3x9 cast wagon skeins and boxes, put in.

We have a lovely climate here, seldom have frost and rarely hotter than 98 in summer, with green vegetables all winter. Saw milling is a big industry here now and we have lots of fine yellow pine timber and getting good prices. Wishing you success.

CAIN BROS., by M. C. Cain, Florida.

**Describes a Handy Tire Bender**—Having been a reader of your valuable paper for several years, and having profited by several things I learned in its columns, I will send in for the benefit of my fellow craftsmen a drawing of a handy and con-

venient tire binder that any blacksmith can make.

It consists of a wheel about 3 ft. high built by using 2" x 4" spokes with 2" x 4" rim. And 1" x 6" cut to the circle of rim to form a 1-inch flange on each side. Centre of wheel has a 12-inch circle of 5/16" iron that is firmly clamped on each side; with 3/4-inch hole in centre for axle. Handles are formed by using 3/4 round iron put through the rim at each spoke and extending out 6 inches on each side. The wheel is then mounted on a stand so the wheel can be turned, and a clamp is made of 1/2-inch round iron to fasten one end of iron to be bent to the wheel. The stand has an idle roller to guide the iron and reduce friction as the wheel turns. It will give an even bend, satisfactory for the shaping of any size tire up to ½" x 4."

ALEX SAPP, Florida.

**A Few Queries on Forging from a New Member of the Craft**—As I am somewhat of a new man at the anvil, I would like to ask you a few questions to be answered through your valuable paper.

I have had real good luck in welding nearly everything but spring steel. If I bring it to a welding heat it falls to pieces, and if I try to weld at less heat, it doesn't stick. Please tell me what is the matter and if there might be any good welding compound that would be of especial help in this case. There are so many kinds advertised that I am at a loss to know just what to choose as they all claim to be the best. For most jobs I heat to a cherry red, but this does not seem to work on spring steel. But I blame myself for this trouble.

I have good luck soldering everything except copper and it seems that I cannot do anything with it. Please tell me also what is the matter here. I use muriatic acid. Is there anything better?

I am thinking of building a lathe to turn wood pulleys ranging from four inches in diameter up to 14 inches. Would a speed of 500 R.P.M. be sufficient to handle this work in a satisfactory manner? And at about what angle should the chisel be held to cut most efficiently?

Can you also tell me of any safe way to proceed with welding small castings in a forge fire? I had a job of welding one two inches square but turned it down.

I like your paper fine, but have not taken it long enough yet to have a collection of back numbers. I am a great believer in trade journals. I am a thresherman by trade and know that I have received unquestionably a vast amount of information through the trade journal columns. Why shouldn't they be a great thing as they often give a person a chance to commence where the other fellow left off, after a life time of experience?

Wm. Fix, Illinois.

**In Reply**—By welding spring steel we presume you refer to the average run of jobs that you run into frequently—namely, the actual welding of automobile, wagon and buggy springs, etc., which present rather a tough problem to even the experienced workman at the forge.

Spring steel usually contains a fairly high percentage of carbon and would therefore be difficult to work at the best. It can be done however, but the greatest care possible must be used in order to get a satisfactory weld. Often times a weld may be made which appears all right, but

when the spring is put into use again it does not stand up under the strain.

You speak of being unable to weld at either a high heat or a low one. That is quite natural: if the temperature is too high—that is, when the sparks fly, it will fall to pieces from even a light blow of the hammer. On the other hand, if not heated enough, it is impossible to make it weld. A happy medium must be found, and that can only be learned by experiment. Usually the right heat is a bright yellow.

It is difficult to hold just the right heat while making the weld in such thin metal as is usually found in spring steel. A good way to get around this, whenever it can be done, is to make a split weld. That is, split both broken ends for a half inch or so and bring snugly together. Mr. Steelman described this stunt in his article in this issue. See Fig. 3. It is an easy matter, after securing this way, to heat up the metal and weld, using a flux compounded of one part Sal Ammoniac and four parts Borax.

Concerning welding compounds, there are many on the market and many others easily made up in the shop by the blacksmith himself. Several good formulas appear elsewhere in this department for this month.

Soldering copper does not present a great deal of difficulty if one knows how to go about it. Perhaps you have used the wrong solder. This would easily cause trouble; in fact, unless you employed the right solder it would be almost impossible to do the work. Try making up your own, using the following proportions and metals:

- |              |          |
|--------------|----------|
| Copper ..... | 5 parts  |
| Lead .....   | 1 part   |
| or           |          |
| Copper ..... | 80 parts |
| Lead .....   | 15 parts |
| Tin .....    | 5 parts  |

As to the proper flux, muriatic acid, if pure, is good. But you probably get only the average commercial grade, which serves admirably for ordinary purposes, but not for copper. Here, the chemically pure product is necessary. You can make up a good fluid as follows: dissolve granulated zinc in muriatic acid—letting the acid take up as much of the zinc as it will. The zinc may be easily granulated by melting in a ladle and pouring slowly into a barrel of water. A brush or swab should be used to spread the fluid over the work. Keep the point of your soldering iron well cleaned. A good way to do this is to wipe with a cloth or piece of waste dampened in the fluid.

Small castings such as you describe cannot be welded successfully, but must be brazed. This can be done by tying the parts together loosely with wire and heating up in the forge. Then drop borax down between the two parts and immediately after it has melted and run down, sprinkle in bronze spelter. This makes a good, substantial joint.

In turning out pulleys on a lathe, naturally a higher speed is required for smaller work. Variable speed should therefore be provided. We would suggest that you write the manufacturers of wood-working lathes and get your ideas from their catalogues. As to the proper speed, you should provide at least 1,000 R.P.M. for small work and as low as from 500 to 800 for the larger pieces.

S. S., New York.

**Some Questions on Plow Work**—I am just starting at blacksmithing and have lots to learn yet. I am green at it and would like to hear from you about the following: what should I use to put on plow lays to make them sure? What is best to put in when land slide opens up? How is it best to weld up again? What must I use to make lays scour? Where can I get a frame to put lay in when I put it in water?

Wm. OLSEN, South Dakota.

**In Reply**—We trust the following general information concerning plow work will cover the questions which seem to puzzle you:

Plow laying is a piece of work that requires no little amount of skill, and the percentage of blacksmiths who make a good fitting and a good looking share is small. To put on a short bar or slip-share, first strip the old plow of the old share, then forge your bar to fit properly so it will line up with the land side, but do not drill your holes yet. Take a small clamp and place on plow, so that you can fit

use new bolts; never use old ones. Now square your holes, and you will never have any trouble taking them out when you want to sharpen. In the long bar plows you should drill your holes before welding. There is more work on them than on the short bar, but as a general rule not so hard to fit. If they are worn badly, you will have to make a whole new bar. You can weld on the front, and by laying a piece of steel on the head they will work all right.

When the bar is fitted bolt on temporarily so as to fit your share to it when welding. Start at point and weld up, then as you go back down you finish by shaping your point. The welding is an important part, and good fitting makes the welding an easy task. There are few better ways to turn out a good looking piece of work than by using tongs and drilling holes as described when welding slip shares.

You can secure a useful device to hold shares while working from the Burgess Mfg. Co., located at Greenwood, Missouri. They make a special holder which prevents springing of the share and greatly facilitates the work of the plowsmith. We would suggest that you write them direct for full information and their advice on plow work.

Welding Compounds without number have appeared in past issues of the American Blacksmith. The following are reprints of a few—all good ones:

Borax, or some compound of which borax is the main element, makes the best welding compound for steel. There are several ways to prepare it and you might try one of the following:

Melt a quantity of borax in a small crucible. As soon as it has the appearance of a dark syrup run it out on a dry, clean floor to cool. When cool, powder and mix with filings or fine borings or wrought iron or steel; also add a small portion of carbonate of iron.

When using this compound put it on the work when well red—in fact the steel should be just on the verge of a good fuse when it is applied. You will find this flux quite cheap and very effective.

Another very good compound is made up by mixing:

One pound of pulverized borax, with two ounces of carbonate of iron and ½ ounce nitrate of potash.

One that is said to be especially fine for welding up plow shares or laying plow shares, can be made by adding to every pound of pulverized borax, four ounces of dry venetian red paint (or any colored dry mineral paint). You can burn the edge of the lap and put some of this on it and weld it up making a good, solid edge.

Of course it goes without saying that your fire must be clean and as free from sulphur as possible. Borax always contains a quantity of sulphur, but the process of melting it and boiling it dry described above greatly improves it. If you care to go to a little more expense, which might more than pay for itself, here's a compound which has been used for years by one of the most successful steel workers in the country:

- |                                |       |
|--------------------------------|-------|
| Pulverized borax .....         | 1 lb. |
| Carbonate of iron .....        | 2 oz. |
| Black oxide of manganese ..... | 3 oz. |

Mix thoroughly, and use as you would the simple borax compound, only heat the steel a little hotter.

S. S., New York.

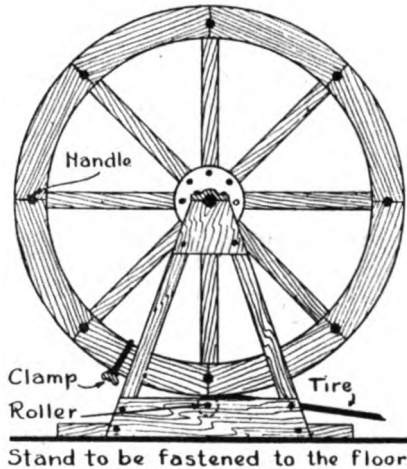

MR. SAPP'S TIRE BENDER

your share. With regard to the share itself, as nearly all blacksmiths use the shapes as they are ground, you may have to make some changes is almost all of them: some by upsetting and some by setting down.

After you have fitted your share properly, remove your clamps. Take the bar and share without drilling any holes and weld. Place the bar and the share in the tongs, heat with point up, then bend over and take a good heat. Another heat will bring you up to your tongs. Now remove your tongs and take the final top heat. This is the time when you want to do your fitting. While it is good and hot, hold share on point of share, which will upset the bar and make a good joint. To clean your work, it is good to hot rasp it. Now heat again, and shape it as you work back to the point. Be sure in so doing that you keep your bar straight. Now finish by working your point in shape, making a diamond point, which makes a nicer job.

Some smiths do not like drilling the holes, as they cannot drill from the inside. But it can be done nicely by carefully marking the outside very closely and fitting in a wedge shaped block of wood. Now countersink the holes so that a new plow bolt head will come down even with the share. Always, in making new shares,



## The Automobile Repairman

### The Care of Tires\*—5

Helpful Hints for the Automobile Repairman

Fabric, like steel or any other article, has its limit of strength. Taxed beyond that point it will break. A rupture may be caused from a cut or bruise and usually, although not always, the fabric splits

sufficiently pointed to strain and cause breaks in the fabric of the tires. The original damage to the fabric may be slight but continual strain will cause the rupture to become larger and eventually pinch the inner tube—sometimes both case and tube may blow out.

It may be interesting to know that certain specifications and rigid tests are required of fabric for quality tires. A square inch must contain a specified number of threads in the warp (lengthwise); also in the filler (crosswise). Each thread must be twisted to specification and contain a certain number of strands. The twist and length of the cotton staple, in these strands, is likewise considered.

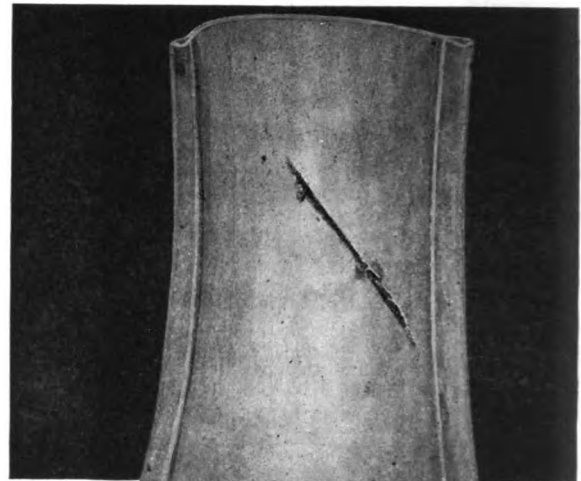

A fabric rupture which may have been started long before it was noticed, caused by the breaking of a few threads of fabric resulting from a cut, severe bump, or bruise to the case. Internal pressure and weight on tire caused rupture to continue to break along bias of fabric

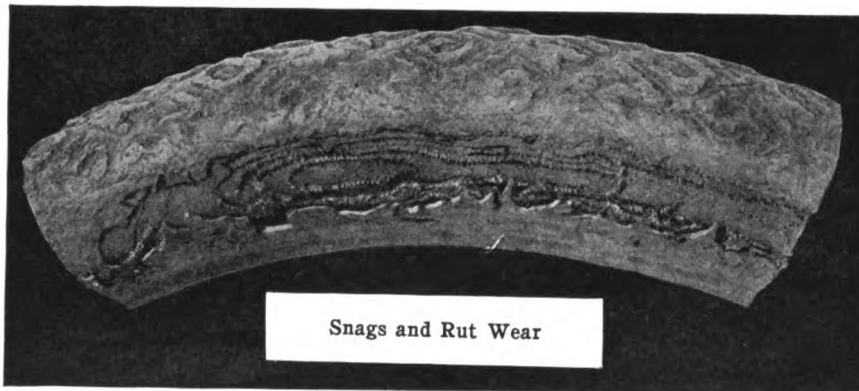

Snags and Rut Wear

Side wall rubber and several plies of fabric worn away by rut wear, grinding against curbs, etc.

with the bias or direction of the threads. A sharp stone or other cutting object will sometimes leave a mark in the rubber cover but frequently a severe shock from blunt objects will develop a rupture and *not* leave any mark in the soft yielding rubber. This injury may occur from driving with considerable speed over stones in the roadway, dropping into deep holes in the pavement and ruts in the road. When turning around in the street, some drivers carelessly back rear tires against curb stones. It is a common practice of some car owners to run front wheels against curb stones especially if the brakes are not in good order. The edge of curb stone is not always sharp but, when driven against same with much force, it is

A square inch of high quality tire building fabric has an approximate

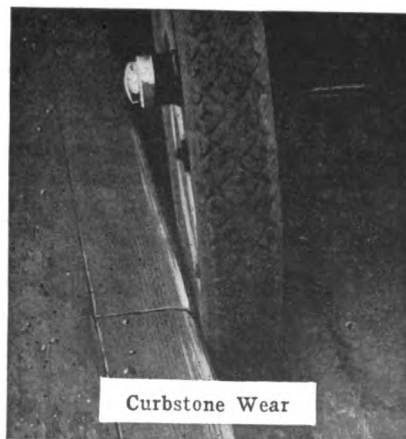

Curbstone Wear

Manner in which side walls are ground off by rubbing against curbstone

breaking strength of from 275 to 300 pounds. A roll of fabric is *rejected* unless it meets these inspections and tests and then is found to be uniform in weave, free from grease and other foreign matter.

With these things in mind, it will be easier to understand that a break through several plies of fabric, as shown by illustrations, cannot very well be attributed to weakness in construction. Breaks of this nature invariably result from a cut, bruise or similar injury causing the *initial* damage to the tire.

There may be times when bad roads cannot be avoided, but side wall injury to the tires under such circumstances should not, in fairness



Rut Wear

Abrasion by dirt and stones in making roadway

\*Courtesy Firestone Tire & Rubber Co.



be considered as an indication of fault in the quality or construction. The sides of a tire are not intended to withstand such abrasion and wear as is to be expected from rubbing against curbstones or driving in deep, stiff mud or over rutty, rough or frozen roads.

Wear of this kind usually occurs on one side of the tire—the side from the car. Small tires that find the lowest road level will usually receive the most damage, however, inflation, weight of car, camber of front wheels, tread widths and other things all have a bearing on the extent of side abrasion.

The side walls of a tire must be flexible in order to properly distribute the strains, give resiliency, minimize heat, prevent sharp bending of fabric, breaking and separation. Therefore, it is desirable that the rubber on the side walls be elastic and not too dense or firm; the same hard, wear-resisting rubber as used on the tread is not suitable for covering the side walls.

It is possible, under very severe conditions, to wear through the side wall rubber in a very short time, but, ordinarily the wear, as shown by illustration, indicates neglect. If it is necessary to drive occasionally over bad roads, reverse the tires; i. e., place the worn side toward the car, vulcanize rubber over the most worn parts to protect the fabric from moisture and disintegration.

Care in observing these simple, but highly important rules, will be rewarded by having tires of long life, few blowouts and general satisfaction.

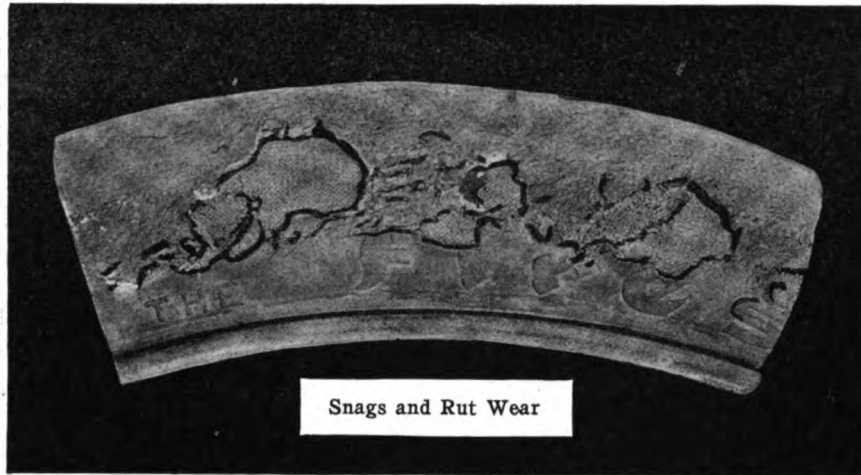

Damage done by driving in rutty, unbroken or frozen roads

### Gas Engine Operation Made Simple—11

The Purchase, Installation, Operation and Troubles of a Gas Engine.

J. L. HOBBS

#### Compression

It will be the aim under this head to tell you just what causes your engine to fail in having proper compression. An engine will fail on power in proportion to the amount of compression that gets away without performing its work in the cylinder. This leak may occur on the compression stroke or it may get away on the power stroke or at both times.

An engine will have perfect compression when the explosion chamber is perfectly air tight. Any leak, be it ever so small, will affect the compression and in turn have its effect

on the power of the engine. There are a number of things which may cause an engine to loose compression; that is, these leaks can take place at various places. We will point out where these leaks usually occur and how to prevent them. A few of the common sources of leaks are as follows: poor lubrication in the cylinder around the rings and piston, a broken ring, a worn ring, a hole or crack in the piston or cylinder wall, a scratch or groove in the cylinder wall, a leak around the spark plug or igniter, a leak around the gasket between the cylinder head and the cylinder, a leak around either valve or the valve cage—if one should be used, a leak around the priming cup, or a leak around the drain cock which is sometimes in the bottom of a cylinder to provide for draining any foreign substance from the cylinder. These will be taken up and discussed in their turn so that you will know just where to look for the leaks and you will also be told in each case how to remedy each leak when found.

We will commence our search for leaks at the end of the cylinder next to the crank shaft. If the engine is running, by listening at this end of the cylinder you can sometimes detect a leak, if there should be any surplus oil going into the cylinder and there is a leak around the rings this surplus oil will come out around the rings in the form of a fine spray which is visible to the eye.

If the engine is not in condition to run or will not run on account of lack of compression, by taking hold of the fly wheel and rolling it back and forth and listening for any hissing sound you are sometimes able to detect the leak in this way. If you suspect a leak around the spark

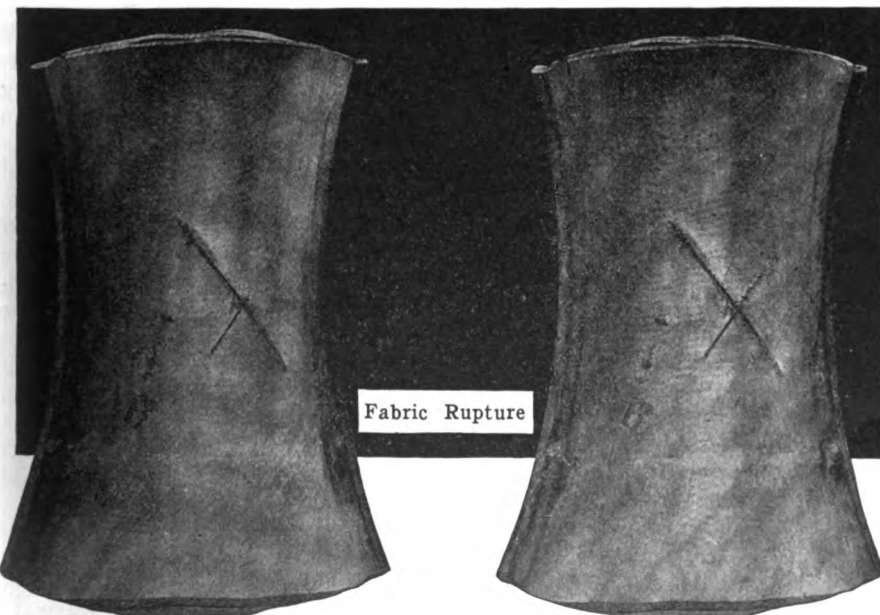

Showing break running with bias of warp and partly with bias of filler threads

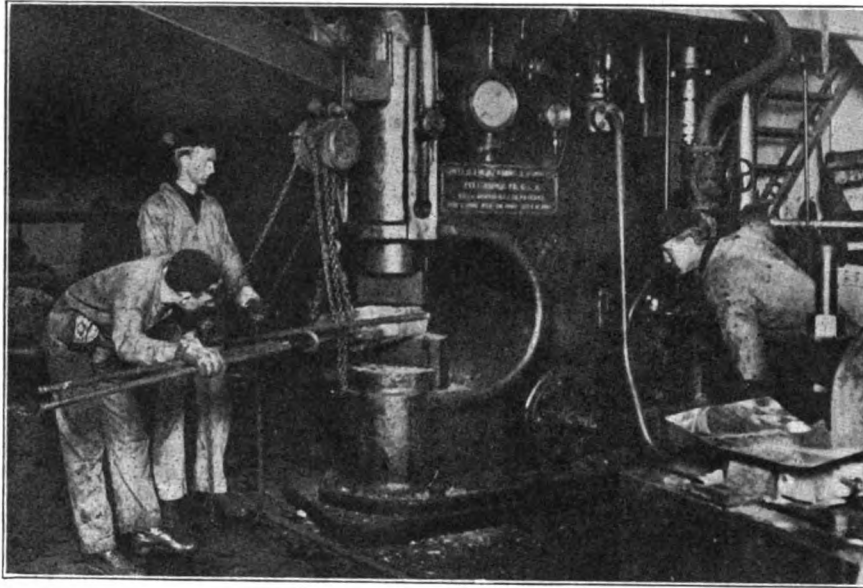

UNCLE SAM'S POWER HAMMERS PLAY A VITAL PART IN HIS SCHEME OF PREPAREDNESS.—BLACKSMITHS WORKING "SOMEWHERE BETWEEN DECKS" ON A MAN-O'-WAR

plug, igniter or any other opening into the cylinder, a drop of oil in the opening will show a bubble when the compression is put on the cylinder. If the bubble does not show there is no leak.

If in doubt about the rings or piston or inside of the cylinder the piston should be removed by disconnecting the connecting rod from the crank, when the piston will move right out towards the crank axle. If you have any doubts about a crack or any other leak in the head of the piston, place it open-end up and pour some gasoline in; watching all the time for leaks around the bottom or solid end. If no gasoline comes through there is no leak.

Be sure to observe whether or not the piston, rings and cylinder wall are all covered with a film of lubricating oil. If they are, the lubricating system is working properly; if not, or if the oil is gummy, it is an indication that the oil is either not going into the cylinder in sufficient quantity, or that the quality of the oil is at fault. In either case the lubricating mechanism should be examined to determine the trouble.

The rings should now come in for a little study. There are two methods of placing rings in the grooves. One is to place them in loose so that they may move at will around the cylinder; the other is to have a small notch or hole in one end of the ring which will fit over a small pin or plug of some kind in the piston to hold the ring in one position all the time. The latter way prevents all the openings in the rings from getting

into line, as these pins are placed at about equal distances around the piston for the purpose of keeping the ends of the rings from all getting on one side of the piston.

Before removing the rings from the piston for the examination of the grooves in which the rings work, move them from side to side to see if any wear is apparent. They should fit snugly, but should move freely. If there is any wear at this point, you must determine whether the wear is on the ring or the groove. If on the ring, a new ring will remedy the matter, but if the groove is worn so that a new ring does not take up the wear, then a new piston is advisable; although the groove may be trued up at a machine shop and a ring made to fit it that will work all right, and is probably cheaper than a new piston. The objection to widening the grooves is that it gets your engine out of standard so that you have to have the rings made instead of being able to buy of the manufacturer. The machine shop rings will cost quite a little more than the factory rings.

Watch out for brown streaks on the rings and also on the inside walls of the cylinder, as these are a sure sign that there is a leakage between the walls of the cylinder and the rings. This leakage may be the fault of the rings or it may be there is a slight variation in the wall of the cylinder. This can be determined by slipping the ring into the cylinder and moving it endwise in the cylinder. A new ring is better for this test than one which has been used.

When this trouble is located it will of course be remedied by supplying the necessary new parts. While it is sometimes cheaper to have a cylinder bored out and new rings fitted, it is always bad practice on account of the fact that some other time it may cause you extra expense when other repairs are needed. For instance, if you would have a new piston and rings made after having the cylinder bored out, when the cylinder fails, you would be compelled to get both the rings and piston new; also, because the piston would be too large for the new cylinder.

A common injury to the inside walls of a cylinder is caused by the piston pin getting loose and working endwise in the piston. The piston pin, being of case-hardened steel to prevent wear, will soon cut grooves in the sides of the cylinder, which will let a lot of compression get away. The only satisfactory remedy for this is to supply a new cylinder and securely fasten the pin so that the injury will not be repeated.

A case comes to mind when an injury, similar to the one above stated, caused an operator a lot of trouble. The cylinder in question was practically a new one and was for that reason not suspected; not even being tested for loss of compression. He thought his trouble was in his carbureter. The engine would misfire under light load and sometimes when running slow with a full load. The real reason for the missing fire was found to be this: that the compression in the cylinder was allowed to leak away until it would not fire on that account. When running rapidly under a full load it would do fairly well. After endless experimenting with different carbureters and almost everything else, an expert was called who detected the loss of compression in the newest cylinder and decided to take it off; which when done, revealed the grooves in its walls. A new cylinder was supplied and the engine ran all right. The owner acknowledged that when he put the cylinder in position that there was no set screw in the piston to fasten the pin and he did not think it of any importance to have it, so did not get a new one. He will fasten the pin next time. Nothing should be too small to claim your attention.

Having thoroughly gone over this end of the cylinder, we will next turn our attention to the explosion chamber at the other end.

(To be Continued.)



# TIMELY TALKS WITH OUR SUBSCRIBERS

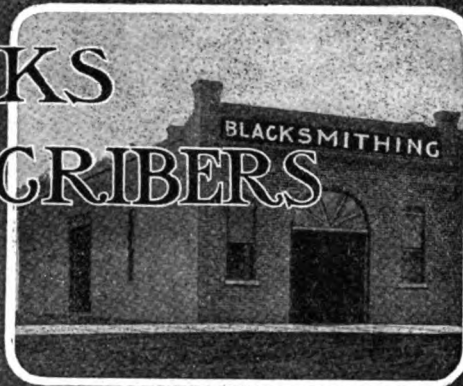

The American Blacksmith is published monthly at The New Sidway Building, Buffalo, N. Y., U. S. A., by The American Blacksmith Company. Incorporated under New York State Laws. Entered, February 12, 1902, as second-class mail matter at Buffalo, N. Y., Act of Congress, March 3, 1879.  
William F. Wendt, President

Albert W. Bayard, Secretary  
Associates: Bert Hillier, A. C. Gough, Harry O. Mitchell, Editor  
Dr. Jack Seiter  
Subscription Price: \$1.00 per year in advance, prepaid to any postoffice in United States or Mexico. To Canada, \$1.25; other countries, 6 shillings. Reduced rates to clubs of five or more on application. See "Honor Roll" page for money-saving, long-time rates. Cable address, "Blacksmith," Buffalo. Lieber's Code used.  
Subscribers should notify us promptly of non-receipt of paper or change of address. In the latter case it is necessary that you give us both the old and the new address.

## CONSERVATION

The watchword of the Nation during the period of the war is "conservation." Conservation means simply this—the saving of energy, time and materials in every possible direction and turning these factors to the best possible use. It involves the elimination of waste of every kind and this implies the stopping of leaks wherever they exist. No matter how small the hole in the dike, it was the little leaks that were dangerous to the safety of Holland; for little leaks grow and there may be many of them—unobserved because of their smallness, but in the aggregate of tremendous importance. The same comparison applies to the present situation. We must stop the leaks; watch out for the little things; conserve our resources to the utmost.

How can the blacksmith do his part in this direction? There seems to be but one answer to this question: apply scientific management to his business. And this means system in his shop: careful, systematic buying, collecting closely and promptly, thus avoiding the accumulation of bad debts, knowing his costs accurately, and employing efficient accounting methods.

You cannot afford to be lax in this direction. With prices for materials and supplies ever mounting higher, carelessness or negligence in this respect may spell disaster. But aside from any personal considerations, there should be a higher motive back of your efforts at conservation—the welfare of the Nation. It is what you do individually that counts. You and the other man and hundreds of other brother craftsmen working together for the same purpose. It is your way of "doing your bit" for Uncle Sam if you are not with the boys fighting at the front.

### Subscription Agents

When a stranger solicits your subscription to THE AMERICAN BLACKSMITH or any other publication, insist upon him showing you absolute proof that he is an agent in good standing and is employed by the publication which he represents. Don't under any circumstances, give the man your money if you are not sure that he really works for the paper he says he does. No matter what the man offers you—no matter what price he makes—no matter what premium he promises to send—Don't Give Him Your Money If You Are Not Sure.

## CONTENTS, SEPTEMBER, 1917.

Rock Drilling Machines at Work in a Quarry—Frontispiece .....	288
Building a Successful Manufacturing Business from a Small Blacksmith Shop .....	289
System in Buying and Selling.....	293
A Few Observations Concerning Side Lines .....	294
An Example of Progressive Smith Shop Advertising .....	294
How a New York State Blacksmith Met the Price Situation .....	295
Half a Century in the Smithing Business and Some Lessons Learned Therein .....	295
The Cost System Used in a Big Pacific Coast Shop.....	296
The Cruise of an Anvil Pounder....	297
When Purchasing Goods It Is Well to Know That Any Strings to Orders for Goods Must be Attached to the Order Itself .....	298
The Smith in the Daily News.....	299
Iron Bruisers' Picnic .....	299
Blacksmith Joins Colors .....	299
Town Wants Blacksmith .....	299
To Shoe 300 Horses .....	299
Blacksmith Preacher .....	299
Hold-up Blacksmith .....	299
Blacksmith Escapes Lynching ....	299
Blacksmith Gives U. S. Four Sons. ....	299
Cutting Prices—Poem .....	300
Heats, Sparks, Welds .....	300
Our Honor Roll—Nebraska Getting Warm! .....	301
The Machine and Tool Smith.....	302
Rock Drills .....	302
Queries, Notes, Answers.....	309
Who Wrote for these Books?.....	309
From a Kansas Subscriber .....	309
Speaking of Vacations.....	309
A Successful Mixed Business in British Columbia .....	309
Two Queries on How to Weld a Cultivator Axle .....	309
Index to Volume 16.....	310

## MAKING A BUSINESS OF BLACKSMITHING

This is our big Business Number of the year. Every page is crammed to overflowing with facts you can use to splendid advantage. There are articles on every phase of *business blacksmithing*—purchasing, selling, advertising, cost finding, accounting, shop equipment, side lines, collecting, etc. Many are written out of the matured experience of a life time and what they say may be taken as authoritative.

By studying these methods you will find practical ways and means of systematizing your business—of applying the principle of conservation directly and effectively. Read them, study them, apply them. And if any question puzzles you or you desire information on any subject pertaining to business methods in the shop, just write in to Subscribers' Service.

Then if you have any ideas of your own, or have put into actual practice in your shop methods that would likely benefit brother craftsmen, send 'em in and thereby "do your bit" in helping along the good work.

### VOLUME SIXTEEN

This issue marks the closing number of Volume 16. It is appropriate that the last number of this volume should be devoted to business methods for the smith shop; for the ways and means for doing business along better lines, as pointed out therein, will prove a valuable guide for our readers during the coming year.

Since September, 1901—sixteen years ago, "our Journal" has stood for clean methods, clean living, and a bigger and better craft. Always it has kept the welfare of the craft in view. And in consequence it has seen the craft of sixteen years ago emerge from its mistaken ideas as to shop equipment and methods of doing business into a condition more in keeping with modern ideas and of vastly greater benefits to our readers.

Great changes have taken place during those years. Changes that have put modern machinery onto the smith-shop floor, changes that have put more money into the smith's pocket and a broader conception of his place and importance to the community. And we're proud to say that "our Journal," with the staunch help of "Our Folks" has taken such an important part in being able to start and promote many of these reforms and changes in the craft.



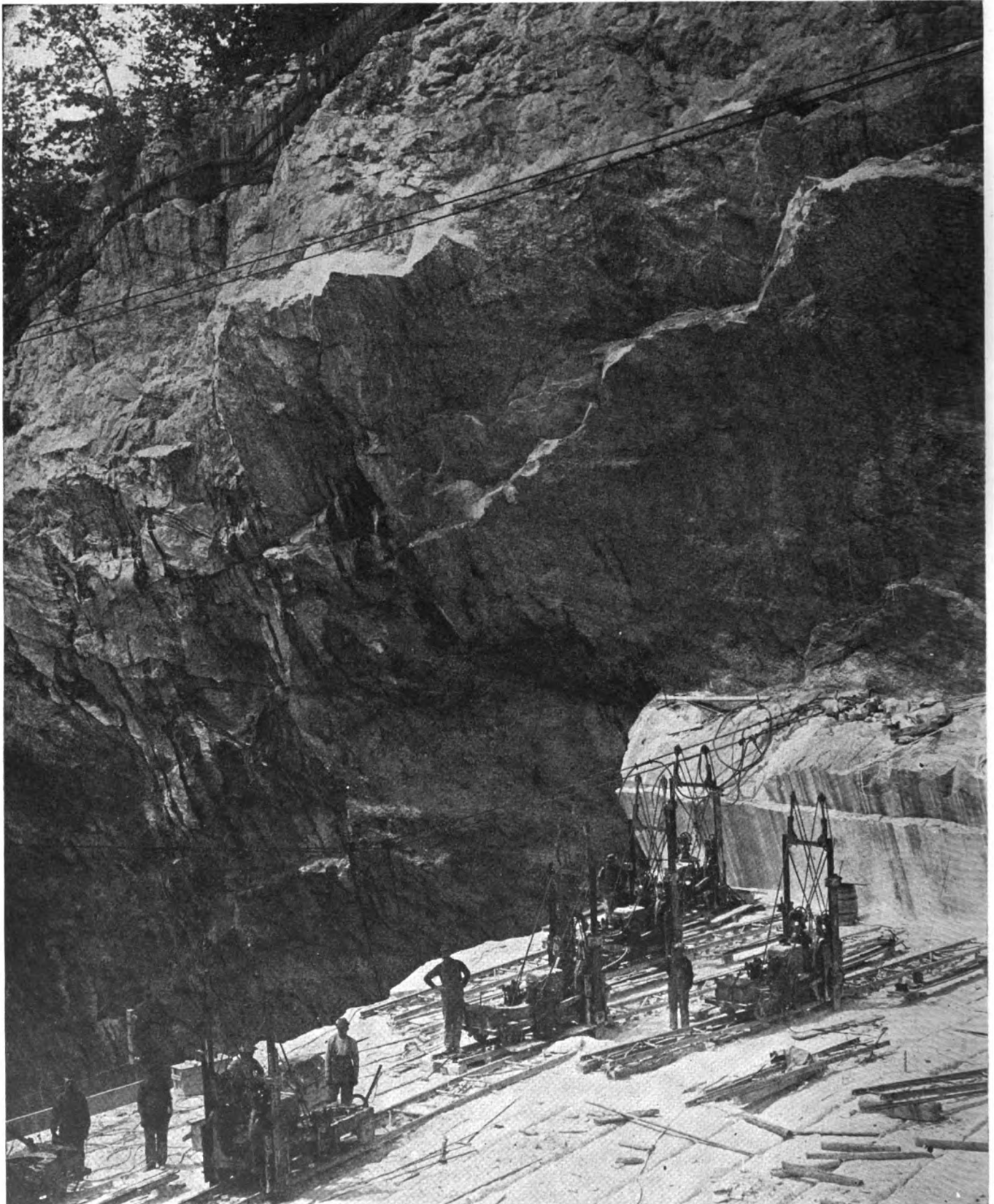

*Photo courtesy the Travelers Insurance Company (From "The Traveler's Standard")*

### ROCK DRILLING MACHINES AT WORK IN A QUARRY

King Solomon called the blacksmith "the peer of all artisans" for the reason that it was his work in shaping the tools that made nearly every other art possible. Today, no less than in Biblical times, the smith's work is a vital factor in the life of our industries. Particularly is this true in rock drilling, which enters into a vast number of human activities. Here we see work going on in a great quarry where the blacksmith's part in shaping and caring for the tools, especially the drills, is a big responsibility. Mr. Steelman describes, in his article on page 302, methods of shaping, grinding and tempering rock drills of all kinds which will prove a valuable guide to every craftsman of the forge who has occasion to care for rock drills.



# BUILDING A SUCCESSFUL MAUFACTURING BUSINESS FROM A SMALL BLACKSMITH SHOP



**"I** S this Mr. Briddell's place?"

"Yes, this is Briddell, the tong-maker."

"Mr. Briddell, my name is Jones. I am a blacksmith and run a blacksmith shop across the bay. I have often heard of your shop, but did not expect to find one of this kind. The front looks like a store with that big transom window all the way across the front."

"Well, the reason for that, Mr. Jones, is that I find I cannot have too much light, and this large window sends the light all over my shop. Then again it helps to make the place more attractive and that's a mighty good thing."

"I notice also, Mr. Briddell, that your shop is ceiled inside."

"Yes, Mr. Jones, I have had several shops, but none were comfortable in winter. But with this one ceiled inside and with metal siding outside, we can do all work in comfort on the coldest days and that means more profit than if the men were forced to sit by the fire to keep their toes warm."

"I notice also, that you have three forges in your shop, and the smokestacks, I think, are the largest I have ever seen on a smith shop."

"Yes, they are extra size. They were originally only eight inches in diameter, but I found they did not draw very well. Since I have put up twelve-inch ones, you will notice they take all the smoke away nicely. The forges are Champions."

By

CHARLES D. BRIDDELL

"I see you have a good deal of machinery in your shop. How do you like it and how does it pay?"

"Very much indeed, and I find it a great advantage. Come back to the rear of the shop with me and I will be only too glad to explain to you what a wonderful help machinery has been to me. You are aware, of course, that my business is mainly manufacturing oyster knives and tongs."

"This first machine is a Fairbanks "size A" Power Hammer and do you know, Mr. Jones, in hammering out the parts for my oyster tongs, I can do from four to five times as much as can be done by hand? You will notice these tong-bars. Well, it takes a man and helper twenty-five minutes to hammer out one set with a hammer and sledge. But with this power hammer I can do the job up right and hammer out six sets in thirty-five minutes. So you can judge for yourself which is the easiest and best way. In heating the material to make parts for my tongs, I use this gas furnace. It keeps the steel at a uniform heat and always ready for hammering."



"What is this big machine to the left?"

"That is known as a Power Punch Press."

"What do you use it for?"

"I bought this machine to punch out my oyster knives. As you will notice from the dies on the shelf, I have a different set of dies to cut out each style of knife I make. Do you know, Mr. Jones, this machine is a wonderful help in my other work? Here is a set of shearing-dies. When I put these into the press it is just like fun to cut up any length desired for bars, teeth, shanks, ribs, etc., for my tongs. With this machine I believe I could cut up more iron in a day than a man and helper could do in a month by hand. You will notice also these dies used for punching holes. There are several styles of tongs I make which require forty and fifty holes. With these I can punch 'em just about as fast as a chicken can pick up corn."

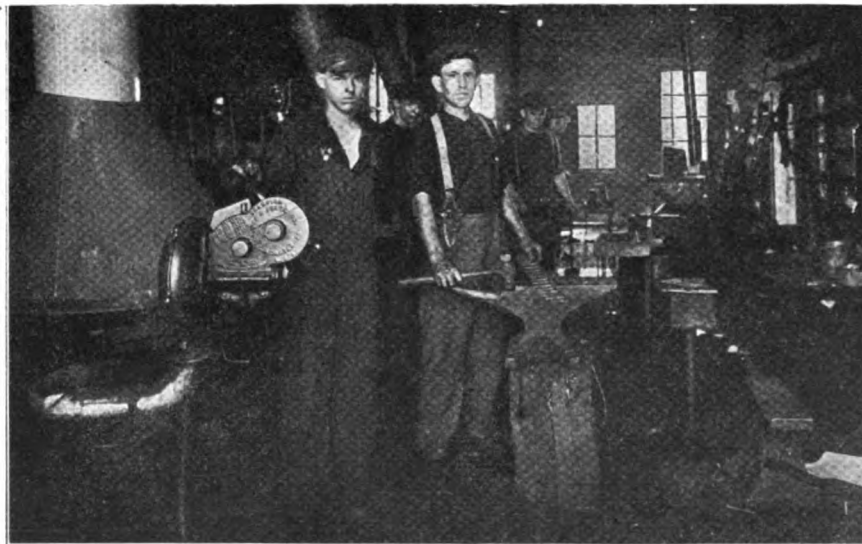

FIRST FLOOR OF MR. BRIDDELL'S PLACE SHOWING SMITH SHOP. PART OF THE MACHINE SHOP IS SEEN IN THE BACKGROUND



"What kind of an engine do you use to run all this machinery?"

"It is a kerosene engine, rigged up out of an old gasoline engine that didn't work well when I first got it.

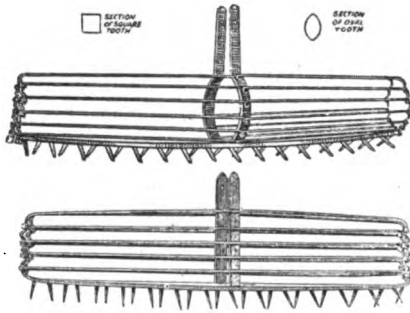

**SAMPLES OF MR. BRIDDELL'S TONG WHICH HE HAS MARKETED WITH GREAT SUCCESS IN SEVENTEEN STATES**

It occurred to me that by running a kerosene feed pipe through the muffler pipe, the fuel would be heated before it entered the carburetor. I believe it runs as well now as a specially constructed oil engine."

"May I ask, how do you finish your knives?"

"Come upstairs and I will show you how it is done."

"These are the machines in which the knives are ground to shape, after which they are tempered in the tempering room at the right."

"How do you temper your knives, Mr. Briddell?"

"That is a part of my business which I hold somewhat confidential. I might say, however, that I have improved the tempering furnaces, in which I treat my knives, in the most uniform and efficient manner possible."

"As I told you before, Mr. Briddell, I have often heard of your shop—it has the reputation hereabouts of being the best equipped shop in the county; and I thank you very much for showing me around. But as I do not make oyster knives or tongs, I do not suppose machinery would be of much help to me in running a general blacksmith shop, building wagons, carts, etc."

"That is where you are mistaken, Mr. Jones. Do you know I was in that very line of business up in Marion several years ago? And had quite a little machinery for that purpose up there?"

"What kind of machinery did you have?"

"Before I describe my equipment in this shop, it might interest you to see a picture of the old shop where I began work and to hear about some

of my early experiences. Sit down, Mr. Jones, and let me tell you about them.

"When I was a boy, going to school, I would often say that I expected to be a blacksmith when I became a man. And every time I would go to town with father, while the team was eating, I would go around to the blacksmith shop and watch the smith work. One day when father came home he brought me an old bellows that had been thrown away by a blacksmith, telling me he had brought me something to play with. I was only twelve years old at this time but I fixed up the old bellows and put them in the old building you see in the picture here. It was used as a smoke house but I managed to rig up a pretty fair shop for a youngster. My first hammer was a hatchet and my anvil a piece of old iron from a steam mill. With this equipment I made a start, without anyone to show me how to be a blacksmith. Soon the neighbors began to bring me some little jobs of work such as making staples, putting in chain links, and other small jobs that I could do. Some of the work was given to me out of pure curiosity just to see what I could do, and some of it just to give them a chance to make fun at my blacksmithing. However, I got so I could do quite a bit of work of this sort and soon thought that I would need more tools. So I decided to make myself a vise. I secured a screw from an old cider

press and with plates of iron fastened to my work-bench managed to rig up a serviceable vise. Next I needed a drill and I went ahead and made one out of cogs from an old binder, fastened them to a frame with one shaft for a crank and another to hold the bit. Just how I was going to make it go was a puzzle. But after awhile I thought of putting the frame in a slide to move up and down by means of a lever. It was some drill! But it did the work all right for a time. Then I got hold of some old thread-cutters, thrown away by a smith. With this equipment I had been running my shop for some time, thinking I was doing fine, until one day I came to town—and as my custom was, visited one of the blacksmith shops to get whatever ideas I could that might be of help to me. One of the smiths in town was very kind to me, showed me a copy of "THE AMERICAN BLACKSMITH," and suggested that I being a youngster, it might be a big help to me in learning the blacksmith business. I immediately subscribed to the paper and it proved to be a welcome visitor each month and was a source of information for me on how to do things and do them right. From time to time I saw pictures and descriptions in this paper how others were doing things in other parts of the country with improved tools and machinery. So I began from that time on to add such as I could to my own shop. I put in



**WHERE THE TONGS AND KNIVES RECEIVE THEIR FINISHING TOUCHES—  
A CORNER OF THE GRINDING AND POLISHING SHOP**

an engine, tire setters, thread cutters, drills, a band saw, and other tools. The band saw I used to fashion cart shafts, wagon felloes and other material for wagons and carts. I also had a twenty-inch pony planer and with this I could dress up more lumber in half a day than a man could do in a week by hand. I had a cold tire setter and set my tires without applying heat."

"I believe, Mr. Jones, if you were to put machinery in your shop you would be surprised at the extra work and the extra profits you would make."

"Now, before you go, let me show you some of the tongs I have made up for shipment."

"Well, well! I never saw so many oyster tongs at one time in all my life. There must be a lot of oyster fishermen around this town."

"No, Mr. Jones. The fact is, there are only a few in this section and they use a very small percentage of all I make up. You see I ship my tongs to different parts of the country—as far north as Connecticut and as far south as Florida. In fact, my business today extends through seventeen different states."

"Whew! How in the world do you get orders from all over?"

"It's like this, Mr. Jones: If one wants to do more than a purely local business, he must use special means or advertising and other methods to get the business. In fact, the same rule applies in a smaller degree to developing a successful local blacksmithing business."

"Would you be so kind, Mr. Bridgell, as to tell me something about your business-getting methods? I think it will help me greatly."

"Certainly, Mr. Jones: I should be very glad to. Perhaps the best way to go about this would be to relate what has actually happened during the years I have been building up my present business and let you draw your own conclusions as we go along."

"As I said before, I began blacksmithing on a very small scale when about fifteen years of age and as business gradually picked up I became quite satisfied with my outlook for trade. But one day I went to the postoffice, about a mile from where I lived, and from there saw a new building going up. On inquiring, I learned that a Mr. H, who was a first-class carpenter and mechanic, was having it built for a wheelwright and blacksmith shop. And the said Mr. H. was going to hire a

certain Mr. S., a noted smith, to do the smith work; while Mr. H. himself intended to do the wheelwrighting. You can guess how I felt then about my future trade. Well I just thought the end had come to my blacksmith business and I went right

will want: a new drag or so will sell, and a few extra sets of double and single trees, some extra chains, etc.'

"Well, the result was that I got all the work I could do and had to hire a helper before long. In less than eighteen months I bought out Mr. H. and he quit the business."

"You may draw the following conclusions from this incident: good work and fair treatment make of your customers regular walking and talking advertisements. And it seems that people would lots rather help a live, wide-awake, ever-busy, hustling, good-humored smith or dealer than the goods-box faker, checker-player or paper-reader who never appreciates a job when he gets one. These hints speak for themselves and should be as helpful for the young beginner, who wants to get his share of the trade and is satisfied with his share, as for you who have already been established in business for some time."

"At about this time, when I was eighteen, I had a new shop. This was a two story affair, size 25 x 40 feet, and was equipped with two forges, hot and cold tire setter, wheelwright and carpenter tools, and a paint shop above. I employed from three to four men besides myself and now started in building new carts and wagons, horseshoeing, carriage painting, etc. With this equipment I soon thought it about time to branch out still more and decided I should be getting trade from other parts of the county, and if possible from adjoining counties."

"My first step in this direction was to put an ad in the county paper. Then, when our fair came off, I decided it would be good advertising to have a nice wagon and cart to put on exhibition. This I did, and I not only won first premium for my exhibit, but sold then and there eleven new wagons and several new carts."

"I also distributed a lot of circulars and secured the names of a number of farmers who seemed interested when looking over my exhibit."

"So from this experience you may draw these conclusions: it pays to let your prospective trade know you are prepared to meet their needs and that your work is the best. My name was painted on every one of the wagons sold at the fair and this proved to be excellent advertising for me as these wagons went to all parts of the county and adjoining counties."

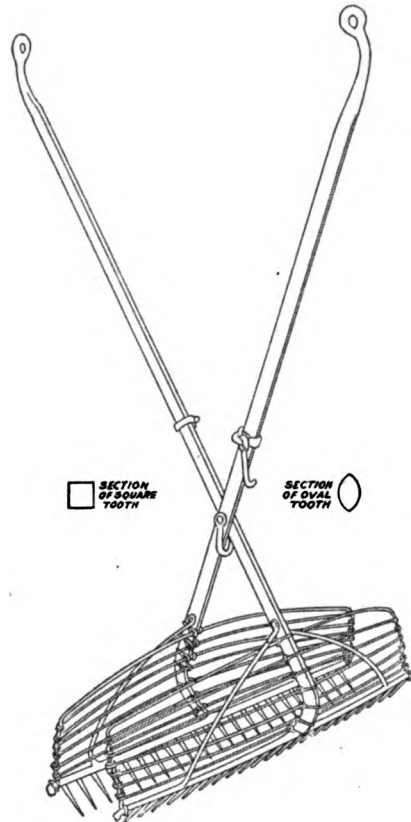

**A PAIR OF TONGS FOR WHICH THE AVERAGE SMITH WOULD HAVE LITTLE USE, BUT UPON WHICH MR. BRIDDELL BUILT A LARGE AND GROWING BUSINESS**

home and told father and mother all about it, and like the kid I was, had a good cry over it and was ready to stop.

"But here was where I first realized the need of advertising. Father said, 'Charley, look here. Don't you get scared until you are hurt, and 'don't cross a bridge until you come to it.' Just go right on working until the last job you have in the shop is done, and take all the pains you can to turn out every job to please, even though you don't make much. And don't attempt to run down Mr. H. or Mr. S's. work, but just tell all who give you work that you appreciate their trade and to tell their friends that you will do their work and guarantee to please them. Then another thing, always be talking about being busy. And should you get out of jobs, just go on making up some new work that the farmers



"Up to this time I was doing business back in the country about five miles from the railroad. Hence my next step was to move into the nearest town, which was Marion, in order to save hauling of material and other expenses incidental to living a long way from the railroad.

"As this was also a much better location from the standpoint of get-

turn out and pretty soon had more business than we could handle. Thus, you may conclude that if one wants to get business on a large scale in a short time, he must go after it.

"During this time, I had been making oyster tongs as a side-line, selling to the oystermen near home and a few at Crisfield, Maryland, a nearby town. The oyster packers frequently told me that if I could make a good oyster knife I could sell all I could make. So considering all these facts I thought it about time to add some machinery and take advantage of this extra business.

"I therefore purchased an engine, band saw, planer, power drill, grinding and polishing machines, made a tempering furnace myself, and started in earnest to make oyster knives. But I quickly found that the home demand was too small to make this business pay, so I thought it would be well to put some sort of an advertising plan into operation to get business throughout the state and also in surrounding states.

"I secured an old Mercantile Agency book and got the names of several hundred oyster packers throughout the country. Next I had some circulars printed and sent them out to my list of names. And do you know, Mr. Jones, I didn't get but two orders from the whole lot—and they were conditional. But I found out the reason good and quick. It was simply this: in having the circulars printed, I failed to show cuts of the knives and I mailed them out in one-cent envelopes. I figured out that most of them accordingly found their way into the waste basket and I was out a lot for nothing. However, I was not quite ready to welcome defeat, so I tried sending out advertising matter in two-cent envelopes, and did a bit better this time. But still I was not satisfied with results. Other schemes were tried with some little success, but not what I wanted until I finally hit on the following scheme: I looked up the places in each state where oyster packing is carried on and then I selected the names of three or four firms from my Commercial Agency book. I wrote every one a personal letter (not a form one), telling them I was anxious to get a good live agent in their town to handle my oyster knives and tongs and asked them to refer me to a good party. I enclosed a stamped envelope for reply and also included some form of advertising matter to

catch their eye. And the result was that usually one out of the three or four addressed to each town would reply and either want to know more about my proposition or would recommend to me some reliable party to act as my agent.

"Then after I finally secured a few agents, I had to help them introduce my goods. So I got up some posters and circulars for them to tack up in conspicuous places or hand out to their trade.

"I often go a step further to help my agents. I look up the names of oyster openers and tongers in the vicinity of their place of business and mail them a circular letter telling them of the high grade of my goods and where they may buy them of Mr. So and So, and that they are guaranteed by him, etc.

"This scheme may seem to you to be going to too much trouble and expense, but I find it pays well after I have figured out a good profit on my goods."

"Would you be kind enough, Mr. Briddell, to show me a sample of the letters you send out to your agents?"

"Certainly, Mr. Jones, here is one."

"You will note that I have emphasized the following five points in this letter:

- 1—I want an agent in your town.
- 2—My prices are right and will show you a good profit.
- 3—My goods are of high quality and only need introducing.
- 4—I will help you introduce them.
- 5—I make it easy for him to help me get an agent in his place if he does not accept.

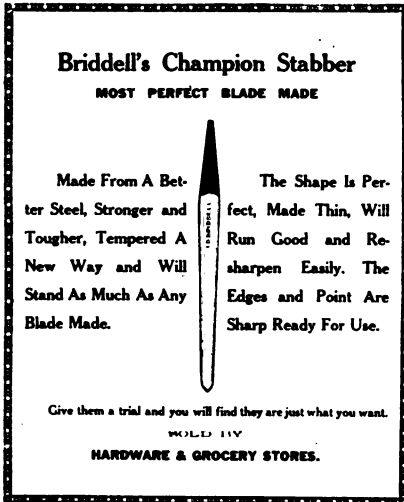

TO ENCOURAGE BUSINESS WITH DEALERS, MR. BRIDDELL SENDS OUT POSTERS LIKE THIS. THIS MEASURES 12 x 10 INCHES

ting business, I built a new shop, 50 x 75 feet, and employed from five to eight men. Now I felt more than ever that advertising was needed to keep things moving. So I put a big ad in the paper showing a picture of my cold tire setter (the only one in the county) and calling attention to my superior equipment and the high class of efficient help I employed; also inviting folks to come in and take a look at my place when they came to town.

"I then had a large stencil made and stencilled my name on a lot of sign boards and had them put up at the cross roads in all different parts of the county. Then when fair time came again I secured a tent and placed on exhibition several different styles of wagons and carts, a sleigh and a hand-buggy of particularly high class workmanship and design, and later on went across to our adjoining state, Virginia, with a similar exhibit. I succeeded, as a result of these exhibits, in selling every cart and wagon I had on hand and started up a trade throughout not only surrounding counties, but adjoining states as well. The result was that in a short time I was selling and shipping all we could

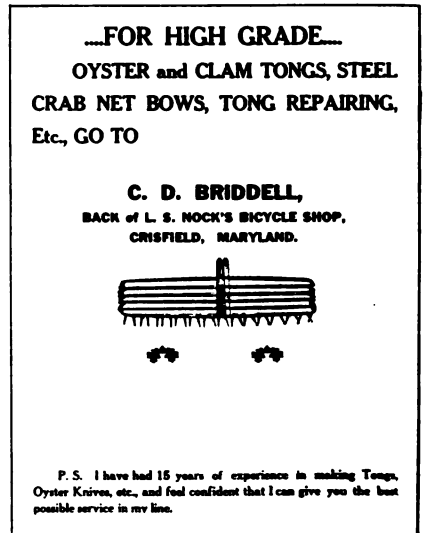

A POSTER USED 'ROUND TOWN WHEN MR BRIDDELL FIRST CAME TO CRISFIELD, MD.



CRISFIELD, MD., September 10, 1917

Mr. John Smith,  
Crystal Beach, Md.

Dear Sir:-

I want an agent in your town to handle my goods, and your name has been given to me as the right man. The inclosed circular will give you an idea of my line. The prices are right to the trade and show a nice profit to the dealer. If you are interested I will be glad to send you wholesale prices and further information.

May I add in conclusion that my goods are of superior quality, they sell themselves, and only need introducing. I will help you introduce them if we get together.

Thanking you in advance for a prompt reply,

I am,

Very truly yours,

*Chas. D. Briddell*

A LETTER SENT OUT TO DEALERS BY MR. BRIDDELL

"I find, Mr. Jones, that this form works very well, indeed. It is short, tells my story in a few words and is written in a convincing, man-to-man fashion just as though I was on the spot talking to him.

"If the answer to a letter is unfavorable, I then send dealers' prices and more information about the quality of my goods and go into detail as to how I will help him introduce my line. Furthermore, I often enclose a testimonial from some well-known dealer on the merits of my goods.

"By following these methods, Mr. Jones, I have secured a volume of business that keeps my shop going all year round and has made it necessary for me to discontinue making carts, wagons, and repairing for some years back. I found it necessary for me to move down to Crisfield in order to be right in the center of the oyster packing business and that's how I happened to build the shop I am in now.

"I hope, Mr. Jones, that this rather lengthy account of my methods and the history of my business may be of some help to you."

"Rest assured, Mr. Briddell, it surely will. I believe I have learned more about how to develop a business, in my brief visit with you this morning, than if I had gone to school for half a dozen more years. Thank you very kindly, Mr. Briddell, for your confidence. I shall value your kindness very highly in the future. Come over to my own shop about a year from today and I think I will be able to show you results from your suggestions."

"I most certainly will, Mr. Jones. I am glad my experience could serve as a worthy example for you to follow. My methods are simply those followed in any successful business and there's absolutely no reason why blacksmithing shouldn't be just as much of a business as keeping store or manufacturing."

System in Buying and Selling

WILL BISHOP

Time was when blacksmithing was hardly considered a business; it was merely a trade which required husky muscles and a willingness to use them. There is an old saying, which originated long before the village smithy stood under the spreading chestnut tree, that "Blacksmiths must needs be wide between the shoulders and narrow between the eyes." It may have been true once—we doubt it—but right here and now we rear up on our hind legs to remark that any plug who thinks our eyes are too close to our noses will keep his own eyes from a sudden blackening by keeping his opinion under his hat. We may be wide of shoulder; but we are also as wide of brow as any other class of men. Our smithies are no longer Chestnut Tree Institutions, but places of business. Our business is one that is a most important cog in the machinery of progress, one that is directed by brains and energy, dignified by honest sweat.

In any business, the first principle of success is *system*. An intelligent method, if you will, of conducting your own particular business; of organizing all forces at your command into a smooth-running machine which grinds out profits. In a way, the blacksmith who conducts his own shop is a merchant. He is the middleman between wholesaler and consumer; and as such, buys the material with which he conducts his business from his jobber, and, plus his labor, sells it to his patrons. It follows naturally that his buying must be done prudently if he is to successfully steer his business canoe down the rapids of keen competition and high cost of doing business. It is to this buying and selling end of the smithing business that I aim to confine my remarks in this article.

Keep yourself in a position to buy as close as possible by discounting your bills. Your jobber realizes that men who discount their bills are the very blood in the arteries of his business, and it is natural and inevitable that he treats them as such by holding out every legitimate inducement to keep them satisfied customers. The smith who discounts his bills is given the advantage of buying at rock-bottom prices, is notified, when it is possible, in advance of any raise in price of stock of any kind, so that he may be able to take advantage of



it; and if a jobber has an overstock of anything on hand to sell at a reduction, it is this same smith who is given first whack at getting in on it.

At the collection end of your business is the place to prepare yourself

that is used every day; but don't let a lot of seldom-used stock accumulate to lie around and rust, or be eaten by worms. Rust and worms make a regular diet of profit, and idle stock is idle dollars. It is better to buy just what you can use every month, as near as possible. This way you get a quick turn-over on your money, besides being able to discount your bills. Of course, it will be hard on the rust and worms, having to move out; but they will turn their appetites onto farm machinery, wagons, and so forth, and do you a good turn by sending a lot of work to your shop. Buy close. Insist on bottom prices. Your drummer knows there are two or three other gentlemen with bay-window fronts, a price-list in one hand and an order-book in the other, who are trying to beat him to your patronage, so it's up to you to see that he don't forget it.

Now, a word along the selling line. In the first place, when you make a charge for a piece of work, don't guess at what it cost you to produce it—*know* the cost. Keep all invoices on stock purchased on file, and when in doubt about what your stock is worth, refer to the invoice. Weigh every ounce of iron or steel that you send out, and sell it by the pound the same as you bought it, with a good profit added. Fix a price per hour for your labor. Find the cost of your overhead expense per day and add to it enough to cover wear and upkeep on machinery and tools, and interest on total money invested in your business. I'll give an example of the system I have used successfully. We'll take a smithing business where the total investment is, say, \$2,000. The interest on \$2,000 at 8% is approximately fifty cents per day, and in a working day of ten hours we'll call it five cents an hour. It isn't quite that much, but in the column we are going to establish for reference when charging for our work, we'll set interest down at five cents per hour. Other overhead costs will follow in the table below:

Interest, per day . . . . .	.50c.	Per hr. . . . .	5c
Rent, " " " " " " " "	.50c.	" " " " " " " "	5c
Power, " " " " " " " "	\$1.00	" " " " " " " "	10c
Upkeep, " " " " " " " "	1.00	" " " " " " " "	10c
Labor, " " " " " " " "		" " " " " " " "	75c

The above charge table is figured on the basis of the smith doing his own work. If he hires all his labor, managing the business himself, he should enter in the "per hour column" the amount he considers his salary is worth per hour. To illustrate the system, we'll say that we

have a job in which we use ten pounds of iron which costs us six cents a pound, but for which we'll charge ten cents a pound. It takes us three hours to do the job, so we'll charge for material, labor, and overhead as follows below, using our overhead expense table for computing overhead cost on the job.

To ten pounds iron . . . . .	\$1.00
To labor (3 hours) . . . . .	2.25
Overhead . . . . .	.90
	<hr/>
	\$4.15

We arrived at a more or less accurate knowledge of our pro-rata of overhead on this job by figuring from our table as follows: Interest at five cents per hour for three hours, 15 cts. Rent, ditto, which is 30 cts. and power and upkeep 30 cts each, which, added to interest and rent is the 90 cts we charged this job for overhead. The price we demand for this job is thus \$4.15; and, instead of squinting at it and scratching our heads when the customer comes for it, and finally guessing it ought to be worth about \$2.50, we get what it is worth and make a reasonable profit.

In all other work, no matter what class of stock is used, if this system is followed I am confident it will be found to be very good. I don't claim it is perfect, or even as good as some that other brothers may use; but it sure is better than guessing and easy to understand and put into practice.

### A Few Observations Concerning Side Lines

WILLIAM K. BELL

A side line is chiefly of value in utilizing those odds and ends of time to be found in nearly every shop and which would otherwise be wasted in idle gossip or in keeping the seat of a grimy morris-chair warm.

The work of the average smith of today has gotten to where it is pretty much all "side lines." To a knowledge of blacksmithing and horse-shoeing proper, he is expected to add carriage painting, vehicle woodworking, tinsmithing, gunsmithing, etc., together with the ability to overhaul and repair anything and everything that can be conveyed to his shop. The result is that he comes into competition with nearly every other artisan in the community.

To the man who is desirous of taking on a side line, a thorough knowledge of some line pertaining directly to the blacksmith trade is a most promising one for him and he has quite a long list to choose from. Among these might be mentioned

### R. E. WORTHINGTON

JOHNSONVILLE, N. Y.  
R. F. D. No. 2

Horse Shoeing—General Repairing—Gasoline

Dear Sir:

Three generations of a Blacksmithing and Horseshoeing family have been continuously doing business at a well-known corner in your community.

For seventy-five years they have given full measure of value and service in every way, and herein solicit your business.

Now is the season your sleighs should be repaired and shod. Don't put them away for the Summer in bad shape and then forget their weak spots. If repaired now they will stay in good useable condition and be ready for the first snow in the Fall.

Wagons can now best be spared for overhauling before the marketing and harvest time come. You cannot afford to have them out of commission in the busy period.

Your patronage is respectfully solicited in all of our branches of work, with the assurance of personal supervision of every detail.

My prices are the same as standard recognized smiths charge in this vicinity, and are lower than those charged in the large towns or cities.

Estimates cheerfully given.

Call, write or telephone.

R. E. WORTHINGTON.

Johnsonville, N. Y.  
R. F. D. No. 2

### AN EXAMPLE OF PROGRESSIVE, UP-TO-THE-MINUTE SMITH-SHOP ADVERTISING. THE KIND THAT BRINGS RESULTS

for being a pet customer of your jobber. When you've sold to a customer of your shop stock for which you've paid good, hard, buttons from Uncle Sam's coat, thrown in a few quarts of sweat, and several hundred volts of your own energy, make your customer cough up those buttons, some more for your sweat and energy, and some for an honest profit. In other words, collect your bills. To make collections easy—at least, to make them easier—*extend credit to no man who is a poor risk.* Keep your stock and labor in the shop and there is no risk in his case. No man is a good risk if you do not know him; and those whom you know are slow, or unreliable, are worse. Keep a good supply of "Nothing Doings" stuffed back in your cheek, and when that geezer, Poor Pay, slips you that old one—"I'll pay you next month," spill a lot of them all over him. Ten to one he'll pay cash for the job he wants done; but if he takes the job out of your shop, *you're the one who's ahead of the game.*

Don't overstock yourself with material. Of course, it is necessary to carry a supply of staple stuff, stuff



forging, welding—both on the anvil and the profitable oxy-acetylene welding, steel and tool working, vehicle building, etc., the choice of which is best decided by his particular individual taste and the demands of his trade. Any one of these will open up a wide field of study which will utilize all the spare time he is likely to have for a good many years. So choose your side line accordingly and direct all of your spare time and thought to it. It will vastly repay you in the end.

The smith who can put a heat under the hammer and bring it out conforming to the blue print or the one who understands the nature and correct handling of steel or the man who really understands the theory and science of steels are not hunting "side lines." They have one. This may read to some as a criticism on the many smiths who have had the enterprise and industry to seize the opportunity presented by some to increase their business. It is not so intended, but rather to remind them that in the shop are to be found side lines, the cultivation of which are certain to be not only profitable, but which will make of them more high-

ly respected members of a most honorable calling.

### Half a Century in the Smithing Business and Some Lessons Learned Therein

CHARLES GORSUCH

I have spent fifty years of my life in a smith shop and during that time have had occasion to observe the progress of things in general but more particular the lack of such progress among blacksmiths.

My education began at the forge long before I was in my teens. In those days there were no compulsory school laws, so my father, a master blacksmith who conducted a large and successful business for forty years, put me right at work helping him at the anvil. But all through these early days I was keeping my eyes open and learning everything I could about the business and wondering how I could improve it later on. Our work consisted mainly in a general line of blacksmithing, horseshoeing and repairs of all kinds, stage coaches and light and heavy new wagons; and we made all our

own bolts, clips, horse shoes, and horse shoe nails from the bar.

In those days blacksmiths received very little money for their work. The smith was compelled to carry his customer along for one or two years at a time and then take, in return for his work, trade instead of the coin of the realm. Accordingly he lost many a large bill.

Prices on shoeing were regulated by the prices farmers received for wheat; if wheat was 80 cents, we were paid 80 cents for four new shoes and if it happened to go up to \$1.25, we received a similar amount for our work. It was an established rule among us that when the first colt was shod, the customer had to give a quart of whiskey besides paying for the shoeing. That probably explains the general liking for John Barleycorn among the old-line blacksmiths!

A few years ago, when I was in business for myself in my father's shop, I gave credit to nearly everyone. But today I have cut out that business altogether. My business is now on a strictly cash basis and I seem to get just as much to do as ever, in spite of competition. I make it a rule to never talk about any smith who is in competition with me, nor allow anyone else to talk about him in my shop—unless we have something good to say of him. That old saying: "There's so much bad in the best of us, and so much good in the worst of us, that it scarcely behooves any of us to talk about the rest of us." Is my motto and I have found it an excellent one to follow. There's nothing that goes so far as a good word for everybody—even if it is for your worst enemy.

Prices used to be low in this section, but we organized and put a stop to cutting prices. Now we smiths get what is our just due for our work and we make our own prices, and prices that hold. If a man has to pay cash for everything he purchases elsewhere, then he must pay me cash for my own hard work. Under such conditions, the man who does the best work and is courteous and prompt will surely be successful. Before we got together, horse shoeing was as low as a dollar. Our first raise was to \$1.20, our second to \$1.40, and now we have a scale charging \$1.80 for up to No. 4 shoes and \$2.00 for No. 5 and No. 6—spot cash for all work.

In regard to purchasing supplies, I have made it a rule never to purchase anything I do not stand in

#### To My Patrons:—

On account of the greatly increased cost of raw and finished materials that are used in horseshoeing and blacksmithing I am compelled to announce an increase to become effective on April 1st, 1917, in all general prices. I have tried to be as consistent as possible in this matter, and while the prices of the various materials have advanced from 50 to 300 per cent., the advance in price to you will only average about 33 1-3 per cent.

When you or I go to a hardware, feed or grocery store we have to pay a greater price than before or we cannot buy. The same is true with my buying hardware. The only way I can replenish my stock and have it on hand to do your work well and give you the service you have a right to expect is to get the price from you with which to buy the best materials. This will enable me to serve you with the kind of work you are accustomed to get at my shop. My policy in the future will be, as it has been in the past, to give you your money's worth according to existing conditions. These conditions are such that the increase that I am naming is not nearly enough to cover the extra cost of my doing your blacksmithing business.

My shop will be closed, as usual, on Saturday afternoons during May, June, July, August and September.

Cordially yours,

R. E. WORTHINGTON.

HOW MR. WORTHINGTON, A SUCCESSFUL NEW YORK STATE BLACKSMITH, MET THE PRICE SITUATION. AN EXAMPLE OTHERS COULD PROFITABLY FOLLOW









who were victims of the ticket agent's fraudulent misuse of the English language. I am confident that that agent was an ex-real-estate shark. Anyway, his business seemed to be the selling of as little space as possible for the largest amount of money gettable. He delivered the goods.

With our mouths all set for a classy trip on the briny, we hustled down to the harbor at San Pedro to catch our boat. Of course she wasn't there at the hour she was supposed to sail, but she came six hours later, and we went aboard. A sailor or steward or purser, or something, steered us to our state-room. Honestly, that's what he called it; but if I hadn't been told it was a state-room I'd have called it a very thin clothes-closet with two shelves in it. We couldn't both go in at once, so my wife took the first go; and when she had her hand-bag and wraps on one of the shelves—berths, they called 'em—she came out and let me go in. I slid our suitcases under the bottom shelf—berth, and sized up our quarters. Some quarters! You could open or close the door, comb your hair before the mirror, get a drink of water from the hinky-dink on the wall, or turn on the light without getting out of bed. All you had to do was just reach out and do 'em; everything was so nice and "close-up".

While we were giving our home-to-be for the trip the once over and wondering how we were going to make room for two people where there was only room for the cat, we could hear the giggles and groans and cuss words of other suckers who were doing the same thing. But huh! What was a little thing like cramped quarters that it should be allowed to put a crimp in our pleasure cruise? Not so's you could notice it! I merely stretched out on my berth so the wife could come in and stand before the mirror a minute. You know, powder-puff and hair pat stuff. Then we went out on deck to get acquainted with our fellow sufferers.

We were quite a mixed bunch and going to several places. There was a schoolmarm bound for Montana; a young German couple for San Francisco; two salesmen for Spokane, Wash; a young man and wife, vaudeville actors, for Portland, Ore; an old lady and son for Tacoma, Wash; a prodigal son returning to Seattle and mother's cooking from the race course at Tia Juana, Mexico, in a more or less busted

condition, and several others who declared that they were bound to get off that ship at the first port of stop.

Our ship was returning to Portland for a cargo of lumber, and she was making the trip empty, except for the passengers, and she rode high and light in the water like an empty barrel. We had all been inclined to take the soaking the ticket agent had given us in a larky spirit. The vaudeville actor, his wife, and the two salesmen had formed a quartette had begun to sing "Rock-latest rag-time hits, and everybody was having a good time, when that little tub began to cut up capers in the choppy sea outside the harbor. The voice of one of the salesmen began to have a strained note in it. There came an expression on his face like he had lunched on a peck of green apples; a few beads of sweat popped out under his hat brim, and his lips turned white; his eyes grew uneasy and hurt like a dog with a can to his tail. The quartette had begun to sing "Rock-ed in the cradle of the deep"; and just as the salesman, who sang bass, had reached way down in his chest to spout a heavy note on the word "deep", he groaned "de-e-ep—u-u-ack!", clapped one hand over his mouth and the other on his stomach, and did a Charlie Chaplin glide to the port rail. There he hung over the rail like a pair of overalls on a clothes line and gazed down into the deep blue sea; and at every roll of the ship, he muttered "u-u-ack", and offered up the contents of his innards to the fishes below.

I left him there. In fact, we all left him there. U-u-ack seemed to be a popular word with our crowd just then, and decorating the ship's rail our favorite indoor sport. The singing and gossip stopped by popular consent, and the men threw away their smokin's. Oh, such a seasickness! I haven't been able to take salt in my soup since that trip, I have such a dislike for salt water. Some of the bunch didn't get over the sickness the whole trip. However, the second day out I was able to go into the dining room and fill up the place where all the fish feed came from. Didn't miss a meal after that.

We stopped at San Francisco for a few hours, and most of us went ashore to rubber around a bit. But we'll stop here for the present and resume our journey in next month's issue. (*To Be Continued*)

## When Purchasing Goods It Is Well to Know That Any Strings to Orders for Goods Must Be Attached to the Order Itself

The following letter touches a matter of current interest in practically all trades:—

Several weeks ago I gave a Baltimore concern an order for certain goods, to be delivered within three months. The order was quite extensive, including several items on which I had figured out the market was due to advance. The order was given to a salesman on a regular order blank which contained no conditions whatever. The salesman sent the order in and the house acknowledged it to me direct on a letter head on which was printed the following: "All orders contingent upon strikes, fire, accidents or delays beyond our control. All prices subject to change without notice." We did not notice this at the time, but found it when we looked the order up the other day. The goods did not come along when they should and as it looked like we were not going to get them, I wrote asking when we could expect delivery. The answer came back that they could not deliver at all, on account of "labor troubles in their factory." I wrote back that they had accepted a flat order from me, but they referred me to the letter head with the condition on it, and then I looked it up. Can they stand on the letter head? So far we have not gotten any of the order whatever, and if we have to go out in the market today and buy, we will lose all kinds of money.

E. R. B. & Bros.

My judgment is that the Baltimore house cannot get away with this. The law has become pretty well settled on the point, particularly within the last three years, for as every reader hereof knows, trouble over contracts since the war started has been widespread.

There is a well known New York case in which a seller tried to do this identical thing. He put small type conditions on his letterhead and then tried to cancel a contract on account of them. The court said he couldn't do it. "The language of the order is clear and explicit," said the court, "and this provision which is printed in small type, cannot be allowed to change it. It was not incorporated in the body of the order or referred to in it. Where an offer, proposal or contract is expressed in clear and explicit terms, matter printed in small type at the top or bottom of the office stationery of the writer, where it is not easily seen, is not necessarily to be considered as a part of such offer, proposal or contract."

If these conditions under which an order is taken are to have any validity, they must be a part of the order. For instance, in another case a seller printed the conditions right



down beside where the parties were to sign their names. They were under a heading "Conditions on which the above Order is Given." In that case there was trouble, and the buyer contended that he wasn't bound by the conditions because they weren't a part of the order, but here the court said they were, because they had been put where a wide-awake buyer would be sure to see them.

There are a lot of cases on the point. There is one in Illinois where the following words were printed on the extreme bottom of an order blank: "All sales subject to strikes and accidents." The court said these weren't part of the order and the seller must deliver without regard to strikes or accidents. So runs the law everywhere. As far as I know, all courts will hold to-day that the loophole conditions which so many sellers have relied on to let them out of a contract in case any one of a number of things happens, will not be enforced *unless they are made a part of the order or contract at the time it was given*. No scheme to work them into the transaction via a letter head, or even via an obscure part of the order blank itself, will be upheld any longer.

If I were advising a *seller* of merchandise how to incorporate his conditions in his contract or order blank so they would protect him, I would tell him to incorporate them in the last paragraph before the signatures. To make sure I should put this heading over it: "This Order Given and Accepted Subject to the Following Conditions," and the conditions I should print in red ink. If it were done that way the conditions would be good against anybody who signed the paper.

As a matter of fact, the feeling of all courts seems to be that these conditions are unfair to the buyer, and will therefore not be upheld except in the clearest possible case. They are unfair to the buyer because they furnish various methods by which the seller may escape from the contract, while they leave the buyer bound. How many sellers would allow a buyer to put the following in the order: "Goods not to be accepted if buyer has strike, or fire, or any accident which makes acceptance of goods impracticable at the time of delivery." Yet those loopholes are precisely what the seller reserves to himself.

Copyright 1917, by Elton J. Buckley

## The Smith in The Daily News

Odd Mention of Anvil Ringers and Knights  
of the Forge in the News of the Day

Come One! Come All! Iron Bruisers'  
Picnic—a Grand, Glorious,  
Be-e-utiful Time!

As a merry contrast to the war news comes various accounts of hammers being laid aside, fires dampened and toiling Brothers of Vulcan hieing joyfully away to the wilds of some peaceful woods or some-place-or-other to feast on boiled eggs, sandwiches, pop, etc.

Journeyman Horseshoers' Union No. 25 of San Francisco gave its annual outing and picnic at Glen Park on Sunday, August 5th. There was horse racing, rough-riding and a tug-of-war between master and journeymen horseshoers. And all told, as joyous a time that can be had when a howling band of husky smiths "let loose."

Valuable gate and game prizes were given and the proceeds were used for the sick and death benefit fund.

Guests and members of the Journeyman Horseshoers' Local No. 36 from New Bedford, Worcester, and Boston attended the annual outing and clambake of the organization held at Emery Park on August 12. The feature of the day was the athletic program in which dozens of members participated. Altogether it was estimated that more than 150 were present at the affair. In the baseball game the married men defeated the single men by the score of 9 to 2.

Two 100-yard dashes were run for special prizes. Then there was an exciting necktie race, a pipe race, quoits contest and close pool tournament to settle the local championship.

The blacksmiths of local 214, Massachusetts, held a fine field day and outing near Pittsfield.

The most interesting event of the day was a ball game between the dries and wets, the latter winning out by a close score after 11 innings.

About 200 attended a big Pennsylvania picnic at Waldameer Park on August 18.

During the afternoon a program of athletic sports was held. Winners of many prizes found it necessary to take their trophies home in motortrucks, as kegs of nails, hammers and bolt cutters were awarded.

Young Blacksmith Joins the Colors

One of Uncle Sam's most promising young soldiers is W. P. Orner, Juniata, Pa. On June 7 he enlisted at Philadelphia in the Nineteenth regiment of engineers, Company E, and expects soon to see active service in France. He is 22 years of age.

Before leaving for the Quaker City he was employed as a blacksmith in the Juniata shops and was an efficient and popular shopman. He was later employed at Philadelphia and it was while there that the call to colors found an echo in his heart. He writes home that he likes the service and is taking fifteen mile hikes and parading daily which are proving as effective in developing mammoth appetites for meals as swinging the sledge behind the anvil.

Town Wants Blacksmith

A visitor in Philadelphia was heard to express the wish that some permanent blacksmith would locate in Fayetteville, Pennsylvania, as he believes there is enough work leaving the town and neighborhood to keep more than one mechanic busy. Who will it be?

An Omaha, Neb., Shop to Shoe 300

U. S. Horses a Month

A contract for the shoeing of approximately 300 horses a month has been let to Grubbs and Company, one of Omaha's largest horseshoeing establishments.

These horses, it is said, are for the government, whose contract calls for the best work that can be done.

Blacksmith Preacher Baptizes an  
Aged Pair

"The greatest day of my life," says the blacksmith preacher, Rev. J. T. Sexton, "was when Carroll Witt, a centenarian, one hundred years, one month and one day old and his daughter who is 75 years old, were baptized." Rev. Sexton has been conducting a successful revival at Witt's Foundry, near Morristown, Virginia, and is having a number of conversions.

Gypsies Hold Up Blacksmith

After robbing Jacob Nein, a blacksmith, of Leesport, Pa., at the point of a revolver, a band of gypsies, who have been traveling around the country in great style with a seven-passenger automobile, escaped into an adjoining county with County Detective Krick and Constable John Smith at their heels.

Nein, whose shop is on the outskirts of Leesport, said the gypsies came into his place and asked for a match. While he was busy digging down into his pockets to accommodate them, he was suddenly aware that the muzzle of a big revolver was staring him in the face. The gypsies demanded all his loose change, he says. They got away with more than \$9. Think of it boys! An iron pounder with \$9 in his jeans! Marvelous, Wonderful!

According to reports, this particular band of gypsies is the sportiest aggregation ever seen in these parts. The women wear the gaudy dress usually affected by gypsies and the men have the characteristic swarthy complexions and wear earrings.

Blacksmith Barely Escapes Lynching

A Home Guard squad, of Waterbury, Conn., rescued Philip Matinuck, a local blacksmith, from an excited group of men who had rushed him with a rope around his neck to a tree, after he had shot Louis Grollman, proprietor of the Machimoodus house. They locked Matinuck in a barn and summoned Deputy Sheriff G. M. O'Neill of East Hampton and Dr. W. Plumsted of East Haddam. Grollman's wounds are not serious.

Domestic trouble between Matinuck and his wife, who is employed in the hotel, was the cause of the shooting.

Blacksmith who sent Senator Iron  
Cross Gives U.S. Four Sons

Four sons of Tom Collins, blacksmith, who sent a 40-pound iron cross to Senator James K. Vardaman when he voted against armed neutrality, will be included in the first call for the national army. They are Tom, Joe, Jimmie and Tim Collins, all unmarried. Tim Collins, a telegrapher, will join the radio corps. Jimmie Collins, the youngest son of the patriotic blacksmith, has already seen service in Texas with the First Mississippi regiment.



## Cutting Prices

With Apologies to Hamlet

To cut or not to cut. That is the question.  
Whether it is not better in the end  
To let the chap who knows not the worth  
Have the business at cut-throat prices, or  
To take up arms against his competition,  
And by opposing cut for cut, end it.

To cut—and by cutting put the other  
cutter

Out of business—'tis a consummation  
Devoutly to be wished. To cut—to slash—  
Perchance myself to get it in the neck—  
Aye—there's the rub; when one starts to  
meet

The other fellow's prices, 'tis like as not  
He's up against it good and hard.

To cut and to slash is not to end the con-  
fusion

And the many evils the trade is pestered  
with;

Nay, nay, Pauline; 'tis but the forerunner  
Of debt and mortgage such a course por-  
tends.

'Tis well to get the price the goods are  
worth

And not be bluffed into selling them for  
what

So-and-So will sell his goods for.

Price cutting doth appear unseemly

And fit only for the man who knows not  
What his goods are worth, and who, ere  
long,

By stress of making vain comparison

'Twixt bank account and liabilities,

Will make his exit from the business.

—Anon.



## Heats, Sparks, Welds

Business as usual—only more so.

Smiling when you don't feel like it is  
the only pretense that's permissible.

Give that ol' grouch o' yours a vacation  
once in awhile. It won't do either of you a  
bit of harm.

With some folks co-operation is about  
as scarce as virtue in a harem.

It takes a corking man to bottle his  
wrath.

The advertisers give valuable informa-  
tion free of charge. Write them.

Too many men turn down a paying job  
for reform work that doesn't pay.

Ever think that your eyes are your  
bread-winners? Better take good care of  
them.

"Keep cool," says the ice, and the forge  
replies: "It's bad business to lose one's  
temper in hot weather."

It takes an all round hustler these days

to make ends meet. A hen can sit still and  
earn a living, but you can't.

Fra Elbertus of East Aurora fame sage-  
ly remarked: "Anybody can cut prices,  
but it takes brains to make a better  
article."

"Having a heart" is an excellent thing in  
business as well as elsewhere; and the  
friendly feeling should be extended to  
competitors as well as to customers.

The price of beef is still traveling on the  
elevated, but Pink Buffaloes are at the  
same old level—free for the asking. A  
postal will bring a herd to your shop.

As old Ezre Cornrossel remarked  
t'other day: "I luv a rooster for 2 things.  
One iz the crow that iz in him and the  
other iz the spurs that are on him to bak  
up the crow with." If the shoe fits. . . . !

Before someone else in your town takes  
advantage of the big opportunity to  
handle that side line, go to it yourself.  
The profits might just as well be yours as  
his. It's only the difference in who gets  
there first.

There's a mint o' philosophy in the fol-  
lowing:

"He spent his health to get his wealth  
And then with might and main,  
He turned around and spent his wealth  
To get his health again."

And that's some consolation to most  
of us iron bruisers who may not expect to  
achieve great wealth, but have a profes-  
sion that keeps us well and happy from  
the very nature of it.

"Every busy dollar does it's bit," is the  
slogan of the Consumers' League of  
Indiana. "And every busy quarter does its  
two bits," pipes up young Jack, our am-  
bitious printer's devil. They both have the  
right idea—let's keep 'em busy.

Uncle Silas remarks, from his contented  
seat on the old cracker barr'l: "Feelin'  
sorry fer what you've said about a brother,  
after his friends have walked slow behind  
him, is like usin' one uv these here new-  
fangled divin' apparatuses to send him a  
life preserver."

The Trailer is becoming more popular  
every day with the farmer, the butcher,  
the merchant—in fact anyone who has a  
haulage problem to solve. And the black-  
smith's opportunity in this direction is  
growing steadily every day. Are you  
awake to the opportunity?

Did y' ever see one of those barnicles  
stickin' to a log? But you never thought  
of yourself as a barnicle stickin' to your  
shop did you? Huh? Think it over before  
you grow fast, and while the weather's  
still good, clean out for a few days with  
the wife and kids on a real vacation.

Germ-Hun Kultur is something we  
never could see. But once in a while we  
dig up something that tempers even our  
repugnance for it. Ferinstance: "It is not  
doing the thing we like to do, but liking  
the thing we have to do, that makes life  
blessed."—this from the pen of Goethe.

Are you figuring on a working profit?  
By that we mean, are you making money  
clear of constantly rising costs?—or are  
you trying to absorb the extra costs in  
your already too lean profits? As costs  
travel toward the sky line just pad your  
selling prices accordingly. It's absolutely  
necessary if you are going to pull through  
and every advance you make these days  
is justified.

Back numbers! How many times have  
we suggested that our readers carefully  
preserve all back numbers of the American  
Blacksmith? In proper shape they form a  
veritable encyclopedia of blacksmithing  
knowledge with their wealth of valuable

shop kinks, ideas, methods, and informa-  
tion on all phases of work handled by the  
modern blacksmith. The proper way to pre-  
serve back numbers in good order for ready  
reference is in bound form. Write Sub-  
scribers' Service about binders for your old  
copies of Volume 16.

A rut is what some people get into and  
never get out of. They move along forever  
like the carriage of honor at a funeral. A  
rut is a deadly thing. It is the death of  
ambition and the birth of pessimism.  
Look at the man with a chronic grouch,  
and you can bet your bottom dollar he is  
in a rut a mile deep and about a quarter  
of an inch wide; he never sees the sun  
shine from one day to another. Are you  
in a rut friend? If you are, get a move  
on; get out quick, before you grow a crop  
of boils on your disposition. The world  
never listens to the man in the rut, but it  
gives him the horse-laugh every time he  
hollers.—"Ambition."

There are a lot of slippery maxims that  
skid the wheels of opportunity. Such as:  
"What was good enough for the old man  
is good enough for me," and "Experience  
is the best teacher," etc. Pry these moss-  
backs out of your think tank and put in  
their place some good sound bricks of  
common sense such as the following: Ex-  
perience is a good teacher—if we mean the  
experience of other successful men.  
There's a new, better method in business  
found every 47 minutes—according to  
statistics. And you can't learn them all  
by your own experience. Nor can you  
spend your life in chasing around the  
country yourself in search of the exper-  
iences of others to profit by. But you can  
get them in your craft paper, and that's  
expressly what "Our Journal" is for—to  
give you in convenient systematized form  
for easy digestion, the best of other men's  
experiences.

Prices still climbing — Beginning  
August 1, Worcester, Mass. black-  
smiths raised the price of horseshoes  
from 25 to 50 per cent. Realizing only too  
well the calamity that is bound to follow  
such an action, the knights of the forge  
and anvil had refrained from taking the  
step while the cost of their raw materials  
was mounting steadily skyward, but de-  
spiration at last forced them to act in self-  
defense.

The ordinary horseshoe is to cost \$2.25  
a set, jumping from \$1.50. The bar shoes  
go from \$3. to \$3.50 a set, and the hand-  
made product from \$2.50 to \$3. All be-  
cause of the war.

The new price schedule was adopted at  
a meeting of the Worcester master black-  
smiths association. Every blacksmith in  
the city was present and all were unani-  
mous in agreeing that prices must go up.

Cost of material has in some cases more  
than doubled to the smiths in the last  
seven months. Shoes that are bought by  
the 100-pound keg, machine-made, are  
now costing \$7.50, compared to \$3 last  
January. These are the iron shoes. The  
steel ones have gone from \$7 to \$10 a  
keg.

Nails have advanced from \$3 to \$4.50  
a box of 25 pounds. Oakum is now 24  
cents a pound, against 4 cents a pound  
less than a year ago. Tar has raised to  
\$2.50 for five gallons, while the former  
price was but \$1.25.

"Blacksmiths would have been forced  
out of business if a new price list was not  
adopted at once," declared Patrick Cash-  
man, who has shod horses in his shop for  
30 years.



# Our Honor Roll

### AS GOOD AS A BOND!

That's what one reader says about his long-time subscription. It is an investment that pays for itself over and over again. Interest is paid monthly—and at a liberal rate—for every issue of "Our Journal" that is read by you adds just so much to your stock of craft knowledge. One could not ask for better security for his money. The "Blacksmith" is no new thing; it is an established craft institution. Then the concession privilege is a feature worth considering. If you die before your subscription has expired, your family receives the balance due you at your death.

A long-time subscription is an investment well worth your thoughtful attention. Read the rates below. Notice how much actual cash you can save—and get busy today.

### NEBRASKA GETTING WARM

This month's mail brings news that Nebraska has entered the ring to contest title for first place with Kansas. F. C. Bock—sort of sounds like "fighting champion" Bock—gave Mr. Krehbiel a few uppercuts. But Krehbiel is still undefeated champ and it'll take a knock-out to "get" him!

### U. S. and Mexico

2 yrs. ....	\$1.50 and save \$ .40	.....	\$2.00 and save \$ .50	.....	10 sh. save 2 sh.
3 yrs. ....	2.00 and save 1.00	.....	2.70 and save 1.05	.....	14 sh. save 4 sh.
4 yrs. ....	2.50 and save 1.50	.....	3.20 and save 1.80	.....	18 sh. save 6 sh.
5 yrs. ....	3.00 and save 2.00	.....	3.75 and save 2.50	.....	1 £ save 10 sh.
10 yrs. ....	5.00 and save 5.00	.....	7.00 and save 5.50	.....	1 £ 14 sh. save 1 £ 6 sh.

Send your order and remittance now—today. Don't wait until you forget all about it. You'll never regret it. Our subscription insurance saves you money. The sooner you begin saving, the more you save. There is no better time than NOW.

NAME	Subscription Paid to	NAME	Subscription Paid to
E. A. Krehbiel, Kans.	May, 1917	G. H. Liley, Mass.	Nov., 1925
The Fix-It Shop, Utah	July, 1935	L. Krause, Ind.	Oct., 1925
J. A. Torray, Mass.	Dec., 1933	Reynolds Brothers, Pa.	Sept., 1925
W. C. Watt, Kansas	Dec., 1930	F. W. Krens, Calif.	Aug., 1925
I. J. Stiles, N. Y.	Jan., 1929	C. E. Allen, Nebr.	Aug., 1925
Waddington Farm, W. Va.	Mar., 1928	A. E. Spangberg, Oregon	May, 1925
A. MacLean, Ont., Can.	Feb., 1928	D. M. Kille, Okla.	Apr., 1925
Plateau Shoeing Shop, Colo.	Dec., 1927	G. Gullgren, Iowa	Apr., 1925
F. C. Bock, Nebr.	Aug., 1927	G. Fredericks, Minn.	Mar., 1925
W. W. Egly, Pa.	June, 1927	V. Priessnitz, Wisc.	Mar., 1925
C. Stebbins, Jr., Kansas	May, 1927	E. Price, Illinois	Feb., 1925
J. Bruneman, Va.	May, 1927	D. C. Garber, Ohio	Feb., 1925
S. Forman, N. J.	Apr., 1927	J. H. Kurt, Illinois	Feb., 1925
H. Dyressen, S. D.	Apr., 1927	E. R. Hiteshue, Ohio	Feb., 1925
C. Shoemaker, Pa.	Mar., 1927	H. F. Schreiber, Pa.	Feb., 1925
C. Geiger, Penn.	Mar., 1927	J. S. Damm, Iowa	Jan., 1925
F. Everts, Conn.	Mar., 1927	J. M. Withers, Hawaii	Jan., 1925
P. Flanagan, Cal.	Mar., 1927	D. Teebien, Nebr.	Dec., 1924
J. Peterson, Iowa	Mar., 1927	N. B. Quick, Pa.	Dec., 1924
A. Tillman, Calif.	Feb., 1927	F. H. Jarvis, Indiana	Dec., 1924
J. W. Haught, Ill.	Feb., 1927	George Tatum, Jr., Fla.	Dec., 1924
F. Roschy, Pa.	Feb., 1927	I. Clark, Va.	Dec., 1924
J. W. Howes, Md.	Feb., 1927	A. N. Estes, Va.	Dec., 1924
W. Stocker, Texas	Feb., 1927	J. Bailey, Manitoba	Dec., 1924
W. Pontius, Iowa	Feb., 1927	E. G. Naylor, Md.	Dec., 1924
M. Goller, Pa.	Feb., 1927	Halvorson Brothers, S. D.	Nov., 1924
A. A. McLean, Nev.	Feb., 1927	P. Schicks, Washington	Nov., 1924
C. M. Adams, Conn.	Jan., 1927	H. E. Snyder, Oregon	Nov., 1924
C. Radelef, Iowa	Jan., 1927	J. A. Stewart, Ky.	Oct., 1924
P. J. Kauth, Ill.	Dec., 1926	C. Richenecker, N. Y.	Oct., 1924
A. H. Gooding, S. Aust.	Dec., 1926	W. L. Berthoff, N. J.	Oct., 1924
H. Pass, Minn.	Dec., 1926	J. W. Hewson, S. Africa	Sept., 1924
A. Granadad, Ill.	Dec., 1926	Ed. Larson, N. D.	Sept., 1924
C. J. Hale, Wash.	Dec., 1926	R. T. Monk, Illinois	Sept., 1924
John R. Schneider, Cal.	Dec., 1926	W. T. De Young, Illinois	Sept., 1924
J. C. Smith, Washington	Dec., 1926	C. W. Taylor, Pa.	Aug., 1924
H. Grimm, Utah	Dec., 1926	Charles Wells, Colorado	Aug., 1924
F. Harding, Iowa	December, 1926	H. G. Weaver, Pa.	Aug., 1924
F. L. Matlocks, Ark.	Sept., 1926	Working Men's College, Vict.	June, 1924
E. B. Jones, Wisc.	Sept., 1926	F. M. Kenoyer, Nebr.	June, 1924
J. Taylor, Calif.	Oct., 1926	O. Anderson, Ariz.	May, 1924
W. H. Branch, N. C.	Oct., 1926	R. C. Frederick, N. D.	May, 1924
J. Clarke, Jr., Queens, Aust.	Aug., 1926	H. L. Fenton, New Mexico	May, 1924
I. Boles, Ohio	July, 1926	J. Carl, Iowa	May, 1924
J. A. Buchner, Mich.	July, 1926	J. E. Little, Pa.	May, 1924
H. Mitchell, N. Y.	July, 1926	H. I. Brenzle, N. Y.	Apr., 1924
M. Broton, N. D.	June, 1926	W. E. Parr, Iowa	Apr., 1924
A. Schmitt, Nebr.	June, 1926	F. Sramek, Nebr.	Apr., 1924
D. Ackland & Son, Man.	May, 1926	L. A. Hulen, Calif.	Apr., 1924
H. Pirret, Ore.	May, 1926	J. E. Ray, Minn.	Mar., 1924
J. Sinclair, W. Australia	May, 1926	A. Hustrand, N. D.	Mar., 1924
P. Sowa, Oregon	May, 1926	W. F. Riske, Wisc.	Mar., 1924
E. P. Digan, S. Aus.	Apr., 1926	P. F. Seibert, Calif.	Mar., 1924
A. A. Peterson, Iowa	Apr., 1926	H. Roeschwetter, Mo.	Mar., 1924
G. F. Bowers, Okla.	Apr., 1926	W. E. Briant, N. J.	Mar., 1924
W. Pocheu, Oregon	Mar., 1926	A. Bosh, N. Y.	Mar., 1924
A. Garver, Ohio	Feb., 1926	D. Van Valkenburg, Mass.	Feb., 1924
C. Burton, Mass.	Mar., 1926	A. R. Johnson, R. I.	Feb., 1924
J. Murphy, Calif.	Jan., 1926	F. Jacobs, Ohio	Feb., 1924
J. F. Murphy, Nev.	Jan., 1926	A. J. Ferry, Illinois	Jan., 1924
F. Kearnes, Illinois	Jan., 1926	E. K. Walker, Calif.	Jan., 1924
J. N. McIntire, Pa.	Jan., 1926	H. D. Erskine, Vermont	Jan., 1924
W. Post, N. Y.	Jan., 1926	E. Fowler, Pa.	Jan., 1924
Powell Brothers & Whitaker, Eng-land	Jan., 1926	Breen & Son, Ireland	Dec., 1923
O. Temple, Idaho	Jan., 1926	M. Lamoreaux, Ohio	Dec., 1923
N. Karolewicz, S. Dak.	Jan., 1926	C. R. Davis, N. Y.	Dec., 1923
E. L. Lain, N. Y.	Dec., 1925	F. W. Copeland, Kansas	Dec., 1923
J. A. Hulvey, Illinois	Dec., 1925	J. L. Tomlin, Kansas	Dec., 1923
Williams & Turner, W. Va.	Dec., 1925	H. A. Davis, N. Y.	Dec., 1923
J. J. Devine, N. J.	Dec., 1925	E. H. Troyke, Illinois	Dec., 1923
P. Nelson, Minn.	Dec., 1925	D. B. Johnson, Iowa	Dec., 1923
M. Kennedy, Tas., Australia	Dec., 1925	J. M. Karrer, Ohio	February, 1923
H. Jones, England	Dec., 1925	S. Horton, Calif.	Nov., 1923
A. J. Wassmuth, Idaho	Nov., 1925	J. Spratt, Mass.	Nov., 1923
J. G. H. Mallett, Queens, Australia	Nov., 1925	F. Watkins, N. H.	Nov., 1923
A. W. Speir, Ohio	Nov., 1925	F. Koppnis, Ala.	Nov., 1923
W. R. Clepper, Texas	Nov., 1925	Y. C. Liener, S. Australia	Oct., 1923
		W. B. Abell, N. Y.	Oct., 1923
		A. J. Brookman & Co., Vict.	

NAME	Subscription Paid to
Australia	Sept., 1923
W. R. Turner, Man.	Oct., 1923
C. Nelson, Nebr.	Sept., 1923
J. Hughes, Ohio	Aug., 1923
H. M. Anderfuren, Calif.	Aug., 1923
Camp Brothers, Texas	Aug., 1923
L. C. Larson, Iowa	July, 1923
S. Effenar, South Africa	July, 1923
G. L. DeWitt, Mont.	July, 1923
W. W. Gregg, Texas	July, 1923
W. R. Stroupe, N. C.	July, 1923
O. C. Young, Michigan	June, 1923
Otto Sippel, Pa.	June, 1923
A. Chapman, N. Y.	June, 1923
C. Birely, Md.	June, 1923
F. H. Shupe, Pa.	June, 1923
J. C. Storer, Pa.	Apr., 1923
W. Schoonover, Pa.	Apr., 1923
J. M. Bumire, Iowa	May, 1923
Lowndale Brothers, Mo.	Mar., 1923
J. Carwell, Ark.	Mar., 1923
G. E. Glasier, Ohio	Mar., 1923
F. Gath & Co., S. Africa	Mar., 1923
T. Eradley, N. S. Wales	Mar., 1923
L. T. Needham, Illinois	Feb., 1923
G. C. Disinger, Miss.	Feb., 1923
J. Wieber, Minn.	Jan., 1923
Z. A. Enos, Minn.	Jan., 1923
W. G. Wise, Calif.	Jan., 1923
F. S. Bishop, South Africa	Jan., 1923
J. Curran, Arizona	Jan., 1923
S. P. Harney, Mont.	Dec., 1922
W. Breckner, Okla.	Dec., 1922
J. Pabina, Nebr.	Dec., 1922
P. Fredericksen, Iowa	Nov., 1922
L. O. Leuris, Illinois	Nov., 1922
W. Lawson, New Zealand	Nov., 1922
W. O. Grant, Calif.	Oct., 1922
W. H. Miller, Iowa	Oct., 1922
S. L. Lee, Wash.	Sept., 1922
A. O. Martin, Idaho	Sept., 1922
O. A. Mortimer, Idaho	Sept., 1922
H. J. Hyatt, Washington	Sept., 1922
J. N. Skow, Iowa	Sept., 1922
A. D. Standford, Washington	Sept., 1922
T. Temkewicz, Quebec	Sept., 1922
A. Pellifer, Ohio	Aug., 1922
W. D. Valentine, Iowa	Aug., 1922
E. T. Cull, Ky.	July, 1922
G. Hofman, N. Y.	July, 1922
J. Erman, Ark.	July, 1922
W. K. W. Hansen, Pa.	June, 1922
Robert Tochter, Calif.	June, 1922
J. Van Marter, N. Y.	June, 1922
J. T. Brahm, Iowa	June, 1922
A. Olson, Minnesota	June, 1922
Otis Alman, Mich.	June, 1922
E. Schnell, Ohio	Apr., 1922
J. Bunker, Iowa	Jan., 1922
F. Norrie, Yukon Ty.	Jan., 1922
J. Needham, Kans.	May, 1922
E. Anders & Son, S. Aus.	May, 1922
Louisa Carriage Works, Va.	May, 1922
S. Wilkin & Sons, N. Y.	Apr., 1922
R. H. Kubrta, Iowa	Apr., 1922
S. Smith, Texas	Apr., 1922
E. Burrows, Eng.	Apr., 1922
J. E. Neill, Vt.	Mar., 1922
W. Muckle, Ontario	Mar., 1922
M. Burke, Ariz.	Mar., 1922
J. W. Hodge, N. Y.	Mar., 1922
J. W. Haar, La.	Mar., 1922
D. W. Smith, Rhode Island	Mar., 1922
E. A. Dillon, Nev.	Mar., 1922
F. A. Kuster, Washington	Mar., 1922
C. A. Whitacre, Ohio	March, 1922
J. Poettgen & Co., Missouri	March, 1922
C. Robertson, South Africa	Feb., 1922
J. Zavadink, Kans.	Feb., 1922
P. C. Oldroyd, Utah	Feb., 1922
V. Vanouret, Wisc.	Feb., 1922
W. Parker, Mich.	Feb., 1922
J. DeGlopper, Mich.	Feb., 1922
Nordstrom Bros., Kans.	Feb., 1922
G. F. Johnson, Michigan	Feb., 1922
J. Schoenberger, Ohio	Jan., 1922
A. Burgett, Pa.	Jan., 1922
R. H. Keith, Iowa	Jan., 1922
W. Parks, Ohio	Jan., 1922
O. Dannemann, Minn.	Jan., 1922
O. Stenning, S. D.	Jan., 1922
W. Claffey, Illinois	January, 1922
J. J. Kilma, Nebr.	Dec., 1921
J. Boyer, Mich.	Dec., 1921
C. F. Shaw, Man., Can.	Dec., 1921
W. Bisker, Ohio	Dec., 1921
W. Lambertson, N. Y.	Dec., 1921
Scheffey & Schmitt, Pa.	Dec., 1921
O. Furry, Kans.	Dec., 1921
E. A. Pierson, Okla.	Dec., 1921
J. Robertson, Scot.	Dec., 1921
J. Lauer, Mo.	Dec., 1921
A. Brause, Ohio	Dec., 1921
B. A. Abbey, Ohio	Dec., 1921
J. Ingranson, Minn.	Dec., 1921
A. F. Millebrandt, Mich.	Dec., 1921
J. H. Teufel, Jr., Illinois	Dec., 1921
R. C. Brown, Mo.	Dec., 1921
C. Beyer, N. D.	Dec., 1921
G. Nichols, Okla.	Dec., 1921
F. H. Joslin, Mass.	Dec., 1921
J. B. Scheidler, Indiana	Dec., 1921
J. H. Ickes, Pa.	Dec., 1921
E. Willis, Colorado	Dec., 1921

NAME	Subscription Paid to
A. Elliott, England	Nov., 1921
J. Beam, N. J.	Nov., 1921
F. Kolarik, Iowa	Nov., 1921
A. McNab, Scotland	Nov., 1921
J. Delane, Nebr.	Nov., 1921
A. Marks, N. S. W., Aust.	Nov., 1921
O. R. Stevenson, Ill.	Nov., 1921
J. Meier, Minn.	Nov., 1921
J. O. Aitkin, Aust.	Oct., 1921
W. Knouff, Ala.	Oct., 1921
O. M. Johnson, Miss.	Oct., 1921
J. K. Glinicki, Mich.	Sept., 1921
H. Feldus, Nebr.	Sept., 1921
R. Murray, Calif.	Sept., 1921
A. Hammond, Calif.	Sept., 1921
P. Wedel, Kans.	Sept., 1921
J. Ackerman, Indiana	Sept., 1921
A. Harper, Mont.	Aug., 1921
L. E. Bonton	Aug., 1921
J. Watson, S. Africa	July, 1921
R. Goldschagg, S. Africa	July, 1921
C. Hammerstran, Minn.	July, 1921
A. S. Pratt, New York	July, 1921
E. H. Spain, Ariz.	July, 1921
L. H. Strange, Vict., Aust.	July, 1921
W. Urquhart, New Zealand	June, 1921
W. Voigt, S. Africa	June, 1921
J. M. Wert, Pa.	June, 1921
E. Toll, New Zealand	June, 1921
G. Johnson, Kans.	May, 1921
S. Budds, New Guinea	May, 1921
H. Baker, Australia	May, 1921
F. E. Smith, Vermont	May, 1921
A. J. Hatch, Maine	May, 1921
W. Cornwall, Pa.	May, 1921
W. F. Kline, Kansas	May, 1921
J. Kirkbride, N. J.	May, 1921
Thos. McNeill, Scot.	May, 1921
T. Holloway, Kans.	Apr., 1921
W. Winget, Vt.	Apr., 1921
J. A. Johnson, N. D.	Apr., 1921
D. H. Laird, N. Y.	Apr., 1921
A. J. Prue, N. Y.	Apr., 1921
C. A. Butler, Ohio	Apr., 1921
E. Moesner, Queens, Australia	Apr., 1921
J. Laux, Oklahoma	April, 1921
C. L. Coase, Pa.	Mar., 1921
E. Lindblad, Nebr.	Mar., 1921
F. Bowen, N. Y.	March, 1921
W. F. Tippey, Mich.	Mar., 1921
J. T. Rehm & Son, N. Y.	Mar., 1921
W. C. LeBow, Mo.	Mar., 1921
William Pate, Mo.	Mar., 1921
A. T. Jameson, Colorado	Mar., 1921
C. Alexander, N. Y.	Mar., 1921
J. Fencil, Wisc.	Mar., 1921
H. Cornils, Oregon	Mar., 1921
C. Schmid, Nebr.	Mar., 1921
J. Schwarzmann, D. C.	Mar., 1921
M. Stettner, Minn.	Mar., 1921
Elmer Wetzel, N. J.	Feb., 1921
J. Potthoff, Nebr.	Feb., 1921
N. E. Hart, Okla.	Feb., 1921
C. Knudson, Iowa	Feb., 1921
S. Button, Kans.	Feb., 1921
N. F. Hartsoe, Mo.	Feb., 1921
I. Qoeple, N. Y.	Feb., 1921
R. E. Worthington, N. Y.	Feb., 1921
B. E. Doggett, Kansas	Feb., 1921
Sbellhaas & Fry, Colorado	Feb., 1921
J. Toees, Kansas	Feb., 1921
J. W. Wilson, Mo.	Feb., 1921
W. T. Wilson, Indiana	Feb., 1921
J. Schmid, Nebr.	Feb., 1921
E. Snee, New York	Feb., 1921
A. R. Skeritt, New York	Feb., 1921
W. H. Starkey, Kans.	Feb., 1921
W. Singleton, Pa.	Feb., 1921
E. N. English, Iowa	Jan., 1921
H. Becker, Ill.	Jan., 1921
G. Tice, N. J.	Jan., 1921
J. Briere, Vt.	Jan., 1921
A. Bartlett, Vt.	Jan., 1921
E. H. Manley, Mo.	Jan., 1921
Neufeld & Giesbrecht, Kans.	Jan., 1921
W. C. Abbott, Ohio	Jan., 1921
Feldmeyer & Schaake, Mo.	Jan., 1921
A. Josepfit, Colorado	Jan., 1921
C. L. McNeill, Mo.	Jan., 1921
A. Turley, Kansas	Jan., 1921
A. Seidel, Nebr.	Jan., 1921
W. Ruple, Pa.	Jan., 1921
N. A. Enguld, Iowa	Jan., 1921
O. Gerhardtstein, Ohio	Jan., 1921
W. C. Rutter, Illinois	Jan., 1921
J. L. Jester, Mo.	Jan., 1921
G. A. Moffatt, Yukon Ty.	Jan., 1921
F. Fisher, S. D.	Jan., 1921
J. H. Winn, Iowa	January, 1921
A. L. Schwartz, Iowa	Dec., 1920
S. Barber, Iowa	Dec., 1920
A. Warner, Idaho	Dec., 1920
J. W. Ivie, Utah	Dec., 1920
O. A. Huff, Pa.	Dec., 1920
J. T. Rowe, Iowa	Dec., 1920
W. Parsons, Ontario	Dec., 1920
Eiasier Brothers, S. Dak.	Dec., 1920
J. Krabulec, Illinois	Dec., 1920
L. F. Keilholz, Pa.	Dec., 1920
F. Markgraf, Minn.	Dec., 1920
S. Wright, New York	Dec., 1920
T. P. Considine, Mass.	Dec., 1920
J. D. Fox, Nebr.	Dec., 1920
W. Treener, Washington	Dec., 1920

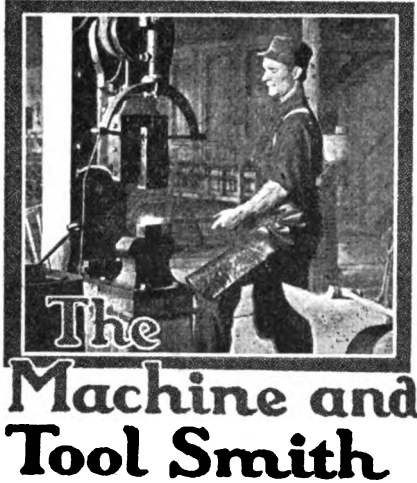

## Rock Drills

JAMES STEELMAN

The blacksmith's duties, in connection with the care of rock drills are regarded as of very high importance. The following quotation from a book entitled "Rock Drilling," by Richard T. Dana and W. L. Saunders, lays considerable stress on this point:

"To emphasize the importance of having a good blacksmith, perhaps it is enough to say that, if the efficiency of the best blacksmith in the United States could be increased 50% by quadrupling his pay, it would be economy to do so for any drilling work."

Because rock drilling is going on everywhere in connection with

foundations of buildings, etc., it would be well for the enterprising blacksmith to become fully informed concerning the drills used and the best methods of caring for them.

Simply because the blacksmith has been successful for years in tempering and hardening chisels, axes, etc., it does not follow that he can succeed in like measure with rock drills unless he knows what he is up against. It is far better to learn precisely what the game is. Then his previous knowledge will doubtless help him to become a cracker-jack player.

The blacksmith may be a specialist in rock drilling and have a job with some mining or contracting company, or he may be doing general work and have rock drill-bits brought to him. In any case, the wisest thing to do is to familiarize himself with this work and learn how it differs from other jobs.

In the first place several things must be kept in mind in order to secure the best results in caring for rock drills: (1) proper hardening; (2) proper sharpening; and (3) rapidity in handling the work.

Permit me to quote again from the same book:

"The proper tempering of the bits is absolutely essential. On one job that we inspected, on which the contractor wanted to know why he was losing money, we found that the blacksmith heated his drills up to the lowest kind of a low red before quenching. He might as well have

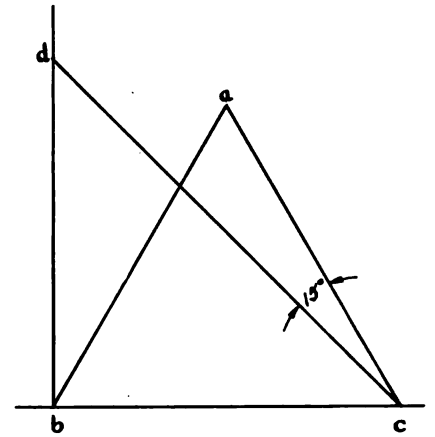

FIG. 1.—TO FIND AN ANGLE OF 15°, CONSTRUCT A TRIANGLE HAVING ALL THREE SIDES EQUAL, AS THE TRIANGLE, A-B-C. AT B ERECT A PERPENDICULAR LINE EQUAL IN LENGTH TO A-B. DRAW A LINE FROM ITS END, D, TO C. THE AROWS INDICATE THE ANGLE OF 15° FORMED BETWEEN A-C AND D-C.

"The average blacksmith with a helper can sharpen by hand about 140 bits a day, which ordinarily will supply six machines in hard rock.

"With a bit-sharpening machine, one man can average 50 drills per hour and the bits are harder, denser, and better formed than the hand-sharpened ones."

Power-driven rock drills are employed, ordinarily, for drilling into rock for the purpose of providing holes for the reception of dynamite or some other blasting explosive. Drilling for water wells and oil wells is a different thing. So also is the drilling of deep holes in connection with mining operations. That is, the drills used here, such as churn-drills, diamond-drills and short-drills, are more or less different from rock drills in construction and in mode of operation. However, it may be well to state that there is a type of hand-operated churn-drill which is very effective in drilling blast holes in rock.

There are two main types of power-driven rock drills. First, we have the *percussive* drill. This drill is operated by being lifted and then made to strike a blow. Second, we have the *hammer* drill. The operation of this drill is accomplished by striking the drill on one end with a ram or hammer. In the former case, the drill-bit itself strikes the blow; in the latter, the force of the blow is transmitted through the bit.

The power-operated drill-bits are of numerous shapes. In very nearly all cases, however, the maximum

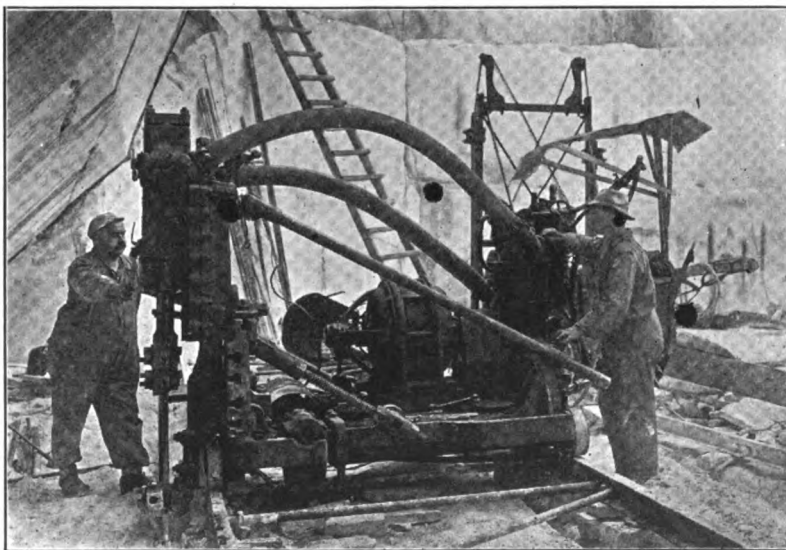

From the "Travelers' Standard." (Courtesy the Travelers' Insurance Co.)

### A ROCK-CHANNELING MACHINE AT WORK IN A QUARRY.

mines, railroad construction work, excavation, road building, in the construction of gas and water mains, in quarrying, well-drilling, laying the

tried to harden them with cigarette ash."

The sharpening may be done by hand or with the aid of a machine.



diameter of the cutting face is larger than the diameter of the stock. A drill-face  $1\frac{3}{4}$  inches across, with a shank of one inch is not at all unusual. And there may be on this face one, two, or three chisel edges, each extending all the way across.

Let us first consider an ordinary cross or square bit (See Fig 2, A and B). Here we find two chisel edges which cross each other at right angles. We thus have a square with the chisel edges forming its diagonals. Naturally these chisel edges must have a heavier and thicker metal backing than the edges themselves, and a space must be provided between opposite chisels. So we find the metal ground away between these edges in the form of angular depressions in the face and along the shank of the bit. Although the stock may be widened out at the end to provide proper widths for the chisel edges, this widening does not involve a greater amount of metal than the shank itself. This is because only the sides of the chisels taper out, while there may be flutes between them in the shank. Thus if the stock is, say, one inch in diameter, the thickness of each of the four wings forming the cutting end may properly be  $\frac{9}{16}$  of an inch. The bevel between is exactly 90 degrees. If the edges are either much sharper or much blunter, we may expect "mudding"—that is, the bits of rock cut off will not be thrown back out as they should. But the 90 degree edge "muds" well.

The tapering of these opposite wings from the perpendicular of the shank may be 15 or 16 degrees. (An easy way to determine an angle of 15 degrees, if no calipers or scale is handy, is to lay one off on a sheet of paper as shown in Fig. 1).

The face of the bit should be absolutely flat; that is, so that if it is laid on a level surface, all points on each chisel face will touch.

The very edge of the chisel bevel should be the exact diameter of the hole. So much for the tip edge of the bevel. Now for the base of the bevel. This should fall into the same circular cross-section of the hole, and should neither fall inside nor extend beyond. If the blacksmith uses a short piece of tubing for a gage, he will be able readily to determine these points. Thus, suppose he is making a cross-bit with flat face  $1\frac{3}{4}$  inches in diameter from 1-inch stock. A  $\frac{3}{4}$  inch length of tube that is just  $1\frac{3}{4}$  inches inside diameter will do very well. A rod could be attached

to this ring to serve as a handle. When this ring is put over the bit, the ends of the edges of the bevels should just touch the inside surface of the ring. Also, the bottom corners

the effect of tending to keep the hole round. With the cross-bit, however, the bit is, in effect, in exactly the same position every other blow. Under some circumstances, this is

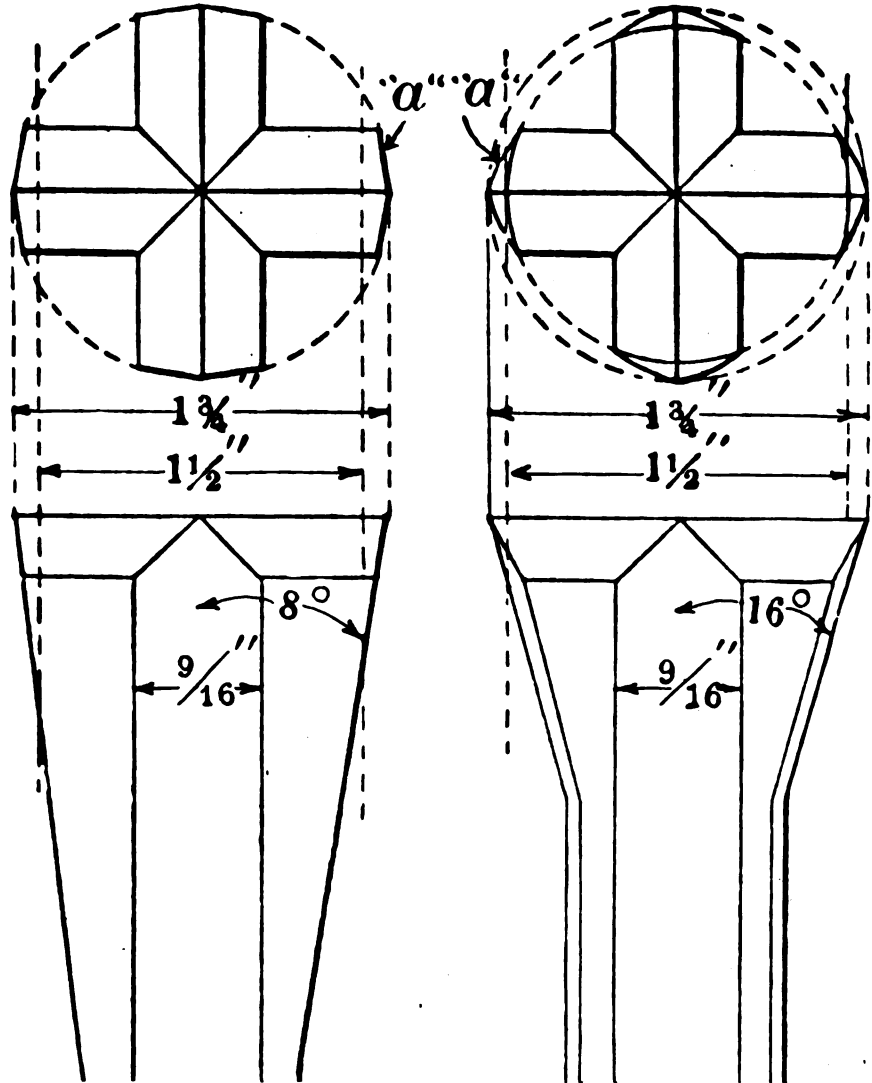

FIG. 2-A. TWO FORMS OF THE ORDINARY CROSS OR SQUARE BIT. THE CHIEF DISTINCTION IS IN THE TAPER, ONE BEING 8° AND THE OTHER 16°

of the bevels should just touch the same surface.

Assuming that the foregoing account of the flat-face (straight-edge) cross-bit has been understood, it will not be difficult to describe other forms.

There is a form of bit—the Simmons bit (See Fig. 3)—which has but one chisel edge extending from side to side. Here are, as in the cross-bit, two more wings, but they have no cutting edges to cut the rock in the bottom, horizontal surface of the hole. These two wings are useful, however, in keeping the hole round and free from rifles.

It may be as well to explain here, before going any further, that it is standard practice to twist the bit  $\frac{1}{8}$  of a turn between blows. This has

undesirable. Two forms of bit aim to overcome this trouble.

The Brunton bit is similar to the cross-bit, only it breaks up the chisel edges running from one side to the other. Each chisel edge is broken into two parts and these are displaced enough to hinder them from forming a straight line; but the two parts (each is really less than a half) are kept parallel. This bit has to make a full half turn before it is in exactly the same position as before. It is said to be used largely in Idaho and Montana.

The X-bit is another form which seeks to avoid the disadvantage of the cross-bit in coming to the same position every second turn. Instead of the two chisel edges being at right angles, they are set so that two of





the angles are more acute and two are more blunt. Wherever the sharpening machines are used, this bit seems to be losing favor. The rea-

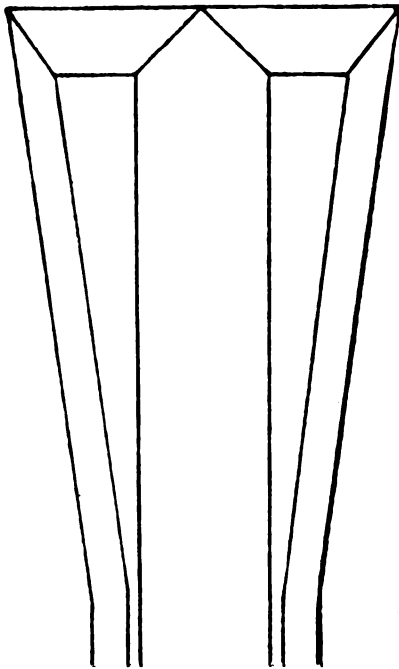
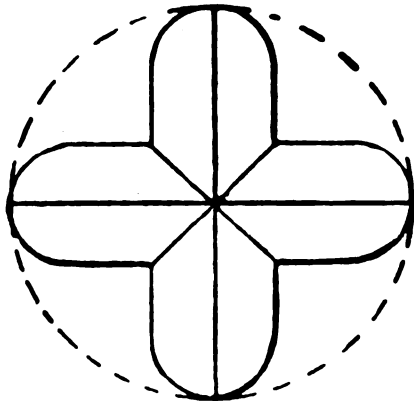

FIG 2-B. A SPECIAL FORM OF THE CROSS BIT.

son appears to be that the cross-bit as sharpened by the machines will not make rifles in the hole; so that the X-bit becomes unnecessary.

Sometimes bits are formed so that the chisel edges will not everywhere touch a flat surface. That is, the chisel edges are rounded so that only the *center portions* of each chisel edge will touch the flat bottom of a hole; or they are rounded so that only the *ends* of the edges touch it. The bit with two chisel edges at right angles and rounded so that the center is in advance of the rest of the face is the *Cornish* bit. It seems to have had a period of unpopularity in the United States; but this is passing now, because it has been found that the *Cornish* bit is a fine tool to *start* a hole with when using the power-

driven hammer drill. "For a starting bit in hammer machines it has no equal." But it does not seem to be suited to follow up the start, having a tendency to follow seams and cracks in the rocks. The bit which has the ends of its edge in advance of the center is understood to be a fast cutting tool. However, the corners are liable to break off unless the blacksmith uses extreme care in hardening and tempering.

Sometimes, a flat face bit is made by arranging three half edges at 120 degrees from one another (See Fig. 8). That is, each chisel edge runs from the center out to the circumference instead of from one side to the other. The advantage seems to consist mostly in the increased angle between wings, this permitting greater ease in "mudding."

There are various other styles of bits, which it will be unnecessary for our purposes to describe in detail. Let it be thoroughly understood, however, that the various peculiarities of shape are not to be regarded as unimportant or mere freaks. It will be the blacksmith's business, in any case, to take a worn bit and bring it back to its proper form and hardness. Naturally, certain parts will wear faster than others; so that the blacksmith will have to build out such parts to a greater degree than the others.

An ordinary *hand drill* is a simple affair. (See Fig. 9). It is simply a bar of steel spread and sharpened at the cutting end and given a striking head at the upper end. The cutting edge consists of a single chisel edge. This edge is usually rounded. The width of the cutting edge will be anywhere from one-third as wide again as the stock, to twice the width of the stock. The chisel edge may be given a double bevel amounting to a full right angle—90 degrees; or it may be made sharper, so sharp in some cases that the double bevel amounts to only half a right angle—45 degrees. The blunter edges are used in hard rock and in soft sandstone having large grains; the sharper edges, in softer rock in general. Hand drills are made from drill stock up to  $\frac{3}{4}$  and 1 inch sizes. Ordinarily, hand drills may very readily be reshaped and sharpened by simple methods.

One of the first things a blacksmith must attend to is the character of the fuel. Coal may be used, provided there is little or no *sulphur* in it. It is understood that the sulphur, if present, is apt to aid in burning

the carbon in the steel. Such steel is known as "burnt steel." About the only thing a burnt piece of steel is fit for is the scrap pile. However, steel may be burnt otherwise than by sulphur. If the heat is too high or the exposure to the air too great, we are apt to do some burning. Drill-steel of the ordinary kind (i. e., not high speed steel) contains anywhere from 0.80 to 1.00 per cent. of carbon. It is advised—by Gillette—that the heating be not carried beyond *cherry red* and then the air blast be not too strong. The bit which is to be reshaped should be well covered by the bed of coals. In order to get a uniform effect upon the bit, the blacksmith should turn it over in the fire. When the bit has been heated up to a dull *cherry red*, it is ready for forging. It is then taken quickly to the anvil. "If the corners of the

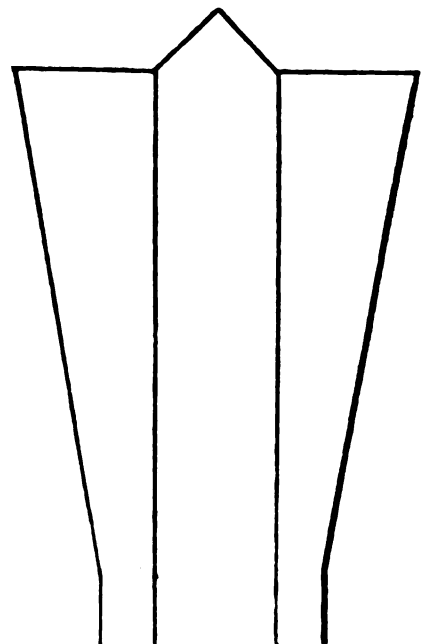
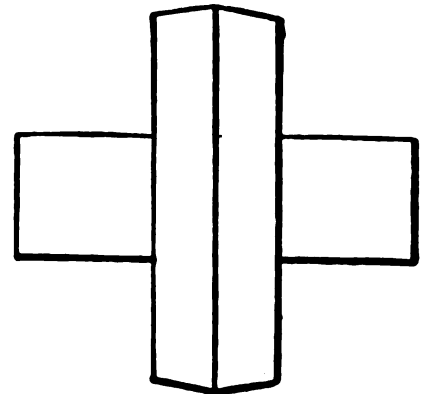

FIG. 3—THE SIMMONS BIT.

bit are badly worn, the chisel edge must first be upset—to give the proper width; then the drill is held on the anvil at a slope of about 1 foot rise to 2 feet horizontal, the



edge of the bit being even with the edge of the anvil. In this position it is hammered and turned over at intervals, until a new cutting edge is made. A file may be used—while the bit is still hot—for the final shaping. If the drill is simply dull, it is not necessary to upset it; but when taken from the fire it is tapped or brushed to remove any cinders, laid on the anvil and struck with light glancing blows until an edge has been formed. The blows should be glancing so as to draw the steel fibers toward the cutting edge, and the lighter the blows that will accomplish this result, the tougher the steel becomes.” The blacksmith should be careful not to get the bit more to one side of the stock than the other. If the

always given uniform diameters. The hardening and tempering constitute what may be called the heat treatment. First, the hardening. We re-heat the bit to a *cherry red*. If the steel has no more than 0.80 per cent carbon the hardening heat may be made a *full cherry red*; if the carbon percentage is higher, then let the hardening heat fall somewhat *below full cherry red* — the more carbon the less heat. Care should be taken not to expose the bit unduly and in general to take the same care as before. It should now be plunged into water. The drill should be held exactly in the position it will occupy when in use and then plunged suddenly into the water. Do not put it into the water sideways or in any other way than that just described. When the bit has cooled down to a point just a little above the tempering range (dark-blue to very pale yellow), we may take it out and do the tempering with the same heat used for hardening. We clean off the surface to permit the tempering colors to be seen by rubbing on a stone or otherwise. “As the drill cools, the colors should advance parallel to the cutting edge, if the cooling is uniform; if otherwise, that side of the bit on which the colors are advancing most rapidly should be held in water. This plunging into the water is sometimes repeated several times before the colors move parallel with the edge of the bit. Finally, when the colors move parallel with the edge, watch the edge closely until it is straw color and plunge into water a short distance, waving it back and forth (to insure rapid cooling) until the steam ceases to form; then leave it in the quenching bath. The quenching bath should be a tub large enough to cool the drills without raising the temperature of the water sensibly. Some of the baths commonly used are brine, water, rape-seed oil, tallow and coal tar; the brine cooling the drill fastest and the coal tar slowest.”

The foregoing account has in view the utilization of the hardening heat for the tempering operation. I think it is preferable to let the drill cool off, say, to the temperature of the shop and then heat the bit up especially for the tempering. In justification of this preference I would call attention to the irregularity in the cooling that seems to be expected as possible with the one-heat method, when the drill has been removed from the hardening bath and the

tempering colors are appearing. There has been a cooling down from cherry red through a long range. There has been, accordingly, a good deal of opportunity for differences

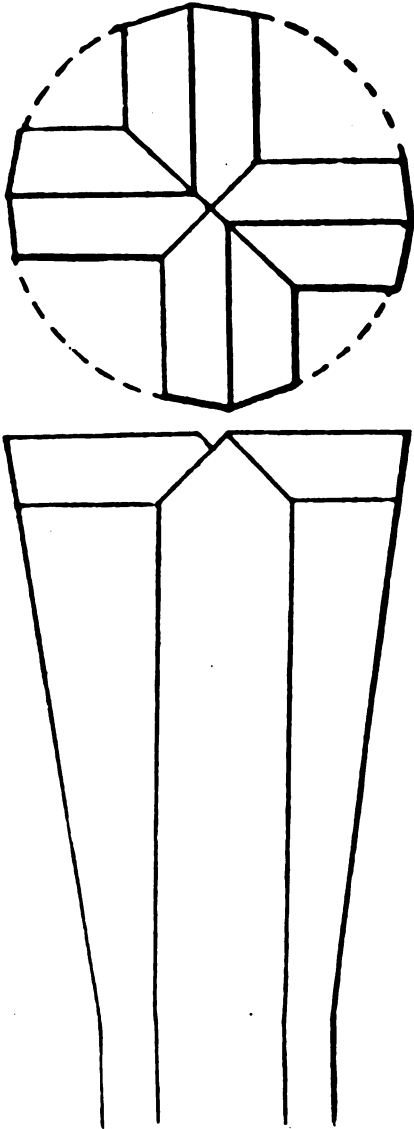

FIG. 4—THE BRUNTON BIT.

hole being drilled by the hand drill becomes ultimately rather deep, it will ordinarily be necessary to narrow the bits from time to time, as holes of considerable depth are not

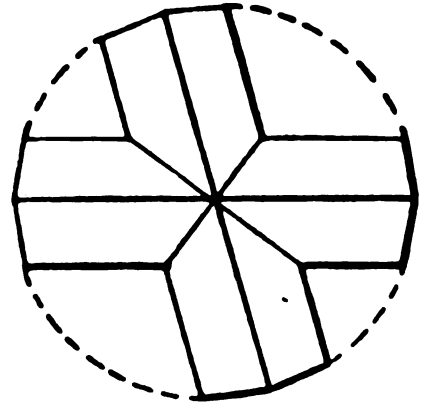

FIG. 5—THE X BIT.

of temperature to be simultaneously present in different parts of the bit. The partial cooling off in the hardening bath may have affected one side of the bit more than the other side because of the position of the drill in the bath. If, however, we heat up from the shop temperature, we can control matters so that one side is heated at the same rate as the other. Then we will not have to be dipping one side two or three times into the water to check the temperature change. However, if there is not



time available for a re-heating for tempering, or some other reason requires us to utilize the hardening heat, then let the drills hang vertically in the cooling bath until they

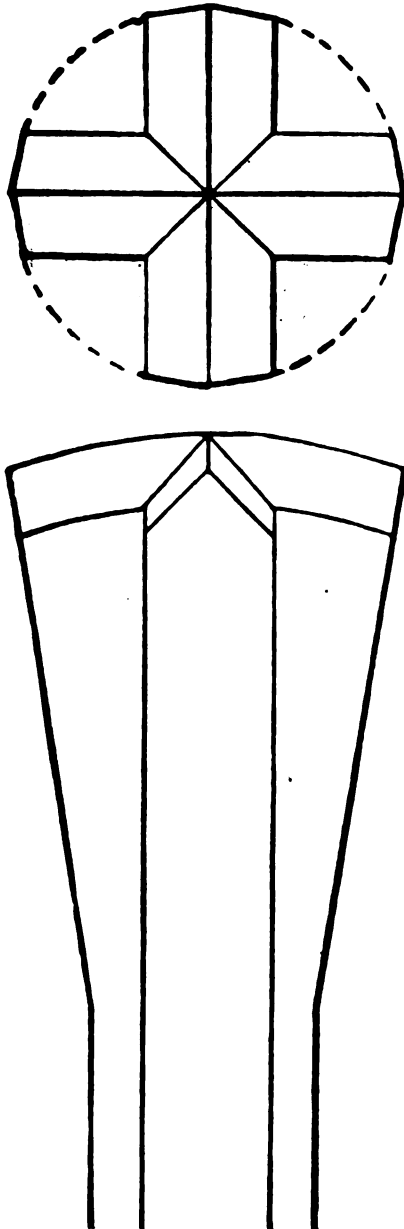

FIG. 6—THE CORNISH BIT

are taken out to temper. The idea is to favor both sides, all sides, the same. Also, the hardening heat should be on both sides, and this will be difficult to get, unless we heat for the hardening in some better way than by merely putting the bits into a fire and occasionally turning them over. On the whole, it would seem best, if it is at all possible, to heat up especially for the tempering operation.

Where drills are operated by machines, they are apt to have complicated bits and likely to be heavy.

They may be re-shaped and sharpened by hand methods or by means of special machines. Where hand methods are employed, we shall need several special tools to enable us to get the right chisel edges and other forms. One of the most important of these tools is the *dolly* (See Fig. 10). This is a kind of die and is used to give the exact form to the face of the bit. It has, if for a cross-bit, two grooves at right angles on its own face. These have the form and size suited to "mold" the two chisel edges which intersect at right angles on the face of the bit. Naturally, the grooves will be curved or straight in accordance with the requirements. A dolly for an X-bit will have its grooves suitably set, and so with the other varieties. In general, it will be best for the blacksmith to provide himself not merely with a separate dolly for the different types of bit, but with a separate dolly for each size of a style. A dolly may be made from a new bit by pressing or driving the latter in its cold state against a heated block of steel, thus forcing the face of the block into the correct form for a dolly. Naturally, the temper will be drawn from the new bit and will have to be restored. The block should now be hardened and given a fairly hard temper. Care should be taken in doing this work that no distortion occurs. When finished, the face of the dolly may be tested to see if it is sufficiently perfect. The dolly may be arranged on the anvil to permit a heated bit to be driven against it and get its proper form, the drill being held horizontal. Sometimes, however, more powerful efforts will be necessary than can easily be given with a sledge swung for a horizontal blow. A suitable slot or hole may be arranged in a short shank back of the dolly and a handle used in it to permit the dolly to be held in position for vertical blows from a sledge in the hands of the helper.

Other special tools needed are: *top splitting tool, set hammer, top shank swage, bottom shank swage* and the *sow*. By means of the foregoing, the blacksmith is enabled to give the proper shapes and sizes to the bit and its parts and to do the work correctly and quickly. A caution may be set down here. It seems that by the time the helper got to the point of using the sledge on a dolly to force the face of an old bit to proper form he would be good and tired; so that the result has been an ill formed bit, unsuited to

its work. The chisel edges would be left too sharp and perhaps with an undesired curvature. It would be better to heat the work once more and force the dolly home.

We now come to what is perhaps the most serious part of our consideration of the blacksmith's work with rock drills used in power driven machines. I refer to the hardening and tempering. It is understood that a great deal of such work has been done wrongly in the past. It is not sufficient that the blacksmith use his general knowl-

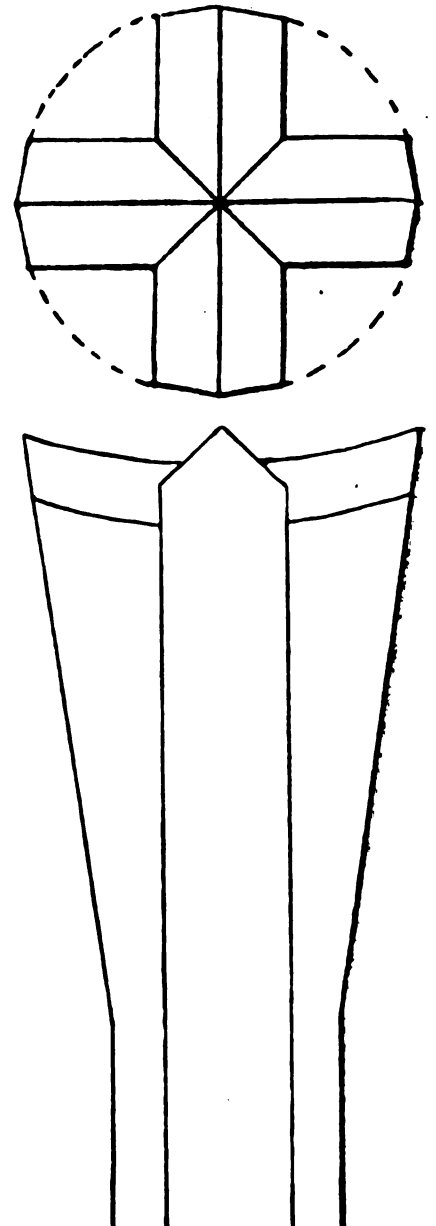

FIG. 7—THE CONCAVE BIT

edge of hardening and tempering and than he does what he calls "a pretty good job." "A pretty good job" isn't what is wanted. Consider a moment. If the bit does not have hardness where hardness is



needed and toughness where toughness is needed, then the operation of that tool will be ineffective. This means loss of time and money, for the machine will not permit the operators to give proper returns in the shape of drilled hole. There may be a considerable group of machines. If the blacksmith does not have a method of hardening and tempering which gets everything out of the bit that it is possible to get, then there is loss with all these machines and the men with them.

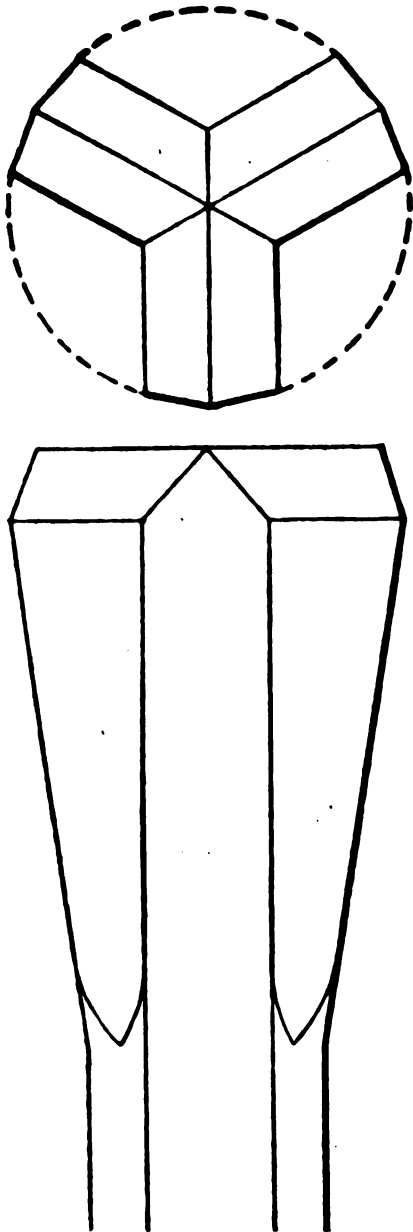

FIG. 8—A FLAT-FACE BIT WITH ONLY THREE WINGS. DESIGNED TO FACILITATE EASE IN "MUDDING"

which come in contact with the cylindrical wall of the hole and which perform a reaming effect. When we have mentioned the chisel edges and their ends, we have mentioned just about everything that really needs to be hard. Hardness elsewhere may be an advantage or a disadvantage. We want a *tough* backing for the parts mentioned. Also, we want a *stiff* backing. Now hardness goes with stiffness but not as a rule with toughness. If we make a piece of the steel hard, we usually make it stiffer and we also usually make it less tough. The problem accordingly is a nice one. In practice, it is found well to limit the hardness of the drill-bit pretty close to the face and have the portions back of it softer and consequently tougher. Doubtless, there is considerable loss of stiffness. This is partially compensated for by the broad bases of the chisel edges. The shock, during drilling, comes on the sharp tip of the edge; but this edge is backed up by the broad base of the double bevel. So, the blacksmith should harden a bit, not by dipping the whole bit into water, but by dipping just the face to a very short depth.

The common, ordinary method is understood to be all wrong. In accordance with it, the immersion of the face is perhaps an inch deep. It produces a bit face which is hard on the wings and tends to be softer at the center. The reason appears to be this: When the cherry red bit is plunged into the hardening bath, the thin parts cool off with great rapidity and become good and hard. This is due partly to the thinness and partly to the fact that the wings are surrounded on nearly three sides by the cooling liquid. The center of the bit, however, contains more metal and metal not well reached by the quenching bath, and so it cools more slowly, with the result that the hardening at the center of the face is imperfect or is quite shallow. When the bit is applied in operation the center of the face wears faster, either because it isn't as hard as the wings or because the hard shell is there soon worn through. Dana and Saunders say in their book on *Rock Drilling*, quoting from T. H. Proske: "Perhaps the center had not chilled at all when the bit is withdrawn for annealing (tempering) and the final result is a soft center-bit, which will flatten and retard the work of drilling."

The practice of plunging the

whole bit into the water in an attempt to temper with the forging heat is also condemned. Likewise, condemnation falls upon the practice of chilling the steel back of the

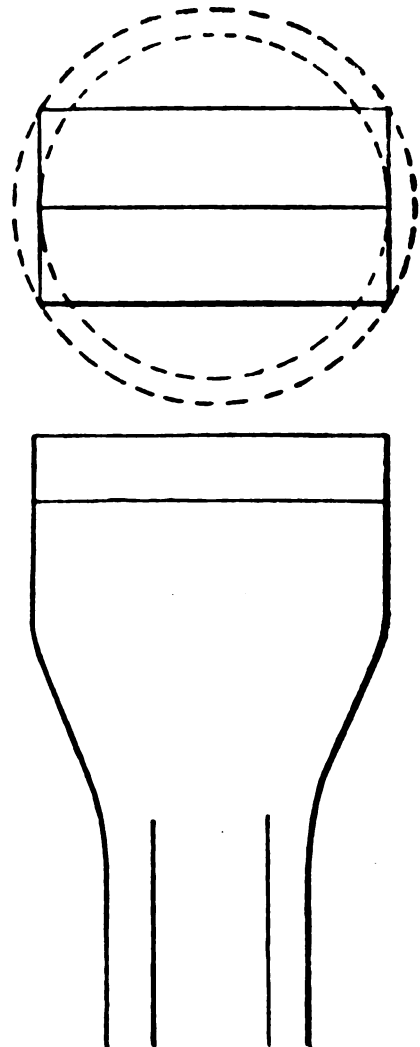

FIG. 9-A—SINGLE-EDGE HAND DRILL

face and then plunging the bit as a whole.

It is desirable to immerse the bit just about  $\frac{3}{4}$ -inch and in addition have a continuous change of water. The region of hardening is in this way limited to the face and just back of it and a continued chilling effect is produced. Simply to dip the face of the bit into a tub of water to a depth of  $\frac{3}{4}$ -inch is not enough, it would appear, according to Proske, approvingly quoted by Dana and Saunders. It is desirable, therefore, to provide a special piece of apparatus. The whole is quite simple, and may easily be made (See Fig. 11). A tank of wood or other material is provided with an inlet tube which discharges water into a body of water about 9 or 10 inches deep. That is, the supply tube is brought in through the bottom or at one side

Also the ends of the chisel edges Merely "a pretty good job" is not good enough.

The chisel edges need to be hard, because they do the cutting through which the advance is made in depth.



in such a way as to discharge at the level of, say, 3 inches from the bottom. An outlet is arranged at a distance from the incoming jet. This outlet is placed, say 10 inches above

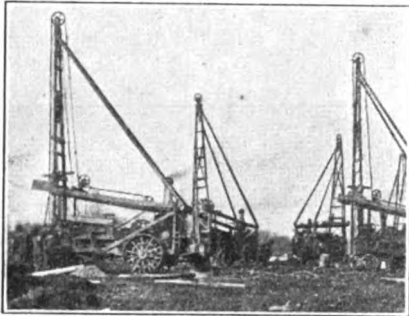

**DRILLING BLAST HOLES IN ROCK**

(Courtesy Keystone Driller Company)

the bottom. These arrangements have in view the provision of a body of water which is flowing at the top, at least, and which will constantly remain at a fixed level. Perhaps a little experimentation will be needed to secure these results. The size of the outlet tube may need changing or that of the incoming jet. A false bottom in the form of a grate is to be arranged at such a level as to have  $\frac{3}{4}$ -inch of flowing water above

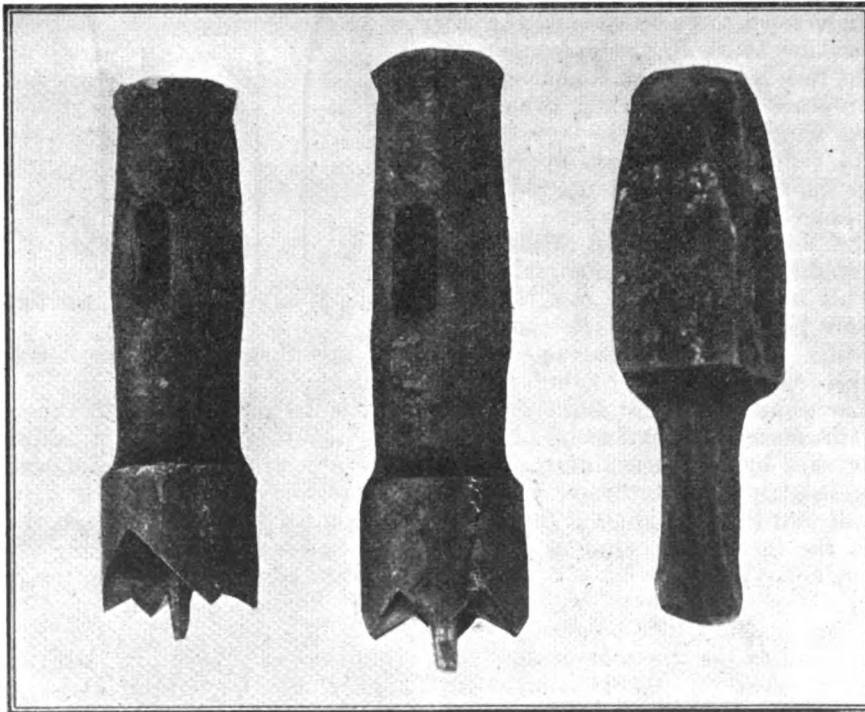

**FIG. 10—DOLLIES AND GAUGE FOR DRILL BITS**

it. The afore-suggested experiment would better take place after this false bottom is in place. As perhaps the smith has already guessed, the flowing water,  $\frac{3}{4}$ -inch deep, is to be used for the hardening bath. The bits are stood up, faces down

and resting on the grate, and get a pre-determined, exact amount of immersion. By arranging a simple rack the smith may be able to set up in place half a dozen or more bits at a time. Let it be remembered that it is quite important that the bits be stood up perfectly vertical—leaning neither this way nor that. A rack may be arranged on two sides of the tank. It is easily made by driving pegs into a strip of wood. The pegs are set at such an interval as will accommodate the shank of the bit.

Drill-steel for rock drilling comes in several forms—round, hexagonal, octagonal and cruciform. Sometimes a central core is removed, leaving the steel with a hollow in the center. The cruciform bar is especially suited for making certain bits, as its shape saves the blacksmith from the necessity of performing certain operations.

There are drill-sharpening machines by whose aid the blacksmith can get out much more work. In two prominent types of these machines, there are two hammers, both driven by compressed air. One operates horizontally and the other vertically. It is said that a machine of one of these types requires only  $1\frac{1}{2}$

minutes to form a bit, and a record of re-pointing worn drills at the rate of one in a little less than a minute has been made by it. Hand drills, may, it seems, be sharpened by machines, provided suitable dies are used.

Where high speed tool steel is employed in high-duty drilling machines, it is convenient, not to say necessary, to have a special furnace

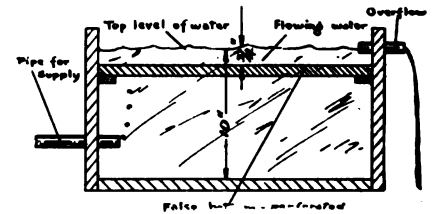

**FIG. 11 — LONGITUDINAL SECTION THROUGH QUENCHING BATH FOR ROCK DRILLS**

in which to do the heating for welding and for hardening high speed drill steel. One type of special furnace burns oil and operates with an air supply under pressure. Petroleum, gasoline, kerosene or distillate may be used. When the fuel is, as in this case, in the form of oil, it is possible to get a high temperature quickly and to maintain it at or near a desired level. The burner employed may be either one requiring high-pressure air or one requiring low-pressure air. With a high-pressure burner, the air may have a tension as high as 50 or 100 pounds per square inch or even more. Naturally, this air must come from a compressor. The low-pressure burner may demand air with a tension of only a moderate number of ounces per square inch—say 12 to 40. This air may come from any standard blower which is of the positive pressure type. A great advantage of such a furnace—an advantage that will appeal to the smith—is the fact that, with oil as a fuel, there are no ashes and the like to clear away. Naturally, the smith will have to learn how to control the burner to get the best results. But this will not be unusually difficult for a man who is otherwise capable of hardening and welding the high speed steel.

Where the ordinary carbon drill steel is employed, the coke and coal furnace will do the work very well. In one design, the drill steel is in view all the time. The oil furnace just referred to is similarly designed. This is a matter of some importance, as otherwise there might be danger of burning the steel. Steel actually *burnt* is useless for drilling purposes, and should be at once put on the scrap heap. Indeed, one should, especially with the ordinary carbon tool steel, be on the lookout lest the steel be even overheated. While overheated steel is not worth-

less, being usually capable of more or less complete restoration, still the restoration of overheated steel to its original quality and strength takes time and labor. The coal and coke furnace under consideration may be used with coke or with hard coal. It consists of a box-like receptacle which is lined with fire brick. This forge has a metal arch. This also is lined with the brick. The ash box is naturally separated from the fire chamber by a grate. Compressed air is introduced into the ash box and passes up through the grate and bed of coals. This is a kind of forced draft. It is regulated by means of a suitable valve. A lever controls the sections of the grate, accomplishing either shaking or dumping as may be desired. This forge may be operated with an approach to continuity by keeping the complement of steels full all the time. Whenever a bar is removed, another may be put in its place. The capacity of the forge is thus kept at a maximum. With one of these forges, it is claimed in effect that from 44 to 62 bits may be heated every hour. Its floor space is only 25 x 34½ inches and its height 55, so that it is not a big affair, despite its capacity. There are two grates, each 4½ by 18 inches. Consequently, there is an opening 18 inches wide and a fire 9 inches deep.

to hear blacksmiths talk through its columns from one state to another and back again, and a source of much good information. RALPH HABEMAN, Kansas.

**Speaking of Vacations**—This is my first contribution to these columns. I own a shop 100 ft. long; 27 ft. wide, cement block and cement floor, electric power, and a good set of tools. I do all the work alone. For six years I haven't had a week off and it occurs to me that there must be a lot of others in the same position. If the American Blacksmith or some of

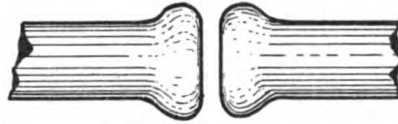

Upset and square ends when welding in the forge-fire.



Grind ends to a 90° angle when oxy-acetylene welding.

us smiths could find a few good men who could be trusted to run our shops for a week or two, it seems to me that it would be a mighty fine thing. This of course is meant to interest the one man shop where the owner is tied down all the time.

I would like to hear from other smiths through these columns what they think of a plan like this.

HANS BECK, Iowa.

**A Successful Mixed Business in British Columbia**—My line of business consists of side lines only. There are only about forty horses in this town, and what few automobiles there are, are known as Fords, and repair parts for them can be bought quicker and cheaper than a blacksmith could make them up himself.

There is just one other blacksmith shop in town and the owner hasn't much to do himself, so naturally I have had to look around for new lines of business. My line of work is repairing stoves, ranges, furnaces, bicycles, guns, phonographs, and trunks; and key making. I also do some boat work and handle implements and tools for mining for which there is a good demand in the surrounding country. I also do wood work, painting and a great deal of pipe work and awning repairing.

Prices are very good, only it is hard to get good men. I employ from one to six men, as the occasion requires.

Just a few words about "Advertising." I find in my line of business that an "Ad" amongst the news brings very gratifying results. A good calendar, not a cheap one, is worth every cent of the money invested. If you do out-of-town business, newspapers are preferable. The best advertisement of all though is good work, and without good work to back up what you say all other advertising is worthless.

My shop is in a building 50 x 25, with a big basement. I have a complete blacksmith outfit, a woodworking, pipe-fitting, and paint shop; also a five horse power electric motor. I haven't a picture of my shop at present but will send one in later. Perhaps some of my brother blacksmiths in the States will recognize me, and write to me.

Here is a new way to repair a leak in a hot water tank. Instead of drilling the hole bigger as is generally done, take a tapering punch and drive it into the hole with light blows. The object of this is to thicken the iron. Then take a tap and cut a thread into the hole, and screw a block into same. Cut the projecting part of the block off, and solder it over. You can be sure that it will never leak at the same place again if done properly.

Fred Schulze, "Fritz the Handy Man," British Columbia.

**Two Queries on How to Weld a Cultivator Axle**—I would like to know how to weld a cultivator axle. I have welded a good many and never had good luck yet. It seems to me that they are hard steel. I would also like to know about automobile axles, how to weld them. Will you kindly answer me these two questions.

A. L. Benesh, S. Dakota.

I have just tried to weld a cultivator axle and it would not unite at all. These axles are cold-rolled steel. Could you give me any information on welding cold roll shafts and axles? Any information will be appreciated.

A. S. Lanham, Illinois.

**In Reply:**—Cultivator and automobile axles are of cold-rolled steel and to weld in the forge fire proceed as follows:

Upset the two broken ends and leave them square as in the accompanying diagram and place in the fire with the ends near each other. Heat to bright red and cover with borax and again heat so that ends are nearly ready to fuse (welding heat) and with ends together in the fire drive the two together. It may be necessary to have the helper hold a heavy hammer on the end of one piece while you drive the other against it.

When thoroughly welded, hammer down to size and you have a good job.

To weld with the Oxy-Acetylene flame proceed as follows:

Grind the two ends so that the centers will touch. Place on fire-brick so shafts will be straight; being careful to secure them so they cannot roll or move.

We will assume that the welding outfit is assembled ready for business.

If we have a ¾" shaft to weld we will use a number six size tip, screwing it into the torch with just enough force so it will not leak.

Light the torch and adjust the cone as long as possible and still have a distinct, round end cone—without the slightest show of a ragged end.

This will be a neutral flame. Proceed to heat the two ends to be welded until they begin to flow together, and then put the end of an ⅛" soft iron wire into the weld and by careful handling of torch and wire, the opening will gradually fill. Turn the shaft and fill the other side, being sure that the ends of shaft are fused (melted) before adding the filling wire. The filling should be done as rapidly as possible as too long an application of the torch will burn the steel.

The shaft should be built up larger than the finished shaft and while hot remove the scale and lightly hammer to size.

Cold rolled steel is not difficult to handle and do good work, but tool or other carbon steels must be welded very carefully, and only enough heat used to fuse (melt) and fill and then remove the torch. In welding "cold rolled" don't mistake a sweating surface for a fused surface. The metal must be liquid enough to flow.

S. S., New York.

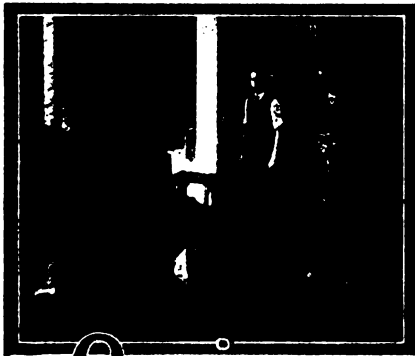

## Queries—Answers—Notes

Who wrote for these books? Sometime ago a letter was received by our Subscribers' Service Department requesting instruction booklets on the care and operation of various models of the Overland automobile. We have received copies pertaining to Models 85-B, 75-B, 75, and 85. Will the reader who requested these please write in and give us his address that we may forward them to him? This letter was unfortunately mislaid.

S. S., New York.

**From a Kansas Subscriber**—I will gladly subscribe again, as I am a live wire and cannot do without the American Blacksmith journal. It is very interesting to me



## Index to Vol. 16

Advertising: It Pays to Buy an Advertised Article .....	193	to Clean .....	22	Business: A Modern Blacksmith Shop	55
Advertising: A Sample of Smith Shop Advertising .....	141	Automobile: Salvaging a Wrecked Auto .....	161	Business: A Sample of Smith Shop Advertisement .....	141
Advertising: An Advertising Poster .....	292	Automobile: Repairing Clutch and Gear-Set Troubles .....	101	Business: Buying Against Rising Costs .....	140
Advertising: An Example of Progressive Smith Shop Advertising .....	294	Automobile: To Correct Noisy Gears in a Ford .....	154	Business: Cutting Prices—Poem .....	300
Advertising: A Successful Business Getting Letter .....	293	Automobile: To Correct Squeaking Springs .....	179	Business: Half a Century in the Smithing Business .....	295
Aluminum Cleaning Hint .....	74	Automobile: Painting and Finishing the Automobile .....	97	Business: Character in Business ..	255
Aluminum, To Solder .....	204	Automobile: Wiring Diagram, Model T Ford .....	23	Business: Watch Your Contracts for These Clauses .....	213
Aluminum, To Turn .....	179	Axe Dressing, Hardening and Tempering .....	47	Business: Cutting out the Guess Work	107
Ankle Hitter, Shoeing The .....	10	Axle: How to Weld a Cultivator ..	309	Business: Federal Trade Commission and Cost Accounting .....	59
Anvil, A Noiseless .....	179	Axle: Assembling Light Car Rear Axle .....	130	Business: Figuring Costs .....	204
Automobile: A Pacific Coast Auto Shop .....	138	Axle Spindles, Axle Boxes, Standard Specifications of .....	37	Business: How I Built up My Shoeing Business .....	30-31
Automobile: A Simple Oil Filter .....	101	Axle, To Set Properly .....	62	Business: It Pays to Buy an Advertised Article .....	193
Automobile: Assembling Light Car Rear Axle .....	130	Axles, To Repair Broken Pipe .....	205	Business: On Handling Competitors ..	205
Automobile: A Western New York Auto Shop .....	237	Axes: Hardening, Dressing and Tempering .....	47	Business: Price Cutting .....	206
Automobile: Auto Wheel Channels, To Tighten .....	22	Batteries, To Make Home-Made .....	231	Business: Rules for Figuring Costs and Profits .....	108
Automobile: Castor Oil for Brakes ..	204	Bending Brass and Copper Tubing ..	152	Business: Shoeing Prices vs. General Smithing Prices .....	169
Automobile: Causes of Noisy Engine Action .....	75	Bending Steel Bars .....	276	Business: System in Buying and Selling .....	293
Automobile: Common Sense Methods in Curing Auto Troubles .....	159-206-232	Blacksmith Honored by Kings .....	214	Business: Stop the Leaks .....	240
Automobile: Converting a Horse Drawn Harse Body to Fit an Automobile Chassis .....	51	Blacksmith, An Illinois .....	21	Business: The Cost System Used in a Big Pacific Coast Shop .....	296
Automobile: Cooling and Lubrication Trouble .....	24	Blacksmith Shop and Garage, A Modern .....	55	Business: When Purchasing Goods ..	298
Automobile: A Cracked Water Jacket and Repair .....	75	Blacksmith, A Veteran .....	36	Calculating Stock .....	58-100-231-271
Automobile: Curing Engine Misfiring at High Speeds .....	156	Bolts: Estimating Stock for Bolt Heads .....	270	Canvas: A Paint for .....	152
Automobile: How Motor Truck is Aiding Blacksmith .....	163	Brass, A Polish for .....	22	Canvas, A Paint for .....	152
Automobile: Motor Knocks and How to Remedy .....	155-257	Brass-Polishing Compound, A .....	230	Case for Screws, Bolts, etc. Handy ..	74
Automobile: Painting the Automobile	50	Brick: A Cement for Fire Bricks ..	74	Case Hardening, Information on .....	154
Automobile: Practical Auto Repair Hints .....	129	Bricks, Cement for Fire .....	74	Case Hardening Recipe, A .....	98
Automobile: Practical Method of Turning Brake Drums .....	130	Bronchos, Unique Method of Shoeing ..	186	Case-Harden, Steel .....	22
Automobile: Practical Points for the Automobile Painter .....	70	Brushes: Care of .....	204	Case-Hardening, The Depreciation of the Packing Material used in .....	42
Automobile: To Clean Scale Deposits in Radiator .....	230	Browning Gun Barrels .....	154-231	Cast Iron, To File with Wood Rasps ..	22
Automobile: Radiator of Automobile,		Business: A Few Observations Concerning Side Lines .....	294	Cast Iron with Ordinary Saw, To Cut	22
		Business: Building a Successful Manufacturing Business from a Small Blacksmith Shop .....	289	Cast Iron, Cutting Properties of High Speed Steel on .....	120
		Business, How I Built up My Shoeing .....	30-31	Castings, A Blow-Hole Filler for .....	152
		Business Men Who Wait for Legal Advice .....	192	Castings, When Drilling or Filing Hard .....	128
				Cement for Fire Bricks .....	74
				Cement, A Heat-Proof and Water Proof .....	128



Cement for Holding Tools ..... 73  
 Cement, An Iron ..... 99  
 Cement for Steam and Water Pipes. 204  
 Cement, An Iron ..... 230  
 Cement for Marble ..... 22  
 Character In Business ..... 255  
 Circumference? What's the ..... 229  
 Cleaning Hint, Aluminum ..... 74  
 Clutch and Gear-Set Troubles, Repairing ..... 101  
 Coal in a Pile? How Many Tons of... 142  
 Cold Chisel, Tempering A ..... 74  
 Competitors: On Handling Them. 205  
 Common Sense Methods in Curing Auto Troubles ..... 159-206-232  
 Contraction of Sheet Metal ..... 58  
 Contracts, Watch Yours for These Clauses ..... 213  
 Contracted Feet, Shoeing the Horse For ..... 188  
 Converting a Horse Drawn Hearse Body to Fit an Automobile Chassis 51  
 Copper, Coloring ..... 152  
 Copper, Soldering ..... 283  
 Cost Accounting, Federal Trade Commission ..... 59  
 Costs, Buying Against Rising ..... 140  
 Costs: Cost System in a Pacific Coast Shop ..... 296  
 Costs: How one Smith Met the Situation ..... 295  
 Costs, Figuring ..... 204  
 Costs and Profits, Rules for Figuring 108  
 Cracks in Fine Tools, To Detect..... 281  
 Cracked Water Jacket and Repair... 75  
 Crucible, A Clay Pipe ..... 178  
 Cruise of an Anvil Pounder ..... 297  
 Cutting out the Guess Work ..... 107  
 Cutting Prices ..... 206  
 Cutting Prices—Poem ..... 300  
 Cutting Iron with Ordinary Saw..... 22  
 Drill Feed, An Improvement ..... 22-23  
 Dropped Sole, Shoeing the Horse for. 167  
 Electric Furnace, A Non-Oxidizing. 3  
 Emery Wheel, To Balance an ..... 74  
 Engine Base, Repairing a Crack in... 205  
 Estimating Size Stock Required for Bolt Heads ..... 270  
 File Cut, To Make an Old ..... 179  
 Filing Hard Castings, When Drilling or ..... 128  
 File, How to File Hand Saws..... 61  
 Fire Insurance, Don't Place With Anybody You Don't Know..... 39  
 Fire, Who Must Stand the Loss of This? ..... 110  
 Fireproof Work, To ..... 128  
 Filter, A Simple Oil ..... 101  
 Forge Repair, A ..... 153  
 Forging or Over Reaching, Remedy for Forges, Shoeing the Horse that..... 84  
 Forging, To Stop a Horse from..... 180  
 Furnace, A Non-Oxidizing Electric... 3  
 Furnaces for the Amateur Founder, Melting ..... 71  
 Gate, An 18th Century Wrought Iron 62  
 Gateway, Wrought Iron ..... 86  
 Gas Engine Bearings ..... 128  
 Gas Engine Operation Made Simple ..... 18-72-87-113-149  
 Hammer Handles Stay on, To Make 90  
 Hammer, Power: Put the Power Hammer to Work..... 211-242-269  
 Hardening: A Case Hardening Recipe 98  
 Hardening, Dressing and Tempering Axes ..... 47  
 Hardening: Information on Case Hardening ..... 154  
 Hardening Mill Picks, A Solution for 99  
 Hardening, Notes on the Theory and Practice of ..... 46-59  
 Hardening: The Depreciation of

Packing Material Used in Case Hardening Steel..... 42  
 Hardening: To Case Harden Steel.. 22  
 Hardening Springs, Notes on Theory and Practice of ..... 124  
 Hardening High Speed Steel Tools in Water ..... 180  
 Horse—A Spring Circular, The ..... 228  
 Horses in the War, American..... 258  
 Horse, Movement of the ..... 82  
 Horse—Organize to Care for Army Animals, The ..... 255  
 Horseless Farm Not Yet a Reality 30  
 Horseless Age Long Way in Future, A 189  
 Horses, Hot Weather Rules for ..... 260  
 Horseshoe for Luck, A..... 151  
 Horseshoeing: Lameness and Shoeing 62  
 Horseshoeing: Laminitis and How to Shoe the Laminitic Foot ..... 29  
 Horseshoeing: Levelling the Horse's Feet ..... 185  
 Horseshoeing: Navicular Disease..... 32  
 Horseshoeing: Remedy for Forging or Over-Reaching ..... 205  
 Horseshoeing: Ring Bone and Side Bone ..... 266  
 Horseshoeing: Sand Cracks ..... 188  
 Horseshoeing: Several Questions and Answers on Shoeing ..... 82  
 Horseshoeing: Shoeing the Ankle Hitter ..... 10  
 Horseshoeing: Shoeing for Buckled Joints ..... 215  
 Horseshoeing: Shoeing the Horse for Contracted Feet ..... 188  
 Horseshoeing: Shoeing the Horse for Dropped Sole ..... 167  
 Horseshoeing: Shoeing for Horse that Forges ..... 84  
 Horseshoeing: Shoeing for Quarter Cracks ..... 113  
 Horseshoeing: Some Cures and Remedies by Shoeing ..... 263  
 Horseshoeing: The 3 types of Horse's Feet and How They are Shod..... 111  
 Horseshoeing: To Stop a Horse from Forging ..... 180  
 Horseshoeing: Treatment of Navicular Disease by Shoeing ..... 81  
 Horseshoeing: Treatment of Seedy-Toe ..... 230  
 Horseshoeing: Unique Method of Shoeing Bronchos ..... 186  
 Hot Weather Rules for Horses..... 260  
 How to Weld a Cultivator Axle: ..... 309  
 Iron: An 18th Century Wrought Iron Gate ..... 62  
 Iron: A Wrought Iron Gateway..... 86  
 Iron Cement, An ..... 99  
 Iron Cement, An ..... 230  
 Iron: Cutting Properties of High Iron or Steel—Which? ..... 256  
 Is Retreading of Tires Successful?... 153  
 Iron: To Cut Cast Iron..... 22  
 Iron: To File Cast Iron..... 22  
 Iron: Speed Steel on Cast ..... 120  
 Lameness and Shoeing ..... 62  
 Laminitis and How to Shoe for..... 29  
 Lathe Practice, Fundamentals of..... 16-68-146-172-198-224-251  
 Law: Business Men Who Wait Until Afterward for Legal Advice..... 192  
 Law: Cancelling a Sales Contract ... 85  
 Law: Don't Place Fire Insurance with Anybody You don't know about... 30  
 Law: Penalty for Speaking Falsely of a Business Man ..... 56  
 Law: Points to Watch When You Hire a Broker to Sell..... 137  
 Law: Some Suggestions for Discontented Partners ..... 9  
 Law: Watch your Contracts or Order Blanks for These Clauses..... 213  
 Law: When Purchasing Goods..... 298

Law: Who Must Stand the Loss of This Fire? ..... 110  
 Lead From Sticking, To Prevent Hot 230  
 Leaks, Metal Dough for Small ..... 230  
 Levelling the Horse's Feet ..... 185  
 Lubrication and Cooling Troubles... 24  
 Lubricants for Machine Work ..... 179  
 Lubricant for Woodworking, A..... 128  
 Lubricating Oil for Cold Weather... 99  
 Machine Work, Lubricants for..... 179  
 Marble, Cement for ..... 22  
 Metal Dough for Small Leaks..... 230  
 Mirrors and Silver Plating Glass, Silvering ..... 153  
 Misfiring at High Speeds, Curing Engine ..... 156  
 Motor Knocks and How to Remedy 155-257  
 Motor Truck is Aiding Farmer and Blacksmith, How ..... 163  
 Navicular Disease ..... 32  
 Navicular Disease, Treatment of ... 81  
 Noisy Engine Action, Causes of..... 75  
 Noisy Gears in a Ford, To Correct... 154  
 Oil Filter for the Auto Shop, A Simple 101  
 Oil for Brakes, Castor ..... 204  
 Oil for Cold Weather, Lubricating... 99  
 Oil Stone Sharp, To Keep ..... 179  
 Oil Stones, To True-Up..... 99  
 Oil: To Remove ..... 282  
 Oxy-Acetylene: An Oxy-Acetylene Welding Job With a Profit..... 85  
 Oxy-Acetylene: Contraction of Sheet Metal When Oxy-Acetylene Welded 58  
 Oxy-Acetylene: Oxy-Acetylene Welding Hints ..... 115-136  
 Oxy-Acetylene: The Oxy-Acetylene Plant ..... 133-174-199-216-244-280  
 Painting a Blackboard..... 128  
 Painting the Automobile Quickly and Cheaply ..... 50  
 Paint, Care of Brushes ..... 204  
 Paint for Canvas, A..... 162  
 Painting: Practical Points for the Automobile Painter..... 70  
 Paint Remover ..... 74  
 Paint, Removing from Wood..... 179  
 Paint Remover, A ..... 99  
 Painting: Striping Pigments ..... 35  
 Paint, To Remove Old Oil, or Varnish 282  
 Painting: Ways and Means of..... 97  
 Partners, Some Suggestions for Discontented ..... 9  
 Pipe Hangers, To Figure Stock for.. 231  
 Plow and Tractor Construction and Adjustments ..... 48  
 Plow Point, Welding A..... 181  
 Plow-Share, To Temper A ..... 73  
 Plow, A Combination ..... 99  
 Polishing Compound, A Brass ..... 230  
 Polish for Brass ..... 22  
 Power Hammer to Work, Put The... 211-242-269  
 Practical Auto Repair Hints ..... 120  
 Price Cutting ..... 206  
 Price Lists 75-90-100-108-150-177-257-282  
 Pulley Calculation, Chart for Quick.. 58  
 Pull Rusty Spike From Wood, To... 204  
 Purchasing Goods, When..... 298  
 Putty, To Make Hard ..... 73  
 Questions and Answers on Shoeing.. 82  
 Quarter Cracks, Shoeing for ..... 113  
 Radiator of Automobile, How to Clean ..... 22-230  
 Recutting Horse Rasps ..... 154  
 Removing Old Oil, Paint or Varnish. 282  
 Repairing a Crack in Engine Base... 205  
 Ring Bone and Side Bone..... 266  
 Rock Drills ..... 302  
 Rust Mixture, An Anti ..... 98  
 Rust, To Remove ..... 128





Sales Contract, Cancelling A.....	85	Shoering Prices vs. General Smithing		Tempering a Cold Chisel .....	74
Salvaging a Wrecked Automobile....	161	Silvering Mirrors .....	153	Temper in Small Taps and Reamers,	
Saws, Tempering Composition .....	128	Prices .....	169	Drawing the .....	180
Sand Cracks .....	188	Shop: A Modern Shop and Garage. 55		Tempering, Hardening and Dressing	
Screw Extractor .....	128	Shop and Its Efficient System, A Pro-		Axes .....	47
Seedy-Toe, Treatment of .....	230	gressive Nebraska .....	241	Three Types of Horse's Feet and How	
Sell, Points to Watch When You Hire		Shop, A Big Pacific Coast Auto....	138	Shod, The .....	111
a Broker to .....	137	Shop, A Western N. Y. Auto.....	237	Tire Bender, Handy .....	282
Shoering: How I Built up my Shoer-		Shop Plans .....	256-257-258	Tires, Care of .....	163-201-219-258-284
ing Business .....	30	Shoering Smiths of the War, British..	11	Tires, To Plug Small Holes in .....	153
Shoering: Lameness and Shoering .....	62	Side Bone .....	266	Tires: Is Retreading Successful?..	153
Shoering: Laminitis and How to Shoe		Side Lines: A Few Observations Con-		Tool—Ezy-Out Screw Extractor A	
the Laminitic Foot .....	29	cerning Them .....	294	New .....	128
Shoering: Levelling the Horse's Feet .	185	Smith in the Daily News .....	13-273	Tools, Cement for Holding .....	73
Shoering: Navicular Disease .....	32	Smith Work on a Whaling Ship....	20	Tool Post and the Cutting Tool, The	95
Shoering: Remedy for Forging or Over-		Solder Aluminum, To .....	204	Tools, Whaling .....	99
Reaching .....	205	Some Remedies by Shoering .....	263	Tractor and Plow Construction and	
Shoering: Ring Bone and Side Bone..	266	Spring Circular on the Horse, A....	228	Adjustments .....	48
Shoering: Sand Cracks .....	188	Speaking Falsely of a Business Man,		Unique Method of Shoering Bronchos.	186
Shoering: Several Questions and Ans-		Penalty for .....	56	Vacations .....	309
wers on Shoering .....	82	Springs, Notes on Theory and Prac-		Varnish Adhere to Metal, To Make..	152
Shoering: Shoering the Ankle Hitter... 10		tice of Hardening .....	124	Varnish: To Remove .....	282
Shoering: Shoering for Buckled Joints.. 215		Spring, To Correct Squeaking.....	179	Welding a Plow Point .....	181
Shoering: Shoering the Horse for Con-		Springs, To Temper Coil .....	22	Welding Compounds .....	22-47-256-283
tracted Feet .....	188	Spring Steel, Welding .....	99	Welding in Cast Iron Cogs.....	154-205
Shoering: Shoering the Horse for Drop-		Spring Steel, Welding .....	282	Weldless Rings, How to Calculate the	
ped Sole .....	167	Spurs, Information on Making.....	153	Amount of Stock Needed for Forg-	
Shoering: Shoering the Horse that		Spurs, Forging .....	74	ing .....	271
Forges .....	84	Steel: Bending Steel Bars.....	276	Welding Pipe in a Tunnel .....	257
Shoering: Shoering for Quarter Cracks	113	Steel, Case-Harden .....	22	Welding Spring Steel .....	282
Shoering: Some Cures and Remedies		Steel, High-Speed Steel? Is Tungsten	231	Welding Spring Steel .....	99
by Shoering .....	263	Steel or Iron—Which? .....	256	Welding Steel .....	74
Shoering: The 3 Types of Horse's Feet		Steel on Cast Iron, Cutting Properties		Welding Wide Stock .....	100-129-154
and How They are Shod .....	111	of High Speed .....	120	Whaling Ship, Smith Work on .....	20
Shoering: To Stop a Horse From Forg-		Steel, When Working .....	128	Wheel Channels, To Tighten Auto... 22	
ing .....	180	Steel, Welding Spring .....	99	Wheel Dished? Why is a .....	116
Shoering: Treatment of Navicular Dis-		Steel, Welding .....	74	Wheel Hubs and Flanges, Standard	
ease by Shoering .....	81	Stock, Calculating .....	58-100-231-271	Specifications of .....	37
Shoering: Treatment of Seedy-Toe... 230		Stop the Leaks .....	240	Wheel, To Balance an Emery .....	74
Shoering: Unique Method of Shoering		Steel Tools in Water, Hardens High		When is a Man Too Old for Useful	
Bronchos .....	186	Speed .....	180	Work? .....	272
		System in Buying and Selling.....	293	Whitewash, A Recipe for .....	179
		Tanks, Handy Chart for Finding Vol-		Wiring Diagram, Model T Ford.....	23
		ume of .....	127	Woodworking, A Lubricant for .....	128
		Temper a Plow-Share, To .....	73	Wrought Iron Gates .....	34-62-86
		Temper Coil Springs, To .....	22		
		Tempering Composition for Saws ...	128		

# End of Vol. 16

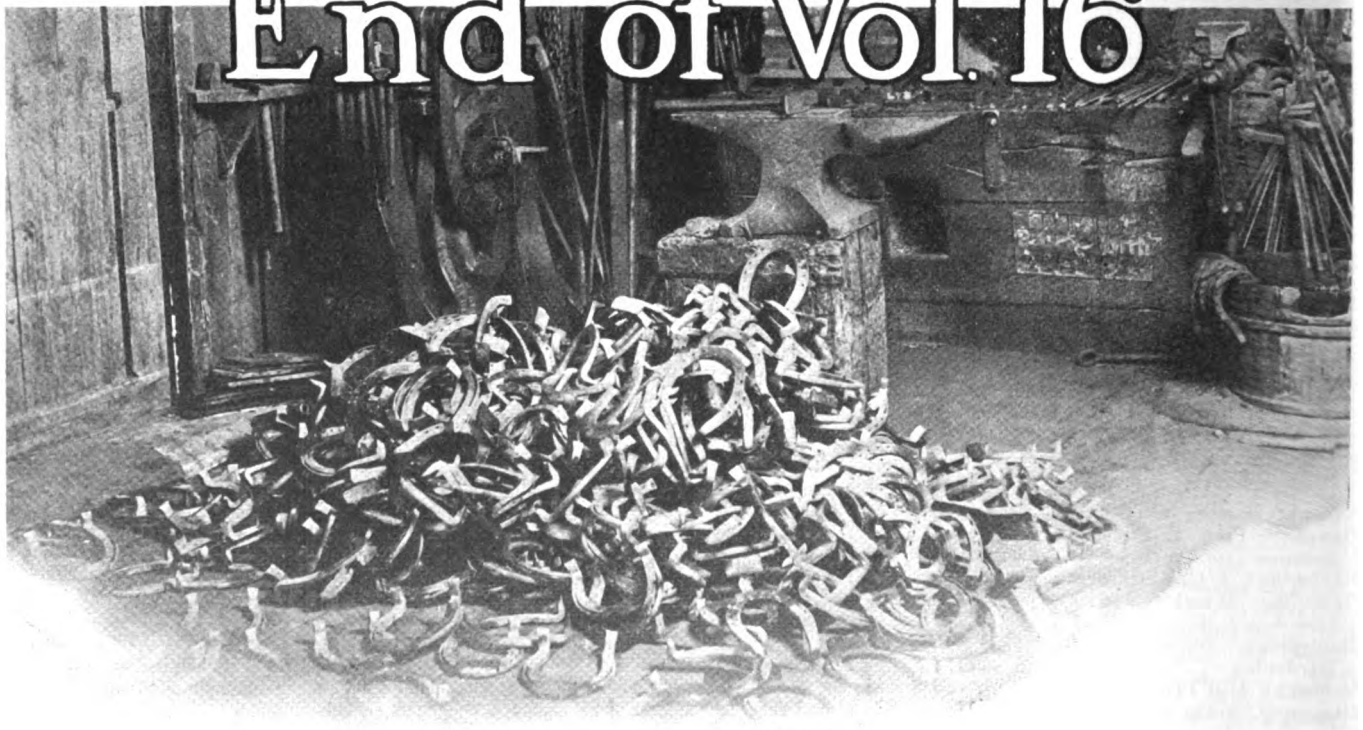

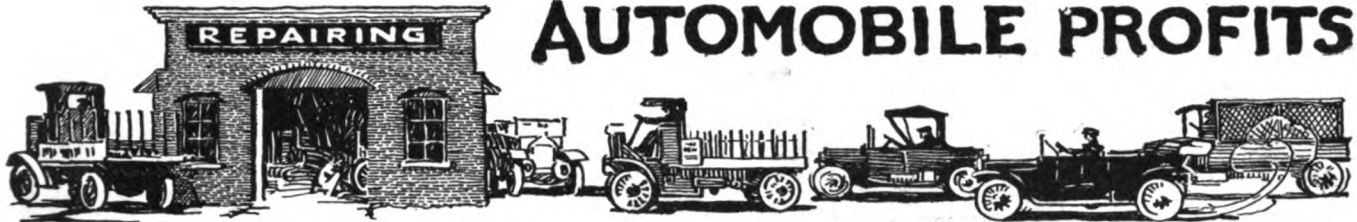

# AUTOMOBILE PROFITS

**T**HERE are big opportunities in the automobile repair field for the general smith. If you want to make the best of these big opportunities read this department every month.—It contains the announcements of advertisers who have real automobile profit suggestions. Look here for your equipment, supplies and accessories.—Turn to this department for ideas, suggestions and hints. It means more money for you—more Automobile Profits.

WHEN IN DOUBT ASK SUBSCRIBER'S SERVICE

## Automobile Tops to Fit Any Car

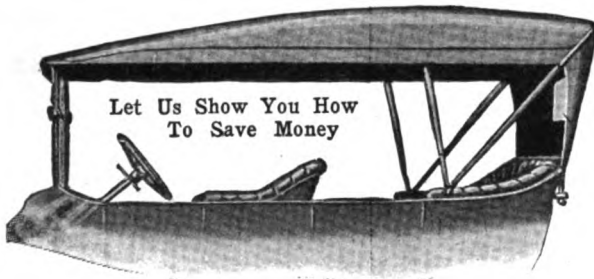

Let Us Show You How To Save Money

- Auto Tops, - - \$12.50 and Up.
- Top Covers, - - 4.75 and Up.
- Seat Covers, - - - 3.15 and Up.
- Ford Curtains, - - 4.10 and Up.

**BUOB & SCHEU, 50 E. Court Street, CINCINNATI, OHIO**

## A Power Hammer Built by Men Who Know How

When you buy a Power Hammer be sure of its strength—durability and simplicity. Be sure it will handle the work claimed. You can be absolutely sure by buying a Mayer Hammer, built by men with twenty-five years hammer experience.

### Strong, Durable and Efficient

Fewer working parts than any other hammer built—only the best materials used—ease of operation—are features of Mayer Hammers.

Your supply house will tell you about the Mayer Hammer — If not, write us for full information and prices. Built in 25, 50 and 100 lb. sizes.

**Mayer Brothers, Antigo, :: Wisconsin**



## CAPTURE THE BIG MONEY IN AUTO REPAIRING

### MAKE SURE YOUR PREPARATION IS RIGHT

If you would make a real, lasting success of automobile work—if you would make your shop the leading auto fixing place in town—then come to the Greer School and get the right steer by actual first-hand methods. You have the general mechanical ability to learn in only a few weeks. But unless you are grounded with the right knowledge you will never be a first class Auto Smith.

Let us tell you about our great success—our 12 years experience in fitting men for the automobile game—and how our personal method of expert instruction gives you a grasp of the whole proposition you can obtain in no other way. Write for complete details at once.

**THE GREER COLLEGE OF MOTORING**  
Greer Bldg.,  
1519-1521 Wabash Ave.,  
Chicago, Ill.



## Welding Machines

### For Cold Weather

Cold weather brings cracked auto cylinders to the welder for repairs. Prepare for this profitable work by getting a Vulcan Junior welder. It automatically generates its acetylene and has anti-freeze features for the cold unheated shop.

Send for Catalogue A 4. It is of special interest to you.



**VULCAN PROCESS CO.,**  
2424 University Avenue S. E.

**Minneapolis, Minn.**



# Why Wouldn't a "Little Giant" Threading Machine

## Help in YOUR SHOP?

No matter whether you have little or much threading work—there is a Little Giant Machine to fit your needs—from the little



No. 6 Machine (bench)

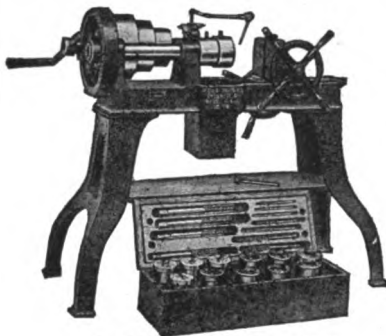

No. 10 Machine (hand or power)

hand bench machine to the big, powerful power machine with automatic opening dies. Catalog No. 34 shows the machines as well as the complete line of taps, dies, screw plates, reamers, etc.

### GREENFIELD TAP AND DIE CORPORATION

Wells Brothers Company Division, GREENFIELD, MASS.  
New York, 28 Warren St.; Chicago, 13 So. Clinton St.; Philadelphia, 38 No. Sixth St.; Detroit, 55-57-59 Wayne St.  
In Canada, Wells Brothers Co. of Canada, Ltd., Galt, Ontario.

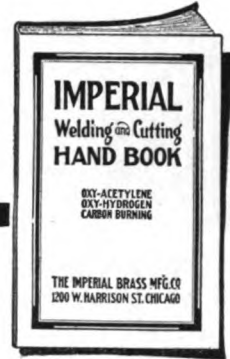

# Every Blacksmith

Has been looking for The Imperial Handbook of Welding, Cutting, and Decarbonizing.

It contains 60 pages, 40 illustrations—compact—brief—written so every one can understand.

No tedious history of the process, no long involved technical explanation of the chemical and physical action of the gases—just plain, simple directions—all the things every welder must know and understand to make a success.

Imperial Welding and Cutting Equipment has proved to be the safest, most efficient and most economical, and now we offer the best welding instructions ever issued—free to users of Imperial Apparatus—\$1.00 each to those less fortunate.

The edition is limited—act now to be sure of your copy—also ask for catalog and prices of Imperial Equipment.

## Imperial Brass Mfg. Co.

1220 W. Harrison St., CHICAGO.



## TRY BORAX-ETTE

For Welding Toe-Calks.

THEY WON'T KNOCK OFF

It Makes Steel Weld Like Iron. It Has No Equal for Welding Tires, Axles and Springs.

PREPARED ESPECIALLY FOR WELDING FAR SUPERIOR TO COMMON BORAX.

FOR SALE BY ALL DEALERS. SAMPLES FREE.

## Cortland Welding Compound Co.

CORTLAND, N. Y.

### NEW BOOKS.

**Dyke's Automobile and Gasoline Engine Encyclopedia**—by A. L. Dyke, E. E. 832 Pages—6 3/4 x 9 3/4—2,370 Illustrations—Cloth—Price, \$3.00 (12/6).

This is the fifth edition of this very complete work on the automobile. It covers the subject of the motor vehicle for the repairman, the garage man, the owner, the driver, the salesman and the prospective purchaser. It explains the auto from radiator cap to tail light and from top to tires. It covers the car on the road, in the street, in the garage and in the shop. The volume presents to the reader practically every detail of the motor vehicle that he will ever want to know.

Details of the mechanism are explained—the various drives, the steering arrangement, brakes, springs, axles, clutches and

every part of the motor, the chassis, body and top and tires are detailed fully. The late developments in the motor vehicle field are also explained, and three supplements on the Ford, the Packard and the King are included.

Perhaps the most interesting and valuable sections of the volume for the auto-smith are the chapters on repairing, the repair shop and its equipment, and the repair shop hints.

These chapters with the others on the details of automobile construction make the volume a most practical and valuable reference book and handy guide for the practical automobile repairman.

**Questions and Answers on Automobile Design, Construction and Repair**, by Victor W. Pagé, 650 pages—350 illustrations and plates. Cloth, \$1.50 or 6/6. Norman Hen-

ley Publishing Company.

The 1916 edition of this excellent book has just been published. Like the original book it answers the questions asked by the automobile owner, operator and repairman, and includes the Developments in the 1916 Automobiles. The questions and answers cover all parts of the modern automobile from radiator to tail light and from top to tires. The modern lighting and starting systems are explained by Mr. Pagé in his plain, understandable manner for which he seems to have exceptional faculty.

Troubles and repairs for all parts of the automobile are made plain and the automobile repairman will find this entire book just heapingful of sound, practical information on the motor vehicle.

(Continued on page 46.)

# Makes Money For You!!!

BLACKSMITHS and repairmen find MECO Welding Apparatus increases their profits by enabling them to do better work—and all kinds of welding and cutting jobs. MECO Torch works perfectly as either a cutter or welder.

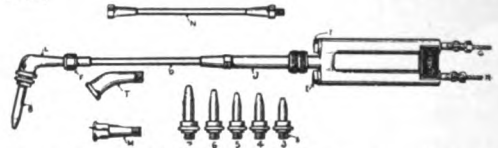

Figure—illustrates MECO Type C. torch arranged for welding. Acetylene and oxygen hoses are attached to union connections H. & G, respectively. Different angle heads, T. L. & M., are attached with union nut F. To make torch longer, attach extension N. between members O. & T. Write for information about MECO Welding Apparatus and MECO Carbon Remover (900% profit in removing carbon from auto cylinders). Write today to MODERN ENGINEERING COMPANY, 1405 St. Charles St., St. Louis, Mo.

## MECO Acetylene Welding Apparatus



Get the New

# Little Giant

TRADE MARK REG.

## CATALOGUE.

We have just issued a New Catalogue which completely describes our full line of Punches and Shears.

Write for it AT ONCE.



*It will pay you to look it over before buying.*

**Little Giant Punch & Shear Co.**  
210 S. Market St. SPARTA, ILL.



## Smartness: Quality

**M**ORE and more vehicle owners are coming to appreciate the importance of the right tire equipment.

To protect the vehicle; to lend comfort and style to the rig.

# Firestone Carriage Tires

have had a wide influence in the field—because of pioneer leadership in every vital improvement.

Long, resilient wear and elegant appearance are among the recognized benefits of Firestone service.

**DEALERS**—you benefit by this accepted place of Firestone. You benefit also by the Firestone selling helps that come to you *free*. Write for details.

**FIRESTONE TIRE AND RUBBER CO.**  
"America's Largest Exclusive Tire and Rim Makers"  
Akron, Ohio—Branches and Dealers Everywhere

## Find Out What Great Profits a Crescent Woodworker Would Make for You

Have you ever seriously considered the extra business you could handle if you had a Crescent Woodworker.

For instance this is the automobile time of the year—if you had a Crescent that would mean many chances to build new bodies or to convert old cars into motor trucks.

This is also the time when farmers are ready to buy hay racks, carts, farm wagons, plow handles, and many other articles you could make in your spare time at good profits if you had the help of a Crescent.

Let us tell you about this special design which has been developed solely for the Blacksmith-Carriage shop. Let us explain our system of attachments whereby you are furnished with only the essential machines at the beginning and can select your attachments as you are sure you need them.

This is information you would be glad to receive—and you would also find the 1916 Crescent catalog a great help. Why not write your letter now?

**Crescent Machine Company,**  
245 Main St.,  
Lectonia, Ohio.

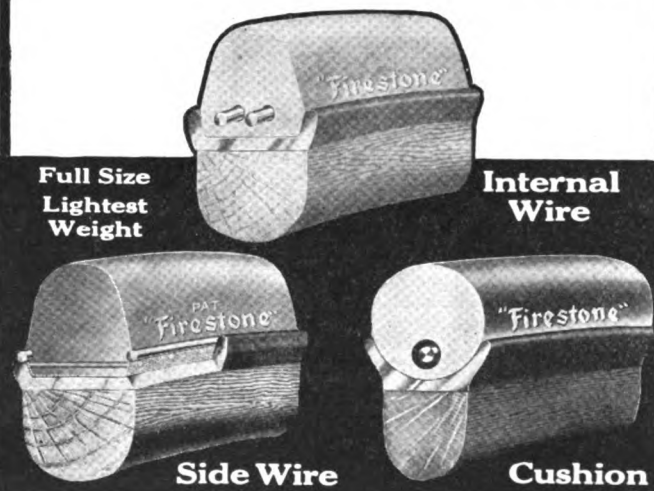
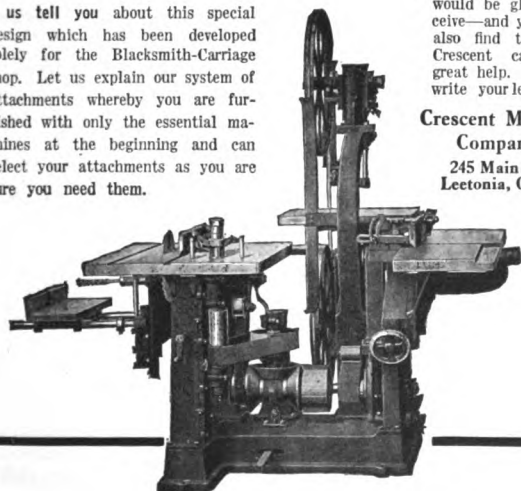

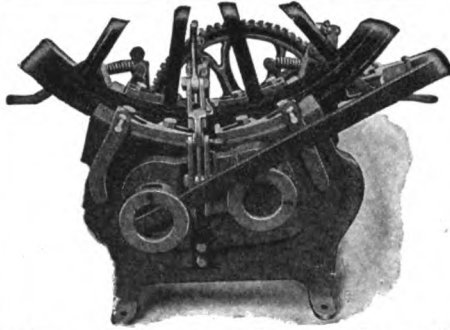

### The Brooks Cold Tire Setter

Sets tires cold on the wheel and is the pioneer edge-grip hand-power cold tire setter. Used and officially endorsed by the United States Government in the Department of War and Interior. Thousands of blacksmiths in the U. S. consider it the most profitable machine in their shop. The Brooks does the work quicker and better than any other cold tire setters on the market and should be in every blacksmith and carriage repairer's shop. Write for catalog and prices.

We are also manufacturers of the latest improved Oxy-Acetylene Welding machines and generators, equipped with our famous Safety Flash Back Valve. It prevents explosions. We also build Welding Outfits to be used with cylinder gases. Our catalog will interest you and is free for the asking.

The Brooks Machine Company, Wichita, Kansas

### The Perfect Power Hammer

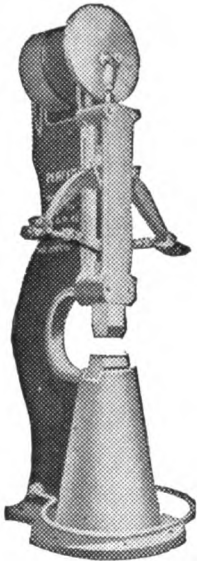

The Simplest in Construction  
The Most Effective in Operation  
The Most Durable and  
**THE BEST**

MADE IN TWO SIZES:  
3 inch square, 40 lb. ram — shipping weight, 1,100 lbs.  
4 inch square, 80 lb. ram — shipping weight, 1,800 lbs.  
Write any jobber for Prices, or

**MACGOWAN & FINIGAN  
FOUNDRY & MACHINE CO.**  
204 North Third Street  
ST. LOUIS, MO.

### "NEW EASY" 4 Sizes BOLT CLIPPERS "EASY" 2 Sizes

THE GENUINE TOOL  
H. K. PORTER



EVERETT, MASS.

KNOWN AND PREFERRED EVERYWHERE  
U. S. A.

### EVER-READY BLANK SHARE

THE BLACKSMITH'S FAVORITE

Can be fitted to more styles of plows than can any other pattern.



To save labor use our Fitted Shares for all makes of plows.

Write for Catalog

### CRESCENT FORGE & SHOVEL COMPANY

MANUFACTURERS OF HIGH GRADE FLOWSHARES AND BLACKSMITHS' BLANKS

HAVANA, ILL., U. S. A.

### "Bay State" Carriage and Tire Bolt Ratchet Wrenches

Labor Savers!  
Money Savers!

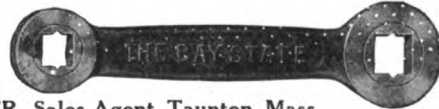

Three Sizes  
Take Hex and Square Nuts

GEO. A. CUTTER, Sales Agent, Taunton, Mass.

Ask Your Dealer

## Horse Shoe Bar Iron

MADE BY

**The Milton Mfg. Company**

**MILTON, PENN'A**

Is of Superior Strength and Quality. We can prove it. Write us.

### THE HORSE RASP OF QUALITY



Ask your dealer for the IMPROVED HELLER RASP with keen cutting hard teeth. Made in all patterns and cuts, "Slim," "Light," "Slim Light," and "Fine Cut." Insist on getting the size, kind and cut best suited for your work. It will pay you to give them a trial. New catalogue mailed free on application.

ESTABLISHED IN 1836

**HELLER BROTHERS COMPANY**

**NEWARK, N. J.**

Electric Wiring Diagrams and Switchboards, by Newton Harrison. 272 Pages — 5x7 1/2 — 105 illustrations. Cloth. Price, \$1.50 (6/6). Norman W. Henley Pub. Co., New York.

This book by the Instructor of Electrical Engineering in Newark Technical School, is a thoroughly practical treatise on electric wiring in all its branches. It begins with the simple facts of wiring and then goes into the more complicated and complex systems. Power and lighting wiring are explained and diagrammed and switchboard work explained. The book is a handy, well-written, instructive and comprehensive volume for the practical electrician.

### TRADE LITERATURE AND NOTES.

There are horseshoes and horseshoes but none like the United States brand made by the U. S. Horse Shoe Company, Erie, Pa. There is more Style, Shape, Perfect punching, and Excellent finish in one keg of U. S. Shoes than in a ton of any other brand. These now famous shoes are made in over 500 different patterns and sizes and are carried in stock by all jobbers. Thousands of discriminating shoers everywhere are using the U. S. Shoes exclusively in their business and would not go back to any other brand they ever before used, which is quite a testimonial for U. S. These shoers appreciate the fact that the United States Horse Shoe Company is trying to do something to stimulate the horse business which means continued or increased prosperity for the shoer, and are therefore reciprocating.



**CURRENT HEAVY HARDWARE PRICES.**

The following quotations are the lowest prices generally prevailing September 15, 1916. They are subject to change without notice, and higher prices are charged according to quality, specification and other conditions.

The entire list of Wood Stock items has been revised where revision was necessary and a slight advance will be noted in most lines.

Iron and steel remain the same. Business continues good and prospects are bright for a good trade during the remaining months of the year. Collections at this time of year should be excellent. If you are not pushing collections, do so immediately.

**Horse Shoes—**

All Iron Shoes	.....\$5.00
Steel Shoes	.....5.00
No. 0 and No. 1, 25 cents extra. 15 cents per keg additional charged for packing more than one size in a keg.	
<b>Mule Shoes—</b>	
X. L. Steel Shoes	.....
Countersunk Steel Shoes	.....
Tip Shoes	.....
Goodenough, heavy	.....
Goodenough, sharp	.....
Toe Weight	.....
Side Weight	.....
E. E. Light Steel	.....
Steel Driving	.....
O. O. Mule Shoes, extra	.....

**Amvils** .....\$ .14 & .15

**Merchant Bar Iron—**  
\$3.30 rates, full extras, and 20 cents per 100 pounds extra for broken bundles.

**Steel Bars—**  
\$3.30 rates, full extras.

**Toe Calks—** Per Box

Blunt	.....\$1.85
Sharp	.....1.90

**Screw Calks—**

	5-16	%	7-16	1/2	%
Blizzard M.	\$20.00	\$20.00	\$22.00	\$22.00	\$24.00
Sure Grip M.	20.00	20.00	22.00	24.00	24.00
Bl. Diamond M.	20.00	20.00	22.00	24.00	24.00
Red Tip M.	22.00	22.00	24.00	24.00	26.00
Rowe, Jr., M.	20.00	20.00	22.00	22.00	24.00
Ring Point M.	22.00	22.00	24.00	24.00	26.00

**Plow Goods—**

	Soft	Solid	Center	Cast	Crucible
Blank Shares	.....\$ .18	.....\$ .12 1/2	.....\$ .13 1/2	.....\$ .13 1/2	.....\$ .13 1/2
Landside Plates	......18	......12 1/2	......13 1/2	......13 1/2	......13 1/2
Lister Lays—Triangle	......23	......15	......17	......17	......17
Lister Lays—V-Pattern	......26	......15 1/2	......17 1/2	......17 1/2	......17 1/2
Lister	......17 1/2	......17 1/2	......17 1/2	......17 1/2	......17 1/2
Mould Boards	......21	......13 1/2	......14 1/2	......14 1/2	......14 1/2
Cult. Shov. Blanks	......20	......13	......15	......15	......15

(5x5—1/2x10 1/2)

**Hickory Lumber—Per Foot—**

1 to 2 1/2	.....\$ .10
1 1/2 to 4 1/2	......12

**Ash and Oak Lumber—Per Foot—**

1—1 1/4	.....\$ .08	2 1/2—3	.....\$ .09
1 1/2—2	......08 1/2	3 1/2—4	......10

**Yellow Poplar Lumber, Per M. Feet—**

	6 to 12	13 to 17	18 to 24
3/4"	.....\$75.00	.....\$75.00	.....\$85.00
1"	.....75.00	.....78.00	.....90.00
1 1/2"	.....78.00	.....85.00	.....95.00
2"	.....85.00	.....90.00	.....114.00
3"	.....85.00	.....90.00	.....114.00

**Rough Hickory Axles—**

3 x 4 x 6 ft.	.....\$ .70
3 1/2 x 4 1/2 x 6 ft.	......95
4 x 5 x 6 ft.	.....1.20
5 x 6 x 6 ft.	.....2.25
4 x 5 x 6 1/2 ft.	.....1.75
4 1/2 x 5 1/2 x 7 ft.	.....2.30
5 x 6 x 7 ft.	.....2.80
6 x 7 x 7 ft.	.....3.40

**Finished Hickory Axles—**

For 2 1/2 and 2 3/4 Skeins	.....\$ .95
For 3 Skeins	.....1.38
For 3 1/2 Skeins	.....1.48
For 3 3/4 Skeins	.....1.63
For 3 1/2 Skeins	.....1.90
For 4 Skeins	.....2.10

**Rough Oak Bolsters—**

3 x 4	.....\$ .36	4 x 4	.....\$ .40	4 x 6	.....\$1.30	4 x 8	.....\$1.55	4 x 10	.....\$1.75
4 x 4	......60	4 x 6	......70	4 x 8	.....2.20	4 x 10	.....2.55	4 x 12	.....3.00
5 x 6	.....1.00	5 x 8	.....1.20						

**Finished Bolsters—**

2 1/2 and 3"	.....56c
3 1/2	.....65c
3 3/4	.....92c

**Rough Oak Wagon Tongues—**

4 x 4, 2 x 4 12 and smaller	.....\$1.15
-----------------------------	-------------

**Finished Oak Wagon Tongues—**

3 1/2 and smaller	.....\$1.35
3 3/4	.....1.45
4	.....1.55

**Two-Inch Sawed Hounds—** Per Pair

Tongues	.....38c
Front	.....44c
Hind	.....55c

**Wheels—**

0 to 71 inch. A. & B. Grades	.....50-5%
C. Grades	.....45-5%
D. Grades	.....45%

**Tiring—1% x %** stocks

factory	.....20%
	.....25%

**Screws—1 1/4"** Thread and less

	.....37 1/2%
--	--------------

**Rivets—1 1/2"** Thread and less

	.....37 1/2%
--	--------------

**Boring or Boxing less than 10 cents lots.**

Boring or Boxing 10 sets or more of one size	.....40%
Priming Wheels, net	.....25c
Oiling, not tired, set	.....20c

**Allowance of 25 cents per set on all special tired wheels with three or four piece rims.**

Oiling, not tired, No. 17 to No. 39	.....25c
Oiling No. 45 and larger	.....40c

**Special Tired Wheels—"F" Grade—3 or 4 piece Rim—**

0 3/4 x 1 1/4"	.....\$8.60	9 1 1/4 x 1 1/4"	.....\$11.57
1 1/4 x 1 1/4"	.....8.99	9 1 1/4 x 5-16"	.....12.48
3 1 x 1 1/4"	.....9.55	13 1 1/4 x 5-16"	.....14.78
3 1 x 5-16"	.....10.40	13 1 1/4 x 3/8"	.....15.75

**Cupped Oak Hubs—**

10 x 14	.....\$3.30	7 x 8 x 9	.....\$1.30
11 x 14	.....4.20	7 x 9 x 10	.....1.50
11 x 15	.....4.50	8 x 9 x 10	.....1.55
11 x 16	.....5.10	8 x 10 x 11	.....1.80
12 x 16	.....5.75	9 x 10 x 11	.....1.95
12 x 17	.....6.30	9 x 11 x 12	.....2.00
13 x 18	.....7.00	10 x 12 x 13	.....3.00
		11 x 13 x 14	.....4.20
		12 x 14 x 15	.....5.10

**Rough Sawed Fellos—**

1 1/2 x 2"	.....\$1.65	2 x 2 1/2"	.....\$1.85
1 3/4 x 1 1/4"	.....1.75	2 1/2 x 2"	.....3.50
1 3/4 x 2 1/2"	.....1.85	3 x 3"	.....5.25
3 x 3 1/2"	.....\$5.75		

**Ironed Poles, White, XXX**

1 1/4 x 2 1/4" No. 2	.....\$5.50
2 x 2 1/2" No. 3	.....5.50

**Ironed Shaft, White, XXX—**

1 3/4 x 2" and smaller	.....\$2.50
1 1/2 x 2"	.....2.75
1 1/2 x 2 1/4"	.....3.55

**Farm Wagon Bows—**

Round Top, 1/2 x 2"	.....\$ .60
Flat Top, 1/2 x 2"	......75
Round Top, 3/8 x 2 1/2"	.....1.35

**Standard Size Piano Bodies with Seats—**

Each	.....\$5.00
------	-------------

**Plow Beams—**

1 Horse	.....\$ .60
2 Horse	......85
3 Horse	.....1.80

**Spokes and Rims—**

Oak and Hickory Spokes, 50% on Weils & Leah	
List No. 8	
Finished Rims—XX—7/8"	.....\$1.75
Finished Rims—XX—1"	.....1.65
Oak Rims—Discounts	.....40-10%
Hickory Rims	.....40%

**Wagon Neck yoke Woods—**

Keller & Tamm's List—Discount	.....25%
-------------------------------	----------

**Wagon Whiffletree Woods—All Grades—**

Keller & Tamm's List—Discount	.....25%
-------------------------------	----------

**Oval Plow Doubletrees—**

2 1/2 x 38"	.....\$1.80	Flat Plow Doubletrees—	
2 x 40"	.....2.40	1 1/4 x 3 1/2 x 42"	.....\$2.75

**Wagon Evener Woods—**

2 x 4 and 2 x 4 1/2—Keller & Tamm's List—Discount	.....30%
Larger	.....25%

**Buggy Evener Woods—All Grades**

Keller & Tamm's List—Discount	.....25%
-------------------------------	----------

**Buggy Whiffletree Woods—**

Mixed Second Growth and Second Growth—Keller & Tamm's List—Discount	.....25%
---	----------

**Buggy Neck yoke Woods—All Grades**

Keller & Tamm's List—Discount	.....25%
-------------------------------	----------

**HONEST DEALINGS**

Before a display advertisement is accepted for this Journal, inquiry is made concerning the standing of the house signing it. Our readers are our friends and their interests will be protected. As a constant example of our good faith in The American Blacksmith advertisers, we will make good to subscribers loss sustained from any who prove to be deliberate swindlers. We must be notified within a month of the transaction giving rise to the complaint. This does not mean that we will concern ourselves with the settlement of petty misunderstandings between subscribers and advertisers, nor will we be responsible for losses of honorable bankrupts, nor can it include advertisements under the head of "Wanted and For Sale."

**STEEL WHEELS**

To Fit Any Axle Plain or Grooved Tire

Steel or Hickory Axles

Any Size A Full Line of Wood and Steel Farm Trucks With Steel or Wood Wheels

Write for Large Catalog and Prices

**ELECTRIC WHEEL CO.**

Box A, Quincy, Ill.

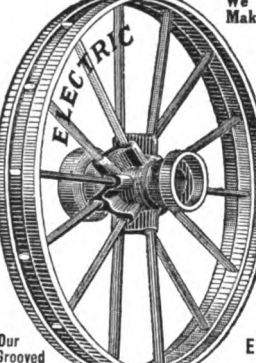

**EMPIRE STEEL WHEELS**

Plain or Grooved Tire

To Fit Any Wagon

Farm Trucks

All Standard Types

Write today for Proposition to Blacksmiths.

**Empire Mfg. Co.**

P. O. Box 306 QUINCY, ILLINOIS



**Best Gasoline Brazing Forge**

IN THE WORLD

Thousands sold in last ten years. Four sizes. Send for catalog.

The National Rubber & Specialties Co.

4433-39 Chickering Ave., Winton Place, Cincinnati, Ohio.



**Improve Your Wagon Work**

by putting on this Threlkold Malleable Iron Standard. Specially designed for wood halsters. Greatly reduces the wear on the side of the box. Note the channel side permits using gas pipe for false standard to give continuous support. Write for circular today.

**DONELSON MFG. CO.,** Chariton, Iowa.



**"GEARS AND WAGONS"**

**Selle Gears**

A quarter of a century of success has placed "Selle Gears" and Wagons in the hands of the largest wagon users in the world. Express and Transfer Companies, Department Stores, Fire Departments, etc.; specify "Selle Gears" and will take no other after once tried.

230 page catalog free

**THE AKRON-SELLE CO.** Akron, Ohio



# Stanley Tools

## STANLEY BLACKSMITH'S BRASS RULES

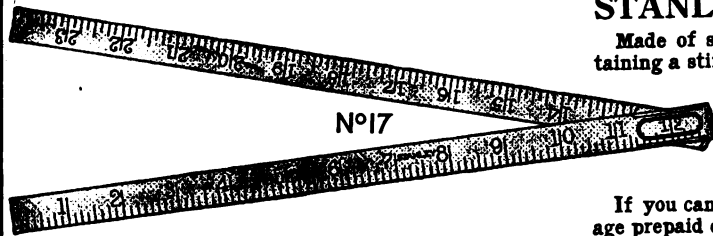

Made of spring brass—the two legs held together by a brass joint containing a stiff spring, which holds the rule rigid when open.

Particularly adapted for measuring hot metal as they can be cooled by plunging in water without the danger of rusting so common in steel rules.

Two ft. long, 3/4 in. wide. Graduated in 8ths and 16ths of inches.

PRICE, \$0.50 EACH

If you cannot procure this Rule from your dealer, we will send same postage prepaid on receipt of the price mentioned above. Address,

**STANLEY RULE & LEVEL CO.**  
NEW BRITAIN, CONN. U.S.A.

# TRENTON ANVILS

*Solid Wrought from Trenton Steel; not cast.  
Recessed Base; stand firmly on the block  
Made in all sizes with all desirable Clips.  
Ring like a Bell and Perfect in Shape.*



THE COLUMBUS FORGE & IRON CO. COLUMBUS, O.

Size	Ounces
No. 0	10
" 1	12
" 2	15½
" 3	19
" 4	23½
" 5	29
" 6	33½
" 7	39
" 8	46



Front

SAMPLES  
FREE UPON  
REQUEST



Hind

### LIGHT

Size	Ounces
No. 0	8½
" 1	11
" 2	13½
" 3	16
" 4	20
" 5	24
" 6	28
" 7	34½
" 8	40½

Manufactured by the  
**BRYDEN HORSE  
SHOE COMPANY**  
—  
CATASAUQUA,  
PENNA.

# BOSS SNOW SHOES

Manufacturers of a Larger  
Variety of

## HORSE and MULE SHOES

Than Any Other Concern  
in the World.

Size	Ounces
No. 1	12
" 2	14
" 3	17
" 4	20
" 5	25
" 6	30
" 7	35½



Front

### EXTRA LIGHT

SEND FOR  
CATALOG  
DESCRIBING  
OUR FULL LINE

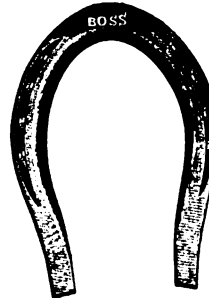

Hind

Size	Ounces
No. 1	9½
" 2	11
" 3	14
" 4	17½
" 5	21
" 6	25
" 7	30½



**CURRENT HEAVY HARDWARE PRICES.**

The following quotations are the lowest prices generally prevailing October 12, 1916. They are subject to change without notice, and higher prices are charged according to quality, specification and other conditions.

An advance to \$3.50 for Iron and Steel will be noted in this column. It is interesting to note in this connection that one year ago in November 1915 issue a price of \$2.05 was announced. Need any other argument be advanced for a raise in smithing prices?

The steel market still continues to advance and still higher prices are looked for before the new year opens. Collections are reported as fair.

**Horse Shoes—**

All Iron Shoes	.....\$5.00
Steel Shoes	.....5.00
No. 0 and No. 1, 25 cents extra. 15 cents per keg additional charged for packing more than one size in a keg.	
Mule Shoes	.....
X. L. Steel Shoes	.....
Countersunk Steel Shoes	.....
Tip Shoes	.....
Goodenough, heavy	.....
Goodenough, sharp	.....
Toe Weight	.....
Side Weight	.....
E. E. Light Steel	.....
Steel Driving	.....
O. O. Mule Shoes, extra	.....

Amvis .....\$14 & .15

**Merchant Bar Iron—**  
\$3.50 rates, full extras, and 20 cents per 100 pounds extra for broken bundles.

**Steel Bars—**  
\$3.50 rates, full extras.

**Toe Calks—**

Blunt	.....	Per Box	.....
Sharp	.....		.....\$1.85
			.....1.90

**Screw Calks—**

	5-16	3/8	7-16	1/2	5/8
Blizzard M.	\$20.00	\$20.00	\$22.00	\$22.00	\$24.00
Sure Grip M.	20.00	20.00	22.00	24.00	24.00
Bl. Diamond M.	20.00	20.00	22.00	24.00	24.00
Red Tip M.	22.00	22.00	24.00	24.00	26.00
Bowe, Jr., M.	20.00	20.00	22.00	22.00	24.00
Ring Point M.	22.00	22.00	24.00	24.00	26.00

**Plow Goods—**

	Soft	Solid	Crucible
	Center	Cast	
Blank Shares	.....\$1.18	.....\$1.12 1/2	.....\$1.13 1/2
Landside Plates	......18	......12 1/2	......18 1/2
Lister Lays—Triangle	......23	......15	......17
Lister Lays—V-Pattern	......26	......15 1/2	......17 1/2
Lister	......17 1/2		
Mould Boards	......21	......13 1/2	......14 1/2
Cult. Shov. Blanks	......20	......13	......15
(5x5—1/2x10 1/2)			

**Hickory Lumber—Per Foot—**

1 to 2 1/2	.....\$ .10
1 1/2 to 4 1/2	......12

**Ash and Oak Lumber—Per Foot—**

1—1 1/2	.....\$.08	2 1/2—3	.....\$.09
1 1/2—2	......08 1/2	3 1/2—4	......10

**Yellow Poplar Lumber, Per M. Feet—**

	6 to 12	13 to 17	18 to 24
3/4"	.....\$75.00	.....\$75.00	.....\$85.00
1"	.....75.00	.....78.00	.....90.00
1 1/4"	.....78.00	.....85.00	.....95.00
1 1/2"	.....85.00	.....90.00	.....114.00
1 3/4"	.....85.00	.....90.00	.....114.00

**Rough Hickory Axles—**

3 x 4 x 6 ft.	.....\$.70
3 1/2 x 4 1/2 x 6 ft.	......95
4 x 5 x 6 ft.	.....1.20
5 x 6 x 6 ft.	.....1.20
4 x 5 x 6 1/2 ft.	.....1.75
4 1/2 x 5 1/2 x 7 ft.	.....2.30
5 x 6 x 7 ft.	.....2.30
5 x 7 x 7 ft.	.....3.40

**Finished Hickory Axles—**

For 2 1/2 and 2 3/4 Skeins	.....\$.95
For 3 Skeins	.....1.38
For 3 1/2 Skeins	.....1.48
For 3 3/4 Skeins	.....1.63
For 3 1/2 Skeins	.....1.90
For 4 Skeins	.....2.10

**Rough Oak Bolsters—**

	x4	x4 1/2	x12	x14	x16
3 x 4	.....\$.36	.....\$.40	.....\$1.30	.....\$1.55	.....\$1.75
4 x 4	......60	......70	.....2.20	.....2.55	.....3.00
5 x 6	.....1.00	.....1.20			

**Finished Bolsters—**

2 3/4 and 3 3/4	.....56c
3 1/4	.....85c
3 3/4	.....92c

**Rough Oak Wagon Tongues—**

4 x 4, 2 x 4 12 and smaller	.....\$1.15
-----------------------------	-------------

**Finished Oak Wagon Tongues—**

3 1/2 and smaller	.....\$1.35
3 3/4	.....1.45
4	.....1.65

**Two-Inch Sawed Hounds—**

	Per Pair
Tongues	.....38c
Front	.....44c
Hind	.....55c

**Wheels—**

0 to 71 inch. A. & B. Grades	.....50-5%
C. Grades	.....45-5%
D. Grades	.....45 %

**Tiring—1 1/2 x 3/8" stocks** ..... 20%  
factory ..... 25%

**Screws—1 1/4" Thread and less** ..... 37 1/2%  
**Rivets—1 1/2" Thread and less** ..... 37 1/2%  
Boring or Boxing less than 10 cents lots ..... 40%  
Boring or Boxing 10 sets or more of one size ..... 60%  
Priming Wheels, net ..... 25c  
Oiling, not tired, set ..... 20c  
Allowance of 25 cents per set on all special tired wheels with three or four piece rims.  
Oiling, not tired, No. 17 to No. 39 ..... 35c  
Oiling No. 45 and larger ..... 40c

**Special Tired Wheels—"F" Grade—3 or 4 piece Rim—**

0 3/4 x 1 1/4"	.....\$8.60	9 1 1/2 x 1 1/4"	.....\$11.57
1 1/4 x 1 1/4"	.....8.99	9 1 1/2 x 5-16"	.....12.48
3 1 x 1 1/4"	.....9.55	13 1 1/2 x 5-16"	.....14.78
3 1 x 5-16"	.....10.40	18 1 1/2 x 3/8"	.....15.75

**Cupped Oak Hubs—**

10 x 14	.....\$3.30	7 x 8 x 9	.....\$1.30
11 x 14	.....4.20	7 x 8 x 10	.....1.50
11 x 15	.....4.50	8 x 9 x 10	.....1.55
11 x 18	.....5.10	8 x 10 x 11	.....1.80
12 x 18	.....5.75	9 x 10 x 11	.....1.95
12 x 17	.....6.30	9 x 11 x 12	.....2.00
13 x 18	.....7.00	10 x 12 x 13	.....3.00
		11 x 13 x 14	.....4.20
		12 x 14 x 15	.....5.10

**Rough Sawed Fellos—**

1 1/2 x 2"	.....\$1.85	2x2 1/2"	.....\$1.85
1 3/4 x 2 1/4"	.....1.75	2 1/2 x 2"	.....3.50
1 3/4 x 2 1/2"	.....1.85	3x3"	.....6.25
3 x 3 1/2"	.....\$5.75		

**Ironed Poles, White, XXX**

1 1/2 x 2 1/4" No. 2	.....\$5.50
2 x 2 1/2" No. 3	.....5.50

**Ironed Shaft, White, XXX—**

1 1/2 x 2" and smaller	.....\$2.50
1 1/2 x 2"	.....2.75
1 1/2 x 2 1/4"	.....3.55

**Farm Wagon Bows—**

Round Top, 1/2 x 2"	.....\$.60
Flat Top, 1/2 x 2"	......75
Round Top, 3/4 x 2 1/4"	.....1.35

**Standard Size Piano Bodies with Seats—**  
Each .....\$5.00

**Plow Beams—**

1 Horse	.....\$.60
2 Horse	......85
3 Horse	.....1.30

**Spokes and Rims—**

Oak and Hickory Spokes, 50% on Weiss & Leash List No. 8.	
Finished Rims—XX—7/8"	.....\$1.75
Finished Rims—XX—1"	.....1.65
Oak Rims—Discounts	.....40-10%
Hickory Rims	.....40%

**Wagon Neckyoke Woods—**  
Keller & Tamm's List—Discount ..... 25%

**Wagon Whiffletree Woods—All Grades—**  
Keller & Tamm's List—Discount ..... 25%

**Oval Plow Doubletrees—**

2 1/2 x 38"	.....\$1.60	1 1/2 x 3 1/2 x 42"	.....\$2.75
2 x 40"	.....2.40		

**Wagon Evener Woods—**

2 x 4 and 2 x 4 1/2—Keller & Tamm's List—Discount	.....30%
Larger	.....25%

**Buggy Evener Woods—All Grades**  
Keller & Tamm's List—Discount ..... 25%

**Buggy Whiffletree Woods—**  
Mixed Second Growth and Second Growth—  
Keller & Tamm's List—Discount ..... 25%

**Buggy Neckyoke Woods—All Grades**  
Keller & Tamm's List—Discount ..... 25%

**HONEST DEALINGS**

Before a display advertisement is accepted for this Journal, inquiry is made concerning the standing of the house signing it. Our readers are our friends and their interests will be protected. As a constant example of our good faith in The American Blacksmith advertisers, we will make good to subscribers loss sustained from any who prove to be deliberate swindlers. We must be notified within a month of the transaction giving rise to the complaint. This does not mean that we will concern ourselves with the settlement of petty misunderstandings between subscribers and advertisers, nor will we be responsible for losses of honorable bankrupts, nor can it include advertisements under the head of "Wanted and For Sale."

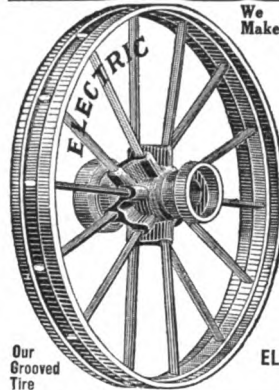

We Make **STEEL WHEELS**

To Fit Any Axle Plain or Grooved Tire

Steel or Hickory Axles

Any Size A Full Line of Wood and Steel Farm Trucks

With Steel or Wood Wheels Write for Large Catalog and Prices

**ELECTRIC WHEEL CO.**  
Box A, Quincy, Ill.

**EMPIRE STEEL WHEELS**

Plain or Grooved Tire

To Fit Any Wagon

Farm Trucks

All Standard Types

Write today for Proposition to Blacksmiths.

**Empire Mfg. Co.**  
P. O. Box 306

QUINCY, ILLINOIS

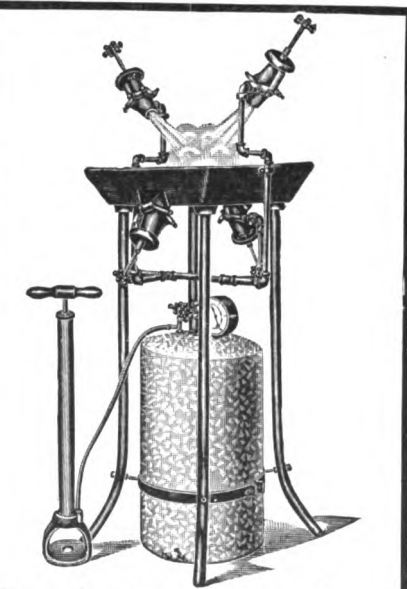

**Best Gasoline Brazing Forge**

IN THE WORLD  
Thousands sold in last ten years. Four sizes. Send for catalog.

The National Rubber & Specialties Co.  
4433-39 Chickering Ave., Winton Place, Cincinnati, Ohio.

**FODEN'S MECHANICAL TABLES**  
**SAVE ALL FIGURING!**  
Tell at a glance how much stock to use for oval or elliptical hoops of any size, the circumferences of circles, weight of flat, square and round stock, and the weight and strength of ropes and chains. Should be in every progressive Smith's hands. Bound very neatly in green cloth. Price, 50c.  
**AMERICAN BLACKSMITH COMPANY, Buffalo, N.Y.**

**"GEARS AND WAGONS"**  
**Selle Gears**  
A quarter of a century of success has placed "Selle Gears" and Wagons in the hands of the largest wagon users in the world. Express and Transfer Companies, Department Stores, Fire Departments, etc., specify "Selle Gears" and will take no other after once tried.  
230 page catalog free  
**THE AKRON-SELLE CO.** Akron, Ohio





# Stanley Tools

## STANLEY BLACKSMITH'S BRASS RULES

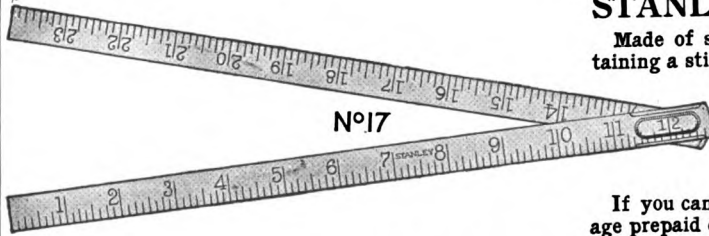

Made of spring brass—the two legs held together by a brass joint containing a stiff spring, which holds the rule rigid when open.

Particularly adapted for measuring hot metal as they can be cooled by plunging in water without the danger of rusting so common in steel rules.

Two ft. long, 3/4 in. wide. Graduated in 8ths and 16ths of inches.

PRICE, \$0.50 EACH

If you cannot procure this Rule from your dealer, we will send same postage prepaid on receipt of the price mentioned above. Address,

**STANLEY RULE & LEVEL CO.**  
NEW BRITAIN, CONN. U.S.A.

# TRENTON ANVILS

*Solid Wrought from <sup>PENTON</sup> New Steel; not cast.  
Recessed Base; stand firmly on the block  
Made in all sizes with all desirable Clips.  
Ring like a Bell and Perfect in Shape.*

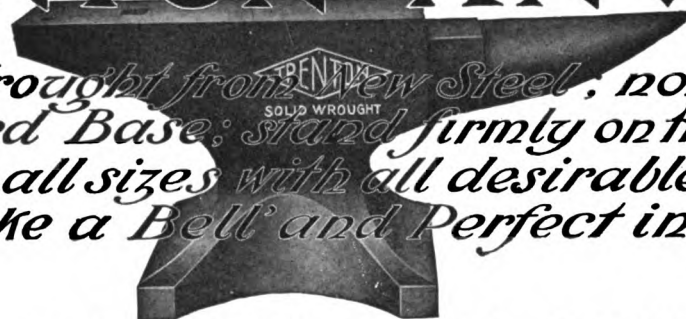

**THE COLUMBUS FORGE & IRON CO. COLUMBUS, O.**

Size	Ounces
No. 0	10
" 1	12
" 2	15 1/2
" 3	19
" 4	23 1/2
" 5	29
" 6	33 1/2
" 7	39
" 8	46



SAMPLES  
FREE UPON  
REQUEST



Size	Ounces
No. 0	8 1/2
" 1	11
" 2	13 1/2
" 3	16
" 4	20
" 5	24
" 6	28
" 7	34 1/2
" 8	40 1/2

### LIGHT

# BOSS SNOW SHOES

Manufactured by the  
**BRYDEN HORSE  
SHOE COMPANY**  
—  
CATASAUQUA,  
PENNA.

Manufacturers of a Larger  
Variety of

## HORSE and MULE SHOES

Than Any Other Concern  
in the World.

Size	Ounces
No. 1	12
" 2	14
" 3	17
" 4	20
" 5	25
" 6	30
" 7	35 1/2



### EXTRA LIGHT

SEND FOR  
CATALOG  
DESCRIBING  
OUR FULL LINE



Size	Ounces
No. 1	9 1/2
" 2	11
" 3	14
" 4	17 1/2
" 5	21
" 6	25
" 7	30 1/2



# Sweet's Welded Toe Calks Make More Shoeing For You

## ARE YOU DRIVING TRADE AWAY FROM YOUR SHOP?

A horse shod with *welded toe calks* does not stay away from your shop two or three months at a time. The horse owner *can't* fit these calks. He *has* to bring the horse to you. He has to come *regularly*. If you want your shop empty half the time, use shoes in which the owner *can* fit calks. If you want better business, better profits, use

Sweet's Toe Calks  
"The Cold Cut Dreadnaught"

Franklin Steel Works

Joliet, Ill.  
Cambridge,  
Mass.

Hamilton, Ont.



## Don't Let Opportunity Slip Through Your Hands

While other Smiths are taking up a lot of new wrinkles do the sensible thing and go into woodworking *right*. That means a complete equipment and no outfit will give you the service of this

### FAMOUS WOODWORKER

Easy to Use—Easy to Buy

Let this woodworker pay for self. You can have it earn its low purchase price by our convenient easy payment plan. Write for the details without delay.

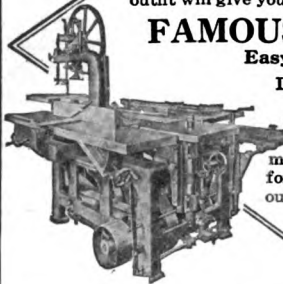

Sidney Tool Co.  
Sidney, Ohio.

## Butterfield's Screw Plates

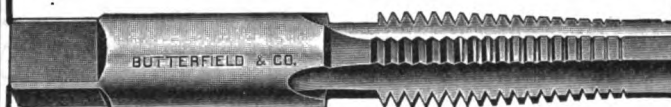

We do not claim to be the oldest manufacturers of Screw Plates. We are not sure that this is any distinction.

Our claims for the superiority of our TAPS and SCREW PLATES are based on actual performance. The rapid growth of our business, is proof positive of the excellence of our product.

Be sure you ask for BUTTERFIELD'S, and take no substitute.

**BUTTERFIELD & CO.**

NEW YORK STORE, 126 Chambers St. DERBY LINE, VT., U. S. A.

### TRADE LITERATURE AND NOTES Simple Device That Solves Vexatious Problems for Users of Machinery.

Ever since machinery has been built and used, one particular problem has existed to vex and perplex the maker and user. The problem is: How to prevent the nuts from working off the bolts. It is a problem that has entailed ceaseless vigilance, for a nut that has worked off may wreck a costly machine, may pile a fast railroad train into junk, or send a great steamship and hundreds of souls to the bottom of the ocean.

Once there is a demand for an article the American inventor may be relied upon to fill it. So the makers and users of machinery may now cease from worrying. The way has been found to keep the nuts in their proper places, and at trifling cost. And this fact gives the news that the Spring Nut Lock has been placed on the market. It is news that means greater safety and therefore greater efficiency for all kinds of machinery. It is news that affects practically every line of industrial activity.

The Spring Nut Lock is a little invention that makes it impossible for a nut to drop off the bolt on which it is placed. It also holds the nut securely at the point placed. No matter how great the vibration of the machinery may be—and it is vibration that causes the nuts to fall off—the nut cannot budge from its position. The Spring Nut Lock, in effect, makes the nut as stable and as safe as a rivet, with this important advantage over the rivet—the lock and the nut can be quickly and easily removed at any time and repeatedly used, with no injury to the bolt threads.

It is one of those simple devices that,

like the gimlet pointed screw, appear so obvious. The Spring Nut Lock consists of two plates of thin steel stamped out of one piece, leaving a joint in the center. Circular holes to fit the required size of bolt are punched in each plate, and the plate is then bent over until the two holes are almost parallel—almost, but not quite, as one hole will overlap the other hole by a mere fraction of an inch. The joining side acts as a hinge and after being tempered, as a powerful spring.

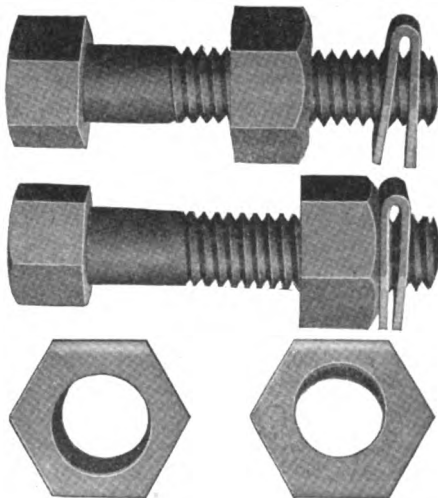

The device is not an experiment—that stage has been passed. It has been given the most rigorous tests, notably by the superintendent of Motive Power and Machinery of the Chicago and North Western Railroad. This official tested the Lock on locomotives, trailers and crossing splice

### AT LAST A Steel Plugged Horseshoe

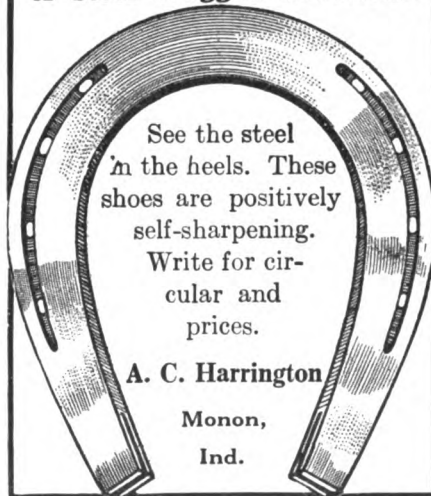

See the steel in the heels. These shoes are positively self-sharpening. Write for circular and prices.

A. C. Harrington

Monon,  
Ind.

bolts, some of these tests lasting sixteen months, and not one failure was reported. Of one of these locomotive tests which had been going on for over a year this gentleman wrote:

"The Spring Nut Lock has held better and longer than any other similar device ever called to my attention."

Wherever machinery is used—wherever a nut is placed on a bolt—from the locomotives of the railroads and the engine room of steamships, to the thrashing machines and reapers of the farm—there will be a market and a demand for Spring Nut Locks. The demand will be for almost

(Continued on page 50)

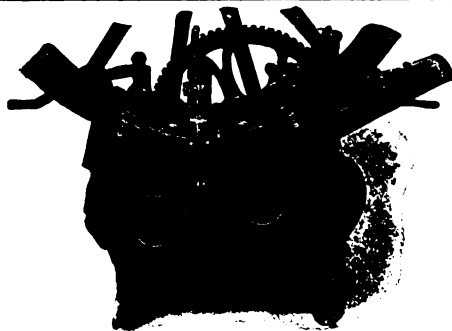

### The Brooks Cold Tire Setter

Sets tires cold on the wheel and is the pioneer edge-grip hand-power cold tire setter. Used and officially endorsed by the United States Government in the Department of War and Interior. Thousands of blacksmiths in the U. S. consider it the most profitable machine in their shop. The Brooks does the work quicker and better than any other cold tire setters on the market and should be in every blacksmith and carriage repairer's shop. Write for catalog and prices.

We are also manufacturers of the latest improved Oxy-Acetylene Welding machines and generators, equipped with our famous Safety Flash Back Valve. It prevents explosions.

We also build Welding Outfits to be used with cylinder gases.

Our catalog will interest you and is free for the asking.

The Brooks Machine Company, Wichita, Kansas

### The Perfect Power Hammer



The Simplest in Construction  
The Most Effective in Operation  
The Most Durable and  
**THE BEST**

MADE IN TWO SIZES:

3 inch square, 40 lb. ram — shipping weight, 1,100 lbs.

4 inch square, 80 lb. ram — shipping weight, 1,800 lbs.

Write any jobber for Prices, or

**MACGOWAN & FINIGAN  
FOUNDRY & MACHINE CO.**  
204 North Third Street  
ST. LOUIS, MO.

### "NEW EASY" 4 Sizes BOLT CLIPPERS "EASY" 2 Sizes

THE GENUINE TOOL



KNOWN AND PREFERRED EVERYWHERE

H. K. PORTER

EVERETT, MASS.

U. S. A.

### EVER-READY BLANK SHARE

THE BLACKSMITH'S FAVORITE

Can be fitted to more styles of plows than can any other pattern.



To save labor use our Fitted Shares for all makes of plows.

Write for Catalog

### CRESCENT FORGE & SHOVEL COMPANY

MANUFACTURERS OF HIGH GRADE FLOWSHARES AND BLACKSMITHS' BLANKS

HAVANA, ILL., U. S. A.

### "Bay State" Carriage and Tire Bolt Ratchet Wrench

Labor Savers!  
Money Savers!

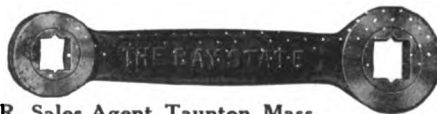

Three Sizes  
Take Hex and Square Nuts

GEO. A. CUTLER, Sales Agent, Taunton, Mass.

Ask Your Dealer

## Horse Shoe Bar Iron

MADE BY

**The Milton Mfg. Company**

**MILTON, PENN'A**

Is of Superior Strength and Quality. We can prove it. Write us.

### THE HORSE RASP OF QUALITY



Ask your dealer for the IMPROVED HELLER RASP with keen cutting hard teeth. Made in all patterns and cuts. "Slim," "Light," "Slim Light," and "Fine Cut." Insist on getting the size, kind and cut best suited for your work. It will pay you to give them a trial. New catalogue mailed free on application.

ESTABLISHED IN 1856

**HELLER BROTHERS COMPANY**

**NEWARK, N. J.**

#### TRADE LITERATURE AND NOTES.

(Continued from page 49)  
countless millions each year. Take the automobile industry alone. There are about 3,500,000 automobiles in the country and the yearly production is considerably over 1,000,000. Every one of these automobiles has numerous bolts and nuts, and every one is a prospective customer for Spring Nut Locks. The builders, keen and quick to grasp every safety device for their cars, will require millions of the Locks every year.

This demand the Spring Nut Lock Company of 608 South Dearborn Street, Chicago, has prepared to meet. It has contracted with The Stowell Company of South Milwaukee, Wisconsin, which has one of the largest industrial plants of the Milwaukee district, and this company has

installed a number of the necessary machines and is now turning out the Locks in the sizes most generally used.

#### SEND US YOUR ORDERS

We Always Have The Stock

### BEALS & COMPANY

Iron, Steel, Hardware  
Blacksmiths' and Wagon Makers' Supplies

**BUFFALO, N. Y.**

Largest stock of iron and steel in New York State

**CURRENT HEAVY HARDWARE PRICES.**

The following quotations are the lowest prices generally prevailing November 14, 1916. They are subject to change without notice, and higher prices are charged according to quality, specification and other conditions. An advance to \$3.80 for Iron and Steel is announced in this column this month. Prices on horseshoes are also announced with an advance to \$5.80, while toe calks show a similar raise. Prices seem to be firmer than ever with little or no tendency toward breaks. Business is generally reported as good while collections have shown a decided increase.

<b>Horse Shoes—</b>		
All Iron Shoes	\$5.30	
Steel Shoes	5.30	
No. 0 and No. 1, 25 cents extra.	15 cents per keg additional charged for packing more than one size in a keg.	
<b>Mule Shoes—</b>		
X. L. Steel Shoes		
Countersunk Steel Shoes	\$6.55	
Tip Shoes		
Goodenough, heavy		
Goodenough, sharp		
Toe Weight, pr.	.25	
Side Weight, pr.	.25	
E. E. Light Steel	6.30	
Steel Driving		
O. O. Mule Shoes, extra		
<b>Awls</b>	\$.14 & .15	
<b>Merchant Bar Iron—</b>		
\$3.60 rates, full extras, and 20 cents per 100 pounds extra for broken bundles.		
<b>Steel Bars—</b>		
\$3.60 rates, full extras.		
<b>Toe Calks—</b>		
Blunt	Per Box \$1.75	
Sharp	2.00	
<b>Screw Calks—</b>		
5-16	7-16	
Blizzard M.	\$20.00 \$20.00 \$22.00 \$22.00 \$24.00	
Sure Grip M.	20.00 20.00 22.00 24.00 24.00	
Bl. Diamond M.	20.00 20.00 22.00 24.00 24.00	
Red Tip M.	22.00 22.00 24.00 24.00 26.00	
Rowe, Jr., M.	20.00 20.00 22.00 22.00 24.00	
Ring Point M.	22.00 22.00 24.00 24.00 26.00	
<b>Plow Goods—</b>		
Blank Shares	Soft \$1.18 Center \$1.12 Solid \$1.13 Crucible \$1.14	
Landside Plates	.18 .12% .18% .18%	
Lister Lays—Triangle	.23 .15 .17	
Lister Lays—V-Pattern	.26 .15% .17%	
Lister	.17%	
Mould Boards	.21 .13% .14%	
Cult. Shov. Blanks	.20 .13 .15	
(5x5—1/2x10 1/2)		
<b>Hickory Lumber—Per Foot—</b>		
1 to 2 1/2	\$.10	
3/4 to 4 1/4	.12	
<b>Ash and Oak Lumber—Per Foot—</b>		
1—1 1/2	\$.08 2 1/2—3 \$.09	
1 1/2—2	.08 3 1/2—4 .10	
<b>Yellow Poplar Lumber, Per M. Feet—</b>		
6 to 12	13 to 17	18 to 24
1/2	\$75.00	\$85.00
3/4	75.00	80.00
1	78.00	85.00
1 1/4	85.00	90.00
1 1/2	85.00	90.00
<b>Rough Hickory Axles—</b>		
3 x 4 x 6 ft.	\$.70	
3 1/2 x 4 1/2 x 6 ft.	.95	
4 x 5 x 6 ft.	1.20	
5 x 6 x 6 ft.	2.25	
4 x 5 x 6 1/2 ft.	1.75	
4 1/2 x 5 1/2 x 7 ft.	2.30	
5 x 6 x 7 ft.	2.80	
5 x 7 x 7 ft.	3.40	
<b>Finished Hickory Axles—</b>		
For 2 1/2 and 3 1/2 Skeins	\$.95	
For 3 Skeins	1.38	
For 3 1/2 Skeins	1.48	
For 3 3/4 Skeins	1.68	
For 3 1/2 Skeins	1.90	
For 4 Skeins	2.10	
<b>Rough Oak Bolsters—</b>		
3 x 4	1.40 1.80 1.80 1.80 1.80	
4 x 4	.60 .70 2.20 2.55 3.00	
5 x 6	1.00 1.20	

<b>Finished Bolsters—</b>			
2 1/2 and 3 1/2	56c		
3 1/2	65c		
3 3/4	92c		
<b>Rough Oak Wagon Tongues—</b>			
4 x 4, 2 x 4 12 and smaller	\$1.15		
<b>Finished Oak Wagon Tongues—</b>			
3 1/2 and smaller	\$1.35		
3 3/4	1.45		
4	1.55		
<b>Two-Inch Sawed Hounds—</b>			
Tongues	Per Pair 38c		
Front	44c		
Hind	55c		
<b>Wheels—</b>			
0 to 71 inch. A. & B. Grades	50-5%		
C. Grades	45-5%		
D. Grades	45%		
Tiring—1 1/2 x 3/4" stocks	20%		
factory	25%		
Screws—1 1/2" Thread and less	37 1/2%		
Rivets—1 1/2" Thread and less	37 1/2%		
Boring or Boring less than 10 cents lots	40%		
Boring or Boring 10 sets or more of one size	60%		
Priming Wheels, net.	25c		
Oiling, not tired, set.	20c		
Allowance of 25 cents per set on all special tired wheels with three or four piece rims.			
Oiling, not tired, No. 17 to No. 39	25c		
Oiling No. 45 and larger	40c		
<b>Special Tired Wheels—"F" Grade—3 or 4 piece Rim—</b>			
0 3/4 x 3/4"	\$8.60	9 1/4 x 3/4"	\$11.57
1 1/2 x 3/4"	8.99	9 1/2 x 5-16"	12.48
3 1 x 3/4"	9.55	18 1/4 x 5-16"	14.78
3 1 x 5-16"	10.40	18 1/4 x 3/4"	15.75
<b>Cupped Oak Hubs—</b>			
10 x 14	\$3.30	<b>Plain End Oak Hubs—</b>	
11 x 14	4.20	7 x 8 x 9	\$1.30
11 x 15	4.50	7 x 9 x 10	1.50
11 x 16	5.10	8 x 9 x 10	1.55
12 x 16	5.75	8 x 10 x 11	1.80
12 x 17	6.30	9 x 10 x 11	1.95
13 x 18	7.00	9 x 11 x 12	2.00
		10 x 12 x 13	3.00
		11 x 13 x 14	4.20
		12 x 14 x 15	5.10
<b>Rough Sawed Fellos—</b>			
1 1/2 x 2 1/2"	\$1.65	2 3/4 x 3 1/2"	\$1.85
1 3/4 x 2 1/2"	1.75	3 1/2 x 3 1/2"	3.50
1 3/4 x 2 3/4"	1.85	3 3/4 x 3 1/2"	5.25
8 x 3 1/2"	\$5.75		
<b>Ironed Poles, White, XXX</b>			
1 1/2 x 2 1/2" No. 2	\$5.50		
2 x 3 1/2" No. 3	5.50		
<b>Ironed Shaft, White, XXX—</b>			
1 1/2 x 2" and smaller	\$2.50		
1 1/2 x 2 1/2"	2.75		
1 1/2 x 3 1/2"	3.55		
<b>Farm Wagon Bows—</b>			
Round Top, 1/2 x 2"	\$.60		
Flat Top, 1/2 x 2"	.75		
Round Top, 3/4 x 2 1/2"	1.35		
<b>Standard Size Piano Bodies with Seats—</b>			
Each	\$5.00		
<b>Plow Beams—</b>			
1 Horse	\$.60		
2 Horse	.85		
3 Horse	1.20		
<b>Spokes and Rims—</b>			
Oak and Hickory Spokes, 50% on Weiss & Lesh List No. 8.			
Finished Rims—XX—7/8"	\$1.75		
Finished Rims—XX—1"	1.65		
Oak Rims—Discounts	40-10%		
Hickory Rims	40%		
<b>Wagon Neckpoke Woods—</b>			
Keller & Tamm's List—Discount	25%		
<b>Wagon Whiffletree Woods—All Grades—</b>			
Keller & Tamm's List—Discount	25%		
<b>Oval Plow Doubletrees—</b>			
2 3/4 x 26"	\$1.60	Flat Plow Doubletrees—	
2 x 40"	2.40	1 1/2 x 8 1/2 x 42"	\$2.75
<b>Wagon Evener Woods—</b>			
2 x 4 and 2 x 4 1/2—Keller & Tamm's List—Discount	30%		
Larger	25%		
<b>Buggy Evener Woods—All Grades</b>			
Keller & Tamm's List—Discount	25%		
<b>Buggy Whiffletree Woods—</b>			
Mixed Second Growth and Second Growth—Keller & Tamm's List—Discount	25%		
<b>Buggy Neckpoke Woods—All Grades</b>			
Keller & Tamm's List—Discount	25%		

**HONEST DEALINGS**  
 Before a display advertisement is accepted for this Journal, inquiry is made concerning the standing of the house signing it. Our readers are our friends and their interests will be protected. As a constant example of our good faith in The American Blacksmith advertisers, we will make good to subscribers loss sustained from any who prove to be deliberate swindlers. We must be notified within a month of the transaction giving rise to the complaint. This does not mean that we will concern ourselves with the settlement of petty misunderstandings between subscribers and advertisers, nor will we be responsible for losses of honorable bankrupts, nor can it include advertisements under the head of "Wanted and For Sale."

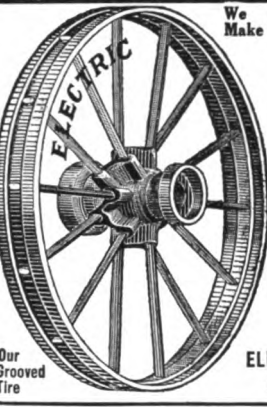

**WE Make STEEL WHEELS**  
 To Fit Any Axle  
 Plain or Grooved  
 Tire  
**Steel or Hickory Axles**  
 Any Size  
 A Full Line of  
 Wood and Steel  
**Farm Trucks**  
 With Steel or  
 Wood Wheels  
 Write for Large  
 Catalog and  
 Prices  
**ELECTRIC WHEEL CO.**  
 Box A, Quincy, Ill.



**EMPIRE STEEL WHEELS**  
 Plain or Grooved  
 Tire  
 To Fit Any Wagon  
**Farm Trucks**  
 All Standard Types  
 Write today for  
 Proposition to Blacksmiths.  
**Empire Mfg. Co.**  
 P. O. Box 386  
 QUINCY, ILLINOIS

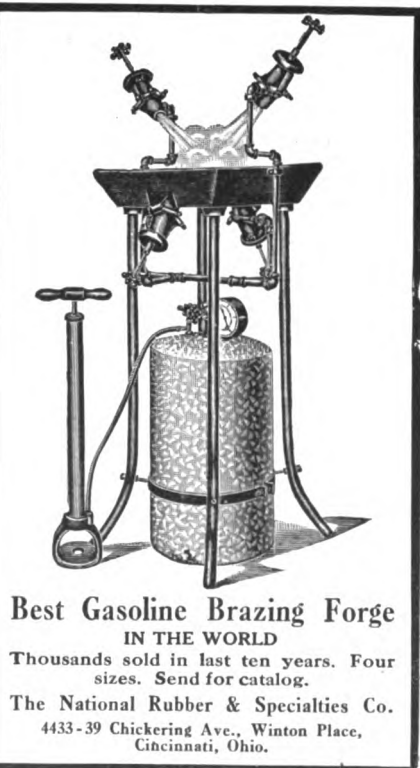

**Best Gasoline Brazing Forge**  
 IN THE WORLD  
 Thousands sold in last ten years. Four sizes. Send for catalog.  
**The National Rubber & Specialties Co.**  
 4433-39 Chickering Ave., Winton Place,  
 Cincinnati, Ohio.

**FODEN'S MECHANICAL TABLES**  
**SAVE ALL FIGURING!**  
 Tell at a glance how much stock to use for oval or elliptical hoops of any size, the circumferences of circles, weight of flat, square and round stock, and the weight and strength of ropes and chains. Should be in every progressive Smith's hands. Bound very neatly in green cloth. Price, 50c.  
**AMERICAN BLACKSMITH COMPANY, Buffalo, N.Y.**

**"GEARS AND WAGONS"**  
**Selle Gears**  
 A quarter of a century of success has placed "Selle Gears" and Wagons in the hands of the largest wagon users in the world. Express and Transfer Companies, Department Stores, Fire Departments, etc.; specify "Selle Gears" and will take no other after once tried.  
 230 page catalog free  
**THE AKRON-SELLE CO. Akron, Ohio**



# Stanley Tools

## STANLEY BLACKSMITH'S BRASS RULES

Made of spring brass—the two legs held together by a brass joint containing a stiff spring, which holds the rule rigid when open.

Particularly adapted for measuring hot metal as they can be cooled by plunging in water without the danger of rusting so common in steel rules.

Twoft. long, 3/4 in. wide. Graduated in 8ths and 16ths of inches.

PRICE, \$0.50 EACH

If you cannot procure this Rule from your dealer, we will send same postage prepaid on receipt of the price mentioned above. Address,

**STANLEY RULE & LEVEL CO.**  
NEW BRITAIN, CONN. U.S.A.

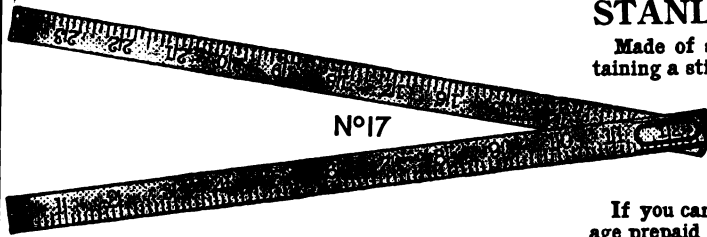

# TRENTON ANVILS

*Solid Wrought from <sup>PENTON</sup> New Steel, not cast.  
Recessed Base; stand firmly on the block  
Made in all sizes with all desirable Clips.  
Ring like a Bell and Perfect in Shape.*



**THE COLUMBUS FORGE & IRON CO. COLUMBUS, O.**

Size	Ounces
No. 0	10
" 1	12
" 2	15 1/2
" 3	19
" 4	23 1/2
" 5	29
" 6	33 1/2
" 7	39
" 8	46



SAMPLES  
FREE UPON  
REQUEST



Size	Ounces
No. 0	8 1/2
" 1	11
" 2	13 1/2
" 3	16
" 4	20
" 5	24
" 6	28
" 7	34 1/2
" 8	40 1/2

### LIGHT

Manufactured by the  
**BRYDEN HORSE  
SHOE COMPANY**  
—  
CATASAUQUA,  
PENNA.

# BOSS SNOW SHOES

Manufacturers of a Larger  
Variety of  
**HORSE and  
MULE SHOES**  
Than Any Other Concern  
in the World.

Size	Ounces
No. 1	12
" 2	14
" 3	17
" 4	20
" 5	25
" 6	30
" 7	35 1/2



### EXTRA LIGHT

SEND FOR  
CATALOG  
DESCRIBING  
OUR FULL LINE



Size	Ounces
No. 1	9 1/2
" 2	11
" 3	14
" 4	17 1/2
" 5	21
" 6	25
" 7	30 1/2



# Quit Driving Your Trade Away

Stop! Look! Think! Every time you put on a set of calks that an owner can replace himself you are driving trade away from your shop.

When you use *welded* calks the owner must bring his horse to the shop when the calks need renewing.

Also every horse's hoofs need the frequent attention of a horseshoer. You're doing the owner a good turn by using SWEET'S TOE CALKS—"The Cold Cut Dreadnaught"—as well as keeping your shop full.



**Franklin Steel Works,**  
Joliet, Ill.  
Cambridge, Mass.  
Hamilton, Ont.

## A GREAT BARGAIN

Here's a chance to get a genuine American Calking Machine at YOUR OWN PRICE. Guaranteed to be as good as new. Now is the time to buy a calking machine and put it to work making money for you. For further particulars. Address

**A. W. B. A.**  
Care of American Blacksmith Co., Buffalo, N. Y.

## DO IT NOW

GET A LINE on Sherwood's Wood Working Machinery, the heavy substantial kind, made expressly for the wagon maker.

- Complete Jointers 5 in. to 13 in.
- Bench Jointers 5 in. and 7 in.

Combined Jointers and Saw Tables with various attachments.

Cutter Heads for Wood Table Jointers.

Combined Cutter Heads and Saw Arbors.

Special Cutter Heads for Planers, Jointers, Saw Arbors, Moulders and any other Wood Working Machine, also Knives, Saw Arbors any size from the smallest to the largest.

Emory Stands for Tool and Sickle Grinding.

Grindstone Shafts from \$1.50 up to \$20.00.

All Steel Handy Drill.

Cast Iron Anvil Blocks that enable the blacksmith to turn out a third more work.

Catalogue No. 12 for further information, YOURS for the asking.

Make machinery do your work and here's where running a shop ceases to be a drudgery when you are using any of the above machinery. Get Easy.

**W. L. SHERWOOD,** KIRKSVILLE, MO.

**Make Your "Big Push" Now**

The fort of extra profits is ready to fall into your hands if you will only bring up the proper artillery. And there is no weapon as certain to hit every time as taking up woodworking with a **FAMOUS WOODWORKER**

*Easy to Use—Easy to Buy*

This complete woodworker—sturdy and long lasting—is yours at the low price of \$125 and up. And you don't have to pay that all at one time unless you prefer. Let us explain our exceptionally liberal offer.

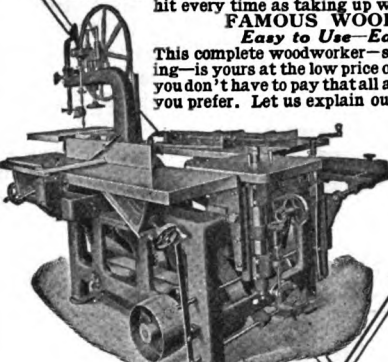

Write us for the details and a new free circular *at once*.

**Sidney Tool Company**  
Sidney, Ohio, U. S. A.

## Butterfield's Screw Plates



We do not claim to be the oldest manufacturers of Screw Plates. We are not sure that this is any distinction.

Our claims for the superiority of our TAPS and SCREW PLATES are based on actual performance. The rapid growth of our business, is proof positive of the excellence of our product.

Be sure you ask for BUTTERFIELD'S, and take no substitute.

**BUTTERFIELD & CO.**  
NEW YORK STORE, 126 Chambers St. DERBY LINE, VT., U. S. A.

## Why Not Be Sure



Showing Spring Nut Lock applied loose on bolt before being set in place to hold until taken off.

that every part of the engine; chassis, or body of the car or other machinery you make or repair will **stay together** until taken apart?

## Spring Nut Locks

are the simplest, surest, safest device to **positively lock** any nut on any bolt. Resists all vibrations. Cannot harm threads. Easily applied. Released whenever desired.

### Cheapest and Best

**Manufacturers, Jobbers, Garage Men, Repair Men and all Dealers** should write for prices on sizes now available. Orders filled in rotation. All sizes by January 1st.

**Spring Nut Lock** tightened against Nut. Prevents Nut being shaken off and follows Nut tight ening against material.



**Spring Nut Lock Company**  
653 Transportation Bldg.  
Chicago

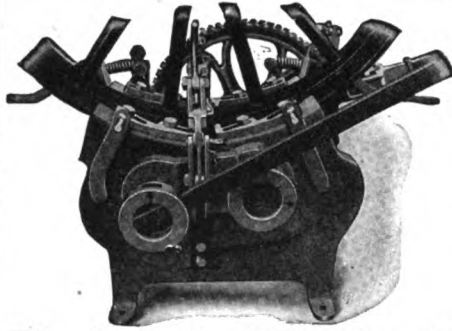

### The Brooks Cold Tire Setter

Sets tires cold on the wheel and is the pioneer edge-grip hand-power cold tire setter. Used and officially endorsed by the United States Government in the Department of War and Interior. Thousands of blacksmiths in the U. S. consider it the most profitable machine in their shop. We build both hydraulic and lever cold tire setters. The Brooks does the work quicker and better than any other cold tire setter on the market and should be in every blacksmith and carriage repairer's shop. Write for catalog and prices.

We are also manufacturers of the latest improved Oxy-Acetylene Welding machines and generators, equipped with our famous Safety Flash Back Valve. It prevents explosions.

We also build Welding Outfits to be used with cylinder gases.

Our catalog will interest you and is free for the asking.

The Brooks Machine Company, Wichita, Kansas

### The Perfect Power Hammer

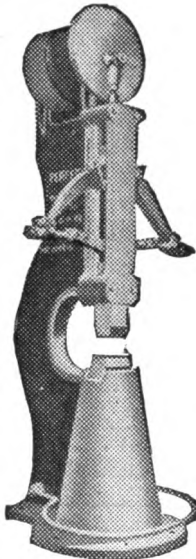

The Simplest in Construction  
The Most Effective in Operation  
The Most Durable and

**THE BEST**

MADE IN TWO SIZES:

3 inch square, 40 lb. ram — shipping weight, 1,100 lbs.  
4 inch square, 80 lb. ram — shipping weight, 1,800 lbs.  
Write any jobber for Prices, or

**MACGOWAN & FINIGAN  
FOUNDRY & MACHINE CO.**  
204 North Third Street  
ST. LOUIS, MO.

**"NEW EASY" 4 Sizes BOLT CLIPPERS "EASY" 2 Sizes**

THE GENUINE TOOL



KNOWN AND PREFERRED EVERYWHERE

H. K. PORTER EVERETT, MASS. U. S. A.

**EVER-READY BLANK SHARE** THE BLACKSMITH'S FAVORITE



Can be fitted to more styles of plows than can any other pattern.

To save labor use our Fitted Shares for all makes of plows.

Write for Catalog

**CRESCENT FORGE & SHOVEL COMPANY**  
MANUFACTURERS OF HIGH GRADE FLOWSHARES AND BLACKSMITHS' BLANKS  
HAVANA, ILL., U. S. A.

**"Bay State" Carriage and Tire Bolt Ratchet Wrenches**

Labor Savers! Money Savers!



Three Sizes Take Hex and Square Nuts

Ask Your Dealer

GEO. A. CUTTER, Sales Agent, Taunton, Mass.

## Horse Shoe Bar Iron

MADE BY

**The Milton Mfg. Company**  
**MILTON, PENN'A**

Is of Superior Strength and Quality. We can prove it. Write us.

**THE HORSE RASP OF QUALITY**



Ask your dealer for the IMPROVED HELLER RASP with keen cutting hard teeth. Made in all patterns and cuts. "Slim," "Light," "Slim Light," and "Fine Cut." Insist on getting the size, kind and cut best suited for your work. It will pay you to give them a trial. New catalogue mailed free on application.

ESTABLISHED IN 1836

**HELLER BROTHERS COMPANY** NEWARK, N. J.

#### TRADE LITERATURE AND NOTES.

No modern smithing shop seems to be complete without its own woodworking establishment. It gives the smith a chance to handle many jobs which ordinarily he would send out to the planing mill, and to add a great deal to his annual profits.

Perhaps the easiest way for a blacksmith to get his woodworking equipment is to build it himself, and this can be easily done in his own shop with a little lumber, sharp tools and the attachments made by JOHN WHISLER of Gibson, Iowa.

These are jointer heads and can be used for dressing common boards, axles, etc., finishing plow and wagon tongues, double-trees, railings, etc., and with one or two

attachments can be turned into a lathe for short pieces of work, such as mallets, chisel handles, patterns, balls, or anything under 8 inches in length; or used as a saw arbor and dadoing.

Operates on 2 H. P. at from 2,500 to 3,500 R. P. M.

The same company also manufactures a handy little nut-splitter that is a great time saver for smiths. Wherever bolts are loose and turn with the nuts, or threads are rusted fast, it is a great help.

Catalogs describing the Nut-Splitters, Jointer Heads, Power Grindstone, Shop and Engine Trucks, Shafts, etc., may be had free on request, by writing to the above address.



The incomparable 400 Blower, the one great heirloom that will be handed down from one generation to the other. Ask what the owners say. **MADE WITH BALL BEARINGS ONLY.**

## OVER 750,000 CHAMPION 400 BLOWERS IN USE.

The 400 is the Blower that has revolutionized the World in making Hand Blast.

**Tuyere Iron That Makes a Whirlwind Blast**

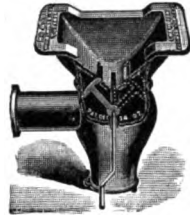

The "Whirlwind" Blast Anti-Clinker, Heavy Nest Tuyere Iron produces a circular, rotary whirlwind blast and concentrates the heat in the tuyere nest, not permitting it to blow up and out of the chimney, therefore makes a better fire and heats the iron one-third quicker, saving much coal.

The No. 400 "Whirlwind" Blast, Anti-Clinker, Heavy Nest Tuyere Iron is furnished with all 400 Blowers WITH-OUT EXTRA COST.



Crank turns other way

No. 400.



No. 408. Steel Blacksmiths' Forge.

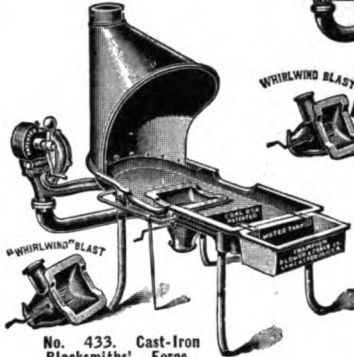

No. 433. Cast-Iron Blacksmiths' Forge.



HERCULES PATENTED POWER HAMMER

Weight of ram, 65 pounds. The Power Hammer with the flexibility in stroke of a Hammer in a Mechanic's hand.

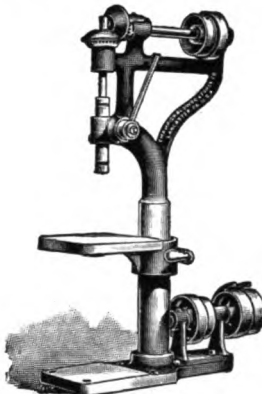

No. 0. Champion Power Bench Drill.

NO. 1 CHAMPION COLUMN GRINDER.

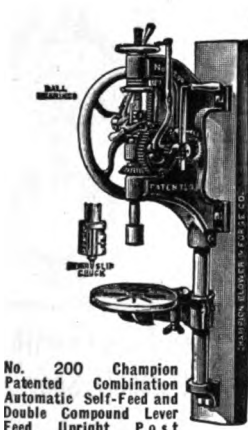

No. 200 Champion Patented Combination Automatic Self-Feed and Double Compound Lever Feed Upright Post Drill.

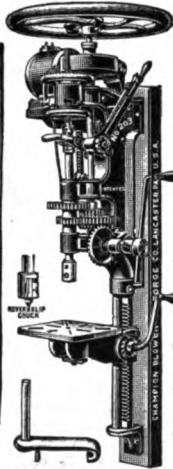

No. 203. Self-Feed and Double Compound Lever Feed, Electrically Driven Post Drill.

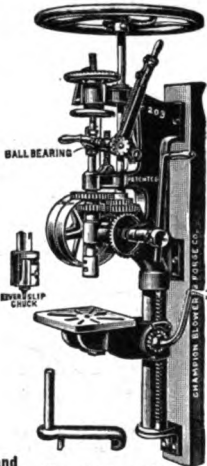

No. 203. Self-Feed and Double Compound Lever Feed Drill.

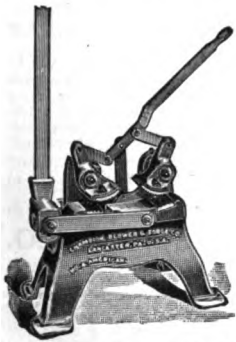

No. 4. AMERICAN TIRE AND AXLE SHRINKER. Will shrink up to 4x1-inch round edge tire, and axle up to 1 1/4 in.

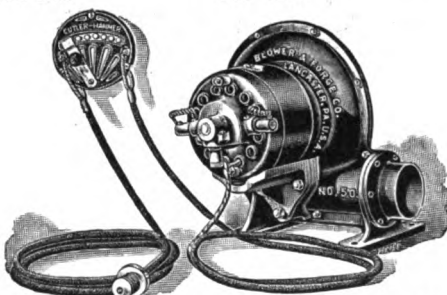

No. 50. Champion-Fire Variable Speed Electric Blacksmith Blower with a Universal Motor for Both Direct and Alternating Current, either 110 or 220 volts, with Detached Rheostat for six speeds, and Steel Pressure Blower Case, for all kinds of general Blacksmith work.

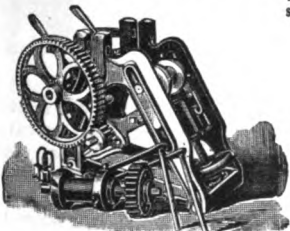

THE CHAMPION "COLUMBIAN" TIRE BENDER. Made in three sizes.



SCREW PLATES IN FOUR STYLES, CUTTING UP TO 1 1/2 IN. Before purchasing a Hand Blower, Forge, Drill Press, Tire Bender, Tire Shrinker, Screw Plate, Power and Electric Blower, Hammer, Punch or Shears, write for our free catalogue, which always shows the greatest variety of improved Blacksmith tools built under one control in the world.



THE CHAMPION THREAD-CUTTING MACHINE. Made in four styles. Cutting from 1/4 to 3/4, or 1/2 to 1 inch. With dies only, or with dies, taps and tap chuck.

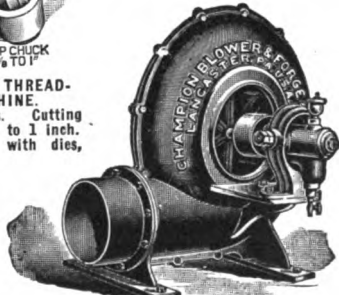

FAN BLOWERS MADE IN SIZES TO 64 INCHES IN HEIGHT

THE CHAMPION BLOWER AND FORGE CO., Lancaster, Pa., U. S. A.





# Appreciation...

WE wish to thank the Horseshoers throughout the United States for the many letters received by us the past year, expressing their appreciation of the interest we have taken in the Horse and our efforts put forth for the breeding of more and better horses. There have been so many letters received that it was not possible for us to answer each one personally and we ask you to kindly accept this acknowledgment.

Our aim in the future will be exactly as it has been in the past—to devote a good share of our time and money to help maintain the supremacy of the Horse in Sport and Industry, and the increase in business we have enjoyed spurs us on to exercise greater energy in this direction for the Year 1917.

We believe the New Year will be a good one and we wish you your share of business and prosperity.

**United States Horse Shoe Co.,  
Erie, Pennsylvania**

## Cushman Light Weight Engines

Built light, built right—for farmers who want an engine to do many jobs in many places, instead of one job in one place. Easy to move around. Very steady and quiet—no jumping, no loud or violent explosions, but smooth running. Throttle Governed. Schebler Carburetor. Friction clutch pulley. Runs at any speed.



**4 H. P. Weighs Only 190 lbs.**

Mounted on light truck, it may be pulled around by hand. Besides doing all regular farm work, it is the original and successful Binder Engine. Saves a team and saves the crop. **8 H. P. only 320 lbs.** Sizes 4 to 20 H. P. Not cheap but cheap in the long run. Engine Book free.

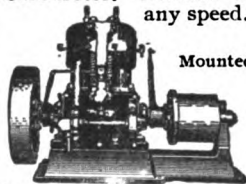

**CUSHMAN MOTOR WORKS,  
907 N. 21st Street, Lincoln, Neb.**

## THE HORSE RASP OF QUALITY



Ask your dealer for the IMPROVED HELLER RASP with keen cutting hard teeth. Made in all patterns and cuts: "Slim," "Light," "Slim Light," and "Fine Cut." Insist on getting the size, kind and cut best suited for your work. It will pay you to give them a trial. New catalogue mailed free on application.

ESTABLISHED IN 1836

**HELLER BROTHERS COMPANY**

**NEWARK, N. J.**

### TRADE LITERATURE AND NOTES.

"Automobile Welding With the Oxy-Acetylene Flame", by M. Keith Dunham, 167 pages; fully illustrated; bound in flexible cloth. Price, \$1.00. Norman W. Henley Publishing Company.

This book by Mr. Dunham details the welding of automobile parts by means of the Oxy-Acetylene flame. It tells how

aluminum, cast iron, steel, copper, brass, and malleable iron are treated. It explains the apparatus that is used, it's care and how to make the necessary shop equipment.

There is also a chapter on the proper manner of burning the carbon out of automobile cylinders, and also an explanation of other uses for Oxygen and Acety-



Front View

Showing Spring Nut Lock applied loose on bolt before being set in place to hold until taken off.

## Why Not Be Sure

that every part of the engine; chassis, or body of the car or other machinery you make or repair will **stay together** until taken apart?

## Spring Nut Locks

are the simplest, surest, safest device to **positively lock** any nut on any bolt. Resists all vibrations. Cannot harm threads. Easily applied. Released whenever desired.

### Cheapest and Best

**Manufacturers, Jobbers, Garage Men, Repair Men and all Dealers should write** for prices on sizes now available. Orders filled in rotation. All sizes by January 1st.

Spring Nut Lock tightened against Nut. Prevents Nut being shaken off and follows Nut tight ening against material.

## Spring Nut Lock Company

653 Transportation Bldg.  
Chicago



Rear View

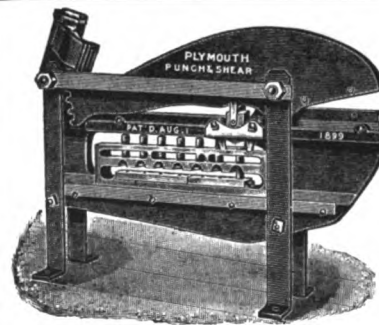

## Every Blacksmith and Repair Shop

should save time, money and hard work by having a

### PLYMOUTH PUNCH AND SHEAR

The only machine that will punch seven different size holes without removing the punches from the machine. Automatic sliding punch rack, no wrench required. Don't accept any other just as good.

Ask your supply house for circular and price or write to the

**PLYMOUTH FOUNDRY & MACHINE CO.  
PLYMOUTH, WIS.**

## KEROSENE Gas Lamps

BURN KEROSENE or GASOLINE one just as well as the other or the two mixed. 300 to 600 C.P. at 1/4 c an hour. Family or Business use.

Write for complete illustrations  
**BRILLIANT GAS LAMP CO.**  
1009 F. So. Wabash Ave., Chicago, Ill.



lene. The chapter on how to figure cost of welding is one of particularly vital interest to the average oxy-acetylene operator, and a careful reading of this chapter alone with an application of the principles set forth should enable the oxy-acetylene operator to get the proper return on his plant investment

A copy of Mr. Dunham's book should be in the hands of every Oxy-Acetylene operator, inasmuch as a great deal of automobile welding and repair work is done by means of the Oxy-Acetylene flame.



CURRENT HEAVY HARDWARE PRICES.

The following quotations are the lowest prices generally prevailing December 20, 1916. They are subject to change without notice, and higher prices are charged according to quality, specification and other conditions.

Iron and steel have made another advance. The price as noted in the proper column is now \$3.85.

Prices on all steel items continue high with further advances in prospect.

Business is generally reported good and a better trade is looked for this coming season. Collections are fair with plenty of opportunity to be better if the trade will make them better.

Table listing prices for Horse Shoes, Steel Shoes, Mule Shoes, and various types of shoeing services.

Table listing prices for Amvils and Merchant Bar Iron.

Table listing prices for Steel Bars and Tee Calks.

Table listing prices for Screw Calks and various types of plow goods.

Table listing prices for Blank Shares, Lanaxide Plates, Lister Lays, and Mould Boards.

Table listing prices for Hickory Lumber.

Table listing prices for Ash and Oak Lumber.

Table listing prices for Yellow Poplar Lumber.

Table listing prices for Rough Hickory Axles.

Table listing prices for Finished Hickory Axles.

Table listing prices for Rough Oak Bolsters.

Table listing prices for Finished Bolsters.

Table listing prices for Rough Oak Wagon Tongues.

Table listing prices for Finished Oak Wagon Tongues.

Table listing prices for Two-Inch Sawed Hounds.

Table listing prices for Wheels.

Table listing prices for Tiring.

Table listing prices for Screws, Rivets, Boring or Boxing, Priming Wheels, Oiling, and Allowance of 25 cents per set.

Table listing prices for Special Tired Wheels.

Table listing prices for Cupped Oak Hubs and Plain End Oak Hubs.

Table listing prices for Rough Sawed Fellos.

Table listing prices for Ironed Poles.

Table listing prices for Ironed Shaft.

Table listing prices for Farm Wagon Bows.

Table listing prices for Standard Size Piano Bodies with Seats.

Table listing prices for Plow Beams.

Table listing prices for Spokes and Rims.

Table listing prices for Wagon Neckpoke Woods.

Table listing prices for Wagon Whiffletree Woods.

Table listing prices for Oval Plow Doubletrees.

Table listing prices for Wagon Evener Woods.

Table listing prices for Buggy Evener Woods.

Table listing prices for Buggy Whiffletree Woods.

Advertisement for 'Do Not Accept Imitations' featuring a large text block and a small image of a Kerosene Engine.

KEROSENE ENGINES. Durable, Powerful, Reliable, Massive. Built to last; to do hard, heavy work. Uses Cheapest Fuel.

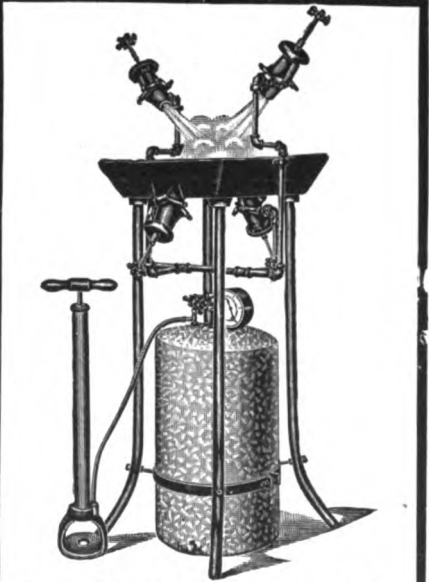

Best Gasoline Brazing Forge IN THE WORLD. Thousands sold in last ten years. Four sizes. Send for catalog.

Advertisement for 'For Replacements... HIGGINS QUALITY SPRINGS' with details about the product and contact information for Higgins Spring & Axle Co.

Advertisement for 'GEARS AND WAGONS' featuring 'Selle Gears' and contact information for THE AKRON-SELLE CO.



# WEBER THROTTLE-GOVERNED KEROSENE ENGINES 4-CYCLE

Lowest Priced Throttle-Governed Engine on the Market—Cash or Payments

Save Half in Fuel. The 1916 model Weber solves the problem of low cost power for all time. Power and speed controlled by throttle, same as steam. No waste of fuel—no violent explosions. Throttle regulates amount of fuel to size of load.

Sold on a Five-Year Guarantee—Two Months' Trial in shop or on farm. Shipped direct from factory at a big saving. FREE BOOK—"How to Use Kerosene" and Engine Folder, sent postpaid. Address

WEBER ENGINE CO.

Dept. 1851

Kansas City, Mo.

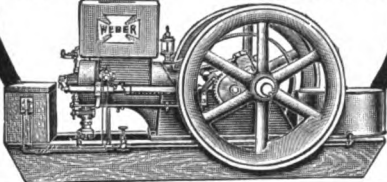

## VETERINARY COURSE AT HOME



Taught in simplest English during spare time. Diploma granted. Cost within reach of all. Satisfaction guaranteed. Have been teaching by correspondence twenty years. Graduates assisted in many ways. Every person interested in stock should take it. Write for catalogue and full particulars. **FREE** London Vet. Correspondence School Dept. 146, London, Ontario, Can.

## Gasoline and Kerosene

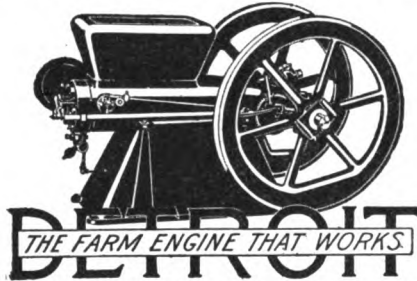

**DETROIT**  
THE FARM ENGINE THAT WORKS

Built and guaranteed by the largest producers of farm engines—simple, durable, powerful—four cycle, suction feed, make and break ignition—every part interchangeable—fully tested. Guaranteed to Develop Rated H. P. **SAVES FUEL, TIME, LABOR, MONEY** Lowest Price, Greatest Value Write for big illustrated Engine Book today Full Line Detroit Engines 2 horsepower up DETROIT ENGINE WORKS 49 Bellevue Ave., DETROIT, MICH. Wadsworth Mfg. Co., Successors

When you write to advertisers in reference to anything advertised here, please mention The American Blacksmith.

Widest Opening

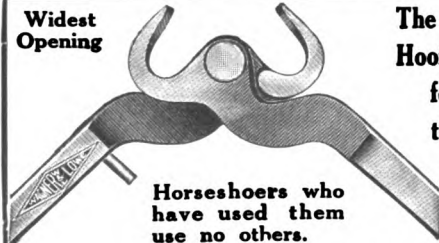

Horseshoers who have used them use no others.

For sale by all leading Jobbers

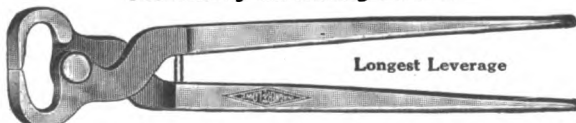

Longest Leverage

The Lowe Manufacturing Co., Enderlin, N. Dak.

The Wagner & Lowe Hoof Nippers are drop-forged from the best tool steel, hand tempered and hand finished throughout.



# Why Pay Double My Price for any Engine?

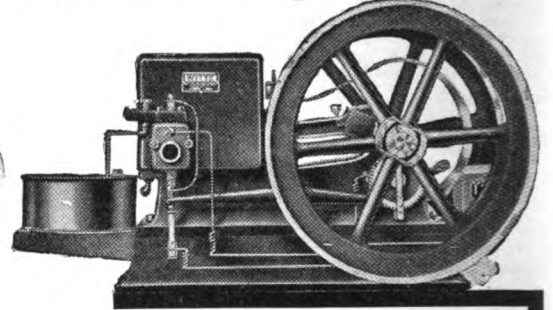

ED. H. WITTE Says:

Put a WITTE Engine on your floor. It will do your work and do it well—I guarantee it. You can have a WITTE, Easy-to-Start Gasoline or Kerosene Engine—plenty of power, low operating expense and a big saving in first cost by ordering from Witte—who operates the largest exclusive engine factory in the world selling direct to the user. Capacity 12,000 perfect engines yearly, or at the rate of 1,000 a month—about 40 a day. WITTE Engines are built by experts, using the latest improved engine machinery. My prices are based on low cost of manufacture, using high grade materials.

## WITTE ENGINES

are built in sizes 2, 3, 4, 6, 8, 12, 16 and 22 H-P.—all sold direct to the user at a big saving—no middlemen or jobbers' profits. I have four definite and easy plans of payment:

- 1st. ALL CASH
- 2nd. PART CASH
- 3rd. BANK DEPOSIT
- 4th. NO MONEY DOWN

I can accommodate any worthy, creditable man as to terms. I allow 90 days trial, and guarantee 5 years. I ship brand new engines, shop tested for power, and crate tested before shipping.

MY FREE BOOK tells all about how WITTE Engines are made, why I sell direct, and why you should own a Witte Engine. Write for Free Book, telling me what size engine you will likely use, or need, if interested in better shop power.—ED. H. WITTE, Pres.

**WITTE ENGINE WORKS** 1768 Oakland Avenue  
Kansas City, Mo.  
1768 Empire Building, Pittsburgh, Pa.

## Do Tire Vulcanizing

The surest and safest way to profit is thru AKRON-WILLIAMS Tire Repair Outfits Used, sold and recommended by more than 60 leading tire companies. Send for Booklet No. 246. THE WILLIAMS FOUNDRY & MACHINE CO. Green Street, Akron, Ohio



## N. Lemoine's Hoof Packing

For Horseshoers Use for packing horses' feet under leather and rubber pads in place of tar. Write for descriptive circular. This circular contains much information of interest to Horseshoers and Horse owners. Address N. LEMOINE CO. Framingham, Mass., U. S. A.

## EMPIRE STEEL WHEELS



Plain or Grooved Tire To Fit Any Wagon

Farm Trucks All Standard Types

Write today for Proposition to Blacksmiths.

Empire Mfg. Co. P. O. Box 306 QUINCY, ILLINOIS

## THERE COMES A TIME IN THE AFFAIRS OF ANVILS



when they simply cease to be useful. Nothing marks the old, unprogressive shop as quickly as a battered and scarred anvil on a rickety base. Put in a new anvil and let your customers know you are keeping your shop up-to-date.

## ARM AND HAMMER WROUGHT IRON ANVILS

have been the desire of experienced Smiths for years because they stand up under the hardest work, expect to be roughly treated, and are made of the right stuff to last long after the ordinary anvil is out of business. Make the acquaintance of an Arm and Hammer Anvil without delay—write and let us give you the details.

THE COLUMBUS ANVIL & FORGING CO. Columbus, Ohio.



### Get Your Share!

More Tuthill Titanic Springs are used for replacement than of all other makes put together. To use Tuthill Titanics for replacement means an increased business for you and a longer list of satisfied customers.

# 3 out of 4 spring breaks are at the Center *TUTHILL TITANIC* *Lubricated SPRINGS*

are guaranteed forever against center breakage and for one year against any breakage.

TUTHILL SPRING CO., 760 Polk St., Chicago, Ill.

## See that Arch

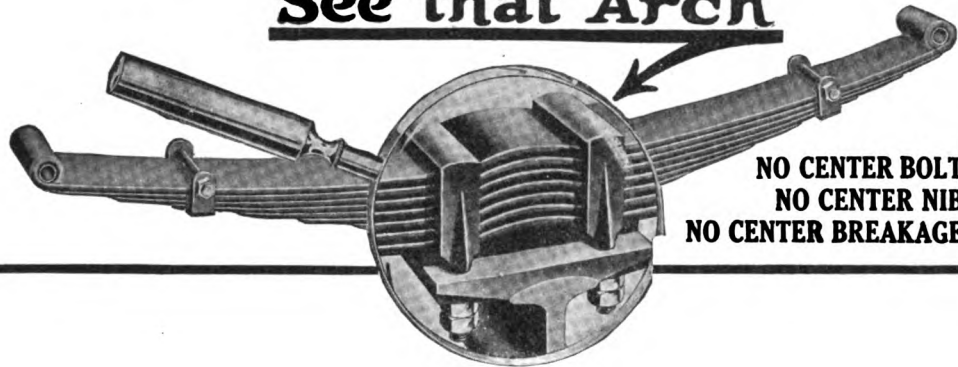

NO CENTER BOLT  
NO CENTER NIB  
NO CENTER BREAKAGE

Size	Ounces
No. 0	10
" 1	12
" 2	15½
" 3	19
" 4	23½
" 5	29
" 6	33½
" 7	39
" 8	46



Front

SAMPLES  
FREE UPON  
REQUEST

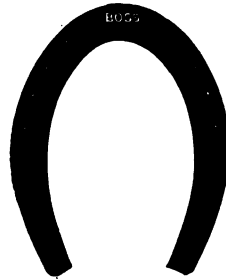

Hind

## LIGHT

Size	Ounces
No. 0	8½
" 1	11
" 2	13½
" 3	16
" 4	20
" 5	24
" 6	28
" 7	34½
" 8	40½

Manufactured by the  
**BRYDEN HORSE  
SHOE COMPANY**  
—  
CATASAUQUA,  
PENNA.

# BOSS SNOW SHOES

Manufacturers of a Larger  
Variety of

## HORSE and MULE SHOES

Than Any Other Concern  
in the World.

Size	Ounces
No. 1	12
" 2	14
" 3	17
" 4	20
" 5	25
" 6	30
" 7	35½



Front

## EXTRA LIGHT

SEND FOR  
CATALOG  
DESCRIBING  
OUR FULL LINE

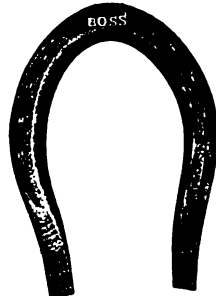

Hind

Size	Ounces
No. 1	9½
" 2	11
" 3	14
" 4	17½
" 5	21
" 6	25
" 7	30½

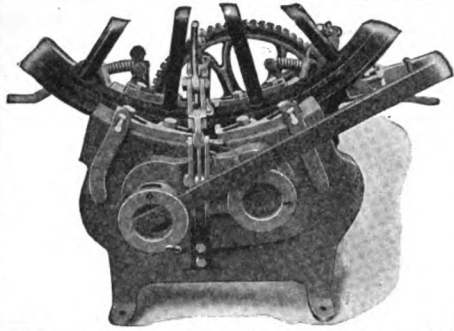

### The Brooks Cold Tire Setter

Sets tires cold on the wheel and is the pioneer edge-grip hand-power cold tire setter. Used and officially endorsed by the United States Government in the Department of War and Interior. Thousands of blacksmiths in the U. S. consider it the most profitable machine in their shop. We build both hydraulic and lever cold tire setters. The Brooks does the work quicker and better than any other cold tire setter on the market and should be in every blacksmith and carriage repairer's shop. Write for catalog and prices.

We are also manufacturers of the latest improved Oxy-Acetylene Welding machines and generators, equipped with our famous Safety Flash Back Valve. It prevents explosions.

We also build Welding Outfits to be used with cylinder gases.

Our catalog will interest you and is free for the asking.

The Brooks Machine Company, Wichita, Kansas



Bench Jointers 5 and 7 in. Complete Hand Planers or Jointers 5 in. to 13 in. Complete Combined machine Jointers and Saw arborers or pole rounding heads with numerous other attachments for wood frame tables 5 to 13 in. Circular and square style cutter heads for wood frame tables 5 to 17 in. Special cutter heads and knives any style or length. Write at once for catalogue No. 12 illustrating the full line of machines we make for the wood shop.

W. L. Sherwood, Kirksville, Mo.

## A Big Threefold Offer!

### Read Every Word—It May Not Come Again

I want to make you a personal gift of that delightful book, "The Story of Kate and Queen" (price 50 cents)—the greatest horse story since "Black Beauty." You can also have free my Introductory Course in Horse Training, the result of twenty years' experience making bad horses good, and worth more.

Both these valuable gifts are yours with the famous Beery Breaking Bridle, with which you can cure a horse that Bites, Strikes, is Bad to Shoe, Lead, Groom, Bridle, Harness, etc.; also fine for Stallions.

### 10 Days' Free Trial—Beery Breaking Bridle

The price of the bridle is \$1.50. Send me just that amount, and I'll send you the bridle, "The Story of Kate and Queen," and my Introductory Course. I'll pay all shipping charges. Use the bridle to your heart's content for ten days. If you like it, keep it. If not, just send everything back at my expense, and I'll return your money. You risk nothing—lose nothing. Write today while the offer holds good. Ask for free hints on training a horse with a bad habit, when sending for a bridle. Write now—right NOW!

Prof. Jesse Beery, Box 428, Pleasant Hill, Ohio



Pat. Applied For



### DEATH TO HEAVES! NEWTON'S

STANDARD REMEDY FOR HEAVE, COUGH, DISTEMPERS AND INDIGESTION CURE. Cures Heaves by correcting the cause—Indigestion. Prevents Cough, Staggings, etc. Best Conditioner and Worm Expeller. Used by Veterinarians for 30 years. The first or second \$1.00 can cures heaves. The third can is guaranteed to cure or money refunded. \$1.00 per can at dealers' or sent direct postpaid. Booklet free. THE NEWTON REMEDY COMPANY, Toledo, Ohio.

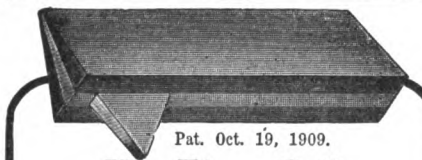

Pat. Oct. 19, 1909.

### Use These Self Sharpening Toe Calks

Ludvigsen Bros. Welded Steel Center Calks are the choice of MANY horseshoers because they always give satisfaction.

THE HARD STEEL PLATE in the center and the two outside plates are welded together and shaped to a sharp calk that stays SHARP while it WEARS DOWN.

Sizes, 0 to 6.

We will gladly mail a sample of this calk to any reader of The American Blacksmith on request. BE SURE TO TELL YOUR JOBBER you want LUDVIGSEN BROS. WELDED STEEL CENTER TOE CALKS.

LUDVIGSEN BROS., JACKSON, MINN.,

or 47 Second St., MILWAUKEE, WIS.

## WONDER DISC SHARPENERS

SAVE 1/2 THE TIME AND ALL THE LABOR

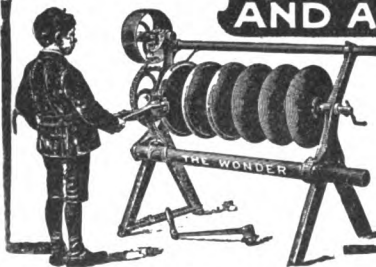

THE WONDER is the only machine adjusted to all conditions.

- Can shear any part of edge to any bevel.
- Can shear back from edge as far as required.
- Can use tool on either side of disc.
- Can shift from one disc to another.

Can do all this without the turn of a set screw or nut, is a positive feed, automatically adjusts itself to wobbling or bent discs; knives made of best grade self-tempered steel; will last a lifetime; for hand and power. For prices, write to your jobber or

A. E. DURNER, Manufacturer

Main Office: Evansville, Wisconsin, U. S. A. Made in Evansville, Wis., and Brandon, Man., Canada.

known from coast to coast in horse circles. At first glance the average shoer will say, "Well what good does this do me" and the question is but a natural one.

However, it does do the shoer good and in this way. Every man or body of men who either breed or raise race horses is doing his share toward keeping up the general interest in the horse, whether it be for commercial purposes or pleasure alone, and no one will take the trouble to deny the fact that if tomorrow men would quit breeding horses of all kinds and other men would quit racing them and exhibiting them in the show ring, the horse shoeing business would go on the rocks and be torn to pieces.

Therefore the stand of the United States Horse Shoe Company is a just one

and the shoer who purchases their product not alone does himself a kindness in the way of getting the best shoes on the market but also helps a concern that is spending some of its profit in an earnest endeavor to keep the horse game alive and kicking.

Think this over, Mr. Shoer, and see if we are not right.

The L. S. P. Calking Machine Company wishes to announce at this time that their 1917 Model will be the same as the 1916, as they find they can make no change in the machine which will improve it. Although the machine is costing much more to make than it did some time ago, as yet they have made no advance in price.

Continued on page 48.

### TRADE LITERATURE AND NOTES.

#### FOR THE GOOD OF THE GAME

It is a remarkable fact but nevertheless true that of all the concerns engaged in the manufacture and sale of horse shoes, the United States Horse Shoe Company, of Erie, Pa., is the only one that is doing anything directly or indirectly to stimulate the horse industry.

For several years past this enterprising Pennsylvania company has maintained a pretentious racing stable which through the performances of Lou Jennings, 2:06 3/4 and many other fast ones, has become



CURRENT HEAVY HARDWARE PRICES.

Advances will be noted in a number of items this month. Shoes have gone up another notch to \$5.75— with an advance to \$1.15 and \$1.16 on Anvils—a climb to \$4.00 on Iron and Steel—and for Calks now at \$1.90 and \$2.15. There seems to be no limit yet in sight.

Business is generally reported excellent with seasonal work in good demand. The weather is placing sled and sleigh work in demand and this goes a long way toward making up a good, full day for the general shop.

Collections are reported as good in some sections while there are localities where they seem somewhat slow.

Horse Shoes— All Iron Shoes \$5.75 Steel Shoes 5.75 No. 0 and No. 1, 25 cents extra. 15 cents per keg additional charged for packing more than one size in a keg. Mule Shoes X. L. Steel Shoes Countersunk Steel Shoes \$6.55 Tip Shoes Goodenough, heavy Goodenough, sharp Toe Weight, pr. .25 Side Weight, pr. .25 E. K. Light Steel Steel Driving O. O. Mule Shoes, extra

Anvils \$1.15 & .16

Merchant Bar Iron— \$4.00 rates, full extras, and 20 cents per 100 pounds extra for broken bundles.

Steel Bars— \$4.00 rates, full extras.

Toe Calks— Per Box Blunt \$1.90 Sharp 2.15

Screw Calks— 5-16 7-16 1/2 3/4 Blizzard M. \$20.00 \$20.00 \$22.00 \$22.00 \$24.00 Sure Grip M. 20.00 20.00 22.00 24.00 24.00 Bl. Diamond M. 20.00 20.00 22.00 24.00 24.00 Red Tip M. 22.00 22.00 24.00 24.00 26.00 Rowe, Jr., M. 20.00 20.00 22.00 22.00 24.00 King Tip M. 22.00 22.00 24.00 24.00 26.00

Plow Goods— Soft Solid Crucible Blank Shares \$1.18 \$1.23 \$1.18 1/2 Lanamide Plates .18 .12 1/2 .18 1/2 Lister Lays—Triangle .22 .16 .17 Lister Lays—V-Pattern .26 .16 1/2 .17 1/2 Lister Mould Boards .21 .13 1/2 .14 1/2 Cult. Shov. Blanks (5x5-1/2x10 1/2) .20 .13 .15

Hickory Lumber—Per Foot— 1 to 2 1/2 \$ .10 1 1/2 to 4 1/4 .12

Ash and Oak Lumber—Per Foot— 1 to 1 1/2 \$ .08 2 1/2 to 3 \$ .09 1 1/2 to 2 .08 1/2 3 1/2 to 4 .10

Yellow Poplar Lumber, Per M. Feet— 6 to 12 18 to 17 18 to 24 1/2 \$75.00 \$75.00 \$85.00 1/2 \$75.00 \$75.00 \$85.00 3/4 \$78.00 \$85.00 \$95.00 1/2 \$85.00 \$90.00 \$114.00 3/4 \$85.00 \$90.00 \$114.00

Rough Hickory Axes— 3 x 4 x 6 ft. \$ .70 3 1/2 x 4 1/2 x 6 ft. .95 4 x 5 x 6 ft. 1.20 5 x 6 x 6 ft. 2.25 4 x 5 x 6 1/2 ft. 1.75 4 1/2 x 5 1/2 x 7 ft. 2.30 5 x 6 x 7 ft. 2.80 5 x 7 x 7 ft. 3.40

Finished Hickory Axes— For 2 1/2 and 2 3/4 Skeins \$ .95 For 3 Skeins 1.38 For 3 1/2 Skeins 1.48 For 3 3/4 Skeins 1.68 For 3 1/2 Skeins 1.90 For 4 Skeins 2.10

Rough Oak Bolsters— 3 x 4 \$ .86 3 1/2 \$ .40 1 1/2 \$1.80 1 1/4 \$1.55 1 1/2 \$1.75 4 x 4 .80 4 1/2 2.20 2.55 3.00 5 x 6 1.00 1.30

Finished Bolsters— 2 1/2 and 3 1/2 56c 3 1/2 65c 3 3/4 92c

Rough Oak Wagon Tongues— 4 x 4, 2 x 4 12 and smaller \$1.15

Finished Oak Wagon Tongues— 3 1/2 and smaller \$1.35 3 3/4 1.45 4 1.55

Two-Inch Sawed Hounds— Per Pair Tongues 38c Front 44c Hind 55c

Wheels— 0 to 71 inch. A. & B. Grades 50-5% C. Grades 45-5% D. Grades 45%

Tiring—1 1/2 x 1/2 stocks 20% 1 1/2 x 1/2 factory 25%

Screws—1 1/2 Thread and less 27 1/2% Rivets—1 1/2 Thread and less 27 1/2%

Boring or Boxing less than 10 cents lots 40% Boring or Boxing 10 sets or more of one size 60% Priming Wheels, net 25c Oiling, not tired, set 20c Allowance of 25 cents per set on all special tired wheels with three or four piece rims. Oiling, not tired, No. 17 to No. 89 25c Oiling No. 45 and larger 40c

Special Tired Wheels—"F" Grade—3 or 4 piece Rim— 0 1/2 x 1 1/2 \$8.80 9 1 1/2 x 1 1/2 \$11.57 1 1/2 x 1 1/2 8.99 9 1 1/2 x 5-16" 12.48 3 1 x 1 1/2 9.55 18 1 1/2 x 5-16" 14.78 8 1 x 5-16" 10.40 18 1 1/2 x 1 1/2 15.75

Cupped Oak Hubs— 10 x 14 \$3.80 11 x 14 4.20 11 x 15 4.50 11 x 16 5.10 12 x 16 5.75 12 x 17 6.30 13 x 18 7.00

Pisin End Oak Hubs— 7 x 8 x 9 \$1.80 7 x 9 x 10 1.50 8 x 9 x 10 1.55 8 x 10 x 11 1.80 9 x 10 x 11 1.95 9 x 11 x 12 2.00 10 x 12 x 13 2.00 10 x 13 x 14 2.30 11 x 13 x 14 4.30 12 x 14 x 15 5.10

Rough Sawed Fellos— 1 1/2 x 3 1/2 \$1.65 2 x 3 1/2 \$1.85 1 1/2 x 3 1/2 1.75 2 1/2 x 3 1/2 3.50 1 1/2 x 3 1/2 1.85 2 1/2 x 3 1/2 5.25 3 x 3 1/2 \$5.75

Ironed Poles, White, XXX 1 1/2 x 2 1/2 No. 2 \$5.50 2 x 2 1/2 No. 3 5.50

Ironed Shaft, White, XXX— 1 1/2 x 2" and smaller \$2.50 1 1/2 x 2" 2.75 1 1/2 x 3 1/2 3.55

Farm Wagon Bows— Round Top, 1/2 x 2" \$ .60 Flat Top, 1/2 x 2" .75 Round Top, 3/4 x 2 1/2 1.85

Standard Size Piano Bodies with Seats— Each \$5.00

Plow Beams— 1 Horse \$ .60 2 Horse .85 3 Horse 1.20

Spokes and Rims— Oak and Hickory Spokes, 50% on Weils & Leab List No. 8. Finished Rims—XX—1 1/2 \$1.75 Finished Rims—XX—1" 1.65 Oak Rims—Discounts 40-10% Hickory Rims 40%

Wagon Neckpoke Woods— Keller & Tamm's List—Discount 25%

Wagon Whiffletree Woods—All Grades— Keller & Tamm's List—Discount 25%

Oval Plow Doubletrees— Flat Plow Doubletrees— 2 1/2 x 26" \$1.80 1 1/2 x 2 1/2 x 42" \$2.75 2 x 40" 2.40

Wagon Evener Woods— 2 x 4 and 2 x 4 1/2—Keller & Tamm's List— Discount 20% Larger 25%

Buggy Evener Woods—All Grades Keller & Tamm's List—Discount 25%

Buggy Whiffletree Woods— Mixed Second Growth and Second Growth— Keller & Tamm's List—Discount 25%

Buggy Neckpoke Woods—All Grades Keller & Tamm's List—Discount 25%

United Profit-Sharing Coupons

are packed in each carton of Rowe Calks

That's extra value for the smith. But the real value of Rowe Calks is that they make satisfied customers.

THE ROWE CALK COMPANY, PLANTSVILLE, CONN.

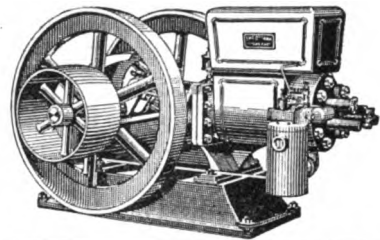

OTTAWA ENGINES

Kerosene Oil, Gasoline and Gas

Let me send you an engine to earn its own cost while you use it—for my Kerosene engine gives more power from a gallon of 6-cent kerosene than you can get from a gallon of 20 or 25-cent gasoline in any gasoline engine—Easy to start; easy to operate; no cranking; no batteries.

You Don't Have To Pay War Prices! 2 H-P. \$33.95 5 H-P. \$ 74.95 12 H P. \$191.50 3 H-P. 51.50 7 H-P. 101.50 16 H-P. 265.50 4 H-P. 69.75 10 H-P. 144.50 22 H-P. 369.90

Other sizes—Portable and Saw-Rigs at proportionally low prices. F. O. B. Factory.

DIRECT FROM MY BIG FACTORY

For longer than any other engine manufacturer in America, I have been selling engines direct from the factory to the man in the shop or on the farm. Now, as before, any honest man can have my engine on

90 DAYS' TRIAL Every engine I send out must make good all I guarantee. No need to pay double my price for any good engine, or take an out-of-date engine for any kind of a price. Let me show you how to figure what an engine is worth and

How To Know Better Engines My newest book helps you choose a safe and value-received engine—How to make simple tests—and all about valves in head motor. Send me your address today. Just a postal card will bring this newest and latest book.

Geo. E. Long, OTTAWA MFG. CO. 1797 King St., Ottawa, Kansas.



Best Gasoline Brazing Forge IN THE WORLD

Thousands sold in last ten years. Four sizes. Send for catalog. The National Rubber & Specialties Co. 4433-39 Chickering Ave., Winton Place, Cincinnati, Ohio.

FUDEN'S MECHANICAL TABLES

SAVE ALL FIGURING! Tell at a glance how much stock to use for oval or elliptical hoops of any size, the circumferences of circles, weight of flat, square and round stock, and the weight and strength of ropes and chains. Should be in every progressive Smith's hands. Bound very neatly in green cloth. Price, 50c. AMERICAN BLACKSMITH COMPANY, Buffalo, N.Y.

"GEARS AND WAGONS"

Selle Gears A quarter of a century of success has placed "Selle Gears" and Wagons in the hands of the largest wagon users in the world. Express and Transfer Companies, Department Stores, Fire Departments, etc.; specify "Selle Gears" and will take no other after once tried. 230 page catalog free THE AKRON-SELLE CO. Akron, Ohio



# WEBER THROTTLE-GOVERNED KEROSENE 4-CYCLE ENGINES

Lowest Priced Throttle-Governed Engine on the Market—Cash or Payments

Save Half in Fuel. The 1916 model Weber solves the problem of low cost power for all time. Power and speed controlled by throttle, same as steam. No waste of fuel—no violent explosions. Throttle regulates amount of fuel to size of load.

Sold on a Five-Year Guarantee—Two Months' Trial in shop or on farm. Shipped direct from factory at a big saving. FREE BOOK—"How to Use Kerosene" and Engine Folder, sent postpaid. Address

**WEBER ENGINE CO.**

Dept. 1851 Kansas City, Mo.

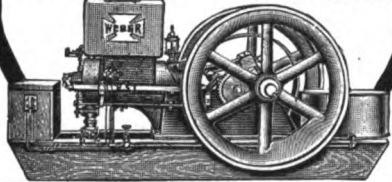

## VETERINARY COURSE AT HOME



Taught in simplest English during spare time. Diploma granted. Cost within reach of all. Satisfaction guaranteed. Have been teaching by correspondence twenty years. Graduates assisted in many ways. Every person interested in stock should take it. Write for catalogue and full particulars - - - **FREE** London Vet. Correspondence School Dept. London, Ontario, Can.

## EMPIRE STEEL WHEELS



Plain or Grooved Tire To Fit Any Wagon Farm Trucks All Standard Types Write today for Proposition to Blacksmiths. Empire Mfg. Co. P. O. Box 307 QUINCY, ILLINOIS

## TRADE LITERATURE AND NOTES.

Continued from page 42.

This model machine has been on the market a year and a half and the universal approval which it has met with by its users has more than exceeded the expectations of its manufacturers. The sales of the machine are so extremely good that they are keeping the factory running overtime to fill the orders.

Model T Ford Car, Its Construction, Operation and Repair, by Victor W. Page. 305 pages, over 100 specially made engravings, and two large folding plates. Bound in cloth, price, \$1.00. Norman Henley Pub. Co.

This is the new 1917 edition of this popular book, written by Mr. Page. This book contains complete and practical instructions for the construction, operation and repair of the Ford car. While Ford drivers and owners will find this book just filled with information for them, the automobile repairman will also find this volume of extreme worth and practical value. No detail of the Ford mechanism is omitted, every part of the car from radiator to tail lights and from top to tires receives proper and thorough attention. The book is free from highly technical terms and the text is easily understood. The illustrations make all operations very clear. The great number of Ford cars being sold every year, makes it almost necessary that the automobile repairman have one of these books in his library.



# Why Pay Double My Price for any Engine?

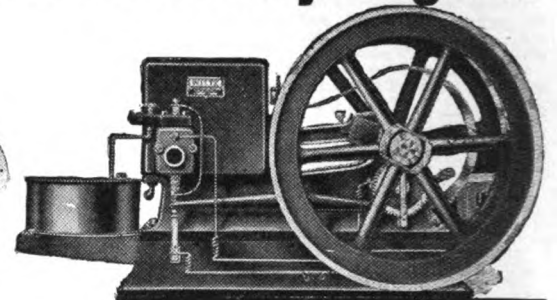

ED. H. WITTE Says:

Put a WITTE Engine on your floor. It will do your work and do it well—I guarantee it. You can have a WITTE, Easy-to-Start Gasoline or Kerosene Engine—plenty of power, low operating expense and a big saving in first cost by ordering from Witte—who operates the largest exclusive engine factory in the world selling direct to the user. Capacity 12,000 perfect engines yearly, or at the rate of 1,000 a month—about 40 a day. WITTE Engines are built by experts, using the latest improved engine machinery. My prices are based on low cost of manufacture, using high grade materials.

## WITTE ENGINES

are built in sizes 2, 3, 4, 6, 8, 12, 16 and 22 H-P.—all sold direct to the user at a big saving—no middlemen or jobbers' profits. I have four definite and easy plans of payment:

- 1st. ALL CASH
- 2nd. PART CASH
- 3rd. BANK DEPOSIT
- 4th. NO MONEY DOWN

I can accommodate any worthy, creditable man as to terms. I allow 90 days trial, and guarantee 5 years. I ship brand new engines, shop tested for power, and crate tested before shipping.

MY FREE BOOK tells all about how WITTE Engines are made, why I sell direct, and why you should own a Witte Engine. Write for Free Book, telling me what size engine you will likely use, or need, if interested in better shop power.—ED. H. WITTE, Pres.

**WITTE ENGINE WORKS** 1768 Oakland Avenue Kansas City, Mo. 1768 Empire Building, Pittsburgh, Pa.

## "NEW EASY" 4 Sizes BOLT CLIPPERS "EASY" 2 Sizes

THE GENUINE TOOL



KNOWN AND PREFERRED EVERYWHERE

H. K. PORTER

EVERETT, MASS.

U. S. A.

## THE HORSE RASP OF QUALITY



Ask your dealer for the IMPROVED HELLER RASP with keen cutting hard teeth. Made in all patterns and cuts. "Slim," "Light," "Slim Light," and "Fine Cut." Insist on getting the size, kind and cut best suited for your work. It will pay you to give them a trial. New catalogue mailed free on application.

ESTABLISHED IN 1836

HELLER BROTHERS COMPANY

NEWARK, N. J.

## Butterfield's Screw Plates

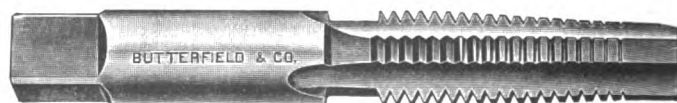

We do not claim to be the oldest manufacturers of Screw Plates. We are not sure that this is any distinction.

Our claims for the superiority of our TAPS and SCREW PLATES are based on actual performance. The rapid growth of our business, is proof positive of the excellence of our product.

Be sure you ask for BUTTERFIELDS, and take no substitute.

NEW YORK STORE 126 Chambers Street

BUTTERFIELD & CO. DERBY LINE, VT., U.S.A.



# Written for You

## Just Write Us Today for Your Copy The Booklet Tells:



**Why springs break**—and why 75 out of every 100 break at the center.  
**How springs can be kept from breaking**—and how Tuthill Titanics are used for more replacements than all other makes put together. They're guaranteed forever against center breakage and for one year against breakage at any point.  
 Springs are important. Your car is no stronger, no safer than its springs. The book tells how to dodge danger, annoyance, expense. Get it. Read it.

## TUTHILL LUBRICATED TITANIC SPRINGS

**No Center Bolt** which practically cuts the spring in two at the very point where greatest strain comes.  
**No Center Nib** where the weakening center hole in the short leaf spring is even larger than in the center bolt type.  
**No Center Breakage** for the Arch *strengthens* the spring at the center, and Titanic Springs are guaranteed forever against center breakage.

Tuthill Spring Co., 760 Polk Street, Chicago

### See that Arch

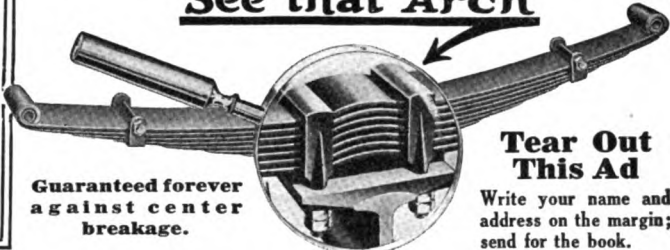

Guaranteed forever against center breakage.

### Tear Out This Ad

Write your name and address on the margin; send for the book.

### Finest Possible Delivery Service

The Tuthill Spring Co. is known as favorably for its deliveries and service as the quality of its springs. Sixty distributors. Your distributor always is ready to make immediate shipment. His orders to us are filled the same day received. OUR NEW 1917 PRICE LIST is the most complete price list of springs ever published.

Send for your copy of the booklet today

Size	Ounces
No. 0	10
" 1	12
" 2	15½
" 3	19
" 4	23½
" 5	29
" 6	33½
" 7	39
" 8	46



Front

SAMPLES FREE UPON REQUEST

## LIGHT



Hind

Size	Ounces
No. 0	8½
" 1	11
" 2	13½
" 3	16
" 4	20
" 5	24
" 6	28
" 7	34½
" 8	40½

Manufactured by the  
**BRYDEN HORSE SHOE COMPANY**  
CATASAUQUA, PENNA.

# BOSS SNOW SHOES

Manufacturers of a Larger Variety of  
**HORSE and MULE SHOES**  
Than Any Other Concern in the World.

Size	Ounces
No. 1	12
" 2	14
" 3	17
" 4	20
" 5	25
" 6	30
" 7	35½



Front

## EXTRA LIGHT

SEND FOR CATALOG DESCRIBING OUR FULL LINE

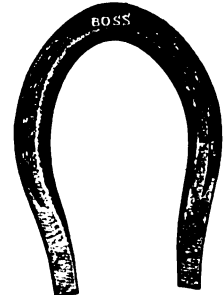

Hind

Size	Ounces
No. 1	9½
" 2	11
" 3	14
" 4	17½
" 5	21
" 6	25
" 7	30½



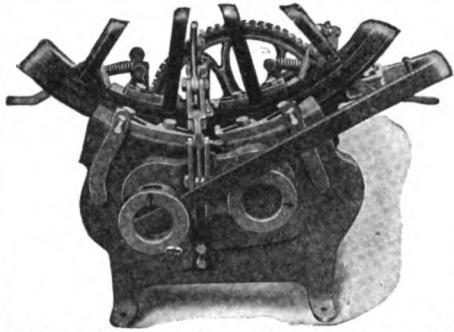

## The Brooks Cold Tire Setter

Sets tires cold on the wheel and is the pioneer edge-grip hand-power cold tire setter. Used and officially endorsed by the United States Government in the Department of War and Interior. Thousands of blacksmiths in the U. S. consider it the most profitable machine in their shop. We build both hydraulic and lever cold tire setters. The Brooks does the work quicker and better than any other cold tire setter on the market and should be in every blacksmith and carriage repairer's shop. Write for catalog and prices.

The Brooks Machine Company,

Wichita, Kansas

We are also manufacturers of the latest improved Oxy-Acetylene Welding machines and generators, equipped with our famous Safety Flash Back Valve. It prevents explosions.

We also build Welding Outfits to be used with cylinder gases.

Our catalog will interest you and is free for the asking.

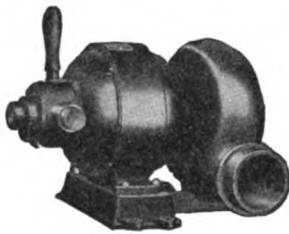

## "KAZOO" Variable Speed BLOWER

We are willing to convince you that this is the best blower on the market.

Write for full information.

R. P. WARNER ELECTRIC COMPANY  
KALAMAZOO, MICHIGAN

## Never Accept Imitations

When a dealer or jobber tries to impose substitutes for the *good advertised articles*, write us or the manufacturer. We will see that you get the genuine—what you want.

## VULCANIZERS

Free Instructions and Book with each outfit at Factory or by Mail.

COMPLETE LINE  
Tire Vulcanizers, Wrapping Machines and Many Useful Devices for Tire Shops and Factories.  
64-PAGE CATALOG ON REQUEST

1894 Established 22 Years 1916

CHAS. E. MILLER  
Anderson Rubber Works  
Factory and Office  
Anderson, Ind., U. S. A.

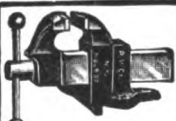

Prentiss  
Patent Vises  
BEST MADE

Large Illustrated Catalog Free

Prentiss Vise Co., Hardware Bld., New York

### TRADE LITERATURE AND NOTES.

"The Automoblist Pocket Companion And Expense Record" arranged by Victor W. Page. 169 pages, 7 $\frac{3}{4}$ x5 inches in size, leatherette cover. Price \$1.00 or 4/6. Norman Henley Pub. Co., New York City.

This latest book by Mr. Page is for the practical automobile operator, who wishes to keep accurate records of his operating expenses. It contains ruled pages for entering the figures, showing the miles covered during each day of the year, the fuel cost and the cost of repairs. It answers such important questions as—How many miles per gallon of fuel? How long do tires last? What did the car actually cost? Is repair expense unreasonable? Do tires wear out too fast?

In addition to the ruled pages, it also contains much information of value to the

motorist, including a complete digest of auto laws of all states, a lubrication schedule, hints and kinks for the care of tires, of batteries, etc., also many useful tables and receipts of interest to all motorists.

This book should be in the tool kit of every motor car, whether it be a flivver, or a twelve-cylinder.

We wish to call our readers' attention to the advertisement of the Haywood Tire and Equipment Co., in this issue—manufacturers of complete tire repair equipment which many shop owners are putting in and making large profits handling this class of work.

The Haywood Co., offer to teach our readers the tire repair business thoroughly either at their free training school in Indianapolis or by mail.

It is estimated that during 1917 over thirty million tires will be in use and every one of them needs repairing at some time, so that the demand for tire repair work is already established and all the shop owner has to do is to secure the equipment and knowledge necessary to repair these tires at excellent profits.

The Haywood line of equipment includes machines of all sizes at reasonable prices.

Mr. M. Haywood, president of this company, will be glad to send to any reader of the AMERICAN BLACKSMITH on request, his free book, "The Up Grade Road to Wealth," and we would suggest if you are interested in a new and profitable business that you write for a copy of this book.

With the rapid development in the welding of metals, there has arisen a need for many accessories, prominent among which is a handy, compact, and thoroughly effective device for heating large castings previous to the actual welding process.

This is known technically as "pre-heating," and its special requirements have been effectively met by the Hauck Welded Steel, Kerosene Torches.

Their use for this purpose is a distinct advance over the old-time dangerous and expensive gasoline torch and is of particular value in the sections plentifully supplied with kerosene, but lacking in gasolene.

Moreover, manufacturers claim it will handle heating jobs impossible with any other type of torch. They recommend it particularly for the following uses:—general welding and brazing, in power plants, engine rooms, machine shops, railroad shops, ship yards, dry docks and on board ships.

The manufacturers will gladly give full information to interested parties.

Address Hauck Manufacturing Company, 140 Cedar St., New York City.

Imperial Welding and Cutting Book, 56 Pages—Illustrated—Cloth, \$1.00 (4/6). Imperial Brass Mfg. Co., Chicago.

This book on the subject of oxy-acetylene welding and cutting is intended primarily for users of Imperial welding equipment but the user of any oxy-acetylene torch will find a great deal of practical information in it. The book naturally covers the elementary details of oxy-acetylene torch manipulation and gives the beginner just the information he needs. Expansion and contraction are explained and preheating and cooling are also detailed. The excellent illustrations and clear explanations should make all operations clear and distinct to the merest novice. The book is an excellent addition to the instructive literature on oxy-acetylene torch manipulation.



**CURRENT HEAVY HARDWARE PRICES.**

The following quotations are the lowest prices generally prevailing February 1, 1917. They are subject to change without notice, and higher prices are charged according to quality, specification and other conditions.

Advances will be noted in a number of items this month. Shoes have gone up another notch to \$5.75—with an advance to \$1.15 and \$1.16 on Anvils—a climb to \$4.00 on Iron and Steel—and for Calks now at \$1.90 and \$2.15. There seems to be no limit yet in sight.

Business is generally reported excellent with reasonable work in good demand.

Collections are reported as good in some sections while there are localities where they seem somewhat slow.

<b>Horse Shoes—</b>	
All Iron Shoes	\$5.75
Steel Shoes	5.75
No. 0 and No. 1, 25 cents extra.	15 cents per keg additional charged for packing more than one size in a keg.
<b>Mule Shoes—</b>	
X. L. Steel Shoes	
Countersunk Steel Shoes	\$6.55
Tip Shoes	
Goodenough, heavy	
Goodenough, sharp	
Toe Weight, pr.	.25
Side Weight, pr.	.25
E. E. Light Steel	6.80
Steel Driving	
O. O. Mule Shoes, extra	

Anvils .....\$1.15 & .16

**Merchant Bar Iron—**  
\$4.00 rates, full extras, and 20 cents per 100 pounds extra for broken bundles.

**Steel Bars—**  
\$4.00 rates, full extras.

<b>Toe Calks—</b>	
Blunt	Per Box
Sharp	\$1.90
	2.15

<b>Screw Calks—</b>	
5-16	7-16
Blizzard M	\$20.00 \$20.00 \$22.00 \$22.00 \$24.00
Sure Grip M	20.00 20.00 22.00 22.00 24.00
Bl. Diam. M	20.00 20.00 22.00 24.00 24.00
Red Tip M.	22.00 22.00 24.00 24.00 26.00
Rowe, Jr. M	20.00 20.00 22.00 22.00 24.00
Ring Pt. M.	22.00 22.00 24.00 24.00 26.00

<b>Flow Goods—</b>	
	Soft Solid
	Center Cast Crucible
Blank Shares	\$.18 \$.12 1/2 \$.18 1/2
Landside Plates	.18 .12 1/2 .13 1/2
Lister Lays—Triangle	.28 .15 .17
Lister Lays—V-Pattern	.26 .15 1/2 .17 1/2
Lister	.17 1/2
Mould Boards	.21 .13 1/2 .14 1/2
Cult. Shov. Blanks (5x5-1/2x10 1/2)	.20 .13 .15

<b>Hickory Lumber—Per Foot—</b>	
1 to 2 1/2	\$.10
1 1/2 to 4 1/2	.12

<b>Ash and Oak Lumber—Per Foot—</b>	
1-1 1/4	\$.08
1 1/4-2	.08 1/2

<b>Yellow Poplar Lumber, Per M. Feet—</b>	
6 to 12	18 to 17
18 to 24	
3/4"	\$75.00 \$75.00 \$85.00
1/2"	78.00 78.00 90.00
3/8"	78.00 85.00 95.00
1/4"	85.00 90.00 114.00
3/16"	85.00 90.00 114.00

<b>Rough Hickory Axles—</b>	
3 x 4 x 6 ft.	\$.70
3 1/2 x 4 1/2 x 6 ft.	.95
4 x 5 x 6 ft.	1.20
5 x 6 x 6 ft.	2.25
4 x 5 x 6 1/2 ft.	1.75
4 1/2 x 5 1/2 x 7 ft.	2.80
5 x 6 x 7 ft.	2.80
5 x 7 x 7 ft.	3.40

<b>Finished Hickory Axles—</b>	
For 2 1/2 and 2 3/4 Skeins	\$.95
For 3 Skeins	1.38
For 3 1/2 Skeins	1.48
For 3 3/4 Skeins	1.63
For 4 Skeins	1.90
For 4 1/2 Skeins	2.10

<b>Rough Oak Bolsters—</b>	
3 x 4	\$.36
4 x 4	.40
4 x 4	.70
5 x 6	1.00

<b>Finished Bolsters—</b>	
2 1/2 and 3 1/2	56c
3 1/2	65c
3 3/4	92c

<b>Rough Oak Wagon Tongues—</b>	
4 x 4, 2 x 4 12 and smaller	\$1.15

<b>Finished Oak Wagon Tongues—</b>	
3 1/2 and smaller	\$1.85
3 3/4	1.45
4	1.55

<b>Two-Inch Sawed Hounds—</b>	
Tongues	Per Pair
Front	38c
Hind	44c
	55c

<b>Wheels—</b>	
0 to 71-inch. A. & B. Grades	50-5%
C. Grades	45-5%
D. Grades	45

<b>Tiring—1 1/2 x 3/4" stocks</b>	
factory	20%
factory	25%

<b>Screws—1 1/2" Thread and less</b>	
	37 1/2%
<b>Rivets—1 1/2" Thread and less</b>	
	37 1/2%

<b>Boring or Boxing less than 10c lots</b>	
	40%
<b>Boring or Boxing 10 sets or more of one size</b>	
	60%
<b>Priming Wheels, net</b>	
	25c
<b>Oiling, not tired, set</b>	
	20c

Allowance of 25 cents per set on all special tired wheels with three or four piece rims.

<b>Oiling, not tired, No. 17 to No. 39</b>	
	25c
<b>Oiling, No. 45 and larger</b>	
	40c

<b>Special Tired Wheels—"F" Grade—3 or 4 piece Rim—</b>	
0 1/2 x 1/4"	8.60
1 1/2 x 1/4"	8.99
8 1 x 1/4"	9.55
8 1 x 5-16"	10.40
9 1 1/2 x 1/4"	\$11.57
9 1 1/2 x 5-16"	12.48
13 1 1/2 x 5-16"	14.78
13 1 1/2 x 3/4"	15.75

<b>Cupped Oak Hubs—</b>	
10 x 14	\$8.80
11 x 14	4.20
11 x 15	4.50
11 x 16	5.10
12 x 16	5.75
12 x 17	6.80
13 x 18	7.00
<b>Plain End Oak Hubs—</b>	
7 x 8 x 9	\$1.80
7 x 9 x 10	1.50
8 x 9 x 10	1.55
8 x 10 x 11	1.80
9 x 10 x 11	1.95
10 x 11 x 12	2.00
10 x 12 x 13	3.00
11 x 13 x 14	4.20
12 x 14 x 15	5.10

<b>Rough Sawed Fellos—</b>	
1 1/2 x 2"	\$1.65
1 1/2 x 2 1/2"	1.75
1 1/2 x 2 1/2"	1.85
8 x 3 1/2"	\$5.75
2 x 2 1/2"	\$1.85
2 1/2 x 2"	3.50
3 x 3"	5.25

<b>Ironed Poles, White, XXX</b>	
1 1/2 x 2 1/2" No. 2	\$5.50
2 x 2 1/2" No. 3	5.50

<b>Ironed Shaft, White, XXX—</b>	
1 1/2 x 2" and smaller	\$2.50
1 1/2 x 2"	1.75
1 1/2 x 2 1/4"	3.55

<b>Farm Wagon Bows—</b>	
Round Top, 1/2 x 2"	\$.60
Flat Top, 1/2 x 2"	.75
Round Top, 3/4 x 2 1/2"	1.85

<b>Standard Size Piano Bodies with Seats—</b>	
Each	\$5.00

<b>Plow Beams</b>	
1 Horse	\$.60
2 Horse	.85
3 Horse	1.30

<b>Spokes and Rims—</b>	
Oak and Hickory Spokes, 50% on Weiss & Lesh List No. 8.	
Finished Rims—XX—1/2"	\$1.75
Finished Rims—XX—1"	1.65
Oak Rims—Discounts	40-10%
Hickory Rims	40%

<b>Wagon Neckyoke Woods—</b>	
Keller & Tamm's List—Discount	25%

<b>Wagon Whiffetree Woods—All grades—</b>	
Keller & Tamm's List Discount	25%

<b>Oval Plow Dbl'trees—Flat Plow Dbl'trees—</b>	
2 1/2 x 36"	\$1.60
1 1/2 x 3 1/2 x 42"	\$2.75
2 x 40"	2.40

<b>Wagon Evener Woods—</b>	
2 x 4 and 2 x 4 1/2—Keller & Tamm's List—Discount	30%
Larger	25%

<b>Buggy Evener Woods—All Grades—</b>	
Keller & Tamm's List—Discount	25%

<b>Buggy Whiffetree Woods—</b>	
Mixed Second Growth and Second Growth—Keller & Tamm's List—Discount	25%

<b>Buggy Neckyoke Woods—All Grades</b>	
Keller & Tamm's List—Discount	25%

**"DUPLEX" BOLT DIE STOCK SETS**

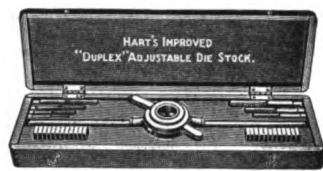

They contain dies that adjust without a wrench and require no reversing after cutting.

**THE HART MFG. CO.**  
2325 E. 20th St. Cleveland, Ohio

**Horse Shoe Bar Iron**

MADE BY

**The Milton Mfg. Company**

**MILTON, PENNA**

Is of Superior Strength and Quality. We can prove it. Write us.



**Best Gasoline Brazing Forge**

IN THE WORLD  
Thousands sold in last ten years. Four sizes. Send for catalog.

The National Rubber & Specialties Co.  
4433-39 Chickering Ave., Winton Place, Cincinnati, Ohio.

**Simonsen Kold Kutter No. 1**  
is the handiest tool you could place on your bench. Made entirely of steel yet low in price. Will cut cold 1/2 x 2 or 1/4 x 6 in. mild steel. Write for our circular K and learn all about this bench shear.

**SIMONSEN IRON WORKS.**  
Sioux Rapids, Iowa, U. S. A.

**"GEARS AND WAGONS"**  
**Selle Gears**  
A quarter of a century of success has placed "Selle Gears" and Wagons in the hands of the largest wagon users in the world. Express and Transfer Companies, Department Stores, Fire Departments, etc.; specify "Selle Gears" and will take no other after once tried.

230 page catalog free  
**THE AKRON-SELLE CO.** Akron, Ohio



SEND US YOUR ORDERS

We Always Have The Stock

# BEALS & COMPANY

Iron, Steel, Hardware  
Blacksmiths' and Wagon Makers'  
Supplies

BUFFALO, N. Y.

Largest stock of iron and steel in New York State



Bench Jointers 5 and 7 in.  
Complete Hand Planers or Jointers 5 in. to 13 in.  
Complete Combined machine Jointers and Saw  
arbor or pole rounding heads with numerous  
other attachments for wood frame tables 5 to 13  
in.  
Circular and square style cutter heads for wood  
frame tables 5 to 17 in.  
Special cutter heads and knives any style or  
length. Write at once for catalogue No. 12 illus-  
trating the full line of machines we make for the  
wood shop.

W. L. Sherwood, Kirksville, Mo.

## EMPIRE STEEL WHEELS



Plain or Grooved  
Tire  
To Fit Any Wagon

Farm Trucks  
All Standard Types

Write today for  
Proposition to Black-  
smiths.

Empire Mfg. Co.  
P. O. Box 307  
QUINCY, ILLINOIS

Reserve  
Your  
Copy  
Now

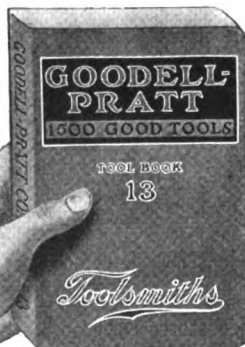

This Book  
shows over 1500 Good  
Tools for all trades.  
Every Blacksmith and  
every repair shop should  
have a copy.

It will be issued late in  
March. Write for your copy  
now.

GOODELL-PRATT COMPANY  
*Toolsmiths*  
GREENFIELD  
MASS., U.S.A.



# Why Pay Double My Price for any Engine?

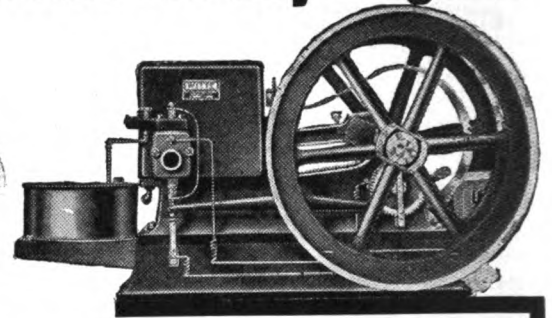

ED. H. WITTE  
Says:

Put a WITTE Engine on your floor. It will do your work and do it well—I guarantee it. You can have a WITTE, Easy-to-Start Gasoline or Kerosene Engine—plenty of power, low operating expense and a big saving in first cost by ordering from Witte—who operates the largest exclusive engine factory in the world selling direct to the user. Capacity 12,000 perfect engines yearly, or at the rate of 1,000 a month—about 40 a day. WITTE Engines are built by experts, using the latest improved engine machinery. My prices are based on low cost of manufacture, using high grade materials.

## WITTE ENGINES

are built in sizes 2, 3, 4, 6, 8, 12, 16 and 22 H-P.—all sold direct to the user at a big saving—no middlemen or jobbers' profits. I have four definite and easy plans of payment:

- 1st. ALL CASH
- 2nd. PART CASH
- 3rd. BANK DEPOSIT
- 4th. NO MONEY DOWN

I can accommodate any worthy, creditable man as to terms. I allow 90 days trial, and guarantee 5 years. I ship brand new engines, shop tested for power, and crate tested before shipping.

MY FREE BOOK tells all about how WITTE Engines are made, why I sell direct, and why you should own a Witte Engine. Write for Free Book, telling me what size engine you will likely use, or need, if interested in better shop power.—ED. H. WITTE, Pres.

**WITTE ENGINE WORKS** 1768 Oakland Avenue  
Kansas City, Mo.  
1768 Empire Building, Pittsburgh, Pa.

## "NEW EASY" 4 Sizes BOLT CLIPPERS "EASY" 2 Sizes

THE  
GENUINE  
TOOL



KNOWN AND  
PREFERRED  
EVERYWHERE

H. K. PORTER

EVERETT, MASS.

U. S. A.

## THE HORSE RASP OF QUALITY



Ask your dealer for the IMPROVED HELLER RASP with keen cutting hard teeth. Made in all patterns and cuts, "Slim," "Light," "Slim Light," and "Fine Cut." Insist on getting the size, kind and cut best suited for your work. It will pay you to give them a trial. New catalogue mailed free on application.

ESTABLISHED IN 1836

HELLER BROTHERS COMPANY

NEWARK, N. J.

## Butterfield's Screw Plates

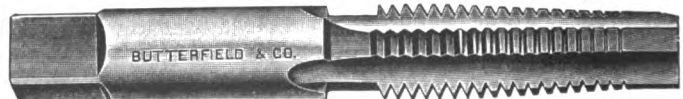

We do not claim to be the oldest manufacturers of Screw Plates. We are not sure that this is any distinction.

Our claims for the superiority of our TAPS and SCREW PLATES are based on actual performance. The rapid growth of our business, is proof positive of the excellence of our product. Be sure you ask for BUTTERFIELDS, and take no substitute.

NEW YORK STORE  
126 Chambers Street

BUTTERFIELD & CO.

DERBY LINE, VT., U.S.A.

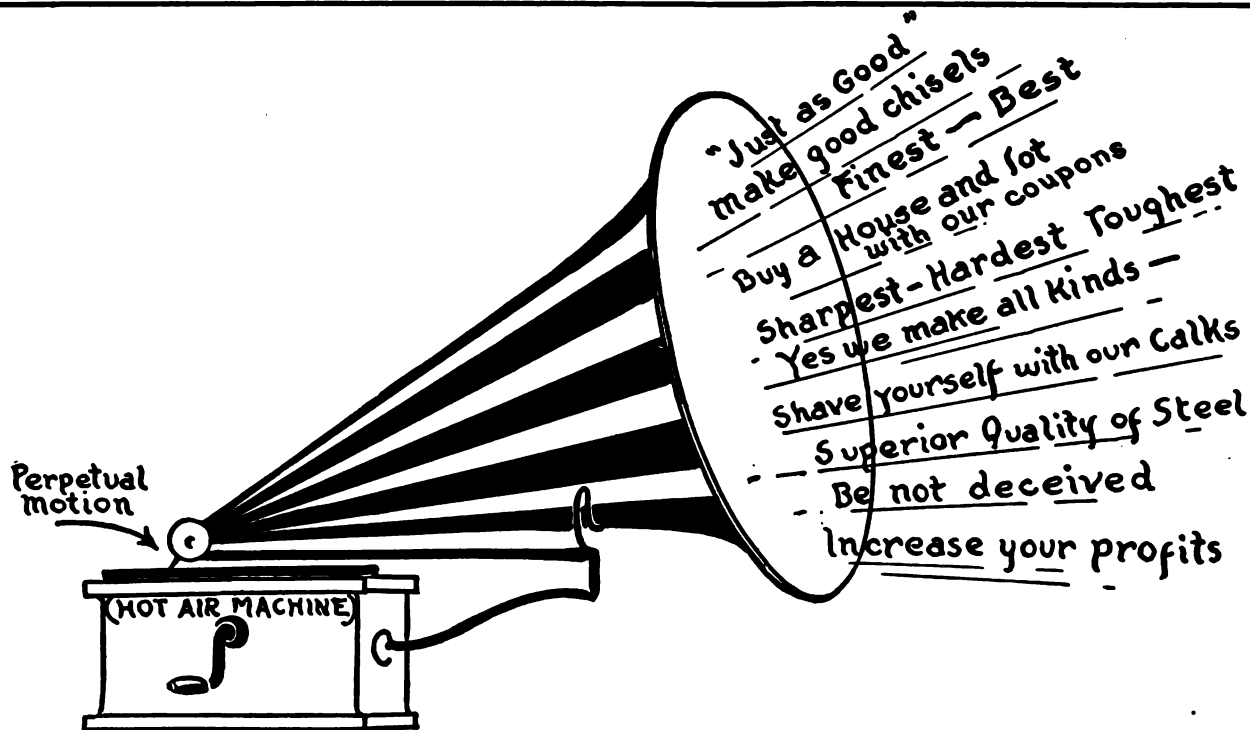

# Mr. Horseshoer



Aren't you tired of listening to these outbursts of hot-air? Be your own judge, that is, be like the man from Missouri, the "Show Me" type.

One test is worth a million claims. We simply say try **Genuine GIANT GRIPS.**

**GIANT GRIP HORSE SHOE CO.,  
OSHKOSH, WISCONSIN.**



## WHY TRY TO GET ALONG WITHOUT THE FAMOUS ?

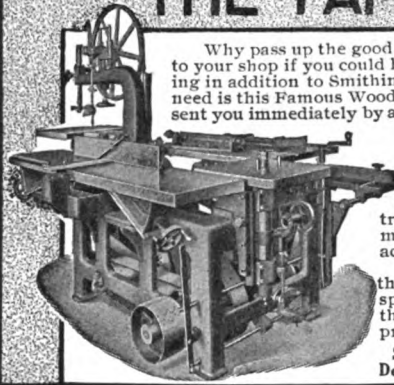

Why pass up the good extra dollars that would come to your shop if you could handle all kinds of woodwork in addition to Smithing and Horseshoeing? All you need is this Famous Woodworker and you can have one sent you immediately by accepting our

### Special Easy Payment Plan

While it is earning its low purchase price—you can get a Famous for only \$125—it will be developing a nice extra trade for you that will put a good many extra profit dollars to your account each week.

Write for circular describing the Famous models and the special attachments which make them doubly useful and doubly profitable. Do it NOW.

SIDNEY TOOL COMPANY  
Dept. 14, Sidney, Ohio, U. S. A.

## NEED HELP?

Our Subscriber's Service Department is ready to help you with the jobs that puzzle—buying of supplies—with your printing, shop plans and bookkeeping—with the thousand and one other things that are always coming up to bother you. When in doubt ask the Service Dept. It's their business to help you.

**THE AMERICAN BLACKSMITH,**

Box 974, :: BUFFALO, N. Y., U. S. A.

## What Would You Think of a Manufacturer—

—who wrote to you with a stub pencil—"We are saving much money because we do not use typewriters and telephones."? You might well wonder whether his merchandise was as much out of date as his business methods.

You know that modern time and labor saving appliances are not added expenses, but that they have superseded slower and more costly processes.

The concern that uses your business paper to tell you its business story is simply making it easier for you to buy intelligently with the least waste of time on your part and theirs.

For the right kind of advertising shortens the distance between human minds just as certainly as the railroad has shortened the distance between places. It is still possible to walk from New York to Chicago, and it is still possible for a business to get along without advertising, BUT—

—don't forget that the seller who does not advertise, is not only paying for the results that such advertising would get him, but he is also *paying more than necessary.*

Progressive advertisers are progressive merchandisers and it pays to do business with them.

## THE ASSOCIATED BUSINESS PAPERS, INC.

*The International Association of Trade, Technical and Class Publications*

ALL OF WHICH HAVE SUBSCRIBED TO THE "STANDARD OF PRACTICE"

Advertising & Selling  
American Architect  
American Blacksmith  
American Exporter  
American Hatter  
American Machinist  
American Paint & Oil Dealer  
American Printer  
American School Board Journal  
Architectural Record  
Automobile, The  
Automobile Dealer and Repairer  
Boot and Shoe Recorder  
Brick and Clay Record  
Buildings & Building Management  
Bulletin of Pharmacy  
Canadian Grocer  
Canadian Railway & Marine World  
Cement World

Clothier & Furnisher  
Coal Age  
Concrete  
Domestic Engineering  
Drygoodsman, The  
Dry Goods Economist  
Dry Goods Reporter  
Editor & Publisher  
Electrical Railway Journal  
Electrical Review & Western Electrician  
Electric World  
Electric Traction  
Engineering & Mining Journal  
Engineering News-Record  
Farm Machinery—Farm Power  
Furniture Manufacturer & Artisan  
Grand Rapids Furniture Record  
Haderdasher, The

Hardware Age  
Hide & Leather  
Hotel Monthly  
Illustrated Milliner  
Implement Age  
Industrial Arts Magazine  
Inland Printer  
Iron Age  
International Trade  
Lumber Trade Journal  
Lumber World Review  
Manufacturing Jeweler  
Marine Engineering  
Merchants Trade Journal  
Metal Worker, Plumber & Steam Fitter  
Metallurgical & Chemical Engineering  
Modern Hospital

Motor Age  
Motor World  
National Builder  
National Druggist  
National Petroleum News  
Power  
Practical Engineer  
Railway Age Gazette  
Railway Electrical Engineer  
Railway Maintenance Engineer  
Railway Mechanical Engineer  
Railway Signal Engineer  
Shoe & Leather Reporter  
Shoe Findings  
Shoe Retailer  
Tea & Coffee Trade Journal  
Textile World Journal  
Transfer & Storage  
Woodworker

**HEADQUARTERS: 220 West 42nd Street, NEW YORK CITY**

*Information concerning Business Papers cheerfully supplied.*

### TRADE LITERATURE AND NOTES.

Gasolene torches for welding and brazing are highly dangerous and have been the cause of many serious accidents.

It was with the purpose of eliminating this danger that the Hauck Manufacturing Company, 140 Cedar street, New York city, designed and manufactured the Hauck Patent Kerosene Torch, used everywhere and acknowledged to be the perfection of blowtorches. It does not smoke or soot. The temperature of the flame is 3,000 degrees Fahrenheit.

For brazing, annealing, straightening shafts, axles, wires, pre-heating and similar heating operations, this blowtorch is very efficient, producing an intense, clear flame. The burner, mounted directly on top of the tank, is designed for kerosene oil. The pump is built inside the tank, and the entire apparatus is complete. The

flame is easily regulated. This torch is more suitable for general shop work than the dangerous gasolene torch.

Full particulars about any of the various types of blowtorches, pre-heaters, portable oil burners, tire heaters, oil forges, etc. made by the Hauck Manufacturing Company (address above) will be cheerfully sent on request.

The Prentiss Vise Company, of 106-110 Lafayette St., New York City announce the publication of their new catalog. This will be valued by every smith who anticipates purchasing a vise, and may be had by sending your name and address on a postal to the above address.

We believe our readers will find of interest the advertising in this issue of the Groetkin Pump Co., Aurora, Ill., who will be glad to send their catalog to anyone on request.

The Groetkin Portable Automatic Measuring Barrel Pump would be of great use and economy in any shop handling automobile work. This pump pumps and automatically measures gasoline, kerosene, oil and other liquids direct from the shipping barrels eliminating the necessity of storage tanks, in order to use a self-measuring pump.

The Groetkin Curb Pump is an excellent outfit attracting attention to the shop or garage, and gives rapid service to customers.

This firm also makes other styles of pumps, exactly to suit your conditions. They will be glad to have you write them and will furnish full information on their complete line of gasolene pumps and accessories.

Continued on Page 44



## Little Giant Power Hammer

With or Without Individual Motor Drive.

400 R. P. M.  
Machine Gun Rapidity and Precision

A Decidedly Dependable Drudgery Destroying Device

Every LITTLE GIANT POWER HAMMER made is still in use, including the first one manufactured more than twenty-five years ago.

Their 1915 upkeep expense, all sizes and ages, averaged 48 cents each, or less than 2/5 of 1% of original cost to user. There is no wear-out to them. More sold than all others combined.

They save elbow grease and do better work than is possible by hand, paying for themselves every few months. Sold on 30 days' trial. Easy terms, if desired. Write your jobber, or direct to us.

**MAYER BROTHERS COMPANY**  
101 Rock Street, MANKATO, MINN., U. S. A.

## No. 6471

This O. K. Screw Plate put up in a Leather Roll is just what you need for emergency work and will be found just as practical as Screw Plates in Wooden Boxes.

Your *emergency car* needs one to be complete.

**F. E. WELLS & SON COMPANY,**  
*Greenfield, Mass., U. S. A.*

You should have our 7-A CATALOG on Thread Cutting Tools

## RAYMOND POLE SPRINGS

Save Your Horse's Neck

### Keystone Trace Spring

### Keystone Brake Springs

Why not befriend your horse and prolong his life by using this Trace Spring.

Write your Jobber for Circular and Prices

**RAYMOND MANUFACTURING CO.**  
CORRY - LIMITED - PA.

## ONE KICK MIGHT COST

a hundred dollar doctor bill and keep you out of the shop for months—in fact nearly ruin your business. Why take the chance? Make sure such a disaster can't happen to you by simply using

### Barcus Safety Horse Stocks

Entirely different from the old style horse stocks with their bothersome ropes, straps and buckles. All chances for injury are removed by the Safety Foot Clamp—a fortunately discovered automatic device that holds the foot like a vise. Its action is positive, quick and safe—you do not even have to touch the foot or limb of the horse.

The Barcus sells at a price so reasonable no smith can afford to be without the protection of these stocks. As you value your life and health, as you seek to protect and support your family, do them and yourself the justice of writing for complete information without delay.

**The Barcus Mfg. Co.,**  
Wabash, Indiana.

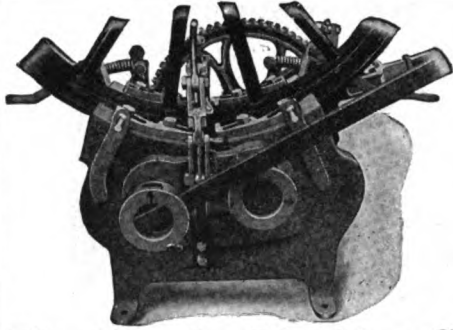

## The Brooks Cold Tire Setter

Sets tires cold on the wheel and is the pioneer edge-grip hand-power cold tire setter. Used and officially endorsed by the United States Government in the Department of War and Interior. Thousands of blacksmiths in the U. S. consider it the most profitable machine in their shop. We build both hydraulic and lever cold tire setters. The Brooks does the work quicker and better than any other cold tire setter on the market and should be in every blacksmith and carriage repairer's shop. Write for catalog and prices.

We are also manufacturers of the latest improved Oxy-Acetylene Welding machines and generators, equipped with our famous Safety Flash Back Valve. It prevents explosions.

We also build Welding Outfits to be used with cylinder gases.

Our catalog will interest you and is free for the asking.

The Brooks Machine Company, Wichita, Kansas



Bench Jointers 5 and 7 in.  
Complete Hand Planers or Jointers 5 in. to 13 in.  
Complete Combined machine Jointers and Saw arborers or pole rounding heads with numerous other attachments for wood frame tables 5 to 13 in.

Circular and square style cutter heads for wood frame tables 5 to 17 in.

Special cutter heads and knives any style or length. Write at once for catalogue No. 12 illustrating the full line of machines we make for the wood shop.

W. L. Sherwood, Kirksville, Mo.

"NEW EASY" 4 Sizes **BOLT CLIPPERS** "EASY" 2 Sizes

THE GENUINE TOOL



KNOWN AND PREFERRED EVERYWHERE

H. K. PORTER EVERETT, MASS. U. S. A.

### THE HORSE RASP OF QUALITY



Ask your dealer for the IMPROVED HELLER RASP with keen cutting hard teeth. Made in all patterns and cuts, "Slim," "Light," "Slim Light," and "Fine Cut." Insist on getting the size, kind and cut best suited for your work. It will pay you to give them a trial. New catalogue mailed free on application.

ESTABLISHED IN 1836

HELLER BROTHERS COMPANY NEWARK, N. J.

### EMPIRE STEEL WHEELS



Plain or Grooved Tire  
To Fit Any Wagon  
Farm Trucks  
All Standard Types

Write today for Proposition to Blacksmiths.

Empire Mfg. Co.  
P. O. Box 307  
QUINCY, ILLINOIS

### Butterfield's Screw Plates



We do not claim to be the oldest manufacturers of Screw Plates. We are not sure that this is any distinction.

Our claims for the superiority of our TAPS and SCREW PLATES are based on actual performance. The rapid growth of our business, is proof positive of the excellence of our product. Be sure you ask for BUTTERFIELD'S, and take no substitute.

NEW YORK STORE 126 Chambers Street BUTTERFIELD & CO. DERBY LINE, VT., U.S.A.

### Tools for Blacksmiths



**GOODSELL PRATT**  
1500 GOOD TOOLS

TOOL BOOK 13

*Toolsmiths*

BENCH DRILLS  
BENCH HACK SAWS  
BREAM DRILLS  
BUTTERISES  
CHAIN DRILLS  
DRILL CHUCKS  
GIMLET BITS  
HACK SAWS  
HOLLOW AUGERS  
SADDLER'S PUNCHES  
WALL DRILLS  
WASHER CUTTERS

All shown in this free book

GOODSELL-PRATT COMPANY  
*Toolsmiths*  
GREENFIELD MASS., U.S.A.

### KEROSENE ENGINES

OTTAWA LATEST DESIGN



Durable, Powerful, Reliable, Magsive. Built to last; to do hard, heavy work. Uses Cheapest Fuel. Pull 1/4 to 1/2 horse-power more than rated. 3 Months Trial. Easy Terms. Sizes 1 1/2 to 22 H-P. Easy to start. No Cranking. No batteries. 10 Year Guarantee. Most practical engine ever built. Engine book free. A Postal brings it.

THE OTTAWA MANUFACTURING CO.,  
1791 King Street, OTTAWA, KANSAS.

#### TRADE LITERATURE AND NOTES.

Continued from Page 42

In this day of automobile repair work, of supplying new parts and accessories for automobiles, it is indeed a pleasure to know that Buob & Scheu, of Cincinnati, Ohio, can furnish a wide variety of covers, automobile tops and seats. They want to encourage the blacksmith to sell these to automobilists.

There are very interesting novelties including closed tops for Ford Cars and they also make a trailer for camping out.

The Buob & Scheu catalog, featuring as it does so many necessary automobile accessories, should be in the hands of every reader of The American Blacksmith. Send



New Building where Buob & Scheu are now located in Cincinnati, O.

for your copy today to Buob & Scheu, Court St. & Broadway, Cincinnati, O.



**CURRENT HEAVY HARDWARE PRICES.**

The following quotations are the lowest prices generally prevailing throughout March, 1917. They are subject to change without notice, and higher prices are charged according to quality, specification and other conditions.

Anvils have advanced another notch. Last month's reports show an advance to \$.15 and \$.16; March shows a climb to \$.17½ and \$.18½.

Plow goods have climbed a half-cent in almost every item.

Shoes and Calks seem steady, but manufacturers report a continually advancing market on raw material and expect to boost their own prices shortly.

Business is booming and the demand for goods of all kinds during the month of March was very good.

**Horse Shoes—**

All Iron Shoes	.....	\$5.75
Steel Shoes	.....	5.75
No. 0 and No. 1, 25 cents extra.	15 cents per keg additional charged for packing more than one size in a keg.	
Mule Shoes	.....	
X. L. Steel Shoes	.....	
Countersunk Steel Shoes	.....	\$6.55
Tip Shoes	.....	
Goodenough, heavy	.....	
Goodenough, sharp	.....	
Toe Weight, pr.	.....	.25
Side Weight, pr.	.....	.25
E. E. Light Steel	.....	6.30
Steel Driving	.....	
O. O. Mule Shoes, extra	.....	

Anvils ..... \$.17½ & \$.18½

**Merchant Bar Iron—**

\$4.00 rates, full extras, and 20 cents per 100 pounds extra for broken bundles.

**Steel Bars—**

\$4.00 rates, full extras.

**Toe Calks—**

Blunt	.....	Per Box
Sharp	.....	\$1.90

**Screw Calks—**

Blizzard M	\$20.00	\$20.00	\$22.00	\$22.00	\$24.00
Sure Grip M	20.00	20.00	22.00	22.00	24.00
Bl. Diam. M	20.00	20.00	22.00	24.00	24.00
Red Tip M.	22.00	22.00	24.00	24.00	26.00
Rowe, Jr. M	20.00	20.00	22.00	22.00	24.00
Ring Pt. M.	22.00	22.00	24.00	24.00	26.00

**Plow Goods—**

Blank Shares	.....	Soft	Solid	
Center	.....	Cast	Crucible	
Landside Plates	.....	\$.18½	\$.13	\$.14
Lister Lays—Triangle	.....	.28	.15	.17
Lister Lays—V-Pattern	.....	.26	.15½	.17½
Lister	.....		.17½	
Mould Boards	.....	.21	.13	.15
Cult. Shov. Blanks	.....	.20	.18	.15

**Hickory Lumber—Per Foot—**

1 to 2½	.....	\$.10
1½ to 4¼	.....	.12

**Ash and Oak Lumber—Per Foot—**

1 —1¼	.....	\$.08	2½—3	.....	\$.09
1½—2	.....	.08½	3½—4	.....	.10

**Yellow Poplar Lumber, Per M. Feet—**

6 to 12	18 to 17	18 to 24	
¾"	.....	\$75.00	\$ 85.00
1"	.....	75.00	85.00
1½"	.....	78.00	85.00
2"	.....	85.00	90.00
2½"	.....	85.00	90.00

**Rough Hickory Axles—**

3 x 4	x 6	ft.	.....	\$.70
3½ x 4½	x 6	ft.	.....	.95
4 x 5	x 6	ft.	.....	1.20
5 x 6	x 6	ft.	.....	2.25
4 x 5	x 6½	ft.	.....	1.75
4½ x 5½	x 7	ft.	.....	2.80
5 x 6	x 7	ft.	.....	2.80
5 x 7	x 7	ft.	.....	3.40

**Finished Hickory Axles—**

For 2½ and 2¾ Skeins	.....	\$.95
For 3 Skeins	.....	1.38
For 3½ Skeins	.....	1.48
For 3¾ Skeins	.....	1.68
For 4½ Skeins	.....	1.90
For 4 Skeins	.....	2.10

**Rough Oak Bolsters—**

3 x 4	.....	\$.86	4 x 4½	.....	\$.40	12 x 14	.....	\$1.55	16 x 16	.....	\$1.75
4 x 4	.....	.60	4 x 4	.....	.70	2.20	2.55	3.00			
5 x 6	.....	1.00	1.20								

**Finished Bolsters—**

2½ and 3¾	.....	56c
3¾	.....	65c
3¾	.....	92c

**Rough Oak Wagon Tongues—**

4 x 4, 2 x 4 12 and smaller	.....	\$1.15
-----------------------------	-------	--------

**Finished Oak Wagon Tongues—**

3½ and smaller	.....	\$1.35
3¾	.....	1.45
4	.....	1.55

**Two-Inch Sawed Hounds—**

Tongues	.....	Per Pair	38c
Front	.....	44c	
Hind	.....	55c	

**Wheels—**

0 to 71-inch, A. & B. Grades	.....	50-5%
C. Grades	.....	45-5%
D. Grades	.....	45 %
Tiring—1¾ x ¾" stocks	.....	20%
factory	.....	25%
Screws—1¼" Thread and less	.....	37½%
Rivets—1¼" Thread and less	.....	37½%
Boring or Boxing less than 10c lots	.....	40%
Boring or Boxing 10 sets or more of one size	.....	60%
Priming Wheels, net	.....	25c
Oiling, not tired, set	.....	20c
Allowance of 25 cents per set on all special tired wheels with three or four piece rims.	.....	
Oiling, not tired, No. 17 to No. 39	.....	25c
Oiling, No. 45 and larger	.....	40c

**Special Tired Wheels—"F" Grade—3 or 4 piece Rim—**

0 ¾ x ¼"	.....	\$ 8.60	9 1¼ x ¼"	.....	\$11.57
1 ¾ x ¼"	.....	8.99	9 1¼ x 5-16	.....	12.48
3 1 x ¼"	.....	9.55	18 1¼ x 5-16	.....	14.78
3 1 x 5-16"	.....	10.40	18 1¼ x ¾"	.....	16.75

**Cupped Oak Hubs—**

10 x 14	.....	\$8.30	7 x 8 x 9	.....	\$1.30
11 x 14	.....	4.20	7 x 9 x 10	.....	1.50
11 x 15	.....	4.50	8 x 9 x 10	.....	1.55
11 x 16	.....	5.10	8 x 10 x 11	.....	1.80
12 x 16	.....	5.75	9 x 10 x 11	.....	1.95
12 x 17	.....	6.30	9 x 11 x 12	.....	2.00
13 x 18	.....	7.00	10 x 12 x 13	.....	3.00
			11 x 13 x 14	.....	4.20
			12 x 14 x 15	.....	5.10

**Rough Sawed Fellos—**

1½ x 2"	.....	\$1.85	2x2½"	.....	\$1.85
1½ x 2¼"	.....	1.75	2½ x 2"	.....	3.50
1½ x 2½"	.....	1.85	3 x 3"	.....	5.25
3 x 3½"	.....	\$5.75			

**Ironed Poles, White, XXX**

1½ x 2¼" No. 2	.....	\$5.50
2 x 2½" No. 3	.....	5.50

**Ironed Shaft, White, XXX—**

1½ x 2" and smaller	.....	\$2.50
1½ x 2"	.....	1.75
1½ x 2¼"	.....	3.55

**Farm Wagon Bows—**

Round Top, ½ x 2"	.....	\$.60
Flat Top, ½ x 2"	.....	.75
Round Top, ¾ x 2½"	.....	1.35

**Standard Size Piano Bodies with Seats—**

Each	.....	\$5.00
------	-------	--------

**Plow Beams**

1 Horse	.....	\$.60
2 Horse	.....	.85
3 Horse	.....	1.30

**Spokes and Rims—**

Oak and Hickory Spokes, 50% on Weiss & Lesh List No. 8.	.....	
Finished Rims—XX—¾"	.....	\$1.75
Finished Rims—XX—1"	.....	1.67
Oak Rims—Discounts	.....	40-10%
Hickory Rims	.....	40%

**Wagon Neckyoke Woods—**

Keller & Tamm's List—Discount	.....	25%
-------------------------------	-------	-----

**Wagon Whiffletree Woods—All grades—**

Keller & Tamm's List Discount	.....	25%
-------------------------------	-------	-----

**Oval Flow Dbl'trees—Flat Flow Dbl'trees—**

2 x 36"	.....	\$1.60	1 x 3½ x 42"	.....	\$2.75
2 x 40"	.....	2.40			

**Wagon Evener Woods—**

2 x 4 and 2 x 4½—Keller & Tamm's List—Discount	.....	30%
Larger	.....	25%

**Buggy Evener Woods—All Grades—**

Keller & Tamm's List—Discount	.....	25%
-------------------------------	-------	-----

**Buggy Whiffletree Woods—**

Mixed Second Growth and Second Growth—Keller & Tamm's List—Discount	.....	25%
---	-------	-----

**Buggy Neckyoke Woods—All Grades**

Keller & Tamm's List—Discount	.....	25%
-------------------------------	-------	-----

**"GEARS AND WAGONS"**

**Selle Gears**

A quarter of a century of success has placed "Selle Gears" and Wagons in the hands of the largest wagon users in the world. Express and Transfer Companies, Department Stores, Fire Departments, etc.; specify "Selle Gears" and will take no other after once tried.

230 page catalog free  
THE AKRONSELLE CO. Akron, Ohio

**"DUPLEX" BOLT DIE STOCK SETS**

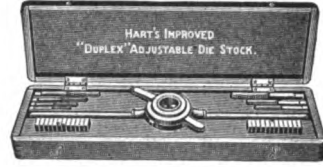

They contain dies that adjust without a wrench and require no reversing after cutting.

THE HART MFG. CO.  
2325 E. 20th St. Cleveland, Ohio

**Horse Shoe Bar Iron**

MADE BY

**The Milton Mfg. Company**

**MILTON, PENNA**

Is of Superior Strength and Quality. We can prove it. Write us.



**Best Gasoline Brazing Forge IN THE WORLD**

Thousands sold in last ten years. Four sizes. Send for catalog.

The National Rubber & Specialties Co.  
4433-39 Chickering Ave., Winton Place, Cincinnati, Ohio.



**Simonsen Kold Cutter No. 1** is the handiest tool you could place on your bench. Made entirely of steel yet low in price. Will cut cold ½ x 2 or ¼ x 6 in. mild steel. Write for our circular K and learn all about this bench shear.

SIMONSEN IRON WORKS.  
Sioux Rapids, Iowa, U. S. A.





# I CAN Make You The Best PRICE

## On a Kerosene Engine Save You \$25 to \$100

I have been making and selling good Engines for over 30 years. I make nothing but Kerosene, Gasoline and Gas Engines. My Kerosene Engine has been on the market longer than some advertisers have been in business, and it will operate successfully on Kerosene, Gasoline, Distillate, Motor Spirits, Solar Oil, or Naptha. WITTE Kerosene Engines are not an experiment. They are a time-tried, time-proven success; hundreds are in use in every state in the U. S.

### WITTE ENGINES

Kerosene or Gasoline, are fuel savers. Steady, Strong, and powerful, easy to operate, long-lived as proven by their records, which goes back further than any other similar manufacturer. My Engines are guaranteed for 5 years; sold on 90 Days Trial, and I can ship at once. Terms Cash, Payments or Deposit.

**FREE** Three-color book, 35 pages, "How to Judge Engines", fully illustrated. Write today, Ed. H. Witte, Pres.

**WITTE ENGINE WORKS**

1765 Oakland Ave., Kansas City, Mo.  
1765 Empire Bldg., Pittsburgh, Pa.

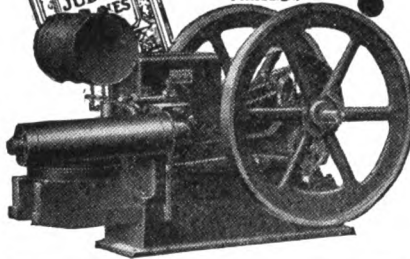

## GIVE YOUR SHOP THE RIGHT PUSH

How can you expect your shop to make more money for you unless it has steady, ample power? you can supply that first essential right away by buying a Galloway Masterpiece Engine on one of the six special plans outlined in my new 250 page catalog.

Aside from the great convenience and economy in buying a Galloway engine you KNOW when you have a Galloway that you have the final accomplishment in modern engine making—a heavy weight, long stroke, large bore engine, guaranteed for five years, that gives your shop the power it must have at a cost so low you never feel it. Write for catalogs and details immediately.

**WM. GALLOWAY, Pres.**

The William Galloway Company  
925 Galloway Station, Waterloo, Iowa.



1 3-4 H. P. \$26.75  
6 H. P. \$98.75

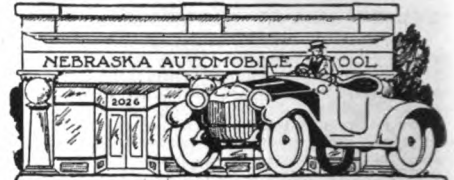

## Can You Repair Gas Engines, Autos and Tractors?

Don't let this profitable business go to the other shop.

Be prepared to handle it in your town.

Take a course of study at the Nebraska Auto School, and you can more than double your shop profits.

The course is simple, easy-to-learn and thoroughly practical.

Write today for our catalog and letters from graduates.

**NEBRASKA AUTOMOBILE SCHOOL,**  
2026 Farnam Street,  
OMAHA, NEBRASKA.

## WONDER DISC SHARPENERS

### SAVE 1/2 THE TIME AND ALL THE LABOR

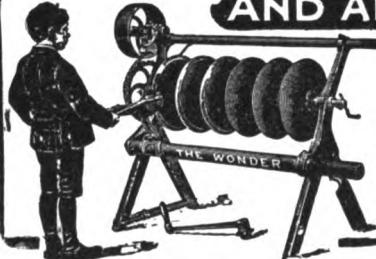

THE WONDER is the only machine adjusted to all conditions.

- Can shear any part of edge to any bevel.
- Can sheak back from edge as far as required.
- Can use tool on either side of disc.
- Can shift from one disc to another.
- Can do all this without the turn of a set screw or nut, is a positive feed, automatically adjusts itself to wobbling or bent discs; knives made of best grade self-tempered steel; will last a lifetime; for hand and power. For prices, write to your jobber or

**A. E. DURNER, Manufacturer**  
Main Office: Evansville, Wisconsin, U. S. A.  
Made in Evansville, Wis., and Brandon, Man., Canada.

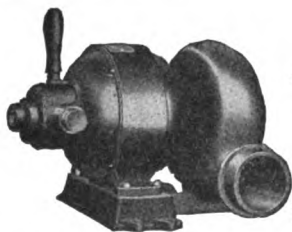

## "KAZOO" Variable Speed BLOWER

We are willing to convince you that this is the best blower on the market.

Write for full information.

**R. P. WARNER ELECTRIC COMPANY**  
KALAMAZOO, MICHIGAN

## A GREAT BARGAIN

Here's a chance to get a genuine American Calking Machine at YOUR OWN PRICE. Guaranteed to be as good as new. Now is the time to buy a calking machine and put it to work making money for you. For further particulars. Address

**A. W. B. A.**

Care of American Blacksmith Co., Buffalo, N. Y.

## Parks' Single and Combination Wood Working Outfits

We were the originators of the Circular Saw, Band Saw, Jointer Combination; our latest improvement is the 6 in. Jointer with undercut attachment for sizing material—joints by passing material over cutter head and sizes it by passing it back under the cutter head. All machines ready for instant use.

Machines are made in large quantities which enable us to sell at lowest prices and make immediate shipment.

Write for Catalog

**Parks Ball Bearing Machine Co.**  
4100 Fergus St., Cincinnati, Ohio

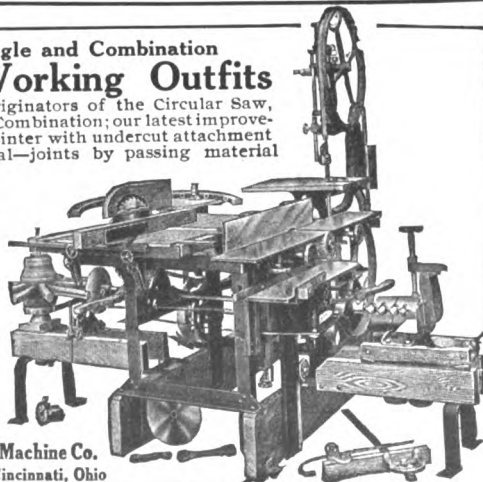

## BETTER THAN THREE SLEDGE HAMMERS

### Little Iowa Power Hammer No. 3

No three men can hammer out as much work as this easily operated, powerful hammer. And it has an even stroke, and accuracy impossible to attain by human efforts.

Powerful 35-pound hammer head with a total weight of 850 pounds and a compact base, 22 inches by 38 inches. Guaranteed to satisfy. If it fails, send it back at our expense. We'll refund your money. Price, \$75.00. Send for descriptive booklet.

Every United States jobber represents us. Canadian Agent: D. Ackland & Son, Ltd., Winnipeg, Can. Agent for Montevideo-Uruguay, Caso en Pando: Ambrosia Bertolotti.

**MODERN SALES CO.**

Hampton, Iowa - - - U. S. A.

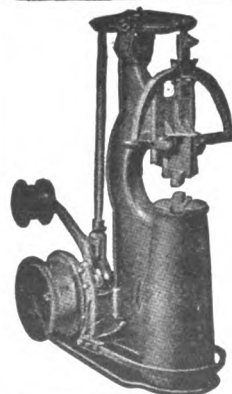



**IMPERIAL WELDING AND CUTTING EQUIPMENT**  
**OXY-ACETYLENE PROCESS**

**QUALITY**

**BIG PROFITS** A relatively small investment in one of our outfits will give you exceedingly large returns and at the same time gives you an equipment that is unequaled in safety, economy and efficiency.

Practical mechanics with a little practice soon become efficient welders. Do not permit the most profitable work to go elsewhere — equip now — you will never regret it — particularly if you select an Imperial Outfit.

**FREE BOOK** — Our new illustrated catalog shows work actually done, gives cost of operation and other valuable data.

**The Imperial Brass Mfg. Co.,**  
 1220 West Harrison Street, :: Chicago

**UNLIMITED OPPORTUNITIES**  
**FOR THE AUTO SMITH**

**WHO HAS THE PROPER TRAINING**

Just because you might know something about heating and pounding metals you wouldn't attempt horseshoeing until you were familiar with the horse.

But it's just as foolish to try motor car repairing until you are familiar with the inner workings and troubles of the automobile.

This expert information can be gained in a few weeks, however, if you come to the Greer School and learn by the wonderful Greer system of first-hand personal instruction. It would be the wisest move of your career — why not write NOW for the details?

**THE GREER COLLEGE OF MOTORING**  
 Greer Bldg.,  
 1519-1521 Wabash Ave.,  
 Chicago, Ill.



**STAR STEEL SHAPES**  
**THE STANDARD**  
**PLOW REPAIRS**  
**FOR 30 YEARS**



**SOFT CENTER**  
**SOLID CAST AND**  
**CRUCIBLE STEELS**



The "STAR" guarantees the Quality

**STAR MANUFACTURING COMPANY**  
 CARPENTERSVILLE, ILL.

**Don't Let This Profit Slip Through Your Fingers**

There is big profit for the man who can repair broken machinery parts quickly and cheaply. Here is a welding and cutting outfit that will repair them so they will be stronger than when new.

**VULCAN**

**Oxy-Acetylene Welding and Cutting Outfits**

The Vulcan will weld any metal that can be welded, quicker and better than it can be welded by any other process. It will cut steel plates and bars quicker than they can be cut by machinery. It will clean carbon out of engine cylinders quicker and more thoroughly than it can be done by any other method. It is the cheapest way to do these things.

Just the thing for machine shops, garages, implement dealers, and large farms and mines. It saves long waiting for parts to replace those that may be broken. It often avoids tearing machinery down to do the work.

It pays to get a Vulcan in preference to any other outfit — because it is most complete, most economical of fuel, and because it will handle any job large or small. Write for full information; ask for Catalog A. 4.

**VULCAN PROCESS CO.,**  
 2427 University Ave., S. E., Minneapolis, Minn.

**Bertschy**  
**KAN-FIX IT**

**What?** — broken castings, cylinders, pistons, connecting rods, crank shafts, crank cases, transmission cases, axles and housings, frames or parts, steering gears, wheels, radiators, ignition apparatus.

We also make drive shafts, axles, transmission parts, motor and ignition parts, pistons and rings, bushings and bearings, models and patterns, welding apparatus.

— and say, you should know about **Bermo Equipment** for welding. With our liberal terms you can buy an outfit and let the outfit pay for itself. **And it Pays Big.**

Write us — no obligation. Just send a postal.

**Bertschy Manufacturing and Engineering Company**  
 OMAHA, NEBRASKA, U. S. A.



**The American Represents the Standard in Oxy-Acetylene Welding and Cutting Apparatus**



Our Model O. W. Outfit is designed for heavy work and will withstand the constant service that the blacksmith and boiler shop demand.

An injector type torch recognized as the most efficient and due to the exactness of construction cannot be made to back-fire. Large welding jobs that are entirely out of range of the ordinary welding outfit are successfully and easily accomplished with the AMERICAN positively non-back-firing torch.

Write for descriptive booklet.

**American Welding Co. INC.**  
 2724 Michigan Ave.,  
 Chicago, Ill.

Model O. W.

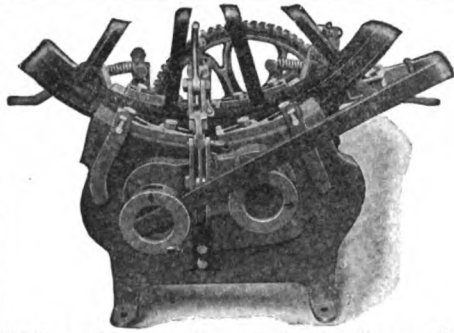

### The Brooks Cold Tire Setter

Sets tires cold on the wheel and is the pioneer edge-grip hand-power cold tire setter. Used and officially endorsed by the United States Government in the Department of War and Interior. Thousands of blacksmiths in the U. S. consider it the most profitable machine in their shop. We build both hydraulic and lever cold tire setters. The Brooks does the work quicker and better than any other cold tire setter on the market and should be in every blacksmith and carriage repairer's shop. Write for catalog and prices.

We are also manufacturers of the latest improved Oxy-Acetylene Welding machines and generators, equipped with our famous Safety Flash Back Valve. It prevents explosions.

We also build Welding Outfits to be used with cylinder gases.

Our catalog will interest you and is free for the asking.

The Brooks Machine Company, Wichita, Kansas

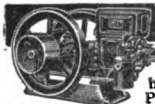

### KEROSENE ENGINES OTTAWA LATEST DESIGN

Durable, Powerful, Reliable, Massive. Built to last; to do hard, heavy work. Uses Cheapest Fuel. Pull  $\frac{1}{4}$  to  $\frac{1}{2}$  horse-power more than rated. **3 Months Trial. Easy Terms.** Sizes 1 $\frac{1}{4}$  to 22 H-P. Easy to start. No Cranking. No batteries. **10 Year Guarantee.** Most practical engine ever built. Engine book free. A Postal brings it. **THE OTTAWA MANUFACTURING CO.,**  
1791 King Street, OTTAWA, KANSAS.

"NEW EASY"

4 Sizes

### BOLT CLIPPERS

"EASY"

2 Sizes

THE GENUINE TOOL



KNOWN AND PREFERRED EVERYWHERE

H. K. PORTER

EVERETT, MASS.

U. S. A.

*Genuine  
giant grip  
Calks*

### TRADE LITERATURE AND NOTES.

In these days, with the warring nations taking such enormous quantities of raw materials, it is a real satisfaction to still find manufacturers able and ready to supply the local demand for their product with any quantity desired.

Mr. J. H. Bush, President of the Bush Motor Company, announces that his concern has recently succeeded in closing contracts for a heavy supply of materials, which will enable them to make prompt deliveries at all times, no matter how large the order.

The unusual demand for their attractive, low-priced light car, has made a larger output necessary and a consequent lower manufacturing cost.

For this reason they have been able to offer a variety of new improvements in the 1917 model—longer wheel base, greater comfort, better control, more power, one-man top, etc., yet with no increase in their old price of \$725.

Complete details for arranging agency connections may be had by addressing Mr. J. H. Bush, Bush Temple, Chicago, Ill.

### Butterfield's Screw Plates

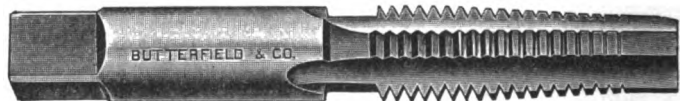

We do not claim to be the oldest manufacturers of Screw Plates. We are not sure that this is any distinction. Our claims for the superiority of our TAPS and SCREW PLATES are based on actual performance. The rapid growth of our business, is proof positive of the excellence of our product. Be sure you ask for BUTTERFIELDS, and take no substitute.

NEW YORK STORE  
126 Chambers Street

BUTTERFIELD & CO. DERBY LINE, VT., U.S.A.

With the establishment of their new plant at East 49th Street and Superior Avenue, Cleveland, Ohio, the Steel Socket Shaft End Company announces a new innovation in manufacturing methods: every finished product undergoes a thorough inspection by one of the heads of the concern, before it is placed in stock.

This plan, together with their new and up-to-date machinery and greatly increased output, promises better service

and greater satisfaction than ever among purchasers of their shaft and pole ends.

Every year sees the development of some new labor-saving device or improvements on the old, designed to lighten the burdens of the hard-working blacksmith.

Perhaps the greatest little labor-saver brought out within recent years is the new 1917 model calking machine, manufactured by the L. S. P. Calking Machine

(Continued on page 40.)



# WILLIS Oxy-Acetylene Apparatus WELDER'S

Write for catalogue

**Henderson-Willis Welding & Cutting Company**

2305-7-9 No. 11th St. St. Louis, Mo.

## TURN THAT STREAM OF PROFITS INTO YOUR SHOP

Why longer let the good money in oxy-acetylene welding pass on to another shop? It is ready to stop at your door if you do the work. And all you need do to capture these good extra profits and make a welding reputation for your shop is to put in this

### IDEAL WELDER

Then you are ready to tackle the largest or smallest welding jobs with complete success. And you do not have to make a large investment—the IDEAL outfit is low priced enough to pay for itself in an unusually short time.

You will be well repaid if you write immediately for complete information regarding the IDEAL outfit.

**GENERAL WELDING CO.**

394 14th Street. Hoboken, N. J.

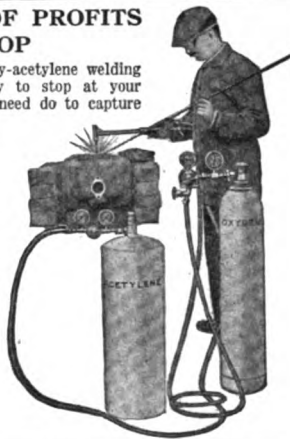

# Safety First For Welders

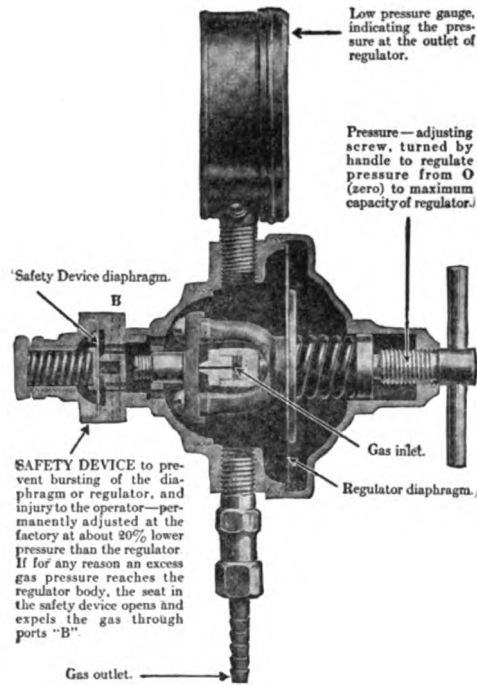

SAFETY DEVICE to prevent bursting of the diaphragm or regulator, and injury to the operator—permanently adjusted at the factory at about 20% lower pressure than the regulator. If for any reason an excess gas pressure reaches the regulator body, the seat in the safety device opens and expels the gas through ports "B".

## B-B-B Diaphragm Safety Device

How often have you heard of a serious accident because of the poor design or weakness of a regulator. Because of the nature of oxy-acetylene welding and cutting, it is of the utmost importance that the apparatus used be properly designed and made to insure the operator.

## Accidents Are Impossible

The B-B-B Diaphragm safety device takes care of any excess gas pressure—the safety device works like the blow-off on a steam boiler. The pressure never reaches the danger point. B-B-B regulators are strong, durable and reliable.

## Welding and Cutting Torches

B-B-B welding and cutting torches are made with the same care and thought as are B-B-B regulators. They are built to give maximum results with perfect safety.

Send for Complete Catalog — It's Free

**The Bishop-Babcock-Becker Co.,**  
General Offices and Factories: Cleveland, Ohio  
Branches in the Larger Cities

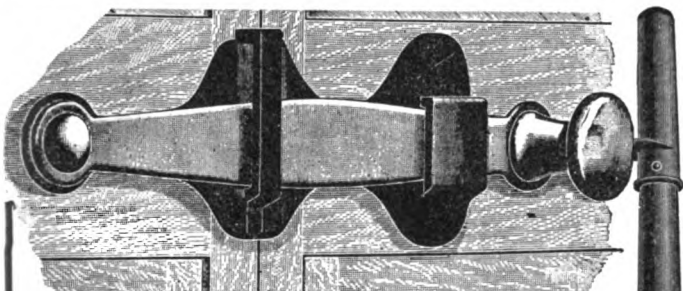

## Specialties for Vehicle Builders and Repairers

The three cuts appearing on this page illustrate our line of specialties of interest to all manufacturers of carriages, buggies and wagons, and to repairers of the same, as well as jobbers and other distributors of vehicle material.

Ours is the original **Double Tube Steel Socket Shaft End**. Why buy imitations when you can get the original? We are making them of double tube steel, the inner tube being pressed and crimped into the outer tube. The filler is inserted after the tube is enameled, thereby retaining the natural life and strength of the wood. Other improvements have also been incorporated. Send for latest circular.

Our **Splice Joint Pole Ends** are easy to put on and make a permanent job. They will not twist or break off where the woods meet. Tube is enameled inside as well as out, preventing rust.

The **Perfection Lock** is the simplest and most reliable fastener for delivery wagon doors that has ever been offered. Made of malleable iron and fitted with steel springs, which will continue to maintain the required pressure in the most severe service. Substantially made to withstand the hardest use.

Your customers will obtain maximum service from their vehicles if you use our pole and shaft ends and locks.

Send for descriptive circulars and prices to the trade. In asking quotations, state quantity you buy.

**STEEL SOCKET SHAFT END CO.**

1432 E. 49th Street  
CLEVELAND - OHIO

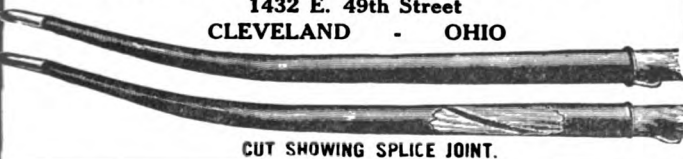

CUT SHOWING SPLICE JOINT.



## ABSORBINE STOPS LAMENESS

from a Bone Spavin, Ring Bone, Splint, Curb, Side Bone, or similar trouble and gets horse going sound. It acts mildly but quickly and good results are lasting. Does not blister or remove the hair and horse can be worked. Page 17 in pamphlet with each bottle tells how. \$2.00 a bottle delivered. Horse Book 9 M free. **ABSORBINE, JR.**, the antiseptic liniment for mankind, reduces Painful Swellings, Enlarged Glands, Wens, Bruises, Varicose Veins; heals Sores. Allays Pain. Will tell you more if you write. \$1 and \$2 a bottle at dealers or delivered. Liberal trial bottle for 10c stamps. W. F. YOUNG, P.D.F., 230 Temple St., Springfield, Mass.



## EMPIRE STEEL WHEELS

Plain or Grooved  
Tire  
To Fit Any Wagon  
Farm Trucks  
All Standard Types

Write today for  
Proposition to Blacksmiths.

Empire Mfg. Co.  
P. O. Box 307  
QUINCY, ILLINOIS

**Free to Blacksmiths**

**GOODELL-PRATT  
1500 GOOD TOOLS**

REAL BOOK  
13

*Toolsmiths*

THIS BOOK will be sent FREE to any Blacksmith who writes, mentioning this magazine. It shows over 1500 Good Tools, many of which are needed in every Blacksmith Shop or Repair Shop.

GOODELL-PRATT COMPANY  
*Toolsmiths*  
GREENFIELD MASS., U.S.A.

## TOOLS

for shop, factory, garage and home, many high class tools attractively priced in our "Odds and Ends" pamphlet—which is mailed free on request by

**MONTGOMERY & CO., Inc.**, 107 Fulton Street  
NEW YORK CITY

## THE HORSE RASP OF QUALITY

Ask your dealer for the IMPROVED HELLER RASP with keen cutting hard teeth. Made in all patterns and cuts, "Slim," "Light," "Slim Light," and "Fine Cut." Insist on getting the size, kind and cut best suited for your work. It will pay you to give them a trial. New catalogue mailed free on application.

ESTABLISHED IN 1836

**HELLER BROTHERS COMPANY** NEWARK, N. J.

Statement of Ownership, Management, Circulation, etc., required by the Act of August 24, 1912, of The American Blacksmith, published monthly at Buffalo, N. Y., for April 1, 1917:

The Editor is W. O. Bernhardt, Buffalo, N. Y.; the Business Manager, A. W. Bayard, Buffalo, N. Y.; Publisher, The W. F. Wendt Publishing Company, Buffalo, N. Y.

The owners are W. F. Wendt Pub. Co., William F. Wendt, C. H. Schweak and A. W. Bayard, all of Buffalo, N. Y.

Known bondholders, mortgages and other security holders, holding 1 per cent. or more of total amount of bonds, mortgages or other securities; none.

Signed—A. W. Bayard, Business Manager.  
Sworn to and subscribed before me this 23rd day of March, 1917.

(Seal) HERBERT S. WHITING,  
Notary Public.

SEND US YOUR ORDERS

We always have the Stock

## Beals & Company

BUFFALO, N. Y.

Blacksmith's and Wagon Maker's  
Supplies, Iron, Steel, Hardware

LARGEST STOCK IN NEW YORK STATE

## Prentiss Patent Vises

BEST MADE

Large Illustrated Catalog Free

Prentiss Vise Co., Hardware Bld., New York

## VULCANIZERS

Free Instructions and Book with each outfit at Factory or by Mail.

COMPLETE LINE

Tire Vulcanizers, Wrapping Machines and Many Useful Devices for Tire Shops and Factories.

64-PAGE CATALOG ON REQUEST

1894 Established 22 Years 1916

CHAS. E. MILLER  
Anderson Rubber Works  
Factory and Office  
Anderson, Ind., U. S. A.

## The Perfect Power Hammer

Note the difference in construction over other makes.

Extra Long Guides, insuring a direct movement of the ram without any side motion, which causes guides and springs to break on other hammers.

The only Hammer made with a disk attachment with special anvil for sharpening harrow and plow disks.

A recently invented Friction Clutch fitted with Ball Bearings absolutely controls the operation of the Hammer by foot pressure from the lightest tap to the heaviest blow. This ease of operation makes the hammer particularly well adapted for plow work, as you can get as light a stroke as you desire.

Will ship to any responsible party on approval. If not as represented, no sale.

Made in Two Sizes:

3 inch square, 40 lb. ram—shipping weight, 1,150 lbs.  
4 inch square, 80 lb. ram—shipping weight, 1,800 lbs.

Write any Jobber for Prices, or

**MACGOWAN & FINIGAN  
FOUNDRY & MACHINE CO.**  
204 North Third Street  
ST. LOUIS, MO.

TRADE LITERATURE AND NOTES.

(Continued from page 38.)

Company of Wyalusing, Pa.

Every smith knows what it is to make calks by hand and will certainly welcome this handy helper. It not only does all kinds of sharp, blunt and block heeling quicker, easier and better than is possible by hand, but it also starts toe calks without the use of a hammer, removes the worn toes, welds sharp and blunt toes, does steel plugging, and rolls out a perfect finished clip.

Descriptive matter and prices may be had by writing direct to the above address.

Announcement is made that the Dayton Malleable Iron Co. has retired permanently from the manufacture of carriage hardware and fifth wheels. Orders already accepted will be filled as promptly as possible. This action has been made necessary by increased business along other lines. The company recently purchased and equipped a branch foundry at Ironton, O. In addition to making a general line of malleable castings under contract, they will carry in stock such specialty lines as Sarven wheel flanges, concrete construction specialties and specialties for railway use.

(Continued on page 42.)



# NO FLIES!

Blacksmiths know horses will work longer and harder with less effort if flies can't bother them. Sell your farmers and livestock men

## Conkey's FLY KNOCKER

It chases the fly. It's good for cows, too. Helps them turn energy into more and better milk instead of wasting it fighting flies. You can make money selling FLY KNOCKER right in your shop. Gal. \$1.25.

Write for the CONKEY proposition to Blacksmiths.

5002 CONKEY BUILDING The G. E. CONKEY CO. CLEVELAND, OHIO.

### HERE'S THE HANDY HELPER EVERY SMITH NEEDS DAILY

Time, trouble and exasperation can be saved every time you sharpen heel and toe calks, pull off old toes, knock out sickle sections, upset thin iron, bend angles or such other work as hot rasping, steel plugging, turning ordinary mud calks or traveling tires by using this

#### Improved Fuller Foot Vise

No matter how thick the stock this vise, unlike the ordinary foot vise, locks instantly with a light, even pressure. Its great grip is equalled only by a heavy screw vise. Write for complete details or ask your jobber.

C. & E. MANUFACTURING COMPANY MARSHALLTOWN, IOWA

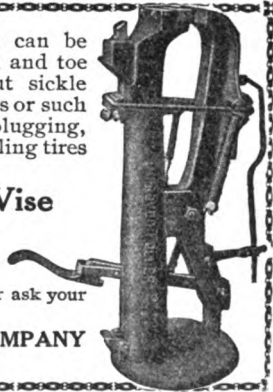

### THERE COMES A TIME IN THE AFFAIRS OF ANVILS



when they simply cease to be useful. Nothing marks the old, unprogressive shop as quickly as a battered and scarred anvil on a rickety base. Put in a new anvil and let your customers know you are keeping your shop up-to-date.

#### ARM AND HAMMER WROUGHT IRON ANVILS

have been the desire of experienced Smiths for years because they stand up under the hardest work, expect to be roughly treated, and are made of the right stuff to last long after the ordinary anvil is out of business. Make the acquaintance of an Arm and Hammer Anvil without delay—write and let us give you the details.

THE COLUMBUS ANVIL & FORGING CO. Columbus, Ohio.

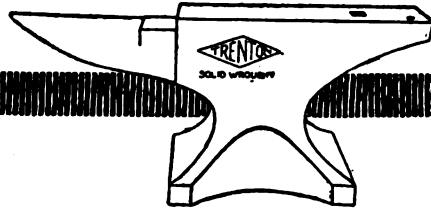

## Cheerful Is The Smith Who Rings A Trenton

There's a somethin' in the spring-time Thoughts o' fishin' an' the like, Makes you fidget 'round a-wishin' You could jes' get out an' hike.

Keeps you thinkin' o' the wild things Jes' out yonder in the brush, An' a-dreamin' o' fish flashin', An' the happy note o' thrush. . . .

—But man, 'tis yours to labor An' sweat by the forge-fire's light; Those thoughts are but joys o' your boyhood, An' not for a man o' might.

So think o' the work that's a-callin' An' a-needin' you right here, And jes' let the song o' your anvil Fill your shop with its helpful cheer.

What a satisfaction to the smith, when he buys an anvil, to feel that it will be his life-long companion—ever cheering his days with its merry ring!

The TRENTON has the ring that lasts—the ring that stands the test of time.

Because it's wrought from pure, live steel—metal with the spring and vitality that "rings like a bell."

Let your jobber show you his line of TRENTONS, or write today for Catalog

The Columbus Forge & Iron Company COLUMBUS, OHIO.

MANUFACTURERS OF THE FAMOUS "INDIAN CHIEF" SOLID BOX VISES.



**CUMMINGS & EMERSON**  
**BLACKSMITH SUPPLIES**  
 Send for net price plow goods catalogue.  
**PEORIA, ILLINOIS**

## WANTED—AN IDEA

Who can think of some simple thing to patent? Protect your ideas, they may bring you wealth. Write for "Needed Inventions," "Patent Buyers," "Millions in Patents," "Patents for Sale," "How to Get Your Patent and Your Money," and other books. **RAEDOLPH & CO., Patent Attorneys, Dept. 794 Washington, D.C.**

**PATENTS HERBERT JENNER,**  
 Patent Attorney and Mechanical Expert, 606 F St., Washington, D. C. Established 1883. I make a free examination and report if a patent can be had and exactly what it will cost. Send for circular.

## PATENTS

**C. L. PARKER**  
 Ex-Member Examining Corps, U. S. Patent Office  
 Attorney-at-Law and Solicitor of Patents  
 American and foreign Patents secured. Trade marks registered. Searches made to determine patentability, validity and infringement. Patent suits conducted. Pamphlet of instructions sent upon request.  
**McGill Building WASHINGTON, D. C.**

**PATENTABLE IDEAS WANTED.** Manufacturers want Owen Patents. Send for free books; inventions wanted, etc. I help you market your invention without charge. **RICHARD E. OWEN, 1 Owen Bldg., Washington, D. C.**

**PATENTS** Write for How to Obtain a Patent. List of Patent Buyers and Inventions Wanted. \$1,000,000 in prizes offered for inventions. Send sketch for free opinion as to patentability. Our four books sent free. **VICTOR J. EVANS, 685 Ninth, Washington, D.C.**

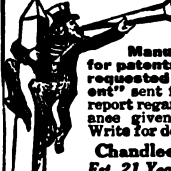

**Inventions Wanted!**  
 Manufacturers constantly writing us for patents. List of inventions actually requested and book "How to Obtain a Patent" sent free. Send rough sketch for free report regarding patentability. Special assistance given our clients in selling patents. Write for details of interest to every inventor.  
**Chandlee & Chandlee, Patent Attorneys**  
 Est. 21 Years 910 F St., Washington, D. C.

**PATENTS** That Protect and Pay  
 Send Sketch or Model for Search.  
**BOOKS and ADVICE FREE**  
**Watson E. Coleman, Patent Lawyer, Washington, D.C.**

**FOR SALE** -- 40 h. p. coal oil engine, 24 k. w. generator, down draft forges, motors, power hammers, drills, hub boring machine, box press tufting machine and a quantity of standard size axles, spring bars, shafts and gear woods. Write us your wants and let us quote you.  
**THE WAL-RIKE PONY VEHICLE CO.**  
 Saint Paris, Ohio

**The Campbell Iron Company**

Distributors of Oxy-Acetylene Welding Equipment and general Blacksmith Shop Supplies.  
 Catalog sent on request.  
**821 CASS AVE. • ST. LOUIS, MO.**

### BALL AND ROLLER BEARINGS.



**THE GWILLIAM COMPANY**  
 The New Departure Service Station  
 New York: 2 Columbus Circle (58th St. at Broadway)  
 Philadelphia: 1314 Arch Street



**You Need This Money Maker**  
 With Skow's Rotary Disc Sharpener you can sharpen cultivator and plow discs of all sizes by cold rolling. Find out why 700 shop owners prefer Skow's sharpener. Write at once.  
**Skow Manufacturing Company**  
 Newton, Iowa, U. S. A.

## WANTED AND FOR SALE

Want and For Sale advertisements, situations and help wanted, twenty-five cents a line Send cash with order. No charge less than fifty cents. The small cost of these advertisements prevents our investigating and guaranteeing them. **WE WILL NOT knowingly accept any but reliable ones.**

**BARGAINS**—Blacksmith Shops, any kind, anywhere. Send for free list. **WESTERN SALES AGENCY, Minneapolis, Minn.**

**WANTED**—Men with Patentable Ideas, write **RANDOLPH & CO., Patent Solicitors, Dept. 289 Washington, D. C.**

**BROTHER**—Accidentally discovered root; cures tobacco habit and indigestion. Gladly send particulars. **C. X. STOKES, Mohawk, Fla.**

**FOR SALE**—24-in. Bentel & Margedant Planer. Cheap. **L. E. BOWMAN, Bentley, Okla.**

**DEBTS COLLECTED QUICKLY!** Established 25 years. **WM. H. DODD, Dept. E, 87 Nassau St., New York City.**

**FOR SALE**—New machines, immediate delivery. 1 7-in. Bench Jointer, \$30.00; 1 9-in. Complete Jointer, \$45.00; 1 12-in. Circular Style Cutter Head for wood table, \$25.00; 1 12-in. Jointer Head and Saw Arbor combined for wood table, \$35.00; 1 Sickle Grinder, double end, \$10.00; 1 Automatic Power Band Saw Filing Machine, \$25.00. For further information and catalogue No. 12, write to **W. L. SHEERWOOD, Kirksville, Mo.**

**FOR SALE**—Blacksmith shop located at Genola, Minn., formerly known as New Pierz, on the Soo R. R. Shop has tools, stock and Gas Engine power in connection, and is situated in good farming district. A bargain if taken at once. For further particulars, address: **MRS. PETER BEKA, R. D. No. 4, Pierz, Minn.**

**FOR SALE**—Blacksmith and Garage, for sale cheap; doing good business year round. Reasons for selling, quitting business. Address: **H. W. STARKBY, Furley, Kansas.**

**FOR SALE**—Power Blacksmith and Automobile repair shop. In as fine farming district as there is in the state. Full outfit of Hand and Power tools for blacksmithing. Fine chance for horsehoer.  
**T. B. HOLT, Maysville, Okla.**

**FOR SALE**—Horseshoeing and general repair shop. Stock and tools. In good location. **CARL ZIEBE, Plainfield, Ia.**

**FOR SALE**—Blacksmith shop, good location in small town. Work for two men. 7-room house, lot. **G. P. THOMAS, Vaughnsville, O.**

**FOR SALE**—Blacksmith shop with full line of tools and stock for sale. In a good business town. Price reasonable. Good terms. For further information, write  
**E. O. WILSON, Murphy, Nebr.**

**FOR SALE**—Horseshoeing shop; will sell all or half interest in splendid shop, located in town of 3,500. Good farming country. Prices, \$1.20 for reset; \$2.00, new; Bars, \$2.00.  
**T. E. BEAVIES, Hicksville, O.**

**FOR SALE**—Blacksmith Shop, 2-story building, 12 living rooms, large cellar, clear. Write **WM. LONHART, 605 Main St., Longmont, Colo.**

## HAVANA STEEL WHEELS



For your Farm Wagon, so as to make it a Low-Down, instead of having to do your work over the sides of a high wheeled wagon. No dry, loose wheels. More and easier work done. Send postal for free catalog of Steel Wheels and Farm Trucks.  
**HAVANA METAL WHEEL CO.,**  
 Box 85 Havana, Ill.

**FOR SALE**—A blacksmith shop, all tools needed in iron and wood work. Gas engine, power hammer, drill, disc-roller, emery and saw under belt. All tools in fine shape. Address: **GEO. E. MEAD, Byron, Nebr.**

**FOR SALE**—Set of Tools and material of our carriage shop at one-half their real value. Smith shop, 80 x 75, for rent, very old stand, only one block from main street corner.  
**JACKSON BUGGY WORKS, Columbus, Ind.**

**FOR SALE OR TRADE**—One of the best equipped shops in the county. Trip hammer and turning lathe, plenty of work all the year round. 5-room house. A good barn and 5 acres of the best land. Well improved. Will trade or sell for a good farm in Idaho, Washington or Montana. Address:  
**A. H. BLUM, Cameron, Idaho.**

## TRADE LITERATURE AND NOTES.

(Continued from page 40.)  
 Many of our readers are making good money by handling spring replacement work on both pleasure and commercial cars.

We wish to call their attention as well as other readers who are not doing this work to the advertisement of the Triple Action Spring Co., Chicago, Ill., appearing in this issue. This firm inform us that they are able to furnish every kind of spring for every make of car since 1903, regardless whether the manufacturer is out of business or not.

They are especially noted for the prompt service given. All springs ordered are shipped the same day, as over 40,000 springs are carried in stock at all times.

They also offer to furnish without charge an attractive rack for sample springs, and will be glad to give our readers further information about this.

We would suggest that you write for their catalog listing, types, dimensions, and sizes of springs for every car. This will gladly be mailed free on request.

## NEW BOOK DEPARTMENT

Manuel for Engineers Published by University of Tennessee Knoxville. 220 Pages, Vest Pocket size, Bound in Black Leather, Price \$5.00.

This little book for engineers and business men has passed through the 20th edition. It is filled with tables and other data, beginning with a metric conversion table which includes tables giving the area and circumferences of circles for diameter from one tenth to one hundredth advancing by tenths. It also contains a table of squares, cubes, square root, cube root, and areas of square and round bars, the weight of sheets of wrought iron, steel, copper and brass, also earthwork tables, interest tables, wiring tables, wire rope tables and information along similar lines. The metal worker will find considerable of value and interest to him in this little book, and with the price set as low as \$5.00 he can hardly afford to do without it.

**When you write to advertisers in reference to anything advertised here, please mention The American Blacksmith.**

**"Bay State" Carriage and Tire Bolt Ratchet Wrenches**  
 Labor Savers!  
 Money Savers!  
 Three Sizes Take Hex and Square Nuts  
 Ask Your Dealer  
**GEO. A. CUTTER, Sales Agent, Taunton, Mass.**





**CURRENT HEAVY HARDWARE PRICES.**

The following quotations are the lowest prices generally prevailing throughout April, 1917. They are subject to change without notice, and higher prices are charged according to quality, specification and other conditions.

There seems to be a lull in general advances for the time being, but it is the opinion of authorities that all goods will go sky-high shortly.

Plow goods have climbed a half-cent in almost every item.

Shoes and Calks seem steady, but manufacturers report a continually advancing market on raw materials.

Business is booming and the demand for goods of all kinds during the month of April was very good.

**Horse Shoes—**

All Iron Shoes	.....\$5.75
Steel Shoes	..... 5.75
No. 0 and No. 1, 25 cents extra.	15 cents per keg additional charged for packing more than one size in a keg.
Mule Shoes	.....
X. L. Steel Shoes	.....
Countersunk Steel Shoes	.....\$6.55
Tip Shoes	.....
Goodenough, heavy	.....
Goodenough, sharp	.....
Toe Weight, pr.	..... .25
Side Weight, pr.	..... .25
E. E. Light Steel	..... 6.30
Steel Driving	.....
O. O. Mule Shoes, extra	.....

Anvils .....\$1.75 & \$1.85

**Merchant Bar Iron—**

\$4.00 rates, full extras, and 20 cents per 100 pounds extra for broken bundles.

**Steel Bars—**

\$4.00 rates, full extras.

**Toe Calks—**

Blunt	.....	Per Box
Sharp	.....\$1.90	
	..... 2.15	

**Screw Calks—**

5-16	3/4	7-16	1/2	5/8	
Blissard M	\$20.00	\$20.00	\$22.00	\$22.00	\$24.00
Sure Grip M	20.00	20.00	22.00	22.00	24.00
Bl Diam. M	20.00	20.00	22.00	24.00	24.00
Red Tip M	22.00	22.00	24.00	24.00	26.00
Rowe, Jr. M	20.00	20.00	22.00	22.00	24.00
King Pt. M	22.00	22.00	24.00	24.00	26.00

**Plow Goods—**

	Soft	Solid	
	Center	Cast	Crucible
Blank Shares	.....\$1.18	.....\$1.18	.....\$1.14
Landside Plates	..... .18	..... .18	..... .14
Lister Lays—Triangle	..... .23	..... .15	..... .17
Lister Lays—V-Pattern	..... .26	..... .15	..... .17
Lister	.....	..... .17	.....
Mould Boards	..... .21	..... .14	..... .15
Cult. Shov. Blanks	..... 2.25	..... 1.40	..... 1.70
(5x5 1/2 x 10 1/2)			

**Hickory Lumber—Per Foot—**

1 to 2 1/2	.....\$ .10
1 1/2 to 4 1/2	..... .12

**Ash and Oak Lumber—Per Foot—**

1—1 1/2	.....\$.08	2 1/2—3	.....\$.09
1 1/2—2	......08 1/2	3 1/2—4	......10

**Yellow Poplar Lumber, Per M. Feet—**

	8 to 12	13 to 17	18 to 24
3/4"	.....\$75.00	.....\$75.00	.....\$85.00
1"	.....75.00	.....78.00	.....90.00
1 1/4"	.....78.00	.....85.00	.....95.00
1 1/2"	.....85.00	.....90.00	.....114.00
1 3/4"	.....85.00	.....90.00	.....114.00

**Rough Hickory Axles—**

3 x 4 x 6 ft.	.....\$ .70
3 1/2 x 4 1/2 x 6 ft.	..... .95
4 x 5 x 6 ft.	..... 1.20
5 x 6 x 6 ft.	..... 2.25
4 x 5 x 6 1/2 ft.	..... 1.75
4 1/2 x 5 1/2 x 7 ft.	..... 2.30
5 x 6 x 7 ft.	..... 2.80
5 x 7 x 7 ft.	..... 3.40

**Finished Hickory Axles—**

For 2 1/2 and 2 3/4 Skeins	.....\$ .95
For 3 Skeins	..... 1.38
For 3 1/2 Skeins	..... 1.48
For 3 3/4 Skeins	..... 1.68
For 4 Skeins	..... 1.90
For 4 1/2 Skeins	..... 2.10

**Rough Oak Bolsters—**

8 x 4	.....\$ .36	4 x 4 1/2	.....\$.40	x12 x 14	.....\$1.55	x16	.....\$1.75
4 x 4	..... .60	4 x 4	..... .70	2.20	2.55	3.00	
5 x 6	..... 1.00	1.20					

**Finished Bolsters—**

2 1/2 and 3 1/2	..... 56c
3 1/2	..... 65c
3 3/4	..... 92c

**Rough Oak Wagon Tongues—**

4 x 4, 2 x 4 12 and smaller	.....\$1.15
-----------------------------	-------------

**Finished Oak Wagon Tongues—**

3 1/2 and smaller	.....\$1.85
3 3/4	..... 1.45
4	..... 1.55

**Two-Inch Sawed Hounds—**

Tongues	..... 88c
Front	..... 44c
Hind	..... 55c

**Wheels—**

0 to 71-inch. A. & B. Grades	..... 50-5%
C. Grades	..... 45-5%
D. Grades	..... 45 %
Tiring—1 1/4 x 3/4" stocks	..... 20%
factory	..... 25%
Screws—1 1/4" Thread and less	..... 37 1/2%
Rivets—1 1/4" Thread and less	..... 37 1/2%
Boring or Boxing less than 10c lots	..... 40%
Boring or Boxing 10 sets or more of one size	..... 60%
Priming Wheels, net	..... 25c
Oiling, not tired, set	..... 20c
Allowance of 25 cents per set on all special tired wheels with three or four piece rims.	
Oiling, not tired, No. 17 to No. 89	..... 25c
Oiling, No. 45 and larger	..... 40c

**Special Tired Wheels—"F" Grade—3 or 4 piece Rim—**

0 3/4 x 1 1/4"	.....\$ 8.60	9 1 1/4 x 1 1/4"	.....\$11.57
1 1/4 x 1 1/4"	..... 8.99	9 1 1/4 x 5-16"	..... 12.48
8 1 x 1 1/4"	..... 9.55	18 1 1/4 x 5-16"	..... 14.78
8 1 x 5-16"	..... 10.40	18 1 1/4 x 3/4"	..... 15.75

**Cupped Oak Hubs—**

10 x 14	.....\$3.30	7 x 8 x 9	.....\$1.80
11 x 14	..... 4.20	7 x 9 x 10	..... 1.50
11 x 15	..... 4.50	8 x 9 x 10	..... 1.55
11 x 16	..... 5.10	8 x 10 x 11	..... 1.80
12 x 16	..... 5.75	9 x 10 x 11	..... 1.95
12 x 17	..... 6.30	9 x 11 x 12	..... 2.00
18 x 18	..... 7.00	10 x 12 x 13	..... 2.00
		11 x 13 x 14	..... 4.20
		12 x 14 x 15	..... 5.10

**Rough Sawed Fellos—**

1 1/2 x 2"	.....\$1.65	2 x 2 1/2"	.....\$1.85
1 1/2 x 2 1/4"	..... 1.75	2 1/2 x 2"	..... 3.50
1 1/2 x 2 1/2"	..... 1.85	3 x 3"	..... 5.25
3 x 3 1/2"	.....\$5.75		

**Ironed Poles, White, XXX**

1 1/2 x 2 1/2" No. 2	.....\$5.50
2 x 2 1/2" No. 3	..... 5.50

**Ironed Shaft, White, XXX—**

1 1/2 x 2" and smaller	.....\$2.50
1 1/2 x 2"	..... 1.75
1 1/2 x 2 1/2"	..... 3.55

**Farm Wagon Bows—**

Round Top, 1/2 x 2"	.....\$ .50
Flat Top, 1/2 x 2"	..... .75
Round Top, 3/4 x 2 1/2"	..... 1.85

**Standard Size Piano Bodies with Seats—**

Each	.....\$5.00
------	-------------

**Plow Beams**

1 Horse	.....\$ .60
2 Horse	..... .85
3 Horse	..... 1.30

**Spokes and Rims—**

Oak and Hickory Spokes, 50% on Weiss & Lesh List No. 8.	
Finished Rims—XX—1 1/4"	.....\$1.75
Finished Rims—XX—1"	..... 1.65
Oak Rims—Discounts	..... 40-10%
Hickory Rims	..... 40%

**Wagon Neckyoke Woods—**

Keller & Tamm's List—Discount	..... 25%
Wagon Whiffletree Woods—All grades—	
Keller & Tamm's List Discount	..... 25%

Oval Plow Dbl'trees—Flat Plow Dbl'trees—	
2 1/2 x 36" ..\$1.60	1 1/2 x 3 1/2 x 42" ..\$2.75
2 x 40" .. 2.40	

**Wagon Evener Woods—**

2 x 4 and 2 x 4 1/2—Keller & Tamm's List—	
Discount	..... 30%
Larger	..... 25%

**Buggy Evener Woods—All Grades—**

Keller & Tamm's List—Discount	..... 25%
-------------------------------	-----------

**Buggy Whiffletree Woods—**

Mixed Second Growth and Second Growth—	
Keller & Tamm's List—Discount	..... 25%
Buggy Neckyoke Woods—All Grades	
Keller & Tamm's List—Discount	..... 25%

**"DUPLIX" BOLT DIE STOCK SETS**

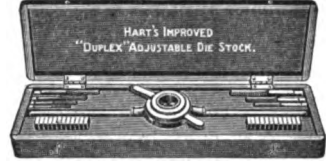

They contain dies that adjust without a wrench and require no reversing after cutting.

THE HART MFG. CO.  
2325 E. 20th St. Cleveland, Ohio

**Horse Shoe Bar Iron**

MADE BY

**The Milton Mfg. Company**

**MILTON, PENN'A**

Is of Superior Strength and Quality. We can prove it. Write us.

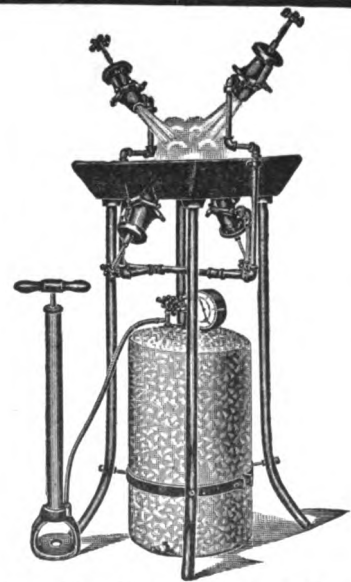

**Best Gasoline Brazing Forge**  
IN THE WORLD

Thousands sold in last ten years. Four sizes. Send for catalog.

The National Rubber & Specialties Co.  
4433-39 Chickering Ave., Winton Place, Cincinnati, Ohio.



**Simonsen Kold Kutter No. 1**  
is the handiest tool you could place on your bench. Made entirely of steel yet low in price. Will cut cold 1/2 x 2 or 1/2 x 6 in. mild steel. Write for our circular K. and learn all about this bench shear.

**SIMONSEN IRON WORKS.**  
Sioux Rapids, Iowa, U. S. A.

**"GEARS AND WAGONS"**

**Selle Gears**

A quarter of a century of success has placed "Selle Gears" and Wagons in the hands of the largest wagon users in the world. Express and Transfer Companies, Department Stores, Fire Departments, etc.; specify "Selle Gears" and will take no other after once tried.

230 page catalog free  
THE AKRONSELLE CO. Akron, Ohio





**BUY ON YOUR OWN TERMS**

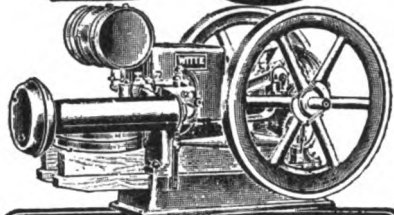

I Have NOW made it possible for any worthy, creditable man to buy a High Grade WITTE Engine on practically his own terms.

**NO MONEY DOWN**  
Cash, Payments or Deposit

No need for any person who needs reliable power, to go without. I will sell you a high grade WITTE Engine on practically your own terms—guarantee the engine you buy for a term of five years—prove the value of the WITTE engine you select by allowing 90 days use and test under your own working conditions. Choice of engines, Gasoline or Kerosene. Can ship same day order is received. Write for latest WITTE prices, and my Free Book, "How to Judge Engines," containing illustrations of the Witte Factory and other interesting matter, showing how I save you \$25 to \$100. A post card brings it.—ED. H. WITTE, Pres.

**WITTE ENGINE WORKS**

1764 Oakland Avenue, Kansas City, Mo.  
1764 Empire Bldg., Pittsburgh, Pa.

Here's Your Big Helper

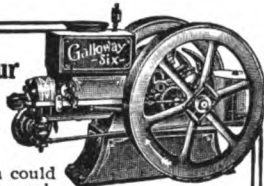

No two men could speed up the work and produce as much **1 1/2 H. P. - \$26.75** new profits for you as **6 H. P. - \$98.75** a Galloway Masterpiece Engine. It's the first essential to greater success. And you can take it NOW no matter what your ready capital by using one of the six special plans explained in my new 250 page catalog.



Once you use a Galloway with its heavy weight, long stroke, large bore and five year guarantee you wouldn't consider any other engine. Put it to work for you now and watch your shop leap ahead. Write for those special propositions AT ONCE.

**WM. GALLOWAY, Pres.**  
The William Galloway Company  
925 Galloway Station,  
Waterloo, Iowa.

**Increase Your Shop Profits**

Don't turn down profitable auto repair jobs because you are afraid to tackle them.

Learn auto repairing from practical instructors.

Your increased profits will pay for the course many times over.

**THE NEBRASKA AUTOMOBILE SCHOOL** offers a simple, easy-to-learn course which will give you a thorough, practical knowledge of automobile repairing in the space of only a few weeks.

Write for catalog and letters from our graduates.

**Nebraska Automobile School,**  
2026 Farnam Street,  
OMAHA,  
Nebraska.



**WONDER DISC SHARPENERS**

**SAVE 1/2 THE TIME AND ALL THE LABOR**

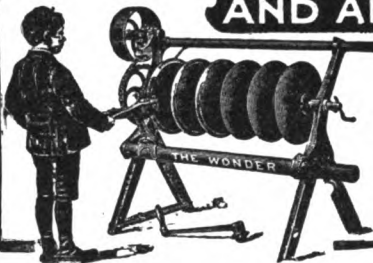

THE WONDER is the only machine adjusted to all conditions.

- Can shear any part of edge to any level.
- Can shear back from edge as far as required.
- Can use tool on either side of disc.
- Can shift from one disc to another.
- Can do all this without the turn of a set screw or nut, is a positive feed, automatically adjusts itself to wobbling or bent discs; knives made of best grade selftempered steel, will last a lifetime for hand and power. For prices, write to your jobber or

**A. E. DURNER, Manufacturer**

Main Office: Evansville, Wisconsin, U. S. A.

Made in Evansville, Wis., and Brandon, Man., Canada.



**A Good Grip**

on the horse-shoe business is best secured by using the celebrated **DIAMOND Line**

because it stands pre-eminently alone in the drive calk field in—

- Perfection of Design
- Superior Hardness and Toughness of Materials
- Accuracy of Calk Fit
- Maximum of Long, Hard Wear

We have a calk and shoe for every purpose. Retailed only through horse-shoers.

**DIAMOND CALK HORSE SHOE CO., Duluth, Minn.**

**Take the Sure Road to Extra Profits**

Strike out for more money by all means but follow the safe, sure path of woodworking—the way thousands of Blacksmiths have widened their business and doubled their profits. You can do it with equal success provided you have the complete

**FAMOUS WOODWORKER**

Easy to Use—Easy to Buy

No great investment required. In fact no investment at all—as you can install a Famous and let it pay for itself. Priced as low as \$125 and sold on a convenient basis every shop owner can accept. Write and give us a chance to explain fully.

**SIDNEY TOOL COMPANY,**  
Sidney, Ohio, U. S. A.



**Parks' Single and Combination Wood Working Outfits**

We were the originators of the Circular Saw, Band Saw, Jointer Combination; our latest improvement is the 6 in. Jointer with undercut attachment for sizing material—joints by passing material over cutter head and sizes it by passing it back under the cutter head. All machines ready for instant use.

Machines are made in large quantities which enable us to sell at lowest prices and make immediate shipment.

Write for Catalog

**Parks Ball Bearing Machine Co.**  
4100 Fergus St., Cincinnati, Ohio

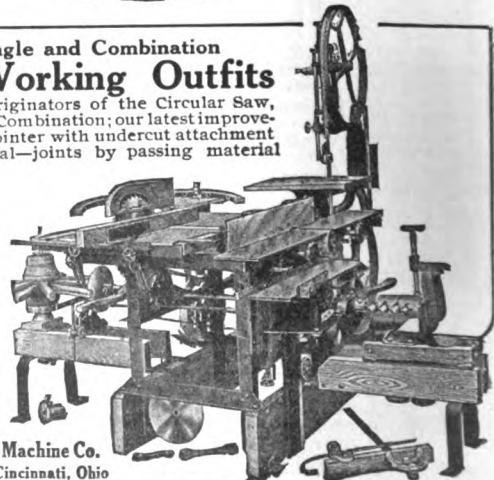

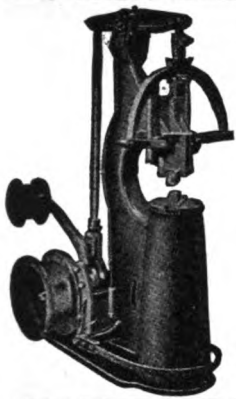

### BETTER THAN THREE SLEDGE HAMMERS

Little Iowa Power Hammer No. 3

No three men can hammer out as much work as this easily operated, powerful hammer. And it has an even stroke, and accuracy impossible to attain by human efforts.

Powerful 35-pound hammer head with a total weight of 850 pounds and a compact base, 22 inches by 38 inches. Guaranteed to satisfy. If it fails, send it back at our expense. We'll refund your money. Price, \$75.00. Send for descriptive booklet.

Every United States jobber represents us. Canadian Agent: D. Ackland & Son, Ltd., Winnipeg, Can. Agent for Montevideo-Uruguay, Casco en Pando: Ambrosia Bertolotti.

MODERN SALES CO.

Hampton, Iowa U. S. A.

## "All Roads Are Good Roads"

Properly tired, riding comfort as well as longer life is assured to the vehicle.

Vehicle makers are a unit in support of this argument.

Comfort, protection to the vehicle and style are three contributing elements which keep Firestone Carriage Tires in the forefront of popular approval. The bulk good appearance demands, together with the light weight good rubber insures, clinch the argument in their favor.

FIRESTONE TIRE & RUBBER CO.  
Akron, Ohio Branches and Dealers Everywhere

# Firestone

## CARRIAGE TIRES

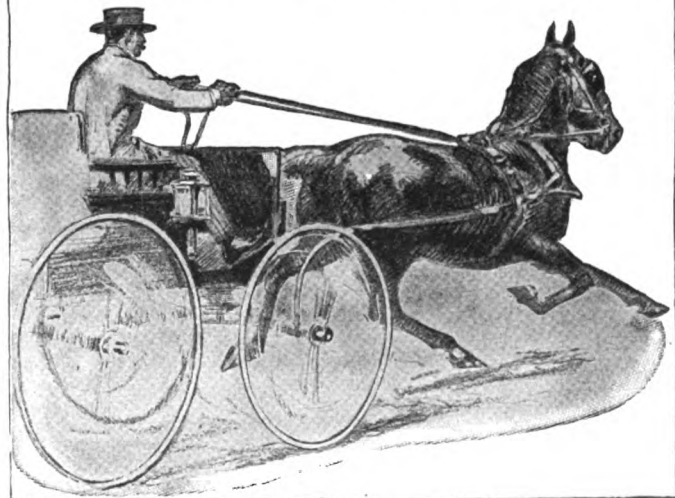

## For REAL MONEY

EVERY Day of the Year

the wise Smith installs this Famous Woodworker. With this complete machine every kind of wood-working job is open to you—and there is good money in every one.

### USE OUR EASY PAYMENT PLAN

Not only can you obtain a Famous Woodworker for as low as \$125 but you can also arrange a series of easy payments. Don't go without a Famous simply because you don't happen to have the ready cash.

Free Circular—telling all about the several Famous models and their attachments—will be sent gratis if you will write today.

SIDNEY TOOL COMPANY

DEPT. 14,

SIDNEY, OHIO, U. S. A.

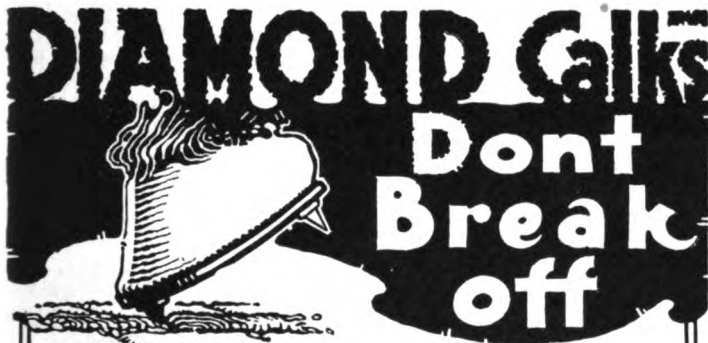

because they're made of the hardest and toughest tool steel produced—they absolutely fit in the calk hole—don't loosen in the shoe, or fall out.

### Diamond Calks

are made for every purpose, and in different sized blades and a diamond is on the end of every shank. Retailed only by horseshoers.

Ask for Catalog.

DIAMOND CALK & HORSESHOE CO.,

DULUTH, MINN.

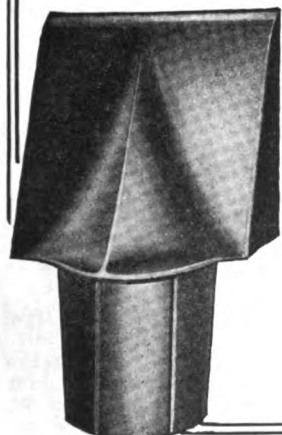



# Genuine giant grip Calks

## TRADE LITERATURE AND NOTES

In designing Torit Welding Apparatus advertised on another page in this issue, the Evleth-Lindsay Co., St. Paul, Minn., has paid special attention to the problem of thoroughly mixing the two gases and so avoiding dangerous and bothersome flash-backs. A small mixing chamber is provided to insure a proper mixture delivered to the nozzle, and that this mixture will always be uniform.

This is only one feature of Torit Apparatus which is offered to American Blacksmith readers at a reasonable price—although the manufacturers assure us that only the very highest grade materials and most advanced ideas are embodied in this equipment.

If you have not taken up Oxy-Acetylene Welding we would suggest that you write for circular the above firm offers to send free. If you are now handling welding, this catalog will also be of interest to you—as the Evleth-Lindsay Co., handle a full line of welders' supplies, and their torches embody ideas which should be of interest to all welders.

## THOUSANDS OF DUPLEX SPRING SYSTEMS FOR FORDS BEING SOLD

Users loud in their praise of Perfect Service Rendered

"Perfect Service" that the keynote of the selling success of any mechanical device, that buyers—Ford users—will obtain perfect service in the action of the Duplex Cantilever System is assured by the fact that Duplex Springs have been developed along strictly scientific lines of construction and are constructed from the highest grade of materials best suited to spring use.

The wonderful efficiency of the Duplex System is now a firmly established fact. The enviable position it so securely holds has been won on merit—and merit alone.

### A Long Needed Improvement

It is reasonable to believe that the Duplex System will make the Ford a more popular car than ever before. As it has overcome the rough-riding faults of a light car. Frequently you hear people say, "Oh, the Ford is all right—has a dandy engine—but it is not as comfortable as a heavier car when employed on rutty roads." The Duplex System has wiped out this objection. It renders the Ford as comfortable on any road as the massive, costly types.

This is accomplished—and can be ac-

complished—only through Cantilever formation. While the Duplex System gives the Ford the delightful riding quality of the most expensive models—it is a decidedly economical system in cost—and certainly in use, as it affects an immense saving in repair costs.

Despite the fact that the Duplex System represents a great advancement in spring construction—the price—\$15.00 per set of four—has been kept within the reach of every Ford owner.

The Duplex Co. are to be congratulated on the simplicity of Duplex construction. They have accomplished a wonderful mechanical feat without employment of complicated parts and at least possible expense.

The Duplex System attaches to the regular Ford spring, converting it into a Cantilever design. It gives a complete double spring system, adding five inches to the present span of Ford Springs. All springs and connections are in perfect alignment with each other. There is no friction or sliding to interfere with or hamper full, free action. Their remarkable resiliency—their quality of "give and take" absorbs the jolts and jars—without discomfort to motorist or damage to machine. Their comfort value is, of course, of great worth. Still there is a real, tangible, dollar-and-cent value in safety and savings. In safety—because it abolishes top-heaviness—holds body of car straight when rounding sharp corners or motoring on sloping roads. In saving—because it relieves both car and tires from stress of road strain—not only keeping the car in service longer but also lessening upkeep costs while it is in service.

It would be difficult indeed to find an accessory that contributes more to Ford comfort or affects a greater curtailment in service cost.

The Duplex Co. have issued an interesting booklet, picturing and describing their Cantilever System, also explaining their liberal 30 Day Free Trial offer. Ford owners desiring a copy write the Duplex Cantilever Spring Co., Dept. B 1, 180 N. Dearborn St., Chicago, Ill.

"A Visit With the Firestone Organization, Its Men, Its Factory, Its Branches," is the title of a 10 x 13 inch, forty-page book, issued by the Firestone Tire and Rubber Company, of Akron, Ohio. In this

book are shown pictures of the Firestone branches, which are located in all parts of the country. There is a picture of the large factory at Akron, and a story of the manufacture of rubber tires, is told both in pictures and in text.

Some excellent pictures of the Firestone organization are shown on two large double folding pages in the center of the book. Here also is shown the Firestone Club House and Restaurant which, with its equipment for the enjoyment of every healthy indoor exercise shows that the Firestone Company is very much interested in the welfare of its employees.

The home of the first combination saw machine is the Parks Factory in Cincinnati, and the accompanying illustration shows one of the latest members of their combination family—Park's New Pony Planer Combination.

To equip a shop with a regular planer,

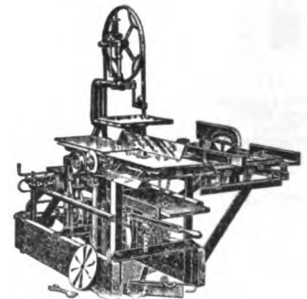

circular saws, band saw, etc., requires a good deal of space and extensive lines of shafting with a large motor or engine.

The combination shown makes an ideal arrangement for any shop, whether large or small. It requires a minimum of space and five horse power is fully sufficient to operate it. All parts of the machine are independent of one another and each part does its work as efficiently as a separate machine of its kind.

With lumber and labor costs soaring skyward in all sections, it will find a wide appeal among all progressive shop owners.

Sly sells out tire holder business to New Era. The New Era Spring & Specialty Company of Detroit, which has been for the past five years the sales department for the Tire Carrier manufactured by the W.

(Continued on Page 48.)



CURRENT HEAVY HARDWARE PRICES.

The following quotations are the lowest prices generally prevailing throughout May, 1917. They are subject to change without notice, and higher prices are charged according to quality, specifications and other conditions. Material which is hard to secure, or which is only to be found in stock in one or two houses, generally commands a premium over current prices.

Advances will be noted in nearly all items, particularly lumber. Compare with last month's report.

Correspondents report business very good and the demand for heavy hardware items which are used by the farmer in putting in his crops seems to be greater than ever, all of which indicates that large crops of all kinds will be planted in all parts of the country.

The late Spring together with heavy rains in some localities have, however, caused a little setback and decreased this demand for seasonal goods, in some sections.

Hardware prices are continually advancing and it is a very hard matter to keep track of the market. A scarcity of hardware items is also evident and it is becoming harder and harder to secure any sort of a prompt shipment on almost any steel item.

Table listing prices for Horse Shoes, including All Iron Shoes, Steel Shoes, Mule Shoes, X. L. Steel Shoes, Countersunk Steel Shoes, Tip Shoes, Goodenough, heavy, Goodenough, sharp, Toe Weight, pr., Side Weight, pr., E. E. Light Steel, Steel Driving, and O. O. Mule Shoes, extra.

Anvils . . . . . \$ .17 1/2 & \$ .18 1/2

Merchant Bar Iron— \$4.75 rates, full extras.

Steel Bars— \$4.75 rates, full extras.

Toe Calks— Per Box

Blunt . . . . . \$2.00

Sharp . . . . . 2.25

Screw Calks—

5-16 % 7-16 1/4 %

Blizzard M \$20.00 \$20.00 \$22.00 \$22.00 \$24.00

Sure Grip M 20.00 20.00 22.00 22.00 24.00

Bl. Diam. M 20.00 20.00 22.00 24.00 24.00

Red Tip M 22.00 22.00 24.00 24.00 26.00

Rowe, Jr. M 20.00 20.00 22.00 22.00 24.00

Ring Pt. M 22.00 22.00 24.00 24.00 26.00

Plow Goods— Soft Center Solid Cast Crucible

Blank Shares . . . . . \$ .18 1/2 \$ .13 \$ .14

Landside Plates . . . . . .18 1/2 .13 .14

Lister Lays—Triangle . . . . . .23 .15 .17

Lister Lays—V-Pattern . . . . . .26 .15 1/2 .17 1/2

Lister . . . . . .17 1/2

Mould Boards . . . . . .21 .14 .15

Cult. Shov. Blanks. . . . . 2.25 1.40 1.70

(5x5 1/2 x 10 1/2)

Hickory Lumber—Per Foot—

1" to 2 1/2" . . . . . \$ .11

4" . . . . . .12 1/2

Ash and Oak Lumber—Per Foot—

1 —1 1/4 . . . . . \$ .09 2 1/2—3 . . . . . \$ .10

1 1/2—2 . . . . . .09 3 1/2—4 . . . . . .10 1/2

Yellow Poplar Lumber, Per M. Feet—

1/2—8" & 9" . . . . . \$ 80.00

1/2—24" & 27" . . . . . 110.00

1/2—34" & up . . . . . 135.00

3/4—6" to 12" . . . . . 82.00

3/4—24" to 28" . . . . . 114.00

1 1/2—18" to 23" . . . . . 95.00

Hickory Wagon

Axles Select Rough . . . . . \$135.00

2 1/2 x 3 1/2 x 6" and up . . . . .

4 1/2 x 5 1/2 x 6" . . . . .

And up . . . . . 160.00

Finished Hickory Axles—

For 2 1/2 and 2 3/4 Skeins . . . . . \$ .95

For 3 Skeins . . . . . 1.38

For 3 1/2 Skeins . . . . . 1.48

For 3 1/2 Skeins . . . . . 1.63

For 4 Skeins . . . . . 1.90

For 4 Skeins . . . . . 2.10

Rough Oak Bolsters—

3 x 4 . . . . . \$1.00

4 x 4 . . . . . 1.20

5 x 6 . . . . . 1.50

Finished Bolsters—

2 1/2 and 3 1/4 . . . . . \$ .60

3 1/4 . . . . . .82

3 3/4 . . . . . 1.00

Rough Oak Wagon Tongues—

4 x 4, 2 x 4, 12 and smaller . . . . . \$1.85

Finished Oak Wagon Tongues—

3 1/2 and smaller . . . . . \$1.50

3 3/4 . . . . . 1.60

4 . . . . . 1.70

Two-Inch Sawed Hounds— Per Pair

Tongues . . . . . 38c

Front . . . . . 44c

Hind . . . . . 55c

Round Edge Steel & Round Edge Iron Tire—

1 1/2 x 1/2 and larger . . . . . \$4.75

R. E. Iron, all sizes . . . . . 4.75

Special Tired Wheels—"F" Grade—3 or 4

piece Rim—

0 3/4 x 1/4 . . . . . \$ 9.00 9 1 1/2 x 1/4 . . . . . \$12.15

1 1/2 x 1/4 . . . . . 9.45 9 1 1/2 x 5-16 . . . . . 13.10

8 1 x 1/4 . . . . . 10.00 13 1 1/2 x 5-16 . . . . . 15.50

8 1 x 5-16 . . . . . 10.90 13 1 1/2 x 3/4 . . . . . 16.50

Plain End Oak Hubs— Cupped Oak Hubs—

10 x 14 . . . . . \$3.60 7 x 8 x 9 . . . . . \$1.40

11 x 14 . . . . . 4.40 7 x 9 x 10 . . . . . 1.65

11 x 15 . . . . . 4.95 8 x 9 x 10 . . . . . 1.70

11 x 16 . . . . . 5.60 8 x 10 x 11 . . . . . 1.95

12 x 16 . . . . . 6.30 9 x 10 x 11 . . . . . 2.15

12 x 17 . . . . . 6.90 9 x 11 x 12 . . . . . 2.20

13 x 18 . . . . . 7.70 10 x 12 x 13 . . . . . 3.30

11 x 13 x 14 . . . . . 4.60

12 x 14 x 15 . . . . . 5.60

Rough Sawed Fellos—

1 1/2 x 2 . . . . . \$1.80 2 x 2 1/2 . . . . . \$3.00

1 3/4 x 2 1/4 . . . . . 1.90 2 1/2 x 2 . . . . . 3.85

1 3/4 x 2 1/2 . . . . . 2.00 3 x 3 . . . . . 5.75

3 x 3 1/2 . . . . . \$6.30

Ironed Poles, White, XXX—

1 1/2 x 2 1/4 . . . . . No. 2 . . . . . \$5.50

2 x 2 1/2 . . . . . No. 3 . . . . . 5.50

Ironed Shaft, White, XXX—

1 1/2 x 2" and smaller . . . . . \$2.50

1 1/2 x 2" . . . . . 1.75

1 1/2 x 2 1/4 . . . . . 3.55

Farm Wagon Bows—

Round Top, 1/2 x 2" . . . . . \$ .60

Flat Top, 1/2 x 2" . . . . . .75

Round Top, 3/4 x 2 1/2 . . . . . 1.35

Standard Size Piano Bodies—

Each . . . . . \$6.00

Plow Beams—

1 Horse . . . . . \$ .60

2 Horse . . . . . .85

3 Horse . . . . . 1.30

Spokes and Rims, Hickory, rounded & bored—

Oak and Hickory Spokes, 40-5% on Weiss & Lesh List.

Finished Rims—XX—7/8" . . . . . \$1.80

Finished Rims—XX—1" . . . . . 2.15

Wagon Neckyoke Woods—

Discount . . . . . 12 1/2 %

Wagon Whiffletree Woods—All grades—

Keller & Tamm's List Discount . . . . . 12 1/2 %

Oval Plow Db'l'trees— Flat Plow Db'l'trees—

2 1/2 x 30" \$1.10 1 1/2 x 3 1/2 x 42" \$3.00

Wagon Evener Woods—

2 x 4 and 2 x 4 1/2—Keller & Tamm's List—

Discount . . . . . 15 %

Larger . . . . . 12 1/2 %

Buggy Evener Woods—All Grades—

Keller & Tamm's List—Discount . . . . . 12 1/2 %

Buggy Whiffletree Woods—

Mixed Second Growth and Second Growth—

Keller & Tamm's List—Discount . . . . . 12 1/2 %

Buggy Neckyoke Woods—All Grades—

Discount . . . . . 6 1/2 %

"DUPLEX" BOLT DIE STOCK SETS



They contain dies that adjust without a wrench and require no reversing after cutting.

THE HART MFG. CO.

2325 E. 20th St. Cleveland, Ohio

Horse Shoe Bar Iron

MADE BY

The Milton Mfg. Company

MILTON, PENN'A

Is of Superior Strength and Quality. We can prove it. Write us.



Best Gasoline Brazing Forge IN THE WORLD

Thousands sold in last ten years. Four sizes. Send for catalog.

The National Rubber & Specialties Co. 4433-39 Chickering Ave., Winton Place, Cincinnati, Ohio.

"GEARS AND WAGONS"

Selle Gears

A quarter of a century of success has placed "Selle Gears" and Wagons in the hands of the largest wagon users in the world.

Express and Transfer Companies, Department Stores, Fire Departments, etc.; specify "Selle Gears" and will take no other after once tried.

230 page catalog free

THE AKRONSELLE CO. Akron, Ohio

Simonsen Kold Kutter No. 1

is the handiest tool you could place on your bench. Made entirely of steel yet low in price. Will cut cold 1/2 x 2 or 1/2 x 6 in. mild steel. Write for our circular K and learn all about this bench shear.

SIMONSEN IRON WORKS. Sioux Rapids, Iowa, U. S. A.





## Butterfield's Screw Plates

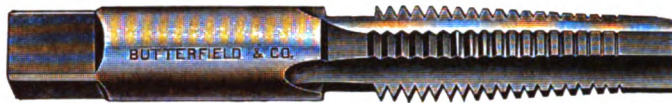

We do not claim to be the oldest manufacturers of Screw Plates. We are not sure that this is any distinction. Our claims for the superiority of our TAPS and SCREW PLATES are based on actual performance. The rapid growth of our business, is proof positive of the excellence of our product. Be sure you ask for BUTTERFIELDS, and take no substitute.

NEW YORK STORE  
126 Chambers Street

BUTTERFIELD & CO. DERBY LINE, VT., U.S.A.

## HAVE YOU ANY FRIENDS

in the smithing craft whose good will you especially esteem? There is no better way of showing them your friendship than by a small gift; there is no gift which such a friend would appreciate more than a year's subscription to *The American Blacksmith*. It will remind him of you constantly for an entire year, and furnish him with interesting, valuable reading which he will greatly like. If you have any friends who are not subscribers, write us for terms of subscriptions for them.

AMERICAN BLACKSMITH CO.  
P. O. Box 974, BUFFALO, N. Y., U.S.A.

## Parks' Single and Combination Wood Working Outfits

We were the originators of the Circular Saw, Band Saw, Jointer Combination; our latest improvement is the 6 in. Jointer with undercut attachment for sizing material—joints by passing material over cutter head and sizes it by passing it back under the cutter head. All machines ready for instant use.

Machines are made in large quantities which enable us to sell at lowest prices and make immediate shipment.

Write for Catalog

Parks Ball Bearing Machine Co.  
4100 Fergus St., Cincinnati, Ohio

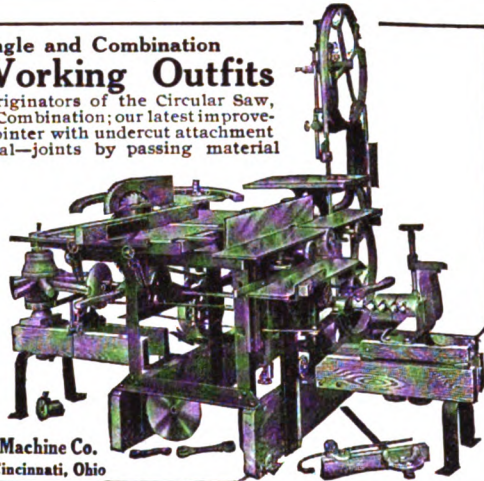

## Bermo Welding Plants

OXY-ACETYLENE

13 years successful record.

Guaranteed. Write for Catalog and Easy Terms.

\$25 to \$250

Bermo Supply Co., Omaha, Neb.

Every time you don't find what you want in "Our Journal" please tell us about it.

American Blacksmith Co.

### TRADE LITERATURE AND NOTES.

(Continued from Page 46.)

W. Sly Company, Cleveland, has purchased this part of the Sly Company's business, patents recently adjudicated, good will, equipment and stock.

The deal also included the taking over of the manufacturing of a Tire Lock that both Sly and the New Era have been making and places the latter in a strong position to serve the jobbing trade as one of the prominent accessory manufacturers.

The New Era will combine the Tire Holder product with their Shock Absorber and Bumper plant, either in Detroit or Grand Rapids. The main sales office, however, will remain in Detroit.

### NEW BOOKS

"A System of Account for Retail Merchants", also "Fundamentals of a Cost System for Manufacturers." These two publications in pamphlet form have been issued by the Federal Trade Commission. They are sent to manufacturers and merchants throughout the United States, upon application to the Federal Trade Commission, Washington, D. C.

The pamphlet describes simple book-keeping and cost-keeping accounting systems and should be of considerable interest and value to blacksmiths, wagon and carriage workers, automobile repair men and general smiths. The various books of accounting and statements are carefully explained, a number of forms are shown, and accounting for retail merchants and small manufacturers is carefully explained.

We believe that every one of THE AMERICAN BLACKSMITH readers should secure a copy of the booklet detailing a cost system for the manufacturer.

"Plain and Ornamental Forging," by Ernst Schwarzkopf, Instructor at Stuyvesant High School, New York City, 267 pages, 228 illustrations. Bound in cloth, \$1.50. John Wiley & Sons.

This book by Mr. Schwarzkopf, is an excellent one on the subject of Plain and Ornamental Forging. It covers the subject thoroughly, and begins with a general description of the Properties of Iron and then goes into the details of the forge and its equipment, and the tools that are used by the blacksmith. Chapter four details a number of practical exercises for the beginner, while chapters five, six and seven take the reader by easy stages into the more complicated and more intricate work of forging and smithing. Steel and its properties are then explained and the details of Annealing, Hardening, Tempering are then gone into. There's also a chapter on the making of tools.

The pages on Ornamental Forging show some excellent examples of leaf, scroll and other ornamental work. These are, of course, explained in detail. The appendix contains a number of practical items, such as the Bending of Brass, Bronze and Copper Pipes, Straightening Sheet Metal, Drilling Square Holes; Coloring Brass and Bronze, Brazing, Soldering, Welding Aluminum, Making a Screw-Driver and it also contains a number of practical tables for the practical smith.

Altogether, this book by Mr. Schwarzkopf is an excellent volume for the practical blacksmith. As he will find answers to a great many questions which puzzle him in his daily work, "Plain and Ornamental Forging" is a book that should be in the library of every practical blacksmith.

The Norman W. Henley Publishing Company announces the publication of three new books by Victor Page. They are all

especially timely and should be well received by all who are interested in the automobile and tractor.

Following is a brief description of each, which may be secured through THE AMERICAN BLACKSMITH Book Department, at the price stated.

### HOW TO RUN AN AUTOMOBILE

For the man with his first car, or the shop repairman who wants to learn more about the automobile.

This treatise gives concise instructions for starting and running all makes of gasoline automobiles, how to care for them, and gives distinctive features of control. Shows the control groups of all popular makes of automobiles and describes every step for shifting gears, controlling engine, etc.

It is impossible to get the greatest efficiency out of a car until you know every point in running, caring for and adjusting the machine. In this new book just the problems you are up against are solved in a way that you can easily understand, and so that you can immediately turn to your car and apply the knowledge.

A book every one has been looking for. Fills a real need among motorists, dealers, chauffeurs, repairmen and all who must handle different makes of cars.

178 pages, 72 engravings. Everything explained in simple, understandable language. Price, \$1.00.

### THE MODERN GAS TRACTOR

A complete treatise describing all types and sizes of gasoline, kerosene and oil tractors. Considers design and construction exhaustively, gives complete instructions for care, operation and repair, outlines all practical applications on the road and in the field. The best and latest work

(Continued on Page 49.)

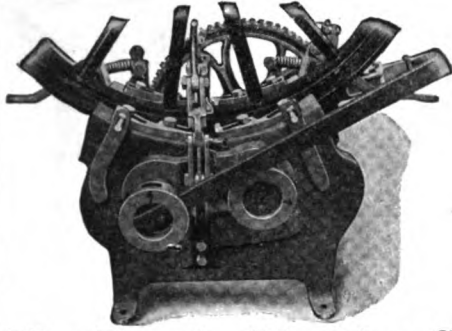

### The Brooks Cold Tire Setter

Sets tires cold on the wheel and is the pioneer edge-grip hand-power cold tire setter. Used and officially endorsed by the United States Government in the Department of War and Interior. Thousands of blacksmiths in the U. S. consider it the most profitable machine in their shop. We build both hydraulic and lever cold tire setters. The Brooks does the work quicker and better than any other cold tire setter on the market and should be in every blacksmith and carriage repairer's shop. Write for catalog and prices.

We are also manufacturers of the latest improved Oxy-Acetylene Welding machines and generators, equipped with our famous Safety Flash Back Valve. It prevents explosions.

We also build Welding Outfits to be used with cylinder gases.

Our catalog will interest you and is free for the asking.

The Brooks Machine Company,

Wichita, Kansas



**Prentiss Patent Vises**  
BEST MADE  
Large Illustrated Catalog Free  
Prentiss Vise Co., Hardware Bld., New York

"NEW EASY" 4 Sizes **BOLT CLIPPERS** "EASY" 2 Sizes

THE GENUINE TOOL



KNOWN AND PREFERRED EVERYWHERE

H. K. PORTER EVERETT, MASS. U. S. A.

#### TRADE LITERATURE AND NOTES. (Continued from Page 48.)

on farm tractors and tractor power plants. This work is written by a recognized authority on self-propelled vehicles and internal combustion motors. Everything is explained so simply that anyone of average intelligence may obtain a comprehensive knowledge of gas tractor operation, maintenance and repair. Tells how they are constructed and explains fully the reasons for varying designs. Contains special chapters on driving the tractor on field and road, what to expect from tractors in various kinds of work, cost of operation and money-making hints on repairs. It describes all ignition systems, all types of gasoline and kerosene vaporizers and carburetors, latest forms of power plants and installation, clutches, speed changing and reversing gears and all frame parts and their functions. Tells how to tell brake horse-power from drawbar or horse equivalent power, how to make adjustments to power plants, change speed gearing and other parts. Describes tools for tractor repair and gives plans for tractor sheds so they can be used in winter for stationary power or workshops where all repairs may be made. Outlines control systems of leading types and shows simple hitches for working various implements in combination. Describes fully tractors for small farms and orchards as well as types of the largest capacity. All illustrations are plainly marked with all important parts indicated so they may be easily identified. Drawings are simple but in correct proportion. Every illustration has been specially made for this book. Contains 480 pages, folding plates and 204 illustrations. Price, \$2.00.

**THE MODERN GASTRACTOR**

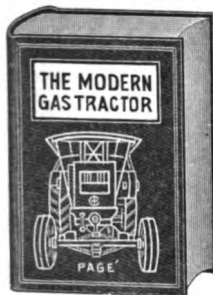

most thorough and authoritative treatise ever published on this subject. It is written in easily understandable, non-technical language so that any one may grasp the basic principles of storage battery action as well as their practical industrial applications. All electric and gasoline automobiles use storage batteries. Every automobile repairman should have a good knowledge of maintenance and repair of these important elements of the motor car mechanism. This book not only tells how to charge, care for and rebuild storage batteries but also outlines all the industrial uses. Learn how they run street cars, locomotives and factory trucks. Get an understanding of the important functions they perform in submarine boats, isolated lighting plants, railway switch and signal systems, marine applications, etc. This book tells how they are used in central stations standby service, for starting automobile motors and in ignition systems. Every practical use of the modern storage battery is outlined in this treatise. 320 pages, fully illustrated. Price, \$1.50.

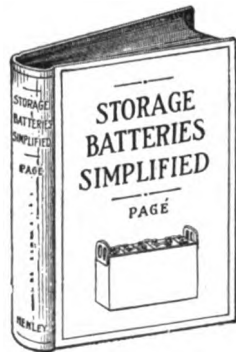

**STORAGE BATTERIES SIMPLIFIED**

After a lapse of nearly half a century, during which time no noteworthy publication on blast furnaces has appeared, Mr. J. E. Johnson, Jr., has written a new, authoritative treatise on the subject, "Blast-Furnace Construction in America."

For the progressive worker in metals, this book will prove highly valuable and interesting as it treats of metals from a rather unique angle and affords the reader a rare insight into metal working on a large scale.

Price, \$4.00 net, direct from the publishers, the McGraw-Hill Book Co., 239 West 39th St., New York City, or through The American Blacksmith Book Department.

W. F. Schaphorst, M. E., Advertising Engineer, ex-instructor in forging in a western college, and author of articles that have been published in American

Blacksmith has established an engineering advertising service office in the Woolworth Bldg., New York City. He solicits business with manufacturers of high grade engineering products.

#### SOME WAR TIME SUGGESTIONS CONCERNING SPRINGS

By H. T. Moore—Spring Designer of Tut-hill Spring Co.

Of the numerous orders that have been coming to us and no doubt to other spring manufacturers, for springs to be used on ambulances or trucks, in active field work or in Red Cross Service, a large percentage show an astonishing amount of carelessness or ignorance on the part of the company ordering. It is the object of this brief article to urge very strongly, that the actual design of springs be left to those best fitted to secure proper results. In other words, inform the spring-maker of the conditions under which the springs are to serve, and leave the actual design to him.

Some pleasure car manufacturers are planning to build ambulances for field work and are attempting to use their standard pleasure car springs. For example, an order was recently received for a number of springs from a well-known manufacturer of pleasure cars, who specified, "Same as previously furnished." Upon investigation it was found that the springs were not to be used on the regular car, but were intended for ambulances in which service a weight nearly double that of the pleasure car body would have to be borne.

Apparently this concern had entirely overlooked the fact that the pleasure car springs would not be at all suitable for the ambulance work. If the spring manufacturer had not questioned the order, but had made up the springs, "as previously furnished," imagine the disastrous results.

In general, ambulance springs should be quite wide, and designed with at least double the ordinary factor of safety, for a broken spring is quite likely to mean the life or death of the sick or wounded. Let the spring manufacturer know all the facts, and let him design the proper springs. He has had experience and knows his business, and therefore should be the best suited to design springs to give maximum riding qualities combined with a proper factor of safety.

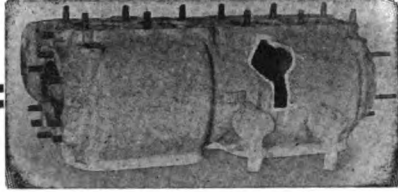

### A Big Profit Made on this Job

A new aluminum crank case like the above would cost over \$100. This one was welded as good as new with a *Torit* *Outfit* at a cost to the welder of only \$3.20—and the welder made a big profit.

There are big money making opportunities in the welding business for shop owners. Broken parts of implements, tractors, autos and other machinery—formerly thrown in the scrap heap can be welded and made as strong as new, in a few minutes.

# TORIT 6300°

Welding, Cutting and carbon removing equipment. Extremely simple, safe and reliable. Though reasonable in price, are made of only the finest material by skilled workmen. Ideal apparatus for either the small or large shops.

#### Write for Catalogue

Decide *now* to investigate possibilities in the welding business by writing for catalogue, describing *Torit* *Equipment*, gladly sent on request.

**The Evleth-Lindsay Company**  
St. Paul, Minn.

A full line of supplies for welders carried and sold at reasonable prices.

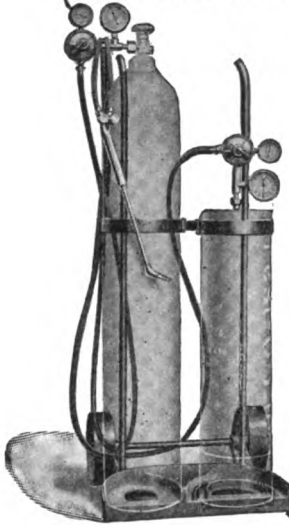

Get the New

# Little Giant

TRADE MARK REG.

## CATALOGUE.

We have just issued a New Catalogue which completely describes our full line of Punches and Shears.

Write for it AT ONCE.

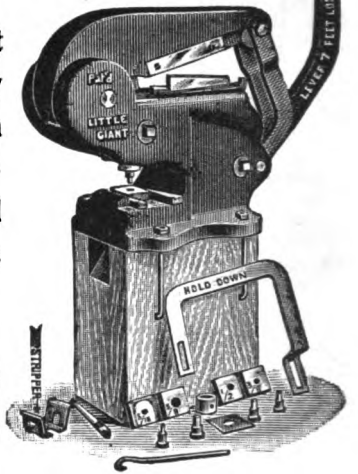

*It will pay you to look it over before buying.*

**Little Giant Punch & Shear Co.**  
210 S. Market St. SPARTA, ILL.

## ONE KICK MIGHT COST

a hundred dollar doctor bill and keep you out of the shop for months—in fact nearly ruin your business. Why take the chance? Make sure such a disaster can't happen to you by simply using

### Barcus Safety Horse Stocks

Entirely different from the old style horse stocks with their bothersome ropes, straps and buckles. All chances for injury are removed by the Safety Foot Clamp—a fortunately discovered automatic device that holds the foot like a vise. Its action is positive, quick and safe—you do not even have to touch the foot or limb of the horse.



The Barcus sells at a price so reasonable no smith can afford to be without the protection of these stocks.

As you value your life and health, as you seek to protect and support your family, do them and yourself the justice of writing for complete information without delay.

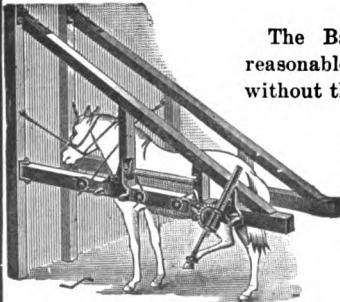

**The Barcus Mfg. Co.,**

Wabash,

Indiana.

## Find Out What Great Profits a Crescent Woodworker Would Make for You

Have you ever seriously considered the extra business you could handle if you had a Crescent Woodworker.

For instance this is the automobile time of the year—if you had a Crescent that would mean many chances to build new bodies or to convert old cars into motor trucks.

This is also the time when farmers are ready to buy hay racks, carts, farm wagons, plow handles, and many other articles you could make in your spare time at good profits if you had the help of a Crescent.

Let us tell you about this special design which has been developed solely for the Blacksmith-Carriage shop. Let us explain our system of attachments whereby you are furnished with only the essential machines at the beginning and can select your attachments as you are sure you need them.

This is information you would be glad to receive—and you would also find the 1916 Crescent catalog a great help. Why not write your letter now?

**Crescent Machine Company,**  
245 Main St.,  
Leetonia, Ohio.

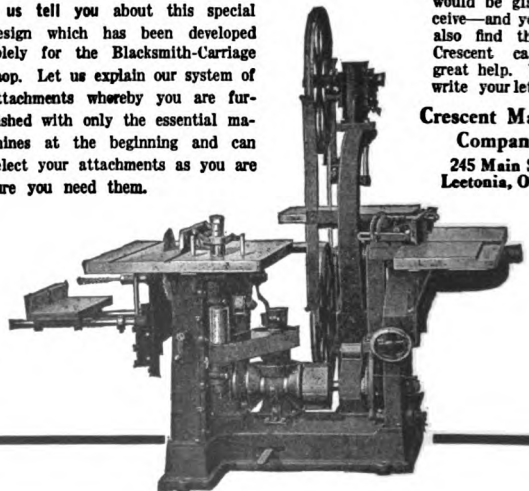



**CURRENT HEAVY HARDWARE PRICES.**

The following quotations are the lowest prices generally prevailing throughout June, 1917. They are subject to change without notice, and higher prices are charged according to quality, specifications and other conditions. Material which is hard to secure, or which is only to be found in stock in one or two houses, generally commands a premium over current prices.

There have been no substantial advances during June, prices seemingly having reached a high level for the time being. Due to the general scarcity of hardware items, however, it is becoming harder and harder to secure any sort of a prompt shipment on almost any steel item.

**Horse Shoes—**

All Iron Shoes	.....\$6.70
Steel Shoes	..... 5.75
No. 0 and No. 1, 25 cents extra.	15 cents per keg additional charged for packing more than one size in a keg.
Mule Shoes	.....
X. L. Steel Shoes	.....
Countersunk Steel Shoes	.....\$6.55
Tip Shoes	.....
Goodenough, heavy	.....
Goodenough, sharp	.....
Toe Weight, pr.	..... .25
Side Weight, pr.	..... .25
E. E. Light Steel	..... 6.30
Steel Driving	.....
O. O. Mule Shoes, extra	.....

Anvils .....\$17 1/2 & \$18 1/2

**Merchant Bar Iron—**

\$4.75 rates, full extras.

**Steel Bars—**

\$4.75 rates, full extras.

**Toe Calks—**

Per Box

Blunt	.....\$2.00
Sharp	..... 2.25

**Screw Calks—**

	5-16	3/8	7-16	1/2	3/4
Blizzard M	\$20.00	\$20.00	\$22.00	\$22.00	\$24.00
Sure Grip M	20.00	20.00	22.00	22.00	24.00
Bl. Diam. M	20.00	20.00	22.00	24.00	24.00
Red Tip M	22.00	22.00	24.00	24.00	26.00
Rowe, Jr. M	20.00	20.00	22.00	22.00	24.00
Ring Pt. M	22.00	22.00	24.00	24.00	26.00

**Flaw Goods—**

Soft Solid Center Cast Crucible

Blank Shares	.....\$18 1/2	.....\$13	.....\$14
Landside Plates	.....18 1/2	.....13	.....14
Lister Lays—Triangle	.....23	.....15	.....17
Lister Lays—V-Pattern	.....26	.....15 1/2	.....17 1/2
Lister	.....	.....17 1/2	.....
Mould Boards	.....21	.....14	.....15
Cult. Shov. Blanks (5x5 1/2 x 10 1/2)	.....2.25	.....1.40	.....1.70

**Hickory Lumber—Per Foot—**

1" to 2 1/2"	.....\$.11
4"	......12 1/2

**Ash and Oak Lumber—Per Foot—**

1 —1 1/4	.....\$.10	2 1/2—3	.....\$.12
1 1/2—2	......10 1/2	3 1/2—4	......13

**Yellow Poplar Lumber, Per M. Feet—**

1/2-8" & 9"	.....\$ 80.00
1/2-24" & 27"	..... 110.00
1/2-34" & up	..... 135.00
3/4-6" to 12"	..... 82.00
3/4-24" to 28"	..... 114.00
1 1/2-18" to 23"	..... 95.00

**Hickory Wagon**

Axles Select Rough	.....\$135.00
2 1/2 x 3 1/4 x 6' and up	.....
4 1/2 x 5 1/2 x 6'	.....
And up	..... 160.00

**Finished Hickory Axles—**

For 2 1/2 and 2 3/4 Skeins	.....\$.95
For 3 Skeins	..... 1.38
For 3 1/4 Skeins	..... 1.48
For 3 1/2 Skeins	..... 1.63
For 4 Skeins	..... 1.90
For 4 1/4 Skeins	..... 2.10

**Rough Oak Bolsters—**

3 x 4	.....\$1.00
4 x 4	..... 1.20
5 x 6	..... 1.50

**Finished Bolsters—**

2 1/2 and 3 1/4	.....\$.80
3 1/4	......82
3 3/4	..... 1.00

**Rough Oak Wagon Tongues—**

4 x 4, 2 x 4, 12 and smaller	.....\$1.85
------------------------------	-------------

**Finished Oak Wagon Tongues—**

3 1/2 and smaller	.....\$1.50
3 3/4	..... 1.60
4	..... 1.70

**Two-Inch Sawed Hounds—**

Per Pair

Tongues	..... 38c
Front	..... 44c
Hind	..... 55c

**Round Edge Steel & Round Edge Iron Tire—**

1 1/2 x 1/2 and larger	.....\$4.75
R. E. Iron, all sizes	..... 4.75

**Special Tired Wheels—"F" Grade—3 or 4 piece Rim—**

0 3/4 x 1 1/4	.....\$ 9.00	9 1 1/4 x 1 1/4	.....\$12.15
1 1/4 x 1 1/4	..... 9.45	9 1 1/4 x 5-16	..... 13.10
3 1 x 1 1/4	..... 10.00	13 1 1/4 x 5-16	..... 15.50
3 1 x 5-16	..... 10.90	13 1 1/4 x 3/4	..... 16.50

**Plain End Oak Hubs—**

**Cupped Oak Hubs—**

10 x 14	.....\$3.60	7 x 8 x 9	.....\$1.40
11 x 14	..... 4.40	7 x 9 x 10	..... 1.65
11 x 15	..... 4.95	8 x 9 x 10	..... 1.70
11 x 16	..... 5.60	8 x 10 x 11	..... 1.95
12 x 16	..... 6.30	9 x 10 x 11	..... 2.15
12 x 17	..... 6.90	9 x 11 x 12	..... 2.20
13 x 18	..... 7.70	10 x 12 x 13	..... 3.80
		11 x 13 x 14	..... 4.60
		12 x 14 x 15	..... 5.60

**Rough Sawed Felices—**

1 1/2 x 2	.....\$1.80	2 x 2 1/2	.....\$3.00
1 3/4 x 2 1/4	..... 1.90	2 1/2 x 2	..... 3.85
1 3/4 x 2 1/2	..... 2.00	3 x 3	..... 5.75
3 x 3 1/2	.....		.....\$6.30

**Ironed Poles, White, XXX—**

1 1/2 x 2 1/4 No. 2	.....\$5.50
2 x 2 1/4 No. 3	..... 5.50

**Ironed Shaft, White, XXX—**

1 1/2 x 2" and smaller	.....\$2.50
1 1/2 x 2"	..... 1.75
1 1/2 x 2 1/4	..... 3.55

**Farm Wagon Bows—**

Round Top, 1/2 x 2"	.....\$.60
Flat Top, 1/2 x 2"	......75
Round Top, 3/4 x 2 1/2"	..... 1.35

**Standard Size Piano Bodies—**

Each .....\$6.00

**Flaw Beams—**

1 Horse	.....\$.80
2 Horse	......85
3 Horse	..... 1.80

**Spokes and Rims, Hickory, rounded & bored—**

Oak and Hickory Spokes, 40-5% on Weiss & Lesh List.	.....
Finished Rims—XX—1/2"	.....\$1.80
Finished Rims—XX—1"	..... 2.15

**Wagon Neckyoke Woods—**

Discount .....12 1/2 %

**Wagon Whiffletree Woods—All grades—**

Keller & Tamm's List Discount .....12 1/2 %

**Oval Flaw Dbl'trees— Flat Flaw Dbl'trees—**

2 1/2 x 30" \$1.10	1 1/2 x 3 1/2 x 42" \$3.00
--------------------	----------------------------

**Wagon Evener Woods—**

2 x 4 and 2 x 4 1/2—Keller & Tamm's List—	.....
Discount	......15 %
Larger	..... 12 1/2 %

**Buggy Evener Woods—All Grades—**

Keller & Tamm's List—Discount...12 1/2 %

**Buggy Whiffletree Woods—**

Mixed Second Growth and Second Growth—	.....
Keller & Tamm's List—Discount...12 1/2 %	.....

**Buggy Neckyoke Woods—All Grades—**

Discount .....6 1/2 %

**"DUPLEX" BOLT DIE STOCK SETS**

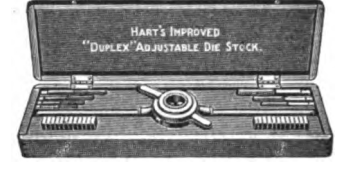

They contain dies that adjust without a wrench and require no reversing after cutting.

**THE HART MFG. CO.**  
2325 E. 20th St. Cleveland, Ohio

**Horse Shoe Bar Iron**

MADE BY

**The Milton Mfg. Company**

**MILTON, PENN'A**

Is of Superior Strength and Quality. We can prove it. Write us.

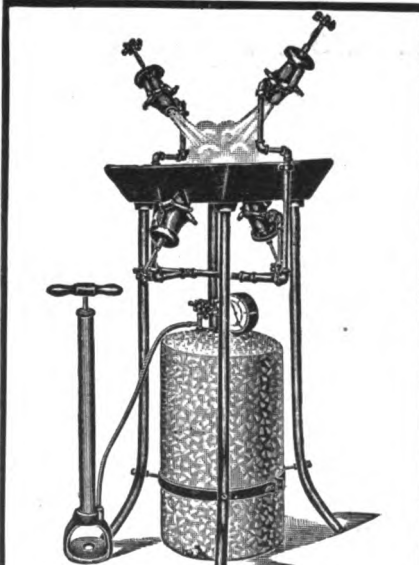

**Best Gasoline Brazing Forge IN THE WORLD**

Thousands sold in last ten years. Four sizes. Send for catalog.

The National Rubber & Specialties Co.  
4433-39 Chickering Ave., Winton Place, Cincinnati, Ohio.



**Simonsen Kold Cutter No. 1** is the handiest tool you could place on your bench. Made entirely of steel yet low in price. Will cut cold 1/2 x 2 or 1/2 x 6 in. mild steel. Write for our circular K and learn all about this bench shear.  
**SIMONSEN IRON WORKS.**  
Sioux Rapids, Iowa, U. S. A.

**"GEARS AND WAGONS"**  
**Selle Gears** A quarter of a century of success has placed "Selle Gears" and Wagons in the hands of the largest wagon users in the world.  
Express and Transfer Companies, Department Stores, Fire Departments, etc.; specify "Selle Gears" and will take no other after once tried.  
230 page catalog free  
**THE AKRON-SELLE CO.** Akron, Ohio





**NOW'S THE TIME YOU WANT YOUR FAMOUS**

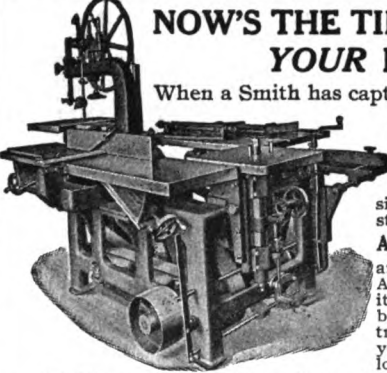

When a Smith has captured about all the shoeing and repairing to be handled he is forced to take up other work if he is going to have a growing business. And the most sensible thing he can do is to install a Famous Woodworker. Accept Our Easy Payment Plan and you can have a Famous AT ONCE and let it pay for itself. It won't take long to build up a big woodworking trade with the Famous. And you can obtain a Famous as low as \$125.

Send for *special circular* and learn about the handy arrangement of the Famous and its many attachments. Write us your address NOW.

**SIDNEY TOOL COMPANY, Dept. 14, Sidney, Ohio, U. S. A.**

**Big Profit Maker for Shop Owners**



Sell and attach **DOTTLE SPRING AND FRAME SUPPORTERS** for Ford Cars. Enable any Ford to carry 2000 lbs. and prevent breaking of rear axle and housings, caused from the rear wheel bumping on housing. Especially desirable for Fords used as trucks, delivery cars and busses, as they increase the carrying capacity over 50%. Improve riding qualities of pleasure cars — preventing excessive body rocking and spring bumping on the housing.

**EASILY SOLD TO EVERY FORD OWNER**

There is no other device made like the **Dottle Spring and Frame Supporters**. You can apply them in a few minutes with a hammer and wrench — no holes to drill.

**Price Complete \$8.00 SET**



A 2000 lb. load on this Ford — Equipped with **Dottle Springs**.

**2 3/4" Clearance**

Write for full information and discounts. Don't overlook this profitable article. Be the first in your section to introduce it to Ford owners and reap the profits. Write today — company will help you get customers.

**THE AUTOMATIC SAFETY TIRE VALVE CO., OWEN BUILDING, DETROIT, MICHIGAN**

**Parks' Single and Combination Wood Working Outfits**

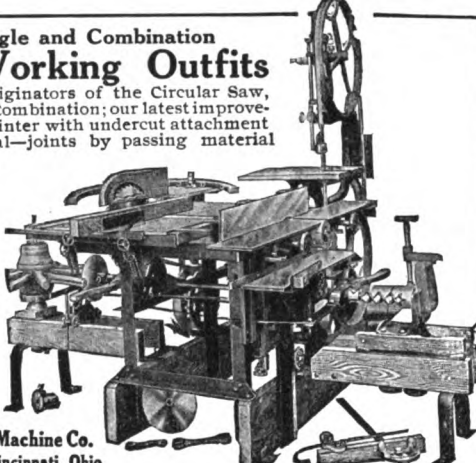

We were the originators of the Circular Saw, Band Saw, Jointer Combination; our latest improvement is the 6 in. Jointer with undercut attachment for sizing material — joints by passing material over cutter head and sizes it by passing it back under the cutter head. All machines ready for instant use.

Machines are made in large quantities which enable us to sell at lowest prices and make immediate shipment.

Write for Catalog

**Parks Ball Bearing Machine Co. 4100 Fergus St., Cincinnati, Ohio**

**Bermo Welding Plants**  
OXY-ACETYLENE  
13 years successful record.  
Guaranteed. Write for Catalog and Easy Terms.  
**\$25 to \$250**  
**Bermo Supply Co., Omaha, Neb.**

Every time you don't find what you want in "Our Journal" please tell us about it.

**American Blacksmith Co.**

**TRADE LITERATURE AND NOTES.**

**Absorbine is Made of Herbs.** — Herbs which are grown on the spacious farm owned and worked by the manufacturer. Absorbine is germicidal, antiseptic and non-poisonous. When applied to an open sore or wound it not only makes the part aseptically clean but kills the germs and causes a healthy healing from the bottom.

Use Absorbine on your blemished horse and prove its worth to your own satisfaction.

Mr. M. M. Stacy, Elm Grove, Mass., writes under date of March 6, 1916: "The Absorbine did all that you claim for it. My horse had the largest boil I think that I ever saw and now it is all gone. I would not have thought that the Absorbine would have taken it so completely away. Am glad I know so valuable a remedy and thank you very much."

Thousands of letters are received by the manufacturer of Absorbine telling of the wonderful results customers have obtained by the use of this liniment.

Get your horses sound. A blemish decreases the selling and working value of a horse. Try Absorbine—Once used always used. Write for free advice about your

case. Absorbine \$2.00 a bottle at druggists or postpaid. W. F. Young, P.D.F., 230 Temple Street, Springfield, Mass.

In designing **Torit Welding Apparatus** advertised on another page in this issue, the Evleth-Lindsey Co., St. Paul, Minn., has paid special attention to the problem of thoroughly mixing the two gases and so avoiding dangerous and bothersome flashbacks. A small mixing chamber is provided to insure a proper mixture delivered to the nozzle, and that this mixture will always be uniform.

This is only one feature of **Torit Apparatus** which is offered to American Blacksmith readers at a reasonable price—although the manufacturers assure us that only the very highest grade materials and most advanced ideas are embodied in this equipment.

If you have not taken up **Oxy-Acetylene Welding** we would suggest that you write for circular the above firm offers to send free. If you are now handling welding, this catalog will also be of interest to you—as the Evleth-Lindsay Co., handle a full line of welders' supplies, and their torches embody ideas which should be of interest to all welders.

A very valuable attachment for Ford cars is the **Safety First Headlight Bracket** advertised in this issue by the Mowers Mfg. Co., St. Cloud, Minnesota.

This bracket is easily and quickly attached to any Ford car and turns the lights with the front wheels in exactly same direction that the car turns, eliminating the danger of turning dark corners because the lights are always ahead of the wheels.

We are sure that our readers could make good profits by selling and attaching these brackets for the Ford owners in their sections. They add greatly to the appearance of the car.

We would suggest that if you are interested, you write the above firm for circulars—gladly sent on request—also regarding the agency for your section as they are looking for good agents where they are not now represented.

**Every Worker at the Forge** knows with what difficulty the art of "tempering by color" is acquired. It is, in fact, an art which requires years of training and experience before one becomes at all pro-

(Continued on Page 49)

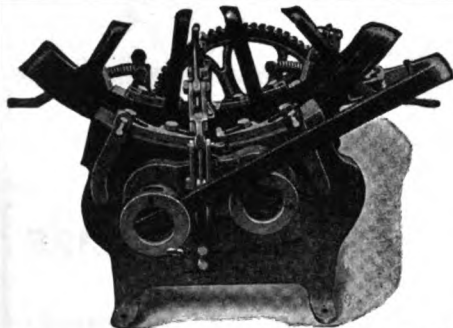

### The Brooks Cold Tire Setter

Sets tires cold on the wheel and is the pioneer edge-grip hand-power cold tire setter. Used and officially endorsed by the United States Government in the Department of War and Interior. Thousands of blacksmiths in the U. S. consider it the most profitable machine in their shop. We build both hydraulic and lever cold tire setters. The Brooks does the work quicker and better than any other cold tire setter on the market and should be in every blacksmith and carriage repairer's shop. Write for catalog and prices.

We are also manufacturers of the latest improved Oxy-Acetylene Welding machines and generators, equipped with our famous Safety Flash Back Valve. It prevents explosions.

We also build Welding Outfits to be used with cylinder gases.

Our catalog will interest you and is free for the asking.

The Brooks Machine Company, Wichita, Kansas

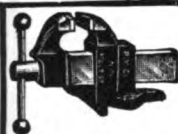

### Prentiss Patent Vises BEST MADE

Large Illustrated Catalog Free

Prentiss Vise Co., Hardware Bld., New York

"NEW EASY" 4 Sizes

### BOLT CLIPPERS

"EASY" 2 Sizes

THE GENUINE TOOL



KNOWN AND PREFERRED EVERYWHERE

H. K. PORTER

EVERETT, MASS.

U. S. A.

**Big Profits** A relatively small investment in one of our outfits will give you exceedingly large returns and at the same time gives you an equipment that is unequalled in safety, economy and efficiency. **FREE BOOK**—Our new illustrated catalog shows work actually done, gives cost of operation and other valuable data. **THE IMPERIAL BRASS MFG. CO.,** 1220 West Harrison Street. Chicago

### "Bay State" Carriage and Tire Bolt Ratchet Wrenches

Labor Savers! Money Savers!



Three Sizes Take Hex and Square Nuts

GEO. A. CUTTER, Sales Agent, Taunton, Mass.

Ask Your Dealer

### Your Ford will not turn Turtle

If Equipped with an Irreversible Worm Steering Gear

Holds your car straight ahead and steady. Ruts, bumps or holes in the road cannot turn your wheels aside. No wiggling—no jerking motion. Steers your Ford the way you want it, through mud and sand and on center-crowned and hard, bumpy roads. All high-priced autos have this style of steering gear.



No vibration, shock or strain on arms and shoulders if your Ford has this irreversible worm steering gear. You can drive all day without tiring.

Attaches to Engine. No Holes to Bore.

Inexpensive. Easy to put on a Ford. Thousands in use. Sold under binding guarantee of

Money Back if Not Satisfied

Make your Ford SAFE. If your wife or daughter drives, give her the protection and pleasure of this steering gear.

You can get it from your dealer or direct from us. Full information free. Big opportunity for local representatives. Don't wait until it's too late. Write today.

E. H. SPRAGUE MFG. CO., Dept. 9. Omaha, Neb.

### Butterfield's Screw Plates

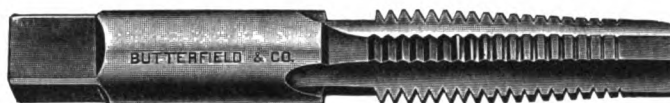

We do not claim to be the oldest manufacturers of Screw Plates. We are not sure that this is any distinction.

Our claims for the superiority of our TAPS and SCREW PLATES are based on actual performance. The rapid growth of our business, is proof positive of the excellence of our product.

Be sure you ask for BUTTERFIELDS, and take no substitute.

NEW YORK STORE 126 Chambers Street BUTTERFIELD & CO. DERBY LINE, VT., U.S.A.

### TRADE LITERATURE AND NOTES.

(Continued from Page 48)

efficient; even then there remains an element of uncertainty in results.

Yet advancement in this direction is not an impossibility, as proven by recent scientific discoveries, which have already removed the process of tempering from the realm of Art to that of an exact Science.

William Ruyle, a worker in one of the big foundries in the middle West, experimented for years trying to find a compound that would permit tempering to be carried on in a definite, sure fashion and eliminate the uncertainty and costliness of the old-time process. His discovery, appropriately named "Ruylite" after its inventor, fulfills this need to perfection, placing within easy grasp of all the ability to temper chisels, dies, punches, and all other tools requiring a high and uniform temper.

The manufacturers cover all claims for their product with a broad guarantee, providing the user carefully follows the directions which accompany each package. Further information as to the merits and uses of RUYLITE may be obtained by writing direct to the Ruylite Manufacturing Company, Hutchinson, Kansas.



ED. H. WITTE, Pres.

### My Special Model KEROSENE ENGINE

CUTS FUEL COST 65 PER CENT

Not an experiment! Thousands in use! Better and more powerful than ever! Starts as easily as a gasoline engine! Will use any fuel that can be used in a kerosene engine! You get three times as much power for the money, at present fuel prices! Latest Improvements! Your Own Terms! Cash, Deposit, Payments, or No Money Down! If you are in the market, write me today! I CAN MAKE YOU THE BEST PRICE—Sell You A BETTER Engine. Any style, 2 to 22 H-P.—Save you \$25 to \$100.

### Immediate Shipment WITTE HIGH GRADE ENGINES

are made in the largest exclusive engine factory in the world, selling direct. You can see quality in every line and curve. Look at the long solid base affording absolutely solid footing. See how cleanly-built—no cumbersome overweight of cast iron—no cylinder hanging out behind—no interior packing—vertical valves—auto ignition—no cranking—and many other special features that make WITTE Engines high-grade, better and more desirable. 90 Days' Trial will fully prove superior quality.



Write for latest Engine prices and Free Book. Or, wire your order—I will handle it—save you time and money. Ed. H. Witte,

WITTE ENGINE WORKS 1762 Oakland Ave., Kansas City, Mo. 1762 Empire Bldg., Pittsburgh, Pa.

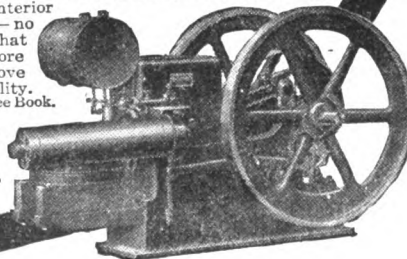



# ONCE IS ENOUGH

to break your bones, lay you up in bed for weeks, and pile up bills enough to keep you broke for months. Compared with such a costly experience you are indeed practicing true economy when you use



## Barcus Safety Horse Stocks

The great feature of Barcus stocks is the Safety Foot Clamp. Automatic in action it works positively, quickly and safely. The foot is held as secure as if it were in a vise. And there are none of those ropes, straps or buckles so bothersome in the ordinary stock.

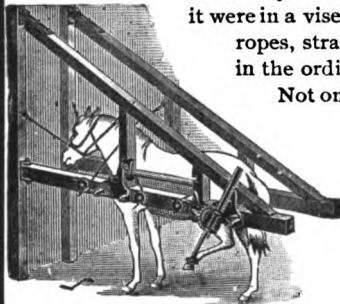

Not only do you protect yourself but you play square with your men and show a humane regard for the animals placed in your care, when you have Barcus stocks. The cost? Much less than you think—write and find out.

The Barcus Mfg. Co., Wabash, Indiana.

# NW

## Northwestern Horse Nails

Are the Best All Around FOR STRENGTH, SAFETY and QUALITY OF MATERIAL



The most perfect in form and finish. Made of the highest grade material to our own analysis. Will hold a shoe longer than any other nail made. Has a re-enforced point—making it easiest to drive and the safest to use.

Union Horse Nail Co., Chicago, Ill.



TWO BIG HELPS IN WELDING DON'T BE WITHOUT THEM



## "E-Z" Welding Compound

is the best BECAUSE it works equally good on all kinds of steel. It welds at lower heat than any other. It sticks to metal at a very low heat. It leaves no scale. Use it once and you will always want it.

## Crescent Welding Compound

makes smoother welds than any other. It is fine for plow work or where parts are fastened together before welding, or for making split welds, finishing heats, or for welding under dies, etc., etc. It insures smooth finish and perfect welds on Toe Calks.

"Money back" from any jobber if "E-Z" or Crescent does not give perfect results.

We Will Send Samples Free.

Made only by

Anti-Borax Compound Co.

FORT WAYNE, IND.

## THE ROCHESTER HARD HITTING HELVE HAMMER

Made in many sizes to fit the exact requirements of your work. Write for illustrated booklet.

Here's a hammer that will make money for you, Mr. Smith, day in and day out. It will do the work of any other hammer, and then some. Made in six sizes—one of them is the hammer you need.

The ROCHESTER HELVE HAMMER is strongly made of first class material throughout. First grade hickory helve; exceptionally heavy anvil, giving greatest resistance to blow struck; steel base; long bearings for helve pivot. Fine for welding tires, work which cannot be done under most upright hammers. Dies can be furnished either lengthways or crossways of helve without additional cost, if specified with order.

Send for our illustrated catalogue free.

Makers of the Celebrated WEST HYDRAULIC TIRE SETTERS

THE WEST TIRE SETTER CO.

ROCHESTER, N. Y.

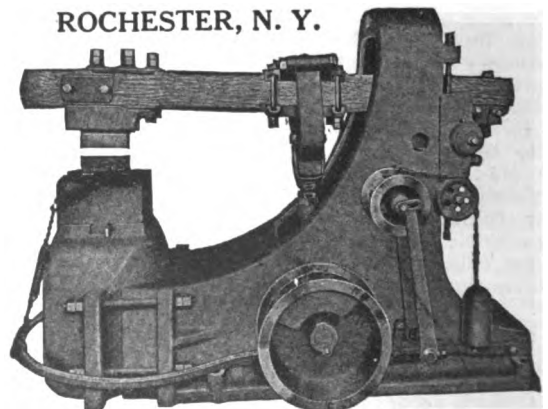

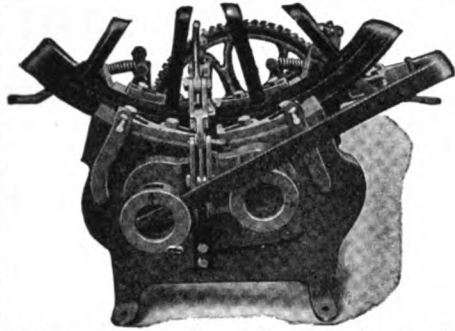

### The Brooks Cold Tire Setter

Sets tires cold on the wheel and is the pioneer edge-grip hand-power cold tire setter. Used and officially endorsed by the United States Government in the Department of War and Interior. Thousands of blacksmiths in the U. S. consider it the most profitable machine in their shop. We build both hydraulic and lever cold tire setters. The Brooks does the work quicker and better than any other cold tire setter on the market and should be in every blacksmith and carriage repairer's shop. Write for catalog and prices.

We are also manufacturers of the latest improved Oxy-Acetylene Welding machines and generators, equipped with our famous Safety Flash Back Valve. It prevents explosions.

We also build Welding Outfits to be used with cylinder gases.

Our catalog will interest you and is free for the asking.

The Brooks Machine Company, Wichita, Kansas

#### TRADE LITERATURE AND NOTES.

#### The Horse—His Breeding, Care and Treatment in Health and Disease, by Henry C. Merwin.

All lovers of the horse will find much of great interest and practical value in this new book written by the President of the Boston Work-Horse Relief Association. It represents the work of a lifetime, in a sense, inasmuch as Mr. Merwin has been accumulating the wealth of ideas and facts expressed therein since childhood.

The subject matter contained within its 275 pages treats of every phase of horse life—breeding, care, feeding, driving, working, shoeing, the treatment of horse diseases and injuries and many other subjects of vital import to everyone who has anything at all to do with the horse. It is written in a clear, understandable manner, free from technical and scientific wording and is withal a work we can recommend heartily to the practical blacksmith.

Readers may secure copies and price by writing to the American Blacksmith Book Department.

#### Weaver 20-Ton Press

The accompanying illustration represents a very unique construction in the line of Screw Presses and to the experienced engineer the many advantages of this construction will be readily apparent.

One very special feature is its enormous leverage. At the end of a 30-inch lever the power gained is as 1500 to 1. If necessary however, this leverage can be doubled making a leverage of approximately 3,000 to 1. This is accomplished by shifting the



plunger arm into the center socket on the fulcrum block to which the lever is attached. With this leverage one man can produce a pressure of over 30 tons with very little effort.

Another feature which distinguishes this Press from other types is its strong, (Continued on Page 46)



ED. H. WITTE

# I Can Make You The Best PRICE

## On a Kerosene Engine

Sell You a Better Engine—Save You \$25 to \$100

Not an experiment! Hundreds in Use! Better and more powerful than ever! Starts as easily as a gasoline engine! Will use any fuel that can be used in a Kerosene engine! You get three times as much power for the money at present fuel prices! Your own terms! Cash, Deposit, Payments, or No Money Down! If you are in the market, write me today! I CAN MAKE YOU THE BEST PRICE—Sell You a BETTER Engine—Ship At Once! Any Style—Stationary or Portable.

## WITTE ENGINES

Kerosene and Gasoline—2 to 22 H-P.

are made in the largest exclusive direct selling engine factory in the world. I make nothing but engines. Over 30 years success proves quality—immediate shipment proves superior factory equipment and business methods—just as my engines are superior. You can see the high quality in every line and curve. Look at the long solid base affording absolutely solid footing. See how cleanly-built—no cumbersome over-weight of metal—no cylinder hanging out behind—no interior packing—vertical valves and many other special features that make WITTE Engines high-grade, better, and more desirable. 90-Day Trial will fully convince you of superior quality. Write for latest price and free book, or come to factory and see them—You are welcome. Ed. H. Witte,

# FREE



### WITTE ENGINE WORKS

1769 Oakland Ave., Kansas City, Mo.

1769 Empire Bldg., Pittsburgh, Pa.

Write for this Beautiful 4 Color Illustrated FREE BOOK Today! Yours for a Post Card—by Return Mail.

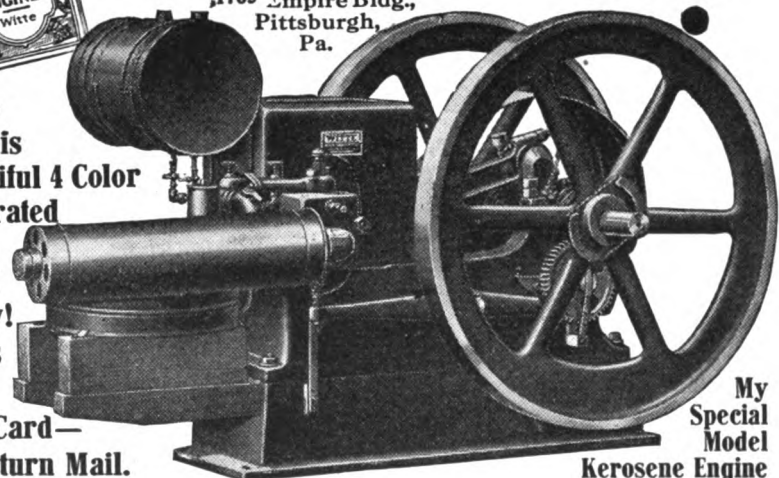

My Special Model Kerosene Engine

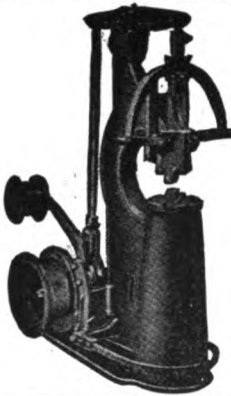

### BETTER THAN THREE SLEDGE HAMMERS Little Iowa Power Hammer No. 3

No three men can hammer out as much work as this easily operated, powerful hammer. And it has an even stroke, and accuracy impossible to attain by human efforts.  
Powerful 35-pound hammer head with a total weight of 850 pounds and a compact base, 22 inches by 38 inches. Guaranteed to satisfy. If it fails, send it back at our expense. We'll refund your money. Price, \$75.00. Send for descriptive booklet.  
Every United States jobber represents us. Canadian Agent: D. Ackland & Son, Ltd., Winnipeg, Can. Agent for Montevideo-Uruguay, Caso en Pando: Ambrosia Bertolotti.

**MODERN SALES CO.**  
Hampton, Iowa - - U. S. A

## Bermo Welding Plants

OXY-ACETYLENE

13 years successful record.

Guaranteed. Write for Catalog and Easy Terms.

\$25 to \$250

**Bermo Supply Co., Omaha, Neb.**

Every time you don't find what you want in "Our Journal" please tell us about it.

American Blacksmith Co.

### TRADE LITERATURE AND NOTES.

(Continued from Page 45)

one-piece frame construction. It will be noticed that the frame of the Press is composed of one solid, heavy piece with no bolted connections or joints to weaken it. At the top of the frame there is a rigid truss brace which effectually prevents the Press from buckling even under the most severe pressure.

The unusual width of 32 inches between the uprights of the frame enables large, bulky work to be easily handled. This is capable of adjustment to allow a space of 48 inches in height and 32 inches in width.

Full information may be obtained from the manufacturers: The Weaver Mfg Co., Springfield, Ill.

**LITTLE IS KNOWN BY AVERAGE MOTORIST OR DEALER ABOUT THE MAKING OF SPRINGS. ENGINEER OF TUTHILL SPRING CO. GIVES INTERESTING INTERVIEW ON THIS SUBJECT.**

"The actual manufacture of automobile springs is a very interesting and intricate problem," says Mr. H. T. Moore, of the Tuthill Spring Co., Chicago. "To most people a spring is a spring, and that's the end of it. It is really a product of science—and often causes the designing engineer no end of worry.

"Spring design is a compromise between strength and weakness. Yes and more than that—for such disturbing factors as sideway stresses, torque thrusts and driving strains must be carefully considered.

"When the engineer gets the weights the spring is to carry, he must contrive a spring so strong that it will not break, or allow the car frame or body to bump on the axles. Yet it must not be so strong

See that Arch



that it will be stiff and hard riding even when the car has no passengers in it. Furthermore, it must be so constructed that it will take the driving strain and torque thrusts without buckling or bending out of its proper shape. It must also be able to withstand all the stresses set up by side sway and abnormal deflections due to bumps and ruts in the road. These are some of the considerations that claim attention."

In the Tuthill spring all these factors The speed control is all within the motor



**Prentiss Patent Vises**  
BEST MADE  
Large Illustrated Catalog Free  
Prentiss Vise Co., Hardware Bld., New York

**Big Profits** A relatively small investment in one of our outfits will give you exceedingly large returns and at the same time gives you an equipment that is unequalled in safety, economy and efficiency.  
FREE BOOK—Our new illustrated catalog shows work actually done, gives cost of operation and other valuable data.  
**THE IMPERIAL BRASS MFG. CO.,**  
1220 West Harrison Street. Chicago

"NEW EASY" 4 Sizes **BOLT CLIPPERS** "EASY" 2 Sizes  
THE GENUINE TOOL  
H. K. PORTER  
EVERETT, MASS.  
U. S. A.  
KNOWN AND PREFERRED EVERYWHERE



"Bay State" Carriage and Tire Bolt Ratchet Wrenches  
Labor Savers!  
Money Savers!  
GEO. A. CUTTER, Sales Agent, Taunton, Mass.  
Three Sizes Take Hex and Square Nuts  
Ask Your Dealer

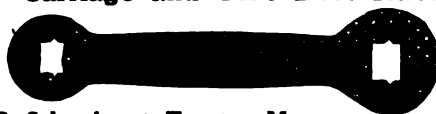

## Butterfield's Screw Plates

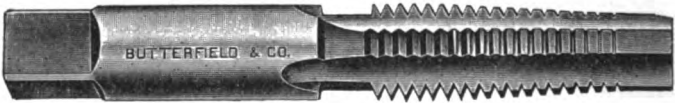

We do not claim to be the oldest manufacturers of Screw Plates. We are not sure that this is any distinction.  
Our claims for the superiority of our TAPS and SCREW PLATES are based on actual performance. The rapid growth of our business, is proof positive of the excellence of our product.  
Be sure you ask for BUTTERFIELDS, and take no substitute.  
NEW YORK STORE 126 Chambers Street **BUTTERFIELD & CO.** DERBY LINE, VT., U.S.A.

are scientifically taken care of, and the spring is thoroughly tested before it is placed on the market. Accordingly, the broad claims and specific guarantees against breakage made by the Tuthill Company should have considerable weight with prospective purchasers of automobile and carriage springs.

The R. P. Warner Electric Company of Kalamazoo, Mich., has placed on the market a variable speed forge blower, called the Kazoo, which is unique in many ways inasmuch as it operates on the ordinary lamp socket of 110 volts, alternating current.

A noteworthy feature, wherein the Kazoo differs from other blowers is in the  
(Continued on Page 48)

### BALL AND ROLLER BEARINGS.



**THE GWILLIAM COMPANY**  
The New Departure Service Station  
New York: 2 Columbus Circle (58th St. at Broadway)  
Philadelphia: 1314 Arch Street

## BEFORE BUYING

A New Anvil, write us. It will pay you  
**THE COLUMBUS ANVIL & FORGING CO.**  
COLUMBUS, OHIO



**CURRENT HEAVY HARDWARE PRICES.**

The following quotations are the lowest prices generally prevailing throughout July, 1917. They are subject to change without notice, and higher prices are charged according to quality, specifications and other conditions. Material which is hard to secure, or which is only to be found in stock in one or two houses, generally commands a premium over current prices.

Since the last issue there has been no change in iron and steel bars, bolts, nuts, lag screws and bolts ends. Correspondents advise that new prices on Neverslip, Giant Grip and other branded goods including shoes, calks, etc., have been put into effect. Manufacturers of horse shoes have made another advance of 50 cents per keg which has forced the jobbers to make a similar advance in their quotations.

**Horse Shoes—**

All Iron Shoes	.....	\$7.00-\$7.20
Steel Shoes	.....	\$5.00-6.25
No. 0 and No. 1, 25 cents extra.	15 cents per keg additional charged for packing more than one size in a keg.	
Mule Shoes	.....	
X. L. Steel Shoes	.....	
Countersunk Steel Shoes	.....	\$6.55
Tip Shoes	.....	
Goodenough, heavy	.....	
Goodenough, sharp	.....	
Toe Weight, pr.	.....	.25
Side Weight, pr.	.....	.25
E. E. Light Steel	.....	6.80
Steel Driving	.....	
O. O. Mule Shoes, extra	.....	

Anvils ..... \$17 1/2 & \$18 1/2

**Merchant Bar Iron—**

\$4.75 rates, full extras.

**Steel Bars—**

\$4.75 rates, full extras.

**Toe Calks—**

Per Box

Blunt	.....	\$2.00
Sharp	.....	2.25

**Screw Calks—**

	5-16	%	7-16	1/4	5/8
Blissard M	\$20.00	\$20.00	\$22.00	\$22.00	\$24.00
Sure Grip M	20.00	20.00	22.00	22.00	24.00
Bl. Diam. M	20.00	20.00	22.00	24.00	24.00
Red Tip M	22.00	22.00	24.00	24.00	26.00
Rowe, Jr. M	20.00	20.00	22.00	22.00	24.00
King Pt. M	22.00	22.00	24.00	24.00	26.00

**Plow Goods—**

Soft Solid Center Cast Crucible

Blank Shares	.....	\$28 1/2	\$17 1/2	\$18
Landside Plates	.....	.23	.16%	.18
Lister Lays—Triangle	.....	.29	.20	.22
Lister Lays—V-Pattern	.....	.30	.21	.23
Lister	.....	.32	.24	.25
Mould Boards	.....	.26	.18 1/2	.19 1/2
Cult. Shov. Blanks	.....	2.95	2.10	2.40
(5x5 1/2 x 10 1/2)				

**Hickory Lumber—Per Foot—**

1" to 2 1/2"	.....	\$ .11
4"	.....	.12 1/2

**Ash and Oak Lumber—Per Foot—**

1 —1 1/4	.....	\$ .10	2 1/2—3	.....	\$.12
1 1/2—2	.....	.10 1/2	3 1/2—4	.....	.12

**Yellow Poplar Lumber, Per M. Feet—**

1/2-8" & 9"	.....	\$ 80.00
1/2-24" & 27"	.....	110.00
1/2-34" & up	.....	185.00
3/4-6" to 12"	.....	82.00
3/4-24" to 28"	.....	114.00
1 1/2-18" to 23"	.....	95.00

**Hickory Wagon Axles Select Rough**

2 1/2 x 3 1/2 x 6' and up	.....	\$150.00
4 1/2 x 5 1/2 x 6' and up	.....	200.00

**Finished Hickory Axles—**

For 2 1/2 and 2 3/4 Skeins	.....	\$ .95
For 3 Skeins	.....	1.38
For 3 1/4 Skeins	.....	1.48
For 3 1/2 Skeins	.....	1.63
For 4 1/4 Skeins	.....	1.90
For 4 Skeins	.....	2.10

**Rough Oak Bolsters—**

3 x 4	.....	\$1.25
4 x 5	.....	1.60

**Finished Bolsters—**

2 1/4 and 3 1/4	.....	\$.70
3 1/4	.....	.92
3 3/4	.....	1.10
Mortising extra	.....	.10

**Rough Oak Wagon Tongues—**

4 x 4, 2 x 4, 12 and smaller	.....	\$1.50
------------------------------	-------	--------

**Finished Oak Wagon Tongues—**

3 1/2 and smaller	.....	\$1.50
3 3/4	.....	1.60
4	.....	1.70

**Oak Bent Wagon Hounds Flat**

1 1/2 x 2 3/4	.....	\$1.35
2 x 3	.....	1.35
2 1/4 x 3 1/4	.....	1.85
2 1/2 x 3 1/2	.....	2.00

**Two-Inch Sawed Hounds—**

Per Pair

Tongues	.....	38c
Front	.....	44c
Hind	.....	55c

**Round Edge Steel & Round Edge Iron Tire—**

1 1/2 x 1/2 and larger	.....	\$4.75
R. E. Iron, all sizes	.....	4.75

**Special Tired Wheels—"F" Grade—3 or 4 piece Rim—**

0 3/4 x 1/4	.....	\$ 9.00	9 1 1/2 x 1/4	.....	\$12.15
1 1/2 x 1/4	.....	11.50	9 1 1/2 x 5-16	.....	15.75
8 1 x 1/4	.....	12.00	13 1 1/4 x 5-16	.....	19.00
8 1 x 5-16	.....	10.90	13 1 1/4 x 3/8	.....	19.75

**Plain End Oak Hubs—**

**Cupped Oak Hubs—**

10 x 14	.....	\$3.60	7 x 8 x 9	.....	\$1.40
11 x 14	.....	4.40	7 x 9 x 10	.....	1.65
11 x 15	.....	4.95	8 x 9 x 10	.....	1.70
11 x 16	.....	5.60	8 x 10 x 11	.....	1.95
12 x 16	.....	6.80	9 x 10 x 11	.....	2.15
12 x 17	.....	6.90	9 x 11 x 12	.....	2.20
13 x 18	.....	7.70	10 x 12 x 18	.....	3.80
			11 x 18 x 14	.....	4.60
			12 x 14 x 15	.....	5.60

**Rough Sawed Felices—**

1 1/2 x 2	.....	\$1.80	2 x 2 1/2	.....	\$3.00
1 1/2 x 2 1/4	.....	1.90	2 1/2 x 2	.....	3.85
1 1/2 x 2 1/2	.....	2.00	8 x 8	.....	5.75
8 x 8 1/2	.....				\$6.80

**Ironed Poles, White, XXX—**

1 1/2 x 2 1/2" No. 2	.....	\$7.15
2 x 2 1/2" No. 3	.....	7.15

**Ironed Shaft, White, XXX—**

1 1/2 x 2" and smaller	.....	\$3.25
1 1/2 x 2"	.....	2.88
1 1/2 x 2 1/4"	.....	4.61

**Farm Wagon Bows—**

Round Top, 1/2 x 2"	.....	\$ .60
Flat Top, 1/2 x 2"	.....	.75
Round Top, 3/4 x 2 1/2"	.....	1.35

**Standard Size Piano Bodies—**

Each	.....	\$6.00
------	-------	--------

**Plow Beams—**

1 Horse	.....	\$.60
2 Horse	.....	.85
3 Horse	.....	1.80

**Spokes and Rims, Hickory, rounded & bored—**

Oak and Hickory Spokes, 40-5% on Weiss & Lesh List.	.....	
Finished Rims—XX—1/4"	.....	\$1.80
Finished Rims—XX—1"	.....	2.15

**Oval Plow Dbl'trees— Flat Plow Dbl'trees—**

2 1/2 x 80"	.....	\$1.10	1 1/2 x 3 1/2 x 42"	.....	\$3.00
-------------	-------	--------	---------------------	-------	--------

**Wagon Evener Woods—**

2 x 4 and 2 x 4 1/2—Keller & Tamm's List—Discount	.....	15%
Larger	.....	12 1/2%

**Buggy Evener Woods—All Grades—**

Keller & Tamm's List—Discount	.....	12 1/2%
-------------------------------	-------	---------

**Buggy Whiffetree Woods—**

Mixed Second Growth and Second Growth—Keller & Tamm's List—Discount	.....	12 1/2%
---	-------	---------

**Buggy Neckyoke Woods—All Grades—**

Discount	.....	6 1/2%
----------	-------	--------

**"DUPLEX" BOLT DIE STOCK SETS**

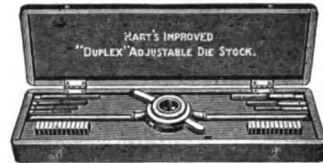

They contain dies that adjust without a wrench and require no reversing after cutting.

THE HART MFG. CO.

2325 E. 20th St. Cleveland, Ohio

**Horse Shoe Bar Iron**

MADE BY

**The Milton Mfg. Company**

MILTON, PENN'A

Is of Superior Strength and Quality. We can prove it. Write us.



**Best Gasoline Brazing Forge IN THE WORLD**

Thousands sold in last ten years. Four sizes. Send for catalog.

The National Rubber & Specialties Co.

4433-39 Chickering Ave., Winton Place, Cincinnati, Ohio.



**Simonsen Kold Cutter No. 1** is the handiest tool you could place on your bench. Made entirely of steel yet low in price. Will cut cold 1/2 x 2 or 1/2 x 6 in. mild steel. Write for our circular K and learn all about this bench shear.

**SIMONSEN IRON WORKS.** Sioux Rapids, Iowa, U. S. A.

**"GEARS AND WAGONS"**

**Selle Gears**

A quarter of a century of success has placed "Selle Gears" and Wagons in the hands of the largest wagon users in the world. Express and Transfer Companies, Department Stores, Fire Departments, etc.; specify "Selle Gears" and will take no other after once tried.

230 page catalog free

THE AKRONSELLE CO. Akron, Ohio



# Ruylite

TRADE MARK

Here is something that you need every day. How often do you try to temper some tool and the first time you use it, it will bend, break or batter and maybe go to pieces, and then lose your temper, say that the steel is no good, the day is too dark, or lay it to some unknown cause.

Why not modernize your way of tempering?

RUYLITE will accomplish these things.

RUYLITE is especially adapted to chisels, punches, dies, etc., etc.

RUYLITE is put up in one pound cartons selling at \$3.00 per pound.

Any one mechanically inclined can get RUYLITE results by following our directions, and be almost as proficient as an expert tool dresser.

One pound will temper many dollars worth of tools. We guarantee RUYLITE to do all we claim or money refunded. Mailed to any address at above named price.

**RUYLITE MFG. CO., Hutchinson, Kansas**

## The AMERICAN Represents the Standard in Oxy-Acetylene WELDING & CUTTING Apparatus

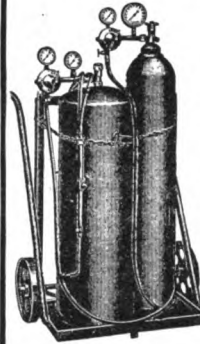

Model O. W.

Our Model O. W. Outfit is designed for heavy work and will withstand the constant service that the blacksmith and boiler shop demand.

An injector type torch recognized as the most efficient and due to the exactness of construction cannot be made to back-fire. Large welding jobs that are entirely out of range of the ordinary welding outfit are successfully and easily accomplished with the AMERICAN positively non-back-firing torch.

Write for descriptive Booklet.

**AMERICAN WELDING CO., Inc.**  
2724 MICHIGAN AVE. CHICAGO, ILL.

### TRADE LITERATURE AND NOTES.

(Continued from Page 46)

absence of an outside controlling device. itself, and any draft may be had by using the draft handle. Thus a common source of annoyance is eliminated—that of having to stop work on account of motor trouble arising from dirt and soot.

Full information concerning the "Kazoo" may be obtained by dropping a line to the above address.

For making quick auto spring repairs, the blacksmith will find the Harvey oil-tempered, ready-to-use repair plates a great convenience.

They are made in such a variety of sizes and forms that it becomes a simple matter to select just the one needed, drill center holes and quickly re-assemble. They are capable of shortening and bend-

ing easily to make a perfect fit in every case.

Auto repair smiths may secure valuable data on spring repairs by writing to the manufacturers: The Harvey Spring and Forging Co., Racine, Wis.

### AN IMPROVED WELDING TORCH.

The Bishop-Babcock-Becker Company has marketed a new welding torch as illustrated below. This torch has a single tube and it is therefore possible to do the



lightest and heaviest welding by simply changing the tubes.

The manufacturers state that when the proper gas pressure is obtained it is prac-

tically impossible for this new torch to back-fire, regardless of the size of tip used. This feature will be appreciated by every user, as it not only saves a great deal of time but eliminates considerable trouble.

Attention is called to the fact that while this welding torch is durably constructed it is light and easy to handle, being designed to fit the hand. It is said that the torch is simple to operate and skilled labor is not required. The illustration shows that the valves are conveniently placed below the handle, and a proper mixture is secured without difficulty. The manufacturers, whose general offices and factories are located at Cleveland, Ohio, will be glad to give further particulars, and will send a complete catalog describing their oxy-acetylene welding and cutting apparatus upon request.

# Only a Few Left---

There are still unsold a few of the books advertised last month. Those left go to first comers, so if you want to secure one or more valuable books at bargain prices, better act at once.

The Modern Gas Tractor, Its Construction, Operation, Application and Repair, by Victor W. Page, 1913 Edition. Regular Price, \$2.00; Sales Price, \$1.00.

The 20th Century Toolsmith and Steelworker, by H. Holford, 1907 Edition. Regular Price, \$1.50; Sales Price, \$1.00.

Brook's Automobile Hand Books. Regular Price, \$2.00; Sales Price, \$1.25.

Gas, Gasoline and Oil Engines, by Gardner D. Hiscox, 1906 Edition. Regular Price, \$2.50; Sales Price, \$1.50.

Dyke's Automobile & Gasoline Engine Encyclopedia, by A. L. Dyke, 1913 Edition. Regular Price, \$3.00; Sales Price, \$1.50.

Automobile Troubles and How to Remedy Them. Regular Price, \$1.00; Sales Price, \$0.50.

Oxy-Acetylene Welding and Cutting. Regular Price, \$1.00; Sales Price, \$0.75.

Prof. Rich's New Artistic Horseshoeing. Regular Price, \$2.00; Sales Price, \$1.25.

The Modern Gasoline Automobile, Its Construction, Operation, Maintenance and Repair, by Victor W. Page, 1913 Edition. Regular Price, \$2.50; Sales Price, \$1.50.

These books are slightly 'shelf-worn' but every book is complete and in good condition. These special prices include packing and postage and apply *only* to the few books now in stock. We cannot furnish copies of the above books after the present limited stock is sold. If you want one or more, send in your order and remittance NOW to insure getting the book you want. Address

BOOK DEPARTMENT

**American Blacksmith Company, Box 974, Buffalo, N. Y.**



**CURRENT HEAVY HARDWARE PRICES.**

The following quotations are the lowest prices generally prevailing throughout August, 1917. They are subject to change without notice, and higher prices are charged according to quality, specifications and other conditions. Material which is hard to secure, or which is only to be found in stock in one or two houses, generally commands a premium over current prices.

Since the last issue there has been no change in iron and steel bars, bolts, nuts, lag screws and bolt ends. Correspondents advise however, advances on blue annealed and galvanized sheets, also black sheets. Nuts in keg lots are being quoted at a little lower figure.

**Horse Shoes—**

All Iron Shoes	\$7.00-\$7.20
Steel Shoes	\$5.00-6.25
No. 0 and No. 1, 25 cents extra.	15 cents per keg additional charged for packing more than one size in a keg.
Mule Shoes	
X. L. Steel Shoes	
Countersunk Steel Shoes	\$6.55
Tip Shoes	
Goodenough, heavy	
Goodenough, sharp	
Toe Weight, pr.	.25
Side Weight, pr.	.25
E. E. Light Steel	6.80
Steel Driving	
O. O. Mule Shoes, extra	

Anvils .....\$17 1/2 & \$18 1/2

**Merchant Bar Iron—**

\$4.75 rates, full extras.

**Steel Bars—**

\$4.75 rates, full extras.

**Toe Calks—**

Per Box

Blunt	\$2.10
Sharp	2.85

**Screw Calks—**

5-16	3/8	7-16	1/2	3/4	
Blissard M	\$20.00	\$20.00	\$22.00	\$22.00	\$24.00
Sure Grip M	20.00	20.00	22.00	22.00	24.00
Bl. Diam. M	20.00	20.00	22.00	24.00	24.00
Red Tip M	22.00	22.00	24.00	24.00	26.00
Rowe, Jr. M	20.00	20.00	22.00	22.00	24.00
Ring Pt. M	22.00	22.00	24.00	24.00	26.00

**Plow Goods—**

Soft Cast Crucible

Blank Shares	\$23 1/2	\$17 1/2	\$18
Landside Plates	.28	.16 1/2	.18
Lister Lays—Triangle	.29	.30	.32
Lister Lays—V-Pattern	.80	.21	.23
Lister	.32	.24	.23
Mould Boards	.26	.18 1/2	.19 1/2
Cult. Shov Blanks	2.95	2.10	2.40
(5x5 1/2 x 10 1/2)			

**Hickory Lumber—Per Foot—**

1" to 2 1/2"	\$ .11
4"	.12 1/2

**Ash and Oak Lumber—Per Foot—**

1 — 1 1/2	\$.10	2 1/2 — 3	\$.12
1 1/2 — 2	.10 1/2	3 1/2 — 4	.13

**Yellow Poplar Lumber, Per M. Feet—**

1/2-8" & 9"	\$ 80.00
1/2-24" & 27"	110.00
1/2-34" & up	185.00
3/4-6" to 12"	82.00
3/4-24" to 28"	114.00
1 1/2-18" to 23"	95.00

**Hickory Wagon Axles Select Rough**

2 1/2 x 3 1/2 x 6' and up	\$150.00
4 1/2 x 5 1/2 x 6' and up	200.00

**Finished Hickory Axles—**

For 2 1/2 & 2 3/4 Chgo & Mil. Skeins	\$1.05
For 3 Skeins	1.80
For 3 1/2 "	1.87
For 3 3/4 "	1.80
For 3 1/2 "	2.10
For 4 "	2.80

**Rough Oak Bolsters—**

3 x 4	\$1.25
4 x 5	1.60

**Finished Bolsters—**

2 1/2 and 3 1/2	\$.70
3 1/2	.92
3 3/4	1.10
Mortising extra	.10

**Rough Oak Wagon Tongues—**

4 x 4, 2 x 4, 12 and smaller	\$1.50
------------------------------	--------

**Finished Oak Wagon Tongues—**

3 1/2 and smaller	\$1.50
3 3/4	1.60
4	1.70

**Oak Bent Wagon Hounds Flat**

1 1/2 x 2 1/4	\$1.35
2 x 3	1.85
2 1/4 x 3 1/4	1.85
2 1/2 x 3 1/2	2.00

**Two-Inch Sawed Hounds—**

Per Pair

Tongues	85c
Front	45c
Hind	55c

**Round Edge Steel & Round Edge Iron Tire—**

1 1/2 x 1/2 and larger	\$4.75
R. E. Iron, all sizes	4.75

**Special Tired Wheels—"P" Grade—3 or 4 piece Rim—**

0 3/4 x 1 1/4	\$ 9.00	9 1 1/2 x 1 1/4	\$12.15
1 1/2 x 1 1/4	11.50	9 1 1/2 x 5-16	15.75
8 1 x 1 1/4	12.00	18 1 1/4 x 5-16	19.00
8 1 x 5-16	10.90	18 1 1/4 x 3/8	19.75

**Plain End Oak Hubs—**

**Cupped Oak Hubs—**

10 x 14	\$3.60	7 x 8 x 9	\$1.40
11 x 14	4.40	7 x 9 x 10	1.65
11 x 15	4.95	8 x 9 x 10	1.70
11 x 16	5.60	8 x 10 x 11	1.95
12 x 16	6.80	9 x 10 x 11	2.15
12 x 17	6.90	9 x 11 x 12	2.20
13 x 18	7.70	10 x 12 x 13	3.80
		11 x 13 x 14	4.60
		12 x 14 x 15	5.60

**Rough Sawed Fellos—**

1 1/2 x 2	\$1.80	2 x 2 1/2	\$3.00
1 3/4 x 2 1/2	1.90	2 1/2 x 2	3.85
1 3/4 x 2 1/2	2.00	3 x 2 1/2	5.75
3 x 3 1/2	\$6.80		

**Ironed Poles, White, XXX—**

1 1/2 x 2 1/2" No. 2	\$7.15
2 x 2 1/2" No. 3	7.15

**Ironed Shaft, White, XXX—**

1 1/2 x 2" and smaller	\$3.25
1 1/2 x 2"	2.88
1 1/2 x 2 1/2"	4.61

**Farm Wagon Bows—**

Round Top, 1/2 x 2"	\$ .60
Flat Top, 1/2 x 2"	.75
Round Top, 1/2 x 2 1/2"	1.85

**Standard Size Piano Bodies—**

Each	\$6.00
------	--------

**Plow Beams—**

1 Horse	\$ .60
2 Horse	.85
3 Horse	1.80

**Spokes and Rims, Hickory, rounded & bored—**

Oak and Hickory Spokes, 40-5% on Weiss & Lesh List.	
Finished Rims—XX—1/2"	\$1.80
Finished Rims—XX—1"	2.15

**Oval Plow Db'l'trees— Flat Plow Db'l'trees—**

2 1/4 x 80"	\$1.10	1 1/2 x 8 1/2 x 42"	\$3.00
-------------	--------	---------------------	--------

**Wagon Evener Woods—**

2 x 4 and 2 x 4 1/2—Keller & Tamm's List—	
Discount	.15%
Larger	12 1/2%

**Buggy Evener Woods—All Grades—**

Keller & Tamm's List—Discount	12 1/2%
-------------------------------	---------

**Buggy Whiffletree Woods—**

Mixed Second Growth and Second Growth—	
Keller & Tamm's List—Discount	12 1/2%

**Buggy Neckyoke Woods—All Grades—**

Discount	6 1/2%
----------	--------

**"DUPLEX" BOLT DIE STOCK SETS**

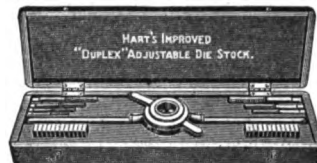

They contain dies that adjust without a wrench and require no reversing after cutting.

THE HART MFG. CO.

2325 E. 20th St. Cleveland, Ohio

**Horse Shoe Bar Iron**

MADE BY

**The Milton Mfg. Company**

**MILTON, PENNA**

Is of Superior Strength and Quality. We can prove it. Write us.



**Best Gasoline Brazing Forge**  
IN THE WORLD

Thousands sold in last ten years. Four sizes. Send for catalog.

The National Rubber & Specialties Co.

4433-39 Chickering Ave., Winton Place, Cincinnati, Ohio.



**Simonsen Kold Cutter No. 1** is the handiest tool you could place on your bench. Made entirely of steel yet low in price. Will cut cold 1/2 x 2 or 1/2 x 6 in. mild steel. Write for our circular K and learn all about this bench shear.

**SIMONSEN IRON WORKS.**  
Sioux Rapids, Iowa, U. S. A.

**"GEARS AND WAGONS"**

**Selle Gears**

A quarter of a century of success has placed "Selle Gears" and Wagons in the hands of the largest wagon users in the world. Express and Transfer Companies, Department Stores, Fire Departments, etc.; specify "Selle Gears" and will take no other after once tried.

230 page catalog free

**THE AKRONSELLE CO.** Akron, Ohio





### The AMERICAN Represents the Standard in Oxy-Acetylene *WELDING & CUTTING* Apparatus



Model O. W.

Our Model O. W. Outfit is designed for heavy work and will withstand the constant service that the blacksmith and boiler shop demand.

An injector type torch recognized as the most efficient and due to the exactness of construction cannot be made to back-fire. Large welding jobs that are entirely out of range of the ordinary welding outfit are successfully and easily accomplished with the AMERICAN positively non-back-firing torch.

Write for descriptive Booklet.

AMERICAN WELDING CO., Inc.  
2724 MICHIGAN AVE. CHICAGO, ILL.

### THERE COMES A TIME IN THE AFFAIRS OF ANVILS



When they simply cease to be useful. Nothing marks the old, unprogressive shop as quickly as a battered and scarred anvil on a rickety base. Put in a new anvil and let your customers know you are keeping your shop up-to-date.

#### ARM AND HAMMER WROUGHT IRON ANVILS

have been the desire of experienced Smiths for years because they stand up under the hardest work, expect to be roughly treated, and are made of the right stuff to last long after the ordinary anvil is out of business. Make the acquaintance of an Arm and Hammer Anvil without delay—write and let us give you the details.

THE COLUMBUS ANVIL & FORGING CO.  
Columbus, Ohio.

### If you have metal to be Cut and Punched and you're content to put off buying a Punch and Shear Your Feeling of Content is Costing You Dearly!

It does your work 6 times faster.

Earns many times more profit.

Does the same work in 10 minutes that would require 60 minutes without one.

The sooner you get one, the more it will make for you.

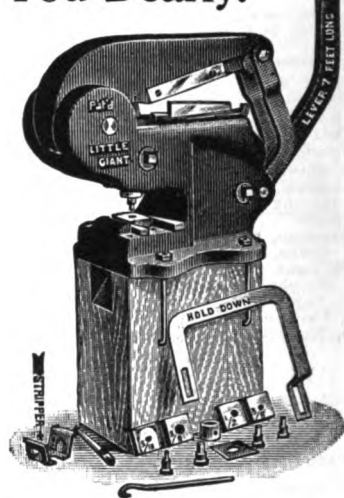

You are losing by not using a **LITTLE GIANT PUNCH and SHEAR**  
Write for Catalogue, or better still, order one from your Jobber.

**Little Giant Punch & Shear Co.,**  
210 S. Market St. SPARTA, ILL.

#### TRADE LITERATURE AND NOTES

##### A New Treatise in Oxy-Acetylene Welding

The latest book on welding by the oxy-acetylene process is unique, inasmuch as the author has written it with the sole purpose in mind of helping his fellow craftsmen to a better understanding of this subject, and not primarily for the profits to be gained from the sale of the book.

It is called: "Oxy-Acetylene Welding and Cutting" and is written by P. F. Willis. He is an authority on the subject, and his knowledge of this comparatively new process has come about through ten years of experience, in which he met with many failures and discouragements. The book is therefore practical in every respect.

The author can testify that "there is no royal road to learning," and yet in offering this treatise he is prompted by the belief that the man who ventures ahead of his fellows may thereby smooth out many of the rough spots for those who follow.

The book is sold at a price which precludes the possibility of profit. The purchaser pays only for the printing and the paper—the subject matter is gratis.

Copies may be obtained through the Book Department of THE AMERICAN BLACKSMITH; price fifty cents.

An ant with a load always pulls it even tho' she has to walk backwards to do so. This is because pushing tends to press the load into the ground, thus increasing the friction. Pulling tends to lift a load, thereby diminishing friction. It takes much less power to pull a load than to push it.

Many old pleasure cars are now being used as tractors to haul wagons which have been transformed into semi-trailers by the removal of the front wheels.

In order to draw a load safely and efficiently, the automobile is connected with the wagon by a rocking fifth wheel, which allows the trailer to conform to the unevenness of the road but prevents it from swaying sidewise, thus eliminating the danger of upsetting.

This is a solution to the problem of disposing of old pleasure cars that have been lying idle. Many of these old cars are now proving their worth as tractors, because the addition of the Rocking Fifth

Wheel which prevents the accidents and dangers of unevenness in the fields.

Interesting and profitable information may be obtained on this subject by writing to the Martin Rocking Fifth Wheel company, Springfield, Mass., U. S. A.

When you write to advertisers in reference to anything advertised here, please mention The American Blacksmith.

#### "Bay State" Carriage and Tire Bolt Ratchet Wrenches

Labor Savers!  
Money Savers!



Three Sizes  
Take Hex and Square Nuts  
Ask Your Dealer

GEO. A. CUTTER, Sales Agent, Taunton, Mass.

### Butterfield's Screw Plates

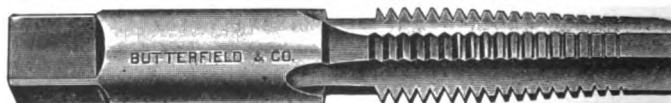

We do not claim to be the oldest manufacturers of Screw Plates. We are not sure that this is any distinction.

Our claims for the superiority of our TAPS and SCREW PLATES are based on actual performance. The rapid growth of our business, is proof positive of the excellence of our product.

Be sure you ask for BUTTERFIELDS, and take no substitute.

NEW YORK STORE 126 Chambers Street BUTTERFIELD & CO. DERBY LINE, VT., U.S.A.



# SKOW'S ROTARY DISC SHARPENER

## is a big Money Maker in any Shop

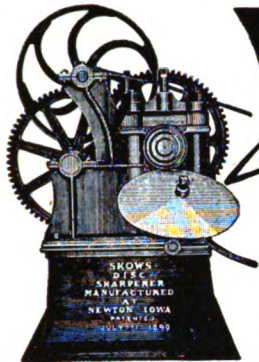

**MADE \$229.50 IN A LITTLE OVER 2 MONTHS**

We shipped this machine from factory on January 10th, 1914

SKOW MFG. CO., Newton, Iowa.

Dear Sirs:—We have sharpened 78 discs on our "Skow Roller" to date, which brings us \$229.50 and the end is not yet. Now can you make us a casting like No. 15 with the shank straight up for rolling coulters. We have tried them on the roller and it is O. K., but should have the casting No. 15 as above mentioned. Let us hear from you if you can make us one. Send us your bill and we will remit for same.

Nora Springs, Iowa, March 18, 1914.

VOLKMAN & SEAMAN.

700 of these machines in use. Sharpens cultivator and plow discs of all sizes by cold rolling. Gives a better and more permanent sharp edge than is possible by any other method.

Ask Your Jobber For Skow's Rotary Disc Sharpener.

Write Us For Descriptive Circulars.

SKOW MANUFACTURING CO.,

::

Newton, Iowa, U. S. A.

## Quick Auto Spring Repairs

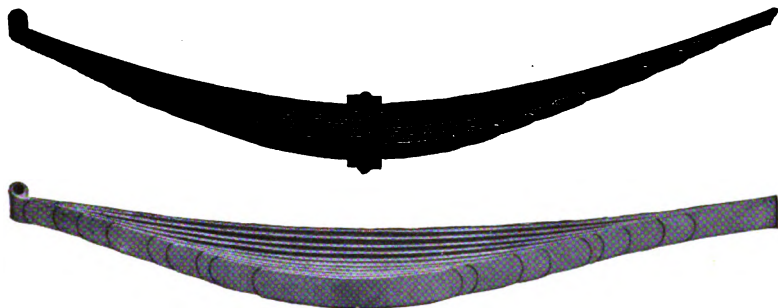

HERE is something that you need every day. Bundles of semi-finished spring repair plates. A large assortment to choose from. A main leaf with eye turned at one end, with each bundle.

Send for free copy of the Harvey Auto Spring Catalog. This book completely describes the Harvey repair plates, gives specifications and prices. Besides it gives complete specifications of over 600 different auto springs to fit nearly every known car. Over 15,000 Harvey "Boltless" Auto Springs in stock constantly to give you service.

HARVEY SPRING & FORGING CO.,

RACINE, WIS.

# TITAN Kerosene Engines

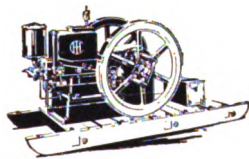

TITAN ENGINES, in 4, 6, 8, 10, 12, 15, 20, 25, 35 and 50-H. P. sizes, operate on kerosene and other cheap low grade fuels, working as efficiently as the best gasoline engines, at a remarkable saving in fuel cost at present prices. Kerosene is also safer than gasoline as fuel. Ask your insurance man.

The service you can get from this Company is an item worth considering. We have branch houses in eighty-seven principal American cities, one of them not far from you, where complete repair stocks and expert help are available. It is a serious and unique accident that puts an INTERNATIONAL HARVESTER TITAN engine out of commission for more than twenty-four hours.

Write to the address below and we will put you in touch with the nearest branch house, from which you will receive complete information.

**International Harvester Company of America**  
(Incorporated)  
13 Harvester Building Chicago U S A

## Shop Equipment & Tools

### Automobile Supplies and Accessories

For the

DEALER

GARAGE

BLACKSMITH

LARGEST STOCK  
QUICK SERVICE

REPAIR SHOP

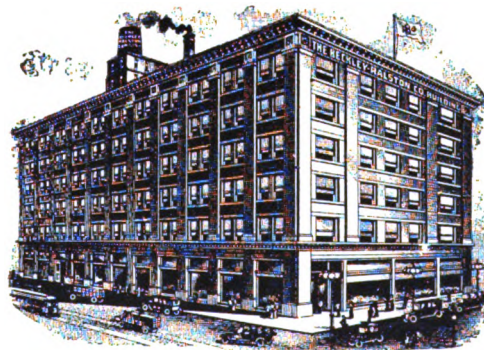

ESTABLISHED 20 YEARS

**THE BECKLEY - RALSTON CO.**

(Wholesale Only)

1803 Michigan Boulevard,

::

CHICAGO

OUR MONTHLY "BUYER'S GUIDE" keeps you in touch with the market — latest prices, new goods and special bargain lists. Do you receive it each month? A postal will bring it.



## LET BANNER BOY STOP AT YOUR SHOP!



You are in for a big surprise. When you let Banner Boy bring you a liberal FREE sample of Banner Welding Compound your welding troubles will end, guess work will have changed to certainty, and there will be a good profit in every welding job.

With Banner you can weld at lower temperatures. There are no hard scales or falling compound while heating. And each weld is perfectly even and smooth.

But don't take our word for this—prove it yourself.

Write us your address and that of your jobber—the Big Free Sample will come by return mail. Nearly all jobbers have Banner. Get it now.

**THE CORTLAND SPECIALTY CO., CORTLAND, N. Y.**

## HERE'S THE HANDY HELPER EVERY SMITH NEEDS DAILY

Time, trouble and exasperation can be saved every time you sharpen heel and toe calks, pull off old toes, knock out sickle sections, upset thin iron, bend angles or such other work as hot rasping, steel plugging, turning ordinary mud calks or traveling tires by using this

### Improved Fuller Foot Vise

No matter how thick the stock this vise, unlike the ordinary foot vise, locks instantly with a light, even pressure. Its great grip is equalled only by a heavy screw vise. Write for complete details or ask your jobber.

**C. & E. MANUFACTURING COMPANY  
MARSHALLTOWN, IOWA**

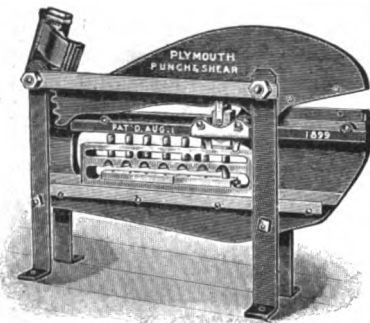

## Every Blacksmith and Repair Shop

should save time, money and hard work by having a

### PLYMOUTH PUNCH AND SHEAR

The only machine that will punch seven different size holes without removing the punches from the machine. Automatic sliding punch rack, no wrench required. Don't accept any other just as good.

Ask your supply house for circular and price or write to the

**PLYMOUTH FOUNDRY & MACHINE CO.  
PLYMOUTH, WIS.**

## TURN THAT STREAM OF PROFITS INTO YOUR SHOP

Why longer let the good money in oxy-acetylene welding pass on to another shop? It is ready to stop at your door if you do the work. And all you need do to capture these good extra profits and make a welding reputation for your shop is to put in this

### IDEAL WELDER

Then you are ready to tackle the largest or smallest welding jobs with complete success. And you do not have to make a large investment—the IDEAL outfit is low priced enough to pay for itself in an unusually short time.

You will be well repaid if you write immediately for complete information regarding the IDEAL outfit.

**GENERAL WELDING CO.  
394 14th Street, Hoboken, N. J.**



If you have never learned by actual experience just how good **Pioneer Shaft Ends** are, do it now by ordering a few of your jobber, and don't let him pawn off on you the "just-as-good," "may suit" brand. Look for the Pioneer trade-mark on the wrappers. Possibly you order a certain kind of horse nails and shoes because they are better and please. So why not specify **Pioneer Shaft Ends** for the same reason? Once you get acquainted, they will be your affinity ever afterwards.

**Pioneer Shaft Ends** are the kind that are easy to fit, and make the strongest joint.

**THREE SIZES:—BUGGY, SURREY AND LIGHT BUGGY.**

Made by **CRANDAL, STONE & COMPANY, BINGHAMTON, N. Y.**

"First Made in America."

## Hay-Budden Solid Forged Anvils

HAY-BUDDEN MFG. CO., Brooklyn, N. Y.



**200,000 IN USE.**

Entire top being in one piece of high-grade forged steel, makes a loose face impossible.

## The Nail For Your Shop—

of course you want the best— is The Capewell.

**Capewell  
Horse  
Nail**  
—  
**Drives  
Easiest**

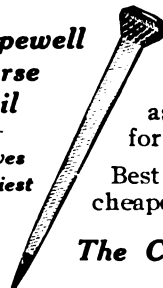

Famed for superior driving qualities—for being safe and economical as well—The Capewell is the stand-by for the majority of horseshoers.

Best nail in the world at a fair price, not cheapest regardless of quality.

**The Capewell Horse Nail Company  
Hartford, Conn.**

*Largest Makers of Horse Nails in the World*

# AMERICAN BLACKSMITH

A Practical Journal of Blacksmithing and Wagonmaking

BUFFALO  
N.Y., U.S.A.

NOVEMBER, 1916

\$1.00 A YEAR  
10c. A COPY



PACKED IN EACH CARTON OF  
**ROWE CALKS**



are of substantial value and readily redeemed

THAT IS ONE REASON WHY

**You Should Sell Golden Rustless Ring-Points**

They are the Calks with the Centers of Tool Steel, Welded in Place and Scientifically Hardened, Making Them Wear Sharp and Last Long

**Do Not Delay. Order Your Supply of Rowe Calks for the Coming Hard Winter**

**WE STILL PROTECT HORSESHOERS**

**The Rowe Calk Company**  
Plantsville, Connecticut.

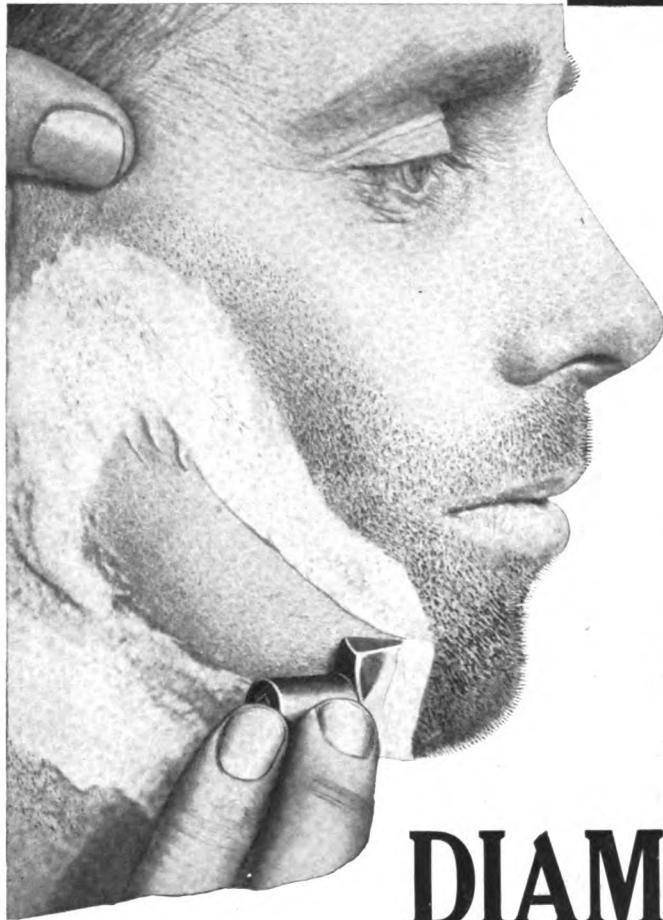

Another Test  
of the  
Remarkable Quality  
of Steel Used in

# DIAMOND Calks

**T**HIS man's heavy, tough beard was shaved with one of our regular standard blade sharp calks (ground and honed to a razor edge).

Only a razor edge could shave such a beard and nothing but the best quality steel could take on a real razor edge.

Superior Quality in the materials used,—perfection in the general design of the calks together with the Mechanical Accuracy in their fit, have placed the DIAMOND line in a class by themselves.

There's a DIAMOND CALK for every purpose.

Only horseshoers retail them.

*Ask for illustrated Catalogue and Price List.*

**Diamond Calk Horse Shoe Company**

**Duluth, :: Minnesota**

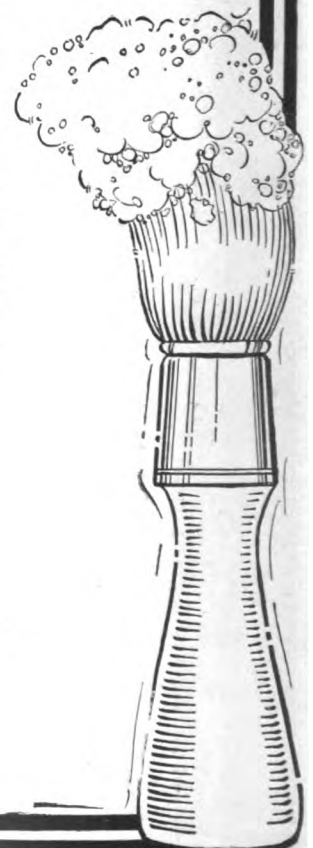
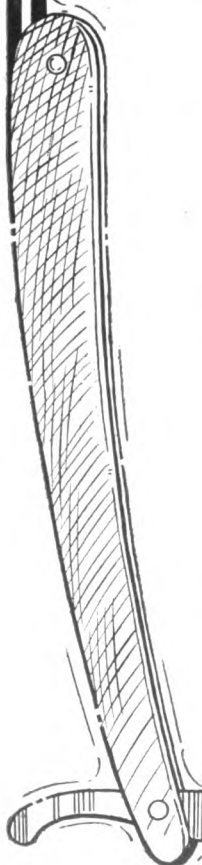

*W. A. Calk*

# AMERICAN BLACKSMITH

A Practical Journal of Blacksmithing and Wagonmaking

BUFFALO  
N.Y., U.S.A.

DECEMBER, 1916

\$1.00 A YEAR  
10c. A COPY

**A**  
*Mark of  
Quality*

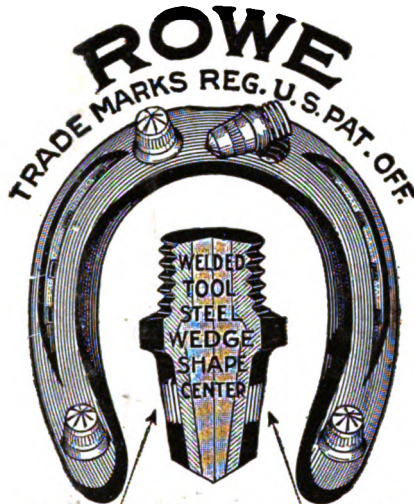

**A**  
*Sign of  
Service*

**RING-POINT**  
TRADE MARK REG. U.S. PAT. OFF.  
**"GOLD" CALKS**

Are manufactured expressly for the Owner who recognizes the endurance value of a Sharp Shod Horse.

The Winter is at Hand

**Be Sure Your Stock is Complete**

DO NOT FORGET

**ROWE DRIVE CALKS**

are of recognized superiority

**UNITED PROFIT SHARING COUPONS**

The Coupons of Real Worth

Are Packed in Every Carton

**THE ROWE CALK COMPANY**

Plantsville, Connecticut.

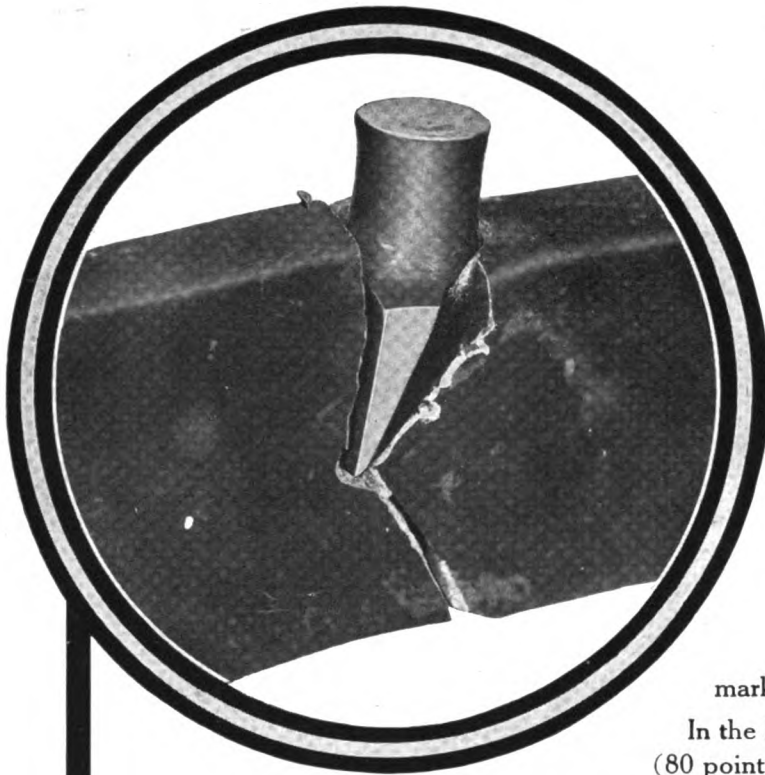

Short Blade or Pad Calk



Standard Blade



Large Blade



3 Sizes of Sharp Calks

## To Prove the Superior Quality of Steel

used in our Calks, these severe and remarkable tests were made.

In the first test we used a piece of 1x3 tool steel (80 point carbon) into which one of our regular standard blade sharp

# DIAMOND      CALKS

was driven as deep as the tongs holding the calk permitted (the photograph shows what happened to the steel--the blade of the calk was merely scratched.)

In the second test, after grinding and honing another standard sharp blade to a razor edge, the edge was so keen that we shaved a man's tough beard with it, and shaved it close too'

Only the hardest and toughest tool steel could stand up under such tests.

That's one reason why they stand the test of hard wear so well,

Only horseshoers retail Diamond Calks.

Ask for new illustrated catalogue and price list.

**Diamond Calk Horse Shoe Company**  
Duluth, Minnesota



Short Blade or Pad Calk



Standard Blade

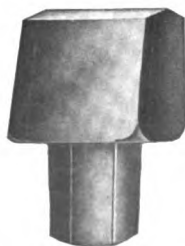

2 Sizes of Dull Calks

# AMERICAN BLACKSMITH

A Practical Journal of Blacksmithing and Wagonmaking

BUFFALO  
N.Y., U.S.A.

JANUARY, 1917

\$1.00 A YEAR  
10c. A COPY

## You Can Weld Steel As Easily As Iron



### Climax Welding Compound

Especially adapted for welding tires, axles, springs, and all lap welding. Designed to be applied between the lap. Welds at a low heat and always sure. All its name implies—THE CLIMAX OF WELDING COMPOUNDS.



### Borax-Ette

A flux which causes steel to weld like iron. Not necessary to apply between the lap, but may be applied to the outer surface of the work. Has no equal for plow work. Just the thing for welding toe-calks so they can't knock off. A flux for every job of welding.

Owing to our improved process of manufacturing, these compounds do not boil off and waste in the fire, but adhere to the hot metal when applied.

For sale by all leading dealers in blacksmith supplies in the United States and Canada.

Large FREE sample sent on request.

**Cortland Welding Compound Co.**  
**CORTLAND, N. Y.**



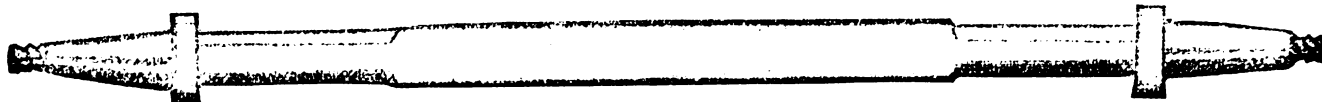

# Mr. Blacksmith---

If you could add four men to your shop, pay their wages for a month and get their services free for the next fifty years, it would be a pretty good investment, wouldn't it?

Well that's just what you can do with a

## ROCHESTER Hard Hitting Helve Hammer

in your shop, if you do an average amount of forging, welding, swaging and similar work. The smallest size not only does the work of four men quicker and better than by hand, but handles special die work that is impossible to do without machine power.

It is the power hammer with a blow nearest like that of the smith's. The wooden helve gives a quality of blow that can be had in no other way, just as the fine hickory handled mechanic's hammer gives a better blow than an iron handled would do. The springy forging blow of the

ROCHESTER HAMMER not only gives more efficiency for the same power expended but improves the quality of the metal in the work as well. This cushion stroke produces the genuine forging blow rather than the drag or dead blow which should always be avoided in power hammers.

An exclusive feature of the ROCHESTER HAMMER is a simple shifting device which permits a quick change from the long slow stroke to the short, rapid one—while the hammer is running. This gives complete control of the hammer, so that the thinnest and thickest stock can be handled without a moment's loss of time.

Write us full particulars regarding the work to be performed in your shop and size of stock to be handled and let us recommend the size of hammer best adapted to your work.

*Catalog free on request.*

### The West Tire Setter Company

*Manufacturers of the Celebrated West Hydraulic Tire Setters*

**Rochester, N. Y., U. S. A.**

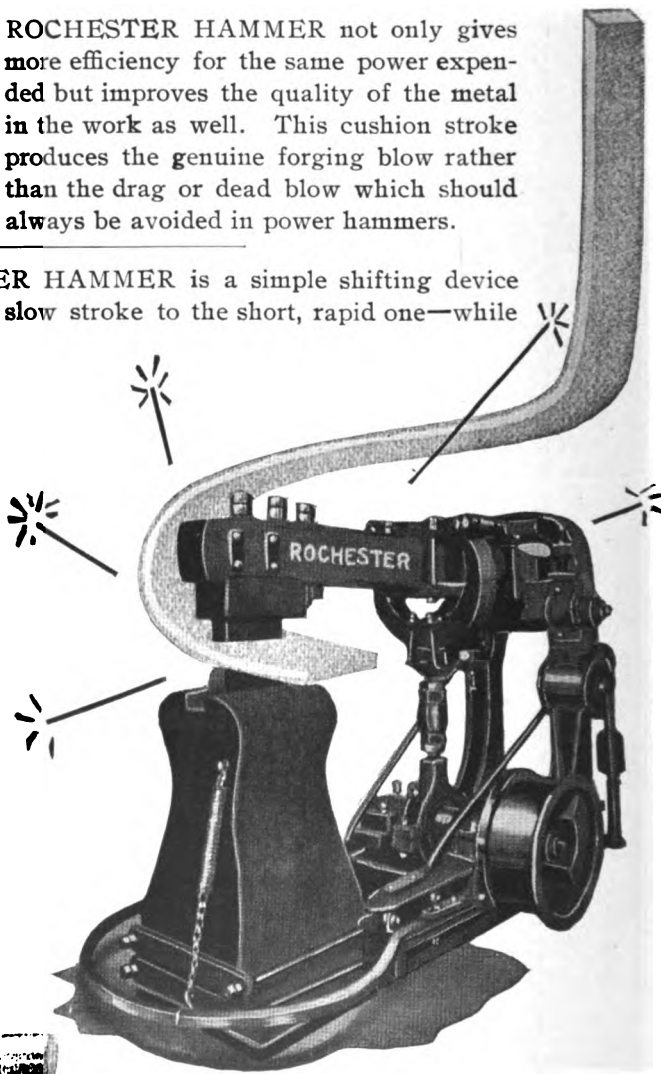

1917

# AMERICAN BLACKSMITH

A Practical Journal of Blacksmithing and Wagonmaking

BUFFALO  
N. Y., U. S. A.

FEBRUARY, 1917

\$1.00 A YEAR  
10c. A COPY

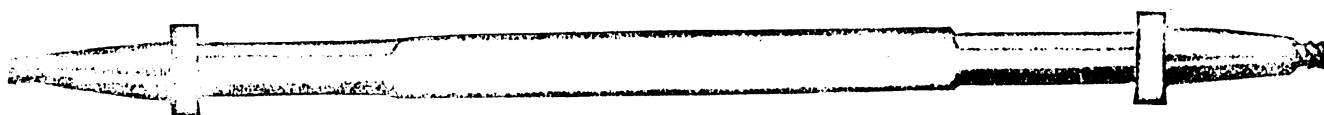

## Mr. Blacksmith—

If you could add four men to your shop, pay their wages for a month and get their services free for the next fifty years, it would be a pretty good investment would'nt it?

Well that's just what you can do with a

## ROCHESTER Hard Hitting Helve Hammer

in your shop, if you do an average amount of forging, welding, swaging and similar work. The smallest size not only does the work of four men quicker and better than by hand, but handles special die work that is impossible to do without machine power.

It is the power hammer with a blow nearest like that of a smith's. The wooden helve gives a quality of blow that can be had in no other way, just as the fine hickory handled mechanic's hammer gives a better blow than an iron handled would do. The springy forging blow of the

ROCHESTER HAMMER not only gives more efficiency for the same power expended but improves the quality of the metal in the work as well. This cushion stroke produces the genuine forging blow rather than the drag or dead blow which should always be avoided in power hammers.

An exclusive feature of the ROCHESTER HAMMER is a simple shifting device which permits a quick change from the long slow stroke to the short rapid one—while the hammer is running. This gives complete control of the hammer, so that the thinnest and thickest stock can be handled without a moment's loss of time.

Write us full particulars regarding the work to be performed in your shop and size of stock to be handled and let us recommend the size of hammer best adapted to your work.

Catalogue free on request.

### The West Tire Setter Company

*Manufacturers of the Celebrated West Hydraulic Tire Setters*

Rochester, N. Y., U. S. A.

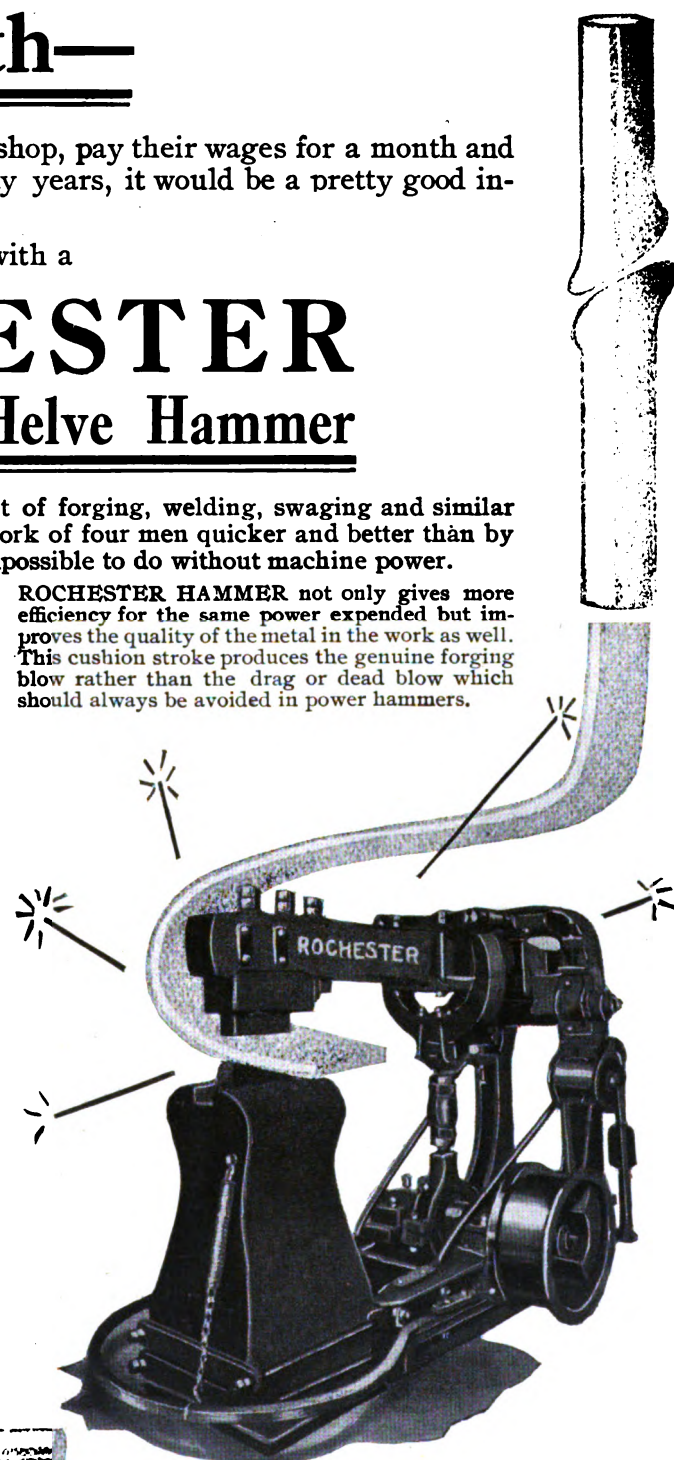

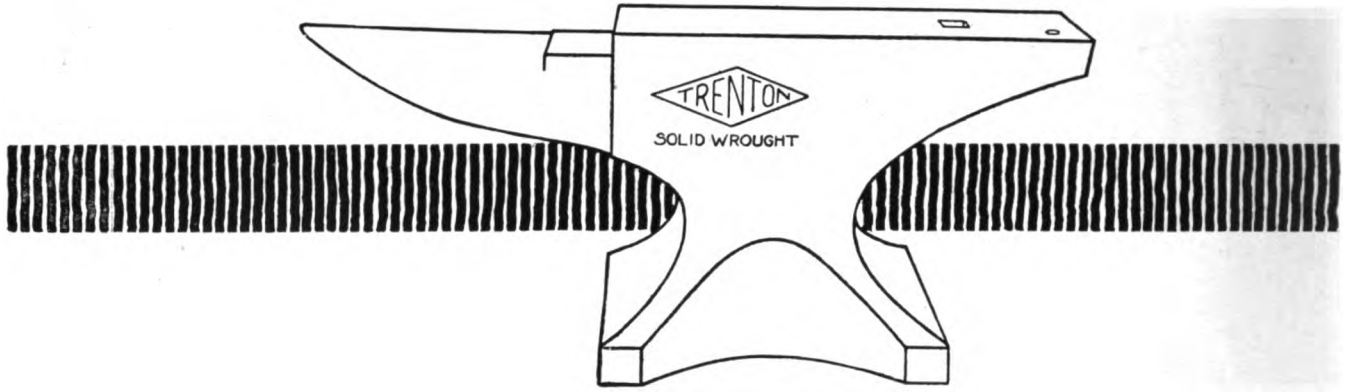

# The Blacksmith's Love

*---a little tribute to Trenton Anvils*

By W. O. B.

A shapely Venus did'st thou say?  
 Ah, gaze, and check your haste.  
 Oh, man! Hast beauty in thy eye?  
 Can'st tell a shapely waist?

Then look upon a face so rare,  
 'Tis rapture, joy, delight:  
 As smooth as velvet to the touch—  
 Intoxicates the sight.

Hast heard St. Peter's bells in Rome?  
 If not, then none can tell  
 Thee what a voice my fair one has—  
 I'll say 'tis like a bell.

Would'st shyly glance upon a heel?  
 Gaze not too long, I pray.  
 I know 'tis neatly shaped and well.  
 But sometimes sense will stray.

Such witching charms as these, think you,  
 Not bring love to the heart?  
 Enchantment binds me hard and fast—  
 Sweet bonds we do not part.

Say'st thou that love ne'er touch thy heart?  
 'Twould do thee no great ill,  
 If thou but had'st a love like I—  
 Love for an old anvil.



The **Trenton Anvil** is a delight to the trained smithing eye. It is built the way a smith knows an anvil should be built---not of old, dead scrap, cast into shape, but solid wrought from new steel---full of life and spring. It's recessed base gives lightness and unusual stability---no strops are needed to hold it down, even though heavy work is being handled at the end or heel.

Let your jobber show you his line of **Trentons** or write for catalog.

**The Columbus Forge and Iron Company, Columbus, Ohio**

*Manufacturers of the famous "Indian Chief" Solid Box Vises.*



# AMERICAN BLACKSMITH

A Practical Journal of Blacksmithing and Wagonmaking

BUFFALO  
N.Y., U.S.A.

MARCH, 1917

\$1.00 A YEAR  
10c. A COPY

**I WANT TO SEND  
YOU A FREE  
SAMPLE BOX  
OF  
CORONA**

*C. G. Phillips  
The Wool Fat  
Man*

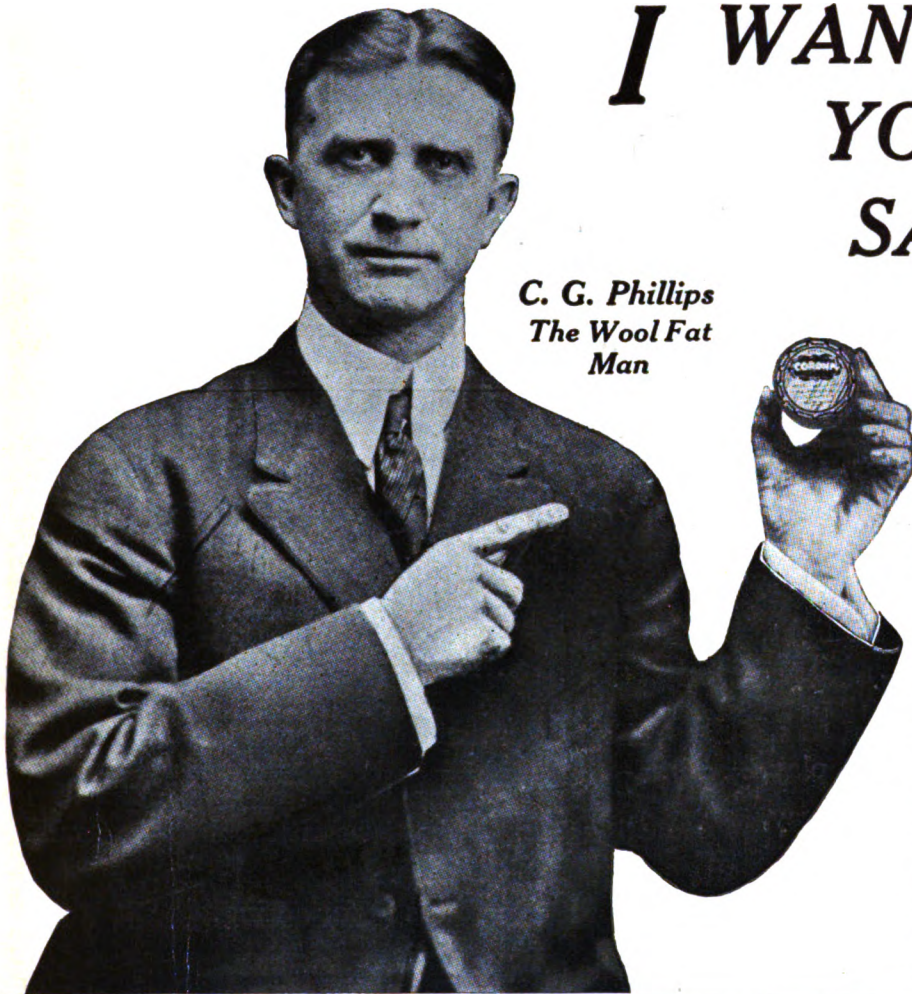

**I KNOW CORONA—I KNOW WHAT IT  
WILL DO FOR CATTLE AND HORSES  
AND I KNOW WHAT IT WILL DO FOR  
YOU AND YOUR BUSINESS.**

**THIS SAMPLE BOX IS WAITING FOR  
YOU—I WANT YOU TO HAVE IT.**

**GIVE ME YOUR ADDRESS ON THE COUPON  
TODAY AND WHEN I SEND THE BOX I WILL TELL  
YOU HOW CORONA WILL MAKE MONEY FOR  
YOU. ALSO GIVE NAME OF YOUR FAVORITE  
JOBBER.**

I want blacksmiths and horseshoers all over the country to act as my agents. CORONA is a money maker for the horseshoer. I know what I'm talking about. If I didn't, would I back up CORONA with such a strong guarantee? Would I offer you a free sample for trial if I didn't know that CORONA is positively the best article of its kind on the market today? I stand back of every can, just as I stand here holding out this free can for you.

Be the first in your town to look into this money making proposition. Will you give me a chance to prove CORONA to you?

**The Corona Mfg. Co.,**

**Lock Box "A"**

**Kenton, Ohio**

CORONA WOOL FAT is recommended for the worst cases of Cracked Hoof, Grease Heel, Corns, Mud Fever, Scratches, Gall Shoulder, Barbed Wire Cuts, Sore Teats of Cows, and all other hoof and skin diseases known to the animal kingdom.

Tear on this line and mail, to  
The Corona Mfg. Co., Kenton, Ohio.

Mr. Phillips:

I have never acted as your agent and will be pleased to give CORONA a good test. Send me a free sample box and tell me how I can make money selling CORONA.

Name .....

Address .....

The name of my Iron Store Jobber is .....

.....

.....

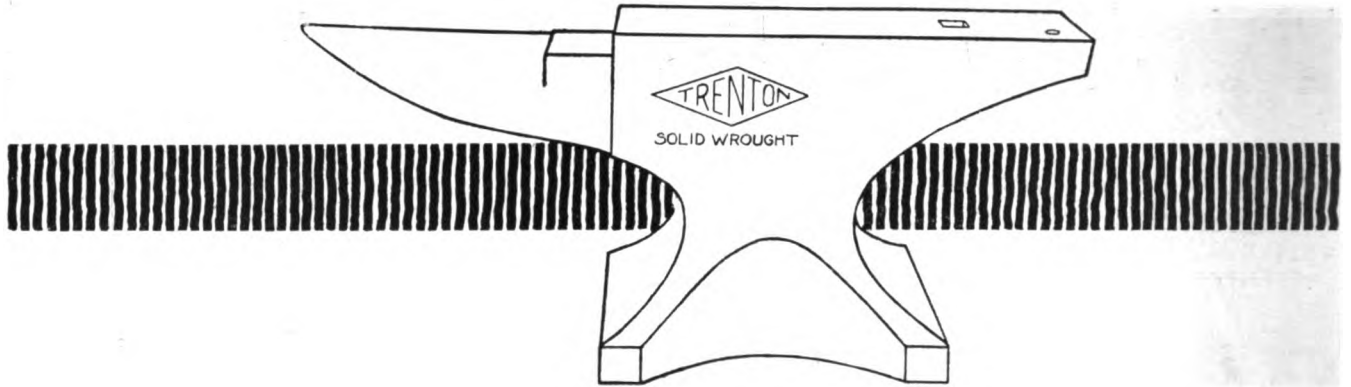

## The Rhyme of an Aspiring Anvil

*Contributed by W. O. B. and H. O. M.*

Oh you who have daring deeds to tell,  
And you who have felt the forge fire's spell;  
Hast heard of the anvil who longed to dwell  
In the blacksmith shop of a king?

He sighed all day, and he longed all night,  
Yet no one could understand it quite;  
For the shop of a smith is an anvil's delight,  
But he pined for the shop of a king.

So he left the forge where he used to play,  
And off by his lonesome, he wandered away,  
Far from the home of his youth so gay,  
To look for a place with a king.

The king he spake to his helper, Jim:  
"Look brisk, you mutt, my eyes are dim;  
Is that an anvil a-slinkin' in,  
Or is tea too strong for a king?"

And lo! Jim looked—with standing hair  
And frightened eye—he could but stare;  
"Aye, sire, 'tis true. My word!—and rare,  
For an anvil to visit a king."

But when they saw that our hero bold  
Bore "**TRENTON**" carved in letters of gold;  
They bound him tight with chains that would  
hold,  
For a Trenton is fit for a king.



Yea, verily; a *Trenton Anvil* is fit for any king. And it was made for the king of all artisans---that worthy knight of the noblest craft---the village blacksmith.

Built for the finest shop in the land. There's not a particle of scrap or dead waste metal in its composition. It's wrought from solid steel---full of life and spring, "rings like a bell."

*Let your jobber show you his line of TRENTONS,  
or write us for Catalog*

**The Columbus Forge and Iron Company, Columbus, Ohio**

*Manufacturers of the famous "Indian Chief" Solid Box Vises.*



# AMERICAN BLACKSMITH

A Practical Journal of Blacksmithing and Wagonmaking

BUFFALO  
N.Y., U.S.A.

APRIL, 1917

\$1.00 A YEAR  
10c. A COPY

## Columbian

## *Blacksmith*

## *Vise*

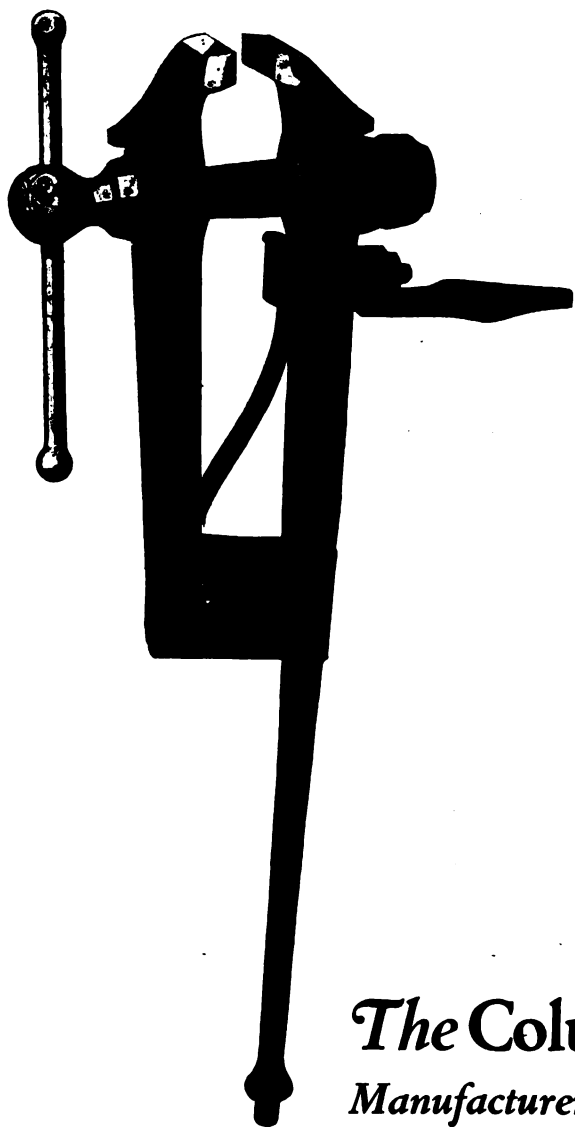

The forged U-bolt yoke, holding the vise firmly to the bench-plate, insures permanent and satisfactory service.

The screw is forged from a single piece of special carbon steel. Washers at wearing-points mean ease of operation.

The spring is tempered steel, sprung to develop full opening-capacity.

Each jaw is forged complete from a solid billet. Welds are used at two points only, the hinge-plate, and the jaw-faces.

Broad and long is our guarantee. Simply this: At any time, under any conditions, we will send a new vise to replace one that, in the users' opinion, is not giving satisfactory service.

***The Columbian Hardware Co.***

*Manufacturers*

Cleveland, Ohio



**HAVE YOU SEEN SNAPS?**

## Let "SNAPS" Point The Way to New And Bigger Profits

There isn't a single automobile in the entire nation that doesn't frequently require some supplies or equipment. This year there will be *more than 4,000,000 cars* in service. Who will get the money that their owners will spend for auto parts and accessories?

Think how much more money you could make if you stocked auto supplies. Your *established* business is the logical place for people who need auto supplies to look for them. *Hundreds of blacksmiths* are selling auto supplies and find they are making 100% profit *easily*—and *even more*.

### START SELLING AUTO SUPPLIES AND MAKE BIG PROFITS

Mind you, you don't have to carry a big stock of auto supplies because we help you at *every stage of the game*. You buy *by mail* from our monthly catalog "SNAPS," which is known the country over as the "National Bargain Directory of Auto Supplies." We carry your stock for you and guarantee to fill 90% of all orders *within six hours* after receipt.

Get your copy of "SNAPS" now. "SNAPS" is our catalog and we send it fresh and new to our dealers on the first of each month. "SNAPS" is all that its name implies—full of *snaps* in high-grade auto supplies and accessories—things any motorist requires.

Our prices are remarkably low—you will recognize that just as soon as you lay eyes on "SNAPS." But don't take our word for it. Write us *now* to send you your copy of "SNAPS."

Remember, we sell to dealers only. We positively will not sell to consumers, so when you write use your letterhead so we can tell you are a *recognized blacksmith* who intends to buy auto supplies to *re-sell* them at a profit.

**SERVICE MOTOR SUPPLY CO. 1523-25-27-29-31 MICHIGAN AVE. CHICAGO, U.S.A.**

# AMERICAN BLACKSMITH

A Practical Journal of Blacksmithing and Wagonmaking

BUFFALO  
N.Y., U.S.A.

MAY, 1917.

\$1.00 A YEAR  
10c. A COPY

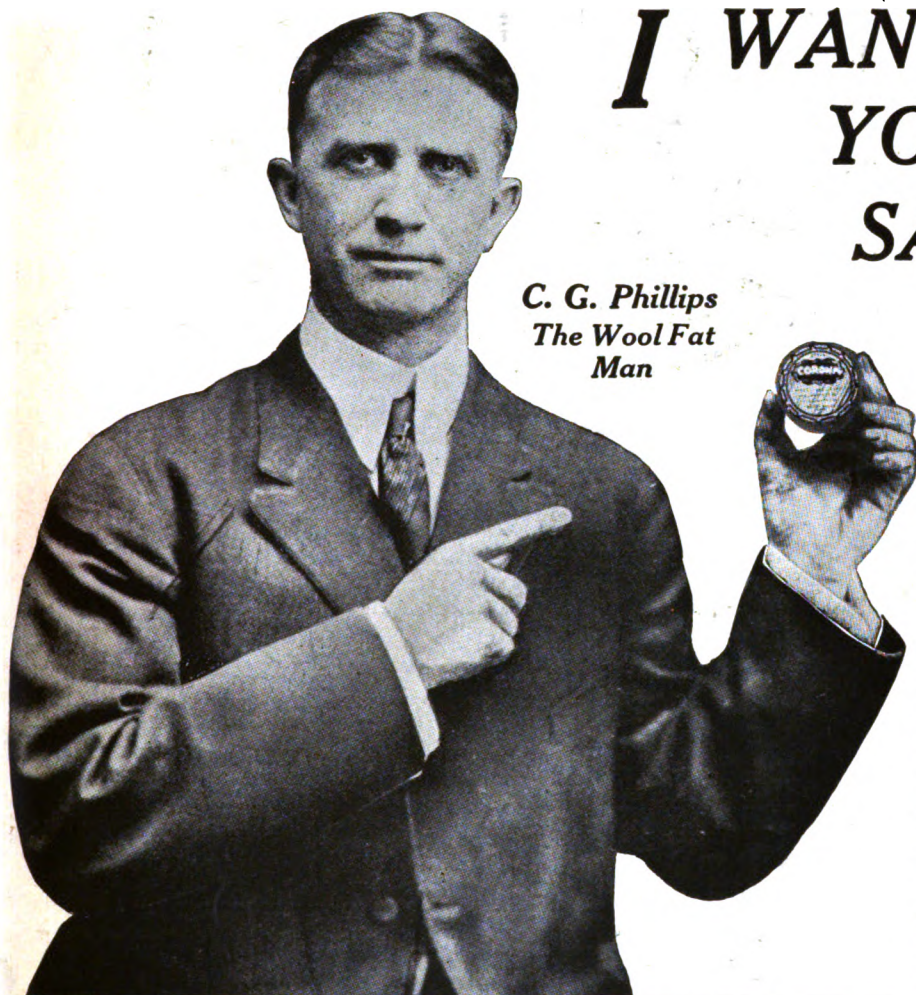

*C. G. Phillips  
The Wool Fat  
Man*

## I WANT TO SEND YOU A FREE SAMPLE BOX OF CORONA

I KNOW CORONA—I KNOW WHAT IT WILL DO FOR CATTLE AND HORSES AND I KNOW WHAT IT WILL DO FOR YOU AND YOUR BUSINESS.

THIS SAMPLE BOX IS WAITING FOR YOU—I WANT YOU TO HAVE IT.

GIVE ME YOUR ADDRESS ON THE COUPON TODAY AND WHEN I SEND THE BOX I WILL TELL YOU HOW CORONA WILL MAKE MONEY FOR YOU. ALSO GIVE NAME OF YOUR FAVORITE JOBBER.

I want blacksmiths and horseshoers all over the country to act as my agents. CORONA is a money maker for the horseshoer. I know what I'm talking about. If I didn't, would I back up CORONA with such a strong guarantee? Would I offer you a free sample for trial if I didn't know that CORONA is positively the best article of its kind on the market today? I stand back of every can, just as I stand here holding out this free can for you.

Be the first in your town to look into this money making proposition. Will you give me a chance to prove CORONA to you?

Tear on this line and mail, to  
The Corona Mfg. Co., Kenton, Ohio.

**The Corona Mfg. Co.,**  
**Lock Box "A" Kenton, Ohio**

Mr. Phillips:  
I have never acted as your agent and will be pleased to give CORONA a good test. Send me a free sample box and tell me how I can make money selling CORONA.

Name .....  
Address .....  
The name of my Iron Store Jobber is .....  
.....  
.....

CORONA WOOL FAT is recommended for the worst cases of Cracked Hoof, Grease Heel, Corns, Mud Fever, Scratches, Gall Shoulder, Barbed Wire Cuts, Sore Teats of Cows, and all other hoof and skin diseases known to the animal kingdom.





Have You Seen

"SNAPS?"

**This year will see more than 4,000,000 cars in service!** \$350,000,000 will be spent in 1917 for auto supplies. Who will get the money their owners will spend for auto parts and accessories?

**Twenty dollars a car would be a mighty small estimate of the money that auto owners will spend this year for automobile accessories and supplies.** Yet, figured even on this *ultra-conservative basis*, it totals \$80,000,000. But, mind you, \$80,000,000 is only a fraction of the *real* figures.

**Think how much MORE MONEY you could make, if you stocked auto supplies!** Your established business is the *logical* place for people who *need* automobile supplies to *look for them*.

100% Profit Easily

**On auto supplies you can make 100% and EVEN MORE.** And mind you, you don't need to clutter up your store space with *big stocks*. We're in reality a big Chicago partner at your service. We help you *at every stage of the game*. You buy by mail from our monthly catalog, "SNAPS," which is known the *country over* as the "National Bargain Directory of Auto Supplies." We carry your stocks for you and *guarantee* to fill 90% of all orders within *six hours* after receipt. Only in the case of special orders do we fall behind on this schedule.

**"SNAPS" is YOUR catalog.** We send "SNAPS" **FRESH and NEW** to our dealers the first of every month—and *we sell to dealers only*. "SNAPS" is all that its name implies—full of *snaps* in high-quality auto supplies and accessories—*everything* any motorist ever requires. Decide now to make new and bigger profits. Send in an order from this issue of "SNAPS" today! (24)

**SERVICE MOTOR SUPPLY CO. 1523-25-27-29-31 MICHIGAN AVENUE. CHICAGO, U.S.A.**

# AMERICAN BLACKSMITH

A Practical Journal of Blacksmithing and Wagonmaking

BUFFALO  
N.Y., U.S.A.

JUNE, 1917

\$1.00 A YEAR  
10c. A COPY



**PACKED  
ROWE**

**WITH  
CALKS**

***Insure Your Horse Against Accident***

*With*

## **GOLDEN RUSTLESS RING-POINTS**

The hard tool steel center of Ring-Point Calks is welded to the casing. It simply can't fall out. The "Golden" plating keeps them free from rust and protects the thread. They are easy to put in, and easy to take out. Ring-Points give real service. They wear longer and are sharper than any other calk.

These are not the only calks we make. Don't forget the famous

### ***ROWE DRIVE CALKS***

made of high grade steel, correctly tapered and with absolute uniform shanks. With these calks your horse will be sure-footed in all kinds of weather.

United profit-sharing coupons in each carton of Rowe Calks.

*Send for price list and free advertising helps.*

**THE ROWE CALK COMPANY**  
**PLANTSVILLE, CONN.**

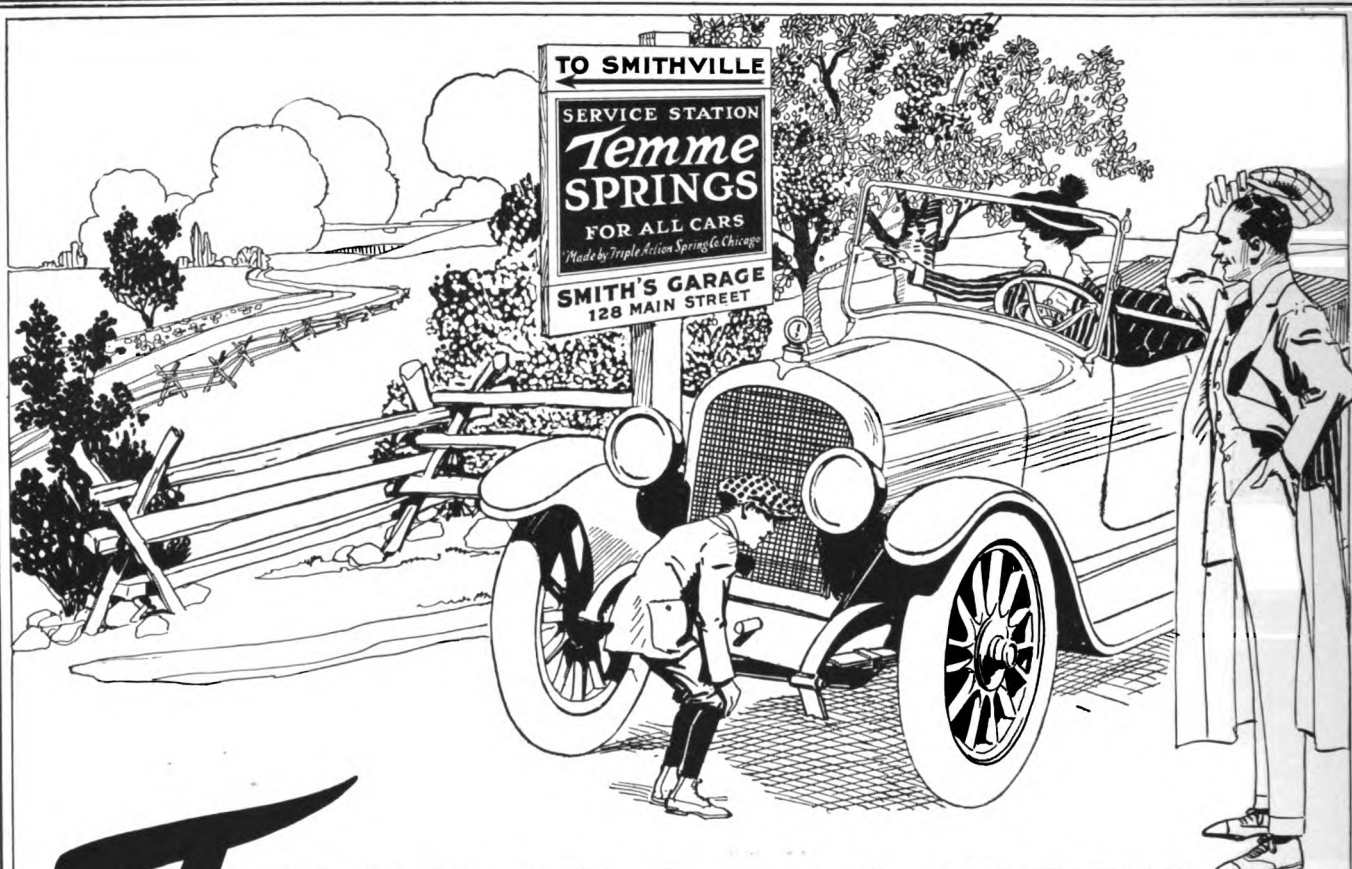

# Temme SPRINGS FOR ALL CARS



**JOHNSON**  
Shock Absorber

**T**HE picture tells the story. Are you the Mr. Smith of Smithville? Are your highway signs on all your roads?

Do all the lame cars drive to your door for Temme Springs and other things?

If you are not Smith, who is? Or who will be? That's the question.

And in most good towns it will be answered soon. For Temme Springs and Temme's Triple Action Service are known to be as good as gold.

Hundreds of repairers, who have "banked" on Temme and never lost, are putting up these Temme highway signs today.

These signs will bring in business. Temme has tried them, so he knows. And now he offers you what won for him.

This is to remind you of the new model of the famous Johnson Shock Absorber—made by us. The only cure for a hard riding car is a pair of Johnsons. Temme Spring Service Stations make good money on them. Write now for our new proposition.

Temme Springs "for all cars" means just what it says—for all cars since 1902. Test us by naming the spring you need. Temme Triple Action Service will have it on the way to you the same day.

"For all cars" means designed for all cars to factory specifications. And so good are Temme Springs—so prompt the service—so fair the prices—that dealers in all cars now buy from Temme in preference to the car maker.

You need these springs, this service, these signs. They will make you money, bring new business, help you build the good reputation you are after.

If you delay you may lose this exclusive proposition. Write or wire us now, saying: "Send Temme Spring Service Station proposition at once."

**TRIPLE ACTION SPRING COMPANY**  
77 East 28th Street, Chicago

# AMERICAN BLACKSMITH

A Practical Journal of Blacksmithing and Wagonmaking

BUFFALO  
N.Y., U.S.A.

JULY, 1917

\$1.00 A YEAR  
10c. A COPY



## ROWE CALKS

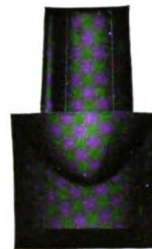

THE CALKS YOU WILL  
WANT TO USE IF YOU VALUE THE  
GOOD-WILL OF YOUR CUSTOMERS.

### Good-Will Means More Business

and we all need each others' Good-Will.

☞ Besides knowing they are using the Best Calks made, Horseshoers using ROWE Screw and Drive Calks are assured of Maximum Protection because of our long standing policy of selling only to Blacksmith Supply Houses under our own labels.

☞ This is one of the basic reasons why we have been able to hold the Good-Will and Confidence of the Horseshoers of America.

THE ROWE CALK COMPANY  
PLANTSVILLE, CONN.



# I will save you \$69.60 on a CURB TANK OUTFIT if you act QUICK

**W. H. DUTTON, Pres.**  
**Tokheim Mfg. Company.**

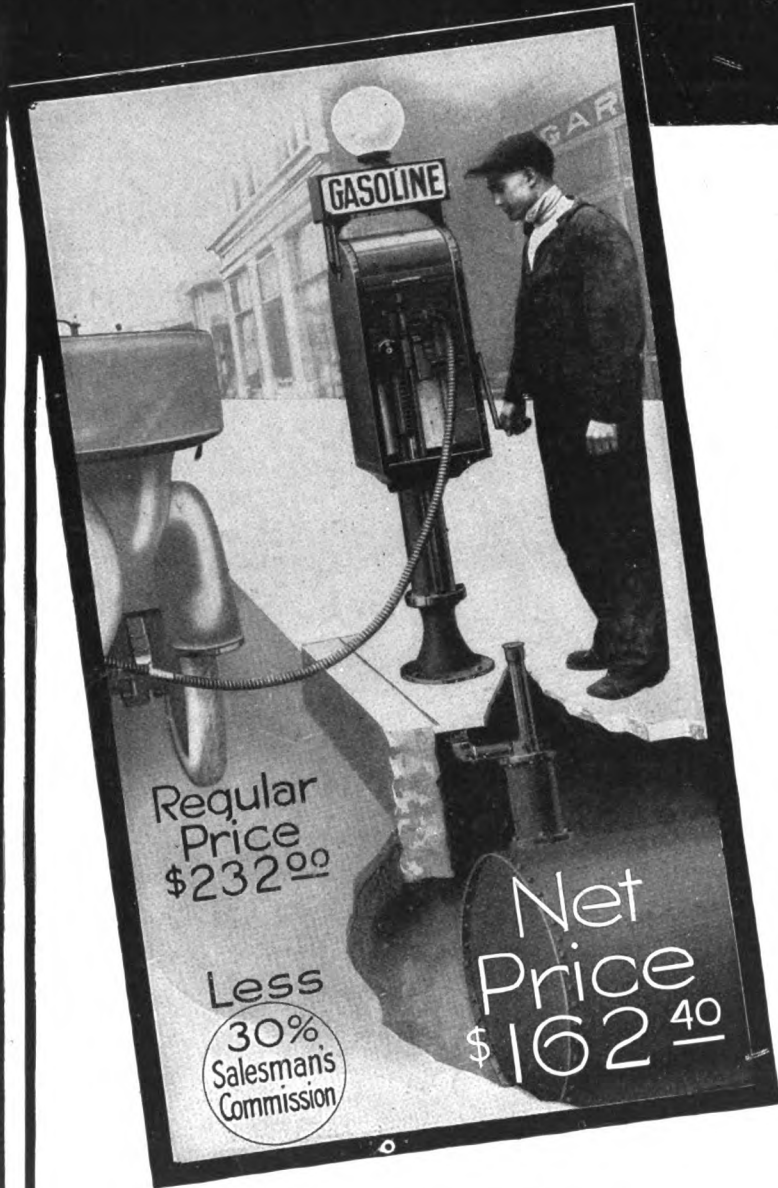

Here is your opportunity to put in a guaranteed, time-tested and proven Curb Tank at a saving of 30% under regular prices. For only \$162.40, 30% less than my regular price, I will send you a Tokheim 10-gallon-a-minute outfit, with 290 gallon storage tank, exactly as pictured. This outfit is absolutely the same as Tokheim Outfits in use all over the country.

My reason for this unparalleled offer is this. I have offered to turn over my plant to the Government and should the call come, my tank business will be put aside. I have completed a certain number of outfits. These represent a big investment in materials and money. I want to move them, do it quick, and I am going to do it by cutting out all salesman's commissions and dealing direct with the man who needs a Curb Tank Outfit.

Remember this — Tokheim outfits are standard — in use today by big concerns like Armour & Co., Union Pacific R. R., Wm. Wrigley Co., also the U. S. Government. Tokheim outfits have been sold for 16 years. I mention this so that you may have confidence in what I say.

This is your opportunity to save \$69.60 on a \$232 outfit. You can't duplicate it elsewhere for \$250. I bought materials for these outfits at before-war prices and it would be impossible to produce any more at these prices. You know that tank steel has advanced more than 200% over a year ago. So this opportunity will not come again.

I give you the 30% commission that salesmen are paid. It's big interest on your money. I give every garage man and storekeeper who needs one, a real opportunity to save money. I make a square business offer and I advise you that here is an opportunity that will not come again. When these outfits are gone, I can offer no more at anywhere near such prices. Write or wire at once if you want to save \$69.60—30% on a Tokheim outfit. Proportionate saving on other sizes.

### THIS COMPLETE OUTFIT INCLUDES

Exactly as illustrated and guaranteed for one year; Tokheim Curb Outfit No. 24 for Gasoline, with double electric sign 6x19 in., Globe at top 10 inches, Gallon discharge pump, steel curtain door which rolls up and down, fitted with lock. Height 6 feet, 9 inches. Base 13 inches—Housing 15 inches square. Set back tally. 8 ft. best quality gasoline hose and hose nozzle.

Tank: Finest quality galvanized tank steel, No. 14 Gauge, 290 gallon capacity at \$162.40 outfit price—other sizes made from same material.

Tank Fittings: Interior Suction Pipe, Foot Valve, Fill Pipe and parts, Gasoline Strainer, Cap and Lock, Gauge Stick and Pipe Fittings.

### OTHER SIZES

Tank	Regular Price	Net Price
180 Gal.	\$200.00	\$140.00
230 Gal.	220.00	154.00
430 Gal.	293.00	205.10

Low prices on still other sizes quoted promptly

**Address W. H. DUTTON, Pres.,**  
**TOKHEIM MFG. CO.,**  
**815 North First St., W., Cedar Rapids, Ia.**

# AMERICAN BLACKSMITH

A Practical Journal of Blacksmithing and Wagonmaking

BUFFALO  
N. Y., U. S. A.

AUGUST, 1917

\$1.00 A YEAR  
10c. A COPY

## ROWE *SCREW and DRIVE* CALKS



AND  
THE HORSE SHOER  
ARE FRIENDS



### BECAUSE—

HORSE SHOERS only sell ROWE CALKS. No retail stores, no catalog houses, no selling direct to the consumer.

### BECAUSE—

CONSUMERS will call for advertised calks and ROWE CALKS are the best advertised calks.



### BECAUSE—

ROWE CALKS represent highest quality. Note the welded Tool Steel Center.

### BECAUSE—

UNITED PROFIT-SHARING COUPONS, the most useful coupons printed, are packed with ROWE CALKS only, and in every carton.

THE ROWE CALK COMPANY  
PLANTSVILLE, CONN.



**Our Guarantee**  
**THE SAME AT ANY POINT ON SPRING**  
**IT WOULDN'T BE-IF THERE**  
**WERE ANY WEAK SPOTS**

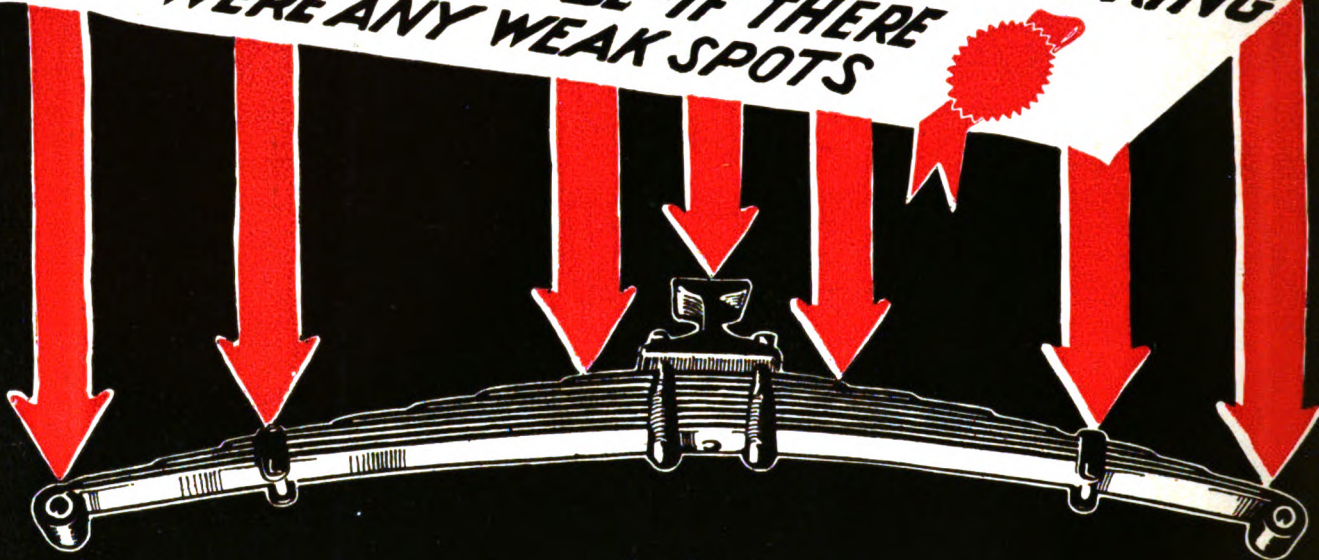

The manufacturer of a spring knows more about his product than any outsider does. His guarantee is going to be just as liberal as quality will allow. So it follows that the broadest guarantee covers greatest spring value. Providing, of course, the guarantee is given by a *responsible* maker.

## Higgins Quality Springs

FOR REPLACEMENT

are guaranteed alike at *all* points. There isn't a weak clause to leave a loophole for weakness of construction. Our guarantee is strongest because years of the most rigid usage have proved Higgins Quality Springs equal in every *section* to all demands.

### This Alone Should Show You Where To Obtain Greatest Value

We *know* Higgins Springs will stand up and render satisfactory service in the center where 90% of all spring breakage occurs for under our scientific form of center building all weakness has been done away with. Instead of a bolt and a hole which rob the spring of just so much support—instead of a hump, which stiffens the center and causes equally great breakage outside malleable that holds leaves together, we employ the *nib* form of retaining leaves securely in place.

This improved design grips centers safely in position—it possesses strength which bears the brunt of heaviest loads and hardest bumps and *allows* the "give" essential

to real riding comfort. We employ only best grade of motor car spring steel of special analysis—tempered in furnaces and quenching baths constructed especially for us. Subjected to most exacting tests for defects in elasticity, tensile strength and anti-fatigue properties before shipping. They are *proved* perfect.

Higgins Quality Springs are equipped with rebound clips. Leaves properly lubricated with special high grade spring leaf lubricant. They never squeak. They never rust. They never leave you in doubt as to their dependability. Safe springs to buy—to use. Immediate shipments.

**Ask Your Supply House and be sure to send for prices and Catalog C-1917, showing 500 different styles—also proposition which is certain to stimulate spring sales.**

Higgins Spring & Axle Co.  
 Dept. 310, Racine, Wis.

58 25 '17

# AMERICAN BLACKSMITH

A Practical Journal of Blacksmithing and Wagonmaking

BUFFALO  
N.Y., U.S.A.

SEPTEMBER, 1917

\$1.00 A YEAR  
10c. A COPY

## ROWE *SCREW and DRIVE* CALKS

AND

### THE HORSE SHOER

### ARE FRIENDS



#### BECAUSE—

HORSE SHOERS only sell ROWE CALKS. No retail stores, no catalog houses, no selling direct to the consumer.

#### BECAUSE—

ROWE CALKS represent highest quality. Note the welded Tool Steel Center.



#### BECAUSE—

CONSUMERS will call for advertised calks and ROWE CALKS are the best advertised calks.

#### BECAUSE—

UNITED PROFIT-SHARING COUPONS, the most useful coupons printed, are packed with ROWE CALKS only, and in every carton.

## THE ROWE CALK COMPANY PLANTSVILLE, CONN.



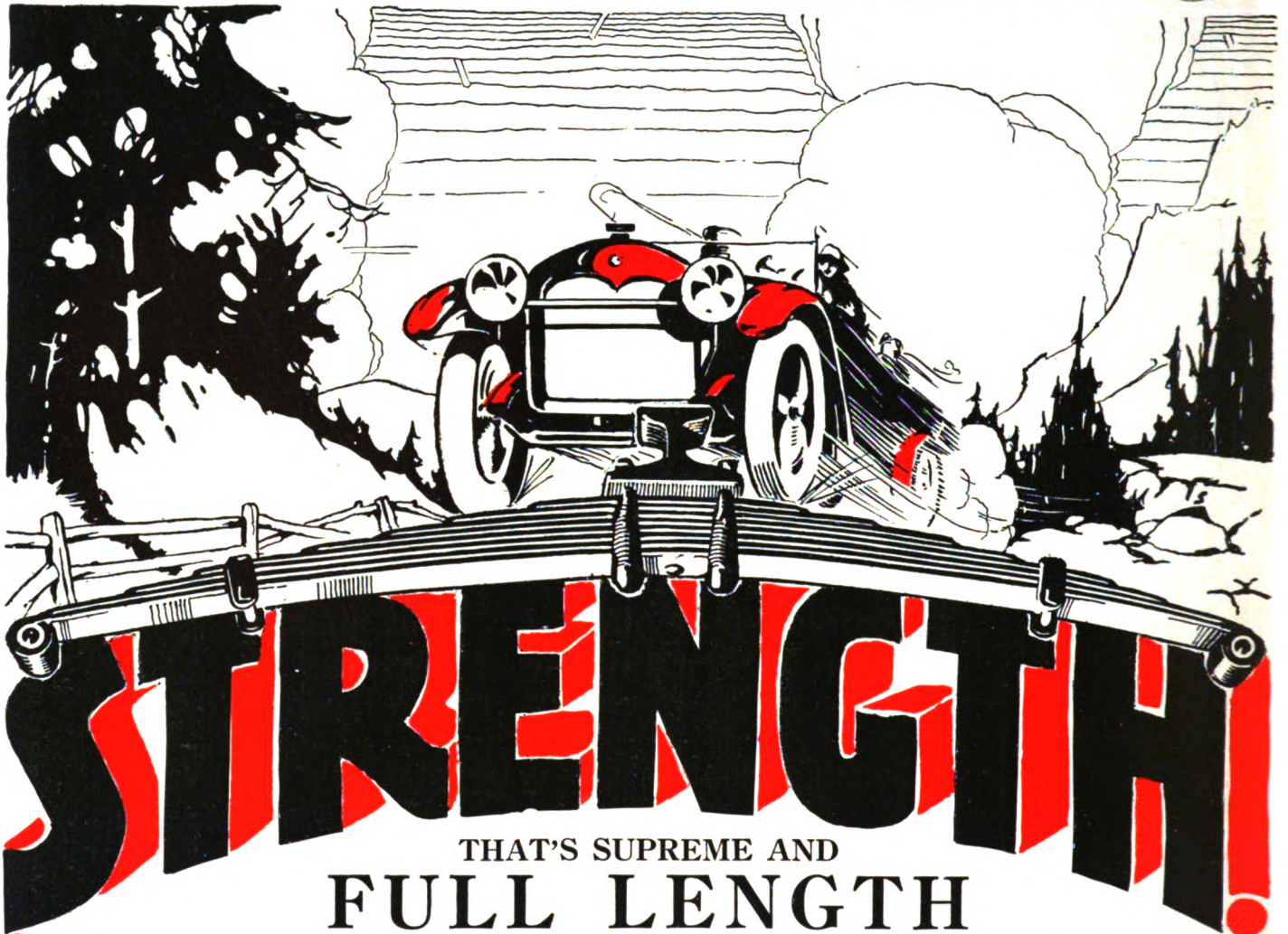

## THAT'S SUPREME AND FULL LENGTH

FOR years manufacturers have been striving to overcome center spring breakage. The hole for bolts had to go. It was a weak spot. Numerous methods have been devised—but at best they simply shifted the breaking point to another place. Take, for example, the hump construction. It *does* eliminate *exact* center breakage. But at the same time causes as great breakage *outside* of the malleable which holds the leaves together. So in correcting one evil it has invented *another*.

### Higgins Quality Springs

FOR REPLACEMENT

really accomplish what others have merely attempted. Through a new form of *nib* center construction center breakage has actually been reduced to an amazing minimum and this without expense of strength at any section of the spring. There is *no* center bolt—no hole—no metal dug out to lessen resistance. No hump to stiffen resiliency or transfer breakage to other parts. But strength that's *supreme and full length*—a "give" and "come back" which resists and absorbs shocks, promoting utmost riding comfort and guaranteeing spring dependability. Strongest where greatest stress is brought to bear—and sufficiently sturdy at *every* point to withstand hardest service.

A special high grade leaf lubricant is inserted between each leaf before spring is assembled for shipping—preventing squeaks and giving free, easy play that lengthens

tire life. No extra clips required—use those taken from old springs. Our confidence—our *certainly* that Higgins Quality Springs will make good in the *extreme* is shown in the fact that

#### The Same Guarantee Covers Every Point.

The most liberal guarantee—simply because there is less likelihood of breakage. You want spring safety—you want riding ease with it. Be sure you get *both* by demanding Higgins.

#### Ask Your Dealer.

He can supply Higgins Quality Springs designed especially for your car. If he refuses write us direct.

Higgins Spring & Axle Co., Dept. 410, Racine, Wis.

**Dealers:** Investigate our proposition. It is a hundred-per-center as a trade developer—because it affords motorists means of obtaining spring service and satisfaction they've always wanted. Write for Discounts and Big Catalog C-1917, listing 500 different designs.



# Don't Call Your Helper Down

because he makes a poor weld or spoils a piece of work when he is not at fault.

Investigate your coal pile—see if the trouble isn't there. Break open a piece. Notice the tiny streaks of brown or yellow between the layers—that's SULPHUR, the deadliest enemy of the smith shop.

You cannot afford to use anything but the best coal, with the price of metals mounting sky-high. You *must* use coal that will insure good welds and reduce the chances of loss on this account to a minimum. And means

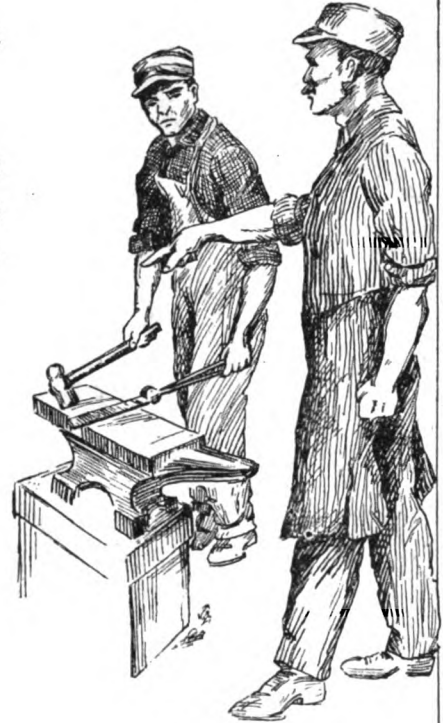

## *Webster Selected Smithing Coal*

A pure, heat-giving, coal—free from sulphur, dirt, slate and all other impurities that make good work an impossibility.

Write for your copy of *Forge Fire Facts No. 2* before the edition is exhausted—it will not only help you solve your coal problem, but is brimming over with handy forge-fire kinks that you should know.

**Pennsylvania Coal & Coke Corporation,**  
Whitehall Building, New York City, N. Y.



No. 228-E Forge—32x44 in. hearth. Suitable for practically all general blacksmithing work.

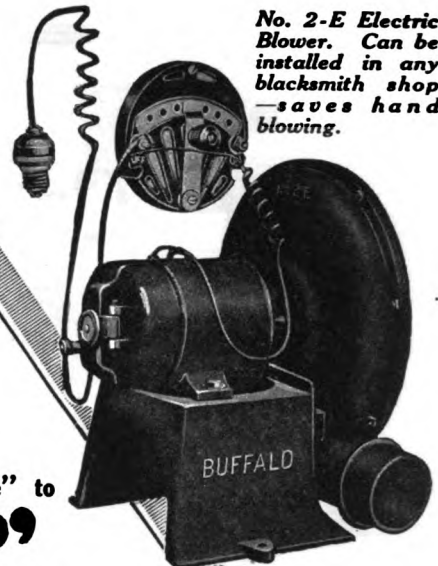

No. 2-E Electric Blower. Can be installed in any blacksmith shop—saves hand blowing.

Forty years of experience and knowledge of Blacksmith Shop requirements has placed Buffalo Tools so far ahead of any others, that once you use them you'll say "good-bye" to the other kind.

# “Buffalo”

## Blacksmith Tools

are first of all—dependable. They will stand up under continuous service—and hard service too.

They are constructed of good material, and by skilled workman.

These are facts you should keep in mind when buying Blacksmith Shop Equipment.

We'll be glad to mail you a copy of Catalog 179-1.

Buffalo  
Forge  
Company  
Buffalo, N. Y.

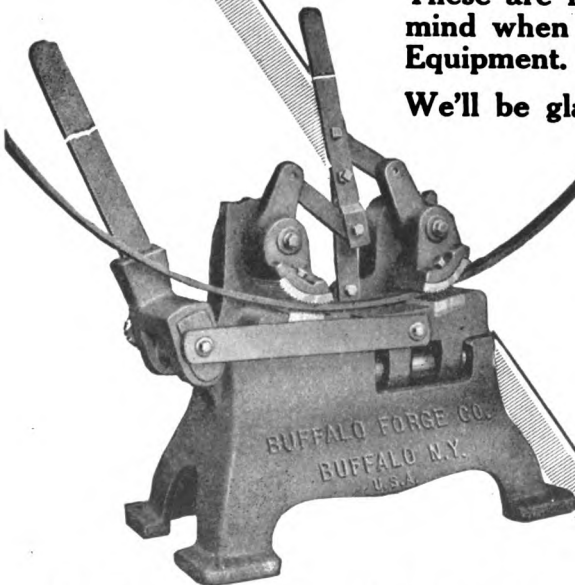

“BANNER” Tire Upsetter. Capable of setting tires up to 4' x 1".

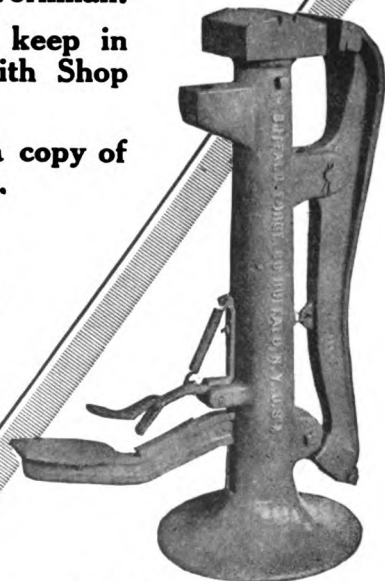

“SHOEMAKER” Vice. Saves time and labor on turning heels on shoes, hot filing, etc. Head 5 1/2" square—bevel on both sides. Leaves operator's hands free.



# PHOENIX

Horse and Mule Shoes  
are used by most Good  
Shoers—because of  
their better material—  
are easier to fit and  
more uniform than the  
ordinary run of shoes

## BULLDOG

Toe Calks are much  
better than the old-  
fashioned kind—"Take  
hold and never let go."

PHOENIX HORSE SHOE CO.



**No. 244. BODY AND SEATS**  
 Price, no seats....\$8.25 and up  
 Price with seats.... 11.95 and up

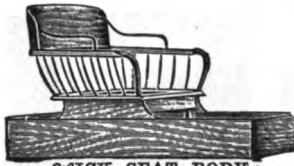

**STICK SEAT BODY**  
 \$8.58 and up

You can make \$5.00 in a few hours applying this Auto Roof Cover. Easy to apply. We furnish instructions.

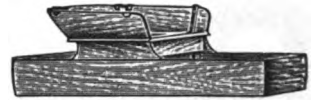

**PIANO BODY**  
 With seat.....\$6.07 and up  
 Without seat..... 4.87 and up



**ROUND CORNER SEAT**  
 Untrimmed \$3.00 and up  
 Trimmed .. 8.00 and up

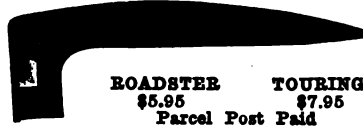

**ROADSTER TOURING**  
 \$5.95 \$7.95  
 Parcel Post Paid

Discount to dealers.  
 The time has come when it is to the Carriage Repair man's interest to do Auto Repairing, as well as Carriage and Wagon work. Get our 86-page Catalog, illustrating Tops, Wheels, Springs, Commercial Bodies, Trailers, Fenders, Seat Covers, Tires, etc., and giving dealers prices that will make you extra profits.



**STICK-TITE CURTAIN LIGHTS**  
 No sewing. Cost \$1.00 and up. Parcel Post Paid. You can make 100% profit.



**BUGGY GEARS**  
 Each .....\$12.50  
 With Wheels and Shafts \$26.90 and up

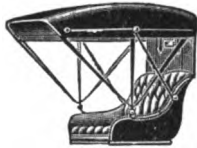

**AUTO SEATS—Top Seats**  
 Seat ..... \$ 3.56 and up  
 Cushion and back 7.43 and up  
 Top ..... 12.84 and up

Ford Front Springs, \$2.10



**BEADED CENTER NO BOLT HOLE**  
 Guaranteed not to break  
 Can furnish Springs for any make cars.



**TOP SETS**  
 Seat .....\$1.55 and up  
 Cushion ..... 1.88 and up  
 Back ..... 2.06 and up  
 Top ..... 9.94 and up



**DOUBLE TREES WITH SINGLE TREES**  
 Buggy and Surrey size.....Each 95c



30x8 Tires sell for \$12.00  
 Cost you \$10.00 delivered  
 Parcel Post; other sizes in proportion.

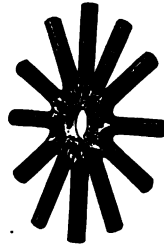

**SPIDER WHEELS**  
 Avoid delays in repairing broken Auto wheels. Auto Spider, \$2.20 and up. Buggy Spider \$1.90 and up.



**POLES**  
 In the white.....\$3.90  
 Painted ..... 4.90

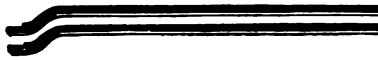

**BENT REACHES**  
 Assorted sizes .....10 for 75c



**STRAIGHT REACHES**  
 Assorted sizes .....20 for 75c



**POLES**  
 Buggy or Surrey Poles, Per bundle, ..\$7.50

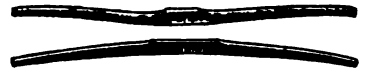

**AXLE BEDS**  
 Assorted sizes—drop ....14 for 60c  
 Assorted sizes—drop .... 8 for 60c

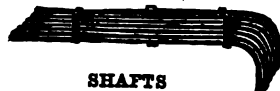

**SHAFTS**  
 Buggy size ..... \$8.90  
 Surrey size ..... 6.50



**SPRING BARS**  
 Assorted sizes .....14 for 75c

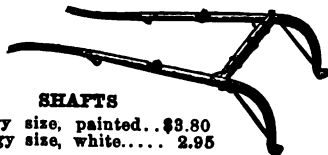

**SHAFTS**  
 Buggy size, painted..\$3.80  
 Buggy size, white.... 2.95



**LIGHT WHEELS**  
 With Steel Tire on \$7.80 and up.  
 With Rubber Tire on, \$16.80 and up.  
 We make all sizes.  
 Auto wheels with demountable rims, \$14.45.



**BUGGY AND WAGON AXLES**  
 \$1.95 and up  
 We carry all sizes

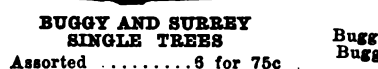

**BUGGY AND SURREY SINGLE TREES**  
 Assorted .....8 for 75c



**BUGGY SPOKES**  
 Per 100  
 1 in., Sar. Pat. ..\$1.80  
 1 1-16 in., Sar. Pat. ... 2.10  
 1 1-16 in., C. B. .... 2.25  
 1 7-16 in., Sar. Pat. ... 3.50  
 15-16 in., Warner Pat. 1.25



**ELLIPTIC CARRIAGE SPRINGS, \$1.10 and up**

Prices subject to change owing to unsettled conditions of raw material market. Better order now.

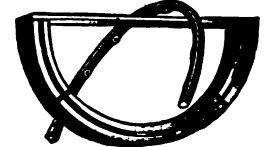

**RIMS**  
 We carry all sizes  
 Plain Rims...\$1.25 and up  
 Beveled Rims.. 1.50 and up  
 Bored and Rounded Rims \$1.80 and up  
 15 pieces bored and rounded rims, assorted sizes, for 75c



**WHEEL HEAD RIVETS**  
 Assorted sizes  
 8 lbs. for .....75c



**WOOD HUB REPAIR GRADE SPOKES**  
 Per Set  
 2 in., ..\$1.90  
 2 1-4 in., .. 2.10  
 2 3-8 in., .. 2.60  
 2 1-2 in., .. 2.90



Auto Tops Roadster, \$18.90 & up  
 Auto Tops, Touring, \$22.95 & up  
 Auto Seat Covers \$4.95 and up. Send for samples of Goods we use in our Tops & Seat Covers.

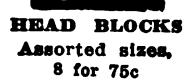

**HEAD BLOCKS**  
 Assorted sizes, 8 for 75c



**DASHES**  
 20 in. drill ....\$0.20  
 17 in. leather .. 1.20  
 26 in. leather .. 1.20  
 24 in. leather .. 2.60

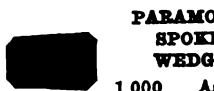

**PARAMOUNT SPOKE WEDGES**  
 1,000 Assorted size Spoke Wedges ..60c

Send for our Large Catalog on Carriage, Wagon and Auto Parts and learn how we do it  
 Our Freight Offer will interest you  
 Adjust your wants to the sizes and styles we furnish at the above prices and save money.  
**A WHEEL, TOP & HDWE. CO.,**  
 1100 Sycamore Street Cincinnati, Ohio

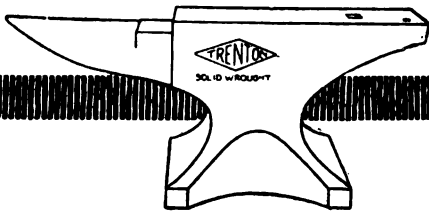

## The Smith's Best Friend— A GOOD ANVIL

A "Trenton" anvil was made one day  
In Columbus, Ohio, miles away.  
To be sent to a Smith who knew the way—  
To Progress—with a "Trenton" anvil.

It reached the end of its journey far,  
By horse and wagon and a slow freight car.  
To the waiting "Smith" who knew that he  
Had the best in an anvil there could be.

A nice clean forge, and a nice hot fire,  
All that a good anvil could desire.  
To make it at home; It had come to stay.  
For the other old anvil had worn away.

In the morning the Smith came at break of day  
His respects to the Trenton he must pay.  
This anvil had come to work, not to play,  
For it was a Trenton anvil.

As any wise Smith, he did the right thing,  
For when it's good natured an anvil will "Ring  
Like a Bell", and keep the Smith glad.  
No more broken work to make the Smith sad.

Then profit dear readers by what I have said,  
And order a Trenton 'ere you go to bed.  
You'll never be sorry, but always be gay  
For a Trenton anvil, in the end, *will pay.*  
E.H.V.

MANUFACTURERS OF THE FAMOUS "INDIAN  
CHIEF" SOLID BOX VISES.

## The Columbus Forge & Iron Co.

Columbus, Ohio.



## The MARTIN Rocking Fifth Wheel

is the only scientifically and correctly designed Fifth Wheel for connecting a Semi-trailer to a run-about or motor truck. It rocks with a fore and aft motion so that the load can adjust itself to the unevenness of the road and so that all six wheels can stay on the ground, but it holds the unit rigid on both sides, thus preventing any side sway or any tendency to tip over.

Substitutes for such a Fifth Wheel have been made, but they do not give satisfactory results. Moreover, any other Fifth Wheel designed to serve the same purpose and provided with a rocking movement to enable the load to adjust itself to rough road conditions infringes the basic patents for the MARTIN ROCKING FIFTH WHEEL.

This device enables you to transform a light run-about into a 1-ton or a 1½-ton truck; a larger touring car (with body removed and cab substituted for it) into a 2-ton or 3-ton truck; or to double or treble the capacity of any motor truck.

Any platform-type wagon can be converted into a motor Semi-trailer, using the MARTIN ROCKING FIFTH WHEEL for connection. Wagon manufacturers and blacksmiths can make good profits by making new Semi-trailers or turning old wagons into Semi-trailers.

Write us for full particulars.

MARTIN ROCKING FIFTH WHEEL CO.,  
244 MAIN STREET SPRINGFIELD, MASS.



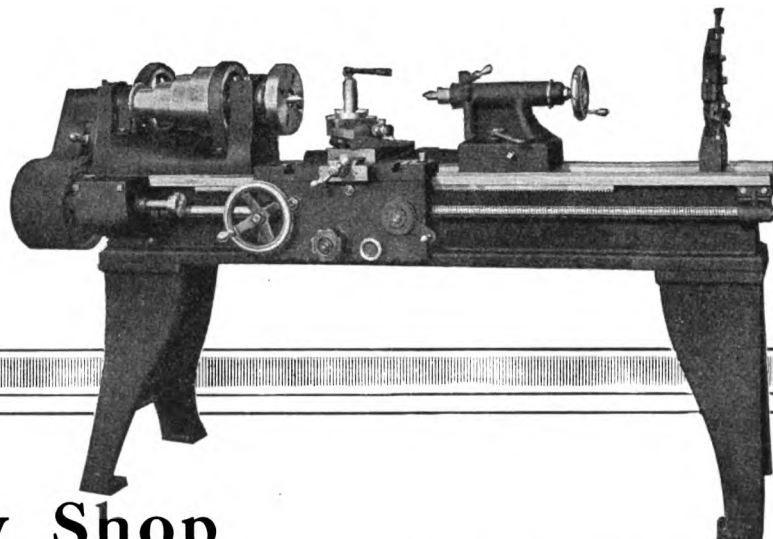

# Every Shop Needs This CANEDY-OTTO LATHE

Made by the same firm who for over 25 years have manufactured shop tools—noted for high quality and unexcelled workmanship.

**Canedy-Otto** 14", 16" and 18" screw cutting engine lathes are built for service. *Spindle* is made of 50 point Carbon Steel accurately ground runs in the best quality bronze bearings. *The Apron* is made for heavy duty. *Gear Box*—quick change type. *Complete Equipment* is furnished.

We make over 200 different styles and types of tools—to fill every requirement of blacksmiths, auto repair shops, machine shops, foundries and garages.

Most jobbers handle the **Canedy-Otto** line. If yours does not—write us and we will see that you are supplied.

*Catalogue No. 12 gladly sent on Request.*

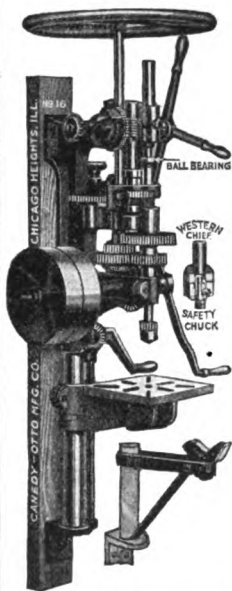

**No. 16 Drill**

The largest post drill made; drills from 0 to 1 1/2 in. holes. Has automatic self-feed and all the features of a high-grade machine shop floor drill.

**No. 8 One Fire Electric Blower**

Guaranteed to be superior to any blower on the market. Built for service.

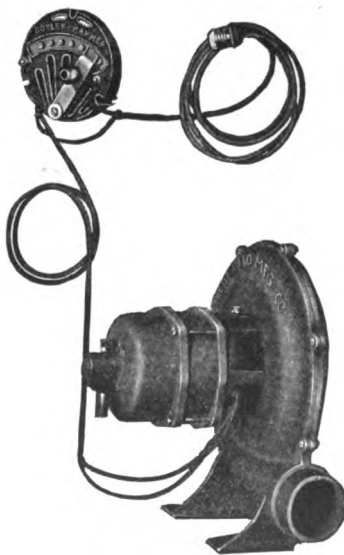

**No. 100 Royal Forge**

The most popular forge of today. Hearth 31 1/2 by 45 1/2 in. Capacity to heat 4 in. iron.

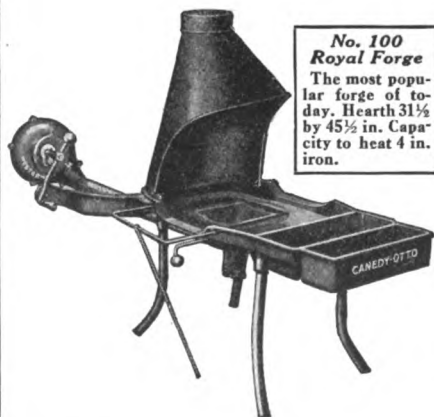

**No. 3 Grinder**

A well-machined and highly-finished grinder, made in four different sizes. Will take from smallest up to 20 in. wheels. Furnished with or without column.

**No. 36 Drill**

A 20 in. upright floor drill, equipped with back-gears, self-feed and automatic stop, very accurate and rapid in operating. Drills from 0 to 1 1/2 in. holes.



**CANEDY-OTTO MFG. CO.,**  
CHICAGO HEIGHTS, ILL., U. S. A.



# U O S

FROST SNOW

## UNITED STATES HORSE & MULE SHOES

ARE PERFECT ALL THROUGH AND EASY TO FIT

**A Trial Order Will Convince You**  
Carried in Stock By All Leading Jobbers

Write for our latest Catalog No. 16 illustrating our complete line of over 500 different patterns and sizes.

A Handsome Souvenir Watch Fob Given Away Free to All Blacksmiths and Horsemen on request.

Manufactured By

**United States Horse Shoe Co.**  
Erie, Pennsylvania

## Blacksmiths Make Big Money

### Fitting Wagons with Coil Spring Buffers

Almost every spring wagon that comes to your shop needs Victor Buffers. You can fit out these wagons with very little talk, and pocket a nice profit. You'll soon work up a good business on them.

## VICTOR Coil Spring BUFFERS

will double carrying capacity of carriage and wagon springs. Positively prevent breaking springs—save their cost in this way alone.



**SAVE**  
They Pay Their Cost in Repair Bills Saved.

Victor Coil Spring Buffers give light, easy riding; resilient spring for light loads; strong spring for heaviest loads—saving jarring and jolting.

## Victor Coil Spring Buffers

**For Sale by All Jobbers**

Order Victor Coil Spring Buffers from your Jobber at once. All sizes, to fit either elliptical or platform springs. Easily and quickly attached without bolts or straps. Never work loose. If your Jobber can't supply you, write us.

**Indianapolis Bolster Spring Co.**  
Dept. 513 Indianapolis, Ind.

# BOSS Snow Shoes

**Light and Extra Light Patterns**

**IS YOUR STOCK SUFFICIENT TO COVER YOUR NEEDS FOR THE COMING WINTER?**

**Bryden Horse Shoe Works**  
CATASAUQUA, PENNA.

Send for descriptive catalog.



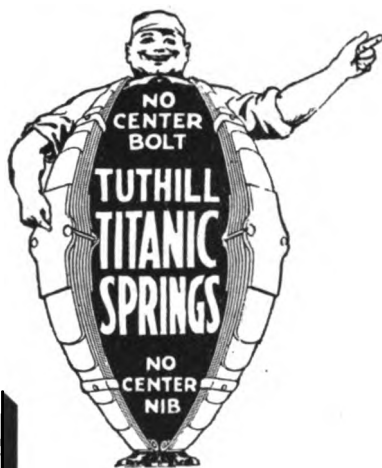

# No More Spring Fixing

*when you ride on*

***Tuthill Titanic Lubricated Springs.  
Guaranteed forever against center  
breakage—guaranteed at all points  
and in every respect for one year.***

**E**VERY time you break a spring it must be fixed—replaced in most cases. Do you know why it breaks and what causes it to do so? It's the *flaw* in the center, found in old type springs—the punching away of metal for a center bolt hole or punching in of a center nib that weakens the spring at the center and causes it to break.

## Tuthill Titanic Lubricated Springs

are free from weakening center bolts and center nibs. Instead Tuthills are **strongest at the center**. A **patented flawless arch** makes them practically *break-proof* at this point—the point where seven out of every ten breaks occur.

Tuthill Titans can be easily adapted to practically any type of axle construction *without extra expense*. A special Tuthill Titanic Front Spring for Fords is now made by us. It is **guaranteed** just like all other Tuthill Titans.

Ask your dealer for Tuthill Titans—if you cannot get them from him, let us know. Send for our valuable spring book — it is free.

### Dealers!

Tuthill Titans are used for more spring replacements than all other types put together. That means a big business in springs. If you are not a Tuthill dealer, write for our proposition, name of nearest distributor and 1917 Price List—the most complete list of spring replacements ever published.

### TUTHILL SPRING COMPANY

*Established 1880*

760 Polk Street

Chicago, Illinois

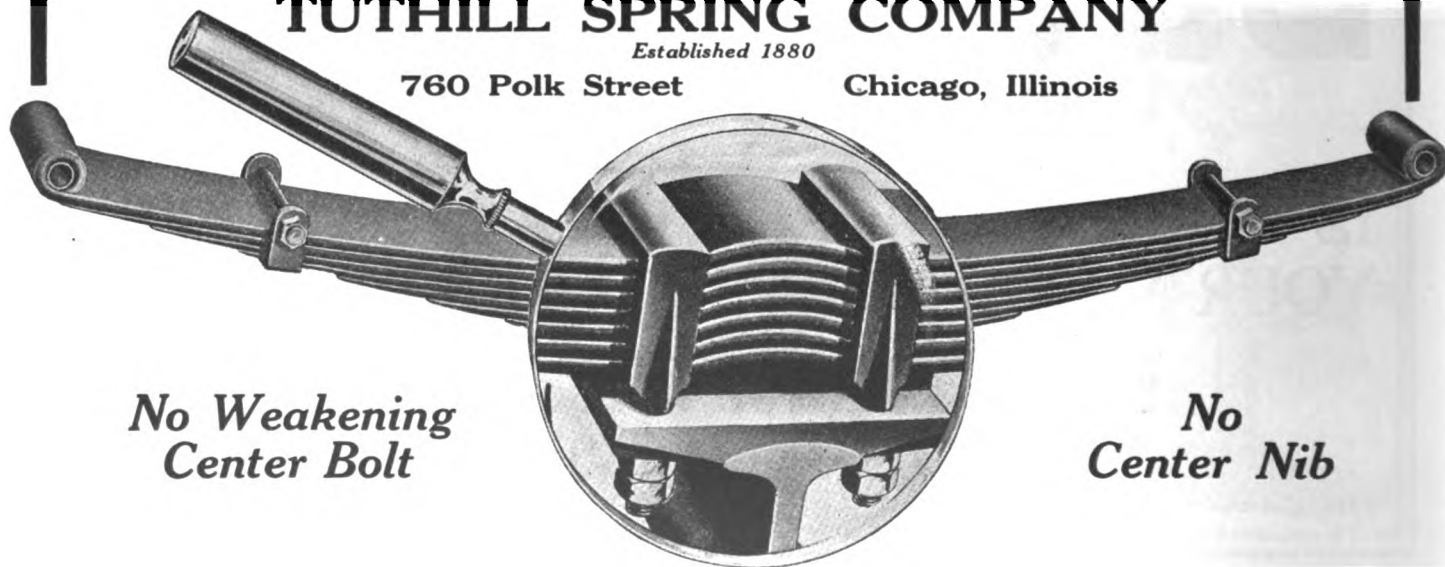

*No Weakening  
Center Bolt*

*No  
Center Nib*



The incomparable 400 Blower, the one great Heirloom that will be handed down from one generation to the other. Ask what the owners say. MADE WITH BALL BEARINGS ONLY.

**OVER 750,000 CHAMPION 400 BLOWERS IN USE.**

The 400 is the Blower that has Revolutionized the World in making Hand Blast.

**Tuyere Iron That Makes a Whirlwind Blast**

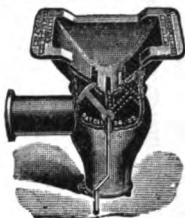

The "Whirlwind" Blast Anti-Clinker, Heavy Nest Tuyere Iron produces a circular, rotary whirlwind blast and concentrates the heat in the tuyere nest, not permitting it to blow up and out of the chimney, therefore makes a hotter fire and heats the iron one third quicker; saving much coal.

The No. 400 "Whirlwind" Blast, Anti-Clinker, Heavy Nest Tuyere Iron is furnished with all 400 Blowers WITHOUT EXTRA COST.

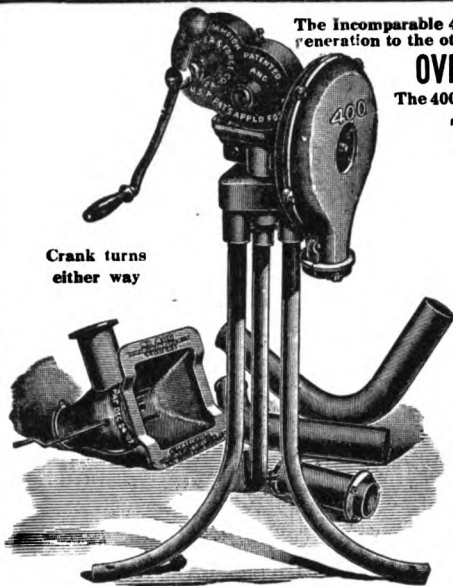

Crank turns either way

No. 400



No. 408. Steel Blacksmiths' Forge

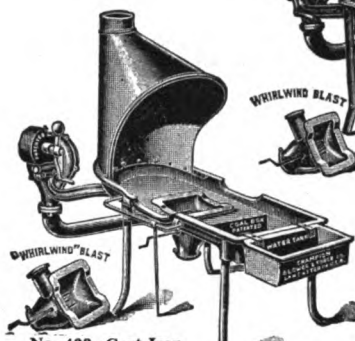

No. 433. Cast-Iron Blacksmiths' Forge

NO. 1 CHAMPION COLUMN GRINDER.

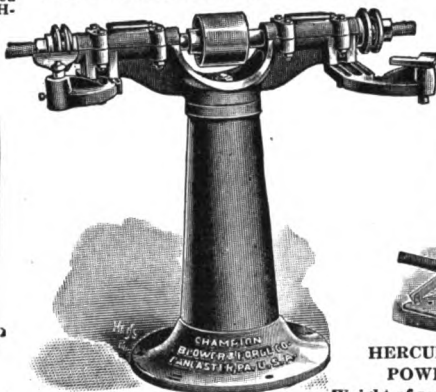

No. 1 Champion Upright Column Grinder. Capacity two 18 by 3 inch wheels.



HERCULES PATENTED POWER HAMMER

Weight of ram, 65 pounds. The Power Hammer with the flexibility in stroke of a Hammer in a Mechanic's hand.

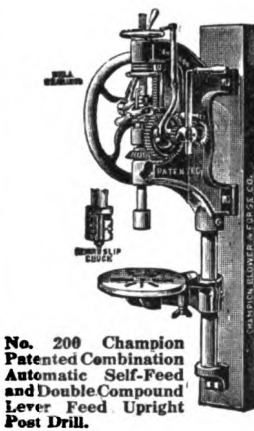

No. 200 Champion Patented Combination Automatic Self-Feed and Double Compound Lever Feed Upright Post Drill.

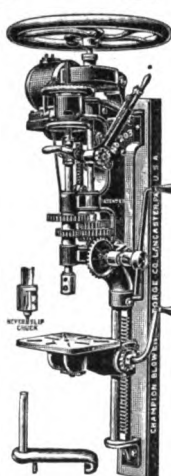

No. 203. Self-Feed and Double Compound Lever Feed, Electrically Driven Post Drill.

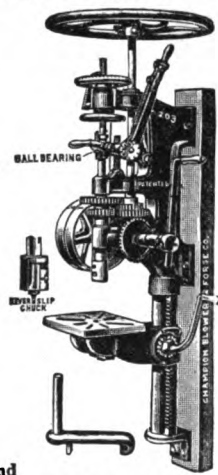

No. 203. Self-Feed and Double Compound Lever Feed Drill.

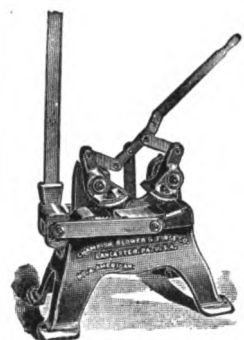

No. 4. AMERICAN TIRE AND AXLE SHRINKER. Will shrink up to 4x1-inch round edge tire, and axle up to 1 1/4 in.

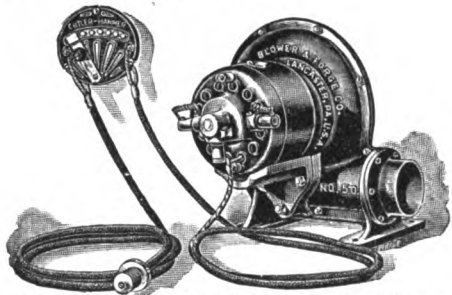

No. 50. Champion One-Fire Variable Speed Electric Blacksmith Blower with a Universal Motor for Both Direct and Alternating Current, either 110 or 220 volts, with Detached Rheostat for six speeds, and Steel Pressure Blower Case, for all kinds of general Blacksmith work.

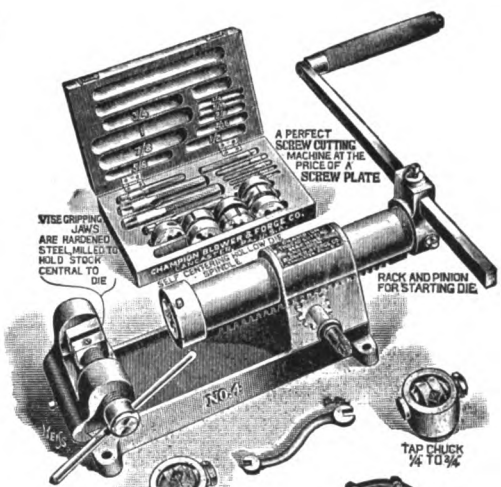

THE CHAMPION THREAD-CUTTING MACHINE Made in four styles. Cutting from 1/4 to 3/4, or 1/2 to 1 inch. With dies only, or with dies, taps and tap chuck.

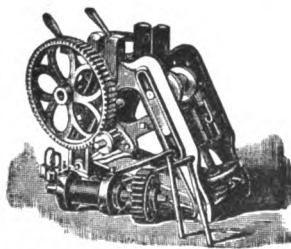

THE CHAMPION "COLUMBIAN" TIRE BENDER. Made in three sizes.



SCREW PLATES IN FOUR STYLES, CUTTING UP TO 1 1/2 IN. Before purchasing a Hand Blower, Forge, Drill Press, Tire Bender, Tire Shrinker, Screw Plate, Power and Electric Blower, Hammer, Punch, or Shears, write for our free catalogue, which always shows the greatest variety of improved Blacksmith tools built under one control in the world.

THE CHAMPION BLOWER AND FORGE CO., Lancaster, Pa., U. S. A.

FAN BLOWERS MADE IN SIZES UP TO 64 INCHES IN HEIGHT



## THE BRADLEY BALL-BEARING Carriage Coupler

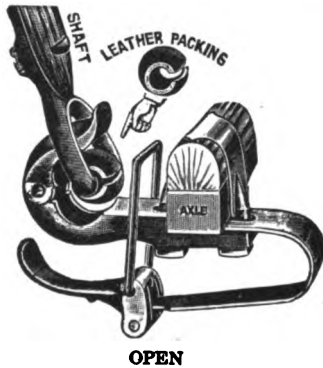

The Bradley Ball-Bearing Carriage Coupler is made entirely of steel.

Every part, except the flat spring and the loop, are steel forgings made from the bar under mighty drop hammers.

The flat spring is cut from high grade, crucible sheet steel, formed when hot and then carefully tempered and tested.

The loop is of special stiff steel wire.

Not a piece of malleable iron or other inferior or unreliable material is used.

The leather packings are in one piece and moulded to shape in machines made especially for this work.

The retaining rings keep the leather packings in place and are indispensable where shafts and poles are frequently removed.

Placing the loop over the end of the cap and drawing the thumb lever back against the flat spring closes the coupler, locks it and takes up any wear of the leather packing.

An absolutely non-rattling, quick-shifting carriage coupler.

*Circulars and prices upon request.*

**C. C. BRADLEY & SON**  
SYRACUSE, N. Y.

# YOU

OWE IT TO YOURSELF TO USE  
THE BEST TOOLS TO ASSIST  
IN YOUR WORK

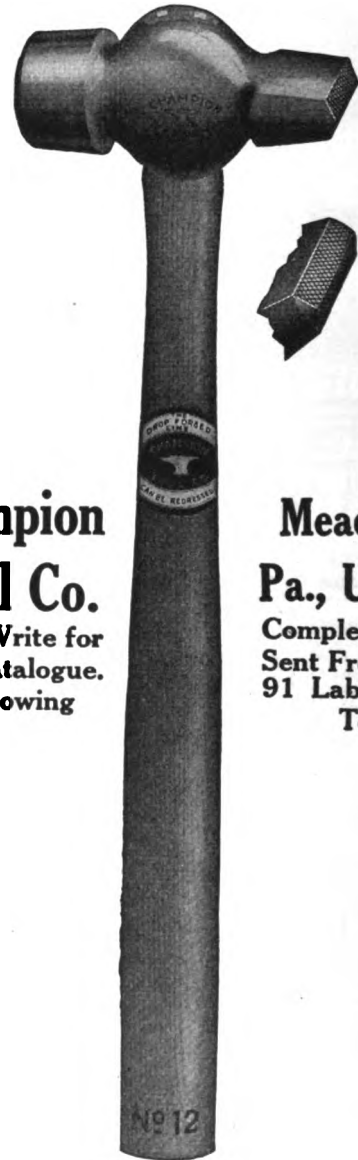

**Champion  
Tool Co.**

Write for  
Catalogue.  
Showing

**Meadville,  
Pa., U. S. A.**  
Complete  
Sent Free.  
91 Labor Saving  
Tools

**No. 12 Electric Sharpening Hammer**

Weights  $1\frac{1}{4}$  to 3 lbs.

Corrugated Pein prevents shoe slipping  
from anvil, making every blow count.

**Drop Forged  
Correctly Tempered  
Swings Just Right**



### Conkey's FLY KNOCKER

Chases the fly. Relieves horses of this tormenting pest. Makes shoeing quicker, better, easier and safer. You can sell FLY KNOCKER to every farmer, dairyman and stockman. Write for dealers' prices.

THE G. E. CONKEY CO.

Qt. 35c Cleveland, Ohio. Gal. \$1.00

### Edwards Shears

For twenty years the Two Leading Low Priced Shears in the U. S., representing the Greatest Value for the Least Money.

No. 5, weighs 200 lbs., cuts 4 1/4 inch soft steel  
No. 10, weighs 430 lbs., cuts 4 3/4 inch soft steel  
At their price you should have had one long ago. Order one from the first iron man that calls on you. They All Sell Them.

Write for descriptive circular and prices.

C. D. EDWARDS



Albert Lea, Minn.



**THE IMPROVED EASY HOOF TRIMMER**  
Will cut a hoof easier, quicker and better than any tool you have ever had. Weight 2 1/2 pounds, opening, 2 inches, cuts one inch. Thousands of shoers are using the EASY HOOF TRIMMER with great satisfaction.

SEND A DOLLAR TODAY

Delivered to any part of the U. S. by Parcels Post.

Muncie Wheel Company, Muncie, Ind., U.S.A.

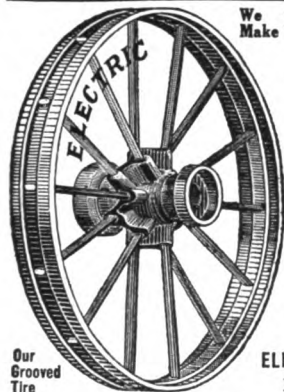

We Make STEEL WHEELS

To Fit Any Axle  
Plain or Grooved  
Tire

Steel or  
Hickory Axles  
Any Size  
A Full Line of  
Wood and Steel  
Farm Trucks

With Steel or  
Wood Wheels  
Write for Large  
Catalog and  
Prices

ELECTRIC WHEEL CO.

Box A, Quincy, Ill.

Our Grooved Tire

### "MARVEL" Forge Blowers

This cut shows you the RING OIL BEARING design and construction of the motors used in our "ONE FIRE" \$28.00 MARVEL and our No. 23 MARVEL \$25.00 Blowers, the windings being different.

Note the large oil rings which revolve with the CASE HARDENED, shaft keeping it running in a perfect bath of oil on the bearings. Perfect lubrication means long life.

Shipped on 30 days' trial through your dealer.

Electric Blower Co.  
Boston, Mass.

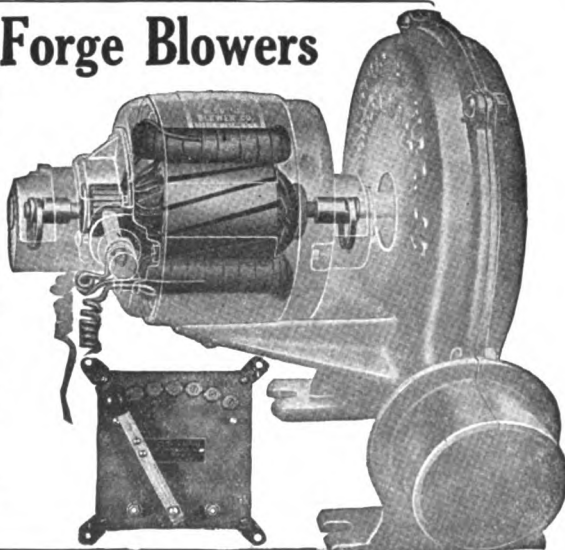

### INDEX TO ADVERTISERS

A kron-Selle Company	47
American Welding Co.	48
Anti-Borax Compound Company, The	50
A. Wheel, Top & Hardware Company	6
Barcus Mfg. Company	50
Beals, McCarthy & Rogers	44
Bermo Supply Co.	46
Bradley & Son, C. C.	12
Brooks Machine Company	44
Bryden Horse Shoe Company	9
Buffalo Forge Company	4
Bush Motor Co.	13
Butterfield & Company	48
Campbell Iron Company	44
Canedy-Otto Mfg. Company	8
Capwell Horse Nail Company	52
Champion Blower & Forge Company	11
Champion Tool Company	12
Chandlee & Chandlee	44
Chase & Co., L. C.	52
Coleman, Watson E.	44
Columbian Hardware Co.	37
Columbus Anvil & Forging Company	48
Columbus Forge & Iron Company	7
Conkey, G. E.	13
Cortland Welding Compound Company	40
Crandal, Stone & Company	52
Cray Brothers	38
Crescent Machine Company	37
Cummings & Emerson	44
Cutter Company, George A.	48
Diamond Calk Horse Shoe Company	51
Economy Welding Machine Co.	13
Edwards, C. D.	13
Electric Blower Company	13
Electric Wheel Co.	13
Empire Mfg. Company	42
Evans & Company, Victor J.	44
Evieth-Lindsay Company The	14
Felton Sibley & Company, The	14
Firestone Tire & Rubber Company	41
Foos Gas Engine Company	52
Franklin Steel Works	49
Galloway Company, William	46
General Welding Company	39
Giant Grip Horse Shoe Co.	45
Greenfield Tap & Die Corporation	38
Greer College of Motoring The	38
Gwilliam Co.	46
Hart Mfg. Company	47
Harvey Spring & Forging Company	43
Havana Metal Wheel Co.	44
Hay-Budden Mfg. Company	52
Heller Brothers Company	42
Henderson Willis Welding & Cutting Co.	52
Higgins Spring & Axle Co.	2
Imperial Brass Mfg. Company	41
Indianapolis Bolster Spring Company	9
Jenkins Vulcan Spring Co.	40
Jenner, Herbert	44

Linde Air Products Co., The	37
Little Giant Punch & Shear Company	48
Lowe Mfg. Company	48
L. S. P. Calking Machine Company	44
Macgowan & Finigan	42
Martin Rocking Fifth Wheel Co.	7
Mayer Bros. Company	49
Miller Charles E.	43
Milton Mfg. Company	47
Modern Engineering Company	39
Montgomery & Co., Inc.	42
Mowers Mfg. Co.	52
Muncie Wheel Company	13
National Rubber & Specialties Co.	47
Nebraska Auto School	43
Newton Remedy Company	13
Nicholson File Company	14
Norton Company	40
Parker, C. L.	44
Parks Ball Bearing Machine Company	49
Pennsylvania Coal & Coke Corporation	3
Phoenix Horseshoe Company	5
Plymouth Foundry & Machine Company	43
Porter, H. K.	44
Prentiss Vise Company	44
Randolph & Company	44
Raymond Mfg. Company	49
Rowe Calk Company	1
Sebastian Lathe Co.	42
Sidney Tool Co.	49
Simonsen Iron Works	47
Star Mfg. Company	40
Tuthill Spring Co.	10
Union Horse Nail Company	50
United States Horse Shoe Company	9
Vulcan Process Co.	38
Wells, F. E. & Son Company	39
West Tire Setter Company	50
Whisler Mfg. Co.	46
Witte Engine Works	46
Young W. F.	42

### Driver Agents Wanted

Drive and demonstrate the Bush Car. Pay for it out of your commissions on sales. My agents are making money. Shipments are prompt. Bush Cars guaranteed or money back 1918 models now ready to write at once for my 48-page catalog and all particulars. Address J. H. Bush, Pres. Dept. 9AB BUSH MOTOR COMPANY, Bush Temple, Chicago, Illinois

### DEATH TO HEAVES! NEWTON'S

STANDARD REMEDY HEAVE, COUGH, DISTEMPER AND INDIGESTION CURE. Cures Heaves by correcting the cause - Indigestion. Prevents Colic, Staggers, etc. Best Conditioner and Worm Expeller. Used by Veterinarians for 30 years. The first or second \$1.00 can cures heaves. The third can is guaranteed to cure or money refunded. \$1.00 per can at dealers' or sent direct prepaid. Booklet free. THE NEWTON REMEDY COMPANY, Toledo, Ohio.

### HAVE YOU ANY FRIENDS

in the smithing craft whose good will you especially esteem? There is no better way of showing them your friendship than by a small gift; there is no gift which such a friend would appreciate more than a year's subscription to The American Blacksmith. It will remind him of you constantly for an entire year and furnish him with interesting, valuable reading which he will greatly like. If you have any friends who are not subscribers, write us for terms of subscriptions for them.

AMERICAN BLACKSMITH CO.  
P. O. Box 974, BUFFALO, N. Y., U.S.A.

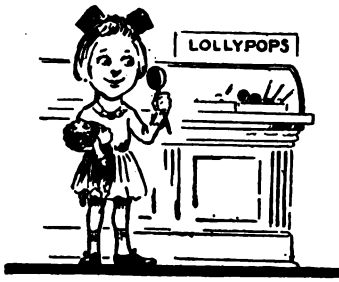

### "F-S" Products give lasting satisfaction.

You'll never hear a complaint if you use "F-S" Quality Coach, Carriage and Automobile Varnishes and Japans. Their reputation for satisfactory results has been gained through half-a-century's adherence to the very highest standards.

**FELTON, SIBLEY & CO., Inc.**  
*Manufacturers of Colors, Paints and Varnishes since 1863*  
No. 136-140 N. 4th St., PHILADELPHIA

(141)

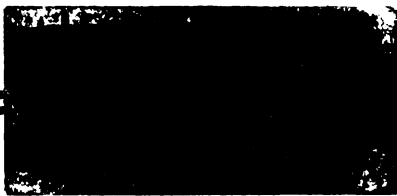

### A Big Profit Made on this Job

A new aluminum crank case like the above would cost over \$100. This one was welded as good as new with a *Torit Outfit* at a cost to the welder of only \$3.20—and the welder made a big profit.

There are big money making opportunities in the welding business for shop owners. Broken parts of implements, tractors, autos and other machinery—formerly thrown in the scrap heap can be welded and made as strong as new, in a few minutes.

# TORIT

## 16300°

Welding, Cutting and carbon removing equipment. Extremely simple, safe and reliable. Though reasonable in price, are made of only the finest material by skilled workmen. Ideal apparatus for either the small or large shops.

*Write for Catalogue*  
Decide *now* to investigate possibilities in the welding business by writing for catalogue, describing *Torit Equipment*, gladly sent on request.

**The Evleth-Lindsay Company**  
St. Paul, Minn.

A full line of supplies for welders carried and sold at reasonable prices.

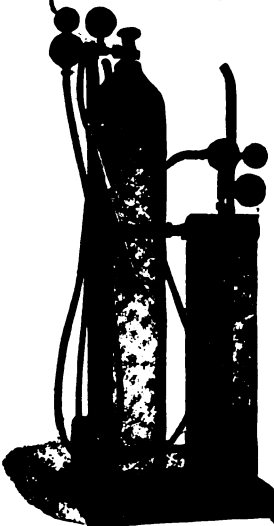

## Save Time and Money

The experienced blacksmith, who is extra hard to please in Rasps, will stop short of nothing but the best. He will always

### Use NICHOLSON RASPS



*See that this brand is on every rasp you buy*

50 years' experience, as well as special study of blacksmiths' needs, enter into the making of each of these rasps.

Every NICHOLSON rasp is rigidly inspected for temper and cutting qualities before it is wrapped in our rust-proof paper, boxed and sealed.

**SOLD BY LEADING DEALERS**  
*Catalog Sent Free on Request*

NEW 18-inch Slim Horse Rasp

**Nicholson File Co.**  
PROVIDENCE, R. I.





# Find Out What Great Profits a Crescent Woodworker Would Make for You

Have you ever seriously considered the extra business you could handle if you had a Crescent Woodworker.

For instance this is the automobile time of the year—if you had a Crescent that would mean many chances to build new bodies or to convert old cars into motor trucks.

This is also the time when farmers are ready to buy hay racks, carts, farm wagons, plow handles, and many other articles you could make in your spare time at good profits if you had the help of a Crescent.

Let us tell you about this special design which has been developed solely for the Blacksmith-Carriage shop. Let us explain our system of attachments whereby you are furnished with only the essential machines at the beginning and can select your attachments as you are sure you need them.

This is information you would be glad to receive—and you would also find the 1918 Crescent catalog a great help. Why not write your letter now?

**Crescent Machine Company,**  
245 Main St.,  
Leetonia, Ohio.

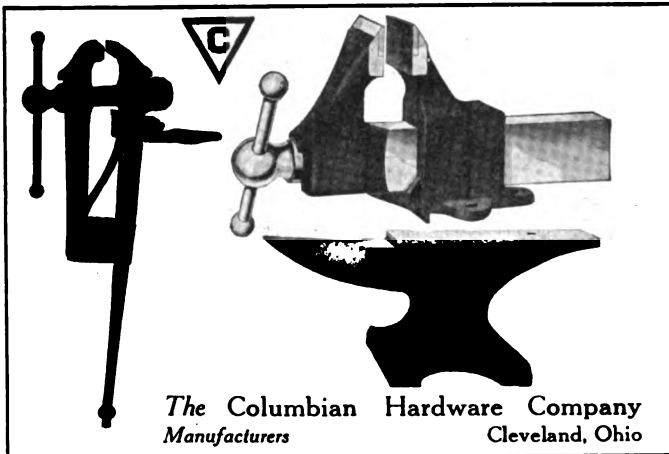
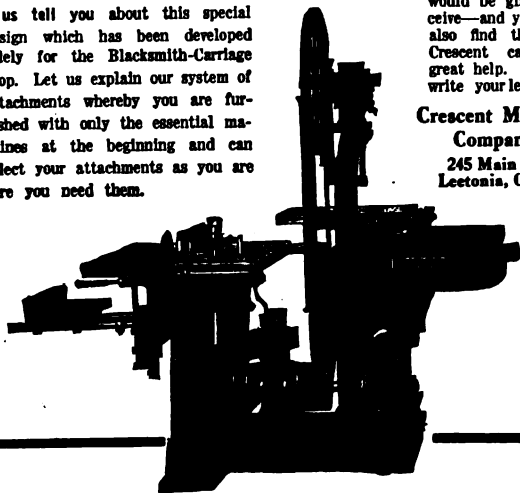

The Columbian Hardware Company  
Manufacturers  
Cleveland, Ohio

## NEED HELP?

Our Subscriber's Service Department is ready to help you with the jobs that puzzle—buying of supplies—with your printing, shop plans and bookkeeping—with the thousand and one other things that are always coming up to bother you. When in doubt ask the Service Dept. It's their business to help you.

**THE AMERICAN BLACKSMITH,**

Box 974, :: BUFFALO, N. Y., U. S. A.

# LINDE OXYGEN

From Coast to Coast 58 Producing Plants and Distributing Stations provide an unlimited supply of Linde Oxygen for users everywhere.

LINDE SERVICE means no investment except for oxygen actually received—no expensive overhead or upkeep charges.

Linde Oxygen may be obtained from any of the following Linde Plants and Distributing Stations where a large supply of charged 100 and 200 cu. ft. cylinders is kept on hand constantly to insure immediate shipments.

Mail or telephone your order to THE LINDE AIR PRODUCTS CO., at the nearest point. Shipments will be made on day order is received.

### Distributing Stations

- Alabama**  
Birmingham (Plant)  
10th Ave. & 28th St.
- Colorado**  
Denver  
1550 Glenarm St.
- District of Columbia**  
Washington  
9th & Maryland Ave., S. W.
- Georgia**  
Atlanta (Plant)  
Plyant St. & Southern R. R.
- Savannah**  
Ogeechee Canal, So. of Bay St.
- Illinois**  
Chicago (Plant)  
8633 Wall St.  
Chicago (North Side)  
118 Austin Ave.  
East St. Louis  
6th & Walnut Ave.
- Indiana**  
East Chicago (Plant)  
Fort Wayne  
414 E. Columbia St.  
Indianapolis (Plant)  
2819 Roosevelt Ave.
- Iowa**  
Davenport  
118 Harrison Street.  
Des Moines  
117 W. 5th Street
- Kansas**  
Wichita  
Rock Island Ave. & 2nd St.
- Kentucky**  
Louisville  
126 E. Main St.
- Louisiana**  
New Orleans  
861 Fulton St.
- Maryland**  
Baltimore (Plant)  
25th & Montebello Ave.
- Massachusetts**  
Cambridge  
25 Waverly St.  
Springfield  
Napier St.  
Worcester (Plant)  
961 Southbridge St.
- Michigan**  
Detroit (Plant)  
St. Aubin Ave. & Newton St.  
Grand Rapids  
Pearl St. by the Bridge
- Minnesota**  
Duluth  
Seventh Ave. West  
Minneapolis (Plant)  
1809 E. Hennepin Ave.
- Missouri**  
North Kansas City (Plant)  
14th & Charlotte St.  
St. Louis (Plant)  
4218 Forest Park Blvd.
- Nebraska**  
Omaha  
1007 Jones St.
- New Jersey**  
Elizabeth  
Linden Ave.  
Newark  
854 Plane St.
- New York**  
Albany  
Montgomery & Colonie Sts.  
Brooklyn (Plant)  
475 Driggs Ave  
Buffalo (Plant)  
155 to 188 Chandler St.  
New York City  
217 W. 29th St.  
New York City (Bronx)  
3168 Park Ave.  
Utica (Plant)  
Walnut & Schuyler Sts.
- Ohio**  
Cleveland (Plant)  
E. 73rd & Bitten Ave.  
Cincinnati (Plant)  
Stanton & Mellish Aves.  
Columbus  
310 Dublin Ave.  
Dayton  
521 E. First St.  
Toledo  
414 S. Erie St.
- Oklahoma**  
Oklahoma City  
27 E. Grand Ave.  
Tulsa  
1 North Boulder St.
- Pennsylvania**  
Erie  
1502 Sassafras St.  
Norristown (Plant)  
No. Philadelphia (Plant)  
18th & Cambria Sts.  
Pittsburgh  
16th & Pike Sts.  
Trafford (Plant)
- Tennessee**  
Chattanooga  
212 to 238 King St.  
Memphis  
203 Washington St.
- Wisconsin**  
Milwaukee (Plant)  
36th St. & National Ave.

### PACIFIC COAST

- California**  
Emeryville, Oakland (Plant)  
Los Angeles (Plant)  
1405 Mission Road
- Oregon**  
Portland  
15th & Hoyt Sts.
- Utah**  
Salt Lake City  
112 W. Second St. South
- Washington**  
Seattle  
530 First Ave. South
- TEXAS**  
Dallas (Plant)  
Harwood & Coombs St.  
Houston  
Cedar & Baker Sts.  
San Antonio  
512 Dolorosa St.

## The Linde Air Products Company

Largest Producers of Pure Oxygen in America

Forty-Second St. Building, NEW YORK

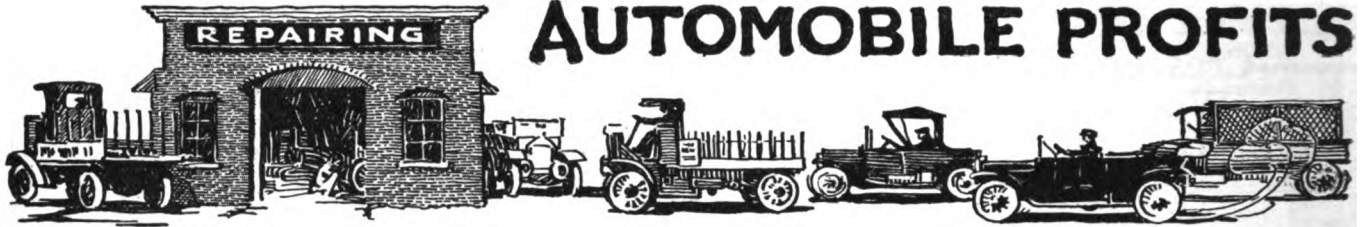

# AUTOMOBILE PROFITS

**T**HERE are big opportunities in the automobile repair field for the general smith. If you want to make the best of these big opportunities read this department every month.—It contains the announcements of advertisers who have real automobile profit suggestions. Look here for your equipment, supplies and accessories.—Turn to this department for ideas, suggestions and hints. It means more money for you—more Automobile Profits.

WHEN IN DOUBT ASK SUBSCRIBER'S SERVICE.

## Save The Pieces

If you are equipped with a  
**VULCAN  
OXY-ACETYLENE**  
Cutting and Welding Outfit

you can make repairs so strong, so quickly and so economically that it makes the outfit a big income producer. Ideal for burning carbon out of cylinders, a highly profitable business.

Be sure to get a VULCAN outfit—there is no other as good. Write for catalog A 4.

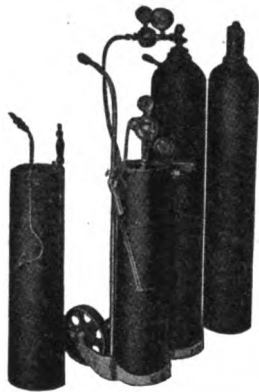

**VULCAN PROCESS CO.,** 2427 University Avenue, S. E.  
MINNEAPOLIS, MINN.

## CAPTURE THE BIG MONEY IN AUTO REPAIRING

MAKE SURE YOUR PREPARATION IS RIGHT

If you would make a real, lasting success of automobile work—if you would make your shop the leading auto fixing place in town—then come to the Greer School and get the right steer by actual first-hand methods. You have the general mechanical ability to learn in only a few weeks. But unless you are grounded with the right knowledge you will never be a first class Auto Smith.

Let us tell you about our great success—our 12 years experience in fitting men for the automobile game—and how our personal method of expert instruction gives you a grasp of the whole proposition you can obtain in no other way. Write for complete details at once.

**THE GREER COLLEGE OF MOTORING**

Greer Bldg.,  
1519-1521 Wabash Ave.,  
Chicago, Ill.

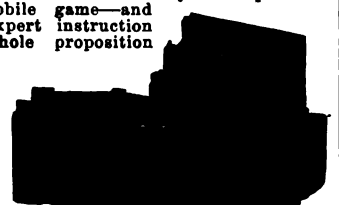

**FREE**

512  
Pages  
of  
Bargains

Post

Paid

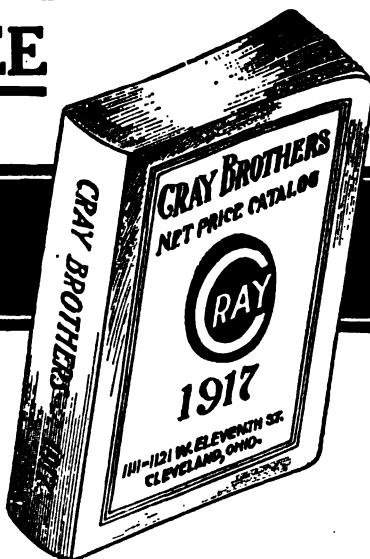

**FREE**

**WE WANT to SEND YOU THIS 512 PAGE MONEY MAKING BOOK**

It is our New Net Price Catalog for Blacksmiths, Wagonmakers, Horse-shoers, and Automobile Repairmen.

It contains thousands of articles you can use in your business and thousands you can sell to your trade on which you can make good money; 3,000 illustrations.

Tells how you can work up a profitable auto supply and repair business. Serves as a price guide on all supplies for blacksmith, carriage and wagonmaker, horseshoer, and auto repair man.

It is a book that will save you money on anything you need in your shop and make you money on the thousands of things you can sell to your trade.

Write for your copy today, sending business card, letterhead or some other evidence that you are in the trade.

**CRAY BROTHERS,**  
1113 W. 11th Street,

**CARRIAGE HARDWARE AND  
AUTO ACCESSORIES,**  
Cleveland, Ohio, U. S. A.



*Little Giant*

## Combination Screw Plates

*For General and Automobile Repairs*

Contains both U.S. and S.A.E. Std. Taps and Dies.

One set takes the place of two. This means a good saving to you.

You do not have to pay for duplicate Tap Wrenches and Stocks.

You have but *one* case which contains all the Taps and Dies the average shop needs.

A place for everything makes it easy to keep everything in its place.

Send for new catalog No. 37



**Greenfield Tap and Die Corporation**

**GREENFIELD, MASS.**

NEW YORK                      CHICAGO                      LONDON  
Canada Fractory, Wells Brothers Company of Canada, Ltd., Galt, Ont.



# Makes Money For You!!!

**M E C O**

BLACKSMITHS and repair men find M E C O Welding Apparatus increases their profits by enabling them to do better work—and all kinds of welding and cutting jobs. M E C O Torch works perfectly as either a cutter or welder. Designed for all classes of work. Different angle heads as supplied with M E C O are necessary for good welding. M E C O Torch can be shortened or lengthened. Ample capacity prevents burning of welds. M E C O meets all requirements.

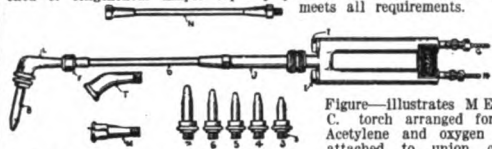

Figure—illustrates M E C O Type C torch arranged for welding. Acetylene and oxygen hoses are attached to union connections

H. & G. respectively. Different angle heads T. L. & M. are attached with union nut F. To make torch longer, attach extension N. between members O. & J. Write for information about M E C O Welding Apparatus and M E C O Carbon Remover. 900% profit in removing carbon from auto cylinders. MODERN ENGINEERING CO. 1403 St. Charles Street, St. Louis, Mo.

## OXY-Acetylene Welding Apparatus

### TURN THAT STREAM OF PROFITS INTO YOUR SHOP

Why longer let the good money in oxy-acetylene welding pass on to another shop? It is ready to stop at your door if you do the work. And all you need do to capture these good extra profits and make a welding reputation for your shop is to put in this

#### IDEAL WELDER

Then you are ready to tackle the largest or smallest welding jobs with complete success. And you do not have to make a large investment—the IDEAL outfit is low priced enough to pay for itself in an unusually short time.

You will be well repaid if you write immediately for complete information regarding the IDEAL outfit.

GENERAL WELDING CO.

394 14th Street, Hoboken, N. J.

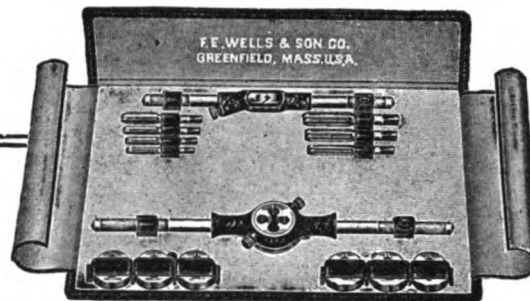
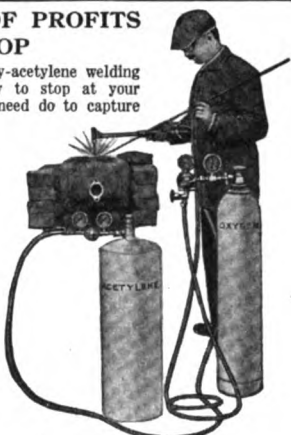

### No. 6471

This O. K. Screw Plate put up in a Leather Roll is just what you need for emergency work and will be found just as practical as Screw Plates in Wooden Boxes.

Your *emergency car* needs one to be complete.

## F. E. WELLS & SON COMPANY,

Greenfield,  
Mass., U. S. A.



You should have our  
7-A CATALOG on  
Thread Cutting Tools

# Only a Few Left---

There are still unsold a few of the books advertised last month. Those left go to first comers, so if you want to secure one or more valuable books at bargain prices, better act at once.

The Modern Gas Tractor, Its Construction, Operation, Application and Repair, by Victor W. Page, 1913 Edition. Regular Price, \$2.00; Sales Price, \$1.00.

The 20th Century Toolsmith and Steelworker, by H. Holford, 1907 Edition. Regular Price, \$1.50; Sales Price, \$1.00.

Brook's Automobile Hand Books. Regular Price, \$2.00; Sales Price, \$1.25.

Gas, Gasoline and Oil Engines, by Gardner D. Hiscox, 1906 Edition. Regular Price, \$2.50; Sales Price, \$1.50.

Dyke's Automobile & Gasoline Engine Encyclopedia, by A. L. Dyke, 1913 Edition. Regular Price, \$3.00; Sales Price, \$1.50.

Automobile Troubles and How to Remedy Them. Regular Price, \$1.00; Sales Price, \$.50.

Oxy-Acetylene Welding and Cutting. Regular Price, \$1.00; Sales Price, \$.75.

Prof. Rich's New Artistic Horseshoeing. Regular Price, \$2.00; Sales Price, \$1.25.

The Modern Gasoline Automobile, Its Construction, Operation, Maintenance and Repair, by Victor W. Page, 1913 Edition. Regular Price, \$2.50; Sales Price, \$1.50.

These books are slightly 'shelf-worn' but every book is complete and in good condition. These special prices include packing and postage and apply *only* to the few books now in stock. We cannot furnish copies of the above books after the present limited stock is sold. If you want one or more, send in your order and remittance NOW to insure getting the book you want. Address

### BOOK DEPARTMENT

## American Blacksmith Company, Box 974, Buffalo, N. Y.





90,000 Springs In Stock — For Every Car



Write FOR CATALOG and DISCOUNTS DISPLAY RACK FREE WITH ORDER FOR 12 ASSORTED

Jenkins Vulcan Spring Co.

Saint Louis, Mo. .... 1402 Chestnut St.  
Minneapolis, Minn. .... 1024 Hennepin Av.  
Reading, Pa. .... 538 Franklin St.  
Fort Worth, Tex. .... 708 Commerce St.  
Sumter, S. C. .... 29 Caldwell St.

STAR STEEL SHAPES



Quick Repairs for Rush Seasons. Standard shapes for plows, cultivators, listers, etc.

Soft Center Solid Cast Crucible  
STAR MANUFACTURING CO.  
CARPENTERSVILLE, ILL.

YOU CAN WELD STEEL AS EASILY AS IRON



Especially adapted for welding tires, axles, springs and all lap welding.

Either of these compounds will weld steel at the lowest possible heat that steel can be welded. Also protects steel at high heat.

Owing to our improved process of manufacturing, these compounds do not boil off and waste in the fire, but adhere to the metal when applied.

FOR SALE BY ALL LEADING DEALERS IN BLACKSMITH SUPPLIES IN UNITED STATES AND CANADA

Large Free Sample Sent on Request

CORTLAND WELDING COMPOUND CO., Cortland, N. Y.



PREPARED ESPECIALLY FOR WELDING FAR SUPERIOR TO COMMON BORAX

A flux which causes the steel to weld like iron. Not necessary to apply between the lap, but may be applied to the outer surface of the work, the same as borax. Has no equal for plow work. Just the thing for welding too-calks so they can't knock off.

Norton Wheels in the Blacksmith Shop

The wheel for the blacksmith shop must be adapted to a great variety of work in order to be economical.

The wheels usually recommended for general use in blacksmith shops are 24 P and 24 Q ALUNDUM, sometimes, however, a 30 P or Q is used to better advantage.

If a fair finish is desired, good results may be obtained with a 36 O ALUNDUM, but if the finish is to be fine, wheels 46 N or O are commonly used.

Wherever the speeds are low, a harder wheel will be found more satisfactory, but if possible, the wheels should be operated at 5000 to 6000 surface feet per minute.

Norton Company Worcester, Mass.

NEW YORK STORE 151 CHAMBERS STREET

CHICAGO STORE 11 N. JEFFERSON STREET

ELECTRIC FURNACE PLANTS NIAGARA FALLS, N. Y. CHIPPEWA, ONT., CANADA





# Make \$80 for Five Hours' Work!

Two enterprising young mechanics of Augusta, Kansas, recently repaired the head of the large pump, here illustrated. They used an IMPERIAL Torch, and for making the weld received \$80. The job was finished within five hours!

Every blacksmith has the same opportunity to make big profits. By the use of

## IMPERIAL WELDING EQUIPMENT CUTTING OXY-ACETYLENE PROCESS

your field of usefulness will be tremendously enlarged. With an IMPERIAL Outfit you can **weld anything in metal** and you will be enabled to repair broken machinery of all kinds in a few minutes or a few hours. Also you can get your share of the profits from automobile repairing in your community.

The first cost of an IMPERIAL Outfit is often not more than earned by a single operation.

**Get the facts.** Learn how easy IMPERIAL Equipment is to handle—

it's low operating cost—the wonderful money-earning possibilities with one. Write for the new Catalog, giving complete information, and prices. **Write Today.**

*No. 1  
Welding  
Outfit*

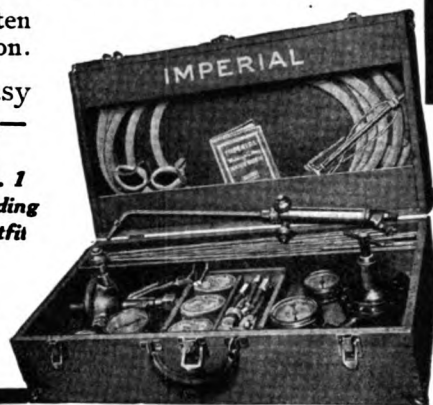

**The Imperial Brass Mfg. Co.,**  
1220 W. Harrison Street, Chicago, Ill.

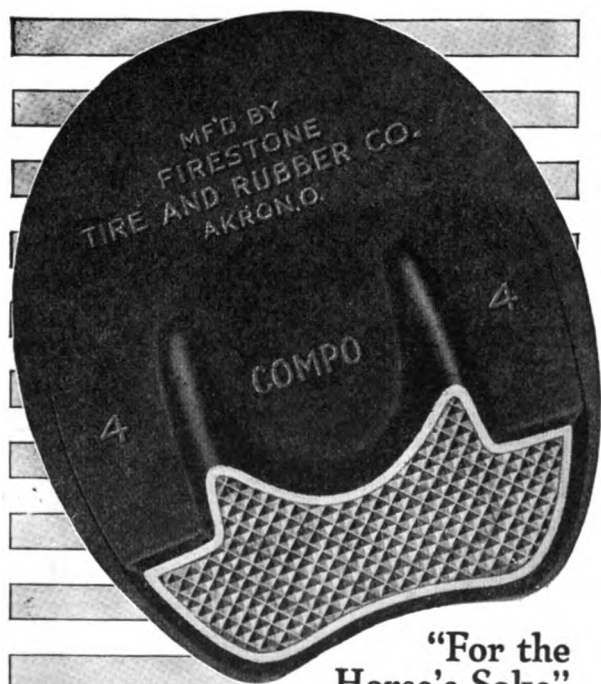

"For the Horse's Sake"

# Firestone

## COMPO HOOF PADS

The new Firestone Compo gives long, durable service. It's the last word in hoof pad quality and economy. Other styles and shapes for every service and fitting.

Investigate this quality line today.

FIRESTONE TIRE & RUBBER COMPANY  
AKRON, OHIO





**YOU CAN'T CUT OUT A  
Bog Spavin or Thoroughpin**  
but you can clean them off promptly with



**ABSORBINE**  
TRADE MARK REG. U.S. PAT. OFF.

and you work the horse same time. Does not blister or remove the hair. \$2.00 per bottle, delivered. Will tell you more if you write. Book 4 M free. ABSORBINE, JR., the antiseptic liniment for mankind, reduces Varicose Veins, Ruptured Muscles or Ligaments, Enlarged Glands, Wens, Cysts. Allays pain quickly. Price \$1 and \$2 a bottle at druggists or delivered. Made in the U. S. A. by W. F. YOUNG, P.D.F., 230 Temple St., Springfield, Mass.



**SEBASTIAN**  
13-14 and 15 inch Swing.  
The Sebastian Lathe Co. 124 Culvert Street, Cincinnati, O., U.S.A.

**EMPIRE STEEL WHEELS**  
Plain or Grooved Tire  
To Fit Any Wagon  
**Farm Trucks**  
All Standard Types  
Write today for Proposition to Blacksmiths.  
Empire Mfg. Co.  
P. O. Box 307  
QUINCY, ILLINOIS



**The Perfect Power Hammer**  
The Simplest in Construction  
The Most Effective in Operation  
The Most Durable and  
**THE BEST**  
MADE IN TWO SIZES:  
3 inch square, 40 lb. ram — shipping weight, 1,100 lbs.  
4 inch square, 80 lb. ram — shipping weight, 1,800 lbs.  
Write any jobber for Prices, or  
**MACGOWAN & FINIGAN  
FOUNDRY & MACHINE CO.**  
204 North Third Street  
ST LOUIS, MO.



## CLASSIFIED BUYERS GUIDE

For Alphabetical Index to Advertisers See Page 13

	Page		Page
<b>Anvils</b>		<b>Drilling Mach., Hand &amp; Power</b>	
Columbus Anvil & Forging Co. 48		Buffalo Forge Company... 4	
Columbus Forge & Iron Co. 7		Canedy-Otto Mfg. Co. .... 8	
Hay-Budden Mfg. Co. .... 52		Champion Blower & Forge Company ..... 11	
<b>Automobiles</b>		<b>Drilling Machines, Electric</b>	
Bush Motor Co. .... 13		Buffalo Forge Company... 4	
<b>Automobile Parts</b>		Champion Blower & Forge Company ..... 11	
Harvey Spring & Forging Co. 48		<b>Emery Stands</b>	
Mowers Mfg. Co. .... 52		Crescent Machine Company. 37	
A. Wheel, Top & Hdwe. Mfg. Co. .... 6		<b>Engines, Gas and Gasoline</b>	
<b>Axle Gauges</b>		Foos Gas Engine Company. 52	
Cray Brothers ..... 38		Galloway Co., William.... 46	
<b>Ball &amp; Roller Bearings</b>		Modern Engineering Co. ... 39	
Gwilliam Co. .... 46		Witte Engine Works..... 46	
<b>Blowers, Hand</b>		<b>Files and Rasps</b>	
Buffalo Forge Company... 4		Heller Brothers Company.. 42	
Canedy-Otto Mfg. Co. .... 8		Nicholson File Company... 14	
Champion Blower & Forge Company ..... 11		<b>Forges</b>	
<b>Blowers, Electric</b>		Buffalo Forge Company... 4	
Buffalo Forge Company ... 4		Canedy-Otto Mfg. Co. .... 8	
Canedy-Otto Mfg. Co. .... 8		Champion Blower & Forge Company ..... 11	
Champion Blower & Forge Company ..... 11		<b>Gears</b>	
Electric Blower Company.. 13		Akron-Selle Company .... 47	
<b>Bolt Clippers</b>		<b>Grinding Wheels</b>	
H. K. Porter..... 44		Norton Company ..... 40	
<b>Brasing Forges</b>		<b>Grain for Polishing</b>	
National Rubber & Spec. Co. 47		Norton Company ..... 40	
<b>Calks</b>		<b>Grinding Machinery</b>	
Diamond Calk Horse Shoe Co. 51		Norton Company ..... 40	
Franklin Steel Works.... 49		<b>Hammers, Power</b>	
Phoenix Horseshoe Co. .... 5		Macgowan & Finigan .... 42	
The Rowe Calk Co. .... 1		Mayer Bros. Co. .... 49	
<b>Calking Machines</b>		West Tire Setter Company. 50	
L. S. P. Calking Mach. Co. 44		<b>Hoof Nippers</b>	
<b>Carriage Parts</b>		Lowe Mfg. Company ..... 43	
A. Wheel, Top & Hdwe. Co. 6		Muncie Wheel Company... 18	
C. C. Bradley & Son ..... 12		<b>Horseshoes</b>	
Cray Brothers ..... 38		Bryden Horseshoe Company 9	
<b>Carriage Tires</b>		Diamond Calk Horse Shoe Company ..... 51	
Firestone Tire & Rubber Co. 41		Giant Grip Horse Shoe Co. 45	
<b>Chucks</b>		Phoenix Horseshoe Co. .... 5	
Buffalo Forge Company... 4		United States Horseshoe Co. 9	
Canedy-Otto Mfg. Co. .... 8		<b>Horseshoe Nails</b>	
Champion Blower & Forge Company ..... 11		Capewell Horse Nail Co. ... 52	
<b>Coal and Coke</b>		Union Horse Nail Company 50	
Pennsylvania Coal & Coke Corp. .... 3		<b>Horseshoe Pads</b>	
<b>Decarbonizing Outfits</b>		Beals, McCarthy & Rogers.. 44	
General Welding Company. 39		Firestone Tire & Rubber Co. 41	
<b>Horse Stocks</b>		<b>Horse Stocks</b>	
Barcus Mfg. Company .... 50		Beals, McCarthy & Rogers.. 44	
<b>Iron</b>		Campbell Iron Co. .... 44	
Beals, McCarthy & Rogers.. 44		<b>Jobbers</b>	
Campbell Iron Co. .... 44		Campbell Iron Company... 44	
<b>Machines, Threading</b>		Cray Brothers ..... 38	
Greenfield Tap & Die Corp. 38		Cummings & Emerson .... 44	
<b>Oxy-Acetylene Welding Outfits</b>		Milton Mfg. Company..... 47	
American Welding Co. .... 48		<b>Machines, Threading</b>	
Berno Supply Co. .... 46		Greenfield Tap & Die Corp. 38	
Economy Welding Mach. Co. .... 44		<b>Oxy-Acetylene Welding Outfits</b>	
Henderson-Willis Welding & Cutting Co. .... 52		American Welding Co. .... 48	
Imperial Brass Mfg. Co. ... 41		Berno Supply Co. .... 46	
The Linde Air Products Co. 37		Economy Welding Mach. Co. .... 44	
<b>Oxygen</b>		Henderson-Willis Welding & Cutting Co. .... 52	
The Linde Air Products Co. 37		Imperial Brass Mfg. Co. ... 41	
<b>Paints</b>		The Linde Air Products Co. 37	
Felton, Sibley & Co., Inc... 14		<b>Patent Attorneys</b>	
<b>Patent Attorneys</b>		Chandlee & Chandlee .... 44	
Chandlee & Chandlee .... 44		Watson E. Coleman ..... 44	
Watson E. Coleman ..... 44		Evans & Company, Victor J. .... 44	
Evans & Company, Victor J. .... 44		Herbert Jenner ..... 44	
Herbert Jenner ..... 44		C. L. Parker ..... 44	
C. L. Parker ..... 44		Randolph & Company .... 44	
Randolph & Company .... 44		<b>Poles &amp; Shafts</b>	
<b>Poles &amp; Shafts</b>		A. Wheel, Top & Hdwe. Co. 6	
A. Wheel, Top & Hdwe. Co. 6		Crandal, Stone & Company. 52	
Crandal, Stone & Company. 52		<b>Punches</b>	
<b>Punches</b>		Buffalo Forge Company... 4	
Buffalo Forge Company... 4		Little Giant Punch & Shear Company ..... 48	
Little Giant Punch & Shear Company ..... 48		Plymouth Foundry & Mach. Company ..... 43	
Plymouth Foundry & Mach. Company ..... 43		<b>Rasps (See Files)</b>	
<b>Rasps (See Files)</b>		<b>Beamers</b>	
<b>Beamers</b>		Greenfield Tap & Die Corp. 38	
Greenfield Tap & Die Corp. 38		<b>Rubber Tires</b>	
<b>Rubber Tires</b>		Firestone Tire & Rub. Co. ... 41	
Firestone Tire & Rub. Co. ... 41		<b>Saws, Band</b>	
<b>Saws, Band</b>		Crescent Machine Company 37	
Crescent Machine Company 37			

**TOOLS** for shop, factory, garage and home, many high class tools attractively priced in our "Odds and Ends" pamphlet—which is mailed free on request by  
107 Fulton Street  
**MONTGOMERY & CO., Inc., NEW YORK CITY**

**THE HORSE RASP OF QUALITY**



Ask your dealer for the IMPROVED HELLER RASP with keen cutting hard teeth. Made in all patterns and cuts, "Slim," "Light," "Slim Light," and "Fine Cut." Insist on getting the size, kind and cut best suited for your work. It will pay you to give them a trial. New catalogue mailed free on application.  
ESTABLISHED IN 1834  
**HELLER BROTHERS COMPANY** NEWARK, N. J.



CLASSIFIED BUYERS GUIDE (Continued)

<b>Schools</b>	Page	<b>Stocks and Dies</b>	Page	<b>Vises</b>	Page
Greer College of Motoring.	88	Butterfield & Company....	48	Columbian Hardware ....	37
Nebraska Auto School ....	48	Canedy-Otto Mfg. Co. ....	8	Columbus Forge & Iron Co. 7	
<b>Screw Plates</b>		Champion Blower & Forge		Prentiss Vise Company....	44
Butterfield & Company....	48	Company .....	11	<b>Vulcanizers</b>	
Greenfield Tap & Die Corp.	38	Greenfield Tap & Die Corp.	38	Charles E. Miller .....	43
Hart Mfg. Company .....	47	Hart Mfg. Company .....	47	<b>Welding Compound</b>	
F. E. Wells & Son Company	39	F. E. Wells & Son Company	39	Anti-Borax Compound Co..	50
<b>Shaft Couplings</b>		<b>Tire Heaters</b>		Cortland Welding Compound	40
C. O. Bradley & Son.....	12	West Tire Setter Company.	50	<b>Welding Outfits</b>	
<b>Shaft Ends</b>		<b>Tire Setters</b>		American Welding Co. ....	48
Crandal, Stone & Co.....	52	Brooks Machine Company..	44	General Welding Company	39
<b>Shears</b>		Buffalo Forge Company ...	4	Imperial Brass Mfg. Co... 41	
Buffalo Forge Company... 4		Canedy-Otto Mfg. Co. ....	8	Vulcan Process Company..	38
C. D. Edwards..... 18		Champion Blower & Forge		<b>Wheels, Wood</b>	
Little Giant Punch & Shear		Company .....	11	A. Wheel, Top & Hdwe. Co. 6	
Company .....	48	<b>Tongs</b>		Cray Brothers .....	38
Plymouth Foundry & Mach.		Champion Tool Company..	12	<b>Wheels, Metal</b>	
Company .....	48	<b>Tops and Trimmings</b>		Electric Wheel Company... 18	
Simonsen Iron Works.....	47	A. Wheel, Top & Hdwe. Co. 6		Empire Mfg. Company.... 42	
<b>Springs</b>		<b>Tuyere Irons</b>		Havana Metal Wheel Co.. 44	
Harvey Spring & Forging		Buffalo Forge Company ... 4		<b>Wood Working Machinery</b>	
Company .....	43	Champion Blower & Forge		Buffalo Forge Company... 4	
Higgins Spring & Axle Co. 2		Company .....	11	Crescent Machine Company 37	
Indianapolis Bolster Spring		<b>Varnishes</b>		Parks Ball Bearing Mach-	
Company .....	9	Felton-Sibley & Company.. 14		ine Company .....	49
Jenkins Vulcan Spring Co. 40		<b>Vehicle Parts</b>		Sidney Tool Co. ....	49
Raymond Mfg. Co. ....	49	Cray Brothers .....	38	Whisler Mfg. Co. ....	46
Tuthill Spring Co. ....	10	<b>Veterinary Remedies</b>		<b>Wrenches</b>	
<b>Steel</b>		G. E. Conkey .....	18	George A. Cutter .....	48
Beals, McCarthy & Rogers. 44		Newton Remedy Company.. 18		Cray Brothers .....	38
<b>Steel Shapes</b>		W. F. Young .....	42		
Star Manufacturing Co.... 40					

**VULCANIZERS**

Free Instructions and Book with each outfit at Factory or by Mail.

**COMPLETE LINE**

Tire Vulcanizers, Wrapping Machines and Many Useful Devices for Tire Shops and Factories.

64-PAGE CATALOG ON REQUEST

1894 Established 22 Years 1916

CHAS. E. MILLER  
Anderson Rubber Works  
Factory and Office  
Anderson, Ind., U. S. A.



**Increase Your Shop Profits**

Don't turn down profitable auto repair jobs because you are afraid to tackle them.

Learn auto repairing from practical instructors.

Your increased profits will pay for the course many times over.

**THE NEBRASKA AUTOMOBILE SCHOOL**

offers a simple, easy-to-learn course which will give you a thorough, practical knowledge of automobile repairing in the space of only a few weeks.

Write for catalog and letters from our graduates.

**Nebraska Automobile School,**  
2026 Farnam Street,  
OMAHA,  
Nebraska.



**Quick Auto Spring Repairs** HERE is something that you need every day. Bundles of semi-finished spring repair plates. A large assortment to choose from. A main leaf with eye turned at one end, with each bundle.

Send for free copy of the Harvey Auto Spring Catalog. This book completely describes the Harvey repair plates, gives specifications and prices. Besides it gives complete specifications of over 600 different auto springs to fit nearly every known car. Over 15,000 Harvey "Boltless" Auto Springs in stock constantly to give you service.

**HARVEY SPRING & FORGING CO., RACINE, WIS.**



**Every Blacksmith and Repair Shop**

should save time, money and hard work by having a

**PLYMOUTH PUNCH AND SHEAR**

The only machine that will punch seven different size holes without removing the punches from the machine. Automatic sliding punch rack, no wrench required. Don't accept any other just as good.

Ask your supply house for circular and price or write to the

**PLYMOUTH FOUNDRY & MACHINE CO.**  
PLYMOUTH, WIS.

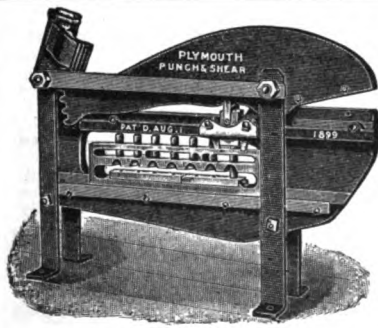

**Widest Opening**

**The Wagner & Lowe Hoof Nippers** are drop-forged from the best tool steel, hand tempered and hand finished throughout.

Horseshoers who have used them use no others.

For sale by all leading Jobbers

**Longest Leverage**

**The Lowe Manufacturing Co., Enderlin, N. Dak.**

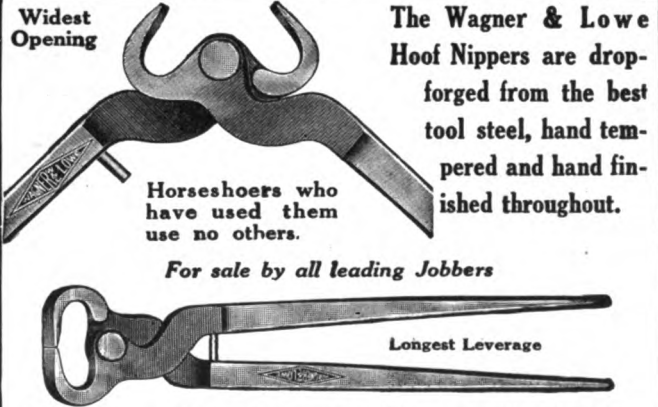



**CUMMINGS & EMERSON**  
**BLACKSMITH SUPPLIES**  
 Send for net price plow goods catalogue.  
**PEORIA, ILLINOIS**

## WANTED—AN IDEA

Who can think of some simple thing to patent! Protect your ideas, they may bring you wealth. Write for "Needed Inventions," "Patent Buyers," "Millions in Patents," "Patents for Sale," "How to Get Your Patent and Your Money," and other books. RANDOLPH & CO., Patent Attorneys, Dept. 796 Washington, D.C.

**PATENTS HERBERT JENNER,**  
 Patent Attorney and Mechanical Expert, 694 F St., Washington, D. C. Established 1883. I make a free examination and report if a patent can be had and exactly what it will cost. Send for circulars.

## PATENTS

**G. L. PARKER**  
 Ex-Member Examining Corps, U. S. Patent Office  
 Attorney-at-Law and Solicitor of Patents  
 American and foreign Patents secured. Trade marks registered. Searches made to determine patentability, validity and infringement. Patent Suits conducted. Pamphlet of instructions sent upon request.  
 McGill Building WASHINGTON, D. C.

**PATENTS** Write for How to Obtain a Patent. List of Patent Buyers and Inventions Wanted. \$1,000,000 in prizes offered for inventions. Send sketch for free opinion as to patentability. Our four books sent free.  
**VICTOR J. EVANS, 685 Ninth, Washington, D.C.**

**Inventions Wanted!**  
 Manufacturers constantly writing us for patents. List of inventions actually requested and book "How to Obtain a Patent" sent free. Send rough sketch for free report regarding patentability. Special assistance given our clients in selling patents. Write for details of interest to every inventor.  
**Chandlee & Chandlee, Patent Attorneys**  
 Est. 21 Years 910 F St., Washington, D. C.

**PATENTS That Protect and Pay**  
 Send Sketch or Model for Search.  
**BOOKS and ADVICE FREE**  
**Watson E. Coleman, Patent Lawyer, Washington, D.C.**

## HAVANA STEEL WHEELS



For your Farm Wagon, so as to make it a Low-Down, instead of having to do your work over the sides of a high wheeled wagon. No dry, loose wheels. More and easier work done.  
 Send postal for free catalog of Steel Wheels and Farm Trucks.  
**HAVANA METAL WHEEL CO.,**  
 Box 85 Havana, Ill.

**The Campbell Iron Company**  
 Distributors of Oxy-Acetylene Welding Equipment and general Blacksmith Shop Supplies.  
 Catalog sent on request.  
**821 CASS AVE. • ST. LOUIS, MO.**

**Beals, McCarthy & Rogers**  
 Formerly Beals & Company  
**Blacksmiths and Wagonmakers Supplies :: Iron Steel Hardware**  
**Buffalo, N. Y.** Largest stock in New York State

## WANTED AND FOR SALE

Want and For Sale advertisements, situations and help wanted, twenty-five cents a line. Send cash with order. No charge less than fifty cents. The small cost of these advertisements prevents our investigating and guaranteeing them. WE WILL NOT knowingly accept any but reliable ones.

**WANTED—Men with Patentable Ideas, write RANDOLPH & CO., Patent Solicitors, Dept. 289 Washington, D. C.**

**WANTED—To hear from owner of good Blacksmith Shop for sale. State cash price, description.**  
**D. F. BUSH, Minneapolis, Minn.**

**MAKE MONEY vulcanizing tires while business is good. Add a thousand dollars to your income. Our book, just out \$1.00, tells you how to do the work.**  
**VANDERPOOL CO., Springfield, Ohio.**

**FOR SALE—Blacksmith shop, tools and stock; doing good business; only shop in town. Address Box 2 or call and see me.**  
**J. A. McDONALD, Radersburg, Mont.**

**FOR SALE—New machines, immediate delivery: 5-inch Bench Jointer, \$20.00; 9-inch Complete Jointer, \$35.00; 13-inch Complete Jointer, \$55.00. Circular and square style cutter heads from 5-in. up to 17-in. long. Also combination outfits, saw arbor and cutter heads. Send for catalogue and prices.**  
**W. L. SHERWOOD, Kirksville, Mo.**

**FOR SALE—One of the best Blacksmith shops in Central Ohio. Ask for price, description and reason for selling.**  
**B. B. SLACK, Lewis Center, Ohio.**

**WANTED—Blacksmith. German. \$3,000. Address A. B., Care American Blacksmith.**

**RARE OPPORTUNITY—A blacksmith shop in Utah city, central of about 5,000 population, shop, tools, material and power tools, will sell or trade, plenty of work, full size lot, 4-room house with modern improvements. Investigate at once. BOX No. 0276, Richfield, Utah.**

**FOR SALE—Best location in Southwest Texas for a general Blacksmith and Auto repairing business. Windmills, pipe and pipe fittings; small stock of implements and shelf hardware. Plenty of work the year round for 2 men. Price, \$6,500.00. Reason for selling, have other business to attend to. For further particulars, address P. O. BOX 16, Fannin, Tex.**

**FOR SALE—Three new No. 1 Stoddard Tire upsetters at \$5.75 each. One No. 2 at \$12.00. One Schaw Cold Set Tire Upsetter, second hand, but in good condition, at \$15.50.**  
**CRANE & BISSELL, Norwich, N. Y.**

**WANTED—An eastern technical and trade school has an opening for a young man with good shop training as assistant instructor of forging, hardening and tempering. Address: W. I., Care The American Blacksmith Co.**

**WANTED—Salesmen calling on Blacksmiths to carry a side line. A liberal commission given. Address: B. GARDNER ELECTRIC & MFG. WORKS, 1712 Columbus Road, Cleveland, Ohio.**



**Prentiss Patent Vises**  
**BEST MADE**  
 Large Illustrated Catalog Free  
**Prentiss Vise Co., Hardware Bld., New York**

**"NEW EASY" 4 Sizes BOLT CLIPPERS "EASY" 2 Sizes**  
**THE GENUINE TOOL**  
**H. K. PORTER EVERETT, MASS. U. S. A.**  
**KNOWN AND PREFERRED EVERYWHERE**



## 1918 Model The L. S. P. Calking Machine

The Greatest Time and Labor Saving Machine on Earth

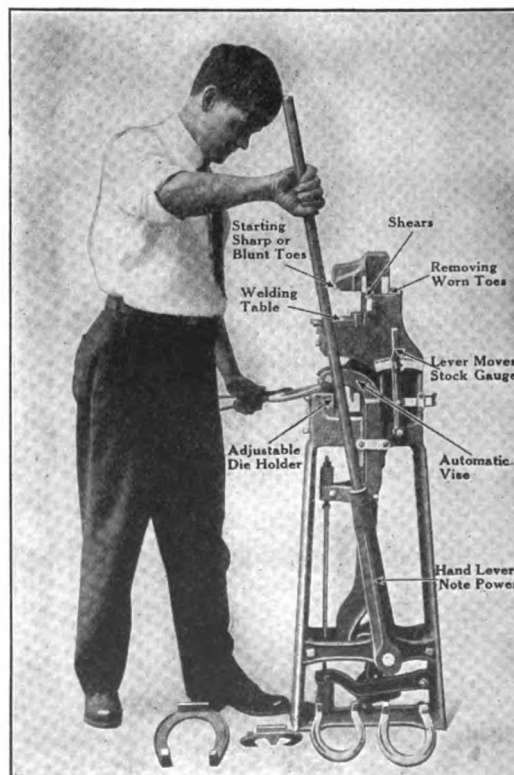

OUR 1918 Model is the same as our 1917 Model with the exception that we have eliminated the steel pluggers attachment and strengthened some of the parts.

Do not mistake this for a machine which makes toe calks or a foot vice. This machine is for turning heel calks, both Blunt and Sharp, sticking and welding toe calks, clipping and trimming ends of shoes. IT CALKS SHOES, doing the work just the same as you do by hand with the hammer, only it is done much better and easier, and in a fraction of the time.

In turning heels, you can turn up just as much stock as you wish, upset or stove up to make as heavy as you like and square up the calks without use of hammer. There is no losing of toes when you weld on the L. S. P.

It is a strong, handsome, well-made machine, and will last, as you might say, a life time, fully warranted for one year. It is in use in the best shops in the United States, users claiming more for it than we do. Write at once for full information and prices.

**L. S. P. CALKING MACHINE COMPANY**  
 Peoples' State Bank Building  
 Wyalusing, Pa., U. S. A.  
 National Machine Co.,  
 Brighton, Ont., Canada

1918 MODEL Fully covered with Patents



## Your Customers

will always come back  
if you use only

*Genuine  
Giant Grip  
Calks*

Perfect fitting shanks.

Properly tempered.

Strongest where strength  
counts.

Sixteen years of successful  
manufacturing experience  
behind every *Giant Grip*  
Calk and Shoe.

**Order Now — Be Prepared**

*All Leading Jobbers Can Supply You.*

**Giant Grip Horse Shoe Company**  
**Oshkosh, Wisconsin**

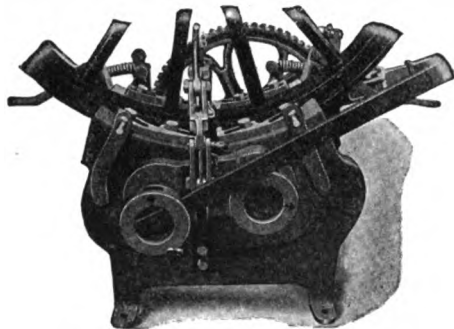

### The Brooks Cold Tire Setter

Sets tires cold on the wheel and is the pioneer edge-grip hand-power cold tire setter. Used and officially endorsed by the United States Government in the Department of War and Interior. Thousands of blacksmiths in the U. S. consider it the most profitable machine in their shop. We build both hydraulic and lever cold tire setters. The Brooks does the work quicker and better than any other cold tire setter on the market and should be in every blacksmith and carriage repairer's shop. Write for catalog and prices.

We are also manufacturers of the latest improved Oxy-Acetylene Welding machines and generators, equipped with our famous Safety Flash Back Valve. It prevents explosions.

We also build Welding Outfits to be used with cylinder gases.

Our catalog will interest you and is free for the asking.

The Brooks Machine Company, Wichita, Kansas

### FODEN'S MECHANICAL TABLES

SAVE ALL FIGURING!

Tell at a glance how much stock to use for oval or elliptical hoops of any size, the circumferences of circles, weight of flat, square and round stock, and the weight and strength of ropes and chains

Should be in every progressive Smith's hands Bound very neatly in green cloth. Price, 50c. AMERICAN BLACKSMITH COMPANY, Buffalo, N.Y.

# POWER!



### for Your Shop

Blacksmiths and Wheelwrights: Investigate at once the wonderful Galloway Gas Engines for reliable shop power. They are built to do all kinds of hard work and deliver economical, reliable service every day. They are simple and easy to operate—give steady power on any kind of job—long stroke, large bore, heavy weight. Develops way above rated horsepower. Uses any fuel. Fool proof and frost proof. Every part standardized and interchangeable. Guaranteed in every way. Engines shipped on short notice. Over 100,000 Galloway Engines in use.

Buy Direct—Save 25% to 40%

I cut out all agents and dealers. I sell you the famous Galloway Engine (any size up to 16 H. P.) direct from my great engine factories, saving you 25% to 40% on the best engine built.

Write Before you decide on any kind of power write for my big En-

gine Book and learn the details of my Engine offer. You'll save money if you do. Write today. Wm. Galloway, Pres. WM. GALLOWAY CO. Box 925 Waterloo, Iowa

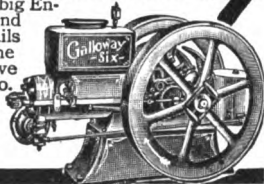

### BALL AND ROLLER BEARINGS ALL TYPES

Sole Agents for the U. S. of The Bowden Patent Wire Mechanism for the Transmission of Reciprocating Motion through a Flexible and Tortuous Route. THE GWILLIAM COMPANY Engineers

253 W. 58th St. (at Broadway), NEW YORK

### The Wood Worker's Friend



Get directions for building table and operating our Jointer's. This information is valuable to wood workers. We manufacture 20 styles and sizes. Try a Jointer Head 30 Days, if you are not pleased, return at our expense. Get prices. Mfg. by WHISLER MFG. CO., Gibson, Iowa



ED. H. WITTE

# I Can Make You The Best PRICE

## On a Kerosene Engine

Sell You a Better Engine—Save You \$25 to \$100

Not an experiment! Hundreds in Use! Better and more powerful than ever! Starts as easily as a gasoline engine! Will use any fuel that can be used in a Kerosene engine! You get three times as much power for the money at present fuel prices! Your own terms! Cash, Deposit, Payments, or No Money Down! If you are in the market, write me today! I CAN MAKE YOU THE BEST PRICE—Sell You a BETTER Engine—Ship At Once! Any Style—Stationary or Portable.

# WITTE ENGINES

Kerosene and Gasoline—2 to 22 H-P.

are made in the largest exclusive direct selling engine factory in the world. I make nothing but engines. Over 30 years success proves quality—immediate shipment proves superior factory equipment and business methods—just as my engines are superior. You can see the high quality in every line and curve. Look at the long solid base affording absolutely solid footing. See how cleanly-built—no cumbersome overweight of metal—no cylinder hanging out behind—no interior packing—vertical valves and many other special features that make WITTE Engines high-grade, better, and more desirable. 90-Day Trial will fully convince you of superior quality. Write for latest price and free book, or come to factory and see them—You are welcome. Ed. H. Witte,

FREE



### WITTE ENGINE WORKS

1769 Oakland Ave., Kansas City, Mo. 1769 Empire Bldg., Pittsburgh, Pa.

Write for this Beautiful 4 Color Illustrated FREE BOOK Today! Yours for a Post Card—by Return Mail.

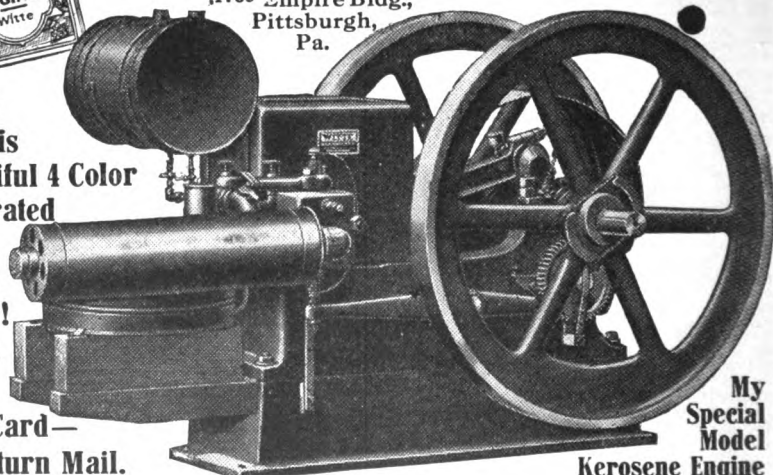

My Special Model Kerosene Engine

# Zeke Kennedy

hangs out near the  
C. M. & St. P.  
where it runs through his  
town.

An' he's been a-gettin' a  
lot of repairin' lately for  
the railroad—since he  
put a **LITTLE GIANT  
POWER HAMMER** in  
his shop.

Zeke says he's the only one  
in his town as can handle their  
jobs—an' there ain't another  
customer that pays so well nor  
sure.

Why don't you—Mr. Blacksmith,  
find out what a Little Giant can do  
for YOUR shop?

You'll be put wise by dropping a line  
to your jobbers or to us—TODAY.

**Mayer Brothers Company,**

101 Rock St.,

Mankato, Minnesota,

U. S. A.



Extract from page 324 of the June, 1917,  
issue of *The Horseshoers' Journal*

Horseshoeing business in Albany opened very quietly  
this spring. In fact, we still feel the harmful effect that  
the drive calks has done the business, but strikes in the  
building line has also effected trade, a large number of  
horses owned by contractors are remaining unshod, and are  
still carrying (to May 10th) their winter shoes of drive  
calk variety. **CHARLES W. KIRK.**

## ARE YOU IN THIS BOAT?

John Wiseman says to Bill  
from Missouri:



"It's time for a lot of you fellows to  
wake up. Ram your hand down into  
your pocket and see if the cash jingles  
with the merry sound as of yore."

"If not, why not?"

"There's a Reason, of course. And that  
reason is that you've been using calks that  
the owner can replace himself. Natural-  
ly his horses come less frequently to your  
shop. You have less business—less cash  
to jingle in your jeans."

"Do you get the idea?"

Every set of *welded calks* you put on helps to keep your  
shop full because the horses must be brought to you to have  
the worn calks replaced. And the users are satisfied users  
too.



Use **SWEET'S TOE  
CALKS**—"The  
Cold Cut  
Dreadnaught"  
(No. 2)

**FRANKLIN STEEL WORKS**

Joliet, Ill. Cambridge, Mass. Hamilton, Ontario

## WHY TRY TO GET ALONG WITHOUT THE FAMOUS?

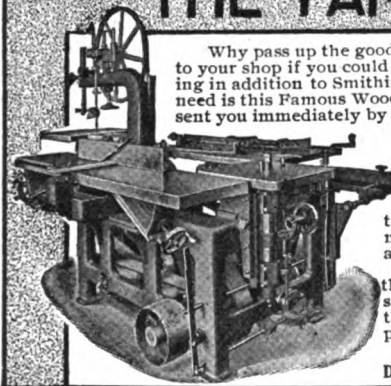

Why pass up the good extra dollars that would come  
to your shop if you could handle all kinds of woodwork-  
ing in addition to Smithing and Horseshoeing? All you  
need is this Famous Woodworker and you can have one  
sent you immediately by accepting our

### Special Easy Payment Plan

While it is earning its low  
purchase price—you can get a  
Famous for only \$125—it will  
be developing a nice extra  
trade for you that will put a good  
many extra profit dollars to your  
account each week.

Write for circular describing  
the Famous models and the  
special attachments which make  
them doubly useful and doubly  
profitable. Do it NOW.

**SIDNEY TOOL COMPANY**  
Dept. 14, Sidney, Ohio, U. S. A.

## Parks' Single and Combination Wood Working Outfits

We were the originators of the Circular Saw,  
Band Saw, Jointer Combination; our latest improve-  
ment is the 6 in. Jointer with undercut attachment  
for sizing material—joints by passing material  
over cutter head  
and sizes it by  
passing it back  
under the cutter  
head. All ma-  
chines ready for  
instant use.

Machines are  
made in large  
quantities which  
enable us to sell  
at lowest prices  
and make im-  
mediate ship-  
ment.

Write for Catalog

**Parks Ball Bearing Machine Co.**  
4100 Fergus St., Cincinnati, Ohio

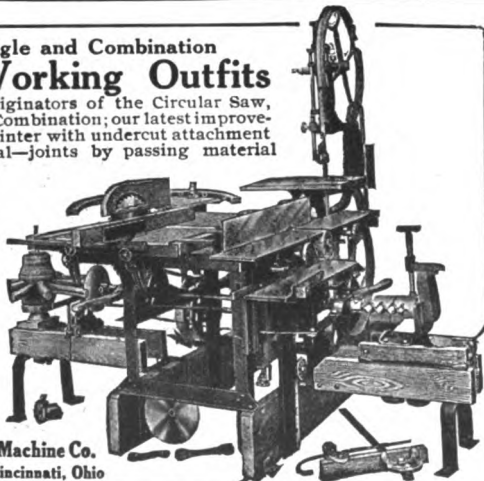

## RAYMOND POLE SPRINGS

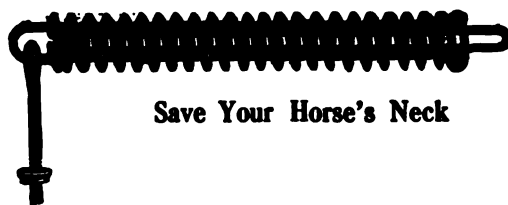

Save Your Horse's Neck

### Keystone Trace Spring

Why not befriend your horse  
and prolong his life by using this  
Trace Spring.

### Keystone Brake Springs



Write your Jobber for Circular and Prices

**RAYMOND MANUFACTURING CO.**

**CORRY - LIMITED - PA.**





### ONE KICK MIGHT COST

a hundred dollar doctor bill and keep you out of the shop for months—in fact nearly ruin your business. Why take the chance? Make sure such a disaster can't happen to you by simply using

#### Barcus Safety Horse Stocks

Entirely different from the old style horse stocks with their bothersome ropes, straps and buckles. All chances for injury are removed by the Safety Foot Clamp—a fortunately discovered automatic device that holds the foot like a vise. Its action is positive, quick and safe—you do not even have to touch the foot or limb of the horse.

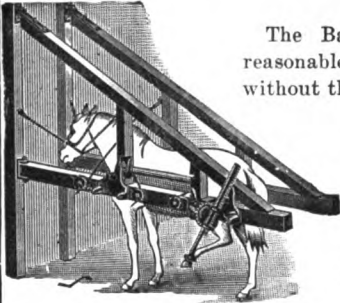

The Barcus sells at a price so reasonable no smith can afford to be without the protection of these stocks. As you value your life and health, as you seek to protect and support your family, do them and yourself the justice of writing for complete information without delay.

The Barcus Mfg. Co.,

Wabash,

Indiana.



### Northwestern Horse Nails ARE THE BEST ALL AROUND

#### For Strength, Safety And Quality Of Material

The most perfect in form and finish. Made of the Highest Grade Material to our own analysis. Will hold a shoe longer than any other nail made. Has a re-enforced point—making it easiest to drive and the safest to use.

Union Horse Nail Co.

Chicago, Ill.



TWO BIG HELPS IN WELDING

DON'T BE WITHOUT THEM



### "E-Z" Welding Compound

is the best BECAUSE it works equally good on all kinds of steel. It welds at lower heat than any other. It sticks to metal at a very low heat. It leaves no scale. Use it once and you will always want it.

### Crescent Welding Compound

makes smoother welds than any other. It is fine for plow work or where parts are fastened together before welding, or for making split welds, finishing heats, or for welding under dies, etc., etc. It insures smooth finish and perfect welds on Toe Calks.

"Money back" from any jobber if "E-Z" or Crescent does not give perfect results.

We Will Send Samples Free.

Made only by

Anti-Borax Compound Co.

FORT WAYNE, IND.

### THE ROCHESTER

#### HARD HITTING HELVE HAMMER

Made in many sizes to fit the exact requirements of your work. Write for illustrated booklet.

Here's a hammer that will make money for you, Mr. Smith, day in and day out. It will do the work of any other hammer, and then some. Made in six sizes—one of them is the hammer you need.

The ROCHESTER HELVE HAMMER is strongly made of first class material throughout. First grade hickory helve; exceptionally heavy anvil, giving greatest resistance to blow struck; steel base; long bearings for helve pivot. Fine for welding tires, work which cannot be done under most upright hammers. Dies can be furnished either lengthways or crossways of helve without additional cost, if specified with order.

Send for our illustrated catalogue free.

Makers of the Celebrated WEST HYDRAULIC TIRE SETTERS

### THE WEST TIRE SETTER CO.

ROCHESTER, N. Y.

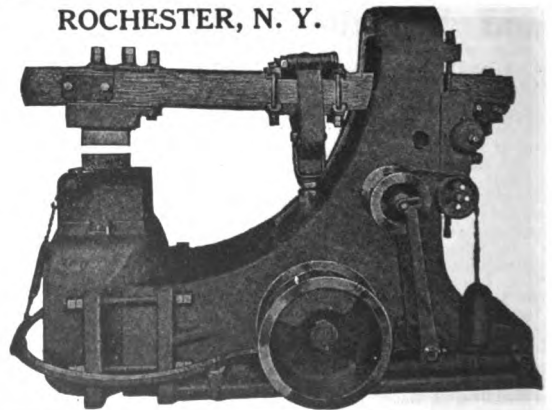



# Diamond Calks Stay in the Shoe

and don't fall out or pull out because the calk shank and the calk hole are made so absolutely accurate as not to vary  $\frac{1}{10000}$  of an inch in diameter.

In fact, they hold so tight that this heavy man suspended himself from a

## *Diamond Calk*

driven into one of our regular Diamond Shoes.

It would have sustained two or three men just as surely before coming out because the fit is so snug and uniform.

The remarkable hardness and toughness of our calks make them wear like a diamond and, because they *stay in the shoe*, insures the longest possible wear.

There's a Diamond Calk for every purpose.

Retailed only by horseshoers.

Ask for new catalogue and price list.

**Diamond Calk Horse Shoe Co.,**  
Duluth, Minnesota.

*Diamond  
Calk  
Shanks  
Fit at  
Every  
Point*

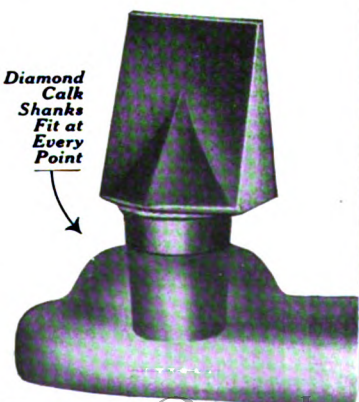



### A Money Making Line for SHOP OWNERS

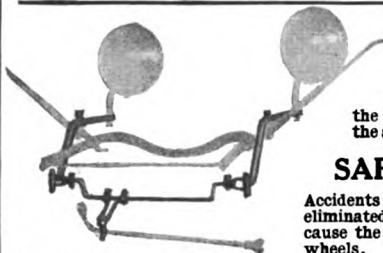

**Safety First Headlight Brackets for Ford Cars** are easily sold to every Ford owner. They turn the lights with the front wheels in the same direction that the car turns.

#### SAFETY ASSURED

Accidents due to turning dark corners are eliminated by the use of this bracket—because the lights are always ahead of the wheels.

Works in conjunction with the steering wheel. Adds to appearance of the car. Is quickly attached—uses the same lamps as before. **Price \$6.50.**

Send for sample today. Agents wanted in all sections—write for discounts.

**MOWERS MANUFACTURING CO.,** BOX 97, ST. CLOUD, MINN.

## THE FOOS

**1½ Horse Power Gasoline Engines.**  
Other small power sizes 2½, 4, 6, 8, 10 and 12 H. P.

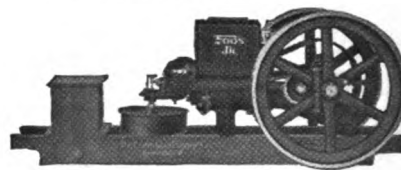

THE FOOS GAS ENGINE CO. SPRINGFIELD, OHIO

# WILLIS WELDER

Oxy-Acetylene Apparatus

Write for catalogue

**Henderson-Willis Welding & Cutting Company**

2305-7-9 No. 11th St. St. Louis, Mo.

## Wexford Motor Cloths



are noted for their long wearing qualities, their adaptability to all conditions and the ease with which they can be put on as a new top.

Wexford Cloth is woven of pure mohair combined with an absolutely waterproof fabric that is impervious to rain, snow and heavy dampness, and no ordinary folding will wear it out. This is a splendid proposition for you to take up. Write for samples and further particulars.

**L. C. Chase & Company,**

**Boston, Mass.**



If you have never learned by actual experience just how good **Pioneer Shaft Ends** are, do it now by ordering a few of your jobber, and don't let him pawn off on you the "just-as-good," "may suit" brand. Look for the Pioneer trade-mark on the wrappers. Possibly you order a certain kind of horse nails and shoes because they are better and please. So why not specify **Pioneer Shaft Ends** for the same reason? Once you get acquainted, they will be your affinity ever afterwards.

**Pioneer Shaft Ends** are the kind that are easy to fit, and make the strongest joint.

**THREE SIZES:—BUGGY, SURREY AND LIGHT BUGGY.**

Made by **CRANDAL, STONE & COMPANY, BINGHAMTON, N. Y.**

"First Made in America."

## Hay-Budden Solid Forged Anvils

HAY-BUDDEN MFG. CO., Brooklyn, N. Y.



**200,000 IN USE.**

Entire top being in one piece of high-grade forged steel, makes a loose face impossible.

## Safeguard Your Interests

by using Capewell nails. They give the best service and are most economical.

Shop losses come from wasting time and material. Avoid them by using this highest quality nail—

**"The Capewell"**

Best in the world at a fair price—quality considered, the cheapest.

**The Capewell Horse Nail Co.,**  
HARTFORD, CONN.

Leading Horse Nail Makers of the World











FEB 21 1918



