

This is a reproduction of a library book that was digitized by Google as part of an ongoing effort to preserve the information in books and make it universally accessible.

Google™ books

<https://books.google.com>

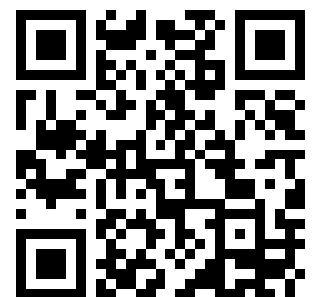



Vol. 18 - Oct 1918 - Page 7, 1918

7/P

AMERICAN BLACKSMITH AUTO & TRACTOR SHOP

VOLUME 18
NUMBER 1

BUFFALO, N. Y., OCTOBER, 1918

\$1.00 A YEAR
10c. A COPY

Entered as Second Class Matter at the Post Office at Buffalo, N. Y., under the Act of March 3, 1879



Horseshoers:
**You Can
Sell
Prest-O-Grip**

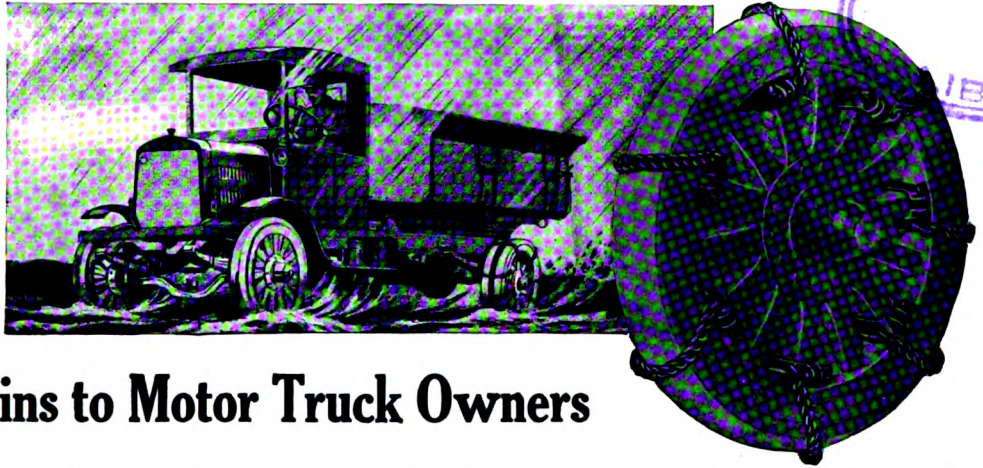

Anti-Skid Chains to Motor Truck Owners

MANY horseshoers are making more money in selling automotive equipment and accessories than in shoeing horses. Everybody knows that the use of motor trucks is growing—that motor trucks are displacing horses—but many horseshoers do not yet fully realize how phenomenal this growth is and to what an extent it is going to cut into their horseshoeing business unless they plan immediately to do business with truck owners as well as horse owners.



Prest-O-Grip
Anti-Skid Chains for Solid Tires



offer you a splendid opportunity to make money out of these changing conditions. Every motor truck needs an anti-skid device, and Prest-O-Grips are the leaders in the anti-skid field. They perform the double function of preventing skidding on a slippery surface and giving the tractive power necessary to enable the truck to pull through the deepest mud and snow.

WE HAVE ISSUED A NEW AND ATTRACTIVE BOOKLET ON PREST-O-GRIPS. Get this booklet and study the selling-possibilities of anti-skid devices. It will interest you. It will also prove an efficient sales-maker to give to prospects. A supply sent on request.

There Will Always be a Demand for ROWE CALKS—of Course

Horses are not going to disappear entirely—not yet awhile. And Rowe Calks will be sold everywhere there's a horse owner who seeks a good job of sharp-shoeing and wherever there's a horseshoer who wants to give it to him.

Rowe Drive Calks

When you put in a set of drive calks you want to be satisfied that they are going to wear and stay sharp. You can always have that satisfaction if you sell Rowe Drive Calks. We've given much study to hardening and heat-treating steel and we've put that knowledge into the manufacture of Rowe Calks. They represent the most advanced scientific ideas in calk-making today.

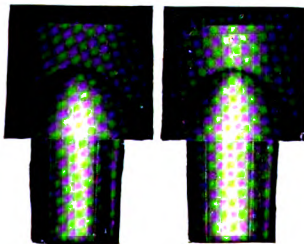

Rowe Ring Point "Golden" Rustless Calks

Rowe Ring-Points have revolutionized the screw calk business. The horseshoer who uses these calks is not likely to go back to wire pin calks. The hard center of Ring Points cannot become detached from the soft outside and fall out. This hard center remains intact and it stays sharp as long as the calks are in the shoe.



The Rowe "Fair-Deal" Policy is known to horseshoers generally. We sell Rowe Calks through Blacksmiths' Supply Houses only—not to retail stores, catalogue houses nor consumers.

The Rowe Calk & Chain Company
Plantsville, Conn.

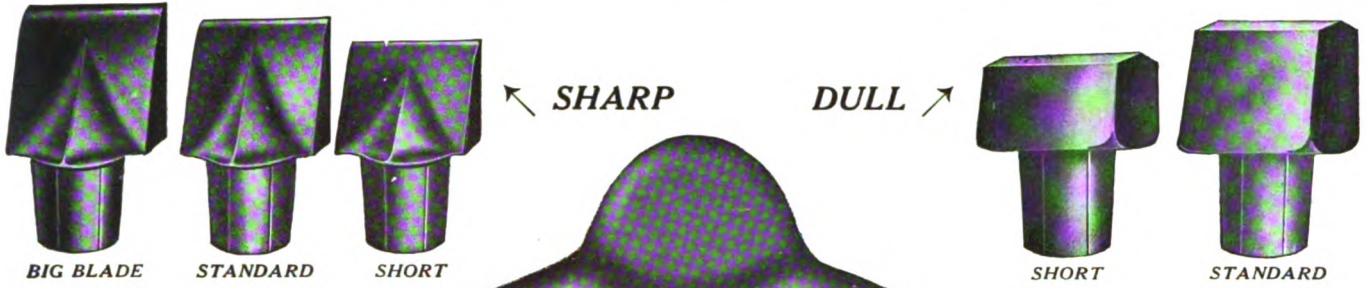

**WE
ORIGINATED**

the drive calk idea years ago and ever since we've been scientifically experimenting, developing and perfecting it until today the

DIAMOND LINE

stands unequalled in wear, fit, design and all-around efficiency.

DIAMOND SHOES are made for driving, draft horses and mules, from the very best horseshoe steel, and are the only ones guaranteed frost-proof. Their strong toe clips do not weaken the shoe. They're easy to fit and cost the least to prepare; nail-holes are well punched and properly placed; calk-holes have the deepest reinforcements and absolutely fit the calk.

DIAMOND CALKS, made from very high-grade tool steel, are tempered file proof. Practically non-breakable and have a chisel edge. Their ribbed shanks do not vary 1/10000 of an inch in diameter, which prevents their turning in the shoe or falling out. They are made Sharp, Dull, Block and Round in four sized shanks, different sized blades, and "There's a Diamond Calk for every purpose."

Ask for illustrated catalog and price list.

**Diamond Calk Horse
Shoe Company
Duluth, Minn.**

ROUND SHARP



STANDARD SHORT

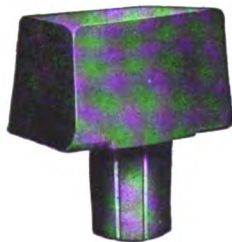

BLOCK

ROUND DULL

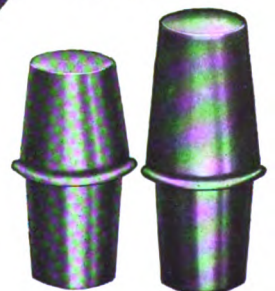

SHORT STANDARD

AMERICAN BLACKSMITH AUTO & TRACTOR SHOP

VOLUME 18

OCTOBER, 1918

NUMBER 1

BUFFALO, N. Y., U. S. A.

Established 1901. Published Monthly at the Sidway Building, Buffalo, N. Y., by the

AMERICAN BLACKSMITH COMPANY

Incorporated under New York State Laws.

WILLIAM F. WENDT, *President.*

WALTER O. BERNHARDT, *Editor.*

SUBSCRIPTION PRICE:

For \$1.00 per year, payable in advance, The American Blacksmith, Auto & Tractor Shop will be sent, postage prepaid to any postoffice in the United States. To Canada, \$1.25; to other countries, 6 shillings. Reduced rates to clubs of five or more on application.

Remittances may be made by money order, express order or checks payable to the American Blacksmith Company. We will also accept uncancelled postage stamps or currency, but for safety these should be sent by registered mail.

Subscribers should notify us at once of non-receipt of paper or change of address. In latter case, give both old and new address.

Correspondence on all smithing subjects solicited. Always give name and address, which will be omitted in publishing, if desired. Address all communications to the

"AMERICAN BLACKSMITH COMPANY"
BUFFALO, N. Y.

"Copyright W. F. Wendt Publishing Company, 1918."

Cable Address: "Blacksmith, Buffalo"



THE BIG "DRIVES"

Fourth Liberty Loan, Sept. 28 to Oct. 19.

Y. M. C. A. Campaign begins November 11.

Red Cross Roll Call Campaign, December 16.

If you were a soldier in the trenches, hearing the news from home only once in a great while you would wonder whether the folks back home were thinking of you and what part they were doing to see the war through to a speedy and victorious end.

When you buy a Liberty Bond the faith that the boys "over there" have in you to do your part is kept. The money that you loan to your country keeps our boys well fed and comfortably clothed, provides them with arms and ammunition and the means for transporting them overseas. Every dollar you loan to your country is a fighting dollar—if you can't fight yourself, let your money fight for you.

Your son, your brother, perhaps yourself, who knows, comes plodding along, burdened down with equipment, covered with mud and head down against a driving rain, dog tired, cold and hungry. He is making his comfortless way toward a light he sees in the distance. At length

he reaches his haven, a place of bright light, cheerful warmth, a hot and soul comforting drink, this is the Y. M. C. A. hut at the sign of the Red Triangle.

Give liberally to the Y. M. C. A. that it may continue its glorious work in providing rest and recreation for our boys. The Y. M. C. A. is not a glorified Sunday school. It is non sectarian and Jew and Gentile, Catholic and Protestant, black and white share alike the blessings and advantages of this splendid organization.

A battle is on somewhere along the 360 miles of battle line from the Channel to Switzerland and broken and bleeding men are borne or come painfully limping to the Red Cross dugout to receive the speedy and careful medical attention that assuages their physical agony or that will brighten the flickering spark of life in some quiet, palefaced, blood bathed soldier that he may be preserved to his country and his friends. This is the Red Cross.

Hundreds of men and women are daily risking their lives and no mention of them is given in the official casualty lists of the army. The splendid medical attention and sympathetic care that our wounded receive in Europe is due more than anything else to the splendid and untiring efforts of the Red Cross and its hundreds of devoted workers here and abroad.

The dollar that you give to become a member of the American Red Cross for a year will give you the assurance that you are helping to preserve someone's son or brother, if not your own. More than this, see that every member of your family becomes a member of the Red Cross when the time comes.

Giving to the Y. M. C. A. and the Red Cross is not a charity—it is a service that you owe to yourself and your fellow man

"He that giveth unto the least of these, my children, hath given unto me."

CONTENTS SEPTEMBER, 1918

| | |
|--|----|
| A Few Facts About Cone Clutches... | 3 |
| Hardening Clamp for Plow Lays.... | 4 |
| Spring Clip Repair..... | 4 |
| Ignition Timing and Valve Setting.. | 5 |
| Cutting Threads to Shoulder..... | 7 |
| How to Measure Spark Plugs..... | 7 |
| How to Make a Cold Chisel..... | 7 |
| Care and Repair of Automobile Starting and Lighting Batteries..... | 8 |
| Cold Weather Vaporizer..... | 9 |
| Storage Battery Sealing Compound.. | 9 |
| "Holder in Due Course" Can Enforce Payment of Note..... | 10 |
| Average Tractor Lasts Eight Years.. | 11 |
| Locating Cylinder Leaks..... | 13 |
| Steel Cleaning..... | 13 |
| Tearing Down, Repairing and Assembling Storage Batteries..... | 14 |
| Carburetor Adjustments of 20 Leading Cars | 16 |
| Making Your Own Distilled Water.. | 18 |
| Convoy Workshop Experiences in France | 18 |
| The Steel In Auto Springs..... | 20 |
| American Ideas Re-Made..... | 21 |
| Tightening Wrist Pin Bushings..... | 21 |
| The Army Horseshoer..... | 22 |
| Manufacture of Compressed Acetylene | 23 |
| Safety Break Pins..... | 23 |
| Sticking Valve Caps..... | 23 |
| Fuel Line Repair..... | 23 |

DON'T GIVE MONEY TO AGENTS

The American Blacksmith, Auto & Tractor Shop DOES NOT employ subscription agents. Any person representing himself as such is an impostor and should be so dealt with. Notify us immediately if anyone claiming to represent this journal calls upon you.

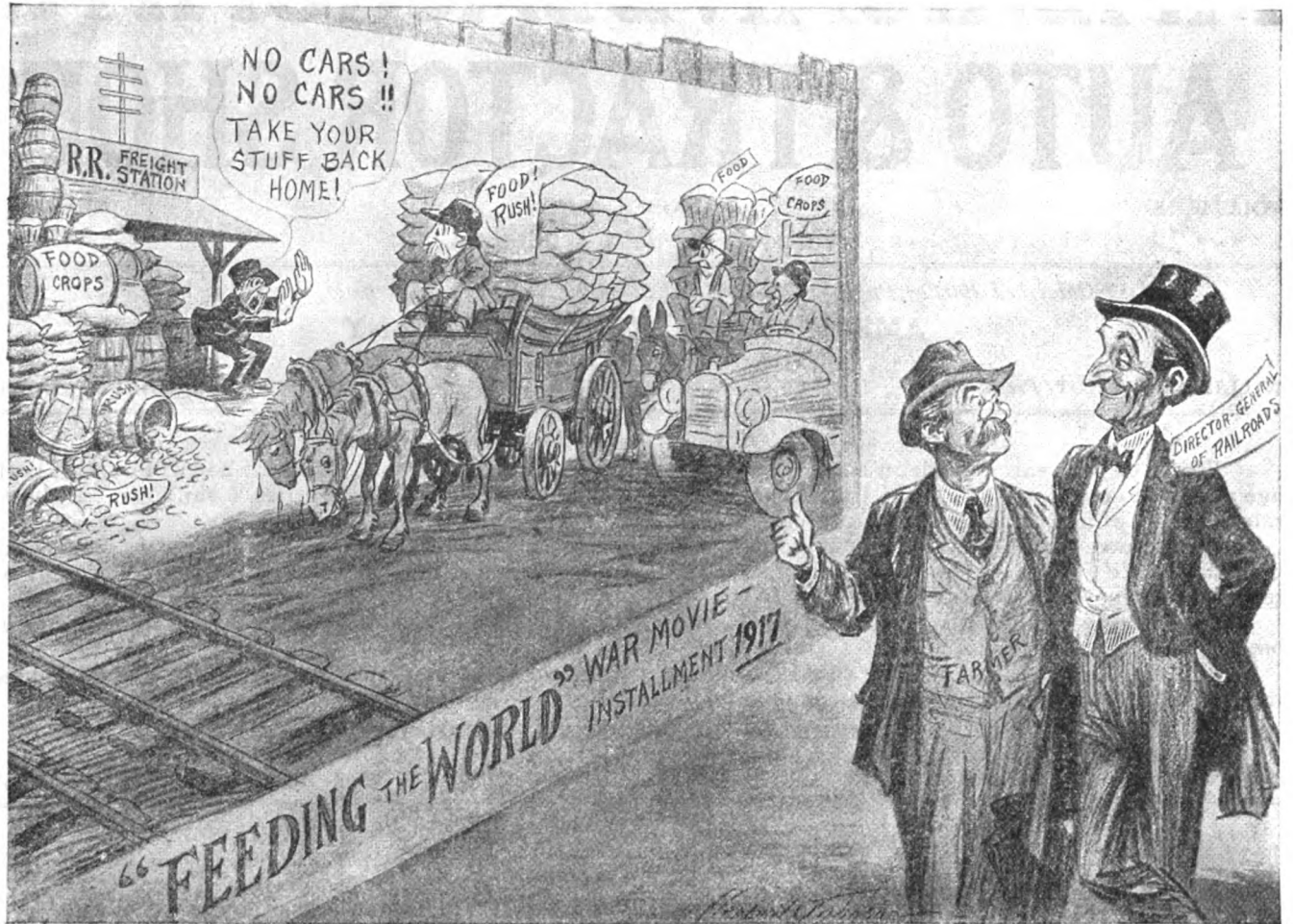

A Few Facts About Cone Clutches

J. L. HAKY

TWO kinds of clutches have been adopted as standard by American automobile builders; disk or plate clutches and cone clutches and it is with this latter style that this article has to do as a proper understanding of this widely used style of clutch and its

On the underside of the cone are five or six plunger studs having large, flat heads about the size of a 25 cent piece. The heads of these studs are between the clutch facing and the cone and springs serve to press these plunger studs outward and the heads of these serve

care must be taken to tighten one nut just as much as another.

If the clutch is too tight, it will drag and burn the leather. It should be just tight enough to hold under the heaviest load and yet release fully and gradually.

On some part of the frame back of the clutch is a clutch stop or clutch brake and this is designed to bring the rotation of the clutch to a quick stop upon disengagement. This stop is usually adjustable within limits of about an inch, forward and backward, and is fastened in place with two bolts.

Occasionally through someone's poor work the edge of the clutch gets battered up and when it is disengaged and drawn back against the clutch stop considerable noise is caused. This can be remedied by holding a coarse rasp against the edge of the cone while it is running.

Occasionally after considerable running, the clutch begins to "grab" and this is usually due to drying out or hardening of the leather facing. A dressing of the facing with neatsfoot or castor oil to soften up the leather will restore its easy and full engagement. The clutch may also grab because the rivets holding the facing onto the cone have come flush through the wearing down of the leather. Renewal of the rivets is a remedy in this case. These can be cut off from the back of the cone with a

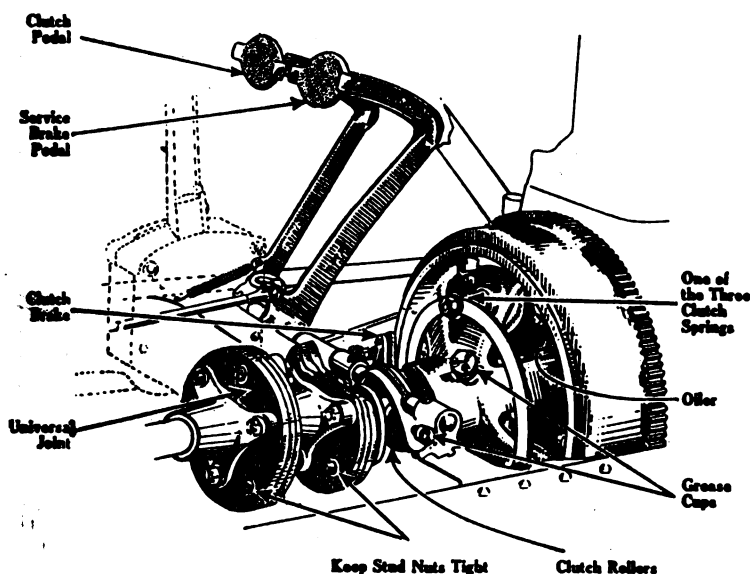

Clutch and its operation

care is of considerable value to the repairman.

Comparatively few automobiles are equipped with plate clutches, thus practically all cars with the exception of the Ford and Metz are provided with cone clutches. Overland, Oakland, Buick and a large number of other makes of cars are thus built with cone clutches and while most of the clutches of this style used on different cars vary in detail the principle is the same and the clutch equipment of the Overland car be considered as a typical example and it is this clutch that the writer has in mind and is used in the illustrations.

There are two styles of clutch cones, either of cast aluminum or of pressed sheet metal. The clutch usually has a leather facing on its outside circumference and occasionally other materials such as asbestos fabric may be used but in general a leather clutch facing is the standard.

to raise the leather slightly in places. These are provided to give a more gradual and smoother engagement of the clutch. It will not be found necessary to bother very much with these studs. However if it is necessary to loosen or tighten them up this can easily be done by screwing up the castle nuts that hold them in place.

The removal and replacement of the three rather powerful main clutch springs is best accomplished by means of two levers and a piece of stout wire as shown in the illustration.

A loose or slipping clutch may be tightened by screwing the three adjusting nuts down on their studs and

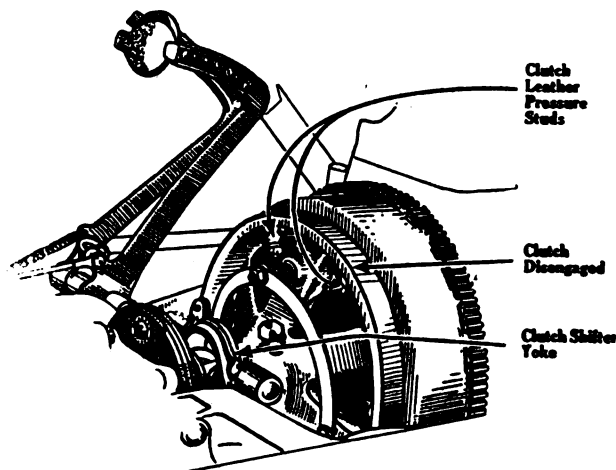

Clutch—disengaged

cold chisel and the rivet forced out by a punch. Occasionally the rivets may be sunk by using a center punch and driving the rivets in a trifle deeper.

Should the car pick up speed only slowly it is a sign that the clutch is slipping and should be tightened up as already mentioned, but not before it has been determined what is causing the slipping. There are several reasons for this; the clutch facing may be greasy, a little Fuller's earth thrown on the clutch facing will absorb the grease, or oil or it may be removed with a rag soaked in kerosene.

The clutch lining may be burned or worn down because the clutch has been allowed to slip too much in starting or speed changing. In this case a little neatsfoot or castor oil will set things right.

In no case permit lubricating oil to come into contact with the clutch surfaces. Do not attempt to make a slipping clutch hold by throwing sand into it, nor engage the clutch too quickly, trying to make it hold. Sand will destroy the pitch of the flywheel as well as the clutch leather and sudden engagement is apt to result in breakage of either the drive shaft or the universal joint.

Keep the clutch rollers and the universal joint well supplied with grease. When dry there is a tendency by these parts to make more or less noise and a dose of grease is the best cure.

There is an oil hole that leads down to the ball thrust bearing that is not shown in any of the illustrations but which may be easily reached with the oil can through the spokes of the clutch. Lubricate occasionally.

In cases where the rollers that

shift the clutch bind through lack of lubrication or other causes prob-

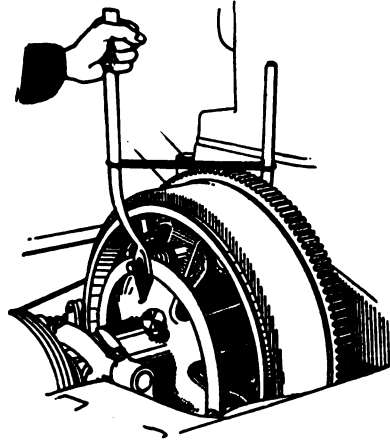

Removing clutch spring

ably the best remedy would be to replace them and to do this the whole clutch shifter yoke will have to be removed. It might be added that these rollers are placed in the shifter yoke with an arbor press at the factory and should be removed, if possible by the same means as it is possible that in endeavoring to drive them out that the yoke will be bent.

After all, the cone clutch is the simplest form of clutch and has the fewest number of parts to break and get out of order and they are generally easier to repair and get at than the disc or plate clutches and their serviceability and freedom from trouble is evidenced by the widespread use of the cone clutch in preference to other types.

HARDENING CLAMP FOR PLOW LAYS

The accompanying illustration shows a clamp that is a highly useful device when hardening plow lays to prevent warping when put into the water. Many smiths have difficulty in preventing this warping and the method in most general use is to bolt a piece of heavy tire to the back of the lay.

The construction of the clamp is made quite clear from the drawing and is built of two pieces of angle steel about $\frac{1}{4}$ by 1 inch and about 16 inches long. The "U" shape of

$\frac{1}{2}$ by 2 inch soft steel is riveted to the angle pieces and the hole in the bottom is threaded to fit the screw or handle as shown. Leave about $\frac{1}{2}$ inch opening between the two angles so that it can be slipped on the lay.

The handle is made of $\frac{5}{8}$ inch round stock and has a collar welded to it that presses against the top and threaded to fit the "U".

The clamp is applied in a line with the bolt holes.

Now, about heating the lay; Put the lay in the fire until it comes to a red heat and so that too much air does not reach it. Keep the top of the lay up in the fire and if the fire is not a large one keep the lay moving back and forth to get a

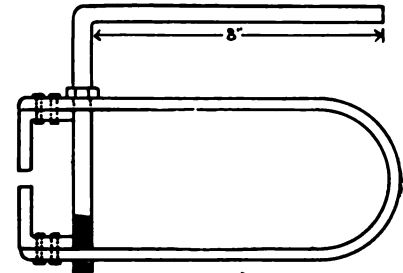

A CLEVER IDEA IN CLAMPS FOR PLOW WORK THAT PREVENTS WARPING OF THE WORK IN COOLING

uniform heat and keep coal on top of the lay. When the lay is hot, remove and place the clamp, screwing it down tightly. See that the lay is straight before applying the clamp and then cool off.

Robert Johnson, Nebraska.

SPRING CLIP REPAIR

Spring clips, especially in rough country, frequently give trouble by breaking and an effective repair can be made without difficulty in the manner shown in the illustration,

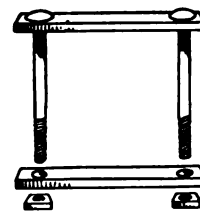

which consists of an overspring piece with a hole at each end, and two bolts of the proper size fitted through the holes. When this is fastened over the spring in place of the rigid one-piece clip, it forms a flexible spring clip which will withstand almost any strain.

OBSCURE TROUBLE

A persistent, irregular firing in the Ford has been found to be caused by the current jumping from the connections which project into the wood dash under the hood. Thick, hard rubber will frequently remedy this trouble.

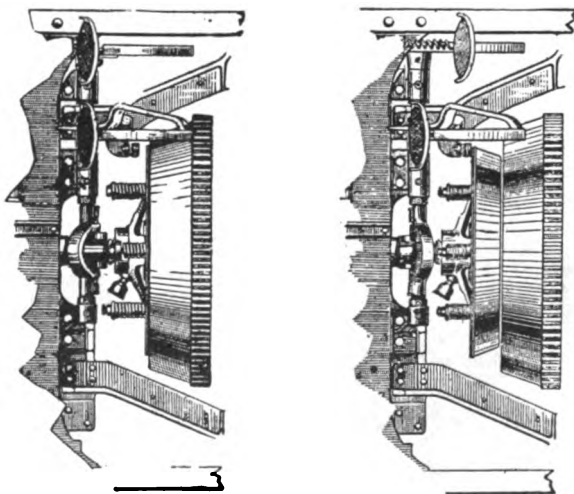

Exaggerated view of clutch engaged and disengaged

Ignition Timing and Valve Setting

VERMONT WELLS

The instructions for setting the timer on the Saxon Six Cylinder cars follow,—Crank motor until No. 1 cylinder has passed its uppermost position on the compression stroke one inch on the flywheel. This position can be located by the dead center mark (D.C.) on the flywheel. Move to position one inch past the flywheel pointer. No. 1 post on timer cap must now be in position to make contact with the

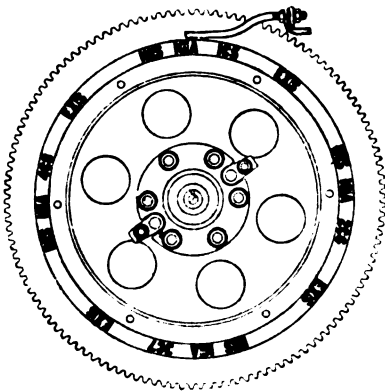

FLYWHEEL MARKINGS ON CADILLAC AUTOMOBILES

wiper. Rotate body of timer until contact breaker opens. Contact timer to spark control lever. Always set ignition with spark control lever in full retarded position. The firing order is 1-5-3-6-2-4.

To time the ignition on the Chevrolet, Model "F.A" cars, proceed as follows,—Loosen the two clamping bolts through the split collar on the generator housing and lift off the entire assembly. Remove the distributor cover and distributor arm, then with the special wrench, remove the lock nut holding the igniter cam to the shaft, slip the hooked end of the wrench under the cam and pry it loose from the shaft. Insert the starting crank and turn until the intake valve on No. 1 cylinder begins to open, remove the spark plug on that cylinder and insert a rod or piece of wire and continue to turn the motor until the piston has gone down and returned to its highest position. The piston is now on the top dead center of the compression stroke. This is also called the firing stroke. Now turn the cam on the igniter so that the driving pin assumes the position right opposite the place where the lever with the point begins hinges, now turn the cam to

the left until the points just begin to break. Now the lock nut can be slipped on the shaft and tightened on the shaft. Be very sure that the distributor is not moved. The distributor arm and cap may now be put in place and the car is ready for operation. The order of firing is 1-2-4-3, and the No. 1 wire is the one that is above the slot on the edge of the distributor. The igniter rotates clock wise or to the right, so you will see that after No. 1 wire comes No. 2, then No. 4, and No. 3.

The firing order of the Chalmers "Six-30", is 1-4-2-6-3-5, and in timing the piston in No. 1 cylinder should be at the top dead center, then the timer should be turned backwards until the interrupter points just separate. All upper dead centers are marked on rim of flywheel, thus—U.C.1&6, U.C.4&3, or U.C.2&5.

In timing the spark on the Dodge Brothers car, open all of the priming cups and turn the engine until the compression stroke begins in cylinder No. 1, you can tell when this is right by holding the thumb over the priming cup, and seeing that both valves remain closed at the top of the stroke. Continue to turn the motor over slowly until No. 1 piston has passed the top of the stroke about 5 degrees, which is about 5-8 of an inch past the dead center measured on the flywheel. This position can be found by turning the motor over with the crank until the exhaust valve is just closed in No. 4 cylinder. Take off the distributor head and rotor and loosen the breaker cam adjusting screw on the top of the vertical shaft. Now set the breaker cam in such a position that the rotor button will come under the position of No. 1 cylinder high tension terminal in the distributor head when it is replaced on the breaker cam, and so that the timing contacts are just starting to open with the spark lever in the fully retarded position. Set the breaker cam carefully so that when the slack in the distributor gears is rocked forward, the timing contacts will open and when the slack is rocked back these contacts will close.

To time the ignition on a 1918 Maxwell proceed as follows,—Turn the motor with the crank until the

No. 1 piston is 1-32 of an inch past top dead center or 1-4 inch past on the flywheel, this will be on the compression or firing stroke. Take the distributor cover off and turn the timer coupling shaft until the distributor arm is opposite No. 1 segment in the distributor cover. The front right terminal on the distributor cover is No. 1. Turn the timer coupling shaft to right or left until coupling pin is in position to engage in drive shaft coupling notch. While the timer is in this position couple it to the engine, bolt to the bracket and connect the terminals in the proper firing order of the engine, from left to right or clock wise, 1-3-4-2.

The firing order of the Chandler Light Weight Six is 1-5-3-6-2-4, and the exhaust valves are timed to close 1 5-8 inches past dead center on the suction stroke. The inlet valves open 1 7-8 inches past dead center on the same stroke. To find the top dead center, remove the pipe plug in the top of the flywheel housing under the upper floor board, then turn the flywheel until the mark on the flywheel comes opposite the marks on the case. When the marks are opposite one another No. 1 piston is at top dead center. To time the magneto, turn the motor until the No. 1 piston is at the top dead center on the compression stroke, then remove the oblong plate between the two poles of the

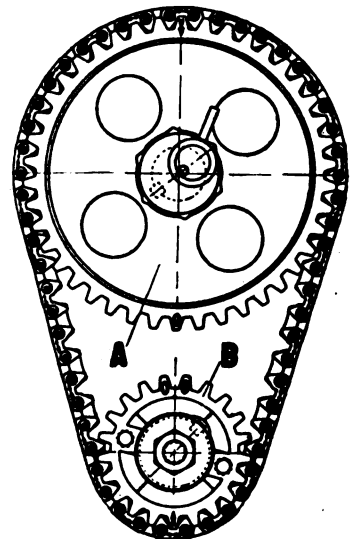

CAM GEAR MARKINGS ON CADILLAC. ARROW AND O ON GEAR "A" SHOULD BE AS SHOWN TOOTH MARKED O ON GEAR "A" MUST BE IN LINE WITH THE TWO TEETH MARKED O ON GEAR "B"

magneto, exposing the magneto armature, if it is properly timed, the armature will be half open. Should you need to change the

cold chisel and the rivet forced out by a punch. Occasionally the rivets may be sunk by using a center punch and driving the rivets in a trifle deeper.

Should the car pick up speed only slowly it is a sign that the clutch is slipping and should be tightened up as already mentioned, but not before it has been determined what is causing the slipping. There are several reasons for this; the clutch facing may be greasy, a little Fuller's earth thrown on the clutch facing will absorb the grease, or oil or it may be removed with a rag soaked in kerosene.

The clutch lining may be burned or worn down because the clutch has been allowed to slip too much in starting or speed changing. In this case a little neatsfoot or castor oil will set things right.

In no case permit lubricating oil to come into contact with the clutch surfaces. Do not attempt to make a slipping clutch hold by throwing sand into it, nor engage the clutch too quickly, trying to make it hold. Sand will destroy the pitch of the flywheel as well as the clutch leather and sudden engagement is apt to result in breakage of either the drive shaft or the universal joint.

Keep the clutch rollers and the universal joint well supplied with grease. When dry there is a tendency by these parts to make more or less noise and a dose of grease is the best cure.

There is an oil hole that leads down to the ball thrust bearing that is not shown in any of the illustrations but which may be easily reached with the oil can through the spokes of the clutch. Lubricate occasionally.

In cases where the rollers that

shift the clutch bind through lack of lubrication or other causes prob-

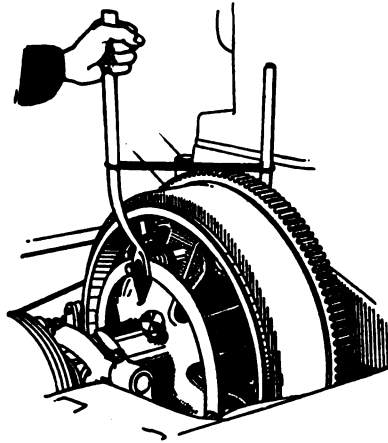

Removing clutch spring

ably the best remedy would be to replace them and to do this the whole clutch shifter yoke will have to be removed. It might be added that these rollers are placed in the shifter yoke with an arbor press at the factory and should be removed, if possible by the same means as it is possible that in endeavoring to drive them out that the yoke will be bent.

After all, the cone clutch is the simplest form of clutch and has the fewest number of parts to break and get out of order and they are generally easier to repair and get at than the disc or plate clutches and their serviceability and freedom from trouble is evidenced by the widespread use of the cone clutch in preference to other types.

HARDENING CLAMP FOR PLOW LAYS

The accompanying illustration shows a clamp that is a highly useful device when hardening plow lays to prevent warping when put into the water. Many smiths have difficulty in preventing this warping and the method in most general use is to bolt a piece of heavy tire to the back of the lay.

The construction of the clamp is made quite clear from the drawing and is built of two pieces of angle steel about 1/4 by 1 inch and about 16 inches long. The "U" shape of

1/2 by 2 inch soft steel is riveted to the angle pieces and the hole in the bottom is threaded to fit the screw or handle as shown. Leave about 1/2 inch opening between the two angles so that it can be slipped on the lay.

The handle is made of 5/8 inch round stock and has a collar welded to it that presses against the top and threaded to fit the "U".

The clamp is applied in a line with the bolt holes.

Now, about heating the lay; Put the lay in the fire until it comes to a red heat and so that too much air does not reach it. Keep the top of the lay up in the fire and if the fire is not a large one keep the lay moving back and forth to get a

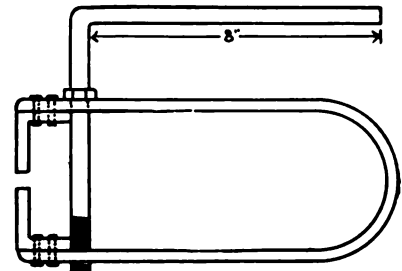

A CLEVER IDEA IN CLAMPS FOR PLOW WORK THAT PREVENTS WARPING OF THE WORK IN COOLING

uniform heat and keep coal on top of the lay. When the lay is hot, remove and place the clamp, screwing it down tightly. See that the lay is straight before applying the clamp and then cool off.

Robert Johnson, Nebraska.

SPRING CLIP REPAIR

Spring clips, especially in rough country, frequently give trouble by breaking and an effective repair can be made without difficulty in the manner shown in the illustration, which consists of a n overspring piece with a hole at each end, and two bolts of the proper size fitted through the holes. When this is fastened over the spring in place of the rigid one-piece clip, it forms a flexible spring clip which will withstand almost any strain.

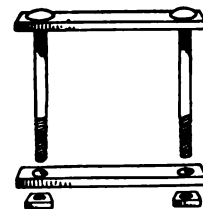

OBSCURE TROUBLE

A persistent, irregular firing in the Ford has been found to be caused by the current jumping from the connections which project into the wood dash under the hood. Thick, hard rubber will frequently remedy this trouble.

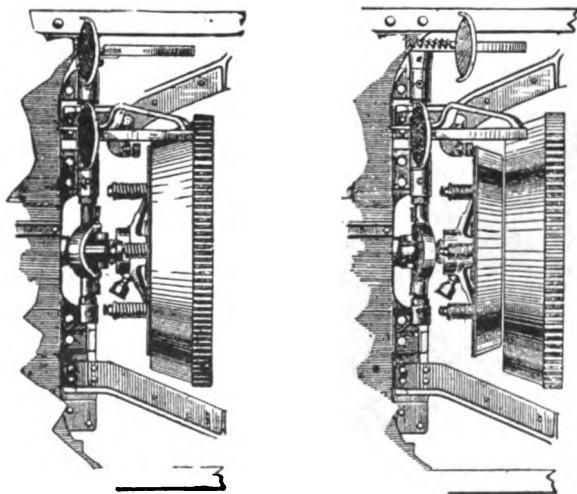

Exaggerated view of clutch engaged and disengaged

Ignition Timing and Valve Setting

VERMONT WELLS

The instructions for setting the timer on the Saxon Six Cylinder cars follow,—Crank motor until No. 1 cylinder has passed its uppermost position on the compression stroke one inch on the flywheel. This position can be located by the dead center mark (D.C.) on the flywheel. Move to position one inch past the flywheel pointer. No. 1 post on timer cap must now be in position to make contact with the

left until the points just begin to break. Now the lock nut can be slipped on the shaft and tightened on the shaft. Be very sure that the distributor is not moved. The distributor arm and cap may now be put in place and the car is ready for operation. The order of firing is 1-2-4-3, and the No. 1 wire is the one that is above the slot on the edge of the distributor. The igniter rotates clock wise or to the right, so you will see that after No. 1 wire comes No. 2, then No. 4, and No. 3.

The firing order of the Chalmers "Six-30", is 1-4-2-6-3-5, and in timing the piston in No. 1 cylinder should be at the top dead center, then the timer should be turned backwards until the interrupter points just separate. All upper dead centers are marked on rim of flywheel, thus—U.C.1&6, U.C.4&3, or U.C.2&5.

In timing the spark on the Dodge Brothers car, open all of the priming cups and turn the engine until the compression stroke begins in cylinder No. 1. you can tell when this is right by holding the thumb over the priming cup, and seeing that both valves remain closed at the top of the stroke. Continue to turn the motor over slowly until No. 1 piston has passed the top of the stroke about 5 degrees, which is about 5-8 of an inch past the dead center measured on the flywheel. This position can be found by turning the motor over with the crank until the exhaust valve is just closed in No. 4 cylinder. Take off the distributor head and rotor and loosen the breaker cam adjusting screw on the top of the vertical shaft. Now set the breaker cam in such a position that the rotor button will come under the position of No. 1 cylinder high tension terminal in the distributor head when it is replaced on the breaker cam, and so that the timing contacts are just starting to open with the spark lever in the fully retarded position. Set the breaker cam carefully so that when the slack in the distributor gears is rocked forward, the timing contacts will open and when the slack is rocked back these contacts will close.

To time the ignition on a 1918 Maxwell proceed as follows,—Turn the motor with the crank until the

No. 1 piston is 1-32 of an inch past top dead center or 1 1-4 inch past on the flywheel, this will be on the compression or firing stroke. Take the distributor cover off and turn the timer coupling shaft until the distributor arm is opposite No. 1 segment in the distributor cover. The front right terminal on the distributor cover is No. 1. Turn the timer coupling shaft to right or left until coupling pin is in position to engage in drive shaft coupling notch. While the timer is in this position couple it to the engine, bolt to the bracket and connect the terminals in the proper firing order of the engine, from left to right or clock wise, 1-3-4-2.

The firing order of the Chandler Light Weight Six is 1-5-3-6-2-4, and the exhaust valves are timed to close 1 5-8 inches past dead center on the suction stroke. The inlet valves open 1 7-8 inches past dead center on the same stroke. To find the top dead center, remove the pipe plug in the top of the flywheel housing under the upper floor board, then turn the flywheel until the mark on the flywheel comes opposite the marks on the case. When the marks are opposite one another No. 1 piston is at top dead center. To time the magneto, turn the motor until the No. 1 piston is at the top dead center on the compression stroke, then remove the oblong plate between the two poles of the

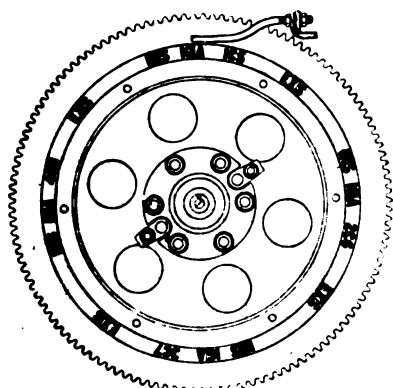

FLYWHEEL MARKINGS ON CADILLAC AUTOMOBILES

wiper. Rotate body of timer until contact breaker opens. Contact timer to spark control lever. Always set ignition with spark control lever in full retarded position. The firing order is 1-5-3-6-2-4.

To time the ignition on the Chevrolet, Model "F.A" cars, proceed as follows,—Loosen the two clamping bolts through the split collar on the generator housing and lift off the entire assembly. Remove the distributor cover and distributor arm, then with the special wrench, remove the lock nut holding the igniter cam to the shaft, slip the hooked end of the wrench under the cam and pry it loose from the shaft. Insert the starting crank and turn until the intake valve on No. 1 cylinder begins to open, remove the spark plug on that cylinder and insert a rod or piece of wire and continue to turn the motor until the piston has gone down and returned to its highest position. The piston is now on the top dead center of the compression stroke. This is also called the firing stroke. Now turn the cam on the igniter so that the driving pin assumes the position right opposite the place where the lever with the point begins hinges, now turn the cam to

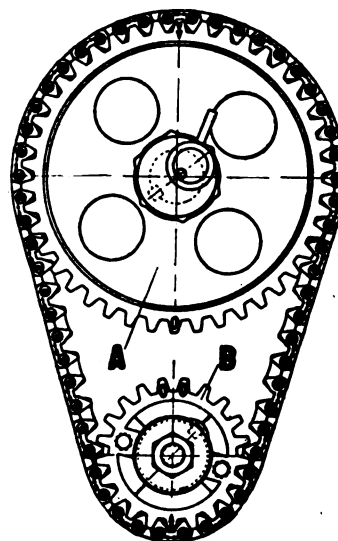

CAM GEAR MARKINGS ON CADILLAC. ARROW AND O ON GEAR "A" SHOULD BE AS SHOWN TOOTH MARKED O ON GEAR "A" MUST BE IN LINE WITH THE TWO TEETH MARKED O ON GEAR "B"

magneto, exposing the magneto armature, if it is properly timed, the armature will be half open. Should you need to change the

position of the armature loosen the lock nut which holds the magneto coupling, then loosen the magneto coupling by striking it a sharp quick blow. Now the magneto shaft may be turned, by turning the distributor at the rear of the magneto, after which tighten the coupling.

To time the ignition on a Chevrolet "Four-Ninety", proceed the same as on the "Six". The order of firing is 1-2-4-3.

To time the ignition on a Saxon four cylinder you do the same as on the Saxon Six and the firing order is 1-3-4-2.

To time the ignition on a Cole 8, proceed as follows.—Have the spark lever fully advanced on the steering wheel, turn the engine until No. 1 cylinder on the right side is within one and one-half inches of top dead center on the compression stroke. Loosen the timing adjustment screw in the center of the breaker cam and turn the breaker cam so that the rotor, when it is in place, will be under No. 1 high tension terminal in the distributor head, when it is in its place. The cylinders are numbered 1-2-3-4 on the right side and 5-6-7-8 on the left side, this will bring No. 5 as the front cylinder on the left side. The order of firing is 1-8, 3-6, 4-5, 2-7.

The following instructions for timing the spark will apply to the Studebaker Light Four, Light Six the Big Six, 1918 series 19.

First open the pet cocks on top of the cylinders and crank the motor with the hand crank until the piston in No. 1 cylinder has begun its compression stroke, this can be detected by holding the thumb over the pet cock. The upper dead center is indicated by the mark, UP-D-C-1 on the flywheel, before this mark comes in sight you will see a line marked AD-SP this means advance spark position. When this line reaches the pointer, stop turning the motor and place the spark lever at full advance position on the steering wheel. Re-

move the distributor cover, leaving the wires in place, lift off the revolving segment and loosen the nut which holds the cam on the tapered shaft. Pry the cam from its seat on the shaft, with the tool furnished, turn the cam to the left until it reaches a position, that when the parts are all in place the edge of the revolving segment will come directly under No. 1 distributor segment. Now continue turning until the breaker points are in the act of coming apart. Tighten the lock nut and replace the revolving segment and distributor cover.

To time the ignition on a Cadillac Eight proceed as follows.—Place the spark lever at the extreme left

when a point on the flywheel is one and twenty-one thirty-seconds inches in advance of the center line for No. 1 cylinder is directly under the pointer attached to the crank case of the engine. This point is marked for each cylinder on the flywheel by these letters, IG-A. If the spark occurs before this, turn the cam in a counter clockwise direction to correct this adjustment.

The firing order for the 1917 Locomobile cars is, 1-5-3-6-2-4. The magneto is set so that with the spark fully advanced the spark occurs while the piston is still 1-4 inch from the top of the cylinder on the "48" and 3-16 of an inch on the "38".

The battery breaker is set so to give the spark a little later than the magneto so that when the spark control lever is set at full retard the battery spark will happen after the piston has started down, this is so that it will be safe for hand cranking. If one has to re-set the magneto, turn the flywheel so that the piston in No. 1 cylinder is 3-16 of an inch ahead of the top dead center for

Notables On Vacation

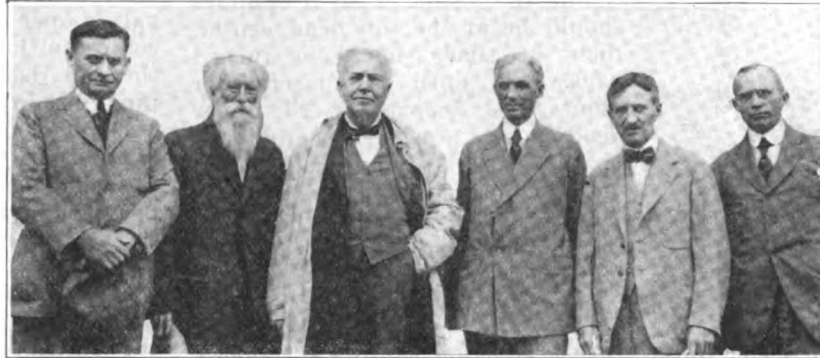

Reading from left to right; E. N. Hurley, Chairman United States Shipping Board; John Burroughs, America's venerable naturalist and author; Thomas A. Edison, the all round wizard of invention; Henry Ford, the wizard of industry; H. S. Firestone, tire manufacturer; Prof. R. L. DeLoach, Chicago's prominent educator.

The party gathered at Pittsburgh recently and went on a touring camping trip, roughing it for two weeks among the mountains and valleys of Tennessee, West Virginia, Virginia and the Carolinas.

of the sector, open the pet cocks and turn the motor with the hand crank until the piston in the No. 1 cylinder is on the firing center. No. 1 cylinder is the one nearest the radiator in the left hand block of cylinders. Now remove the distributor head and rotor, loosen the lock screw enough so that the cam can be turned by hand after the rotor is in place, now turn the rotor until the distributor brush in the rotor is directly under the terminal marked No. 1 on the distribute cover. Replace the distributor cover and move the spark lever to the right of the sector. Switch on the ignition and hold the high tension wire to the spark plug in No. 1 cylinder about one-eighth of an inch away from the cylinder casting and turn the engine slowly by hand. Stop as soon as a spark jumps between the wire and the casting. When the cam is in the proper place the spark will happen

the "38" and 1-4 of an inch ahead of the top dead center for the "48", this is on the compression stroke. The magneto armature should be turned by hand so that the distributor window shows that No. 1 cylinder is firing. Advance the spark lever on the magneto to full advance, when it is in this position, adjust the armature so that the breaker points are just about to open, then splice the coupling.

To time the N-U-4 magneto on an 1918 Metz car, turn the motor until the piston in No. 1 cylinder is 1-16 or 1-32 of an inch before dead center on the compression stroke. Now remove one of the brushes so that the slip ring can be seen, now rotate the armature shaft in the direction that it is driven, until the beginning of the metal slip ring segment is visible in the slip ring groove of the brush holder that has been removed, when this is done remove the cover of the

magneto interrupter housing to expose the interrupter, now rotate the armature shaft still further until the platinum interrupter screws are just about to separate, which occurs when the interrupter lever begins to bear against one of the steel segments of the interrupter housing. The armature should be held in this position while the magneto drive is connected to the engine. After this is done connect the cable of one of the brushes marked "1" with cylinder No. 1 and the other with cylinder No. 4, the remaining two cables leading from the brush marked "2" must be connected with cylinders Nos. 2 and 3.

CUTTING THREADS TO SHOULDER

Many a bolt head is twisted off because it would not screw in to the shoulder and this explains how it happens.

Cutting a full thread to a shoulder is impossible with any die. Each chaser of an automatic die or each land of the solid die can cut only its share and must have some chamfer in order to cut at all.

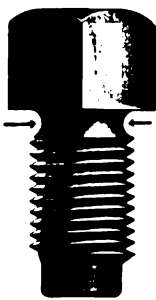

If it is necessary for the threaded part to turn in to a shoulder, neck out next to the shoulder to the depth of the thread for a space as wide as two threads as shown by the arrows in the illustration.

HOW TO MEASURE SPARK PLUGS

For reference and convenience in ordering we show here exact size cuts of the three leading sizes of spark plugs. The half inch Standard has a tapered thread measuring about 27-32 inch in diameter on the thread and has 14 threads to the inch. This size plug is generally used on all four cylinder motors. The Metric plug is 18 millimetres, or about 7-10 inch in diameter, and has 17 threads to the inch. Metric plugs are only found or used in engines manufactured in countries where the metric system is the standard of measurement. American made cars either when made for domestic or export use invariably use either the Standard or A. L. A. M. threads. The A. L. A. M. plug is 7-8 inch in diameter on the thread and has 18 threads to

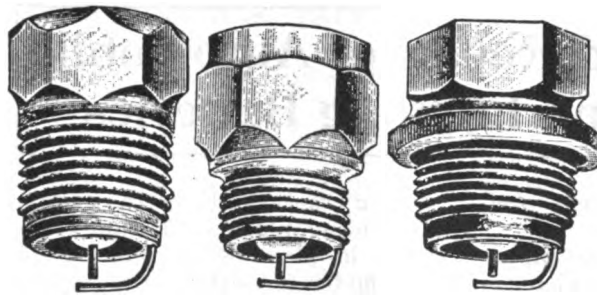

1/2-in. Standard Metric (French) A. L. A. M. (7/8x18)

THE THREE DIFFERENT SIZES OF SPARK PLUGS. THERE ARE VARIOUS STYLES MANUFACTURED IN EACH OF THESE SIZES FOR SPECIAL PURPOSES

the inch, and there is a shoulder 1 1-8 inches for the gasket. The 7-8 inch plug is used on practically all six, eight and twelve cylinder motors and on tractor motors.

WAR INVENTIONS

When this war began, Germany practically controlled the world's supply of potash. We have not only developed new potash fields in America. We have found a way to take potash from the flue dust of cement works, and we are now independent of the German potash supply for all time.

For years before the war, Germany was buying up the world's supply of castor oil and storing it for use in lubricating airplane engines. We have now perfected a mineral oil that serves as well as castor oil in all but the very fast fighting planes.

We have discovered a way to make coal smokeless by extracting from it valuable by-products that have previously gone to waste.

We have similarly found a way to save half the oils, greases and animal fats that have been lost in the past.

Put the Buckie Where He Belongs



FOOD WILL DO IT EAT LESS—SEND MORE ACROSS

We have recently produced a gas mask that can be worn for hours without discomfort even in a rapid advance.

We have introduced improvements in rifles and machine guns that give our soldiers weapons greatly superior to the enemy's.

New methods and appliances for fighting submarines have overcome the U-Boat menace. New industrial methods in shipbuilding have speeded up our production beyond all expectations. Improvements in wireless communication

have given our troops a great advantage on the battlefield. Improvements in medical science have reduced our army's death rate from disease to one tenth of the lowest rate established heretofore.

In short the nations whose inventive genius supplied the Germans with all their modern

engines of war, have now so improved on those inventions that the Germans are fighting at an increasing disadvantage on land, on water, and in the air. And civilization is proving its ability to defend itself from barbarism even when the barbarian is armed with weapons which he has borrowed from less backward people.

HOW TO MAKE A COLD CHISEL

When the chisel has been forged to the required shape the end should be finished by grinding or filing, and it should then be hardened and tempered. This should be done in one heat.

The edge of the chisel should be tempered to a deep plum color, verging on blue. The difficulty is that although the extreme edge may be of the correct tint, yet if the color is allowed to run down too fast the metal behind the edge will be too soft, will set under the shocks of the hammer and break. Then, again, if the color is allowed to run down too slowly the metal behind the edge will be too hard, and pieces will break off bodily.

The best way is to heat the chisel a very dull red for a good inch up from the edge, holding the tongs in the left hand and in the right a rub stone (a piece of broken grindstone or emerywheel, or, failing these, a strip of emery cloth wrapped round a small file). Dip the chisel for about half an inch until it just turns black, then withdrawing it from the water and letting it rest against the side of the pail, so as to steady it, rub it sharply with the stone or emery to brighten it, and watch the color as it runs down from the part which is still hot, and when the edge is of a deep plum color, verging on blue, quench it right out.

FROM FIRST TO THIRD

With most cars, particularly those equipped with a plate clutch, one may shift from first directly into high, in starting with a normal load on smooth pavements. The inexperienced driver should not attempt it, but the veteran will find that he can easily gain enough speed in first to make the shift directly into high without difficulty. Do not do it in heavy going or with a heavy load.

In the early days spark plugs were called "sparkling points."

In the infancy of automobiles a windshield was called a wind screen.

The Care and Repair of Automobile Starting and Lighting Batteries

Service Station Equipment and Battery Repairs

The following tools and apparatus will be found convenient in repairing, starting and lighting batteries; 1 pair rubber gloves to protect the hands from acid; 1 seven inch end cutting nippers for

burning rack with extra guides, for holding plates and connecting straps in place while burning; 1 hydrometer for mixing electrolyte; 1 thermometer for taking the temperature of cells; 1 lead burning outfit.

For burning plates into groups a

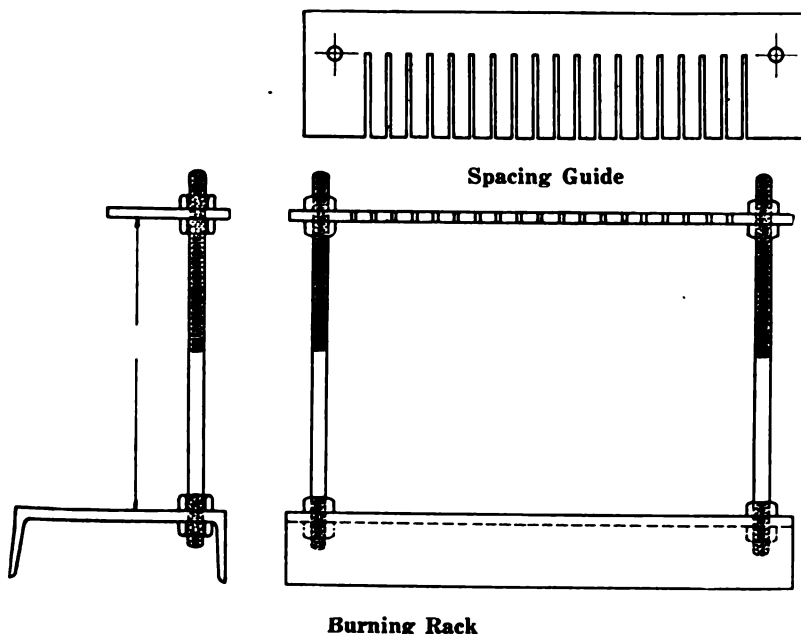

cutting connectors, posts, plate lugs, etc.; 2 combination pliers for pulling elements, etc.; 1 putty knife for removing sealing compound; 1 half inch wood chisel for removing sealing compound; 1 five inch screw driver for removing sealing compound and covers; 1 single end wrench for removing taper terminals; 1 ten inch coarse file and handle, for filing lead, plate lugs, etc.; 1 steel wire brush for cleaning terminals, etc.; 1 ball point hammer for general work; 1 ten inch ratchet brace, for drilling connecting links loose from pillar post; 1 five-eighth inch bit stock drill, for removing 5-8 inch connectors; 1 seven-eighth inch bit stock drill, for removing 7-8 inch connectors; 1 center punch for centering terminals to drill; 1 adjustable hacksaw frame for general work; 3 eight inch hack saw blades; 1 iron ladle for pouring sealing compound; 1 pair blue glasses for use when using lead burning outfit; 1 soft rubber syringe for flushing and equalizing electrolyte; 1 steel file brush for cleaning lead parts and file; 1

special rack is necessary for holding the plates and connecting straps in position while being burned into place and by reference to the accompanying illustration this device can be easily made from a piece of six inch channel iron which is used for the base, a couple of bolts and six or eight nuts. This rack can be made to suit any individual needs, the only set dimensions being in the top piece which is known as the spacing guide and which holds the plates and a set of guides should be made having the slots spaced as follows for different sizes and styles of batteries: 7-16 inch; 3-8 inch; 3-4 inch; 19-32 inch; and 5-8 inch. With a set of such guides one will be able to take care of any battery that comes in. The rack should be made adjustable for height as shown.

Charging Equipment—As recently explained, a lamp bank may be utilized for charging where direct current is available but this method is un-

economical and not practical where more than two or three batteries are to be charged.

The better method is to install a motor generator set. There are a number of different outfits of this kind on the market, information regarding which we will be glad to furnish interested parties.

Batteries MUST be charged with direct current and in making inquiry regarding charging equipment it should be specified whether current is direct or alternating. In either case the line voltage and the number of six volt batteries or total number of cells to be charged should be given, and where the current is alternating it is necessary to give the frequency (cycles per second) and whether single phase or three phase.

Lead Burning.—Lead burning consists of fusing component parts of the battery together by the use of a hot flame or a white hot carbon pencil. The most widely used outfits using a flame are as follows:

Illuminating gas and compressed air. The flame is synonymous with that given by the well known Bunsen burner. It is not a satisfactory flame for lead burning.

Hydrogen gas and compressed air. Where hydrogen can be obtained in tanks this is found to be a very satisfactory outfit, as it produces a hotter flame than that of the illuminating gas with compressed air, and where a great amount of work is to be done, it saves considerable time.

Oxygen gas and illuminating gas. This is the most satisfactory outfit, inasmuch as no compressed air is required, and commercial oxygen can be obtained practically throughout the United States. It is also very much more economical than hydrogen and air. The oxy-

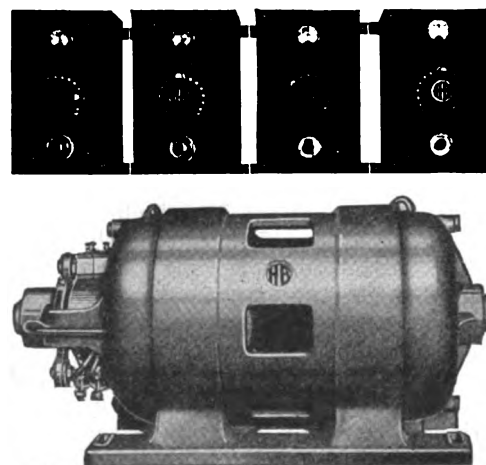

MOTOR GENERATOR SET FOR RECHARGING STORAGE BATTERIES

gen can also be used for removing carbon from gas engine cylinders.

Oxygen gas and hydrogen gas. This combination is not as economical as oxygen and illuminating

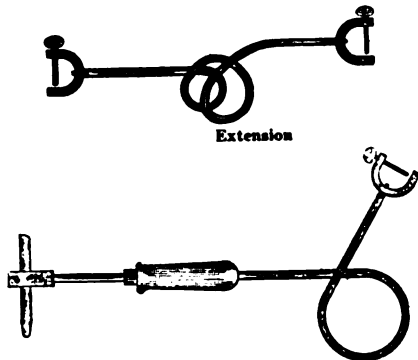

Extension

Arc Burning Outfit

gas, and the flame produced is much hotter and not suitable for lead burning.

For minor repairs a cheap and useful outfit is the arc burning outfit. This outfit can be used either

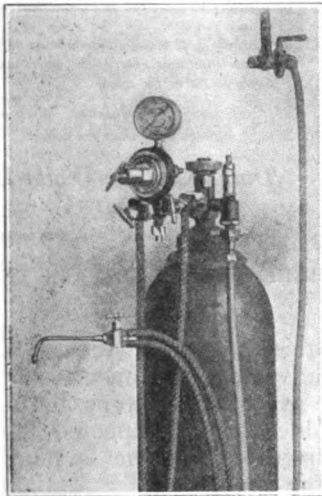

LEAD BURNING OUTFIT FOR USING COMPRESSED GASSES AND AIR

with the battery being repaired; or by using the extension, current from another battery may be utilized. The carbon pencil should be allowed to rest on the parts to be burned until it is white hot and then it can be used to melt the lead.

CLEAN EXHAUST SYSTEM

The wise owner will each year clean the exhaust system thoroughly. This cleaning around includes the exhaust manifold, pipe and muffler. The latter should be taken apart and the parts soaked in kerosene over night. The pipe and manifold may be cleaned by drawing through a pack of kerosene-soaked waste attached to a long wire.

COLD WEATHER VAPORIZER

A simple and easily made gasoline vaporizer that makes starting easy in the coldest weather is made of an old spark plug and a few inches of fairly fine iron wire or better, German silver (nickel silver) wire.

One end of the wire is securely attached to the outside of the metal shell and the other end is likewise attached to the inside spark electrode.

A hole is drilled and tapped in the inlet manifold just above the carburetor and the plug screwed in. A wire is run directly from the battery to the spark plug terminal with a suitable switch between. The outer shell of the plug being grounded, the wire coil becomes heated as soon as the current is switched on and the incoming air mixed with gasoline striking this heat instantly forms an ideal warm mixture.

This device can also be used to prevent water in the cooling system from freezing in cold weather by using it in one of the water pipes leading to the radiator. Of course to use current from the battery all night would soon exhaust its charge, but where electric current is available one of the small transformers that are largely in use for ringing door bells, and operating other low voltage electrical devices, could be used and the amount of current thus consumed would be negligible.

SOME TRICKS OF THE TRADE

That there are tricks in all trades none will attempt to deny; some of them are good and some are bad. It is the good ones which we here refer to. For example: Avoid getting too much color in the varnish-color, if you mix it in the shop. This condition does not give the best color effects nor bring out the normal brilliancy of the varnish. For black varnish-color four ounces of color in one pound of varnish will suffice to give the right proportions of mediums. Always thin the color with turpentine to at least a

cream-like consistency before adding the varnish. This produces a smoother, easier working material, and these proportions are such that the best surface conditions are obtained.

Sometimes the painter is in need of a varnish that will dry without gloss; have, in short, a rubbed varnish appearance. To get such a varnish dissolve four ounces of beeswax in turpentine and add to one quart of rubbing or finishing varnish, usually the latter. Never use a varnish of this sort without straining. As a matter of fact, all varnish-color should be strained to insure its cleanliness.

In fetching up a finish from the bare wood or metal make it a point to have all the puttying done upon one of the primary surfacing coats, preferably the second coat. The coat of roughstuff should be looked over carefully and all defects puttied. In this way get all the surface defects made good before the work comes to the color stage, at which point it is difficult to keep the putty from making trouble.

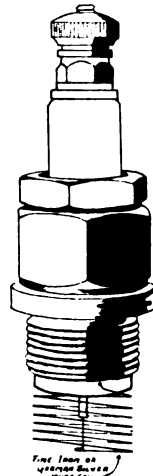

AN OLD SPARK PLUG AND A FEW INCHES OF FINE GERMAN - SILVER WIRE ARE ALL THAT'S NEEDED

STORAGE BATTERY SEALING COMPOUND

The water and acid proof compound that is used for sealing cells and surrounding jars of storage batteries is composed of 50 parts gum asphaltum, 25 parts paraffine wax and 25 parts of ordinary rosin, melted together.

Sometimes the composition around the top of the cells cracks and very often cause considerable annoyance. The best and simplest way to remedy this is to seal them together with a hot iron such as an old cold chisel or similar tool. Press the hot iron on the sides of the crack and gradually work them together until the hole is sealed up.

PROTECTING THE BREATHER

While the accepted function of the breather is to allow excess pressure to escape from the crankcase and also to offer an opening for the insertion of lubricating oil, this device also permits the entrance of a considerable amount of dirt and grit, which has free access to the bearings. It is a good plan to cover the breather with a piece of fine brass screen, which will exclude most of the foreign matter.

It's all right to extend the glad hand to a man in a wet town. But in a dry town a man would rather be offered about three fingers.

"HOLDER IN DUE COURSE" CAN ENFORCE PAYMENT OF NOTE

Ralph H. Butz

The goods which Jones bought from Smith did not prove to be all that Smith had represented them to be; so when the bank notified Jones that they held his note given in payment for these goods, he refused to pay it. The banker explained to him kindly but firmly that the note was "negotiable" and that the bank was the "holder in due course", and that he would have to pay it. His lawyer told him the same thing; so he paid.

Brown had an experience with another phase of the law of "negotiable instruments." When he sold some material to White and received a note in payment, he was afraid that White might not be able to pay the note; so he discounted it, thinking it better to

take these two steps. First, on the day the note was due they presented it to White, and demanded payment. When payment was refused, they notified Brown of this fact, and told him what they looked to him for payment.

has signed the note) or the endorser (who offers it to you) is able to pay it; and further, if it is offered in the regular course of business; if you do not know of any circumstances in connection with the giving of the note, or between the parties subsequently, which might be grounds for the maker to refuse payment; and if it is not yet due.

In other words, only a "holder in due course" can enforce payment against the maker, free from any defences to which the paper would be subject in the hands of the payee. A "holder in due course" must acquire the paper (1) before maturity, (2) in due course of business, and (3) without notice of any defects in title, or defences against the payee. That is, to consider these in reverse order, (3) the purchaser of a note must not be a party to a fraud; and (2) he will be considered such if he

take these two steps. First, on the day the note was due they presented it to White, and demanded payment. When payment was refused, they notified Brown of this fact, and told him what they looked to him for payment.

"Presentment and demand" must be made on the very day that the note is due. If due on a Saturday, Sunday or legal holiday, then on the next following business day. If the holder of the note overlooks or neglects this, he loses his right against the endorser. Second, on the same day, or the day following at the latest, notice must be sent to the endorser that payment has been refused, and that the holder expects the endorser to pay if the maker does not.

If the address of the maker or endorser is unknown, it is sufficient for the holder of the note to use "due diligence" in making presentment and demand, or in send-

DASH'S LIMITED, WAIMATE.

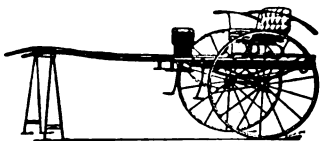

Three-Quarter Shaft Open Tray Gig.
Light Roomy Inexpensive.
Suits Pony or Horse.
RUBBER OR METAL TYRES.

DASH'S LIMITED, WAIMATE.

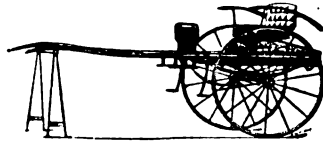

Same as Page 1
Plus Varnished Side Panels and Boot.
Warm, Neat, and Stylish.
LOW IN PRICE HIGH IN QUALITY.

DASH'S LIMITED, WAIMATE.

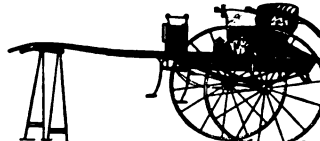

Three-Spring Gig
With Panel Body and Leather Boot.
Carries Three.
Handsome, Luxurious Vehicle. Rubber or Metal Tyres.

IN presenting these illustrations (from photos) of our own designs in standardised GGS, we are confident that the range offered is sufficiently wide to meet requirements. Of the six varieties here offered, the values are as widely varied as the styles.

The quality is guaranteed. Write us for latest quotations for what you desire.

Dash's Carriage Works Ltd.
WAIMATE

For anything on wheels. Buy, Sell, or Swap.

"BUY, SELL OR SWAP"—THIS ADVERTISING CIRCULAR COMES FROM AUSTRALIA WHERE THE FOLKS TALK LIKE REG'LAR YANKS

lose the discount than to run the risk of losing the whole amount. Before the note matured White went into bankruptcy.

The day after the note fell due, Brown received notice from the bank that the note had been presented for payment, and that payment was refused; and that the bank held Brown responsible for the payment. Brown told the banker that the note belonged to the bank and that they would have to look to White for their money. The banker then explained that the note was "negotiable", and that Brown as endorser was liable if the maker did not or could not pay. Brown's lawyer told him the same; so he also paid.

The purpose of the law regarding checks, notes and drafts, often spoken of together as negotiable paper, is to facilitate their circulation as money by making it safe to accept them. If you are offered a note for discount, or in payment of some indebtedness, you are safe in accepting it if you know that either the maker (who

acquired the note in any other way than in the regular course of business, or (1) after it has matured.

In the first case given, the bank would not have been a holder in due course if Smith had explained when offering the note that he was afraid Jones would not pay the note to him; or if Smith had kept the note until after it was due, and then had sold it to the bank or to another person; or if the bank had been told by Jones or by some one else that Jones had reasons for not paying the note. In any of these cases the bank could collect the note if Smith could collect; but they would have no better title than Smith had.

In the second illustration, the bank must take certain steps in order to hold Brown. The endorser is not liable under all circumstances to pay the note if the maker does not. He has what is called a contingent liability, which may be changed into an absolute liability if the necessary steps are taken by the holder of the note. The bank was of course careful to

ing notice. In such a case it is often advisable to consult an attorney as to what steps to take. The holder is not expected to do the impossible, but he is not excused for negligence.

To protect himself, Jones might have notified the bank and any other person to whom Smith might have offered to sell the note, that had a defence against Smith. Or, he might have signed a note which did not contain the words "order" or "bearer". If the note had read, "I promise to pay John Smith so many hundred dollars," it would have been non-negotiable, and if Smith could not collect it, then the bank could not, either.

In the second illustration, Brown might have protected himself by writing the words "without recourse" above his endorsement. Then the bank would have had no claim against him in case White did not pay. But the bank would probably not have accepted the note with this endorsement. Indeed, they might insist that his endorsement read, "Demand, no-

time and protest waived," in which case Brown would have been liable even if the bank did not demand payment on the day the note was due, or send notice of non-payment to Brown.

After Jones has paid the note, he still has a right of action against Smith for misrepresenting the goods; and when Brown pays the note he has a claim against White for the amount of the note, just as he would have had if he had not discounted the note. That is, payment of the note by the maker does not settle all claims arising out of the original transaction; and payment of the note by any party except the maker does not discharge the note. The purpose of the law is not to take away any of the rights of the parties to the note, but simply to make it possible for the note to pass from hand to hand by making both parties liable for its payment.

(Copyright, 1918, by Ralph H. Butz)

AVERAGE TRACTOR LASTS EIGHT YEARS.

The average life of a farm tractor is from 7½ to 8 years, according to estimates furnished by over 600 experienced tractor owners on representative corn-belt farms in Illinois. This is brought out in a study conducted in 1917 and the spring of 1918 by the United States Department of Agriculture, a report of which is published in Farmers' Bulletin 963. The reports of the tractor owners show that the outfits are used on an average of 45 days per year.

While at first glance this may appear low, when it is remembered that on farms where horses do all the work they are used on an average of only about 100 days annually, it will be seen that where both horses and tractor are used even though the number of horses is somewhat reduced, the machine need not be expected to have employment for as many days annually as did the horses. The horses kept will still do some of the work, which will, of course, decrease the amount to be done by the tractor. A considerable percentage of the 100 day's work done by horses represents odd jobs for which the tractor cannot be used to advantage. Even if the machine were to do all the work formerly done by the horses, it would not normally be employed 100 days per year, inasmuch as it does the work more rapidly.

It should be borne in mind, says the bulletin, that practically all

farm operations must be carried on within limited periods, and that between these seasons there will often be no field work which the tractor can do, either on the home farm or for neighbors. The fact that weather and soil conditions are such as to permit field work with a tractor does not necessarily mean that there is such work to be done. Farm management plays an important part in organizing the farm so as to provide profitable employment for the tractor during as many days as possible. Such organization involves the planning of a crop rotation which will furnish a large amount of work which it can do, the elimination of as many horses as desirable, and the distribution of the work over a long period. However, the rotation should in-

clude only such crops as can be grown profitably in that particular section.

The significance of the fact that a large percentage of the Illinois farmers who reported enlarged their farms, after buying tractors is readily apparent when the tractor's place in farm management is thus considered. Obviously these men have learned through experience that much more land per man can be handled when a tractor is used.

MAKING BRAKE ADJUSTMENTS

Do not get into the habit of making brake adjustments in one place. There usually are three or four places in the braking system and each adjustment should be used in turn.



"DEAD AHEAD" PREPARING THE LAND TO MAKE TWO BLADES GROW WHERE BUT ONE GREW THIS YEAR



THE RED TRIANGLE

Lift up the Red Triangle
Beside the thundering guns—
A friend, a shield, a solace
To our ten million sons!
Go build a hut or dugout
By billet or by trench—
A shelter from the horror,
The cold, the filth, the stench!
Where boys we love, returning
From out the gory loam
Can sight the Red Triangle
And find a bit of home.
Lift up the Red Triangle
Against the things that maim!
It conquers Booze, the wrecker!
It shuts the House of Shame!
Go make a friendly corner,
So lads can take the pen
And get in touch with mother
And God's clean things again!
Where Hell's destroying forces
Are leagued with Potsdam's crew,
Lift up the Red Triangle—
And help our boys "come through"!
—Daniel M. Henderson.

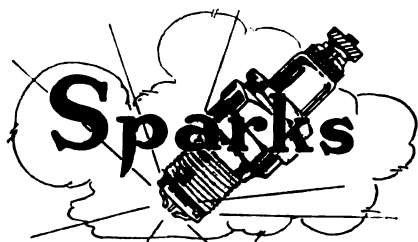

Twenty Years Ago Today

Ladies wore bustles.
Operations were rare.
Nobody swatted the fly.
Nobody had seen a silo.
Nobody had appendicitis.
Nobody wore white shoes.
Nobody sprayed orchards.
Cream was five cents a pint.
Cantaloupes were Muskmelons.
Milk shake was a favorite drink.
Most young men had "livery bills".
You never heard of a "tin Lizzie."
Doctors wanted to see your tongue.
Advertisers did not tell the truth.
Nobody "listened in" on a telephone.
Nobody cared for the price of gasoline.
Folks said pneumatic tires were a joke.
Farmers came to town for their mail.
The hired girl drew one-fifty a week.
The butcher "threw in" a chunk of liver.
Strawjacks were burned instead of baled.
People thought English sparrows were "birds."
There were no sane Fourths nor electric meters.
Jules Verne was the only convert to the submarine.
Pug dogs were considered nice pets.
They arrested people for "scorching" on bicycles.

Some hae meat and canna eat
And some would eat who hae no meat,
But we hae meat and we can eat
And sae the Lord be thankit.

— Burns.

Suppose the weather does spoil your plans. The boys over there don't always have ideal conditions for their job either.

One good deed begets another—Liberty Bond.

People who live in apartment houses shouldn't play trombones.

Other correspondents may forget to drop you a line every now and then. But it's different with the fellows that you owe.

The reason why son's actions make father so sick when son is in love is because father acted the same way himself when he was son's age.

Why is it that the man who has a neck like an elephant's leg always keep his head shaved?

If a boy tries to be a man he gets a lot of credit but if a man tries to be a boy we call him a darn fool.

Palmistry to the contrary, the lines on a man's face will tell you more about his past than will the lines on his hands.

One man is as proud of the fact that he can quit smoking as another man is of the fact that he has quit it.

What has become of the old fashioned house that had a big brass knocker in the middle of the front door?

According to a dispatch in the newspaper files of twenty-five years ago, "a carload of watermelons arrived in town and sold for ten cents each". That was twenty-five years ago.

If experience is as valuable as they say it is, why is it that most every man you meet is willing to swap about \$1,000 worth of it for a dollar?

Do your best my boy. But don't make a failure of yourself by trying to do better than you can.

When you say of a man that he is the sort of a fellow who gives more money to waiters than he gives to his wife, you have said a plenty.

Hindenburg can take his old line and join the kaiser in a warmer climate.

A newspaper headline tells us that an "American kills two Huns and captures nine." Some Yank.

And what has become of the old fashioned man who used his cuff for a notebook?

You can't paddle your own canoe by proxy.

Ever notice that when some men do you a favor they recall the fact every time they meet you for fear you might forget it?

Too much rain doesn't worry a farmer nowadays. It may ruin his crops, but he breaks even by hauling automobiles out of mudholes.

Our 'im of 'ate—Hev yez heard the news from Flanders? Bedad 'tis mighty tuff! They killed a million Germans there, But they didn't kill enough.

And if some fatheads didn't keep on talking about what they are going to do they would have nothing to talk about.

Looks like everything in the world comes right if we wait long enough.

A beautiful woman gets talked about; a pretty woman gets talked to; a homely woman gets talked at; the rest do the talking.

They tell us that the Bolsheviki are now eating bread made of straw. Now, all they need is to learn to bray and the transformation will be complete.

The next time you have a sore throat thank your stars you're not a giraffe.

The old fashioned reprobate who claimed that Heaven might have the climate but Hell had the company, wasn't figuring on having to associate with the Kaiser.

The man of mettle should know how to handle a bayonet.

Now the government asks us to save paper—what next?

At any rate there's no scarcity of shaving soap, there's just lathers of it.

One kind of bore that never proves to be a nuisance is a corkscrew.

The Lord will provide but the Food Administrator is still on the job, nevertheless.

The social climber demonstrates that many a boasted family tree is merely a creeper.

Don't rest on your laurels. An ounce of tomorrow is worth a pound of yesterdays.

It begins to look as though a lot of husky sporting editors would be out of a job inventing alleged sporting dope for newspaper readers.

One way to kill time is to talk it to death.

The wasp has a sting in its tail and so has malicious gossip.

Some people get up in the world and others are already on their uppers.

No, it isn't only in France that horses eat grass a la mowed.

The trouble with some people is that they believe one good turn deserves a better one.

"Dear Mary" wrote the farmer's wife to her married daughter in the city, "you wouldn't know the place at all any more. We got plumbing in the house, and a real bath room. And the place where the grape arbor was in the back yard isn't there any more, but is now a garage where father keeps his Ford."

If it is German propaganda which says that we are going to use the big fleet we are building for trade purposes after the war, it shows the usual German stupidity. Has anyone expected that we would burn and sink the fleet after the war?

Daughter steams her complexion in a Turkish bath nowadays; mother used to steam her's over the pots on the kitchen stove.

Hindenburg says the allies "eluded" him Gosh! Wonder what will happen to him, if he ever catches up with 'em?

Some loafers spend their lives sitting down and getting comfort out of the reflection that the last shall be first.

Love is great stuff; It will cause an ice man to get married even after he has seen the girls around the kitchen in the morning minus their makeup.

This is another damli—Once upon a time a man lost all his money and didn't lose most of his friends.

Some men are waiting for opportunity to come to them and ask them what they'll have to drink.

We never could understand how a colored man resists the temptation to vote under the rooster.

System is a winner in business but it won't beat the ponies.

The men who get the money are mighty sly on talk.

Labor is high and the laborer is worthy of his higher.

It hurts a man a heap more to be thrown down by a friend than it does to be held up by a friend.

Teach the young idea how to shoot and some day he may pot a Hun.

What has become of the old fashioned man who used to pull his fingers until his knuckles cracked?

TOUCHING UP "THE OLD BOAT"

NOW that we're going to have fewer new automobiles to go around it will be up to the old cars to "stand and deliver" until the war is won.

Naturally, second hand cars are going to be at a premium, in fact they are now. Automobile dealers a year ago were howling to high heaven about the "Used car situation" and their wails could be heard the length of the land; used cars were a drug on the market. Now all this is changed and automobile dealers are almost fighting to get hold of an old car.

To be sure a lot of the old timers that have been out of the factory a couple of years are more or less the worse for wear, depending altogether on how much care the original owner took of his car.

The enterprising auto dealer willing to spend a few dollars in fixing up battered tops, putting new lights in back and side curtains, new carpet on the floor board and filling out sagged and baggy seats and upholstering adds much to the selling price of an old car. All these things can be done at small cost and little labor and the results are really worth while in the added appearance and consequent value of the car for the used car is sold largely on its appearance.

ECONOMIZING IN TOOL STEEL

In the large plants it is recognized that the present price of tool steel demands that none shall be wasted, therefore it is used down to the last inch, by welding it to tire steel. Twist drills, taps, and reamers, when broken near the socket end, are welded and put into use again. For this purpose they use either the electrode or gas, but in both cases use vanadium steel filling rods, as these are found to give the best results in welding soft to tool steel.

LOCATING CYLINDER LEAKS

Often a small flaw in the cylinder casting will allow water to seep into the combustion chamber. If the crack is very minute it may not be perceptible to the naked eye, in which case it may be located by testing the casting with steam pressure.

STEEL CLEANING

Smear the object with oil, preferably petroleum, and allow some days

for penetration of the surface of the metal. Then rub vigorously with a piece of flannel or willow wood. Or, with a paste composed of olive oil, sulphur flowers, and tripoli, or of rotten stone and oil. Finally, a coat-

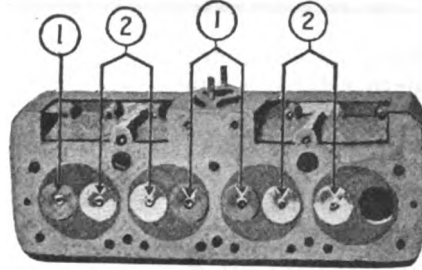

THE TWO OUTSIDE AND THE TWO INSIDE VALVES ARE USUALLY THE EXHAUST VALVES. THE EXHAUST VALVE HEADS ARE BLUED, THE INLET VALVES USUALLY BRIGHT IN ORDER THAT THEY MAY BE TOLD FROM EACH OTHER. 1—EXHAUST VALVES. 2—INLET VALVES

ing may be employed, made of 10 parts of potassium cyanide and one part of cream of tartar, 25 parts of potassium cyanide, with the addition of 55 parts of carbonate of lime and 20 parts of white soap.

SAVE TIN

The embargo recently placed on shipments of tin and tin ore from the Dutch East Indies by the Dutch government will inevitably cause considerable restrictions to be placed on the use of this important and widely used metal.

A great deal of the tin used in this country is obtained from the Dutch possessions and as our own country produces little or no tin, great economy will have to be practiced until the restrictions on shipments of tin are removed or modified by the Dutch government.

Great quantities of tin enter into the composition of so-called Babbitt metals and the effect of this embargo will no doubt be a sudden and considerable increase in the price of such anti-friction metals if it is possible to obtain them at all in their original composition. Hence, the genuine Babbitt composition, which contains little or no tin and are generally known as "lead base" metals will come into much wider application and the use of such "lead base" metals at this time is recommended as a patriotic duty.

ANTI-SCALE

The motorist may take a hint from steam boiler engineers, by mixing a little glycerine with the cooling water to prevent the formation of scale, in which capacity it is said to be very efficacious. The glycerine should be used in proportions of half a pint to each five gallons of water.

Benton's Recipes

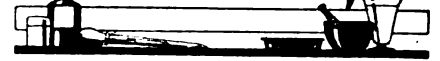

PLASTER OF PARIS FOR PATTERN MAKING

For experimental purposes and where but a few castings of medium and light weight are required, plaster of paris has many good advantages as a material for pattern making. It is light, it can be given a smooth surface, it is easily given any required shape and it can be added to indefinitely. While it is brittle, this is more than offset by the saving in first cost and the quickness with which the pattern may be prepared. Plaster of paris sets in from three to six minutes, but if for any reason it is desired to keep the mass plastic for a longer period, one drop of glue to a five-gallon mixture will keep it soft for a couple of hours. Plaster of Paris mixed with cold water has an expansion of about 1-16 inch to the foot when hardening. Should this be undesirable, mix with warm water or lime water and there is no expansion.

FASTENING SCREWS IN TILE AND BRICK WALLS

A simple way to fasten screws in tile or brick walls is to drill holes, not too large, with brace and bit, for the screws. Then tear up some paper, blotting paper is best, wet it and make a pulp. Pack this pulp tightly in the hole and turn in the screws. The screws will stand a great deal of strain. A little glue or plaster paris mixed with the paper pulp will make it even more effective—not so much as to make the screws become unremovable.

MAKING WAX IMPRESSIONS

It often happens that it is required in the manufacture of goods to make a wax impression of a sample or model. To do this successfully proceed as follows: Oil the surface of which the impression is to be made very slightly with a few drops of oil applied to a little waste. Then take common beeswax, melt it slowly, but do not boil it. Mix it with one or two tablespoonfuls of lamp black to half a tumbler of beeswax and stir the mixture. In order to make the wax impression show up clearly, take a fine hair brush and brush a little powdered graphite or rouge over the object on which the impression is to be made.

TO SHRINK HARD RUBBER

Some time ago the cap of my fountain pen had worn so loose that it frequently dropped off. I held it a few minutes over a hot stove with the open end of the cap downward, and was pleased to find that the diameter of the opening decreased sufficiently to cause the cap to fit the pen holder just right. I have used the pen several months since the experiment, and the cap is still all right. This idea may be used in other cases in which hard rubber is employed.

TO PUNCH HARD RUBBER

To punch hard rubber successfully heat the punch and die, or the material. The blanks usually curl or wrinkle into almost every conceivable shape in the operation of cutting. To straighten and bring them back to their original outline, allow the punching to drop into a pan of hot water. The action of the hot water causes the curled parts to return to their former flat position the same as before passing through the die.

How It's Done

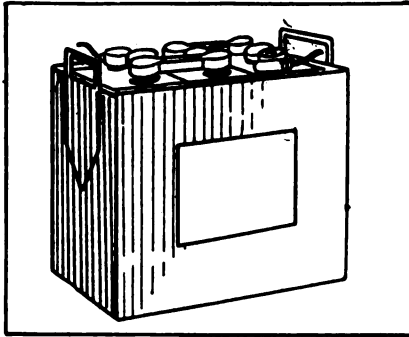

1—A 6 Volt 81 Ampere Hour Storage Battery used for starting and lighting. This battery was returned for repairs.

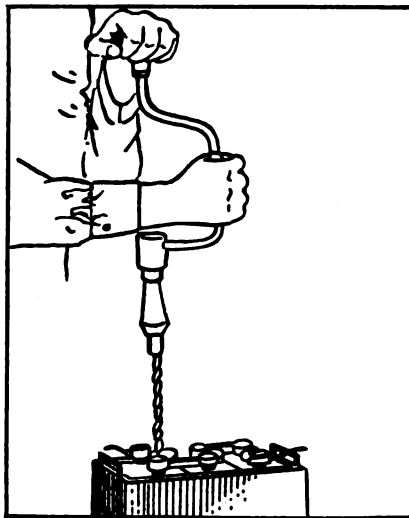

2—Before starting to dismantle a battery a sketch should be made showing the inter-cell connections and positions of terminals for guidance in reassembling. To remove terminal or connecting link, center punch the tops of terminals and connectors over the terminal posts and drill down to a depth of $\frac{3}{4}$ inch, using a $\frac{5}{8}$ inch drill for $\frac{3}{4}$ inch posts and a $\frac{7}{8}$ inch drill for one inch posts. Do not drill deeper than necessary so as to minimize the labor of building up the post again.

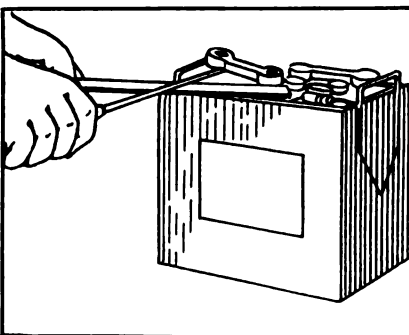

3—In removing the top connectors, place a file or flat piece of steel along the edge of the case.

Place an ordinary screw driver underneath the connector and pry it off. The object of the file or piece of steel is to protect the wood case from breakage.

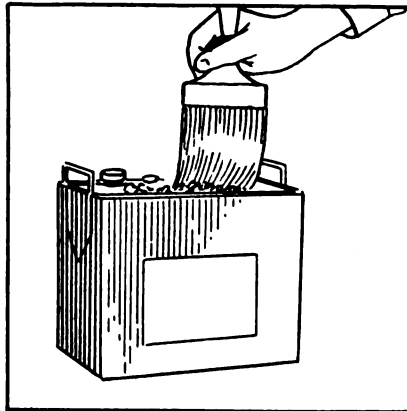

4—Brush off the accumulation of lead and dirt from the top of the battery. Care should be exercised to keep foreign substances from the inside of the battery, especially metal which may become lodged between the plates and separators and eventually cause short circuiting.

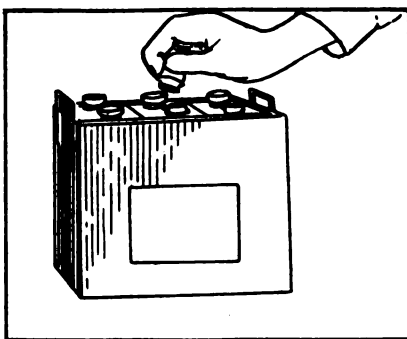

5—Unscrew and remove the vent plugs. In all cases be sure that the vent plugs are removed before using a flame around the battery. As hydrogen gas is generated in a battery its presence may result in an explosion. This gas can be quickly expelled by blowing into the cells with a bellows. As the vent plugs are made of hard rubber, which is easily broken, do not attempt to remove them with a pair of pliers.

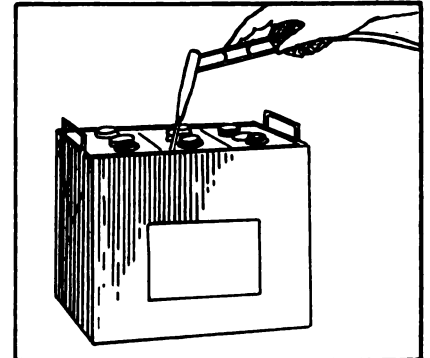

6—Soften the sealing compound around the edges of the covers by playing a gas torch flame over the compound. Care must be taken that the flame does not burn or scorch the covers. It is best to play the flame back and forth and not steadily in one place.

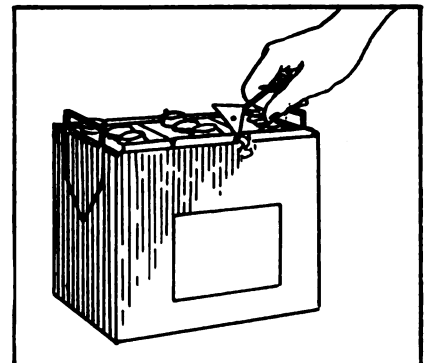

7—Using a heated screw driver, chisel or a plumber's lead scraper, dig out the compound around the edges of the covers.

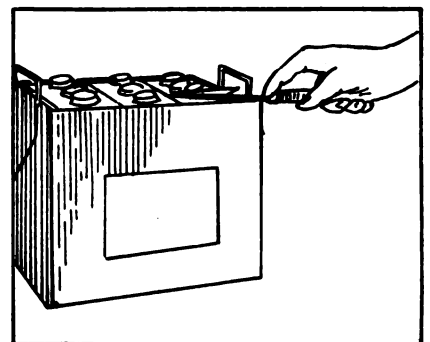

8—Again using a flame, heat the top of the covers to soften the underlying compound. Insert a screw driver under the covers and pry them off gently. Do not attempt to force them off but use more heat until they lift easily.

Tearing Down, Repairing and Assembling Automobile Starting and Lighting Batteries Part I

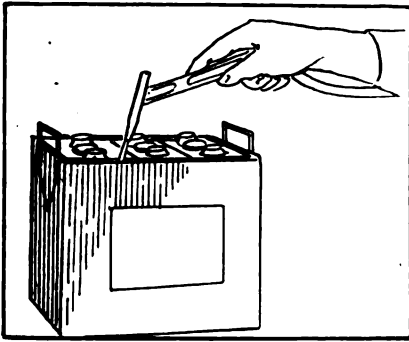

9—After the top covers have been removed, heat underlying compound with the illuminating gas flame or blow torch. Do not allow the flame to play in one place long as this would cause the compound to melt and run. A small flame used for several minutes will bring better results than a strong flame. After softening the compound it may be removed by using a heated screw driver.

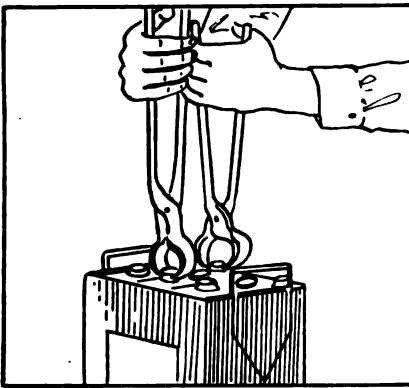

10—Apply the gas flame to the inside of the jar for an instant then run a hot putty knife around the edges between the jar and cover. Now place the battery on the floor,

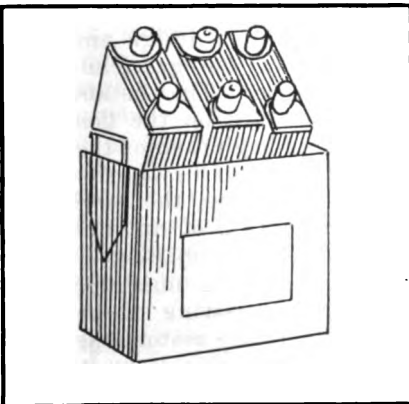

and holding it firmly between the feet, grasp the terminal posts with two pairs of pliers and lift the element and inside cover out together.

11—Let the elements rest at an angle on top of the jars to drain. While the elements are draining, apply a flame around the terminal posts and remove covers. The covers may have warped from the heat. If so, they should be placed in boiling water and flattened out on a smooth surface to cool.

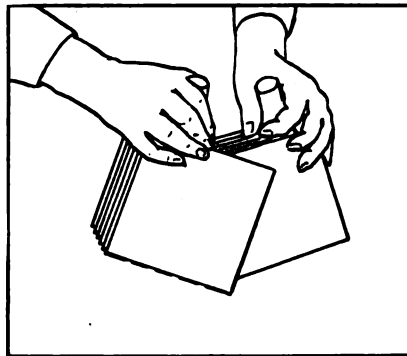

12—If separators are in good condition, and a jar replacement only is to be made, set the element, with bottom cover, in electrolyte or water till ready to replace.

If separation is to be renewed and plates examined, separate the positive and negative groups. Grasp the elements firmly and work the group back and forth.

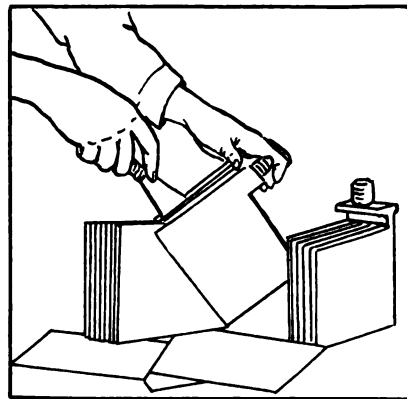

13—Remove separators. Take a putty knife and run it between the plate and the separator. It is always best to renew the separation. When a new battery is received for replacement of a leaky jar the

separators will generally be found in good condition so as not to require renewal. Separators should never be allowed to dry but should be kept immersed in water.

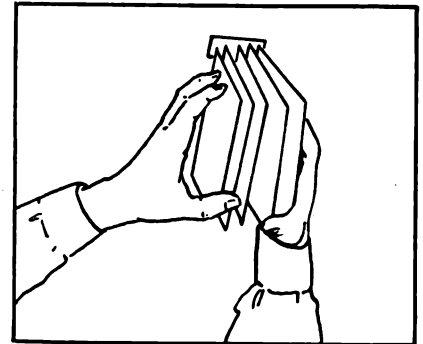

14—Plates should be inspected to determine whether or not they require replacement. If battery has been overheated through overcharging or short circuiting this will be indicated by brittle or buckled plates with the active material granular and falling away from the grid. Plates in this condition will have to be replaced. If electrolyte has not been kept well above the plates the tops of the plates will show a white substance known as sulphate. If the battery has been allowed to remain in a discharged condition for any length of time it will be indicated by sulphated plates. This sulphation is susceptible to removal by charge at a low rate for a long period. This rate should be about one half the normal charging rate continued until the specific gravity and voltage reaches a maximum value. Buckled plates if otherwise serviceable, can be straightened as follows:

Insert boards of suitable thickness between the plates and over each outside plate; place the pile in a vise, apply a gradual pressure exercising care that the plates are not subjected to severe strain.

The condition of the negative plates is sometimes such that they may be used again with new positives.

In this case the negative group should be immersed in water to prevent the plates from drying out through heating or exposure to the air. If the positive plate is fairly hard, and has not lost much of its surface, it may be used again. Occasionally it happens that one or two plates in a group require replacement while the balance of the plates are in good condition. In this case new plates may be used in replacement.

Carburetor Adjustments of Twenty Leading Cars

M. A. GEORGE

The Cadillac Eight, type 57, has a carburetor of their own make and should be adjusted as follows; Open the throttle about two inches on the sector at the steering wheel. Place the spark lever in the "Driving Range" on the sector and start the engine. If the engine is cranked by hand the spark lever should be placed at the extreme left on the sector. Run the engine until the water jacket on the intake pipe is hot. Move the spark lever to the extreme left on the sector and the throttle lever to a position which leaves the throttle in the carburetor slightly open. Adjust the air valve screw to a point which produces the highest engine speed. Turning the screw in a clockwise direction increases the proportion of gasolene to air in the mixture and vice versa. Close the throttle and adjust the stop screw to a point that causes the engine to run at about 300 revolutions per minute. The spark lever should be at the extreme left of the sector when this adjustment is made. Now with the spark and throttle levers at the extreme left on the sector adjust the air valve screw to a point that produces the highest engine speed. Open the throttle until the shutter attached to the right hand end of the throttle shaft just covers the slot in the carburetor body. Then adjust the screw to a point which produces the highest engine speed or to a point where the engine slows down slightly from a lean mixture. Turning the screw in a clockwise direction increases the proportion of gasolene to air in the mixture and vice versa. In very cold weather when a slightly richer mixture is needed it is best to turn the adjusting screw further in a clockwise direction.

The carburetor on the Dodge Brothers car is a Stewart and has only one adjustment, this adjustment changes relative height of the metering pin to the opening of the aspirating tube or spray nozzle when the dash control ratchet on the instrument board is in its regular running position. This adjustment is properly made at the factory and should not be changed

unless it is known for sure that it is wrong. The tapered metering pin is subject to control within fixed limits by means of the dash control ratchet located on the instrument board, for the purpose of obtaining a rich mixture for starting. Should there be any reason for changing the fixed adjustment of the tapered metering pin, it can be done by turning the stop screw to the right or left as desired. Turning this screw to the right lowers the position of the metering pin and allows more gasolene to be admitted to the spray nozzle thus

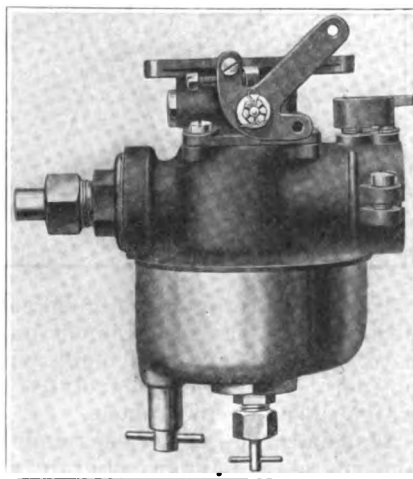

THE HOLLEY CARBURETOR IS A FAMILIAR TYPE ON SOME OF THE POPULAR PRICED CARS. THIS IS IT

enriching the mixture. Turning the screw to the left raises the pin, decreases the supply of gasolene and impoverishes the mixture. Bear in mind that a small part of a turn will make a difference in the amount of gasolene supplied to the carburetor and the action of it.

The Dort car has a Carter carburetor. This carburetor is automatic in its action and has no springs or valves to get out of order which is a mighty good feature. A choker is provided on the dash to allow the operator to obtain a correct mixture under all weather conditions. One should run the motor at all times, after it is warmed up, with the dash button pushed in as far as possible without loss of power. When the weather is cold it will be found

necessary to pull button out as far as possible, to aid in starting. As the engine warms up it can be pushed in until engine runs smoothly. The small knurled button on top of the glass float chamber governs the amount of gasolene supplied for acceleration or "get away." If the mixture is too rich turn this button toward "L". If too lean turn towards "H." Do not use this adjustment to regulate engine idling speed. If dirt should lodge on the seat of float valve, which controls the flow of gasolene into the float chamber, the valve will be held open and allow the gasolene to flood and leak out. With the blade of a knife, snap the knurled button up over the retaining ball, when it can be lifted off, exposing the upper end of the float valve. Turn off the gasolene. Lift float valve out with a pair of thin nosed pliers. The needle may be wiped clean and replaced. Never try to grind this valve into its seat. With the glass float chamber one can see the level of the gasolene, which should stand at just about the top of the copper float. A float level adjustment is provided to insure the proper amount of gasolene for acceleration. If the mixture is too rich the float level should be lowered. If too lean the float level should be raised. To adjust float level: Shut off gasolene at main tank. Loosen nut which attaches gasolene line to carburetor. Loosen needle seat lock nut. Turn needle seat until level is right. Tighten needle seat lock nut. Tighten nut which attaches gasolene line to carburetor and turn on gasolene. In making this adjustment it should be clearly understood, turning needle seat out raises the float level, while turning it in lowers the level. If the carburetor pops back with advanced spark, level should be raised slightly from this point. If mixture appears rich, it should be lowered slightly.

The Franklin car has a carburetor of their own design and make. The level of the gasolene in the float chamber. The distance from the bottom nut on the float valve stem to the beginning of the seat of the stem, should be $\frac{5}{8}$ of an inch. With this setting, the level of the gasolene is $\frac{1}{32}$ of an inch below the spray nozzle openings. Screwing the adjusting nuts up, lowers the level; screwing them down, raises it. If the motor starts hard and the carburetor seems to choke up and misses and the power is lacking may indicate that the auxi-

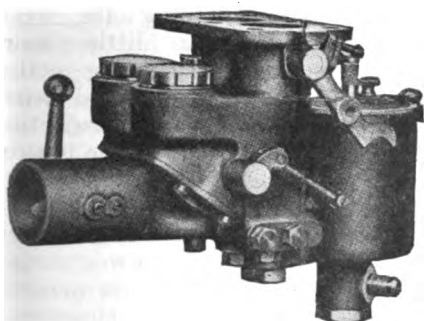

THE BALL & BALL CARBURETOR USED ON THE PEERLESS EIGHT IS OF THE DUPLEX MODEL, HAVING A SEPARATE VAPORIZING CHAMBER FOR EACH SET OF CYLINDERS

liary air valve needs adjustment. Be sure that the valve seats properly, and then change the tension of the spring acting on the valve stem lever by adjusting the screw to which spring is attached. Adjust so that when the engine is stopped or throttled down very slow, the valve will seat, but only so lightly that it will open as soon as the motor is accelerated. The needle valve is adjusted from the dash. For normal running the pointer on the needle valve handle should be at "D" on the dash. In this position the needle will be about one half turn open. Turning the handle clockwise closes the needle valve. This may not be the best position for every condition and the needle valve may have to be opened a little for starting and closed down after the motor is warm. Where one is taking a long drive in the country it is best to close the needle valve down until the motor will pop in the carburetor on quick acceleration. For slow running, quick pick up and extra high speed, the needle valve should be back to its normal position. There is an air adjustment for the carburetor on the dash. This will give hot air, cold air and no air or one of the various mixtures between these three. In cold weather, run with the lever at Hot; in hot weather, run with the lever at Cold. For hard fast driving, the lever should be at Cold, regardless of the weather.

The adjustment for the carburetor that is on the Maxwell car is as follows,—Set the dash adjustment in the center of the plate, loosen the binding screw on the carburetor needle valve handle and turn the needle valve to the right to its seat. Do not force. Adjust the needle valve to the left about three quarters of a turn, this will be more than is needed but it will start easy. Now start the engine, retard the

spark and close the throttle to the desired idling speed. When the engine is warm turn the needle valve to the right until the engine begins to slow down, indicating a weak mixture, then adjust in the opposite direction until the engine runs well.

Now open the throttle quickly — the engine should respond quickly, if there is a popping in the carburetor turn the needle valve to the left until this is overcome. The adjustment is now complete. Tighten the binding screw on the needle valve handle, so that the needle valve will not work out of adjustment. Any other adjustments that may be necessary can be made with the dash adjustment. In warm weather the amount of hot air to the carburetor can be regulated by opening the door in the hot air stove.

The adjustment of the carburetor on the Overland Light Four is as follows,—Run the motor until it is warm. Retard the spark to about one-third of the way on the quadrant and then throttle the motor until it is turning at about fifteen miles per hour road gait. Then turn the carburetor adjusting valve, which is under the carburetor, to the right until the motor starts to misfire, then open it slightly until the motor is firing regularly. Open the throttle quickly and if it pops in the carburetor, open the adjusting valve farther, until when the throttle is opened quickly there is no popping or skipping in the carburetor.

The carburetor on the Oakland Model 34, is adjusted as follows,—Start engine and let it get good and warm and then nearly close the throttle. Turn the needle valve a little at a time until engine runs smoothly, now to get the final adjustment, turn air valve screw to the left, releasing air valve spring, until engine begins to slow down. This indicates that air valve spring is too loose; turn air valve screw to right about one eighth of a turn at a time until engine runs smooth. Advance spark lever about one-half of its travel. Open throttle quickly and as far as it will go; the engine should speed up quickly. If engine does not and there is a popping in the carburetor turn needle valve a little to the left to admit more gasolene and then open throttle again. Continue doing this until the engine will speed up quickly and smoothly. The air valve screw should be adjusted so that the end of the screw is about even with ratchet set spring. The

needle valve should have a final adjustment of from five eighths to seven eighths of a turn. The needle valve has a T handle and is under the carburetor and the air valve adjustment is on the side and has a knurled nut with spring to keep it from turning.

The four cylinder Saxon car is equipped with a Riechenbach Atomizer and the adjustment consists of establishing a proper balance between fuel and air at all speeds and throttle positions. To accomplish this a thumb screw, which is on top of the carburetor, and a thumb nut which is at the bottom of the carburetor, are provided. The thumb screw controls the fuel openings. It is locked by a small screw. Turning the thumb screw to the right or clockwise increases the fuel feed, the reverse decreases it. The thumb nut provides a means for changing the tension of the spring, its movement to the right increases the tension of the spring and causes an increase in the fuel flow. The first adjustment should be made so that the valve controlled by the spring is slightly open, about 1/32nd. of an inch before the spring "takes hold". When the motor is not running the spring should be loose on its supports. If the mixture is correct for low throttle and weak on high throttle, loosen the thumb nut to the left and turn the thumb screw to the right. In adjusting either the thumb nut or thumb screw do not move more than one eighth of a turn at a time. There is a fine wire

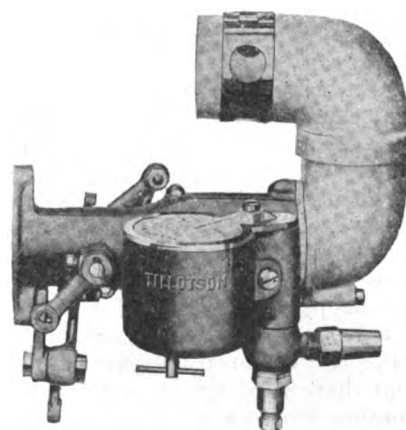

TILLOTSON CARBURETOR USED ON OVERLAND LIGHT FOUR MODELS

strainer in this carburetor that should be removed from time to time and cleaned.

The carburetor on the Peerless Eight is a fixed nozzle affair and the only adjustment is on the air valve spring which is controlled by

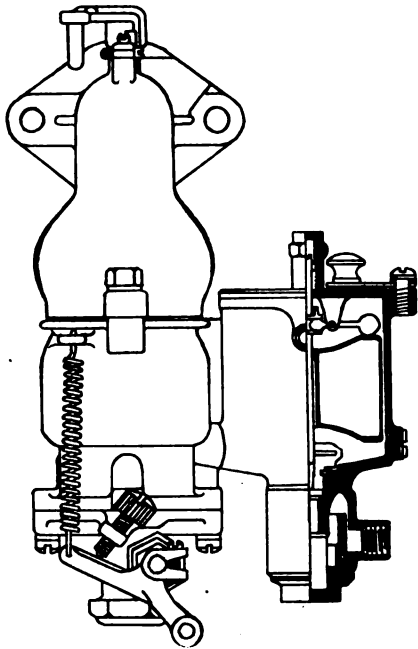

STEWART CARBURETOR

turning a cover at one side of the carburetor. The motor should be warmed up then disconnect one set of spark plug wires and screw the cover on the carburetor of the live set of cylinders. Adjust each side in this manner and then have both sides running. The idling adjustments can be slowed down some now, with both sides running.

The Packard people do not recommend having one adjust their carburetor as it is their own make. The auxiliary air valve can be changed and there is an adjustment on the dash to take care of the starting and the different atmospheric conditions.

There is a number of things that the garage man should observe before he moves the carburetor. See that there are no air leaks between the carburetor and the cylinder block or in the joints where the carburetor bolts to the manifold and where the manifold bolts to the cylinders. While the engine is running take your oil can and drop a few drops around the joint if there is a leak the oil will be drawn in. Take the carburetor apart and see that there is no water or dirt in the nozzles, use air to blow thru the nozzles to dislodge any particles. If water is found in the carburetor, open the sediment cup that is under the gasoline tank and you will usually find water there. Look at the ignition system and see that every cylinder is firing and that the valves are opening and shutting as they should. After one has looked over the rest of the engine and made sure that it is in shape

then, it is a good time to look at the carburetor.

It is best not to change the adjustments on the carburetor the first thing even then, is best to take it apart carefully and not change the adjustments, clean out the water and any sediment that may have gotten into the strainer. The garage man should have instructions for the different makes of carburetors where he can look them up as it will save him a lot of wasted time and extra labor.

MAKING YOUR OWN DISTILLED WATER

If you do not have clean rain water or distilled water handy, it is a very simple matter to distill a sufficient quantity of water for storage battery filling.

Illustration No. 1 shows a method which can be handled without trouble or extra equipment. Take an ordinary teakettle of aluminum or enamel ware (not iron or anything that will rust), attach over the spout a piece of hose, such as is used for watering the lawn and place the other end in a milk bottle or glass jar. This bottle or jar should be placed in a bucket or cold water.

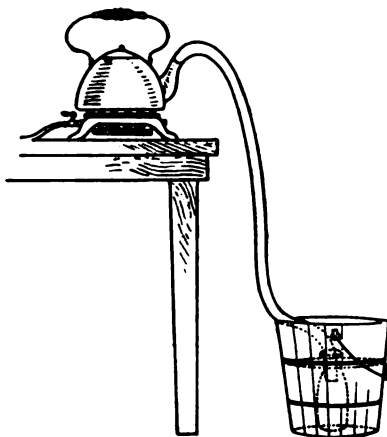

YOU COULD DISTILL YOUR OWN PRIVATE BRAND OF THIRD RAIL WHISKY THIS WAY TOO, BUT UNCLE SAM WOULD KICK

Enough cold water should be placed in the bucket to surround the bottle or jar to assist in the condensation of the steam. All apparatus should be absolutely clean and it is best to discard the first ounce of condensed steam as it may contain dirt from the hose or the kettle. By boiling the water in a kettle over any kind of a fire, the steam will naturally pass through the hose and upon condensation give the distilled water desired.

Illustration No. 2 shows an-

other way of doing the same thing and is a little more elaborate, the hose being coiled in a bucket filled with cold water or ice and the end projecting through a hole bored at the bottom

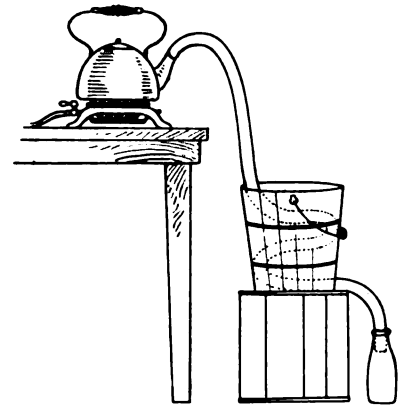

LOOKS ALMOST LIKE A "MOVIE" MOONSHINER'S EQUIPMENT

into a jar or bottle on the outside below. If there are any kinks or upward bends in the hose, these will fill with water and the steam will leak out around the cover of the kettle instead of going down through the hose.

Avoid using all iron fixtures or anything that will rust. Iron is especially injurious to storage batteries, and the distilled water should under no circumstances be allowed to come into contact with iron or rusty surfaces.

CONVOY WORKSHOP EXPERIENCES IN FRANCE

T. Northwood

THE time had now arrived when some of the engines were asking for a little attention, although up to this time this part of the cars had given us practically no trouble at all, so at every opportunity a car was brought in and received a general overhaul. The engines would be taken down and any play in the bearings was taken up, the valves re-faced on a lathe and ground into their seats, the tappets, springs and pushrods re-adjusted.

The whole chassis would receive a thorough cleaning. Spring bushings, shackles and all bolts showing signs of wear were replaced with new ones and the same plan was followed with the body, any damaged parts would be repaired, torn canvas patched and if shabby it received a coat of paint and finally the car would be taken out and tested and any additional adjustments were then made in the shop and the car was turned over to the

driver, who had remained in the workshop and assisted in the overhauling of his car, for further active service at the front.

I think this was an excellent thing for the drivers from an educational point of view as it gave them an opportunity to study the internal parts of the car and the functions which these parts had to perform and the result was that they made better drivers because they were able to handle their cars more intelligently than they could have done otherwise.

In the summer of the following year the question arose as to the best method to adopt to establish a heating apparatus from the exhaust for heating up the inside of the ambulances, so in my next article, for the benefit of anyone who anticipates installing an outfit of this kind, I will endeavor to show by illustrations the materials used and the manner in which the work was carried out.

ADVERTISING YOUR SHOP

The next time you take the wife and family to the "movies" for an evening's entertainment give some thought to the advertising slides that the operator throws on the screen while he is changing the pictures and think whether or not you would profit by advertising your shop in this way.

Winter is coming and with it long evenings that the whole community spend at the pictures. Most of the theater patrons in the smaller towns are owners of automobiles or other vehicles and agricultural implements that they possibly will have no use for until spring comes again and then you will be swamped with a rush of general repair work to be done in a few days time.

There is nothing "unethical" about blacksmiths advertising like there would be about doctors advertising their cures or their abilities.

Find out what sort of an arrangement you can make with your local movie manager to use your slide and you will be surprised at the low cost of such advertising. Think the matter over and invest a few cents in a lantern slide or, if you want us to give you any information about slides and their cost, write to us and we will be glad to give you all information on the matter.

You can't always get a loan out of a fellow because he looks lonesome.

HOW ECONOMY IN PAPER HELPS TO GAS THE HUN

Early in the war the Germans, with fiendish delight, invented poison gas and killed many brave British and French soldiers.

German newspapers said: "We are the greatest chemists in the world. We will win the war with our science."

It became necessary for the Allies to use gas, to even up matters.

Not long after we got into the war our chemists beat the German chemists at their own game. Our chemists have made gases for use in war that are far superior to the German-made brand.

Not long ago we put 500 Germans out of the fighting with one dose of our new gas. German army reports admitted that it was a deadly gas and more efficient than their own. Their boasted skilled chemists are unable to find out how to make it.

But all the world knows that one of its bases is sulphur.

There are but two sulphur mines in this country, one in Louisiana and the other in Texas.

In every sheet of paper that is made there is a certain amount of sulphur.

We have for years been wasting our paper.

There is not enough sulphur available to make all of the gas we want in carrying on our fighting against the inhuman Huns and also make the usual amount of paper.

We can get along with at least

one quarter less paper than we now use.

Every time you economize in paper, every time you do without a sheet of letter paper or a sheet of wrapping paper or paper bags—every sort of paper in fact, you are saving just so much more sulphur for our Government to put into war gases.

The more of this powerful gas we have at the battle front, the more of our boys' lives we save and the quicker we will win the final victory.

Do not waste a scrap of paper.

Do not use any paper unless it is absolutely necessary.

In this manner everyone, from the smallest child to the oldest person, can help win the war.

REPAIRING STORAGE BATTERIES

Beginning in this issue, on the two center pages, is the first of several illustrated articles on the tearing down, repairing and re-assembling of storage batteries.

This is the first time that such a thoroughly illustrated and comprehensive article on storage battery repairs has been published by any trade paper.

Storage battery repairing is an important and profitable business and, as you will see, it is a business that is by no means as difficult at it looks.

SQUEAKY RIMS

A wheel noise which may be best described as a crunch, is frequently caused by a loose wedge on a demountable rim. When replacing a rim it is advisable to go over all the nuts after setting them up tight.

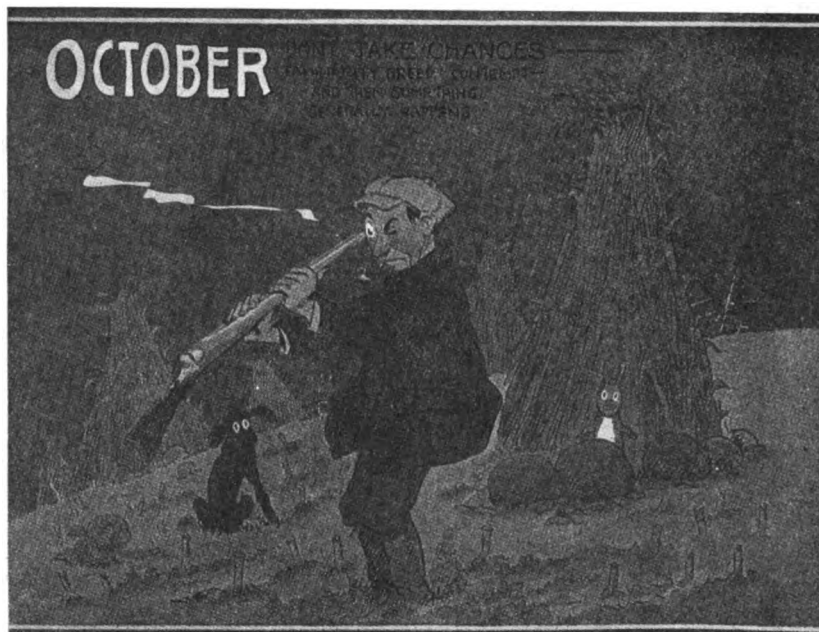

A LITTLE CARE WILL PREVENT MOST ACCIDENTS

The Steel That Goes In Auto Springs

The problem of making steel that will possess each one of the desirable properties to a maximum degree and the undesirable ones to a minimum degree requires the exercise of the utmost skill and knowledge at every stage of the process of manufacture, beginning with the choice of suitable ore. If we are to get even a rough notion of the difficulties here involved, it is necessary that we briefly outline the steps in the process of making and working steel.

Iron does not occur in a pure state in nature, but is always combined with oxygen. Indeed, pure iron is a metallurgical curiosity. It is clear white in color and must be kept in hermetically sealed containers to prevent it from combining with other substances, such as the oxygen of the air.

Iron is one of the most plentiful elements in the earth's crust. It occurs in different combinations with oxygen, each "oxide" having a technical name. The two most important oxides, or ores, are: Hematite, which is made up of two atoms of iron and three atoms of oxygen (in chemistry written Fe_2O_3); and magnetite, which contains three atoms of iron and four atoms of oxygen (written Fe_3O_4).

Other substances, such as sulphur, phosphorus, silicon, titanium, and manganese, are often present in the ore and these largely determine its value for certain purposes.

In order to separate the iron from the oxygen in it, ore, fuel (coal, coke or charcoal) and "flux" (limestone) are mixed in suitable proportions and charged into a blast furnace, which is built something like an enormous chimney. The fuel supplies the heat to melt the "charge," and the free carbon combines with the iron. The oxygen is mostly taken up by carbon and passes off as gas. The flux takes up most of the impurities and forms a "slag" that floats on top of the molten metal.

The molten iron from the blast furnace, when cast in moulds, is known as pig iron. It is saturated with carbon and may contain more or less of various impurities, depending upon the composition of the ore and the fuel used in the furnace. This iron is always extremely brittle and cannot be

worked into commercial form except by casting.

Before going further we should say just a word about carbon, because of its extraordinary effects upon iron. Carbon increases the strength, hardness, and brittleness of iron and makes it susceptible to heat treatment, whereby its structure and properties may be controlled with remarkable exactitude. Indeed, practically every technically important property of iron depends upon the amount of carbon present and upon the structural state of the combination between the two. We shall return to this later.

Steel is purified pig iron having a definite carbon "content," which may vary from 0.1 per cent. to 2.2 per cent. according to the use for which it is intended. The high-carbon steels are extremely hard

Put the Boche Where He Belongs



FOOD WILL DO IT
EAT LESS—SEND MORE ACROSS

and brittle and are very sensitive to heat treatment, while the low-carbon steels are tough, may be worked with a hammer (malleable), may be welded, etc., and are not as sensitive to heat treatment. Spring steel is usually chosen from an intermediate grade.

The process of making steel usually involves the melting of pig iron, treating it until practically every bit of carbon is burned out of it, and finally adding the exact amount of carbon desired, along with other elements which are used to improve the steel.

There are three main processes of making steel, namely, the Open-

Hearth, the Bessemer and the Crucible. Other processes are of far less commercial importance, although wherever the highest grade of steel is concerned, the electric furnace cannot be overlooked, as it is in a class by itself. In all these processes the object is the same, namely, to produce a metal of definite composition and as free as possible of occluded (absorbed) gases, and in general these ends are accomplished in all cases by adding materials which, by chemical reaction, will separate the impurities from the mass of the metal and permit their removal as slag or gas. Naturally that process which permits the most accurate control of the temperature, the ingredients, the atmosphere, and other conditions that enter into the operation, will produce the highest and most uniform grade of steel.

More than half of the total steel produced in the United States is made by the Open-Hearth process and a large per cent. is made by the Bessemer process.

In the Open-Hearth process the metal is melted in a long, shallow hearth by burning gases that are made to pass over it. It is a slow process, because all action takes place at the surface where the impurities are oxidized and absorbed by the slag and the carbon burned out as carbon monoxide gas. The only difference in the acid and basic Open-Hearth processes is in the lining and the slag, one being acid and the other basic. While the basic process also permits the removal of phosphorus and sulphur the acid process does not remove phosphorus or sulphur. Therefore, in this acid process the pig iron dare not contain an appreciable amount of these elements.

In the Bessemer process, molten pig iron is poured into a pear-shaped, rock-lined vessel called a "converter," provided with holes in the bottom through which a blast of air is driven and made to pass up through the molten metal and out at the top. This air, passing through the metal, first takes up the silicon and manganese, converting them into "oxides" which collect at the surface as slag; then the oxygen begins to extract the carbon in the form of carbon monoxide gas, which is blown out at the top and burns in a long, brilliant flame. All this takes place in about ten minutes. The result is a practically carbonless iron, and the temperature is much higher than before on account of the heat

released by the various chemical reactions. The next step is to "decarburize" the iron; that is, add the proper amount of carbon, manganese and silicon. The carbon gives it the desired strength and hardening qualities, the manganese takes up oxygen gas and sulphur, and the silicon absorbs other gases. Unless these gases are largely removed, the steel will not be fit for use.

On account of the speed of the Bessemer process, some steel makers use the acid Bessemer process to remove the manganese, silicon and most of the carbon, and the basic Open-Hearth process to remove the phosphorus and sulphur and the remainder of the carbon.

In the Crucible process, the iron, carbon and purifiers are placed in a closed clay or graphite crucible and heated with the practical exclusion of air and furnace gases.

The results with this process are better than with the ones previously described because of the more perfect control of the heat and the gases and also on account of the relatively small amounts of material handled.

The crucible process has the advantages of very slight action of oxygen, hydrogen and nitrogen as compared with either the Bessemer or the Open-Hearth process, but it usually involves a slight increase in the sulphur and phosphorous content. Phosphorous and sulphur are both very undesirable from the spring maker's point of view and partly for this reason it is desirable to make the highest grade springs from electric steel rather than crucible steel.

The electric furnace has the advantage over all other methods of not requiring the use of fuel and therefore no new impurities are introduced during manufacture. This, together with very active slag reactions and perfect control of the temperature permits a higher degree of purification of the metal than any other process. However, the electric process is expensive, and therefore, it is only used where the highest grade of steel is desired. Its principal practical use at present is to supplement the operation of the Bessemer and Open-Hearth processes by carrying the purification farther than would otherwise be possible.

Needless to say, the electric furnace offers by far the best means of producing spring steel because of the high degree of purity that can be obtained, and if we are to

get a steel with high dynamic resistance and non-fatiguing qualities it must be as free as possible from all impurities that tend to destroy the fineness, closeness and homogeneity of its grain.

AMERICAN IDEAS RE-MADE

John Y. Dunlop

A short time before the war a very interesting car was designed in this country (England) for the owner-driver in which the attention required was reduced to a minimum.

The best feature of the car perhaps, was the lubrication, there being no need to perform daily acrobatics to give a turn to multitudinous grease cups.

This is to be a British made car at a moderate price and which it is claimed will do everything but steer itself.



A gear box which will merely require the moving of a lever and single handler which will operate the jack and raise the hood

are some of the good things which are to be embodied in this car which is to be built on a large scale in an American type of factory after the war.

I think there is much need for some improvement in the details of some of those British cars, no matter where the idea is obtained from.

For instance, gear operating mechanism has not progressed as it should have done and there is a wide field for its improvement. There are many first class makes of cars which the ordinary man can never learn to handle properly. Gear Changers are more or less born, like poets, but that is all the more reason why gears should be designed as we are going to have in this new car.

Gear changing should be a mere matter of putting a lever into a certain position, not of clutch slipping and all such little tricks necessary to coax refractory gears into engagement.



AN AMERICAN SELF LUBRICATING SPRING WHICH HAS POCKETS IN EACH LEAF FOR THE LUBRICANT

American cars have generally easy gear changes and as a matter of fact the average American car can

give points to any car gear we have.

Another point to which not enough attention has been given in British made cars is lubrication.

The only way to maintain the internal friction of the spring as a constant is to have a lubricating system of constant efficiency. The simplest way of doing this is by an oil bath which, however, is out of the question for a leaf spring.

Perhaps the next best alternative is to have an initially greased spring packed externally with grease and enclosed in a grease proof case. With a screwed down greaser of adequate dimensions, pressure may be put on the grease which will force its way into every portion of the spring and remain there. If a case is not desirable each leaf spring should be drilled, pocketed and channelled so that grease from a screwed down greaser may be forced between all the leaves, continued pressure causing the grease to be forced out at the leaf edges and forcing all the dirt along with it.

Oil may be used as the lubrication medium on a similar system but whether grease or oil is employed the correct practice is to enclose the spring in a flexible covering so as to protect it from dust and other dirt and grit and to economize lubricant.

TIGHTENING WRIST PIN BUSHING

To tighten a loose wrist pin bushing when it is located in the connecting rod, take a piece of tubing that will just slip over the bushing on one side of the connecting rod. Next get a piece of metal a little smaller than the bushing to put against it. Put these in a vise and press the bushing out. Now give the bushing about a quarter turn and thrust it back in the connecting rod and you will find in the piston pin tight enough to run for some time before it will be necessary to renew the bushings.

CUTTING RIVETS

The proper tool to use in cutting out rivets that hold together thin metal parts is a sharp chisel. The head of the rivet should be backed up with a weight of some kind so as to prevent tearing of the adjacent metal. An oxyacetylene torch is the quickest method of cutting off rivet heads.

THE ARMY HORESHOER

Dry Feet—Dry feet frequently result from rasping the periople. Soften the hoofs by soaking in water and then apply cosmoline or linseed oil, which will retain moisture as the normal periople should do. This should be applied daily for a week or two. A thick paste of ground flaxseed and water, packed into the cavity of the foot between the branches of the shoe or a packing of moist clay will keep the foot soft. Such packings will generally remain in place overnight.

In this chapter have been treated the common foot ailments of the Army horse. Pathological shoeing for drop sole resulting from laminitis, for bowed tendons, and for other troubles that cannot be permanently cured has been omitted from this text-book. The Army

foot before turning the heels for preparing the bar, as the shoe is more easily fitted before welding the bar and the shoer can estimate the amount of stock required for making the bar.

To prepare the heels of the shoe before turning in the bar.

(a) **Scarfing**.—This is accomplished by holding the shoe on the face of the anvil (either surface on the face) and striking on the upper edge of the extremity of the heel, the hammer held at an angle of about 45° with the plane of the upper surface. This will result in a bevel between the upper and lower surfaces of the heel about a half inch in length. Scarf the other heel in the same way, except that the scarf is made on the opposite surface.

(b) **Pointing the Scarf**.—To insure a smooth weld. This is done

length of the finished bar, as the ends must overlap for welding. Turn the other heel in the same manner.

To Prepare the Bar for Welding.—Close the shoe bodily until the scarfed points overlap and then hammer the points down until they fit closely, leaving no space for coal dust to accumulate.

To Weld the Bar.—Place the bar in the fire and heat to a welding heat tilting or rocking the shoe forward and back to insure an equal heat on both sides. When the proper heat has been obtained (fluxing), place the bar on the face of the anvil and strike a few light blows on one point, then reverse the shoe and strike on the opposite point. This will bind the points together.

Reheat the bar to the welding heat and taking the same position

There's A Guy In Germany We'd Like To Show This Picture

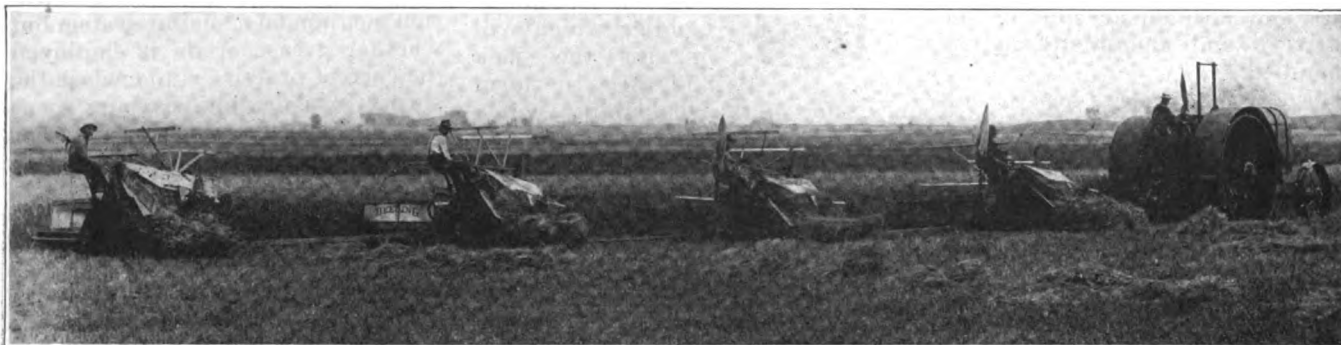

IN OUR MAY NUMBER WE SHOWED A PICTURE OF LOFFELMACHER BROTHERS' PLOWING THIS MINNESOTA FIELD AND HERE WE SEE THEM CUTTING GRAIN WITH A FOUR BINDER HITCH—LATER ON THE SAME TRACTOR WILL THRESH THE CROP. THE LOFFELMACHERS DON'T WEAR A UNIFORM OR CARRY A GUN, BUT WHAT'S THE USE—JUST LOOK AT WHAT THEY'RE DOING TO WILHELM DELIRIOUS HOHENZOLLERN AT HOME IN MINNOSOTA

horse must be ready for hard service. When his feet are incurably bad he should not be nursed but should be placed on the inspection report.

The Making of Pathological Shoes.—The Bar Shoe. This shoe, as previously stated, is more frequently required in Army shoeing than any other special shoe. It is made from the issue shoe, and the general fit and shape when finished are the same with the exception of the bar across the frog.

Select an issue shoe that is a size larger than the one that would ordinarily be used, and preferably a front shoe. A size larger in order that the heels shall be long enough to admit of turning the bar and a front shoe on account of its width and stock.

It is advisable for the beginner to fit the shoe to the outline of the

by holding each heel in turn so that it will rest at an angle upon the face of the anvil near the heel, and striking on the upper edge at the end. This is the same position and accomplishes the same result as pointing the heels of the plate and service shoes after drawing.

To Turn in the Bar.—Hold the shoe with the tongs at or above the toe; place the inside edge of the heel to be turned, on the point of the horn, the quarter nearly horizontal, with one inch or an inch and a half projecting over the horn, depending upon the length of the bar required.

Strike on the upper edge of the portion projecting over the horn, lowering the hand as the bend progresses, and turn in the desired length at a right angle.

The length of the bend should be a little more than one-half the

complete the weld by heavier blows reversing the shoe so that both sides will be flattened. After the weld is completed the bar is shaped by holding one corner on the point of the anvil and striking on the center of the bar, and then reversing. This will set the center of the bar forward, give it the correct shape at the heels, and prepare it for beveling. The front half of the upper surface of the bar must be hammered down (beveled) to the point, thus forming a cradle for the frog.

Fitting.—The bar shoe is fitted as is the service shoe, and the same heats are used. A little more allowance, however, is made for expansion on account of the added frog pressure.

To Open the Toe.—The shoe is heated throughout to an even heat and held upright with the bar on

the face of the anvil. The blows are struck along the toe, thus opening the toe and quarters without changing the bar.

The toe may be opened as in the service shoe.

To Widen the Heels.—By lengthening the bar.

When the Quarters are too Long.—Heat the bar and the heels to a cherry heat. Hold the shoe in the tongs at the toe and place inside edge of the heel on the point of the horn, resting at the point from which it is desired to turn the heel into the bar. Strike on the end of the heel projecting over the horn. Then reverse the shoe and proceed in the same manner with the other heel.

(b) When the quarters are of the correct length, heat the bar to a white heat and draw it out by working on the face of the anvil. This will lengthen the bar and at the same time reduce its thickness. After drawing out in this manner, the bar must be leveled with the upper surface unless the frog is so large that it will produce the desired pressure. The bar may also be drawn on the point of the horn, working on one half and then reversing; this method thickens the bar and should be used if the frog is very small.

MANUFACTURE OF COMPRESSED ACETYLENE GAS

Every user of acetylene gas knows that it is produced by the action of water on calcium carbide, but the preparation of carbide and the compression of its gas is still something of a mystery to the average man and there are details in this connection that are not generally known.

Lime and coke are first finely crushed and then thoroughly mixed. The mixture is then dumped into an electric furnace where the intense heat speedily converts the materials into a dark blue-grayish slag that is easily crushed—that is carbide.

Acetylene gas is not poisonous when taken into the lungs in small quantities but if it is allowed to mix with air in a confined space any flame brought near it is likely to result in a heavy explosion.

When water is brought into contact with carbide and all the gas has been obtained, there remains in the bottom of the generator a greyish-white sludge that is nothing but slacked lime. Hitherto the disposition of vast quantities of this sludge has been a matter of considerable

difficulty to the commercial manufacturers of the gas. Recently experiments have been undertaken looking toward the utilization of this material which has been wasted and satisfactory results are said to have been attained in using the sludge for wall plaster.

A pound of carbide will generate about $4\frac{1}{2}$ cubic feet of acetylene gas.

In the preparation of the compressed gas there are certain precautions that must be observed for when the gas is compressed to more than 30 pounds it is liable to explode simply from concussion. Therefore, to overcome this danger the gas is dissolved in acetone which is a component of wood alcohol. Acetone has the very remarkable property of absorbing, at normal temperature, about 25 times its own volume of gas for each increase in pressure of 15 pounds.

The volume of the acetone increases at the same time with its

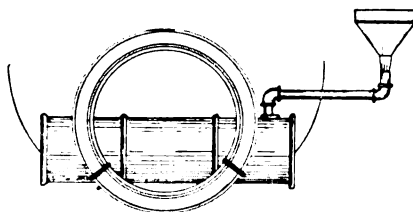

HANDY DEVICE MADE OF $1\frac{1}{2}$ INCH PIPE FOR REACHING OUT-OF-THE-WAY GAS TANKS

absorption of acetylene being approximately one and one-half times greater at 180 pounds than at atmospheric pressure, or about 15 pounds. At pressures varying from 150 to 180 pounds it is known as "dissolved" acetylene.

If a steel container were filled with this liquid at the pressure mentioned and placed on the market the pressure of the gas would gradually decrease as the volume of the gas was reduced and as the volume of the liquid became correspondingly reduced although no liquid had actually been taken from the container. Hence it would follow that an ever increasing air pocket would be left in the bottle into which the gas remaining would expand, forming a pocket of gas liable to explode by concussion.

This difficulty has been overcome by filling the gas container with a porous cement of either charcoal or asbestos, but usually the latter. This cement must be so arranged as to permit of no shrinkage.

Acetylene gas compressed in this manner has a freezing point of 49 degrees below zero. This feature is

a very valuable one as an acetylene generator must be kept above 32 degrees to prevent from freezing.

To guard against and prevent the explosion of acetylene tanks in case of fire, manufacturers are putting a fusible plug in the ends of the cylinders that melts at a certain temperature permitting the gas to escape and burn freely. Cases are known where the heat has been so intense that the brass gauges and fittings were melted but no explosion resulted.

From these reasons it can be very well concluded that compressed acetylene can be considered as being absolutely safe with none of the disadvantages or risks connected with the generator system.

SAFETY BREAK PINS

In the repair shops in country districts there is a good demand these times for safety pins for tractor plows. These pins are used in the tractor-plow hitch, so that when the plow strikes an obstruction which might do damage the pin breaks and releases it. These pins are made of hardwood and most plow concerns supply a few with every plow sold. The woodworker who has a lathe can profitably use a lot of his old hardwood stock by getting samples of the plow pins mostly used in his district, turning up spare pins in an odd hour. A steady demand for those pins is found wherever tractors are used.

STICKING VALVE CAPS

Valve caps have a way of sticking in place so as to defy all ordinary efforts to dislodge them. When this happens, it is a good plan to cut out a section of the rim with a cold chisel and then drill a series of three sixteenths-inch holes from this cut out section of the rim up to the threads. Enlarge this series of drill holes into a slot with the chisel and then give the rim a smart tap with a steel bar or other convenient piece of stock. This can be easily unscrewed.

FUEL LINE REPAIR

There are many convenient ways of making emergency repairs on the fuel line, wrapping with tire tape and varnishing being one of the best. When it is possible to make a more permanent repair, the pipe may be wrapped with fine copper wire, which should then be soldered over.

Queries-Answers-Notes



THIS department is the meeting place where you are free to ask for information, answer questions, discuss shop matters and business conditions and any other notes you feel would be of interest to a fellow mechanic. Make use of this Department as often as desired.

Needs it just the same—"I have had to quit general blacksmithing on account of my health and am now working as a machinist, making good at it and like it fine. Whether I work at general work any more or not I must have the Auto and Tractor Shop so as to keep posted with the times."

A. C. Wagner, Kansas.

Repairing Fords—"I have taken Ford car repairs as a side line to the blacksmith work and have been so busy that I haven't had time to think."

J. A. Cook, Mississippi.

Wouldn't Miss It—"I wouldn't miss my paper for anything. It's just the paper for my business or anybody else."

E. J. Reidelbach, Wisconsin.

A Mysterious Patriot—The picture shown elsewhere in this department was received a short time ago and signed "New Jersey Blacksmith". We don't know who he is any more than you do but everybody is entitled to a guess. He states that he is past the draft age but avers his allegiance and devotion to our country and its cause with the following oath:

"To my country and its brave defenders I pledge my life, my fortune and my sacred honor."

Kansas Association to Meet—The Blacksmiths', Horseshoers' and Wagonmakers' Association of Kansas will hold their 12th. annual convention at Hutchinson, Kansas, November 13 and 14. This convention will be of great interest to the trade throughout the state and every mechanic should make an effort to attend. A varied and interesting program has been prepared that will be of value and interest to all.

Some Kansas Observations—"I have been a reader of your journal for many years and received many valuable helps and much interesting information. The progress of time and methods of doing things would be hard to keep pace with were it not for the journal that comes to me every month brimful of new ideas and helps from all parts of the world.

"What a change has taken place in the last few years. I attended the recent National Tractor Show at Salina, Kansas. I have heard and read about such shows but did not realize it was such a big affair until I saw it. It would take entirely too long to describe all the details of the show. About one hundred or more tractors of all different sizes and makes were at this show and it was not the least bit of trouble to plow a section of land in two hours. The tractor sales at this show was the greatest ever, the Fordson taking the lead in the sales. About 500 Fordsons were sold in the three days of the demonstration, after which it was not possible to get one at any price.

"We have a lot of tractors in our local-

ity already in use and more will come in use next year and all this will mean a lot of repair work for the blacksmith and repairman. Out in this great state of ours there are very few who are not learning the motor repair business and with the additional work of all kinds coming in there is a great future for the blacksmith if he will but grab the opportunity.

"Some smiths are still mourning over the lost horseshoeing and buggy repairing but the only thing to do is to forget it, clean up your shop which will give them plenty of room for auto and tractor work, read the American Blacksmith, Auto &



OUR MYSTERIOUS PATRIOT, WHO IS HE?

Tractor Shop, which will give them information about such work; be business men, charge for your work and collect it.

"The blacksmith organizations are teachers in the same line. I have attended nearly every convention of our association and have always found it worth the time and expense. We get different ideas from all over the state. The brotherly feeling present at these gatherings between competitors is carried outside of the convention and they have gained confidence and mutual respect for each other and this good will is bad for price cutting.

"The only price system to follow is the "overhead" system and especially at this time when everything is sky-high so that if one is not careful he may pay out some money for the privilege of working, but here again comes the Journal. The man who reads it will benefit in many ways; better mechanically and better financially."

G. E. Johnson, Kansas.

TO ADJUST FORD STEERING GEAR—

A Ford touring car was brought to me to have play taken up in the steering gear. As I have just started in the automobile repair business I would appreciate your assistance.

J. H. Snell, Pennsylvania.

When the two small retaining keys on the top of the steering column wear only slightly loose there will be a relatively great amount of slack in the steering wheel. Keep them snug and firm. It may also result from depreciation of the teeth of the small planetary pinions and internal gear mounted under the steering wheel spider. These should be replaced with new ones when worn. The steering wheel is removed from the steering column and pulling off the spider hub from the shaft to which it is fastened. The interior of the steering gear may be easily inspected, after the steering wheel is removed, by loosening a set screw and unscrewing the brass cap covering the reduction gear case. The steering wheel can be removed from the steering post by driving it off the shaft with a block of wood and a hammer.

Glad To Do Favors Like This—"Please send me a price list and catalog of automobile accessories. I am a blacksmith and have a good shop operated by gasoline power and intend taking up automobile work.

I would like to have an air tank to be worked by my engine and would buy one that had been used."

J. M. Cardinal, Oregon.

South Africa Sure Has some Interesting Writers—I have been reading your paper regularly for the past 16 years and I must say that it has given me and many of my employees useful tips and knowledge on everyday work. I, as a smith, take perhaps more notice of the smithing notes, oxy-acetylene welding and especially the power hammer, of which more anon. Our painter also is greatly interested in your series of motor painting articles. I have been smithing for the past 35 years, the last 18 of which have been in this city, and am still as fond of the craft as ever and have a great respect for my Hay-Budden 3½ Cwt. anvil. It rings as true as a bell and is a credit to its U. S. makers.

We have four fires in constant use and they are all fitted with Hay-Buddens. We anticipate putting in several more heavy fires to cope with our heavy work of which we have an increasing trade. Our fires are all Champion Blowers and Forge Co., and are blown by a Champion electric blower to each forge and have given complete satisfaction. We have also placed a further order with the Champion Co., for their largest style forges and blowers, also one of their Hercules electrically driven power hammers, the largest they catalogue, No. 1, to handle our heavy work. We also anticipate a want for a further and heavier power hammer to handle drillers stuff such as the Keystone and Star drill stems as these run 4½ to 5 inch stuff and some of them are good, hard steel at that. I think your smiths must allow us some credit for being able to make a weld on these with 28 pound sledge hammers, using Kaffir boy strikers in relays. I always use four of them and am able to put in the scarf of a male and female heat in twice to the fire and anvil for which we give them every credit (but little money). A tot of F. C. (or Colonial Brandy) at knock off time ("Twould never do to let the mission-

ary societies hear of this. Ed.) goes a long way when a heavy job has been finished and laid down.

I would like some of your power hammer ink-slingers to give us a recommendation for the best hammer and size to install for handling this class of work. Also enclosed you will find a rough sketch of a broken drill jar. These have given us much trouble to repair as the steel used in some that we have run across is very hard to weld seeming to be of the cast steel variety. Any of our smithy friends who have had experiences of this class are invited to write through your medium.

You may be interested in knowing what class of work we handle so I will give you a few details; horseshoeing; cartbuilding, anything from a hand cart to a buck wagon, Cape carts, buggies, gigs, spiders or light four wheelers; oxy-acetylene welding; engineers smithing; wood bending; gate making, motor repairs of all sorts; coach and motor painting sign writing, etc., (We swear by Valentines colors).

We are the Orange Free State and Basutoland agents for the good old American Hupmobile motor car and are jobbers of all accessories and supplies to blacksmiths and wagonmakers generally, so you will note that we should be fairly busy one way or another.

Prices are sky-high for all materials here just now. Iron averages sixpence to ninepence per pound; half round 1/s per pound and spring steel 2/s per pound; Horseshoes 75 shillings per keg of 100 pounds (approximately \$15.75) and almost unobtainable at any price; horseshoe nails 2s/6d per pound. Work is brisker than I have ever known it to be in my 18 years of South African experience.

Thanking you for past favors and trusting that this letter will lead to a brisk correspondence with other brothers of the anvil although I know their fists do not take kindly to the pen.

E. S. Humphries.—Humphries & Lammas
Orange Free State

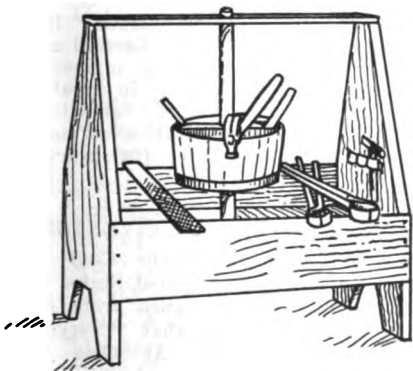

H. A. WHITE USES A CONVENIENT TOOL BOX IN HIS MINNESOTA SHOP. THE CIRCULAR BOX HOLDING THE DIFFERENT NAILS REVOLVES

Wants to Build a Planer—I will try and let you know that I certainly appreciate the magazine I have been getting from you for some time, it is surely a great help to me. I have been in the blacksmith business for nearly five years and have learned the trade by myself with the help of the paper.

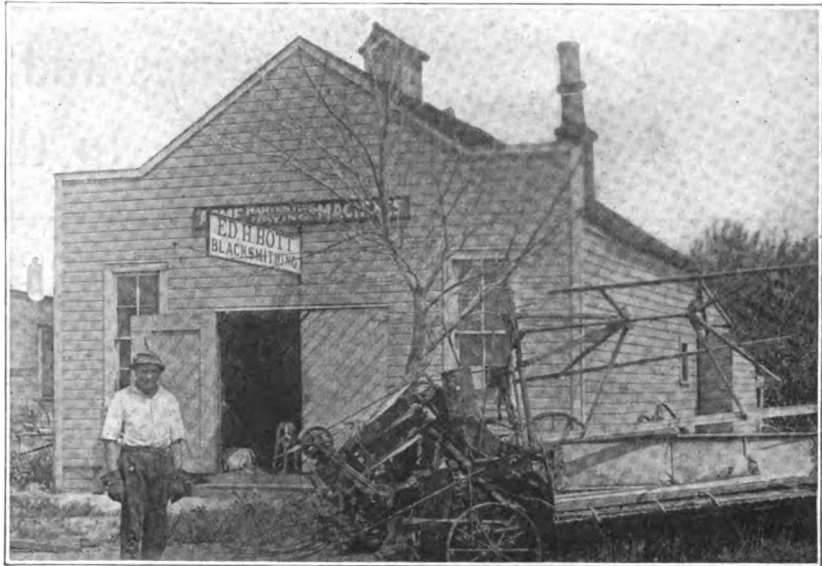

MINNESOTA PRODUCES AN UP TO DATE AND PROGRESSIVE LOT OF MECHANICS AND OUR FRIEND ED BOTT HERE IS ONE OF THE BEST

I borrowed three volumes from a friend and sure found interesting things and learned a great deal from them.

I would like to ask if anyone in the trade has tried to make an iron planer and what success they have had. I would like to make a light one if possible, for light work. If anyone has anything on this please answer through the journal.

V. B. Edwards, Idaho.

We Get a Bouquet—"Have enjoyed the paper very much and wish you success in the future. I am glad to note your progressiveness. L. A. Holcomb, Arkansas.

It's an Ill Wind, Etc.—In an error made by the persons sending in a subscription, Mr. W. D. Gallagher, of Michigan has been receiving the Auto & Tractor Shop. He also received an invitation to "rally" for another year when the subscription expired.

Mr. Gallagher is not a blacksmith but he says that there are many things of interest in the paper to those who do not belong to the trade and that he has always held the opinion that the man behind the anvil and the man behind the plow were men to be considered.

Change in Location Good for Him—In asking us to make a change in his address Mr. Clarence J. Loux, of Pennsylvania tells us that he has worked at his new location for several weeks and says that the change has more than paid him. He is in a prosperous farming district and says that he is up to his eyes in work.

Mr. Loux tells us that he has discovered that if a community is not what it should be it is best to look for another location and then clear out. There are lots of them open and a man is more than foolish to continue in a place where he sees that there is little or no opportunity for improvement.

"BOOKS RECEIVED"

I received my copies of Dyke's Encyclopaedia and Foden's Mechanical tables in good condition. I was very pleased to get them and will find them of great use. Had a glance through Dyke's book and it seems to cover all matters pertaining to the automobile. Have stacks of work at present.

H. F. Thompson, Western Australia.

Dressing Picks—"Can you give me a simple method of dressing picks?"

I. M. Jones, Pennsylvania.

Take a Piece of 3/4-inch square or 7/8-inch octagon steel, about 75 point carbon. Flatten down to an edge, spreading out point like a swallow's tail. With a hot chisel cut out the center in an A shape. In this piece cut two nicks, so as to raise two little spurs. Let steel get nearly cold before inserting in the pick and drive it well in. Don't split the pick more than is necessary. Jam the steel well down and the three-cornered spur will hold steel solid. Get a good soft heat and use some welding compound; weld and dress point.

Increased Business From \$500 to \$4,500—For four years this thriving manufacturing city of 3500 inhabitants held the distinction of being the only town in California with a population of over 500 without a garage. Car owners had been compelled to depend on Daly City and Colma, 3 miles away, or San Francisco for service. W. C. Wickmire saw and grasped an opportunity which had been passed up by many and erected the South City garage on a prominent corner about 3 months ago. His total capital then was less than \$500; last week he refused \$4,500 for his business.

Mixture Too Rich—I have a Rambler from which I do not seem to get the service I should. I cannot use a hot air tube and the engine backfires going down hill, but seems to do well on an ordinary pull. The throttle is set so that the motor just turns when starting. What causes the backfiring? Ignition seems O. K.; compression is good and no carbon, yet I only get about nine miles per gallon of gas. What do you suggest?

J. E. Hackney, Glen, Pennsylvania.

The Trouble is Probably too rich a mixture, as the engine backfires going down hill. The float probably sticks or leaks and this accounts for your poor gas consumption.

When a nation feels that it has more friends than it needs all it has to do is to start a war.



Accessories and Supplies of Interest to the Trade

AN ATTRACTIVE WINDOW DISPLAY

To assist their dealers in increasing their sales of Peerless Color Finishes, the Columbus Varnish Co., has arranged an attractive series of window displays and that they are attractive can well be judged from the picture shown below.

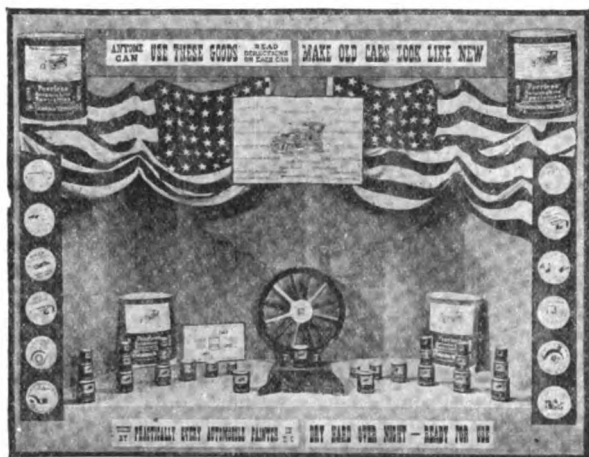

THE COLUMBUS VARNISH COMPANY'S ATTRACTIVE FALL WINDOW DISPLAY

The Columbus Varnish Company, of Columbus, Ohio, manufacture a complete line of automobile paints, and paint specialties for upholstery, tops and body refinishing and preservation.

The Columbus Varnish Company will be glad to receive your request for information, prices and other details that you may be interested in.

ADMIRAL WELDING MACHINES

Conservation is not a new word, but it has a new meaning for most of us. Especially is this true with reference to metals. Machinery of all kinds has advanced in cost very materially and it is difficult and many times impossible to secure repair parts.

The reclaiming of broken castings with the oxy-acetylene welding process has grown from a few scattering welding plants of a few years ago, until to-day in many parts of this country, every blacksmith and repair shop is equipped to handle this class of work. It is estimated that there are 3000 welding plants in the State of Kansas alone. Over 2000 of these are Admiral Welding Equipments. Strange as it may seem there is more welding for each of these plants than in communities where the plants are scattering.

Most of these plants are operated by blacksmiths, and very few of them have had any instruction or training except that gained from the instruction book, furnished with the apparatus, yet they are doing good work, making big profits and saving hundreds of thousands of dollars over the cost of buying new parts, to say nothing of the saving in time, and the increased production by keeping the machinery at work.

A few years ago a welding plant was a cumbersome complicated machine, de-

signed to generate both oxygen and acetylene. Numerous accidents occurred as the generating of oxygen from the chemicals is always hazardous even under the direction of an expert. The gases thus generated were impure and failure to do good work was common. Welding rods and fluxes had not been developed and there was a great deal of these supplies on the market of inferior quality.

Welding apparatus, at that time, was sold almost exclusively through specialty salesmen, and a demonstrator was sent by the manufacturer to install each plant and get the customer started off properly. The expense of selling in that way was enormous and on account of the small volume of business, even by the largest companies, made the overhead cost extremely high, and the cost of the welding plant was prohibitive for the average shop.

However, with the installation of branches in all of the principal cities where oxygen and acetylene can be secured in steel cylinders, so that it was not necessary for the customer to generate these gases, eliminating all danger of explosion, and making it possible to sell a thoroughly efficient and practical welding outfit at a price within reach of any shop, we placed the Admiral Welding Equipment on the market, selling it through jobbers, and it immediately sprang into favor as its advantages over the generating plants are manifold.

We give below a few of these advantages:

Portability; It can be moved to any part of the shop, taking up a very small space, or it can be loaded in any touring car and taken to the work in the field, over any kind of roads.

Economy; No gas is wasted as only the amount required to do the work is used. The time required to care for and operate the generating plants with the loss of

gases generated but not used is a very considerable item.

Price; Our low prices are due to a small profit on a large volume of business, with a low overhead and low selling expense. Every detail of the apparatus is of the very highest quality obtainable, and no expense is spared in the manufacture to secure the greatest efficiency.

The Admiral Welding Equipment has been developed under actual working conditions in our job shops where we handle every kind of work. The smallest job was putting an eye in an ordinary knitting needle; the largest was the main frame of a 550 h. p. engine weighing approximately 40,000 lbs. which was welded in place without removing any part from the engine. Both of these jobs were welded with the same welding torch, in fact we manufacture only one size, kind or style welding torch.

The Admiral Welding Machine Co., 1331 Walnut St., Kansas City, Mo., will be pleased to furnish you with prices, catalogues, etc., on request.



View of Witte Engine Works, Kansas City, Mo.—Largest, Exclusive Kerosene and Gasoline Engine Factory in the world selling direct to user. This factory was established in 1870 and has been continuously under the management of Ed. H. Witte, president and principal owner, since 1884. Since this picture was made, another large factory section has been completed covering approximately 10,000 feet of floor space. It will be used solely for the erection of portable engines and saw-rigs. Sawrigs are now in great demand on account of the big campaign of the U. S. Fuel Administration urging the general use of wood for fuel wherever practical.

OPPORTUNITIES FOR INVENTORS

Several years before the Civil War broke out one of the United States pension commissioners resigned from office giving as his reason that "everything had been invented." At that time there were no telephones, electric lights, automobiles, or thousands of the other things that now constitute everyday necessities of life.

Manufacturers and individuals are constantly on the lookout for some promising idea to develop.

If you have an inventive turn of mind and want to capitalize it write to Chandlee and Chandlee, 411 F Street, Washington, D. C., and ask for copies of their book "How to Obtain a Patent" and also a list of inventions that manufacturers have requested. These are both free and will be sent on request.

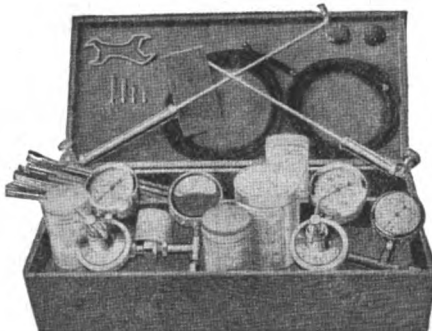

A COMPLETE WELDING OUTFIT,
READY TO TURN ON THE GAS
AND GO TO WORK FOR \$60

AMERICAN BLACKSMITH AUTO & TRACTOR SHOP

VOLUME 18

NOVEMBER, 1918

NUMBER 2

BUFFALO, N. Y., U. S. A.

Established 1901. Published Monthly at the Sidway Building, Buffalo, N. Y., by the

AMERICAN BLACKSMITH COMPANY

Incorporated under New York State Laws.

WILLIAM F. WENDT, *President.*

WALTER O. BERNHARDT, *Editor.*

SUBSCRIPTION PRICE:

For \$1.00 per year, payable in advance, The American Blacksmith, Auto & Tractor Shop will be sent, postage prepaid to any postoffice in the United States. To Canada, \$1.25; to other countries, 6 shillings. Reduced rates to clubs of five or more on application.

Remittances may be made by money order, express order or checks payable to the American Blacksmith Company. We will also accept uncanceled postage stamps or currency, but for safety these should be sent by registered mail.

Subscribers should notify us at once of non-receipt of paper or change of address. In latter case, give both old and new address.

Correspondence on all smithing subjects solicited. Always give name and address, which will be omitted in publishing, if desired. Address all communications to the

"AMERICAN BLACKSMITH COMPANY"
BUFFALO, N. Y.

"Copyright W. F. Wendt Publishing Company, 1918."

Cable Address: "Blacksmith, Buffalo"

OUR ANSWER AWAITED OVERSEAS—SEVEN ORGANIZATIONS COMBINED IN UNITED WAR WORK CAMPAIGN

Because there is strength in unity, seven organizations have joined together for a United War Work Campaign. The campaign, which extends from November 11 to 18, has a combined budget of \$170,500,000 as a goal. For a generous response to this appeal all that is required is a realization of what the various agencies are doing in our cantonments here and with the men overseas. The list of agencies who have unfurled a common banner for the campaign includes the Young Men's Christian Association, Young Women's Christian Association, National Catholic War Council (Knights of Columbus), War Camp Community Service, Jewish Welfare Board, American Library Association and Salvation Army.

Accordingly the layman in war work circles, long accustomed to think of each of the seven as a separate entity, must change his mental habit for the duration of the campaign and think of them as a definitely cooperative body. This should not be difficult of accomplishment since all have had the common purpose, that of surrounding our fighting men with wholesome home environment and thus keeping up morale, ever since the entrance of the United States into the war. Also it must be remembered that they are not private agencies. Every one of them is operating under an Executive order of President Wilson. The budget of each has been passed upon by the War Department and the work of each organization is governed by a War Work Council of nationally known men and women.

"IT'S AN ILL WIND, ETC."

The purging which the automobile industry is experiencing and will continue to experience for the duration of the war will prove to have been its salvation.

So notoriously has the maximum output been oversold, that any automobile, however lacking in merit, has sold with little or no effort. Such a market condition has really put a premium upon shoddy manufacturing.

DON'T GIVE MONEY TO AGENTS

The American Blacksmith, Auto & Tractor Shop DOES NOT employ subscription agents. Any person representing himself as such is an impostor and should be so dealt with. Notify us immediately if anyone claiming to represent this journal calls upon you.

CONTENTS—NOVEMBER, 1918

| | |
|---|----|
| How I Built My Own Power Hammer | 29 |
| Rainy Day Musings | 31 |
| Tips in Metal Working | 33 |
| Removing Ford Clutch Springs | 33 |
| Historical Developments of Acetylene Welding | 34 |
| Gasoline Tanks | 36 |
| Cheap Paint Remover | 37 |
| Radiator Plug | 37 |
| Lessening Headlight Glare | 37 |
| Keeping Windshields Clear | 37 |
| Legal Considerations in Sale of Used Automobiles | 38 |
| Repointing Tools | 39 |
| Tempering Rock Drills | 39 |
| Lubricating Valve Stems | 39 |
| Flux for Brass | 39 |
| Soldering Paste for Copper Wires.... | 39 |
| To Blacken Zinc..... | 39 |
| White Brazing Solder..... | 39 |
| Enamel Glaze for Iron..... | 39 |
| Repairing Storage Batteries..... | 40 |
| Chevrolet 400 Electric System..... | 42 |
| The Steel that Goes in Auto Springs | 45 |
| Annealing Methods | 47 |
| Shoeing Refractory Horses | 48 |
| Care and Repair of Storage Batteries | 49 |
| A Blacksmith that Wears a White Collar | 49 |



K of C Supply Trucks leaving Paris on their way to K of C huts behind the battle lines.



Colonel Barker and one of the Salvation Army trucks which take supplies to canteens over shell swept roads.



A Salvation Army Brigadier Greeting a unit of the A.E.F. resting on its way to the front in France.



One of the Y.M.C.A. auto trucks which supplies the canteens with the British Army in Palestine.



The motor car circulating library of the American Library Assn. which takes books from camp to camp.

How I Built My Own Power Hammer

Otto A. Wagner.

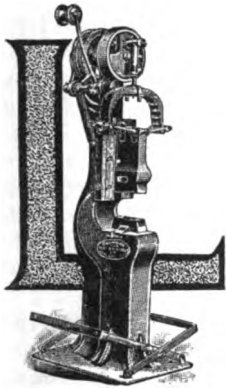

LAST winter. I had a lot of spare time on my hands and having long felt the need of a power hammer that would enable me to handle more work and handle it quicker, I decided that I could utilize this time and build a

power hammer of my own, and, for the benefit of others, I have endeavored in the following article, to set forth as clearly as possible how this was done, both in pictures and text.

To begin with I formulated certain theories that I thought ought to be embodied in a good power hammer and they are; That the anvil of a power hammer should be separate from the frame to relieve the bearings, etc., of the severe jar that they would otherwise receive. My observations taught me that the anvil of the hammer should have some springy substance interposed between it and the concrete base for the good of both the base and the machine. I further concluded that a small power hammer should be built self-contained. Another thing that I decided on was that the ram must be balanced in order to give lasting satisfaction and not continually be breaking the guides and other parts. These ideas of my own I endeavored to incorporate in my first try.

It further stands to reason that after one has built his first machine he would learn some things so that if he were to build another he would be almost certain to make some slight changes.

If I were to build another, I would change the dimensions in some particulars. In this I am going to give my readers the benefit of my conclusions and use such dimensions as I would use in the construction of another machine.

To begin with, I selected oak timber as being the best material for the base. I made this by bolting together with 3-8 inch rods four pieces of 4x6 and one of 2x6, forty-two inches long, so as to form a wooden base 18x6x42 inches.

The bolt heads that fasten the frame and anvil to this base should be countersunk on the under side

These were sunk across the grain of the timbers. Using "T" head bolts and placing them across the grain, they will not turn and are easily sunk, besides they will not cut into the wood, as I made the "T" heads about two inches long. The bolts for the frame, six in number are 7 inches long and the anvil bolts are 8 inches in length.

Before assembling this base I put in a 5-8x6 inch "T" head bolt 3 inches from the rear end of each of the two outside pieces on which to hinge the foot treadle.

For the anvil I made a pattern of soft pine wood and had a casting made of it at a nearby foundry.

The flange at the bottom is 16 inches in diameter and 11-2 inches thick. The body is 12 inches in diameter just above the flange and 8 inches in diameter near the top and is 24 inches high. The dovetail slot across the top is 2 inches wide at the opening 11-8 deep. There are six holes in the anvil flange for the bolts. These holes were drilled with an 11-16 drill.

The anvil pattern was made in one piece and was turned on my lathe. The slot at the top was made with an outward draft for convenience in moulding. I made sufficient allowance for material to be chipped out of the casting with a chisel. A planer would have been better and made a little neater job but I didn't have it. In order that the best iron would be where the most strength was needed, I had the moulder bed the pattern in top side down.

The material for the frame should be 31-2x3-8 inch angle iron for the feet, uprights and crosspieces and 4x3-4 inch flat stock for the guide supports and 2x3-4 inch flat for the braces. The riveting should be done with 5-8 inch boiler rivets of the proper length

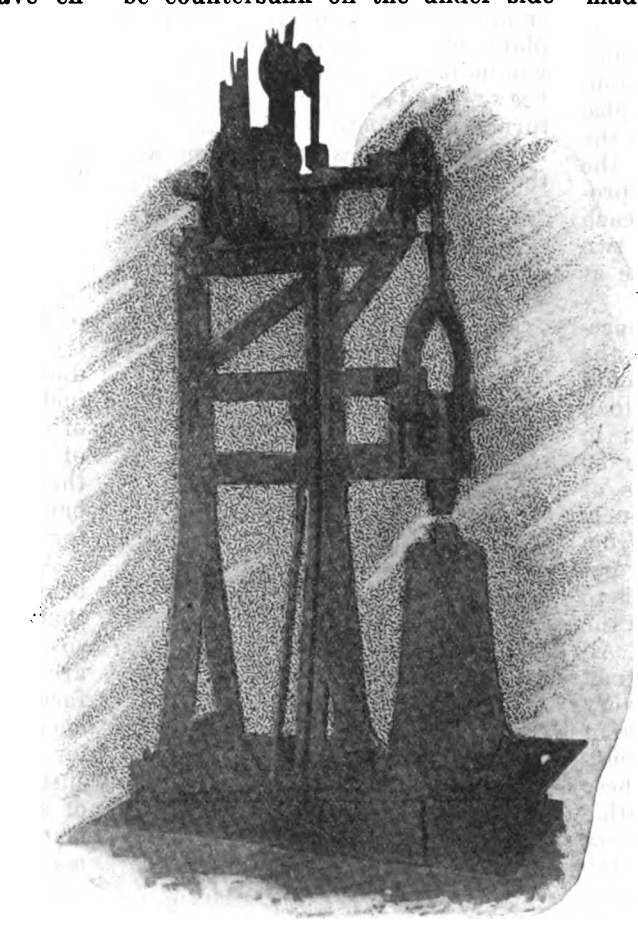

MR. WAGNER'S POWER HAMMER COMPLETED AND READY FOR WORK

of the base so that they will not interfere with the fitting of the base to the concrete. I made these bolts with "T" heads of 5-8 stock.

for each place, driven hot and properly set at top and bottom.

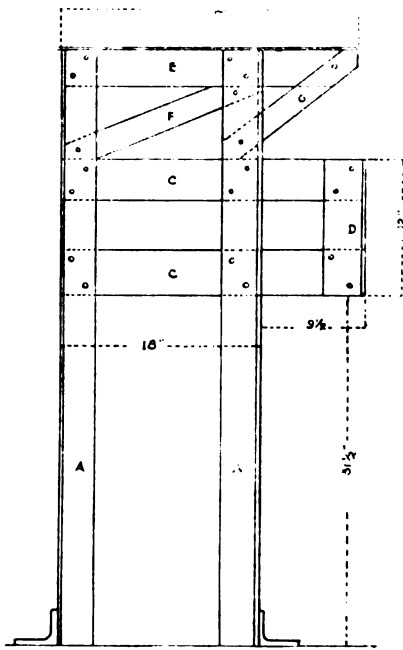

FIG. 1

The feet of the frame are 18 inch lengths of angle iron to which the uprights are riveted with two rivets at each joint. Holes are also drilled in these for the bolts fastening the frame to the base and also a hole near the ends of each for the anchor bolts for fastening the machine to the foundation. I provided six bolts; two through each of these feet and two in the two front corners of the wood base at the anvil end.

Fig. 1 and Fig. 2 show respectively side and end views of the frame. The four uprights should be made of 3 1-2x3-8 angle stock and should be bent as shown in Fig. 2. The frame should be 56 inches high, less the thickness of the top angles which is 3-8 inch. The bend should be 31 inches from the top end. The best way to get the uprights the proper length is to lay out the spread and measure the angle, bend it to the 31 inches. Allow material to cut to the exact length after bending as it is very difficult to tell just how a piece of angle iron is going to act in bending. I was particular to get these uprights exactly the same length.

We will next note the top pieces E. in Fig. 1. They are cut from the same material as the uprights and are 27 inches long and should be riveted flat together as shown in Figure 2, care being taken to have the sides come level with each other so as to form a level surface to bolt the bearing boxes down on.

The guide supports, C in Fig 1, should be made of 4x3-4 flat stock

27 1-2 inches long. They project out from the frame 9 1-2 inches and the two pieces D riveted on them are pieces of the same size angle as the uprights and are 12 inches long. Care must be taken to get them to form a flat face in line with the uprights because they serve as a fastening place for the guide bars which guide the ram in its vertical travel. The lower guide support C, should be 31 1-2 inches from the base. The braces F and G are made of 3-4x2 flat and the brace G should have a forked end to be riveted astride the top pieces E. The feet are of the same angle as the uprights, they are shown at B in Fig. 2. Fig. 2 shows how the top pieces E and the guide supports C are riveted between the uprights A. These joints are all riveted with 5-8 inch boiler rivets. Use an 11-16 drill for these holes and of course, drive the rivets good and hot with the proper sets for both top and bottom.

THE CRANK SHAFT — The crankshaft is 1 1-2 inches in diameter and 30 inches long. The crank plate was secured from an old windmill on which I shrunk a heavy band to reinforce it and turned up smooth on the lathe. It is about 9 inches in diameter and the center boss is 1 3-4 inches deep.

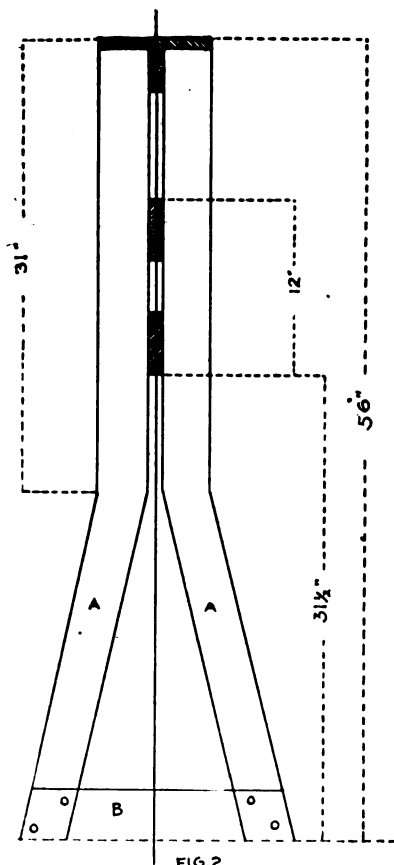

FIG. 2

The stroke should be about four

inches, that is the crank pin should be set eccentrically about two inches off center. I shrunk this

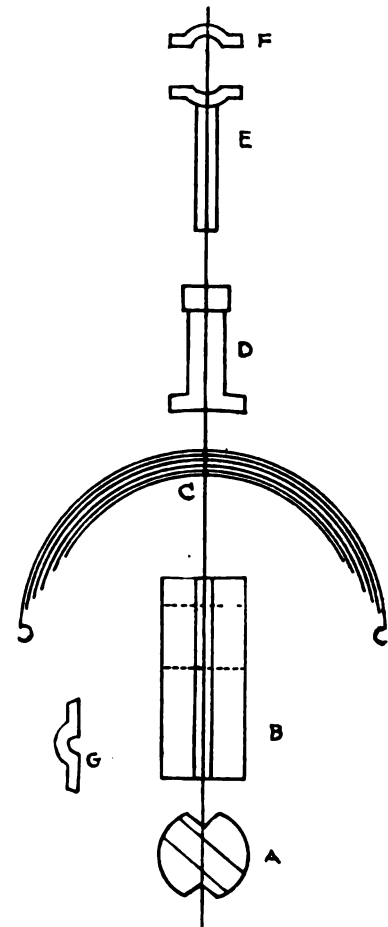

FIG. 3

plate on the shaft. The main pulley is an ordinary pulley with a diameter of 11 1-2 inches and a 6 inch face. On the two edges of the face I shrunk two bands of 3-4 inch square stock and then turned them up true. These bands serve as flanges and surfaces for the brake blocks to bear upon.

As can be seen in the picture, the bearing boxes are special castings, that is, they have legs cast to them so as to set them up a bit. They are 7 inches from the bottom surface to the center of the shaft and once did duty on an Aultman-Taylor steam traction engine. They just fitted the bill and instead of such luck I would have had to made patterns and had castings made. I have them bolted to the top pieces of the frame with two 3-4 inch bolts to each bearing.

The crank pin was turned out on my lathe and has a 1 7-8 inch bearing, the center of the bearing surface being 17-16 inches from the face of the crank plate.

RAM—Next came the ram, shown in Fig. 3. Parts A and B

I made from a piece of 4 1/2 inch shafting 11 inches long and weighing about 50 pounds. Here is where you get your hard work unless you have a planer or shaper. I used hammer and chisels, files and scrapers to chip out and finish the two "V" shaped ways that are diametrically opposite each other and which fit the "V" shaped guide bars. These ways are cut deep enough to make a wearing surface on each side of the center of 7-8 inch wide. Finishing these grooves with file and scraper takes patience as well as considerable time. The dovetail slot in the end of the ram for the die I also cut out by the same process. It is 1 1/8 inches deep and 1 1/2 inches wide at the opening and 1 3/4 inches at the bottom.

There must be two holes drilled through the ram crosswise and at right angles to the line that touches the centers of the "V" ways. The first hole is 1 1/2 inches from the top and the second is 3 1/4 inches below the first, on centers. I drilled them with an 11-16 drill and use a 5-8 inch rough bolt in them. These holes should be drilled straight through the ram and parallel with each other. I located and centered them on both sides of the ram and then drilled them between lathe centers, that is, I chucked the drill in the lathe and then put the work between the point of the drill and the tailstock center and drilled the holes half way from each side, feeding with the tailstock screw. Next I drilled two 1-2 inch holes endwise into the top end of the ram, and one on that line that connects the "V" ways. A short distance from the bottom. I drilled them about 1 1/4 inches deep and connected them to the "V's" with a 7-32 inch hole. These serve as oil holes for the guides.

At G in Fig. 3 is shown one of the ears that are bolted to the sides of the ram, one on each side. To make these I took 1 1/2 square stock and fullered on each side of the center and drew the ends out as shown in the sketch. I then chucked them in the lathe and drilled an 11-16 hole through them in the center part and then sawed it open and dressed it out so as to appear as shown. Then through the flat ends I drilled 11-16 holes to match those in the ram. These ears serve as bearings for the spring links and should have oil holes drilled.

For the spring links I used 5-8

round rods. On one side I made a solid link 8 inches long inside and 1 3/4 inches wide inside, with square bends at the corners having the end sections straight and round so as to form bearings for the ends of the spring and the ear on the ram. On the other side I used an adjustable link made with a U bolt and a yoke. Each side of the U bolt is 11 inches long and 1 3/4 inches between the square bends, leaving the end part to serve as a bearing in the ear of the ram on the other side. The outer ends are threaded up about three inches for a 5-8 inch nut. The yoke is a block of steel 1 1/4 x 1 1/2 x 1 3/4 inches. The center portion of this is turned down to 3/4 inch in diameter for a bearing which should be about 1 5/8 inches long. The bosses left at each end should have an 11-16 hole drilled through them in the direction that the block measures 1 1/2 inches. The bearing should be turned so it will come to one edge of the piece. This leaves material on one side of the bosses so that the adjusting nuts will not interfere with the hook on the end of the spring.

(Concluded in December Number.)

RAINY DAY MUSINGS

The other day it was raining; now this is no joke. It had rained for about a week and it was just the kind of a day that the garage man likes to see, as someone is sure to be in trouble about ten miles out on some back road.

We were gathered around the stove trying to keep the chill from getting too deep under our B. V. D's when the door opened and in came a man with a brigadier general shape who announced that he had a car down at the hotel that had suddenly and quite unexpectedly died on his hands. The starter would not start and the lights would not light and neither could he start it with the crank and he was afraid to build a fire under the engine or twist its tail. He admitted that he didn't know a thing about the trouble but he was quite sure that a fuse had "gone where the woodbine twineth and the whangdoodle mourneth for its mate", as the poet says.

The boss said he would go down in a few minutes, but just then in came a tire salesman and as he couldn't shake this bird, he came out in the shop and picked me for the goat.

I gathered up a few tools and an

umbrella for it was still raining as though it had a contract to fill with penalties provided for non performance. I was glad I didn't have to make a trip to the country too. Arriving at the scene of trouble the owner climbed into the car and showed me how it worked or rather, how it didn't. It didn't do much, that was sure. Pressing the starter button down didn't bring any more result than a Bryan campaign. And when the lighting switch was turned on the lights might come on or they might not, just as though they belonged to the union and knew it, or they might wait a few minutes and then light up—just like that, and as bright as any lights.

This car was equipped with a Remy starting and lighting system. This is a two unit system, with the starting motor in front of the transmission and the generator on the right hand side of the engine. On this car if the clutch pedal is locked out the starter will revolve the clutch but not the engine. The starting switch is under the front boards and as the pedal is pushed down the electrical contact is made and a brake is also applied to the loose chain sprocket and this causes a "dog" to engage in some notches and this in turn causes the engine shaft to turn.

As I have already mentioned,



THE DOOR OPENED AND IN CAME A MAN WITH A BRIGADIER GENERAL SHAPE

pressing the starting pedal down had nothing to do with starting the engine, so I took a pair of pliers and bridged across the terminals where the main wires

came from the storage battery. They were as dead, yea dead, and doubly dead again, as two bolts in the muffler. The owner observed that I didn't need to look any farther as a fuse was surely enjoying its afternoon nap. I told him that there were a few more places that would stand looking into that we would try first. I lifted up the boards over the battery and placed a pair of pliers across the terminals—nothing doing. The terminals, like the stage villian, when he slinks up-stage and hisses “cur-r-ses”—black and dirty. Anyhow the battery was as dead as Rameses but I scraped a bright spot on the terminals with my knife and when I touched across with the pliers there was something doing right off and the sparks flew in fine shape. The owner could not understand the sudden resurrection from the dead of his battery but I explained to him that I did not have a good contact the first time on account of the black deposit that I had scraped off with my knife. Even then he held to his opinion about the fuse having gone to the great beyond.

I took the battery cables from the battery which were the kind that taper and are pulled into place with a bolt. These ends were covered with a scale that was evidently

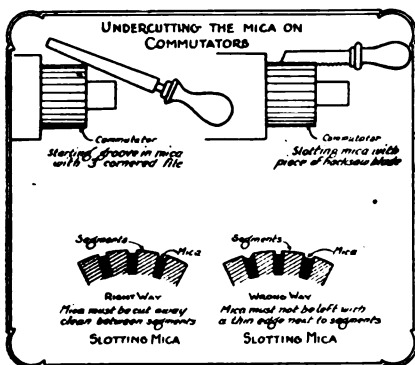

A RIGHT AND WRONG WAY FOR EVERYTHING

a poor conductor of electricity. I cleaned off both the wires as tenderly as a mother tending her first-born and tenderly returned them to their places. Then the starter button was pressed down and the starter worked as slick as a gold brick man with a good prospect. Naturally the owner was much impressed and admitted that he had learned something else that he didn't know before.

Another case of a similar character came in the other day and the boss tried the same thing but it didn't work. He turned it over

Double Reduction Gear Drive for Heavy Duty Trucks

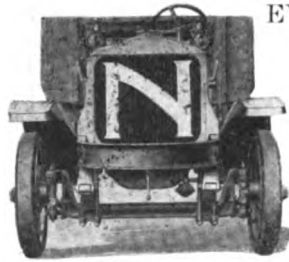

EW models of three and five ton White trucks, having among other improvements, a double reduction gear drive, have been announced.

In addition to a new drive system in its heavy duty trucks a unit power plant and, cast radiator of

to me, which was kind of him. The covers were removed from over the brushes and it was discovered that the brushes had worn down too short and that the commutator was very rough. The mica that separates the metal segments of the commutator was higher than the metal. I took the starting motor out and with a piece of an old hack saw blade, ground thin on an emery wheel, I sawed the mica down so that it was below the surface of the commutator. Then the armature was placed in the lathe and the commutator was turned down smooth. This operation should be done with a very sharp tool so that the metal will not be wiped across the gaps in the commutator. After turning it is a good plan to clean out the slots that have been made with the hack saw blade. Do not oil the commutator as it is not needed. After putting in new brushes, of which there were four, the starter was placed back in position, and connected and worked just as though it had come from the factory.

Occasionally a car will come in that fails to generate or start. If the battery is tested and shows a good charge in it we loosen all connections and clean the surfaces that have come together and nine times out of ten when this is done the trouble will disappear as quickly as grub placed in front of a German prisoner. It is also well to look at the ammeter to see that the hand is not sticking. We always make it a point to look at all the different electrical parts and usually find trouble with some of them.

the vertical tube type has been adopted.

The new rear axle design, which does away with side driving chains, is of special interest because, in addition to showing the solution of an important engineering problem, the design retains the advantage of chain drive and adds advantages of its own which produce greater efficiency. This is the only result that justifies changes in design.

As long as three years ago

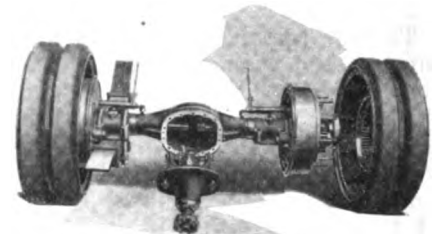

DOUBLE REDUCTION AXLE DISASSEMBLED

public announcement was made that White heavy duty trucks would continue to be chain driven until a better form of final drive was developed. At that time tests had proven no other form of drive as efficient under all circumstances as the chain drive.

The chain and sprocket afforded in a heavy duty truck a double reduction system—one reduction in a jack-shaft and a second reduction in the chain and sprocket wheels, thus giving a large range of gear ratios and, consequently, a greater flexibility than can be had in any single reduction shaft drive unless the gear housing is made very large and the rear axle, in consequence, heavy and unwieldy. Chain drive also has this advantage; power is applied to the rear wheels on a

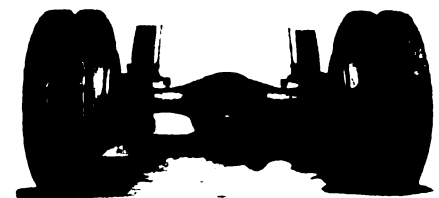

ASSEMBLED REAR AXLE

sprocket attached to them; power is thus applied nearer to the wheel rim and by a rolling contact between the chain and sprocket.

The new double reduction gear drive accomplishes the same result. There is a first reduction through the bevel gear and drive pinion in the center of the rear axle, from which the power is carried by a live axle of the floating type through the center of the housing to a gear at the wheel end of the live axle. This gear, in turn, meshes with a second gear (carried on the housing of the live axle, but inside the hub case of the rear wheel), and this second gear, in turn, meshes with a ring gear attached to the wheel inside of the hub case.

In this way of applying power to the wheel, a second reduction occurs between these gears in the hub case very similar to the reduction which takes place between the sprocket of a chain drive. The power is applied at about the same distance from the rim as it is in the case of the chain drive, thereby retaining that advantage. This use of gears makes a rolling contact throughout, without any elements to produce friction.

The adoption of the floating type of rear axle and the train of gears in the hub case of the wheel, enables the whole mechanism to be entirely encased and run in oil. The result is a comparatively frictionless running axle that cannot be cramped or get out of line, and has all of the operating advantages of chain drive with the added advantage in point of maintenance of being enclosed in a dust-proof case and in running in oil.

Chain drive had a further advantage over other types of rear axles in the fact that its unsprung weight was considerably less. The new double reduction rear axle has the same advantage in that the unsprung weight of the truck has not been increased but, in fact, decreased a little. The result will be at once apparent in the life of tires.

As in chain drive, the whole design is extremely simple. All parts are readily accessible. The live axles may be withdrawn without disturbing the wheels and the wheels themselves can be readily removed if desired. The bevel drive and differential gears are carried in ball bearings on a detachable axle plate and may be removed as a unit. Gear ratios can be quickly changed if necessary. The moving parts are simple and rugged, and in their dust-proof case running in oil, they are proof against rough usage. The axle housing is so compact that it affords practically the road clearance of a straight axle.

Tips in Metal Working

FRED HORNER

In the "English Mechanic"

WHEN BOLTS or screws have to be sawn off and repointed or ended, it is a good dodge to leave a nut on, some way up the threads, to be used finally to run off and force away the burr, which otherwise causes difficulty in starting a nut on the trimmed end.

If a centre-pop intended for striking important circles or distances from, becomes accidentally struck too deeply or out of place, a good way of getting over the difficulty is to fill the impression up with solder or white-metal and utilize the surface of this for a fresh pop.

In some kinds of repetition facing it is necessary to use a disc as a packing medium to bring the work out sufficiently to enable a tool to operate across the face. When a quantity of such work has to be dealt with, time can be saved by fix-

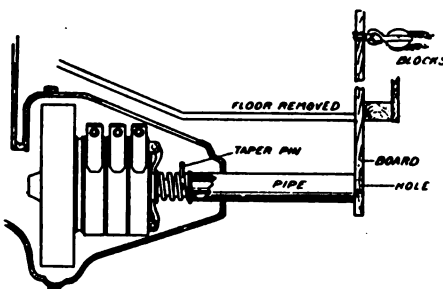

REMOVING FORD CLUTCH SPRINGS

ing the packing disc; this may be done by attaching a piece of rod by a thread to a hole in the disc and making the rod long enough to pass through the lathe spindle and receive a nut and washer.

Thin parting tools, whether used in lathe, planer, or shaper, sometimes give difficulty by tipping over when the clamps are tightened down on them. This does not matter much for shallow cuts, but in deep parting or grooving a very slight degree of tilting complicates the question of side clearance, and grinding on too much of this weakens the tool, besides taking time. A little safeguard is to grind a groove on the sole of the tool, so that in effect it is concave and will stand firmly, even on a rest or holder that may be not perfectly flat or smooth.

To hold screws or bolts against an emery-wheel for rounding or pointing the ends, it is convenient to thread a nut on a few turns up and hold the nut in the fingers while revolving the bolt against the grind-wheel. The smoothness of rota-

tion helps in obtaining a regular shape of end.

A saw-cut that has been started badly through the blade running to one side may not matter if the object is only to sever the piece. But if the cut is required to be straight, as for splitting a boss or dividing duplicate parts accurately after forming them from a single piece of metal, correction may be made, by employing a thicker blade, which, if the hack-saw frame is held firmly, may be fed through in a straight line, the stiffness preventing any coercion from the original saw-cut.

Nuts that have been case-hardened are most easily cleaned outside by running an old tap through. If such is not available, a substitute in the form of a mild steel tap, thoroughly well case-hardened, will do instead.

A fruitful source of cracking in the hardening of high-speed steel tools is through being impatient of waiting for the air-blast to cool the tool right out, and hastening the process by dipping the still warm tool in water or oil. Tools thus treated are likely to crack longitudinally.

The tops of letter or figure stamps should be kept small in area if uniform impressions are to be struck. When the tops spread, and acquire a comparatively large surface, it is difficult to strike a definite, even blow which will not drive to one side.

When cutting deep grooves in the lathe, difficulty is sometimes experienced through the tool and the slide-rest chattering, on account of the magnitude of the cut, especially if the grooves have tapered sides like worm teeth. The trouble can often be eliminated by turning the tool upside down and running the lathe backwards, so putting the slide-rest parts into tension, which is equivalent to a state of tightness, the difference between the compressive and the tensile stress having the peculiar result of arresting the chatter.

To file the end of a piece of tubing across squarely with the minimum of trouble, some form of guide may be utilized. If the pipe is threaded outside it can be run into the dies, leaving a trifle above, so that when the file is swept across a few times the state of the end will be apparent by reference to the face of the die. To prevent damage to the file a thin-faced washer might be slipped over the pipe end so as to prevent the hardened die from coming into contact with the file teeth. In the case of thin tubing, not screwed, a man-

drel having one end trued across is slipped inside and the two gripped in the vice, after which the pipe end is filed until it stands at an equal height all around in relation to the mandrel end. Of course, if the lathe is available, the quickest method is to trim the ends off in it, but circumstances may tie a lathe up for a considerable period, and so render the adoption of one or other of the above-mentioned dodges necessary.

A delicate test to reveal suspected movement of slides or other parts of the lathe is to run paraffin in between the joints and watch what happens when pressure is put on by a cut or other occurrence. If the joint faces separate ever so slightly this fact will be revealed by the sucking in of the oil and its expulsion subsequently. By catching the light on the surface of the oil correctly the faintest movement is easily seen.

When setting graduation lines to coincide, such as on a Starrett protractor head, the greatest amount of accuracy can be obtained, not by looking at the face of the instrument, but by casting the eye end on along the lines. A setting which appears to be quite "fair", viewed frontwise, may show error when one looks at the lines with the instrument raised to the eye-level and tipped horizontally. The reason of this will be obvious on considering how the workman looks for errors in the straightness of a bar or plate, by raising one end to his eye and squinting down the length.

A simple little dodge to enable the effects of adjustment to be observed, when the relative position of certain parts is going to be altered by pressure or blows, is to whiten the adjacent surfaces with whiting or chalk, and scribe a short fine line across from one face to the other. Then any displacement one way or the other will be seen, and if necessary the parts may be brought back to the original setting for a fresh trial. Should it happen that the faces do not lend themselves to scribing a line on, location may be observed by putting a couple of fine centre-pops and testing their pitch with dividers, or a bit of rod bent round at the ends to form fixed trammel points.

Although the sultan of Turkey joined the ranks of automobilists in 1901, he did not dare to trust his person to his machine, but seemed to find sufficient pleasure in looking on while two officers maneuvered it in front of his window.

Historical Developing of Acetylene Welding



XY-ACETYLENE welding in its present application may be considered to be a modern development.

In 1895 Le Chatelier read a paper before the Academie des Sciences of Paris in which

he stated that "Acetylene burned with an equal volume of oxygen gives a temperature which is 1,000° C. (1,800° F.) higher than the oxy-hydrogen flame. The products of the combustion are carbon monoxide and hydrogen which are reducing agents." He likewise stated that "This double property makes the use of acetylene in blowpipes of very great value for the production of high temperatures in the laboratory." His statement was specially noteworthy in that he set the ratio of gases at equal volumes and not at the theoretical proportion of 2.1-2 volumes of oxygen to 1 of acetylene.

To Edmond Fouche, of Paris, an engineer of the "Compagnie Francaise de l'Acetylene Dissous." belongs the credit of having devised the first really practical and safe torch. He began experimenting in 1901 and about two years later put out the first torches used commercially. He was in communication with Mr. Bournonville, of New York, and sent in 1904 two torches with one of which Mr. Bournonville repaired a broken machine which was still in operation four years later.

The process had its inception in the United States about the year 1905. While the process was handicapped at its early stages by imperfect knowledge and as yet undeveloped technique, the chief obstacle to its development was found in the inadequacy and unsatisfactory quality of the oxygen supply in the market. Upon the introduction of the liquid air and electrolytic processes of dissociating oxygen from the air this difficulty disappeared.

In 1906, Linde, the promoter of liquid air, came to the United States and after lengthy negotia-

tions constructed an extensive plant in Buffalo for the production of oxygen. At about the same time F. W. Clifford began the manufacture of oxygen by the electrolytic process at Suspension Bridge, New York. From that time on the number of oxygen plants has been steadily on the increase and plants already running have carried on improvements and increased their capacity. The greater supply of oxygen has been a factor in the growth of oxy-acetylene welding, and the increasing demands of the growing process have in turn been a stimulus to development of the oxygen industry, resulting in a greater supply on the market at decreased cost.

When conditions extant in this country some years ago are considered, it is surprising that the oxy-acetylene welding process should have developed as rapidly as it has. In general little thought was given to it, and it was erroneously looked upon as a very simple matter both as to the handling of the apparatus and the skill required of the welder. It took numerous unpleasant and unsuccessful episodes to force the realization that not only scientifically-designed and well constructed apparatus was essential, but that the welder should be conscientious, well trained, should possess a good working knowledge of the metals coming within his scope, and have in addition no mean amount of mechanical skill.

Welders in this country have been practically left to work out their own salvation. Instruction conducted along lines similar to that given in other trades has been sadly neglected. In fact, until in recent years most of the instruction given has been by makers of apparatus, who when making a new installation, and realizing that an incompetent welder might jeopardize the process, were principally interested in the business end of the transaction. Besides, this introductory instruction, brief and rudimentary as it was, lay in the hands of a practical welder, often a rather unsatisfactory type of teacher. As a result it was not rare to have a welder undertake a job relying

mostly on his nerve or good luck, with the result that when put to a test the weld often met with failure, discrediting the process.

Another stumbling block has been the lack of cooperation between the various welding interests in the country, and the nonexistence of a centralized organization which might act as a clearing house for gathering and disseminating valuable data, conducting experiments, and offering suggestions and advice.

At first operations were limited to the simplest repair work on iron or steel. As apparatus has been improved, however, and as the deficiency of the welder has increased, the process has widened its cope of usefulness from year to year. New uses have been found for it, some epoch making, and the range of metals coming within its compass has steadily increased. While it has its limitations, the process has proven itself a factor of efficiency and economy in many fields of industry, and is coming more and more into use as a valuable factor in many lines of manufacture.

Cutting — In addition to weld in the oxy-acetylene flame is adapted to cutting metals with accuracy and rapidity. Steel or wrought iron can be cut into shape at a speed varying from 4 to 20 inches or more per minute, depending on thickness, effecting a saving in both time, labor, and cost as compared with other methods. The process is a chemical one. Steel heated to a certain temperature will actively combine with oxygen. This is demonstrated by the familiar experiment of burning steel wire by dipping it, when red hot, into a jar of oxygen. The procedure consists in heating the object to be cut until it assumes a cherry-red color and then directing a strong jet of oxygen along the path of the desired cut, causing the metal to oxidize rapidly. The oxide or slag thus formed, which has a lower fusing point than that of the metal itself, runs off or is blown off, continually exposing fresh surfaces of the metal, which it preheats, to the oxygen and leaving behind a clean cut resembling the appearance of a cut made with a saw. It is important to note, however, that this behavior of the slag is confined only to the oxides

of wrought iron and steel (cast iron can not be cut owing to its oxide having a higher fusing point than the metal proper), and therefore those are the only metals lending themselves to the cutting process.

As the role of acetylene in cutting is purely that of a heating agent, other gases may be used in its stead. One of these is hydrogen, which is successfully used, and in heavier work is in some respects better than acetylene.

The welding torch is not practicable for cutting purposes, and a specially constructed, cutting torch is made use of, which differs from the former in that it is equipped with an additional outlet for supplying the oxygen needed for oxidation.



Automatic Welding and Cutting Machines.—Automatic welding and cutting machines have been devised and are in successful operation which replace the skill of the welder on jobs calling for the continuous or repeated performance of a single operation. They have the advantage of manipulating the torch in an absolutely steady manner.

The conception of welding machines dates back to about the time the welding torch came into use. Attention was first directed to the possibility of their use by some manufacturers, who, having to weld a series of identical objects, devised mechanical means for doing the work.

While the Europeans have been pioneers in this field and were the first to make pipe by this process, practically all of the machines in this country are of American design and construction.

There are at present various welding and cutting machines run by electricity at variable speeds which are used to turn out pipe at the rate of about a yard a minute; to weld barrels, transformer cases, radiator sections, etc.; to cut holes in rails; to cut out circular shapes; to cut intricate forms out of sheet steel, one or more at one operation and on any desired scale; and a variety of other work which on account of its uniform character does not call for the exercise of ingenuity or resourcefulness.

In cutting the automatic machine has the advantage over the welder, through its absolute steadiness in manipulation, in that it executes a clean, smooth cut along the lines laid down in the design.

A recent device is a cutting machine designed to be attached by means of magnets to steel surfaces, such as ship bulkheads. The cutting is done after the plates have been put in place, instead of the old way of cutting and then installing them.

OVERLAND GETS MOLINE PLOW CO.

The Willys-Overland Co. has obtained control of the Moline Plow Co., Moline, Ill., which manufactures the Moline-Universal tractor and an extensive line of other farm implements. The acquisition of this company places the Overland company in a position where it will be able to supply its dealers not only with passenger cars and trucks, but with the tractors and farm implements as well, while it is fairly well known that the Overland interests also are heavily interested in the Curtis company, thus making the automotive field complete insofar as Overland is concerned.

RADIATOR THERMOSTATS

Some of the higher priced cars have thermostats in the cooling system. These are usually located in the water outlet pipe of the engine and holds a valve closed at all temperatures below 150 degrees. This enables the engine to warm up quickly but it also assists the freezing of the water in the radiator in cold weather. It is therefore absolutely necessary to use an anti-freeze solution of some sort in the radiator when the temperature is below 32 degrees, or freezing.

THE GASOLINE TANK AND ITS ADJUSTMENT

If there is one part of the car more than another that gives the owner little or no occasion for worry, it is the gasoline tank. In fact about the only thought accorded this part is its capacity in relation to the price of fuel. The tank needs little attention, it is usually good for the life of the car, but once or twice a season there are minor adjustments of this part that ought to be made. The tank as a whole should be inspected, the fuel line connections tightened and the supports drawn up, two or three times possibly, in the course of a season.

If the fuel tank is poorly made and of poor material, it will give more or less trouble of a serious nature. The seams may open or leaks appear which are considered highly undesirable in the present condition of the gasoline market. Furthermore if the tank is not properly supported and installed, there is apt to be trouble. And that is one thing about the fuel tank; generally it goes along attending to business without the slightest trouble, but when it does decide to cut-up it makes a thorough job of it.

Up to a few years ago fuel tanks were made of copper, riveted and soldered. This is an ideal construction. The copper is always clean and takes the solder better than any other metal but the copper tank was expensive not only in material but the amount of labor required.

The material in general use for this purpose today is known as terne plate; sheet steel coated with a composition of tin and lead. This makes a satisfactory construction without the expense of copper.

There are a number of different types of construction used in building modern fuel tanks. In one of these the cylinder of the tank is flanged out at the ends and a convex head is then beaded over and the joint sweated. Another type employs a corrugation in the cylinder of the tank, the convex head with outward flanges being forced in, after which the edge of the cylinder is spun over and the joint sweated. In this latter construction there is no flange on the outside of the tank.

It is getting to be quite common practice to install two or more baffle plates in the fuel tank to direct the flow of liquid. The baffle plates are generally riveted and

soldered into place.

Within the past year or so there has come into considerable use what is known as drawn tanks. This construction may be described as embodying two deep pans joined together at the flange. The great virtue of this construction lies in the ability to produce all sorts of unusual shapes and yet retain the essential strength. Irregularity of form is practically inevitable in tanks for cowl installation, which is considered desirable by many designers. The drawn tank costs more to produce than the built up types.

From the point of view of the car owner about the most important matter in connection with the fuel tank is the method of supporting it. The fuel tank with its full load of gasoline aboard is heavy and it is subject to certain strains and stresses, when the car is traveling at high speed. A rear tank, for instance, must not be supported too rigidly, as in the inevitable heaving of the chassis frame, the joint may be sprung. Perhaps the most satisfactory method of attaching the fuel tank is to use straps or bands of 18 or 20 gauge steel an inch and a half wide and lined with brake



"CLOSE UP" OF THE OLIVER TWO BOTTOM PLOW FOR USE WITH THE FORDSON TRACTOR. THIS OUTFIT IS AUTHORIZED BY THE TRACTOR MANUFACTURER'S AS THE MOST DESIRABLE PLOW EQUIPMENT FOR USE WITH THIS TRACTOR.

lining material or leather to prevent squeaking. In installing drawn tanks the designers have employed bolster plates to keep the supporting straps from bending over the joints which would break them in short order.

A car owner recently had a great deal of trouble with breakage of his fuel tank. There seemed to be no reason for the condition, but investigation showed that the spring clip—it was a rear hung tank—was striking the seam of the tank owing to deflection and sideway as the car traveled.

In dealing with the fuel tank it must be remembered that while solder acts as admirably as a seal between two metals it can not be called on to stand up under severe strain. It is not intended for that purpose. When a leak occurs in the fuel tank the obvious place to look first is at the soldered joints provided the tank embodies that form of construction. The best way of handling seams subjected to strains is by riveting supplemented by solder or by brazing.

In tanks where the gasoline feed tube enters at the top it is desirable to brace it at the bottom so as to minimize vibration. The filler spouts also are better placed in the body of the tank rather than on one of the heads. With the spout on the top of the body no air trap can form which obviates trouble in filling.

Mysterious failure of gasoline to flow to the carburetor can often be traced to the vent hole in the filler cap being stopped up. When this hole gets stopped up a vacuum is created which will hold the fuel in the tank until the vent hole has been cleaned out or the filler cap removed.

CHEAP PAINT REMOVER

Mix one part of turpentine to two parts of ammonia; shake in a bottle until like milk, and apply with a mop of waste or rag. This is more effective than ammonia weakened with water, which is often used. The job must be carefully cleaned of all trace of ammonia before any paint can be safely applied.

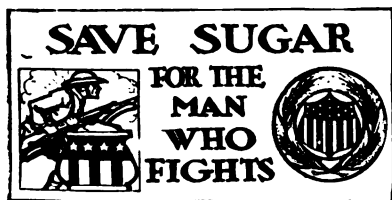

WEIGHTS OF SOFT STEEL—ROUND STOCK PER FOOT.

| Size in inches | Weight per foot pound | Size in inches | Weight per foot pound |
|----------------|-----------------------|----------------|-----------------------|
| 3/16 | .094 | 2 1/2 | 16.69 |
| 1/4 | .167 | 2 5/8 | 18.40 |
| 5/16 | .261 | 2 3/4 | 20.19 |
| 3/8 | .376 | 3 | 24.03 |
| 7/16 | .511 | 3 1/8 | 26.08 |
| 1/2 | .668 | 3 1/4 | 28.21 |
| 9/16 | .845 | 3 3/8 | 30.42 |
| 5/8 | 1.04 | 3 1/2 | 32.71 |
| 11/16 | 1.26 | 3 5/8 | 35.09 |
| 3/4 | 1.50 | 3 3/4 | 37.55 |
| 13/16 | 1.76 | 3 7/8 | 40.10 |
| 7/8 | 2.04 | 4 | 42.73 |
| 15/16 | 2.35 | 4 1/8 | 45.44 |
| 1 | 2.67 | 4 1/4 | 48.23 |
| 1 1/16 | 3.01 | 4 3/8 | 51.11 |
| 1 1/8 | 3.38 | 4 1/2 | 54.08 |
| 1 1/4 | 4.17 | 4 5/8 | 57.12 |
| 1 3/8 | 5.05 | 4 3/4 | 60.25 |
| 1 1/2 | 6.00 | 5 | 66.76 |
| 1 5/8 | 7.05 | 5 1/4 | 73.60 |
| 1 3/4 | 8.18 | 5 1/2 | 80.78 |
| 1 7/8 | 9.39 | 5 3/4 | 88.29 |
| 2 | 10.68 | 6 | 96.13 |
| 2 1/8 | 12.06 | 6 1/8 | 100.2 |
| 2 1/4 | 13.52 | 6 1/4 | 104.3 |
| 2 3/8 | 15.06 | 6 5/8 | 117.2 |
| | | 7 | 130.9 |

Example—To find the weight of 6 feet of 1/2 inch stock multiply the weight per foot for this size which is .668 pounds and multiply by the number of feet, in this case 6 and this gives the total weight or 4.008 pounds which is just a trifle over four pounds.

RADIATOR PLUG

On radiator repair jobs it is necessary that all openings be closed in order to test for leaks and a plug for this purpose can be made as illustrated.

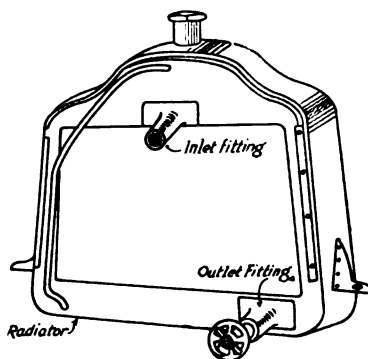

KEEPING WINDSHIELD CLEAR

For preventing windshields from becoming opaque or obscured by heavy rain or snow mix 1 ounce of glycerine with 1-2 pint of turpentine and apply with a soft rag to the glass on both sides.

LESSENING HEADLIGHT GLARE

Dissolve three tablespoonsful of Epsom salts in a pint of vinegar. By holding a cardboard close against the lower half of the glass, the top can be brushed over in a straight line, and so comply with the latest regulations.

WARM ENGINE ECONOMICAL

A warm engine is more economical than a cool one. In act, rom an economy standpoint, it would be advisable to keep the water in the cooling system boiling all the time. The warmer the cooling water is the less heat is absorbed out of the explosions. Consequently it will pay to use a radiator thermometer in connection with a radiator shutter so that the cooling water temperature, which, to be on the sae side, is usually fixed at about 32 degrees below boiling, or 180, or, even better, use a thermostat, which automatically controls the rate o water flow so that the temperature remains constant.

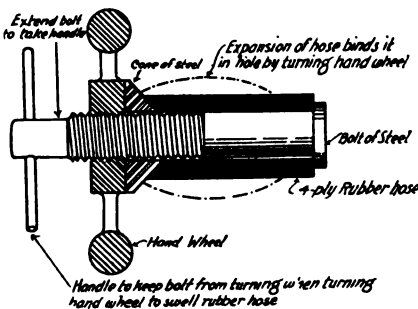

By the use of a device such as this the necessity of soldering and other clumsy makeshifts is eliminated. The plug can be applied or withdrawn in a very few seconds.

THE RED CROSS MAN

The Red Cross man was here today,
He seems to know some magic way,
Of being everywhere;
In Paris when a chap is broke,
He passes out a Yankee smoke,
And at the front, he's there.

He gives us something hot to drink,
He seems to want to make us think,
We're happy and at ease;
He keeps as busy as can be,
Just working for my mates and me,
His method sure does please.

And though he doesn't tote a gun,
We know he's with us everyone,
Till duty sets us free;
His wheeled canteen is far more fair
Than any lobster palace rare,
We drink his health in tea.

—Jeanne Judson.

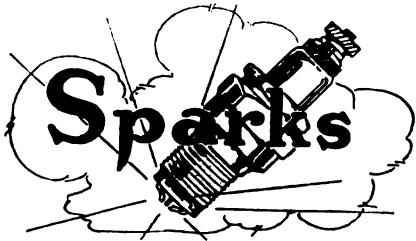

How Long Since You

Saw a "canopy top" buggy?
Marched in a torchlight procession?
Received a pamphlet from the party's
national committee declaring the tariff
to be the paramount issue?
Ate any home-made sausage?
Heard the claim that "this affair in
Europe is none of our affair?"
Chewed any spruce gum?
Saw a middle aged woman riding a
bicycle?
A 20 year old girl blush?
Drank and old fashioned milk-shake?
Listened to "I didn't Raise My Boy to
be a Soldier?"

Hot air may have it uses but it takes
more than that to get up steam.

You never can tell. Many a fellow is
puffed up who doesn't get to the top.

"Let the Women do the Work", used to
be a funny song. It isn't so funny now.

Many a fellow claims exemption who
has lost his sight looking out for number
one.

Now, All Together—Let's get rid of the
habit of saying "after the war is over."
Say "After we Win the War". That
means something.

There's a Russian born every minute.

The Hun has been forced to drop the
goose-step for the Foch trot.

If you have money saved up, buy a
Liberty Bond. If you haven't, buy a
Liberty Bond and save some money.

Writing from France, a Kansas soldier
says that it'll take a year to whip the
Huns and thirty-nine more to wind up the
barbed wire.

The newspapers gravely announce that
Marshal Foch smokes two cent cigars, but
this can't account entirely for the Ger-
man retreat.

Cussin' de weathe'h am mighty po'
farmin'.

One result of "gasless Sundays" is that
Sunday seems like Sunday to those who
are over 20 years old.

Rhine whine is on the menu again.

The Wall Street Journal rises to re-

UNITED WAR WORK FUND

Eight national organizations that
work for the comfort and welfare of
the soldiers are represented in the
campaign,

Young Men's Christian Association.
National Catholic War Council.
Knights of Columbus.

Salvation Army.

Jewish Welfare Board.

American Library Association.

War Camp Community Service.

Young Womens' Christian Associa-
tion.

Think of the misery and privations
that our boys and the men of our
allies are undergoing on the great
battle fields of France and elsewhere
compared to the little that they ask
of you and of the comforts with
which we at home are surrounded—
can you say to yourself "I am tired
of giving?"

Never before has there been such
a consolidation of faith and creed for
unity of purpose—just as the soldiers
on the field think more of unity and
God and less about creed than at
home.

The months immediately following
the end of the war will be more
dangerous to the morale of the men
than the present. Possibly you have
no one of your own in the service but
for the sake of the sons and brothers
of others who are fighting your
battles for you GIVE and give freely
and as much as you can afford—
Whether you are Catholic or Protest-
ant, Jew or Gentile don't let petty
considerations of denominationalism
or prejudice stint your contribution.

All contributions that are received
by the United War Work societies
will be equally distributed among the
eight great organizations listed above.

With the speedy prospect of peace
in sight—possibly a reality before these
lines are read by you, this campaign
is probably the last that you will be
called to help but even if it is not,
give what you can to make things as
cheerful and comfortable to our boys.

We make no apology for devoting
this space to this cause and asking
our readers' fullest cooperation in
this great enterprise.

To have this drive fall short of
producing the amount needed to
carry on this great work would be
nothing less than a tragedy, but with
the help of all of our readers and
their friends, the drive will not fall
short. It will go over the top with
a bang.

mark that "Brewery horses will show up
well hauling guns."

Motto for the gasoline savers, to be
hung on the garage doors so that it may
seen on Sunday mornings; "Don't keep
the home tires turning."

Better leave the sugar in the bowl than
in the bottom of the cup.

Germany's peace offensive will appeal
to us a little better when it has another
object than an offensive peace.

This is one time when the thought that
there may be no Turkey for Thanksgiving
makes us feel cheerful.

General Foch's reputation as a strate-
gist is secure—all the grocery store
strategists agree with him.

"De man dat's always kickin'," says

Uncle Eben, "Ain' got any trouble on
his mind. When real trouble comes you
is generally too stunned to kick."

We Believe it—The average lifetime has
increased three years by sanitation and
science; and the longevity of a suit of
clothes has been increased three years by
the war.

"Save the pits." Surely! and the bot-
tomless one for the Kaiser.

A Kansas newspaper says that the chief
difference between cooties and slackers is
that the cooties are active and are on the
war front.

Nobody cares what happens to the Ger-
mans, just so it happens.

People have more use for a loafer who
minds his own business than they have
for a busybody who is always butting in.

The ringing of a fire bell a half mile
away will get a man out of bed when he
will sleep right through the ringing of a
church bell in the next square.

It isn't the wages that go with it that
makes a man fonder of sin than he is of
behaving.

Every man has enough ego in his make-
up to believe that his wife won the capital
prize in the matrimonial lottery.

There is no logic in calling a man a
liar. But somehow or other, there's a
heluva lot of satisfaction in it.

Dollars to doughnuts is no longer the
big odds it used to be.

The prospect for thrones for all six sons
are growing fainter and fainter.

Next thing we know John Barleycorn
will be willing to negotiate "an honorable
peace."

Even if you don't know who's leading
the German army, you know who's chas-
ing it.

Curiously enough unconfirmed reports
are usually started by confirmed liars.

Yes, the reason they call money "dough"
is because we need it for our daily bread.

Misery loves company. But company
don't always reciprocate the affection so
you could notice it.

They say that troubles drive a man to
drink. Maybe that is the reason a rummy
is always hunting for trouble.

A REAL THANKSGIVING

As these lines are written the world is
rejoicing in the news that peace has been
declared and in the thought that our men
and the men of our allies have been
spared further fighting and that the four
years reign of horror and slaughter, pre-
cipitated by the vain ambition for power
of selsh and unscrupulous monarchs "by
divine right", is at an end.

Those directly responsible for the sor-
row and ruin they have caused have
abdicated or sought safety in flight to
other and neutral countries, while their
erstwhile kingdoms are in the throes of
revolution and are being organized into
republics by their subjects thus freed
from generations beneath the yoke of op-
pression and the heel of virtual slavery.

The people of Europe, not only in al-
lied countries but in all others, have
genuine cause to give thanks. We have
even more cause than they for thankfulness—
we have been spared the agonies
and sorrows of further bloodshed and have
the prospect of a speedy return of our
sons and brothers to their homes.

On Thanksgiving Day, November 28,
when we sit down to our Thanksgiving
feast, we will all, unconsciously, utter a
heartfelt prayer of Thanksgiving for the
blessings of peace that have been restored
to us and—which we now know how to
fully appreciate.

REPOINTING TOOLS

If a mechanic has not high carbon steel tools or high speed tools for lathe or shaper, he can economize to a considerable extent by cutting off the points of the old tools and welding on new cutting points of high speed steel by the oxy-acetylene flame. In this way he has a tool with an excellent point for wear and service without going to the expense of using expensive tool steel for its entire length. Drills of the flat type can easily be repointed by high speed steel, and all hot-punches and cutters used in the forge can be treated by a similar process. This gives you lower priced tools having all the advantages of high speed cutting edges. Weld on the tool point by the flame, then dress it up and grind to shape.

TEMPERING A ROCK DRILL

The dressing of a rock drilling bit is a job that the country blacksmith is often called upon to undertake. Usually the size of the bit is determined by use of a ring gauge. In heating the end to dress the bit should be turned occasionally to get an even heat. Bring it to a cherry red for three of four inches back from the end. The bit is usually spread with the sledge, working from the center to the edges, making the diameter a little larger than the gauge, then hammering down to the proper size. It is not necessary to make the edge very sharp, or it will tend to drill a three-cornered hole.

For hand cutting drills the hardening must be good, but should not extend very far back from the cutting edge, while there should be plenty of clearance on the corners of the bit. Form the cutting edge by drawing down a very short taper, and then gradually round it towards the extreme cutting edge. Plenty of clearance should be given to the tool. In tempering the end is heated until it shows bright cherry red in the shade, then place upright in $1\frac{1}{2}$ or 2 inches of water, so as to cool only the part to be tempered. After a minute or two, when the edge is cool, the bit is removed until the heat flows back into the end and causes it to pass through straw, orange and purple to a blue color. It is then re-immersed and allowed to cool. The treatment gives the proper temper for drilling moderately hard rock. Always keep the taper short.

LUBRICATING VALVE STEMS

The exhaust valve stems are extremely likely to stick because of the formation of a gummy deposit that comes in this part. Gasoline or kerosene are the only things that will help much in these circumstances. By inserting a bit of copper tubing in at the next spark plug hole, a little gasoline may be squirted onto the valve stem. The gasoline runs down the stem and quickly loosens the gum, so that the valve stem is free to move again.

TO HOLD SCREWS

It frequently happens that a screw is so located that a lock nut, cotter-pin or the usual devices cannot be used to hold it. By cutting a short length of iron wire, bending it a little and then, after the screw has been sunk under the surface, drive the wire in so that it lies in the slot, the screw will be firmly held in place.

A GLUE SUBSTITUTE

In making up a sand belt for the wood shop the scarcity and high price of glue can be overcome by the thought that "water glass", or silicate of soda, will do equally well. This preparation makes a good glue substitute.

WATCH THE AMMETER

Watch the ammeter on the dash as it puts you in close touch with the whole system. Find out what each set of lamps uses in the way of current, and you have a basis for your observations.

If ammeter needle shows more discharge than the lamps usually require there is a short-circuit on some lamp wire. Find it immediately as it may ruin the wires or battery, or may even set the car on fire.

If ammeter shows "discharge" when lamps are not turned on it shows a short-circuit on some other part of the wiring.

If ammeter shows nothing when engine is running at 15 to 20 miles per hour, it shows that generator is not delivering current; automatic cutout is not working, or that ammeter is defective.

If ammeter shows nothing more than engine is running at normal speed, it shows that the voltage regulator is not correctly adjusted. Study the ammeter, learn to read its indications and you will get best results.



ENAMEL GLAZE FOR COATING IRON PANS

To prepare an enamel glaze for coating iron pans use flint glass, 130 parts; carbonate of soda, 20.5 parts; boracic acid, 12 parts. Dry at a temperature of 212 degrees and then heat to redness and anneal, that is, cool down very slowly.

SOLDERING PASTE FOR COPPER WIRES

Soldering paste has come into extensive use in electrical work as a flux for soldering, and the following recipe will be found useful in soldering copper wires when the use of an acid would be objectionable. This paste will not spatter or corrode, and the proportions are as follows: Saturated solution chloride of zinc, one dram; vaseline, $1\frac{1}{2}$ ounce.

WHITE BRAZING SOLDER

A white brazing solder which may be used with good results on iron or steel, consists of copper 45 per cent, zinc 45 per cent, and nickel 10 per cent. The use of the small quantity of nickel in the mixture gives the necessary whiteness and increases the melting point but slightly. In brazing steel or iron, silver solder, which flows readily without oxide and at a low temperature, is much preferred, but due to its expensiveness sometimes makes a suitable substitute desirable.

ALLOYS FOR DRAWING COLORS ON STEEL

Alloys of various composition are successfully used for drawing colors on steel. To draw to a straw color use 2 parts of lead and 1 part of tin, and melt in an iron ladle. Hold the steel piece to be drawn in the alloy as it melts and it will turn to straw color. This mixture melts at a temperature of about 437 degrees F. For darker yellow use 9 parts of lead to 4 parts of tin, which melts at 458 degrees F. For purple, use 3 parts of lead to 1 part of tin, the melting temperature being 482 degrees F. For violet, use 9 parts of lead to 2 parts of tin which melts at 594 degrees F. Lead without any alloy will draw steel to a dark blue. The above apply to steel only since iron requires a somewhat greater heat and is more or less uncertain in handling.

FLUX FOR BRASS

One ounce common soap, $\frac{1}{2}$ ounce quicklime $\frac{1}{4}$ ounces saltpeter. Mix into a ball and place in a crucible when lifted out of the furnace. This is sufficient for about 50 pounds of metal.

TO BLACKEN ZINC FOR LAYING OUT

This receipt of course is the same as that often used for coating iron or steel but it is not generally known among many of the craft that it may be used to prepare zinc for sketching, giving the zinc a dark coating. Dissolve 1 ounce sulphate of copper in 4 ounces water, add $\frac{1}{2}$ teaspoonful of nitric acid and apply a thin coating to the zinc with a piece of waste. If used for iron or steel the work should then be rubbed dry. Care should be taken in handling and using the mixture, as it rusts iron and steel badly if left on.

TO WRITE ON CELLULOSE

To write on triangles or other instruments made of celluloid use anhydrous acetic acid. The writing will appear dull on the shining surface. If colored writing is desired add some coloring matter to the acid.

How It's Done

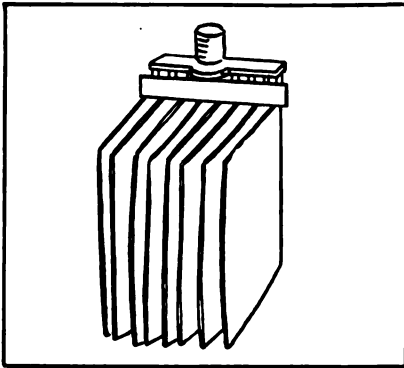

15—Positive group showing buckled plates. A group of buckled plates which, when reassembled, will not go into the jar readily should be replaced with a new group.

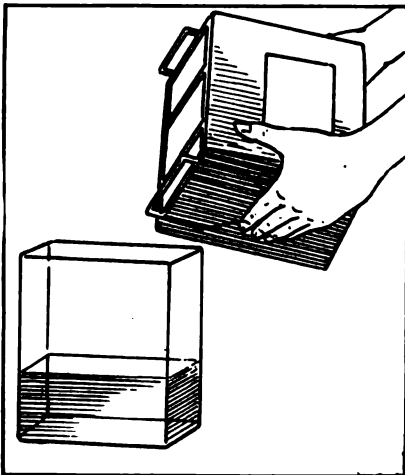

16—Having examined the groups, pour the electrolyte into a large jar or vessel. A glass jar is best adapted to the purpose so as to disclose any sediment which will settle at the bottom. Sometimes impurities get into the electrolyte, and as a precautionary measure it is not advisable to use the old solution.

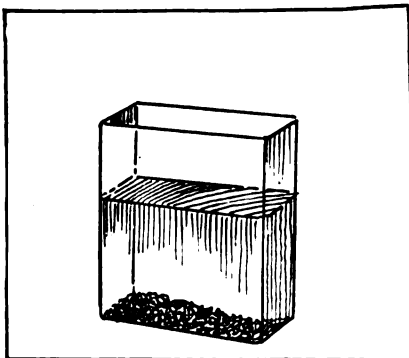

17—Note the sediment which has settled at the bottom of the jar containing electrolyte. Under normal usage this sediment will not be considerable. A large amount of it indicates that the cell has been

overheated, and that the solution has not been kept above the plates by adding distilled water at regular intervals.

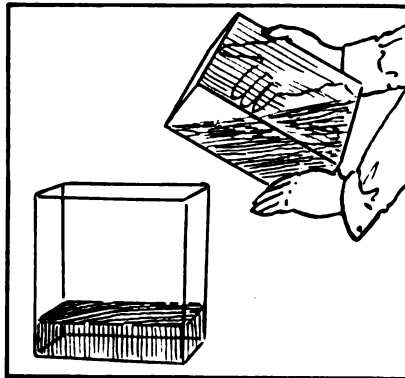

18—This shows the pouring off of the clear electrolyte. Never allow the sediment to get into the battery as it would impair the efficiency of the separators.

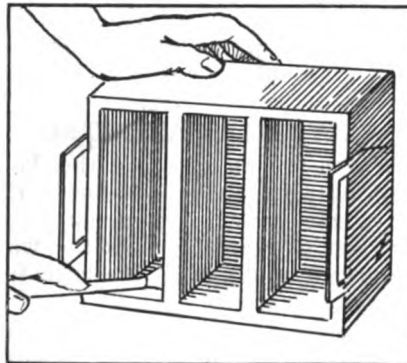

19—Invert the case over a sink and thoroughly clean the cells by inserting a hose and injecting a stream of water upward into each cell. Be sure that all sediment and foreign matter is removed from the cells before installing the plates.

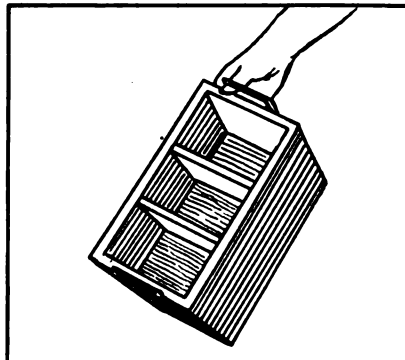

20—Inspect the jars carefully for

cracks or other imperfections. Jars exhibiting such defects should be replaced with new ones.

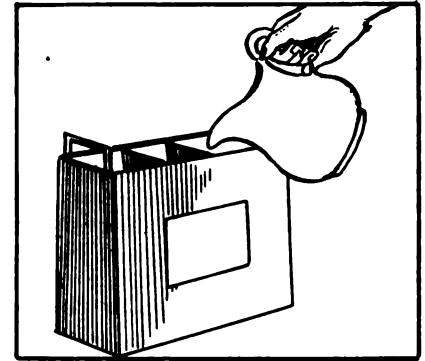

21—To remove a jar, fill it with boiling water and allow it to stand for a least five minutes. This will loosen the sealing compound surrounding the jar.

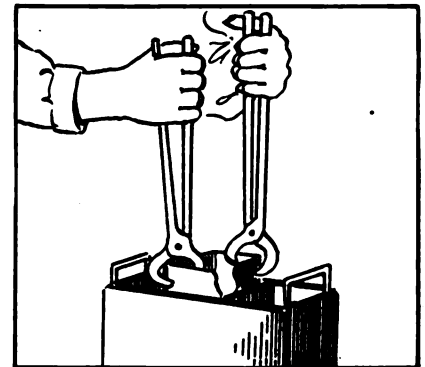

22—Grasp the edges of the jar to be removed with two pairs of pliers as illustrated and pull straight up. Care should be exercised so as not to damage adjacent jars.

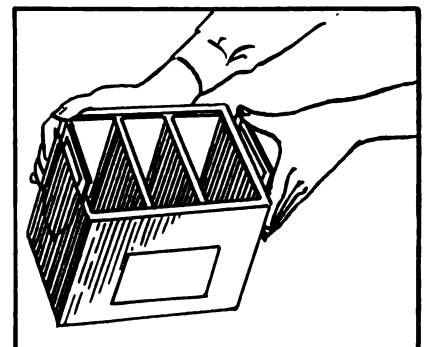

23—Before putting in a new jar, examine the space in the case and remove the shims and sealing compound so as not to hinder the jar from being placed properly.

Tearing Down, Repairing and Assembling Automobile Starting and Lighting Batteries Part II.

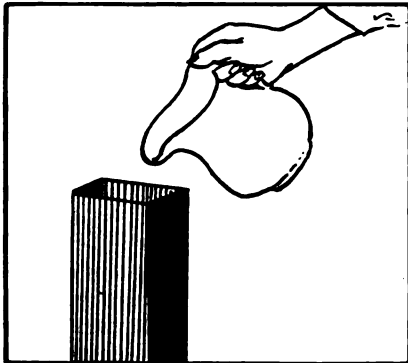

24—The jar should be heated before being placed in the case. This may be accomplished by pouring boiling water in the jar. If hot water is not available, play a light flame around the outside of the jar.

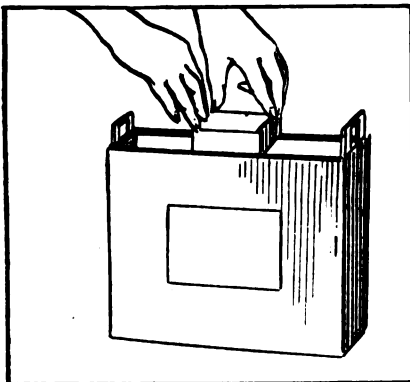

25—When the jar has been heated it should be pushed into place taking care to see that the top of the jar is level with the others. If the tops are not lined up, the top connectors will be uneven, and as a result present a very poor looking job.

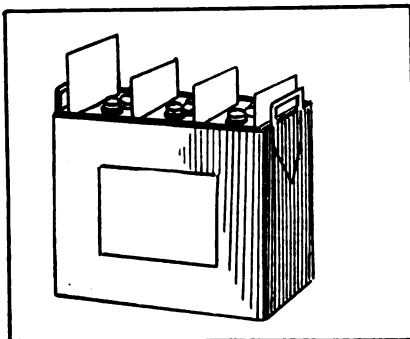

26—To secure the proper spacing and a tight fit, place a paraffined wood veneer shim between the jars.

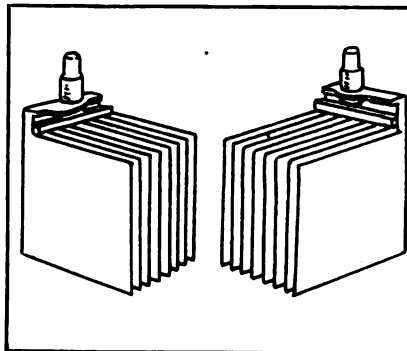

27—To replace an element the first step is to take the positive and negative groups of a clean, flat table. Always make sure that the work table is free from lead scrapings or foreign substances of any kind as these substances adhere to wet separators, and if not removed will cause short circuiting of the plates.

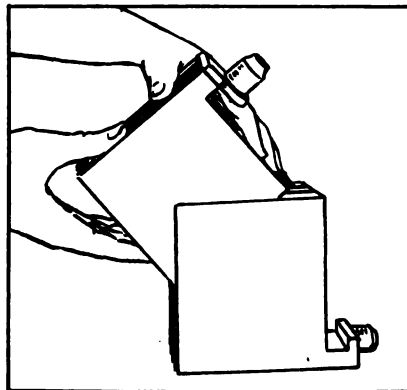

28—Intermesh the positive and negative group. As the negative group contains one more plate than does the positive, both outside plates should be negative.

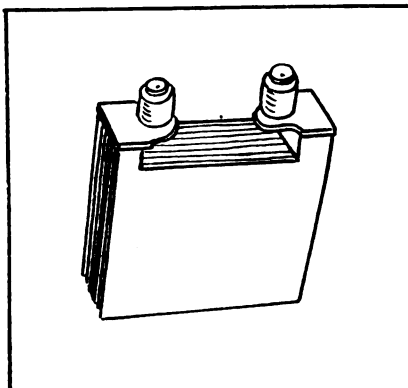

29—This illustrates a complete element ready to receive separators.

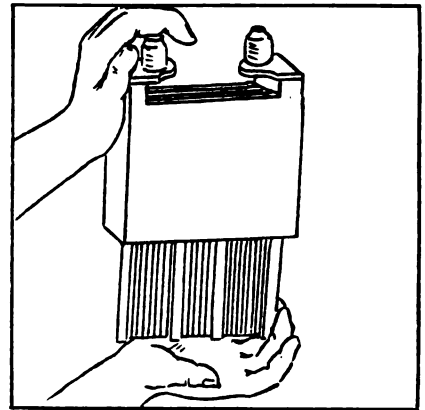

30—Lay the element on its side and put the separator retainers in position. Insert the separators between each pair of plates. If wood separators only are used, the grooved side of the separator should be next to the positive plate. If wood separators and rubber sheets are used, they should be inserted together the rubber sheet between the positive plate and the grooved side of the wood separator. See that the separators are against the retainers and that they extend equally on either side of the element. Carefully check up separators after assembling as to omit a separator would cause considerable trouble.

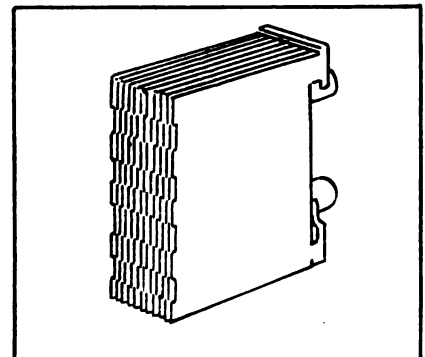

31—A complete element. Grasping the element by the pillar posts, lower gently into the jar. This should be done very carefully to avoid breaking the jar.

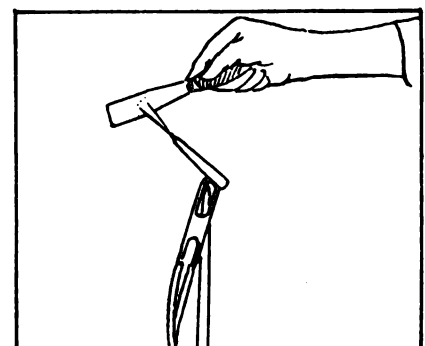

32—To clean the covers, heat a putty knife.

Chevrolet "490" Electric System

M. H. GEORGE

AUTOMOBILES are generally divided into three groups, low priced, medium priced and high priced and naturally enough it is the low priced cars that are the most popular and in this class we can consider the Chevrolet Model "490". There's a reason for everything and the reason for the name "490" comes from the fact that this car was designed and built to sell for \$490. Until the era of high prices set in this was the selling price of this car and although the price is somewhat more today it still remains Model "490."

In this article it is our purpose to describe briefly the electrical system of this car so that the repairman will know where to look

ing the storage battery (under the floor boards on the driver's side) is attached to the dash.

The ammeter on the instrument board or dash, indicates how much current the storage battery is receiving or discharging. No discharge will be indicated when the starter is in operation as the discharge is so heavy that a heavy instrument would be required to record it. When the lights are turned on the pointer will go to the right. When the engine is running at a fair speed and no lights are burning the hand will point to the left. If the car is standing still and everything is as it should be the pointer will stand at zero. If at any time the ammeter shows any discharge when

the engine is not operating and with no lights burning there is "something loose" somewhere that had better be investigated unless one isn't particular about such a little thing as a dead storage battery.

The generator is quite simple and aside from an occasional drop of oil in the bearings every 500 or 600 miles requires little care. New brushes can easily be installed by removing the commutator cover by taking off one screw. The generator is driven from the engine crankshaft and as it is in a constant oil bath it needs no oiling or greasing at this point.

The voltage output is controlled by what is known as the third brush regulator and does away with mechanical governors which are apt to cause trouble. This brush increases or decreases the field strength in proportion to the motor speed. When the car is going at the rate of about six miles per hour the ammeter should show charge and when the car is going at twenty-five miles per hour the ammeter shows about fifteen amperes. Keep the terminals tight around the generator. When the brushes become worn out they can be replaced by removing the cover that is over the commutator and is held in place with one screw. If the

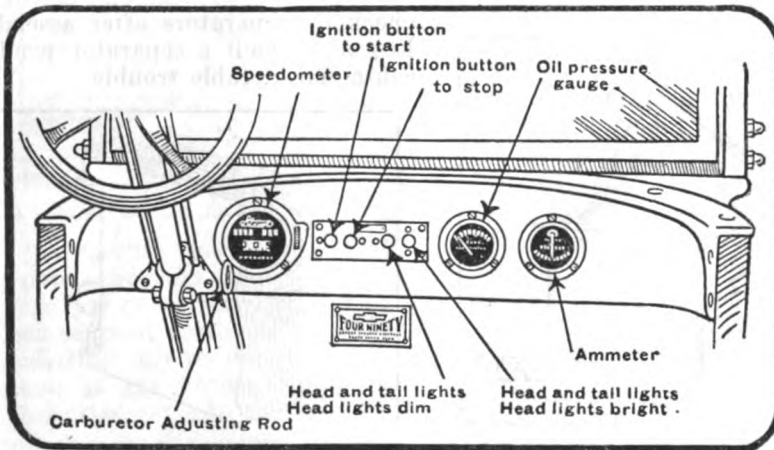

"490" INSTRUMENT BOARD

for the "bugs" when they show up.

The popular Auto-Lite starting and lighting system is used and is of the two unit type, having separate starting motor and lighting generator. The generator will be found at the front on the right hand side of the engine and is secured in place with four bolts which make the whole easily removable if it should be necessary to remove the armature or make other repairs or adjustments.

The starting motor is also on the right side of the engine but at the rear. The circuit breaker that opens and closes the charging circuit from the generator and prevents current from flowing back through the generator and exhaust-

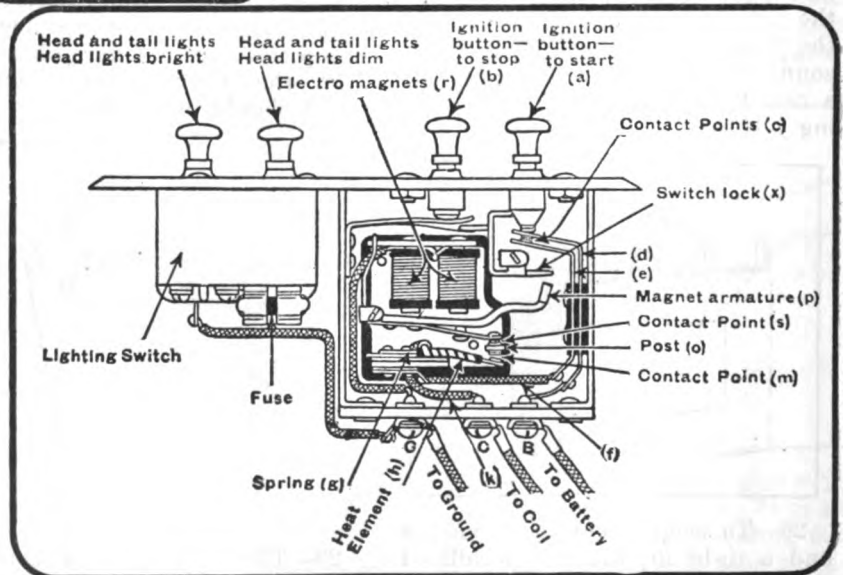

IGNITION SWITCH AND AUTOMATIC CUT-OUT

commutator is dirty or black it should be cleaned with a piece of very fine sand paper held against the commutator with a flat stick, have the engine turning very slowly. If the commutator is worn down and is grooved it should be

minimal posts of the generator. Be sure and remove this when the battery is replaced. If there is trouble with the generator windings or trouble of that kind about the only thing to do is to return it to the manufacturer. If the generator is

the inside and an eccentric weight, this weight keeps the pinion at the end of the shaft next to a coil spring. This weight also keeps the pinion from turning and consequently it must move along the threaded extension, as it moves along it engages the teeth on the flywheel and comes to a stop at the end of the sleeve. It is now fully meshed with the teeth on the flywheel rim. Over the end of the armature shaft is another shaft, held to the shaft with a clamping bolt. The two sleeves are connected with a heavy coiled spring. When the pinion reaches the stop it must begin to turn the flywheel. Of course there would be quite a shock that would be apt to break the teeth out of the gears, this spring acts as a shock absorber, by coiling up until the torque of the starting motor overcomes the re-

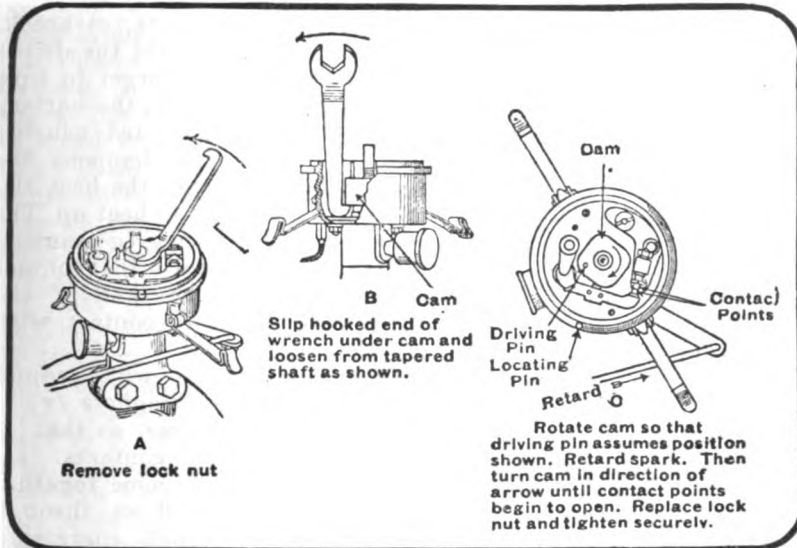

TIMING IGNITER

taken out and turned smooth in a turning lathe. After turning the commutator be sure that there is no dirt or pieces of metal that bridge across the copper segments, and it is well to scrape the insulation down so that it is lower than the copper, a three cornered file or a hack saw blade that is broken off and thinned will do very nicely.

The springs that hold the brushes against the commutator should have tension. Sometimes they get so that there is not much tension and if they are too weak new ones should replace the old ones. See that the brush holders are insulated from the generator case, and if any of the insulating plates or bushings should be worn or broken

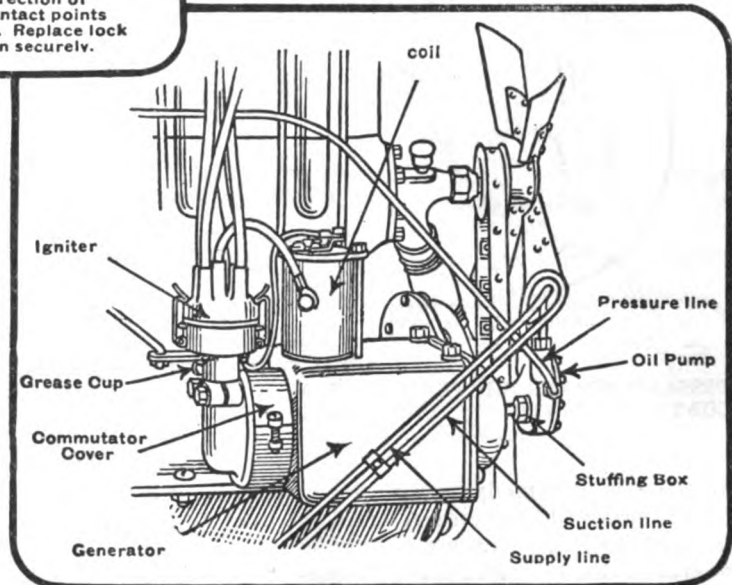

GENERATOR AND IGNITION SET

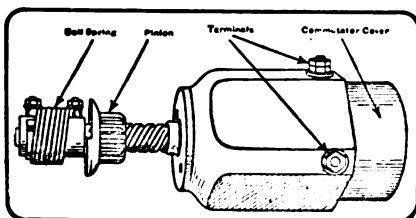

"AUTO-LITE" STARTING MOTOR WITH BENDIX DRIVE

they should be replaced. If the battery is disconnected or taken out of the car the engine should not be operated. If it is necessary to operate the car with the battery out, a short piece of copper wire should be placed between the tr-

threads. The pinion has threads on out do not use the starting motor as the storage battery will soon be run down as there is nothing to recharge it. The bearings of the starting motor should be oiled about the same as the generator. Do not oil or grease either commutator or the brushes, as it is not needed.

The starting motor has what is known as the Bendix drive and operates as follows,—On one end of the motor shaft is the commutator, and at the opposite end is a pinion, which automatically engages the toothed rim of the flywheel when the motor armature is rotated rapidly, as in starting. On the shaft of the motor is an extension or sleeve that has square

sistance of the engine and starts to revolve the flywheel. When the engine begins to revolve under its own power it goes at a much higher speed than it did when it was being turned with the starting motor this, of course, increases the speed of the pinion, but it is running faster than the threaded sleeve, and it will be screwed on the threads of the sleeve like a nut on a bolt until it has screwed out of mesh with the flywheel gear. If the operator forgets to remove the foot from the starting switch button, the unbalanced weight of the pinion causes it to twist on the threaded sleeve and clutch the threads, preventing it from meshing with the flywheel gear. The starting motor and the Bendix drive

should be examined to see that every thing is tight. If the spring gets out of shape it should be replaced and if it is broken it should not be used as it will cause trouble. The brushes can be replaced on the starting motor the same as in the generator.

The circuit breaker is automatic in its action and requires no lubrication, but it should be looked at once in awhile and if the points get pitted or rough they should be filed smooth with a very fine file. Sometimes the points stick together when the generator stops charging and allows the current to flow back from the battery. If it is not discovered in time it burns the wires in the coil in the circuit breaker

tory, but through neglect and use they will go wrong and then there is trouble. The instruction books quite often say that "this is properly adjusted at the factory and should not be tampered with", this is good advice and I agree with them, but, I have known of a number of cases where these same things have been examined and found wrong and repaired which I do not think that every man should dig

ing through the spring (g), flows through the heat element (h) and wire (k) to the terminal C, then to the coil. The ignition is turned off by pressing in on the button (b) which releases the switch lock (x) permitting the button (a) to return to its normal position, which in turn opens the contacts (c) breaking the circuit. Should the driver stall the motor and forget to turn off the ignition switch, the battery would be short circuited causing trouble. When this happens the current flows through the heat element (h) causing it to heat up. The heat acts on the spring (g) causing it to straighten until the contact (m) mounted on the end of the spring comes in contact with the post (o).

One end of the wire wound around the electro magnets (r) is attached to the frame, so that as soon as contacts (m) and (o) come together current flows through the magnets, energizing them so that they exert a magnetic pull upon the armature (p). As soon as this pull becomes strong enough

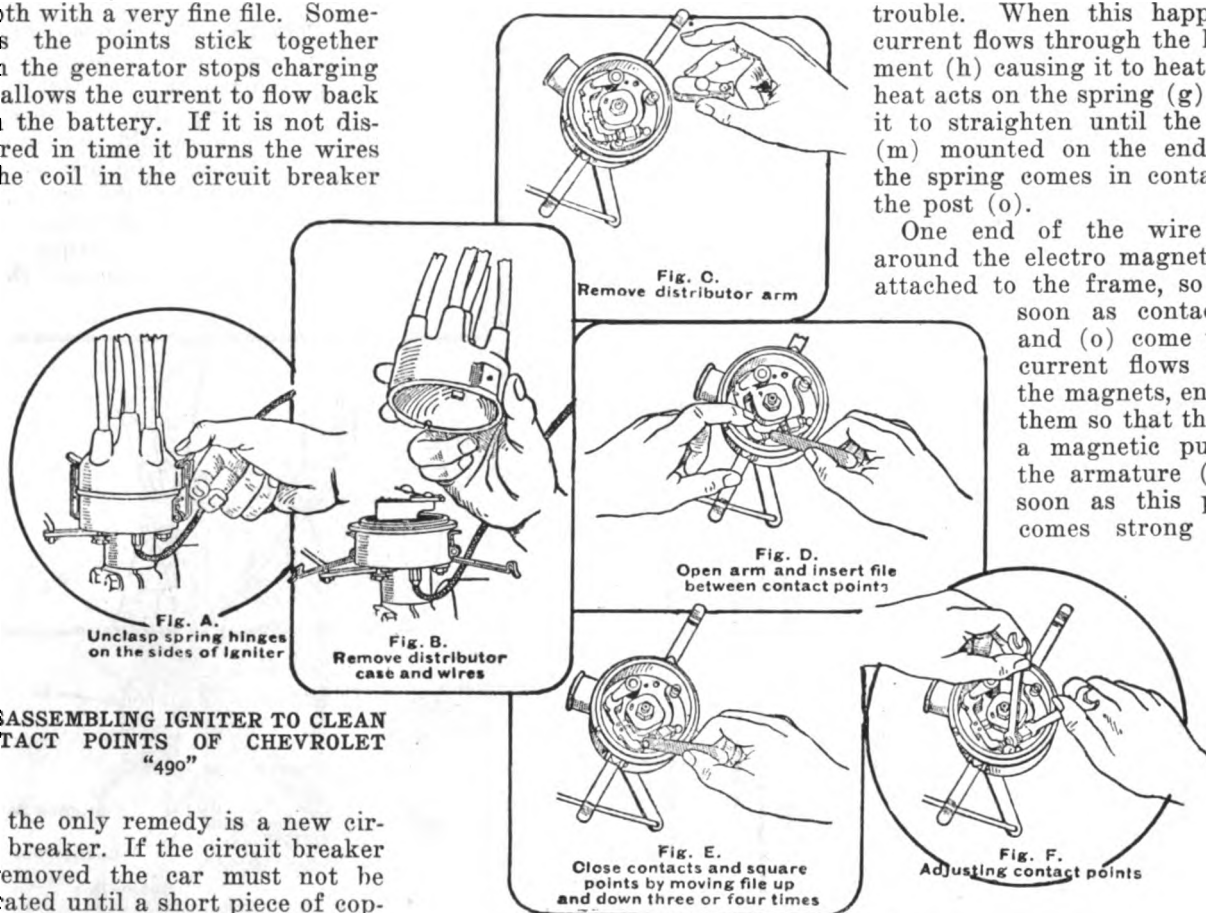

DISSASSEMBLING IGNITER TO CLEAN CONTACT POINTS OF CHEVROLET "490"

and the only remedy is a new circuit breaker. If the circuit breaker is removed the car must not be operated until a short piece of copper wire is connected between the two terminal posts of the generator.

The ammeter is not supposed to give any trouble, but sometimes the hand sticks and does not read right. Sometimes a short circuit will bend the hand and it will not stand at zero. To test it to see if it stands right, remove the wires from the ammeter terminals or the positive wire from the storage battery. The ammeter hand will now stand at "zero". If for any reason it is necessary to remove the ammeter and operate the car without it, the two wires which were attached to the ammeter terminals should be fastened securely together and wrapped with tire tape.

Of course all of these different things are supposed to be all right and are when they leave the fac-

into them but a man that is honest will not touch a thing that he does not understand.

The lighting and ignition switch is in an insulated box on the instrument board and it usually needs no attention.

The ignition switch is turned on by pushing in on the button (a), this closes the contacts (c), causing the current to flow from terminal B, along the flat spring (d), through the contacts (c), returning through the flat spring (e) and wire (f) to the spring (g). This spring (g) has a heating element wound around it (h), one end is fastened to the spring (g), this heating element (h) except where it is fastened from it with suitable heat-resisting material. The current after pass-

the armature (p) moves upward toward the poles of the magnets. This action causes the free end of the armature to strike the switch lock (x) which releases the button (a) and in turn opens the contact points (c) breaking the circuit. The contact point (s) rests against the post (o) when in normal position, and acts as a bumper when the armature (p) is released from the magnets. This instrument is called a circuit breaker and its purpose is to prevent the battery from being shorted and spoiled. The driver should always try and remember to switch off the ignition as continual use of the circuit breaker will injure it. Some times the switch will fail to work, if this happens loosen the screws that hold it to the instrument board and pull the switch out, the cover

can then be lifted off. To test for trouble disconnect the wire (C) from the switch and take a long piece of wire and attach one end to the negative terminal of the storage battery. Push the button (a) and touch the free end of the wire to the spring (e) and make and break the circuit, if a spark is seen at the contacts (c) they are in good shape if not it should be repaired.

If these are all right test the heat element (h) by bringing the free end of the wire up to the terminal (C) and make and break the circuit. If there is not a spark at this point, there are three things that may be the trouble, The heat element (h) may be unsoldered from the spring (g), The heat element (h) may be burned out, the wire (k) may have become unsoldered. If the wires are unsoldered they can be repaired easily, but if the heat element is burned out it will have to be sent to the service station for repairs. A temporary repair can be made so that the car can be used but extreme care must be used when stopping the car to switch off the ignition, or the storage battery will be ruined. A short piece of wire can be soldered from terminal (C) to the spring (e). Some times the circuit breaker will fail to do its duty, and the cause may be poor contact between post (o) and point (m) or the electro magnets may be burned out. To safeguard the lamps a small fuse is placed in the line. If this should blow a new one will have to be inserted. Before doing this it will be well to see that the cause of the trouble is removed. A great many people, I find, do not know what a short circuit is. Any electrical trouble is a short

circuit, to some, but a real short circuit is where any two wires of opposite polarity come in contact at bare places or with any metallic conductor. This will very soon run out the battery and may cause other damage, and for this reason great care should be taken to see that all connections are tight and that the insulation on the wires is in good shape. If at any time the ammeter hand stands at discharge when the light switch is off and the engine is idle, it would be well to disconnect one of the wires from the storage battery, if the hand goes back to zero, you will know that there is a leak or a short circuit. No time should be lost in trying to find it and have it fixed. Some times the ammeter hand gets bent and will not go back when the wire is disconnected.

If at any time one thinks the generator is not generating, place a screw driver across the terminals of the generator. If there is a bright hot spark, you may be sure it is not the generator that is at fault. If the generator does not generate, see that all the connections are tight, and the commutator is clean, that the brushes are making good contact, that there is spring tension on the brushes and see that the mica insulation between the segments is not higher

then the copper, if it is it must be filed down lower. If the generator is generating be sure that everything is tight and all the connections are clean, and the circuit breaker is working, also that the ammeter is doing its duty, turn on the lights and see if the ammeter shows discharge. These same rules apply to the starting motor if it fails to crank the motor.

THE STEEL THAT GOES IN AUTO SPRINGS

Definition of Steel.—If there is less than 2.2 per cent. carbon in the molten solution, then upon cooling.

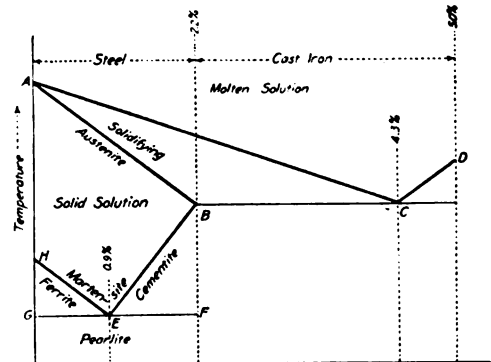
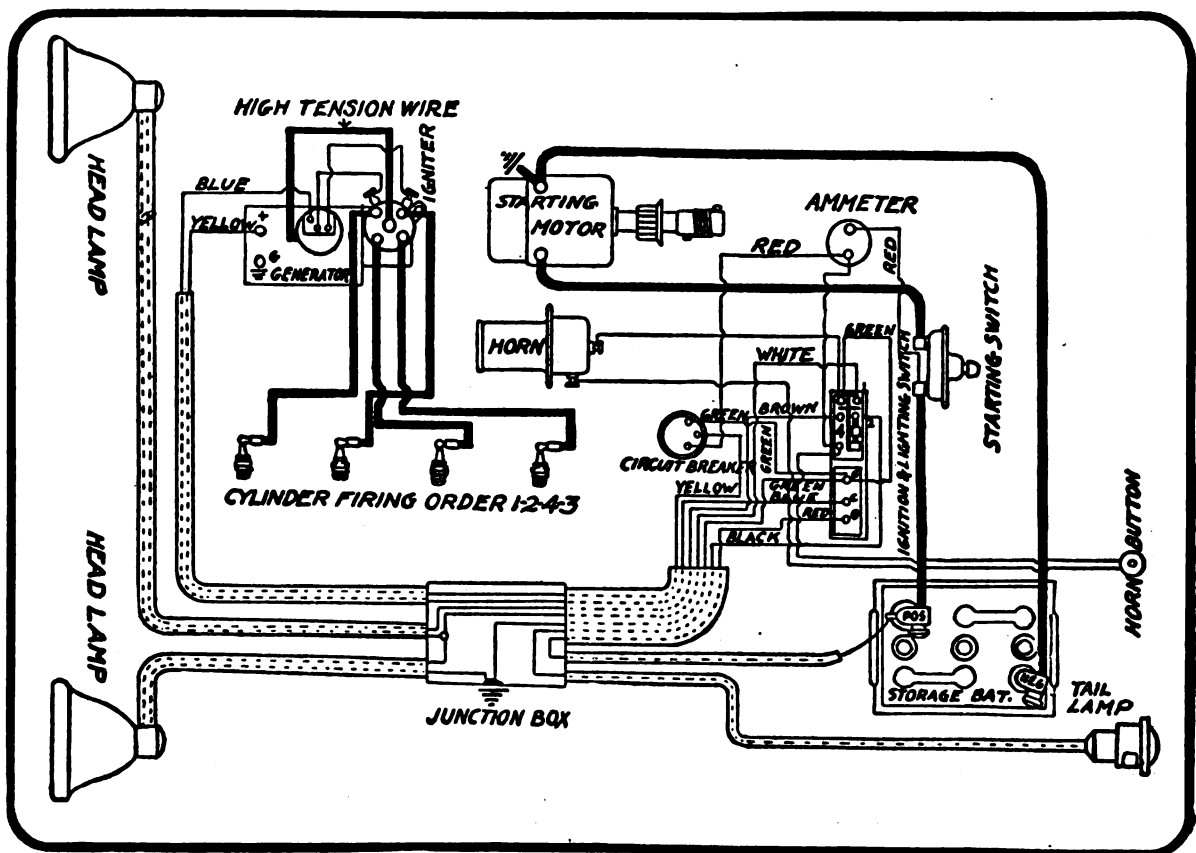

FIG. 22

the mass solidifies without change; that is, we have a solid solution of carbon and iron in the same proportion as it was in the molten



CHEVROLET "490" WIRING DIAGRAM

state. Therefore, 2.2 per cent. is the maximum amount of carbon that can go into solid solution with iron and this limit has been chosen as the dividing line between steel and cast iron; that is, iron with more than 2.2 per cent. carbon is cast iron, and with less it is steel.

The temperature at which steel begins to solidify or freeze depends upon the amount of carbon present, decreasing with increase in carbon content. Furthermore, the temperature at which freezing is completed also decreases with increase in carbon. These relations are shown in Fig. 22.

As we cool the solid solution of iron and carbon, we finally arrive at a temperature where a marked structural change takes place, the nature and magnitude of the

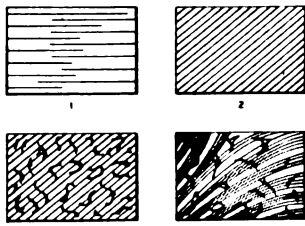

Fig. 23

change depending upon the percentage of carbon in the solid solution.

To take a concrete example, let us assume a 0.5 per cent. carbon steel; then when it has cooled to about 760 deg. C. (see Fig. 22), a change in structure will take place. The solid solution of carbon and iron will lose pure iron by separation. This pure iron is called "ferrite." As the temperature sinks the separation of ferrite will continue until the carbon content of the solid solution has reached 0.9 per cent. which corresponds to a temperature of about 690 deg. C.

At this temperature the 0.9 per cent. carbon solid solution becomes what is known as pearlite. In this condition the steel then consists of a mixture of ferrite (pure iron) and pearlite (an eutectoid of ferrite and cementite).

An idea at least of these changes may be gained from the rough sketches in Fig. 23, which indicate the various stages of the process. Referring to Fig. 23, 1 represents a solution of carbon and iron; 2 represents a solid solution in the same proportion; 3 represents particles of pure iron or ferrite. In the solid solution, 4 represents particles of ferrite mixed with a stratified eutectoid formation of

ferrite and cementite, known as pearlite.

If we had used a solution with more than 0.9 per cent. carbon the action would have been just the same, except that when we struck the critical temperature line EB, cementite instead of ferrite would have been separated out of the solution until the carbon content of the remainder had been reduced to 0.9 per cent. This 0.9 per cent. constituent, as before mentioned, is pearlite.

Ferrite is relatively weak, soft, ductile and malleable; while cementite is hard and brittle. In distinction from a mechanical mixture, cementite is a chemical compound known as iron carbide.

Pearlite is an eutectic alloy, of ferrite and cementite, and consists of an intimate conglomerate mixture of these two substances.

Martensite is the constituent which confers hardness on steel and corresponds to the maximum hardness obtainable by carbon alone.

Sorbite and Troostite are conditions of molecular structure whose exact chemical composition is uncertain. They are structures intermediate martensite and pearlite, and in physical properties are also intermediate these last two.

Each one of these various structural forms of steel at different temperatures can be caught and retained to a more or less perfect degree by cooling it so fast that it does not have time to change from one form to another. Therefore, by heating to a given temperature and cooling at a certain rate, we are able to give the structure of the steel any one of a great variety of forms that result from the combination of different amounts of the different structures. Therefore the resulting properties of steel depend largely upon the proportion of these various forms in the structure and upon the fineness and closeness of the crystals.

To illustrate in an elementary way what happens, let us take a piece of carbon steel having about 1 per cent. carbon and heat it steadily, following the temperature with a recording electric pyrometer (or high temperature thermometer) that draws a temperature curve, as in Fig. 24, which shows simply the pointer of the pyrometer drawing a line on a steady moving paper. As the temperature increases the pointer swings upward.

At first the temperature rises

steadily along the line AB until it reaches B, where it stands practically still for a time, and then begins to rise again at C. To study the effect of heating at these various temperatures, let us remove the steel at different points and quench it in cold water. Doing this, we note that heating it to any point below B does not affect its properties, but that if we heat it above B and then chill it quickly, we obtain a steel hard enough to scratch glass and so brittle that it will fly to pieces under a blow from a hammer.

Going further, we find that the more we heat it above B the coarser is the grain and the less the cohesion between the crystals or particles; that is, the less the strength of the steel. Therefore, point B represents a critical temperature of tremendous importance, since it vitally affects the quality of the steel.

Studying the curve in Fig. 24 it is evident that the heat supplied to the steel is used to raise the temperature of the mass steadily, until the point B, at about 700 deg. C., is reached, when some change takes place within the steel that absorbs the heat and makes the temperature stand still. This critical point B is called the "decalescence point" because here we have the equivalent of a cooling effect.

If, after heating above C, we should allow the steel to cool slowly, then when the point C at about 690 deg. C. is reached the temperature suddenly stops falling, and continues practically constant until B is reached, when it again resumes its continuous fall. Thus it is evident that at this temperature we have a reverse of the change noted above before and that this change releases the heat that was before absorbed. This point is called the "recalescence" point because it has the effect of "heating up."

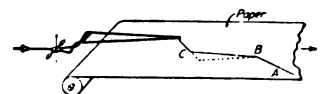

Fig. 24

In practice, the decalescence point, lies above the recalescence point, because upon heating, the temperature rises above its true critical value before the change has time to begin. This same phenomenon can be observed by carrying a mass of water through the freezing point. If water is kept

perfectly quiet it may be quickly cooled to, as low as 28 deg. F. before it freezes, while upon thawing it will always rise to 32 deg. F. before beginning to melt, and as is well known the temperature of a mixture of ice and water remains at the freezing point as long as there is either a drop of water or a particle of ice in the mixture; that is, it can neither rise nor fall until the change from ice to water or from water to ice is complete, and a pyrometer (thermometer) recording this temperature would make a record quite similar to that shown in Fig. 24.

Extremely rapid chilling or quenching of steel from above the critical temperature forcibly retains the structure corresponding to the higher temperature and thus requires the continuous exertion of molecular force, which makes itself perceptible to us as brittleness. We can imagine the internal state here present if we think of a ring of children running around as fast as they can. Just as soon as the weakest one in the ring is forced to let go the whole ring flies apart and all pull between them is released. Thus in a brittle piece of steel every particle in the structure is pulling with all its might against each of its neighbors, and when a sudden load, such as a sharp blow from a hammer, is applied the particles in that neighborhood give way and let loose of their companions, which immediately fly apart, thus equalizing all stress and incidentally completely disrupting the steel.

In order to relieve these internal stresses harmlessly it is only necessary to reheat the steel to a moderate degree and let it cool slowly. This is called "tempering" or "annealing." The same purpose may be accomplished by slow cooling from the critical temperature, but in practice, while slow cooling is cheaper, reheating is more susceptible to accurate control and hence produces a more uniform and high-grade product.

Heat Treatment Principles—Summing up what we have just said, there are a few facts that stand out prominently:

1. To change the structure of steel from a form corresponding to ordinary temperatures to that of higher temperatures, it is necessary to heat it to its "critical point" or higher. No temperature below this will produce a change.

2. Steel that has been heated above the critical temperature will retain a structure corresponding to that temperature, if chilled immediately.

3. Steel that has been heated above the critical temperature can be given any structure between that point and ordinary temperature by combining the correct amounts of rapid chilling and slow cooling.

4. Steel that has been heated above the critical temperature and quenched can be released to a greater or less degree into its lower temperature forms by a certain and definite amount of moderate heating and slow cooling.

ANNEALING METHODS

There are a number of methods used in annealing steel and for the benefit of those who can use them, I give two of the best methods that I know of.

Heat the steel slowly and evenly to a cherry red and bury it in air slaked lime, letting it remain until cool.

The second method is what is known as "water annealing" and is a quick way to soften steel. This method has been used by very few mechanics as it is not an easy matter to tell when the steel is at the proper heat to plunge into the water. Heat the steel to a cherry red and rest the steel across two pieces of iron so that the air will circulate all around and allow it to cool evenly until the proper heat is obtained. This is ascertained by sprinkling pine sawdust on the steel as a test.

The sawdust should be very fine and dry and when the steel has cooled down so that it looks black in an ordinary bright day, or a little red on a dark day, then test it with the sawdust and if it burns off quickly, wait until it has cooled a little more, testing occasionally with the sawdust. When the steel reaches a heat that caused the sawdust to smoke and disappear, it is ready to be cooled off in water.

W. H. Mitchell, Indiana.

CHISELS FROM FORD MAGNETS

Just now good tool steel for chisels and such purposes is not only scarce but very high priced. I have discovered that the old magnets of a Ford magneto are made of a fine grade of steel and I have made quite a number of chisels and punches out of them. Of course the chisels will have to be hardened and tempered as is the general practice.

Old Ford magnets can be bought from most any garage at junk prices.

John Denbo, Illinois.

The city council of Rochester, N. Y., passed an ordinance in January, 1901, which required automobiles operated in that city to carry two lamps to be lighted within an hour after sundown and a gong or bell with which to warn pedestrians.



ALL HERE SAFE AND SOUND TODAY BECAUSE WE BELIEVE IN THAT AND PRACTICE IT

SHOEING REFRACTORY HORSES

To close the heels.—By shortening the bar. When the quarters are of the correct length.—Heat the bar and heels and, holding one heel on the face of the anvil, shoe perpendicular, strike on the elevated heel. This will shorten the bar, also narrowing and straightening the quarters.

(b) When the quarters are too short.—Place an inside edge of the bar on the point of the horn and strike on the part projecting over it. This will turn part of the bar into the heel.

(c) When the quarters are too long.—Hold the shoe upright, the center of the bar on the point of the anvil, and strike on the toe. This will push the bar toward the toe and shorten the shoe, bringing the heels closer together.

To lengthen the quarters without changing the bar.—Draw out the heels on the horn of the anvil as in the service shoe.

When one quarter is longer than the other, to bring the shoe back to its proper shape. Heat the shoe throughout, and, holding it upright with the point of the heel of the longer quarter on the face of the anvil, strike on the upper edge of the shoe directly over the point resting on the anvil.

Thinning the bar is often necessary in the case of a large frog. To accomplish this, the bar is welded at about one-half the required length and then drawn out on the face of the anvil, its lower surface being leveled with the ground surface of the shoe.

In the case of an exceptionally large frog, it is necessary to curve the bar below the ground surface to allow sufficient room and to prevent too much pressure. Toe and heel calks must be used with this shoe to insure a level ground surface.

To curve the bar.—Hold the shoe so that one end of the bar rests on the edge of the face and the other on the horn of the anvil and strike on the center of the upper surface.

The use of the tip for contracted heels leaves the foot in more nearly a state of nature than any other shoe, it is sufficient for ordinary work, and is easily applied. It should be thin, only thick enough to hold the nails, and not be flexible. The best tip can be made from an old shoe uniformly worn, the quarters being cut off just in front of the forth nail hole. Using the rasp across the toe, lower the toe

the desired amount as far back as the tip extends. The heels of the tip should be thinned. If after the tip is secured in place the walls back of the tip extended below its ground surface, they can easily be lowered level with the tip by use of rasp.

The tip may be made from bar steel. In such cases two nails on a side are sufficient, the nail being punched to correspond to the first and third nail holes of a service shoe.

Shoeing Refractory Horses—Most horses that can be classed as refractory in shoeing have been brought to this condition by improper handling when green and unaccustomed to the sights and sounds of a shoeing shop.

When a young horse has been

assigned to an organization, a common practice is to send him at once to the shop with instructions that he be shod by quiet means if possible, but by force if necessary.

No greater evil exists in the mounted service. It is as much our duty to gradually train a young horse to submit to shoeing as it is to patiently drill him to surrender to the bit and to work in the saddle or harness.

Summary methods not only ruin the horse's disposition, but subject the shoer to constant danger of injury.

Shoeing young horses.—The first step should be to teach the young animal that raising his feet will do him no harm, and this lesson should be given at the first grooming. The

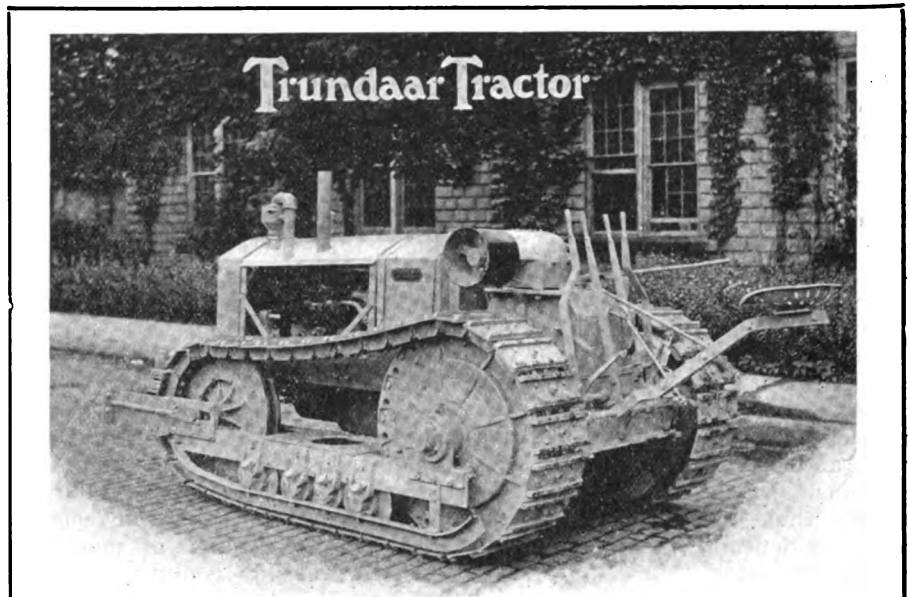

FACTS ABOUT THE TRUNDAAR

Engine—Buckeye-Waukesha four-cylinder tractor type. Bore and Stroke— $4\frac{1}{4} \times 6\frac{3}{4}$ in. Crankshaft—2 in diameter. Valves— $2\frac{1}{8}$ in-diameter. Ignition—High-tension magneto, with impulse starter. Governor—Waukesha patented type enclosed in engine. **Fuel System**—Buckeye-Deppe Integrator with fixed adjustment. Fuel tank—30 gallons capacity. Air cleaner—Highly efficient cleaner attached to Buckeye-Deppe Integrator. **Lubrication**—Constant level splash with surplus oil reservoir and circulating pump. **Cooling**—Force-feed pump and fan. Radiator especially designed for tractor service. **Engine rating**—52 brake horsepower. **Main clutch**—Multiple disc, running in oil. **Transmission**—Spur gear type. Unusually large margin of safety insured by use of $5\frac{1}{2}$ -in. face driving gear and 2-in. reduction gears; two speeds forward and reverse. **Drive clutches**—Multiple disc, running in oil, 28 in. in diameter. **Brakes**—Expanding type in drum on each drive clutch housing, 24 inches diameter.

Suspension—Double three-point suspension of power plant and tread units. **Protection from dust**—Every vital part runs in oil, and is impervious to dust. **Tread**—Trundaar Tread, built on log-chain principle; each link detachable; no lubrication required. **Tread wheels**—Rear 36 in. diameter; Front 30 in. diameter. **Width of tread**—15 in. **Length of tread on ground**—72 in. **Area on ground**—2160 square in. **Turning radius**—Within 12-ft. circle. **Horsepower rating**—20 draw-bar horsepower; 35 belt horsepower. **Steering**—Each tread is controlled by levers operating individual multiple disc clutches on the tread drivers, enabling the operator to steer by applying or disengaging the clutches. **Pulley attachment**—Mounted on transmission case directly over left tread driver. Pulley is 10-in. diameter by 8-in. face. Belt can be attached from either front or rear. **Width over all**—6 ft. 2 in. **Height**—4 ft. 10 in. **Length**—9 ft. 5 in. **Weight**—9200 lbs.

method of raising the fore foot and the hind foot, as explained in this manual, should be thoroughly understood by all enlisted men and be a part of the instruction of every recruit.

When the young horse surrenders his foot, lower it again quietly and pat him; later, use the brush on the soles of his feet; next tap the the soles lightly with the curry-comb; finally, take the shoer's position and go through the same steps. This complete instruction may be a matter of a day or of many days, depending upon the animal's disposition, but it should not be slighted nor hurried.

CARE AND REPAIR OF STARTING AND LIGHTING STORAGE BATTERIES

Repairing Batteries with Single Covers—A great many batteries now constructed with single moulded covers with a depression around the edge into which the sealing compound is poured.

In order to remove the elements from such cells it is only necessary to remove the connecting links as previously described and remove compound from the channel around the jar formed by the depression of the cover.

The element can then be removed with the cover attached to the posts.

Removal of the cover from the element can be effected according to the means by which it is attached and sealed to the posts.

The most usual methods are as follows:

No. 1.—The battery post is threaded and is provided with a flange, on which the cover rests, with a soft rubber sealing gasket between. A lead or hard rubber nut secures the cover to the post. To remove cover simply unscrew the nuts on positive and negative posts. In replacing a cover of this type the nut should be prevented from backing off by breaking the thread

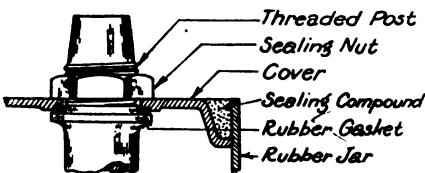

Fig. 1

in the post just above the nut, by means of a prick punch.

No. 2.—Sealing around posts is made by means of sealing compound. There are several designs of this kind but it is in any case

necessary to remove the compound or to soften it by heating before heating the cover can be removed.

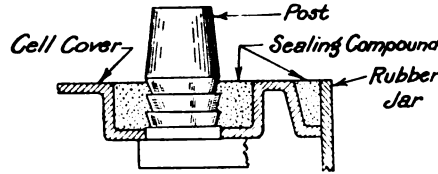

Fig. 2

No. 3.—A lead flange is screwed into the cover from the lower side. The inside of this flange fits the battery post and the outside tapers above the top of the cover so that when the cell connector is placed in position the three parts, namely—post, flange and connecting link—are burned together at the top.

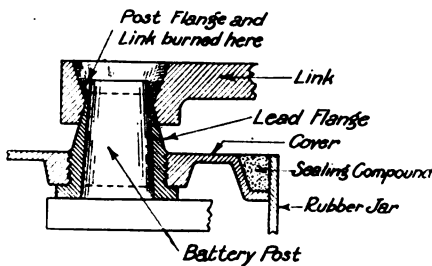

Fig. 3

When the connecting links are removed from both posts by drilling, the cover is free and can be lifted off.

In replacing the cover on such a battery great care must be taken that the edge of the lead flange is burned into the joint; a new flange being used if necessary.

Aside from the points described above, repairs to a single cover battery are to be handled as before described.

A BLACKSMITH THAT WEARS A WHITE COLLAR

There is a blacksmith shop in the little town of Craig, Colo., that is certainly a live place. John Lindstrom is the proprietor of the shop and is known as the blacksmith that wears a white collar. Lindstrom employes five men and is doing a big business—a business that is growing from month to month. The Craig blacksmith gives two things credit for his success—first he sees to it that his business gets publicity and the second is that it is run on the right kind of principles.

Lindstrom does not do any of the work at the forge in his shop. He oversees the business and keeps it running along in smooth order. He

has fitted himself up an office in one part of his building and that is where he spends most of his time. In his office he has his business down on paper where he can look at it from time to time and know just where he stands. He knows what it costs him from day to day for supplies; what it costs him for help and all other running expenses. He also knows what is coming in; who his best customers are, and he knows how much he is making from day to day. There is no guess work about his way of doing business and it is one of the reasons why he is succeeding. Mr. Lindstrom believes that too many blacksmiths spend too much time at hard labor in the work shop and do not know enough about their business and as a result they are not getting ahead. Mr. Lindstrom thinks it a far better policy to hire the shop work done and be in a position to look around and know what is going on in his own business—in other words, it is all right for the "boss" to wear a white collar during the work days of the week.

The Craig man also does a lot of advertising in his local paper featuring his business. He does not stop with that much publicity, however, but goes farther. He invites the editor of his local paper to his shop and when he comes around he has little stories that are of interest and which, of course, hinge on his business. Recently there appeared in the Craig paper a news item to the effect that Mr. Lindstrom had just installed a power blower with an easily regulated blast in his shop. The system is operated by an individual engine installed for the purpose and the blower is connected with all five of the forges. A large blower is attached to the wall near the first forge and a galvanized pipe runs along the wall with T connections leading to each forge, and each connection is equipped with a valve near its forge by which the strength of the blast is regulated.

It is not so easy to get such items in the papers in large cities, but it can be done in the smaller towns and a blacksmith should avail himself of the possibility as does the Craig, Colo., blacksmith. Keep your business in the limelight by advertising and in other ways making use of the local newspapers, and then after you get business coming your way as a result conduct your shop in a systematic way and success is pretty apt to come your way.

Queries—Answers—Notes



THIS department is the meeting place where you are free to ask for information, answer questions, discuss shop matters and business conditions and any other notes you feel would be of interest to a fellow mechanic. Make use of this Department as often as desired.

Can Anybody Help?—I am making a garden hoe out of spring steel, that is out of old auto and buggy spring steel. They make a fine hoe but I have not been able to get the proper temper to get them right. They want to be tempered so that a new file will cut and at the same time have a tough temper.

C. N. Anderson, Arkansas.

Another Interesting Letter From Australia—I would not be without the Auto & Tractor Shop for any price, especially the latest numbers; they can't be beat. I am not a blacksmith, I am in the motor engineering and bicycle building and motor cars are coming also now. I started as a blacksmith on my own in 1884 but spent eight years before this working for others. I have always been called upon to do anything from wagon repairing, shoeing, implement repairing to fixing up watches and clocks or anything that was brought to me. I carried on in this way until about 15 years ago, working from morning to night, until my eyesight went bad and was forbidden by the doctor to do any more blacksmithing. I had to obey and avoid the hot forge fire. I took a good long rest and then took up my present business.

I do not remember just when you sent me the first number of your paper, but I ordered it at once and have been a reader of it ever since and it has been as good as gold to me all the time.

I have learned a lot of valuable things from it. What I would like to know, as I am now in the motor business, is some information about the Dixie magneto, as these have only come on our markets recently and are somewhat new to me, but I see some articles in the last number that take up this subject.

Since I had to give up blacksmithing I have been building bicycles from the rough material, doing my own brazing, plating, enamelling, etc., until the finished product is ready for delivery. My work on motorcycles is mostly confined to repairing and rebuilding old models of every make under the sun. Besides this I am called upon to repair or get going balky farm engines, of which there is one or two on every farm hereabouts. These engines, are of all makes the world produces; oil or petrol and from one to ten h. p. We have only one motor car here at present and it is a Ford. I long ago knew them from our paper and a good many others too. Cars are coming greatly into fashion here and if was not for the scarcity and high price of petrol we would have a full dozen or more of them here by now. There are guns, sewing machines, separators, buckets, dishes, in fact every thing possible and impossible to repair, and in fact anything that an "out-back" mechanic is called on to repair. Now, surely you will

think I am a jack of all trades and master of none" part of it won't hold. ago I have learned them all so the "master of none" part of it won't hold.

I have a six foot boring, turning and screw cutting lathe, dynamo, grinder, polisher, drill press and numberless other tools and machines. I drive these machines from my motorcycle which has a four h. p. engine, by disconnecting its drive from the rear wheel and belt it up to the machine that I want to use, the cycle being fastened to the floor in a simple manner, so when I want it for

to be conducted in all parts of the United States and Canada. This course is a complete, practical and thorough course in farm tractors and power machinery in general, and is extended to all farmers and operators absolutely free.

The course lasts one week in a place, and the work is divided into three branches: 1—Lecture and Introduction, 2—Repair and Shop work, 3—Tractor Operation and Work on Tractors. The course will take up the following very important subjects.

The Motor; Its principle; operation and adjustments; general motor troubles; loss of power; How to grind and reset valves; fitting pistons and rings; adjusting bearings; timing of valves and ignition with motor; lubrication of motors.

Ignition System: The different types and their principle; how to detect and remedy ignition trouble; adjustment and care of ignition system.

Fuels and Carburetion: fuels, their comparison and use; carburetor trouble; adjustment of carburetor; kerosene and its use.

Lubrication and Lubricants: Oils and greases and their proper use; oiling systems, adjustment and care.

Cooling system: Cooling system explained, its proper use and care.

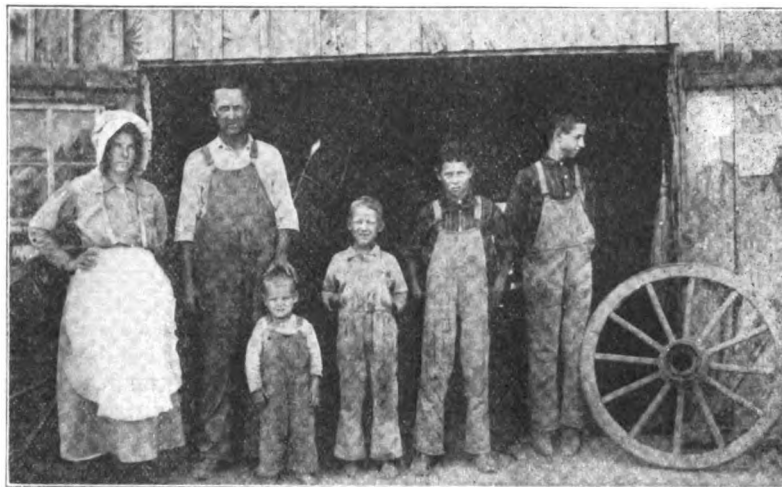

MR. R. N. BRYANT AND HIS HELPERS KEEP THINGS MOVING AROUND THIS MISSOURI SHOP

travel it only takes five minutes to have it ready for that purpose and be on my way. I only use it for running the machine when there is at least several hours work to be done at a time, otherwise they are operated by a foot treadle.

We are doing funny things here sometimes. I have seen a motorcycle cut chaff and another motorcycle engine here in the neighborhood has been used for cleaning wheat, cutting chaff and pumped all the water on the farm for several years and is still on the job. This engine was fitted with a water jacket, as we know pretty well that a motor cycle engine needs travel to keep it cool, but if used as a stationary engine we know how to keep it cool. You may have a good laugh at the way we are doing things here, but a motor cycle is a handy thing and can be ridden when wanted and back too.

F. H. Gierke, South Australia.

Free Tractor School—To help farmers power machinery more successfully, the J. I. Case T. M. Co., of Racine, Wis., announce its seventh annual service schools

Tractor Chassis: Trucks and frame; transmission and gears; adjustment, overhauling and general care of tractor.

Tractor Operation: Starting Motor and handling tractor; general operative subjects.

Tractor Work: Use of tractors for various operations; traction work-belt work; proper use of tractor.

Implements: Hitching of plows and farm implements; draft of various implements; care and operation of farm implements.

The following schedule for the Western States has already been arranged, and is as follows:

Billings, Montana, 2203-2217 Montana Ave., November 19th to 23rd.

Spokane, Washington, Monroe St. and Boone Ave., Nov. 26 to 30th.

Portland, Oregon, 322 E. Clay St., December 3rd to 7th.

San Francisco, 16th and Kansas Sts., Dec. 10th to 14th.

Salt Lake City, Utah, 238 West Temple St., Dec. 17th to 21st.

"Toe in" of Auto Wheels—Can you give me any information on the width between the front and rear of wheels of an auto so the tire will wear right?

T. W. Kitto, Illinois.

In Reply the toe in for Fords is $\frac{1}{4}$ inch, that of the Dodge is 3-8 inch measured on the felloes of the wheels level with the hubs. The distance between the front wheels should be from $\frac{1}{4}$ to $\frac{3}{8}$ inch less than at the rear of the wheel. The measurements should be made from center to center of the tires, about half way up the wheel and in line with the hubs.

The above measurements are correct for comparatively new cars and should be increased somewhat as the steering knuckle becomes loosened through wear.

The amount of "toe in" can be adjusted by adjusting the length of the steering knuckle tie rod, from one steering knuckle to the other. This adjustment should be made with the wheels on the ground. The idea in "toe in" is necessary because when runing, the wheels have a tendency to "toe out" when the car is in motion.

The front and rear wheels should track, if not the fault can be detected by the front and rear wheels leaving two distinct tracks.

J. S. H., New York.

Going Into Shipyard Work—I am about to quite a business that I and my father before me have spent our lifetime at. We have always had good health but not much wealth and I am going into the shipyards.

I haven't so much fault to find with the trade only that our shoeing is about four times heavier than it used to be, not that we don't get more for it. What the blacksmiths in Burlington county needs is a union and anyone will tell you that this old boy had always been ahead of them on prices.

This town has a population of about 1,400 and is in the farm and berry country of Jersey. I am past the draft age for which I am sorry as I would like to get me a few Fritzi's, however, some of my boys who are within the draft limits have promised to get a few of them for the "old man."

P. W. J., New Jersey.

For Welding Steel—Please give me a formula for welding compound.

J. C. Rix, Missouri.

What is recommended as a satisfactory welding flux for steel is composed of one part sal-ammoniac and 10 parts of borax by weight, pounding together and fused until clear, when it is poured out and, after cooling, reduced to a powder.

Not Live Thing On Ranch—Gas Does All Work—Tractors and motor trucks have displaced forty horses and their drivers on the 2500-acre ranch of F. B. Nims, of California.

"I haven't a live thing on the place," says Nims. "I used to have forty horses and all kinds of trouble keeping drivers for them. Finally I decided to try gas engine power. I bought a 75-horsepower Holt 'Caterpillar' Tractor, an Avery motor cultivator and 3-ton Ford truck, and now my troubles are over. I never want to see a horse again."

The F. B. Nims ranch is of 2500 acres, irrigated, in the Sacramento valley, protected from inundation by dykes. Beans and barley are grown alternately on 500-acre tracts. In the early spring, water is let on to the land from the river until it is entirely covered. Immense gas engine-driven pumps then pump it out until the

level has been reduced to a foot or so below the surface of the soil.

In a few days the surface has dried sufficiently for plowing and the big "75" Holt goes to work and keeps at it 22 hours a day until the plowing is all done. Then it pulls the seeders for the barley, while the beans are planted by the motor cultivator. Water again is let into the proper level. After the beans are up, they are cultivated with the motor cultivator.

At harvest time the tractor pulls a 26-foot cut harvester and bean harvester, the latter carrying a 44-horsepower engine to actuate its mechanism. The harvesters thresh and sack at the same time and drop the sacks in bunches of ten. These are picked up by motor trucks and carried to market. The whole cycle of operation is performed by gasoline power.

(Incidentally, Mr. Nims is interested in a bean cannery at Stockton and goes on



THIS COLLECTION OF SOLID CALK, HAND TURNED SHOES EXPRESSES THE FINISHED CRAFTSMANSHIP OF JOHN Y. OSBORNE, OF NEW HAMPSHIRE

the principle that "Nims' Beans" must be right, consequently he grows them himself.—Editor.)

To Tell Steel from Iron—In most cases steel that scales off white and silvery is high carbon. Some steel scales but little and shows colors on the hardened part. This denotes poor stock. Good steel will usually show a thin, small scale rising on the surface when heating to harden, just before it gets to hardening point. When steel shows a thick, heavy scale it is usually poor. To tell the carbon content, heat the stock until it scintillates or falls apart. If it does this as soon as you have a white heat, it is high carbon. If it can be heated so that the flux starts, it is low carbon. To test quality, draw down one end like a chisel and pack well at a low heat. Then harden and before the temper runs down, break the section noting the color. If the surface inside is white and sparkling it indicates poor steel; if it has a fine grain and bluish tinge it can be used for good tools.

Hardening Plow Shares—I am looking for a receipt for hardening plows. The best one I ever saw was in your magazine in 1915. I have lost the paper and I just wondered if you had something that is good for hardening plows.

J. B. Windle, Iowa.

In hardening plow shares, if the share is of soft center steel, proceed as follows: First, heat the whole point to a very

low red heat; then turn the share face down with the heel over the fire, and the point in such a position that it is about two inches higher than the heel. This will draw the fire from the heel along toward the point, and the whole length of the share will be heated almost in one heat. Be sure to get an even heat or it will warp or crack if it is unevenly heated. When the share has a moderate red heat, take it out and you will notice that it is sprung up along the edge. The share is now sprung down. This is the general rule but there may be exceptions.

In either case set it right—though you cannot with any success set it by a table or leveling block as this will cool off the square a little. So use your eye and set the share with the hammer over the anvil. This done, hold the share over the fire until it is at a low red heat—like before—and plunge it into a tub of hardening compound. This can be purchased—or, sprinkle the share with prussiate of potash and plunge into a barrel of salt water.

The share generally warps more out of shape in heating, but will also warp in cooling if the heat has been too high. Poor scouring may come from the lay and mould board being too soft and thus not taking a good polish or it may be full of rough hammer marks.—From APRIL 1915 Number.

Still Gets It—"I have received the August number and find it more interesting than ever. I am getting along very good with the work here, considering the material, methods and equipment we have to work with. At this writing I am in the best of health and am living in an old house. Will try and write an article for your magazine later."

Corporal Ernest C. Schnoor,
A. E. F.

In The Front Lines—"My paper arrives here O. K. and is of great interest to all of us in the trade. It is passed around until it is worn out."

Corp. Farrier James Wallace,
Canadian Expeditionary Forces.

Prices In Alabama—We don't see how we could get along without the Auto & Tractor Shop and for what interest they may have to others we are giving you some of our prices.

Shoeing \$1.40 up to No. 3, \$1.50 for No. 4, \$1.60 for No. 5, \$1.75 for No. 6. Setting buggy tires \$3; putting on new buggy tires \$8; setting wagon tires \$2 to \$4; putting in axle \$4 to \$8; spokes 25 cents; felloes 40 cents; and up (joint felloes); plow lays \$1.50 and up; plow sharpening 10 cents to 30 cents; cross bar \$1.25; welding shaft irons 75 cents.

A. H. Pence & Son, Alabama.

Wants To Know About Power Hammers—I would like to get some of your readers' opinions on power hammers; the advantages and disadvantages of the two different types—the helve hammer and the vertical—for use in general smith shop work.

Fred Colbridge, England.

Charcoal for Grinding.

It is not very generally known that powdered charcoal mixed with kerosene oil makes a very satisfactory valve grinding compound, in the absence of the regular product. The mixture is applied in the regular way and grinding carried out just as with ordinary grinding compounds. The charcoal produces a very fine surface and, unless the valves are in unusually bad condition, requires little more time than the regular compounds.

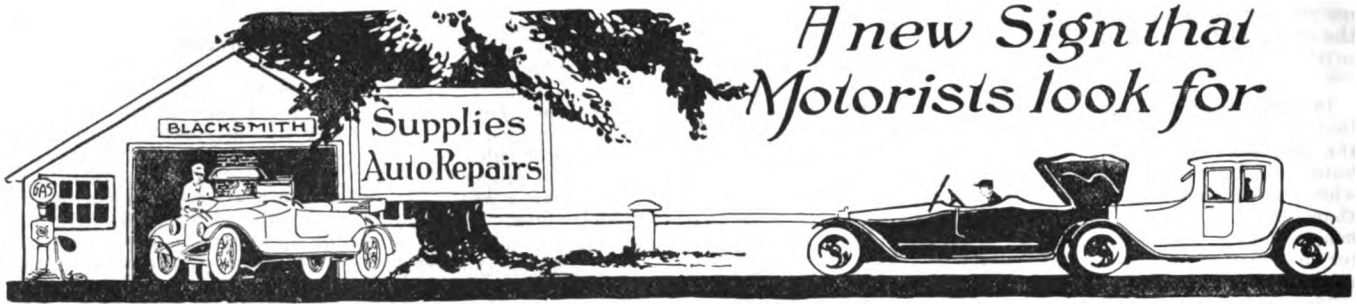

THE MODERN MOTOR CAR

The 1919 edition of the Modern Motor Car by H. P. Manly, which covers in a thorough and comprehensive manner the care, repair and upkeep of practically every type of automobile is just off the press and can be obtained through our book department at \$2 per copy.

The new edition has 536 pages, with 225 illustrations, and makes a valuable reference book for the car owner, dealer, garage man or mechanic, as the subjects of construction, care and adjustment of motor car parts, together with shop and roadside methods of trouble location and repair are treated in a simplified style, while information is also given on how to buy, make and use materials and supplies.

DEFECTOMETER

A new and useful device for those engaged in magneto repair work, the only magneto testing outfit on the market today. With it the electrical repair man can trace all magneto troubles in a jiffy.



This inexpensive outfit was designed by an authority on magneto work and is thoroughly practical and reliable at all times, it is substantially constructed and will last indefinitely.

The defectometer is so simple compact and quick and dependable in operation that it makes work in connection with it a pleasure. It tells you unmistakably

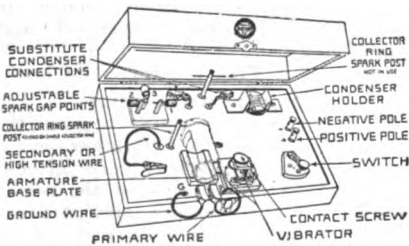

where the trouble is. There are no intricate parts to get out of order.

This apparatus is designed and manufactured by Paul G. Niehoff & Co. Inc., Chicago, Illinois, magneto authorities.

In addition to manufacturing the defectometer the Niehoff company is prepared to rewind any make of magneto armature at short notice and at reasonable cost. They also manufacture and sell make as well as all sorts of platinum, a superior line of condensers, slip rings and other parts for magnetoes of any tungsten and other metallic contact points for automobile and other electrical instruments.

ELECTRICAL SERVICE PARTS

The Automobile Ignition Coil situation has, in the past, been a serious problem for jobbers, dealers, and service stations,

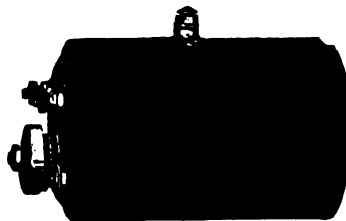

owing to the multiplicity of types on the market. Many jobbers and dealers have had to pass up the coil field almost entirely because of the large and varied stock of coils that would be necessary to take care of all requirements.

The Jefferson Electric Manufacturing Company of Chicago have recently placed on the market a line of Battery Replacement Coils and Fittings which are sufficiently flexible to displace any type of coil on battery-equipped cars. The extreme flexibility of Jefferson Coils is obtained from several features, which include the fittings, adjustable caps, terminals, and mounting arrangements.

With a small stock of Jefferson Coils, any service station, garage, or repair shop will be prepared for any emergency. Heretofore, it has been necessary to lay up a car for perhaps several days while a new coil was being obtained. Now, however, any car can be placed in service within a few minutes. It is only necessary to remove the old coil and connect the Jefferson.

Starting conditions require a coil that will produce a hot, intense spark when the battery is at the lowest ebb. Jefferson Coils are guaranteed to take care of this extreme condition.

To aid jobbers, dealers, service stations, and garage men, the Jefferson Electric Manufacturing Company have compiled a folder containing complete and authentic data covering all standard battery ignition systems. This folder lists all makes of coils from 1912 to the present date, and gives the year, model, type of ignition, and style of Jefferson Coil to be used for replacement. This folder will be sent free of charge to any dealer, garage, service

station, or jobber. Request should be addressed to the Jefferson Electric Manufacturing Company, Congress and Green Streets, Chicago., Dep't. B.

REBUILDING AND RETREADING TIRES

Never in the history of the tire business has the demand for rebuilt tires been as great as it is today. Urgent requests are made on the tire users to conserve their tires and eliminate the waste that in the past has run into enormous figures. It is a known fact that a large percentage of carcasses outwear the original tread and if re-treaded are good for many miles of service, in fact are just as good as a new tire. Owing to government regulation, eliminating a large number of the tire sizes now in use will create a demand for rebuilt tires that cannot be obtained from the manufacturer. Are you in a position to serve your customers and supply them or are you letting the other fellow serve him?

With the Zwebell retreader and tire rebuilding machine you are in a position to supply this demand, doing the work and giving your customers the service they want, for which they are sending out of town. You can also rebuild for your own stock these discontinued sizes for which

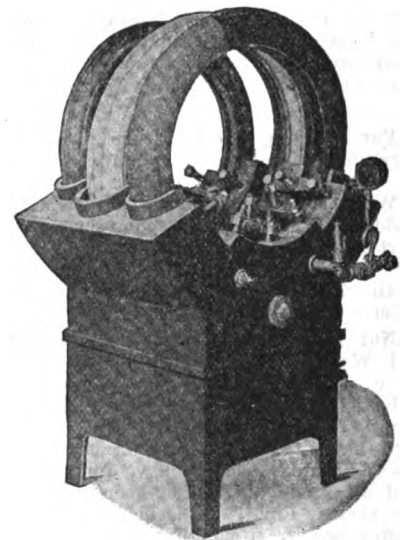

you will find a ready market at a good margin of profit. You will have no idle hours in your shop or loss of profit in the winter months. You owe it to your customer, your business and yourself to so equip your shop that you can supply the demand made on you. Figures show that the Zwebell tire rebuilding machine with its wide range of usefulness if worked to capacity will pay for itself in thirty days.

AMERICAN BLACKSMITH AUTO & TRACTOR SHOP

VOLUME 18

DECEMBER, 1918

NUMBER 3

BUFFALO, N. Y., U. S. A.

Established 1901. Published Monthly at the Sidway Building, Buffalo, N. Y., by the

AMERICAN BLACKSMITH COMPANY

Incorporated under New York State Laws.

WILLIAM F. WENDT, *President.*

WALTER O. BERNHARDT, *Editor.*

SUBSCRIPTION PRICE:

For \$1.00 per year, payable in advance, The American Blacksmith, Auto & Tractor Shop will be sent, postage prepaid to any postoffice in the United States. To Canada, \$1.25; to other countries, 6 shillings. Reduced rates to clubs of five or more on application.

Remittances may be made by money order, express order or checks payable to the American Blacksmith Company. We will also accept uncanceled postage stamps or currency, but for safety these should be sent by registered mail.

Subscribers should notify us at once of non-receipt of paper or change of address. In latter case, give both old and new address.

Correspondence on all smithing subjects solicited. Always give name and address, which will be omitted in publishing, if desired. Address all communications to the

"AMERICAN BLACKSMITH COMPANY"
BUFFALO, N. Y.

"Copyright W. F. Wendt Publishing Company, 1918."

Cable Address: "Blacksmith, Buffalo"

CONTENTS—DECEMBER, 1918

| | |
|--|----|
| Four Years of Smithing Under Fire.. | 55 |
| New System of Street Corner Signals | 57 |
| Hanging Garage and Shop Doors..... | 58 |
| Anthony Zeman; His Shop..... | 59 |
| Overseas with Our Boys..... | 60 |
| Hardness and Wear..... | 62 |
| Weights of Square Steel up to 2".... | 63 |
| Tractor and Horses | 63 |
| Stitches in Time..... | 65 |
| Cleaning Jewelry, etc..... | 65 |
| Bicycle Tire and Anti Leak..... | 65 |
| Etching on Copper..... | 65 |
| Making Tractor Starting Easy..... | 68 |
| Future of the Auto Industry in Britain | 69 |
| Christmas Tree Holder..... | 70 |
| How I Built a Power Hammer..... | 71 |
| Repairing Automobile Storage Bat- teries | 74 |
| Farmers Becoming Motorized | 75 |
| Legal Considerations in Sale of Used Cars | 76 |

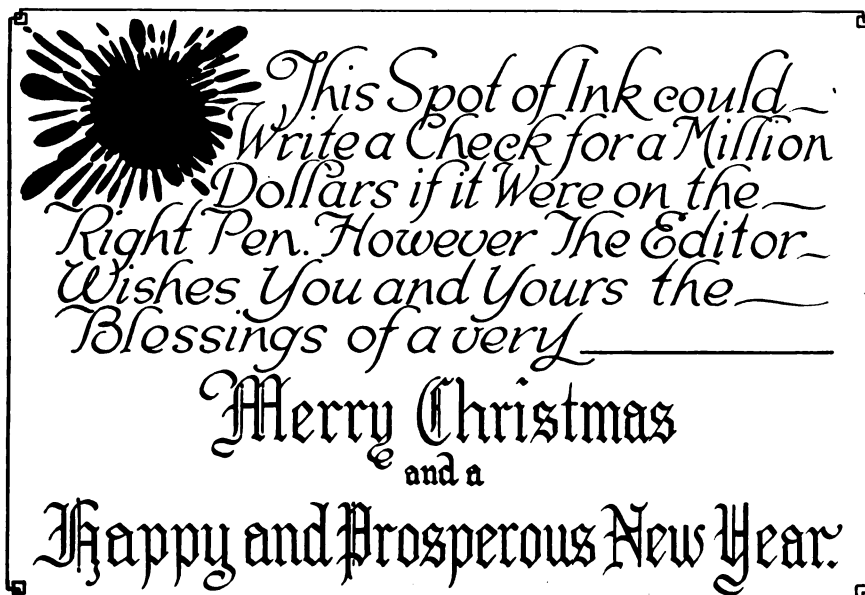

THE NEW YEAR AND GOOD INTENTIONS

The old saying that "hell is paved with good intentions" may possibly be true. If it is, then we may be sure that Tophet has some mighty fine pavements. However, be as it may, the New Year is the generally accepted time for us to swear off cussin' and smoking and a lot of other things and resolve to do better in the future, and while we're at it we're going to suggest a few good resolutions and also make some of our own and here they are:

Put your business on a business basis and Trust in God but Charge Cash.

Investigate the possibilities of Auto & Tractor work.

Go out into the highways and compel business to come in.

Help the other fellow by writing us about business conditions, helpful methods, etc.

Renew your subscription.

The easiest job on earth is to pass out advice and suggestions to the other fellow and after having been so generous with our advice in this direction we are going to make a resolution and our readers are called upon to bear witness that:

While the American Blacksmith, Auto & Tractor Shop has been a mighty good paper and an ever present help in time of trouble in the past, and in general a good thing to have about the shop, the year 1919 will see it a better publication in every particular than ever before—So Help us Pete.

DON'T GIVE MONEY TO AGENTS

The American Blacksmith, Auto & Tractor Shop DOES NOT employ subscription agents. Any person representing himself as such is an impostor and should be so dealt with. Notify us immediately if anyone claiming to represent this journal calls upon you.



American Cavalrymen buying stores from French peasant.



Sardinian soldier in the saddle.



French Dragoon from Vincennes.



HAVING read a very interesting account of conditions "out here" in the Auto & Tractor Shop, I thought that some of my experiences in military workshops would be of interest.

I enlisted as a smith in the Mechanical Transport Section of the Army Service Corps on August 7, 1914, was posted to a company mobilizing for active service and landed in France ten days later.

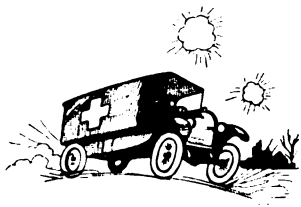

As you can imagine my first taste of active service was rather exciting, as our company managed to get well up country and get mixed up in the retreat from Mons. For the first three months we had very little workshop practice, for two or three different reasons, the chief of which was the complete loss of our workshops, kits, tools, etc., and also to being continually on the move. Consequently what work we did was done at wayside French smithies until we got our workshop replaced. We thanked our lucky stars that the cars we were supplied with were in tip-top condition, these cars being mostly commandeered from commercial firms in England. We were also grateful that the roads were in excellent condition, not having had time to get torn up as they later became under the excessively heavy military traffic. I believe that in this retreat that we had to abandon 18 out of 140 lorries. If it was found impossible to bring a disabled car along we usually stripped it completely, removing the magneto and

other fittings and smashed the cylinders with a sledge hammer.

After about three months of careering around the country we gradually settled down to work and established a regular work shop routine. Previous to this any job that came along, the first mechanic our staff sergeant could find clicked for it. From this onward, morning parades were started and mechanics detailed to different jobs.

Regarding my own work; it was not too hard (spring trouble not then having developed to any extent, but of this more later) being mostly ordinary repair jobs such as lamp brackets, wing stays, bent axles, tailboard irons and such other broken parts that could be repaired or replaced by me. Occasionally a new drop arm or starting handle had to be forged from what stray material we could find. Also a spring would break now and then and having no spare parts or no spring steel to replace the leaves with, recourse was made temporarily by "plating". Of course such repairs only lasted a few weeks but they served the purpose for the time being until we began to get spare springs and and spring steel to make a more permanent job.

We now began the spring of '15 with the problem confronting us of making large "U" superstructures for supporting the sheets or tarpaulin covers for the lorries. These were roughly six feet six inches, by six feet, three inches, the two end pieces being of 1½ inch angle iron and the center one made of flat stock. Of these we had to fit 120 lorries. Nowadays, the lorries are delivered out here with superstructures and everything else complete.

One trouble we encounter out here is to get accustomed to welding mild steel as there is no iron

stock issued to the Mechanical Transport and of course this is only a question of getting used to conditions.

The real problem that confronts the smith here today is spring trouble and right here let me say that I have repaired hundreds of them. As regards the old controversy that has been discussed in the Journal from time to time about welding springs, I will give my opinion for what it is worth. I have springs running now with welded leaves but do not advise it, and repairs of this sort are not encouraged in the army, there being no issue of special welding flux. One reason why welding is not advisable comes from the fact that most leaves are too wide and thin to give one a fair chance or too heavy to handle to give them heat treatment after welding (I do not mean heavy ones cannot be welded, my meaning is that they take entirely too long to do—scarfing and welding and then heat treatment to remove internal



strain, the latter is more important than the actual welding. This time would be much more usefully applied in making a new leaf.

The leaves I have welded have been about 2x5-16 and were broken fairly close to the end and thereby giving a fair chance to heat treat them in the fire after welding to remove the strains that form about four inches from the weld, which is one thing to study in spring

welding. I have seen heavy leaves which have been welded in the center (the weld itself having been a good one) break about four inches from the weld, just where the strain is set up through the two extremes meeting; the heat from



the weld and the cold from the cold part of the leaves. My method is to well upset and scarf the ends and punch a hole in each to take a 5x16 rivet, get the ends and the rivet fairly warm and then rivet the two ends together. Then I get a pretty white heat on them, using a little crushed borax and sal ammoniac as a flux and then getting the helper to give me a blow on them. I have been fairly successful with such repairs but when all is said and done one must come to the conclusion that it is against the nature of spring steel to expect it to stand what it has to after having been brought to a welding heat; one can make a far better job if he can get the stuff to make a new leaf. With that I will drop the welding question.

Now, about tempering a spring leaf. I think it will be admitted that 99 out of 100 smiths can make a good spring leaf and the hundredth one will make a fair job of it, but how many of the whole hundred will make a good job of tempering that leaf?

I will endeavor to explain how to get a good tempered spring leaf and one that will stand up to its work.

The one thing to study in tempering is to stop uneven strains. You get the same thing at times in a chisel in a small way, which shows a crack that may have been caused when the tool was quenched, through the end of the chisel being dead hard and the heat traveling down from the thicker part of the chisel causing an unequal strain between two points, one being the cold end of the chisel and fully contracted and the other being where the heat is in the thicker part of the chisel and which is expanded. Thus, an unequal strain is caused.

To temper the spring leaf, if rather long, build a stock fire up, put the leaf in the fire and start heating from one end first, let the

end stop until you see it just turning red and then push the leaf further into the fire, thus carrying on until the leaf is evenly heated all through. Keep passing back and forth through the fire until it comes to a bright red (this with ordinary spring steel. Some you will not have to get quite to hot and even then you may have to put oil on top of the water to pass the leaf through lest it crack). When you see the leaf is bright red and fairly even throughout the leaf you may be sure you have avoided setting up uneven strains. Then holding the leaf by the center or with two pairs of tongs, if it is long, dip the leaf into a brine bath, pull out after it has been dipped for a second or so, turn the leaf over, grip the other side and dip again. Repeat dipping a few times until the leaf finishes "sizzling".

Now, think this over between the dips you have been turning the leaf around. The idea is not so much to prevent the leaf from warping as it is to give time for the leaf to contract evenly. It is giving time for the coldness imparted by the water to spread itself evenly throughout the leaf, thereby avoiding setting up such a strain again.

By giving it time to contract that way, when you have finished you have a leaf in a dead state but not unevenly contracted. The leaf will be just over warm now. Put it in the fire, turn on the blast, starting from the end again in the same manner as mentioned so the heat will steadily travel along the leaf, pass it through the fire fairly quick, turn off the blast and pass through the fire without the blast. The idea is to let the heat gradually spread through the leaf, thereby reversing the process it underwent in quenching. Keep passing through the fire steadily until little red flecks will show when a dry ash stick is rubbed all along the leaf. Then set to what you require and allow to cool.

With practice you will find that this is one of the best tempers procurable outside of a spring factory. The one thing to avoid during the whole process is getting unequal strain anywhere along the whole leaf. I have tempered many springs under active service conditions and they usually stand top-hole, but springs are a real study and one can get much interest in studying them. One never wonders why they break when he sees some of the roads out here—he wonders how they ever stand it at all.

In spring work, one problem arises—a big majority of springs have to be straightened or reinforced. Well and good, that is done, what happens? The shock that the spring does not take is distributed elsewhere causing at times such troubles as cracked chassis, bodies working loose, bent axles, rubber water connections tearing through, besides probably undue stress and strain on such vital parts as the engine and gear box.

In my experience out here one particular make of lorry has never broken a rear spring, no, they are very strong but what else has occurred fairly often — cracked frames—which is a far worse trouble. This, however, is a problem for the designers of the lorries. The same thing occurs in light cars also. Spring trouble to any great extent really started from the first Somme offensive in July, 1916 and onward. The winter of '16 and '17 being particularly bad in this respect, chiefly from the lack of sufficient spare springs to replace breakages and lack of spring steel for spring purposes. It was no uncommon thing that winter for whole lorry parks to be out of commission with spring trouble combined with radiator trouble from the severe frosts. Around about that time springs which had lasted since the war began broke, until by the end of the



winter nearly every one of our lorries had had every spring changed. It was a case of hard work for us smiths then. Since then we have been well supplied with springs and steel and this has enabled us to cope with the work better. One great difficulty is the large number of different makes of lorries, each one having different types of springs and no two makes having interchangeable springs, not only different sizes of springs but different ways of fitting them, some having bolts through the spring, others with slots through and riveted to a box, others with beaded centers and so on down the list. This all helps to make our work more difficult. This also applies to ambulances, light cars, etc.

I was much interested in Serg't.

Northwood's recent articles. His idea of repairing Sunbeam crown gears is good. I had not seen that difficulty overcome yet, the lamp bracket repair we did much after the same fashion, screwing the end in and brazing same. The first aid outfit is another excellent idea. We had to make a permanent crane fitted to a heavy lorry for first aid lorry for heavy work.

This we did by utilizing two derelict chassis frames, bracing them together and erecting them on a lorry. These used to carry in heavy lorries swung on them, the back wheels of the patient being on the ground of course.

Chassis plating we have at times as described by Mr. Northwood's article. Bent axles are also a



source of much trouble and we have had to reinforce many of the built-up type of girder axles.

A smith out here can rely on having plenty of good hard work and also some jobs that will make him strain his brain more than a little bit. A good, heavy drop arm is not a bad piece of work with a small fan forge, a 140 pound anvil and tools to suit, especially when you have a lump of three inch round mild steel to bump it out of that is almost as large as your anvil.

Still, I suppose we get along with it and take our satisfaction in the fact that we are beating the Hun. I get the Auto & Tractor Shop sent out to me here and am very much interested in it when it comes.

SHOP WRINKLES

Grease a hard running saw with kerosene. This oil will not stain the wood.

A piece of sandpaper or emery cloth is an excellent thing to keep near a gasoline or kerosene can to remove the cap when it is stuck.

Glue that is forced out of a mortise point and allowed to become dry and hard, can be easily removed with a sharp chisel dipped in oil.

The blacksmith can get plenty of muscular exercise even if all unnecessary movements are cut out, and if he follows up the pruning out faithfully, he may do more work without tiring himself so much.

A NEW SYSTEM OF STREET CORNER SIGNALS

Albert Marple

Some of the leading automobile owners in the western part of this country are now asking the question, "Why cannot we have a practical system of arm signals that is worthy of universal adoption, so that the number of traffic accidents in our cities may be reduced? This question comes almost as a cry of despair in view of the fact of the large number of accidents that are occurring daily at the street intersections in western municipalities, which, of recent date, have increased in number at an alarming rate.

A very large percentage of these accidents result from a misunderstanding of traffic signals or from the neglect of motorists to give any signal at all. Supposing, for instances, that two machines, one directly behind the other, are approaching a corner. The driver of the car in the rear has absolutely no way of knowing what the intentions of the first driver are with regard to his actions upon reaching

the fellow in front will begin suit against the fellow in the rear for bumping into the rear of his car.

At the present time it is the general practice of motorists to thrust the hand out at the side of the car in the direction toward which he intends turning. The argument against this system is that it is indeed difficult for the driver of a car having a left hand drive to extend his hand out sufficiently far over the right hand side of the machine for the man in the machine that is following to see it.

A system of arm traffic signals has, however, been brought forward by a prominent motorist, which promises to do away with a big percentage of accidents at street intersections. And the practical point about this set of signals is that all of them may be given by the driver of the machine while he is sitting directly behind the wheel of his car, and with very little effort. This system consists of three positions of the left arm, each position carrying its own particular message. The set of signals now being urged is as follows: Left arm straight out, as shown means turn to left; arm in elevated or upright position, turn to right; arm pointing downward, means the driver intends to slow down.

DO YOU DO BUSINESS THIS WAY?

Many a man prices his goods blindly, not knowing for a certainty the exact cost of the goods plus transportation charges, overhead and General Expense. In General Expense should be included bad debts, loss through adjustments of sales which have been unsatisfactory, and all other "outs" which are not regularly accounted for elsewhere. It should be easy to find out what percentage each dollar of business should bear of this General Expense. Thus, if an article costs \$5, the transportation charge is 12c, the overhead \$1.25, the General Expense tax 15c, and the interest on the money invested (counting a three times a year turnover) 10c, the total cost will be \$6.62, and anything in advance of this, profit. Many a man thinks he is making a profit though when he is not. A business which does not make a reasonable net profit cannot long serve its customers well nor maintain its integrity, even if it manages to maintain a struggling existence.

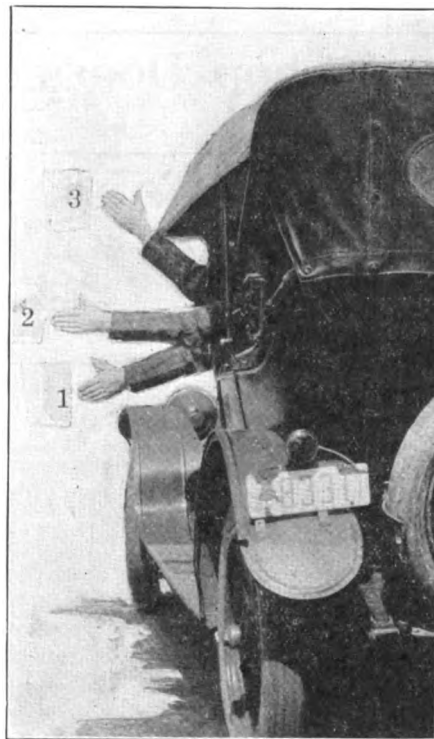

"SAFETY FIRST"

- 1—Slow Down or Stop
- 2—Turn to Left
- 3—Turn to Right.

the street intersection, and for this reason he follows blindly, "trusting to luck" that the fellow in front will not slow up for a turn so abruptly as to cause a collision between the two machines. If this should happen the chances are that

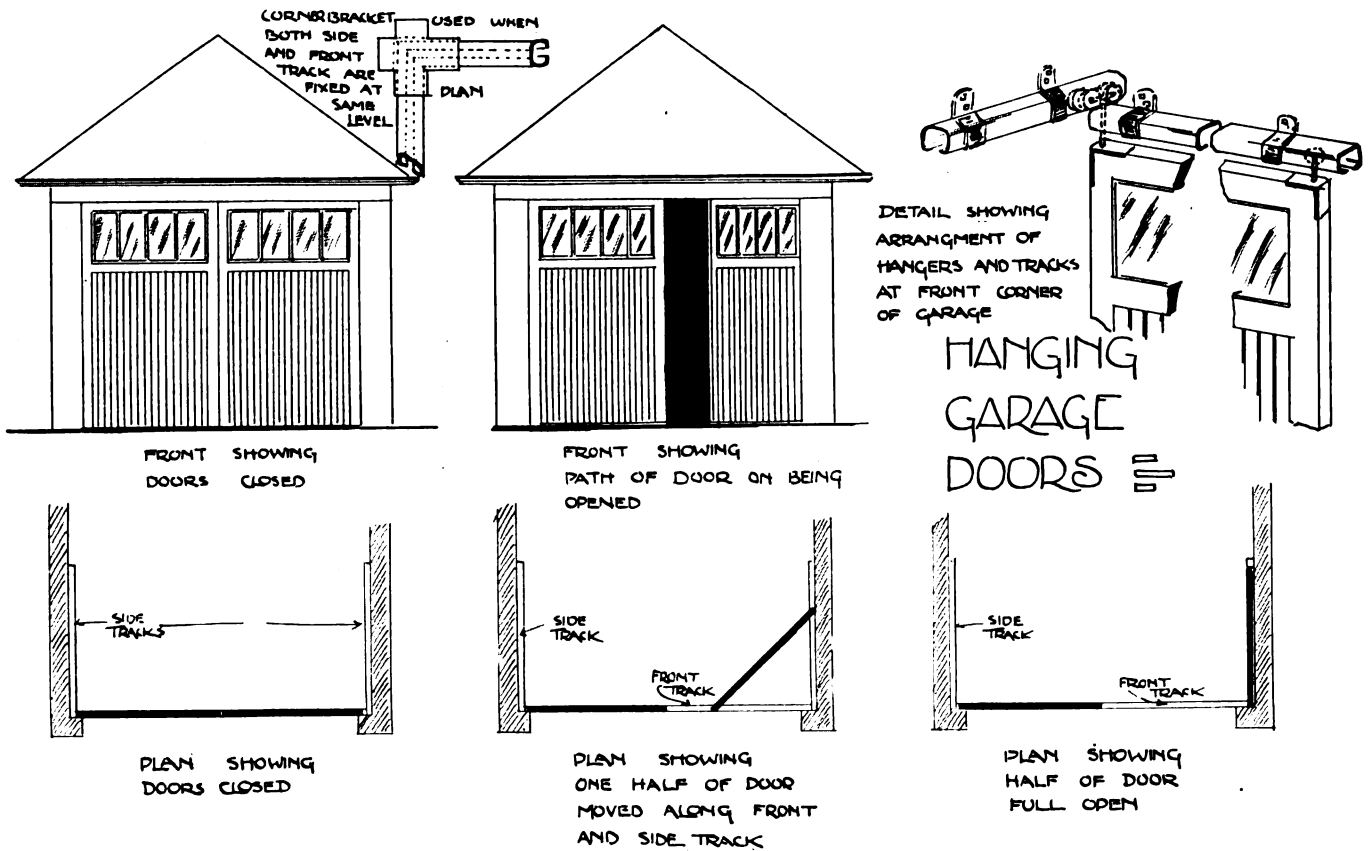

Hanging Garage and Shop Doors

JOHN Y. DUNLOP

An important adjunct to the modern home is the garage that shelters the family car, now counted the greatest convenience of time, aside from modern plumbing and other of our present day means of enjoying life.

The size of the garage depends of course, on the number and size of the cars but if there is only one and it of the smallest make, the garage should have a convenient entrance.

At the present time we have all sorts of entrance doors, both of the hinged and sliding variety but I am sure there is nothing so complete in its movement than the corner door, so called, from the fact that the door on opening slides round the corner into place at right angles to its closed position.

In this way the door occupies practically no room and what is of more importance than easy opening, it is possible to maneuver the car in a space free from obstructions. This style of hanger has two particularly valuable features to commend it over other methods of hanging garage doors. The first

of these is that the open doors are not liable to blow shut on the car as it is being driven in or out of the garage. The second is, that you don't have to shovel a half acre of snow to get the doors open in the winter time. There are other equally obvious advantages of this arrangement that makes this highly desirable.

The accompanying sketches show the door in various positions as well as the fittings required.

The hangers are first fitted on to the top corners of the doors, the meeting styles having a hanger with two wheels and a short rod or pendant, as shown. The outer styles having a wheel with four wheels and a long rod which is required, since the side track rests on the top of the front one. The corner plates of the meeting style hangers must be checked in flush on the closing edge.

In fixing the tracks, the front track should be kept a little short of the width of the building and for this reason, I think it is best to fit up the side tracks first.

The length of the side tracks is six inches longer than the width of

half the door.

Fix the front track hard up to the under side of the side tracks and the length should be such that the hanger on the side track will just work past the ends.

Support the tracks with brackets at two or three foot centers. Concrete floors are the general rule in shelters of this class and when that is the case the floor guides and floor stops would be imbedded in the concrete and be used to hold the door in position either when opened or closed.

Single doors can be hung in much the same manner, only they require more room to turn around and of course the hangers must be of a heavier pattern since the two hangers slide the whole door, in place of two for each half.

When it is desired to have the side and front track placed on the same level, a special bracket is required to receive the ends of the tracks as shown. This bracket has its ends built into the front and side wall and is also fixed on the top flanges. In this case the door hangers would be of the same length. The great advantage in using the corner bracket shown, is when there is a lack of head room, as then the door can be arranged to slide around the corner in a small overhead space.

Anthony Zeman; His Shop

SELECTING a set of tools for general smithing is a matter of vital importance as, under prevailing conditions, the various changes in all the different branches has caused a great falling off of blacksmith work and it is well to be aware of the fact that a good portion of it will never make its appearance again, at least it would seem so, to those making a specialty of wagon and carriage lines. This should not cause the general blacksmith to become unduly alarmed. While many of the changes have apparently been of an alarming character the greatest number of them have proven beneficial rather than harmful to the business. For the work that has been lost in the way of wagon work there is a string of machinery taking its place and bringing with it an even greater amount of work. Considering that the automobile truck and passenger car requires a fair percentage of strictly blacksmith

work the same is true of the tractor. Aside from these there are numerous new agricultural machines, all requiring more or less of the smiths' attention. Therefore, to cover the broad variation of work, one must be equipped to meet its requirements, and in order to accomplish such, the old time forge, anvil and vise prove to be far too little equipment.

The accompanying illustrations show an interior view of my shop erected in 1917, as well as a floor plan of the same. There are many good features worth calling attention to. First the pieces of equipment being so arranged to occupy the least possible floor space. The shop is 18 by 38 feet and the equipment occupies the width of the shop and only cuts ten feet from its length, as indicated by the dotted line on the floor diagram.

The following is the equipment mentioned:

1—forge; 2—grinder; 3—coal-

bin; 4—coke crusher; 5—tooth-cut machine; 6—power hammer; 7—tire shrinker; 8—9—anvil; 10—drill press; 11—vise; 12—13—furnace and blower; 14—tong rack.

The checkered portion serves as a work floor and this is made of two thicknesses of lath. The bottom layer is laid at an angle, whereas the top layer runs lengthwise, forming a mat four feet wide and twelve feet long. It will be noted that one can stand on this mat while working at each of the principal tools on the floor with the exception of the drill press and tire shrinker. This mat is quite a convenience in the winter as without it the concrete floor is rather cold on the feet and it is easier to stand on than the bare concrete.

The figures 12 and 13 occupy the same space, as the blower is directly underneath the furnace. It is provided with two air pipes, one to the forge and the other to the furnace, each being provided with dampers so that the forge or furnace can be operated independently of each other or both at the same time. The furnace is especial-



A LOOK AT MR. ZEMAN'S SHOP SHOWS SUFFICIENT EQUIPMENT TO HANDLE ANYTHING THAT COMES ALONG

ly built for sharpening granite and other tools, whereas the forge is only used for general forging.

While this equipment would seem to be rather simple it will cover a broader range of work than one would realize.

To give a slight idea of the

have around the house.

The last job mentioned is making a barrel hoop. There are, no doubt, many different ways of making such a hoop but the easiest way that I have found is to cut the iron to the required length, take it to the power hammer and work it to

encouraged, thereby improving the morale of the fighting forces.

General Petain in a recent letter to Colonel Harvey D. Gibson, general manager of the Red Cross in France, says that the work of the American Red Cross was one of the prime factors in keeping the French army in fighting trim, and he intimates that many French soldiers will be kept under arms for some time yet, so the need of Red Cross service will continue for months after peace is arranged.

The canteen service is keenly appreciated by all the soldiers. American women and girls serve hot drinks, sandwiches and tobacco at hundreds of camps, railroad junction points, hospitals, and in the principal cities where the soldiers go on leave. It is at the railroad junction points that the American Red Cross makes the most profound impression upon the soldiers, for here the men change trains, and often must wait for hours before continuing their journey, and the canteens furnish a place to bathe, to sleep, read, eat, play games, or chat with the women workers.

Field canteens, operated by men Red Cross workers, are close behind the firing line and give the same service that may be found far in the rear. Millions of men are fed by these rolling canteens, and the cost of this one item runs into the hundreds of thousands of dollars.

The hospital service furnished by the Red Cross in France is chiefly at the base hospitals and in the cities. The field service, near the front, is done by the army nurses, and it is always well to remember that the Red Cross wherever it operates is always supplemental to the Army Medical Corps. For the last of 1918 the Red Cross appropriation for French hospital service is seven million dollars.

The Red Cross maintains one hospital which was used exclusively for soldiers gassed in battle. Patients of this character require particular attention and have made remarkable progress under the treatment worked out by American surgeons. Because several kinds of poison gases are used by the enemy, the cases must be treated individually.

An interesting phase of hospital service in modern warfare is the mobile hospital, which is taken from one battlefield to another. Auto trucks carry complete surgi-

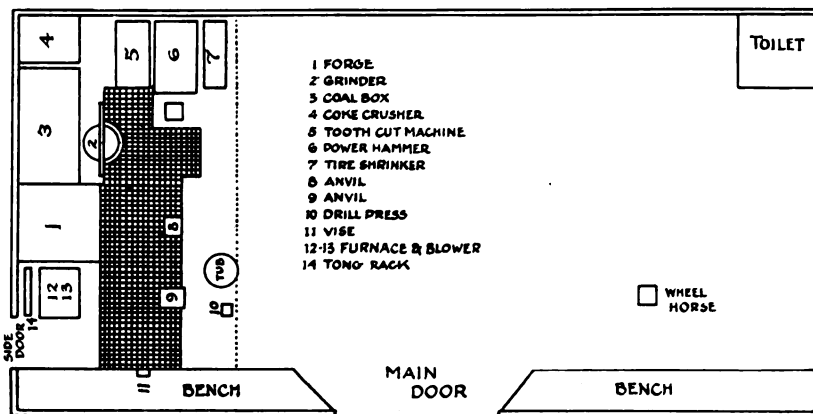

FLOOR PLAN OF THE ZEMAN SHOP

many different ways these tools will work, some sixteen jobs require the use of the forge, power hammer and anvil and then there are numerous other jobs that require the use of the furnace and anvil alone and still other jobs requiring the forge and anvil alone and often a job will need forge, hammer, anvil, vise, drill press and grinder combined and there are even jobs that require the power hammer alone, so it can be seen what a handy thing a power hammer is to

one side of the hammer dies which will have a tendency to work the iron on one side. By running the hammer at a reasonable speed it only takes about half a minute to shape the iron so that when it is turned into a hoop it has the required bevel.

Since each and every job has its just value, therefore, it is most important to cut down the length of time required to produce it and the equipment of the shop plays the principal part of the problem.

"Overseas" With Our Boys

THERE are upwards of five thousand American Red Cross workers in France, Belgium, England and Italy today. The variety of services given by these workers to our own soldiers and sailors, to the armies of the Allies, and to the civilian population would require volumes to describe.

The work in England is chiefly in the camps and hospitals and such emergency work as caring for the survivors of torpedoed ships. Approximately nine million dollars will have been spent in the United Kingdom by the end of this year.

Practically all the American wounded from our divisions brigaded with the British in Flanders are taken to England for treatment. This makes the hospital work in England of the highest importance to America, and the Red Cross is doing everything possible to assist

in making these hospitals, as well as the hospitals operated exclusively by the Red Cross, the best in the world. One of the services performed by the Red Cross is locating wounded American soldiers for their relatives and families, and sending news about them back home. More than five thousand volunteer workers, including American and English women, are engaged in this search.

In France, Red Cross activities by the end of this year will have cost seventy-one million dollars. A large proportion of this sum has been used in the civilian relief work, which has won such high praise from the French armies and civilian leaders. Refugees have been fed, clothed and sheltered, children have been saved for the future, and the families of French soldiers have been sustained and

cal equipment to any part of the front and there are portable kitchens, disinfecting plants and dental ambulances. The dental ambulances have all the latest instruments that may be found in an American dental office.

More than fourteen thousand graduate nurses have been enrolled by the Red Cross in the United States and turned over to the Army and Navy Medical Corps for service in this country and abroad.

In co-operation with the War Department, the Red Cross is assisting the families, relatives and friends of our soldiers and sailors to send each man a Christmas package in a specially designed container. Of course, both the government and the Red Cross would like to have every man receive as much as anybody wanted to send him, but the shortage of space on the ships make it essential to limit the size and number of packages at Christmas.

A new phase of Red Cross service that is growing rapidly is called hospital hut service, for which capable and attractive American girls are being recruited. It will be the duty of these girls to entertain convalescent soldiers. They will read to the men, write letters for them, plan entertainments, and fight the foe of homesickness, which must be vanquished if a speedy recovery is desired.

The extent of the co-operation of the Red Cross with the Army Medical Corps may be indicated by the statement that two hundred and thirty-one million surgical dressings have been shipped over-

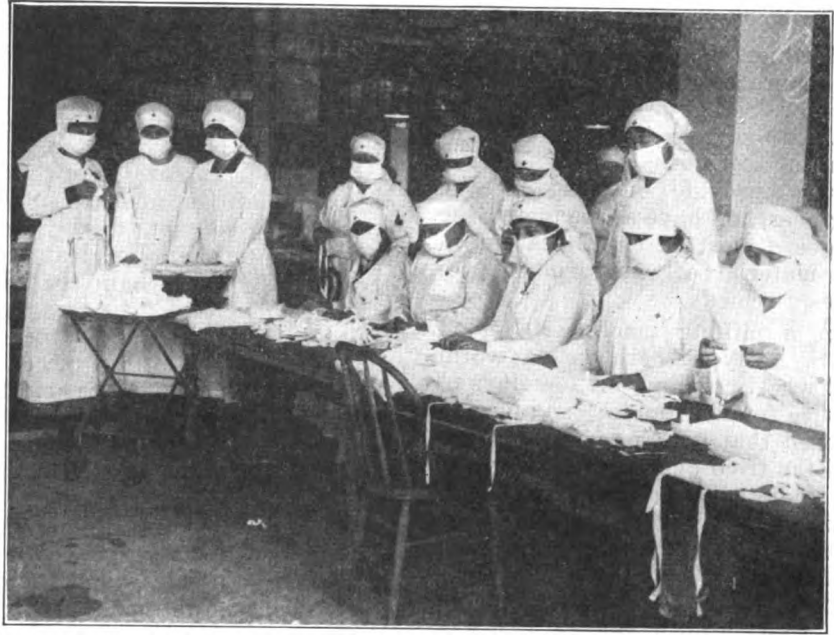

THE RED CROSS AT HOME—WORKERS TURNING OUT INFLUENZA MASKS IN RED CROSS WORKSHOPS

seas, and the monthly shipment of sterilized gauze has been one million yards, while ten thousand pounds of ether have been sent monthly. The Red Cross also shipped ten million, six hundred and thirty-seven thousand two hundred and one hospital garments and eight million, two hundred and three thousand one hundred and twenty packages of hospital supplies.

Public interest in the rehabilitation of men disabled in battle has reached a high point. The Red Cross is co-operating with the government in research work, maintaining in New York City an

institute for disabled men, where experimental work is done. It is the intention of the government to teach every disabled soldier a trade whereby he can support himself adequately. Men who have lost their legs are being taught stenography, motion picture operating, drafting, printing and many other trades, and those who have lost an arm are being supplied with new inventions which enable them to engage in a great variety of work. Farming is one of the favorite occupations of men disabled in the war. The government will not discharge from the army or navy any crippled man until he has learned to be self-supporting, and it is a notable fact that many of these men are earning more since they were crippled than they earned before the war.

It is to maintain the foregoing and many other forms of service to our fighting men and to their families through home service that the American Red Cross will conduct a Christmas roll call the week of December 16 to 23. What finer message could be cabled to our boys on Christmas Eve than that virtually the entire American people have enrolled in the Red Cross. Such a message also would mean a wonderful inspiration to the civilian populations of Europe because it would show that the American people are no less responsive to the needs of their fellow men in peace than in war. All anybody needs to answer to the Red Cross Christmas roll call is a heart and dollar.

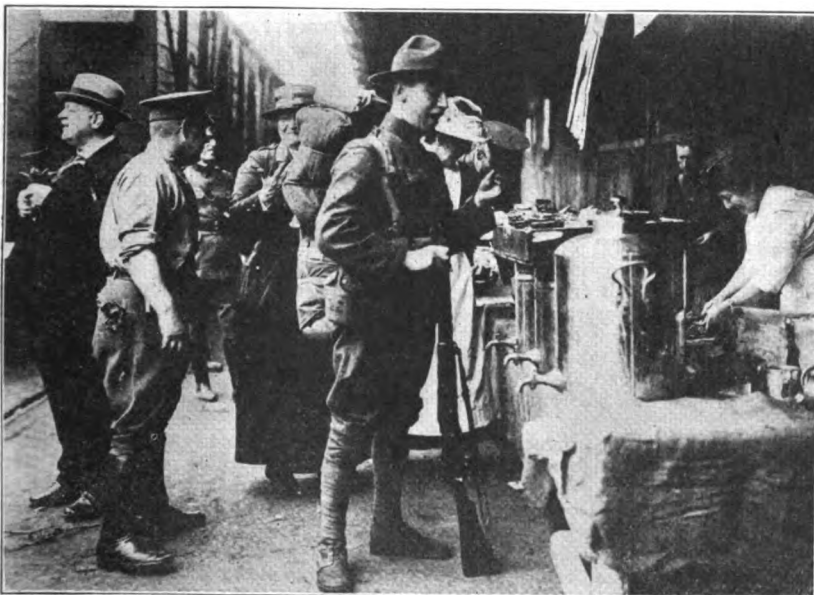

THE RED CROSS OVERSEAS WITH OUR BOYS—THE STATION CANTEEN IS A POPULAR THING WITH THE YANKS IN FRANCE

HARDNESS AND WEAR

Mark Meredith

Hardness is a metallic quality which practically defies definition; anyhow, recent attempts to define it are, to say the least of it, disappointing. Unusual cases of wear always provide interest to the engineer, and have a bearing on the subject: most often alteration in the material of one member provides a remedy.

In a milling machine of good U. S. A. type there was a worm and wheel meshing. A few days in service found trouble: examination showed that both worm and wheel had the tried and worn appearance as if abrasive had been used for lubricant, the teeth of the wheel were over one-third worn away and the worm itself scored.

The cause—steel worm and steel worm wheel both unhardened: the wheel was replaced, by one of cast iron, and gave no subsequent trouble.

In another instance a hand-actuated toggle press of simple type to stretch pieces of solid drawn tube to a shape unobtainable commercially was designed; at all events, although quotations were invited in several likely quarters, none were received, the quantity was moderate, and probably would not pay for special tools and usual drawing methods. Whatever the reason, it was decided to have the job home made, and a simple toggle drawing press was made up from available material. The screw was fixed at $1\frac{3}{4}$ in. diameter, for the reason that the shop possessed a pair of R. and L. square thread taps of that size, which were dug out from obscurity; and were a veritable find. The smith was commissioned to make two nuts and blank for threading, and no one gave a thought to material. The smith made screw blank nuts from the same steel bar. It took exactly twelve hours' work to produce fine steel powder, visible on screw and exterior of nut, and lubrication had no effect whatever, while turning the handle became a matter of horse-power. The job was disassembled, the screw cleaned up, and two gun-metal nuts obtained from a local foundry to a hastily made rough pattern. The job never gave trouble after, and the press used for occasional jobs has screw and nut threads in perfect condition after a lapse of years. The question of wear is not altogether one of hardness. Steel and cast iron

work perfectly together as a wearing surface, so also do the usual babbitt and bronze; but a mild steel shaft will not work with a mild steel bearing—try it and see. The shaft will cut and score, while if the pressure is considerable, as in a worm or pressure screw, the freezing qualities of the similar material in contact merely emphasizes the matter. Lubricant has literally no affect whatever; it is merely a vehicle to float away the disintegrated particles of steel as they are produced. Two pieces of steel glass, hard and perfectly polished, might slide for years, but such an instance is, to say the least of it, unusual in mechanical matters. Cast iron as a wearing surface is a puzzle. In engine cylinders, worn to a glassy surface, there are minute pin-holes, and a close examination shows that the harder points in the structure stand in relief. The essential beauty of cast iron as a wearing surface is the glaze or surface it acquires after running in under proper treatment. If from any cause the glazed surface, becomes abraded the cast iron wears with great rapidity, scores

and cuts up in a remarkable manner. Whether the material actually has a surface flow and gets an increased skin tension analogous to that produced in a fluid when solvent substances are introduced it is impossible to say, although theories to explain the facts are numerous enough.

The glazing property of cast iron is not without drawbacks. Possibly the largest single surfaces exposed to running wear in cast iron are those in the reciprocating marine engine. Guides, slide valves and cylinder surfaces are all of considerable size, and the glazing is very marked. Cast iron is by no means the hardest of known substances, but its resistances used by the engineer for wear resisting. This lends interest to the subject of hardness versus abrasion.

The glaze on cast iron after prolonged wear is extremely hard; in fact, on a large slide valve it can hardly be touched by a file under all the pressure a man can exert to make the implement bites.

When a large slide valve on a marine engine gets into this condition, efficient lubrication becomes



FREE TRACTOR SERVICE SCHOOL—The Avery Free Service Schools will be held at the following places, the school opening on the date mentioned.

Wichita, Kansas, Dec. 12; Omaha, Neb., Dec. 16; Lincoln, Neb. Dec. 19; Madison, Wis., Jan. 9; Des Moines, Iowa, Jan. 13; Sioux Falls, S. D., Jan. 16; Aberdeen, S. D., Jan. 20; Minneapolis Minn., Jan. 23; Fargo, N. D., Jan. 27; Grand Forks, N. D., Jan. 30; Billings, Mont., Feb. 3; Peoria, Ill., Feb. 13; Indianapolis, Ind., Feb. 17; Columbus, O., Feb. 20.

The schools will have two daily sessions, from 9 until 12 and from 1:30 to 5 p. m. The first day's instruction will include crankshaft, crank shaft bearings; connecting rod bearings, pistons and rings, valve grinding and timing, cylinder wall removing; clutch, general discussion; magnetos, impulse starters, care of magneto, care of starter, repairing magneto, spark plugs, discussion.

Second Day—Care of frame and gears radiators, etc.; How to operate, laying out fields, discussion; Carburetors and fuels care and operation of tractor, oil trouble, cooling system; operating other machinery; discussion.

The third day will be taken up by thresher instructions.

If you cannot attend any of the above schools, write the company's main office at Peoria, Illinois, for correspondence course of instruction, covering the following subjects;

The principles of a tractor motor; carburetor, care and adjustment; magneto, care and adjustment; bearings, adjustment and lubrication; valve grinding and timing; the belt and drawbar transmission systems; care and operation of the tractor. The company will also be glad to furnish any additional information desired in connection with these schools on request.

These free service schools are conducted that all may become more familiar with the care and operation of tractors, motor cultivators, plows and threshers. A competent Service Engineer from the factory will be in charge and you will be greatly benefitted by attending all of the sessions.

difficult; at all events, there is a decided tendency for the valve to squeak, and the trembling of the excentric rods show that it is difficult to propel. Usually high flash cylinder oil in quantity fed by a mechanical lubricator will not effect a cure. The only remedy is to break up the surface of the valve at the earliest opportunity, and every marine engineer is aware of the necessity and deplors the hard work involved. The breaking of the skin on the valve with coarse block files does the trick, while the seating is very rarely touched, except that at long intervals it becomes necessary to re-machine both valve and seat. It appears therefore that under conditions of large area and considerable pressure with the temperature usual to steam practice that the skin of machined cast iron under-goes a molecular change, beneficial up to a certain point and then detrimental to running. The same remarks apply to the large guide surfaces and crosshead slippers; the face of the latter benefits from breaking up with a file from time to time; in this latter case great care has to be given to the guides until the glazing is again produced by wear.

Some folk consider cast iron as a rather inelastic material; this, in spite of well-known constructions (mainly clamping arrangements) which prove the contrary. If a large guide gets hot by neglect the water passages get choked in its interior economy. When taken down, (the only method of clearance, and involving some troublesome tackle to effect) the guide, a casting over 2 in. in thickness was warped 6 in. cornerwise from the flat. It was replaced, pulled into position with its securing bolts, and never gave trouble after. Breaking up the surface of both guides and slipper with files, and a little care lavished when started up again, gave perfect running results. There can be no connection between the modern methods of penetration and rebound test and wear in the case of cast iron.

There is good authority for the statement that cast irons giving the same Brinell hardness differs widely in wearing qualities. Moreover, the question of abrasive hardness wear resistively can only be ascertained in use. Doubtless, the cause of some cast iron wearing better than others is a question of chemical composition, a cast iron which machines like cheese may wear well so long as it is close grained, and

does wear well in use. It is a matter of the only real practical test—that of actual use—which will settle the matter. Cast iron is a very complex substance, it has to please the foundry in that it will turn out sound castings with the minimum of trouble in cupola, and it has to please the engineer by durability for wearing surfaces. In face of the known facts concerning this commonest of mechanical materials it is little wonder that the definition of hardness recently made is nearly as complex as cast iron itself.

WEIGHT OF SQUARE STEEL BARS UP TO 2"

(For Iron, deduct 2%)
Pounds per lineal foot.

| | | | |
|---------|--------|---------|--------|
| 1/8 | .0531 | 1 3/4 | 10.413 |
| 9/64 | .0672 | 1 25/32 | 10.788 |
| 5/32 | .0830 | 1 13/16 | 11.170 |
| 11/64 | .1004 | 1 27/32 | 11.558 |
| 3/16 | .1195 | 35/64 | 1.0168 |
| 13/64 | .1403 | 9/16 | 1.0758 |
| 7/32 | .1627 | 37/64 | 1.1364 |
| 15/64 | .1868 | 19/32 | 1.1986 |
| 1/4 | .2125 | 39/64 | 1.2625 |
| 17/64 | .2399 | 5/8 | 1.3281 |
| 9/32 | .2689 | 41/64 | 1.3954 |
| 19/64 | .2997 | 21/32 | 1.4643 |
| 5/16 | .3320 | 43/64 | 1.5348 |
| 21/64 | .3661 | 11/16 | 1.6070 |
| 11/32 | .4018 | 45/64 | 1.6809 |
| 23/64 | .4391 | 23/32 | 1.7564 |
| 3/8 | .4781 | 47/64 | 1.8336 |
| 25/64 | .5188 | 3/4 | 1.9125 |
| 13/32 | .5611 | 49/64 | 1.9930 |
| 27/64 | .6051 | 25/32 | 2.0752 |
| 7/16 | .6508 | 51/64 | 2.1590 |
| 29/64 | .6981 | 13/16 | 2.2445 |
| 15/32 | .7471 | 53/64 | 2.3317 |
| 31/64 | .7977 | 27/32 | 2.4205 |
| 1/2 | .8500 | 55/64 | 2.5110 |
| 33/64 | .9040 | 7/8 | 2.6031 |
| 17/35 | .9596 | 57/64 | 2.6969 |
| 31/32 | 3.1908 | 29/32 | 2.7924 |
| 64/64 | 3.2946 | 59/64 | 2.8895 |
| 1 | 3.4000 | 15/16 | 2.9883 |
| 1 1/32 | 3.616 | 61/64 | 3.0887 |
| 1 1/16 | 3.838 | 1 7/8 | 11.953 |
| 1 1/32 | 4.067 | 1 29/32 | 12.355 |
| 1 1/8 | 4.303 | 1 16/16 | 12.763 |
| 1 5/32 | 4.546 | 1 31/32 | 13.178 |
| 1 3/16 | 4.795 | 2 | 13.600 |
| 1 7/32 | 5.050 | | |
| 1 1/4 | 5.313 | | |
| 1 9/32 | 5.581 | | |
| 1 5/16 | 5.857 | | |
| 1 11/32 | 6.139 | | |
| 1 3/8 | 6.428 | | |
| 1 13/32 | 6.724 | | |
| 1 7/16 | 7.026 | | |
| 1 15/32 | 7.335 | | |
| 1 1/2 | 7.650 | | |
| 1 17/32 | 7.972 | | |
| 1 9/16 | 8.301 | | |
| 1 19/32 | 8.636 | | |
| 1 5/8 | 8.978 | | |
| 1 21/32 | 9.327 | | |
| 1 11/16 | 9.682 | | |
| 1 23/32 | 10.044 | | |

Example—To find the weight of 6 feet of 31/32 steel rod, multiply the number of feet by the weight per foot (3.1908 x 6 or 19.1648 pounds). To find the weight of the same amount of iron bar, multiply the product by .02 (18.1648 x .02 or .383296 or a trifle less than 2/5 of a pound) less than the same amount of steel.

TRACTOR AND HORSES

A dependable tractor is more economical, for practically all the heavy work on the farm, than horses.

Its cost is less than that of the horses it replaces in heavy work. It requires less time and care than do horses. In comparison with horses, let us consider that "The best is none too good," and take as an example the high-grade 4-plow tractor selling up to \$2,000.

One of these tractors will do the same amount of fall plowing that \$2,000 worth of horses can do in nine hours. Nine hours of constant draft each day is all that horses can endure throughout the plowing season. But the tractor can easily be kept working at full capacity fourteen hours per day.

Our agricultural experts have been telling us, and we have found it to be true, that fall plowing is necessary, especially for small grain. In addition to enable the soil to assimilate the decomposed trash and receive the benefit of nature's chemical action during fall, winter and spring, fall plowing gives us an opportunity to get our corn ground ready and the seed planted at the right time.

There would have been practically no late planting of corn, even in this wet spring, had we done the plowing we should have done last fall.

One man can turn four furrows with a tractor more easily than he can two with horses. This results in a saving of help.

Another valuable lesson we have learned from the agricultural college, the older farming sections of country, and from our own observations, is the benefit of deeper plowing. This gives the plants a deeper root-bed and provides a larger moisture reservoir; which in turn results in a form of insurance against the effects of dry periods which frequently occur during the growing season.

In favoring our horses, that we may get all the ground turned and our seed sown at the proper time, we are inclined to plow more shallow that we know we should.

With a good tractor pulling the load for which it is recommended, we can keep our plow cutting the desired depth throughout the season.

Some tractors are so constructed that they are successfully and economically used in all work, from plowing to the harvesting and threshing of the crop.

J. W. Brainard in Dakota Farmer.



FAITH

Out in a world of mud and woe,
Lost in a riot of blood and pain,
Billets of rest (they call them so)
A breathing space, and the line again,
Just one thing tells me that still, some-
where,
Mothers sit in the lamplight glow,
Children still whisper their bedtime
prayer,
As they always did. I know—I know—
Wounded and weary, a month ago,
A Red Cross nurse with an angel's smile,
Came to my cot and told me so,
And made me remember, a little while.

by Jeanne Judson

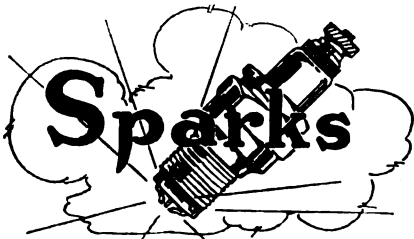

New Jersey girls working on piece work have been making as much as eight and nine dollars a day. No wonder it is hard to get them to do a little biscuit shooting.

In counting the cost it never seems necessary to allow for shrinkage.

Waiting for your ship to come in is a pleasant job but it don't buy any bacon.

Some people couldn't even drive a nail without doing crooked work.

Popular debating subject—"What to do with the Kaiser."

You never can tell. Even modesty loses its charm when people boast of it.

Have you sent us a helpful letter or suggestion during the past year that would benefit someone else by its publication? Start the New Year right and let us hear from you often, even if you only talk about the weather, we'll be glad to hear from you.

It isn't safe to call a policeman a lobster unless you want to get pinched.

The Bolsheviks seem to have some queer ideas on liberty and freedom of speech—if you differ from their ideas you get shot.

The game laws provide no closed season for the fellow who is hunting for trouble.

There isn't enough hemp in the world to make neckties for all the pests of the human race and we suppose that's the reason so many of them remain unhung.

Horse Vs. Tractors—We present herewith arguments for both the horse and the tractor in farm use. This data comes from a Texas newspaper and seems to us sufficient argument for the gasoline vehicle over the hay motor:

This is a list of points in favor of horses:

"They have stood the test for centuries of useful service.

"Their feed can be grown on the farm and they help raise it.

"They are self-producing and give about twenty years of service.

"Their manure is a valuable farm by-product.

"They are intelligent and in some work may be directed simply by word without need of rein, thus saving the services and expenses of one man.

"They can go through water, mud, timber, and over rough and hilly places with comparative ease.

"Though normally developing less than one horsepower, a horse can in an emergency, and for a short time, exert three or four horsepower.

Here are some points in favor of tractors: Tractors satisfy the demand for power to pull heavy machinery such as large gang plows, corn pickers, and road machinery. This work is too hard for horses.

"Tractors can do belt work such as running ensilage cutters, grinding mills, and other high speed machinery. This work cannot very well be done by horses.

"Tractors need not be rested in hot weather, and are not 'soft' in the spring when they are needed most.

"Tractors are not affected by flies, bees, and sickness which may entirely upset and delay a season's work.

"Tractors require no fenced pasture land nor expensive barns, nor harness. They need but a simple shed for storage.

Sure the Bolsheviks are against all capital except capital punishment for those who don't think as they do.

Now that the war is over we'll have to read all about fool congressmen, the sacred tariff and a lot of other things that we have been spared for the last four years—Good Lord deliver us!

The chief difficulty about the labor situation is that a large number of people know too much to work with their hands and who don't know enough to work with their brains.

In olden times the kings used to keep fools. They know better now—the fools keep the kings.

Won't someone PLEASE tell the profiteers that the war is over?

A Syracuse newspaper suggests a supplementary peace proposition to the President's fourteen. "Unless otherwise disposed of, the Crown Prince must grow a full beard, wear smoked glasses, and take other steps that may be suggested later to disguise a mug of which the world has become very tired."

Missing—Not that it matters a whole lot, but—what becomes of all Wooden collar buttons sent home from the laundry; Swatted flies; Bent pins; Dull safety razor blades; Golf scores; Old fly screens; Resolutions we made last January.

Dangerous Experiments—A man rocked a boat to see if it would tip. It did.

A laborer stepped on a nail to see if it would go through his shoe. It did.

A man looked into the gun to see if it was loaded. It was.

A press hand kept his foot on the treadle to see if it would repeat. It did.

A woman looked into a patent medicine booklet to see if she was sick. She was.

Last June a helper smelled escaping gas and lit a piece of oily waste to find the leak. He found it.

A drill press hand wore a pair of gloves to see if he would get caught. He was.

You never can tell—It isn't always the best fighter who quibbles over the price of peace.

No, it isn't expected that the closing of the munition factories will entirely

dispose of the shell game. Look for it at the fair next fall as usual.

Among those on the retired list at the conclusion of peace, look for the name of General Mars.

Many a man when confronted by temptation merely throws up his hands and yells: "Kamerad."

OLD JENNY IS DEAD

Old Jenny horse was a fly-blown bay with streaks of red and streaks of gray, and a brain that worked like a load of hay piled up on the old barn floor.

The man who owned her was Hiram Gray, who has long since traveled the golden way, and it's evident he consented to stay, for he never came back any more.

He used the old mare to deliver doors and white pine sash and hardwood floors and perform a thousand-and-one old chores in her slow and leisurely way.

Old Jenny had legs the size of a plate, which were curved to resemble the figure eight, and her ribs showed up like a strawberry crate on a frosty morning in fall.

They buried two men she had savagely kicked and two more were mangled and fearfully nicked in a free-for-all fight; she had never been licked with crowbar or hammer or maul.

Old Jenny was hungry the day she was born and the void in her stomach was yelling for corn, and every hour in her life from the day of her birth she destroyed more food than her old hide was worth.

She went to her work with a down-trodden air that would draw the hot tears from a grizzly bear, and every two days this old piece of cheese would be sick with the colic or lame in both knees—the deceitful and wicked old mare.

Two times in the night when it started to freeze old Hiram brought blankets and doughnuts and cheese, and then this old jade, when she knew he was gone, ate two bales of hay and a bag of cracked corn, and the rest of the night she would hiccough and sneeze and groan and snuffle and yawn.

She had ringbones and spavins and a boil on her neck and a bare, hairless spot on her hurricane deck, where Hiram had started a brisk little blaze when she balked in the snow for a night and two days. Then that very same day, without further alarm, she bit a big hunk out of Hiram's right arm, and pulled out his whiskers and planted both feet on that soft, rounded spot where his overalls meet. Wasn't that spiteful and mean when 'twas plain to be seen that Hiram intended no harm?

Hiram stood high in the church when he bought the old mare and it gave him heart failure to hear a man swear, and 'tis said 'twas his custom to hide in the barn when he felt he would bu'st or whisper "gol-darn!"—but after he'd wrestled with Jenny a week he would jump on his hat and swear a blue streak.

Both Hiram and Jenny are with us no more, they are having their troubles on some other shore; but where Hiram and Jenny were busy all day carting one load of shingles a few miles away, a gasoline truck is delivering the goods, driving horse-power competitors back to the woods.

It never stops to stuff hay and grain or lie down and roll with a colicky pain; and when our thoughts turn to the mountains of hay and bushels of grain she destroyed every day, every night when we kneel by the side of our bed we thank the good Lord that old Jenny is dead.

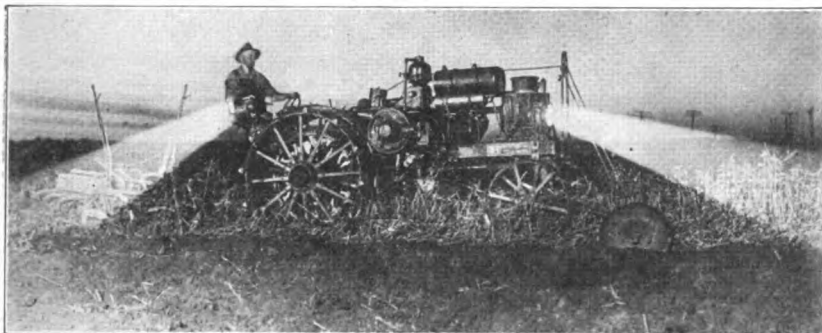

MINNESOTA FARMER BY DAY AND NIGHT PLOWING SAVES ENTIRE CROP

L. S. Thom is a Minnesota farmer, he believes in plowing early and deep. His crops were coming along fine when a hail storm beat them down, but undaunted, he started in immediately to re-plow his ground to put in a second crop. In order to get his crop in as early in the summer as possible, before harvesting began in his vicinity, he ran his 8-16 tractor outfit with a headlight in the front and one in the back, continually, eight days and nights, stopping only for fuel and water, until his work of plowing was done. He realized quick action was needed and by running shifts the work was accomplished with the aid of his tractor in short order.

He started out the previous year and says, he plowed eighty acres of the hardest plowing he had ever seen, pulling three 14 in. bottom plows 6 in. deep with his 8-16. Another time he pulled a potato digger, and in the forenoon of one day gained seventy-two rod runs on the horses. He also hauled 3500 bushels from the field to the cellar, a distance of about 1½ miles, four loads at a trip with 80 bushels to the load, or 360 bushels in a trip. At another time he pulled a 15 in. Ohio Cutter, filling two 150 ton silos in six days, these silos being 40 feet high.

This was just some of the work he accomplished in the first sixty days that he had his tractor last year. The silo filling could not have been done by horses.

Mr. Thom says a man can farm cheaper and more successfully with a tractor than with horses, and is also relieved of having so much hired help about the place.

He reported some actual figures on the cost of this work with the tractor and what the probable cost with horses would have been. He said if he had done this same work with horses, it would have cost him 2½ times as much as it would with motor power. The tractor would haul four loads of potatoes from the field to the root cellar at noon while the horses were eating and again, at night when the horses were taken to the barn for rest. He could not have plowed his land at night after the hail had destroyed his crops, if he had used horses, but by using his tractor he got in his second crop in time to allow a good growth before the heat and burning sun of the dry summer season.

STITCHES IN TIME

Watch out for steam at radiator cap, at it indicates that the engine is overheating, a condition which may result in serious damage to the engine if not taken care of in time. Overheating burns up the oil, causing friction, loss of power, scored cylinders, broken parts and possibly a bent crankshaft and cracked crank case.

Another symptom is knocking of the engine. This is more pronounced on a hill, but may occur with the engine under load. This will take place with spark retarded, showing it is not a spark knock. It may be due to glowing carbon, unless the carbon has been removed. Remove a spark plug. If the end is badly carbonized it is probable a carbon knock, but a knock accompanied by steam at the radiator is usually due to overheating.

Overheating is also shown when the engine runs with the switch open (in the "off" position). This may also be due to carbon, and the spark plug should be examined. To stop an engine running without the electric spark, throw out clutch, put gears in high speed, apply foot brake gently, throttle down and let in the clutch. This stalls the engine.

The usual causes of overheating are running too long on low or intermediate gear, racing engine, failure to pump, clogged radiator, leakage of water from the system, etc. The engine may also be overheated by running with retarded spark and throttle too wide open.

Clogging of the cooling system may be prevented by cleaning at least twice a year with sal soda. Dissolve about two pounds of it in hot water and pour into radiator, running the car as usual. After a day's use, drain the radiator and fill with clean water, changing the water again the next day. This will remove the scum that forms in the system, especially the radiator.

Radiator hose connection should be frequently inspected. Quite often these look good from the outside, but they are defective on the inside. When the walls of the hose become decayed they have a tendency to swell and close, thereby preventing proper circulation.

Care should be exercised not to use hard water in the cooling system. Water containing minerals will cause a scale to form on the inner walls of the whole cooling system. Soft water or clean rain water is the best to use

Benton's Recipes

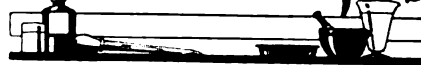

Strop Paste for Razors and Keen Edge Tools.—An excellent strop paste for edging razors or other keenedge tools is a mixture of levigated oxide of tin, 1 ounce; powdered oxalic acid, ¼ ounce; powdered gum, 20 grains. Mix to a paste with water, spread evenly over, and work well into the strop with some smooth surface. The rough side of the strope gives best results.

To Produce a Gray Color on Brass.—First clean off with alcohol, polish the surface to an even finish, making sure that grease or finger marks are removed. Then immerse in a solution of one ounce of arsenic chloride to one pint of water until the desired color is obtained. Wash in clean, warm water, dry in boxwood sawdust, warm, lacquer with a thin pale solution of bleached shellac in methyl alcohol, using a broad camel's hair brush.

To Clean Jewelry, Silverware and Metals.—The following receipt is one that not all jewelers know. It can also be used to clean the hands on special occasions; it will not crack the hands if vaseline is rubbed in well immediately after rinsing them off in water:

Make a saturated solution of cyanide of potassium by taking a quantity of water, and dissolving the cyanide in it, until no more cyanide will dissolve. Dip the article in this solution until the dirt is eaten off (this takes but a short time) then rinse off in hot water, and dry in boxwood sawdust. The article will then look better than when new.

Etching on Copper.—For acid resisting ground use a mixture of 2 ounces white wax to which when melted is added 1 ounce fume mastic in powdered form, a little at a time, until the wax and gum are well mixed. Then, in the same way, add 1 ounce powdered bitumen. When this is thoroughly mixed add to it ½ of its volume of essential oil of lavender. This should be well mixed and allowed to cool. The paste can be applied with a hand roller, and if it is too thick, can be made to flow easier by adding a little more oil. When the paste is applied to the copper plate, expose it to a gentle heat in order to expel the oil of lavender. For a biting or etching acid use a mixture of 5 parts of hydrochloric acid, 1 part of chlorate of potash and 44 parts of water. The water is heated and the potash added. The acid is added first when the potash is fully dissolved. The mixture is used by immersing the whole object to be etched, the object, of course, first being covered on all sides by the acid resisting ground.

Bicycle Tire Anti-Leak.—Many machinists ride their bicycles to and from work and are consequently interested in anything that will make tires more nearly puncture-proof. I have not tried the following anti-leak compound, but infer from a note in the English Mechanic that it works successfully on both single and inner-tube tires. Mix ¼ pint of silicate of soda (water glass), ¼ pint of commercial glycerine and a large tablespoonful of rubberine; inject about a teacupful into the tire. If too thick, a little water can be mixed with it to thin it. If rubberine is not available use powdered rosin.

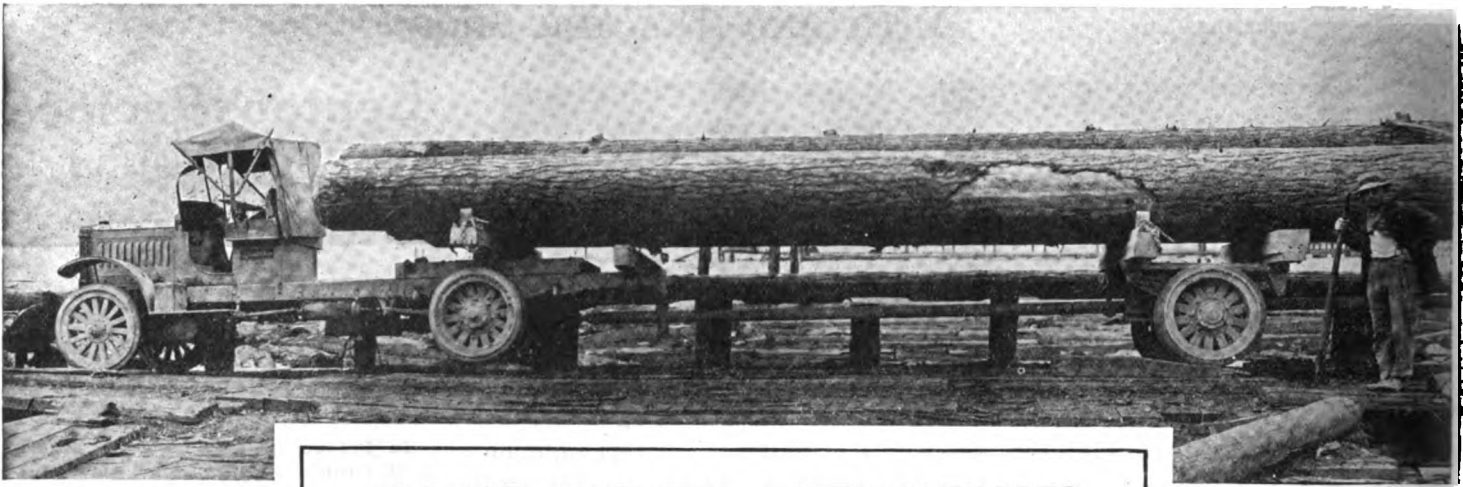

**MOTOR TRUCKS—THE NATION'S
SECOND LINE OF DEFENSE**



A BIG YANK TRUCK HAULS THE CUBAN ARMY'S RICE FOR DINNER

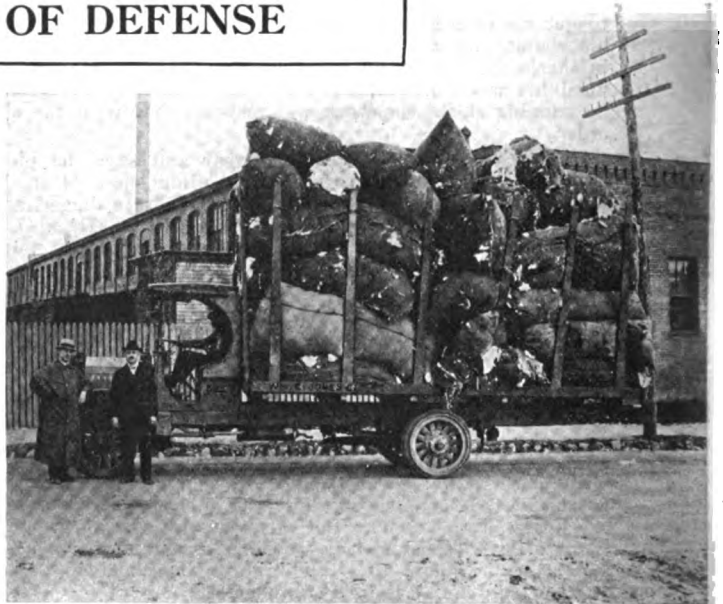

GIVING OLD KING COTTON A "LIFT"



THE MOTOR TRUCK IS THE FASTEST AND CHEAPEST METHOD OF TRANSPORTING FARM PRODUCTS FROM THE FARM TO THE USER

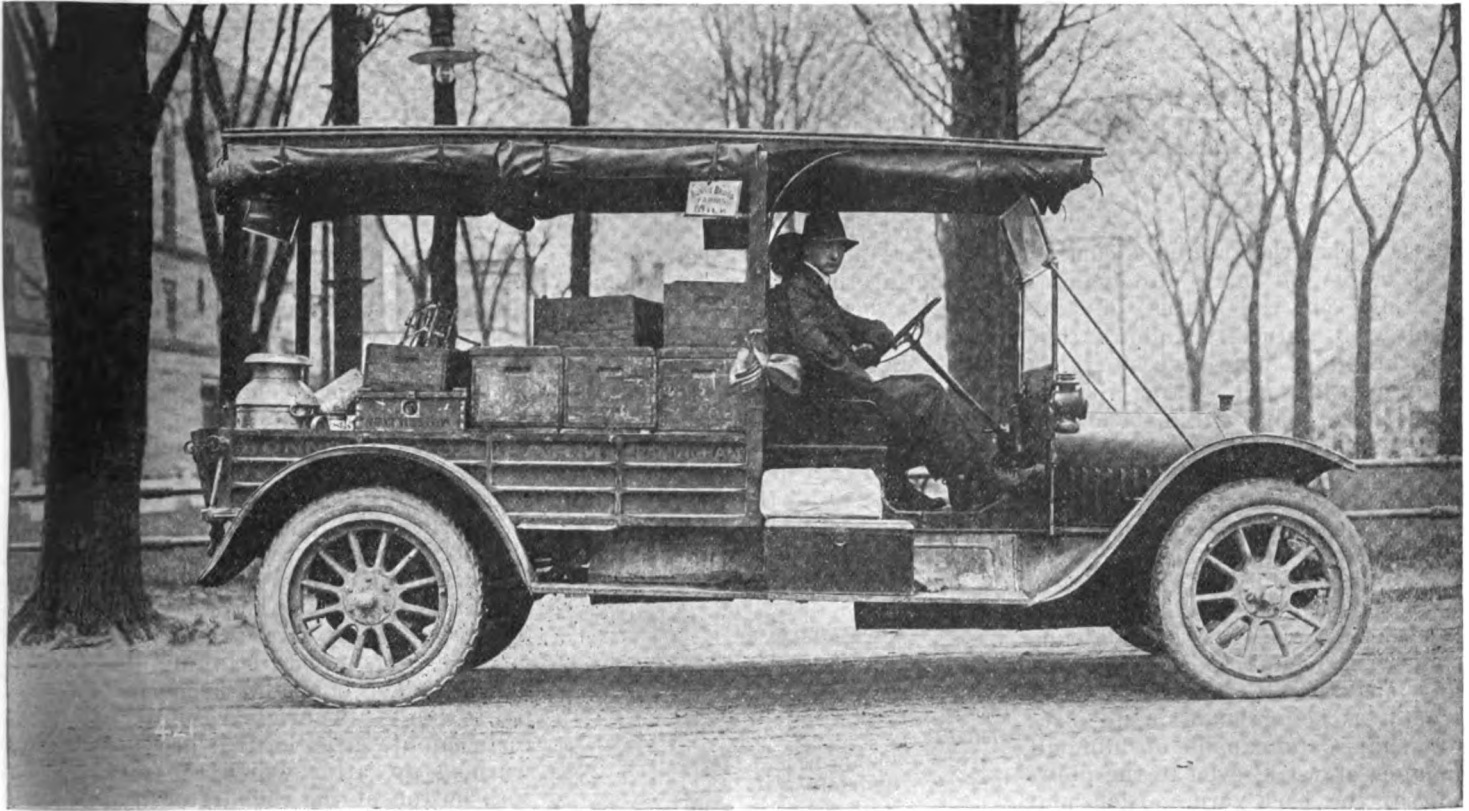

THE "ONE HORSE" FARMER CAN PROFITABLY USE A SMALL TRUCK



TRUCK AND TRAILER CARRYING 100 BAGS OF WHEAT



THE MODERN WAY OF HAULING HAY



A TRUCK THAT RUNS DAY AND NIGHT HAULING MILK



A HEAVY TRUCK FOR LONG DISTANCE WORK

Making Tractor Starting Easy

ALBERT MARPLE

NOW that the tractor is coming more and more into general use on the farms of this country it naturally follows that as the days and weeks wear into months and years farmers in general are giving more and more consideration and study to the "farm bug". The "old bay mare" may be all right in her way, but the farmer of today is gradually realizing that her day is past so far as doing field work on the average-sized and large ranch is concerned, and, in truth, this might be said with regard to the ranch of any size at all for the modern tractor is being made in all sizes and shapes and capable of doing all manner of work, even to the plowing of the back-yard garden plot—the Liberty garden. In other words, the tractor is coming into its own. Because it has shown that it can produce the goods it has been given a steady job.

But like every other piece of machinery the world has ever known, the tractor has its peculiarities. For instance, it refuses to "mote", now and then, and then there are times when it does its work in a half-hearted fashion. When conditions of this kind arise it is the easiest thing in the world for the owner to administer blessings upon the tractor, the salesman and the tractor manufacturers as a whole, never realizing for a moment that the cause of the trouble is that the machine is not "right". When the human machine has a bad case of indigestion it goes to bed for a week, but when the tractor, because he is being fed the wrong kind of food, gets a little out of sorts, as they say, he's supposed to do his work just the same—and the good old "bird" keeps a plugging 'till he falls down—a wreck.

One of the outstanding drawbacks to the modern tractor is that he refuses, at times, to start on cold mornings—and on other mornings that are not so very frigid. He stands there like a great bunch of junk and refuses absolutely to "cough". The farmer fumes and frets, but that never started a tractor.

When viewed from practically every angle the starting of the

tractor is almost identical to that of starting the average automobile. That is, both require the proper mixture, a hot and properly-timed spark, etc. If any one point is out the motor cannot reasonably be expected to do its work properly if at all. The tractor owner must understand that in order to explode properly or at all the vapor coming from the gasoline or distillate must be mixed with the proper amount of air, just as is the case with the



common gas in the kitchen range. This is proven by the fact that if, when the motor is purring along nicely, the mixture is made excessively rich the engine will begin the sputter and finally die. When starting the tractor motor the tendency is to "give 'er more dis". Consequently the mixture is made richer and richer, the farmer thinking it has not yet "reached the proper point". The result is generally that the carburetor is flooded, which condition is the fore-runner of a merry time.

The fact of the matter is that when the mixture had reached the proper point the motor for some reason failed to explode, then as the mixture was strengthened it became too rich to ignite. If the motor does not shoot after the mixture has been enriched to a reasonable degree, time and trouble will be saved by turning it over a few times without the priming rod pulled out, until all of the too-rich gas has been expelled from the cylinders, and beginning all over again.

When about to start the motor it is a good plan to first squirt into the cylinders through the plug openings or priming petcocks, a limited amount of high grade gasoline—say a spoonful. Benzine will serve this purpose very well. This

high-gravity fluid vaporizes much more readily than does the distillate and for this reason will ignite more rapidly. After priming in this way it is advisable to wait a short time before commencing to crank, as the fuel must have time to vaporize. After priming and before cranking give the button which regulates the flow of distillate to the carburetor about half a turn around, enriching the mixture, so that when the motor shoots on the gasoline vapor it will be immediately supported by a rich distillate mixture. If, upon cranking the engine starts, it should be permitted to run in its enriched condition for a minute or so until it becomes warmed up, after which the mixture button of the carburetor may be turned back to its proper place. Some farmers have arranged an auxiliary priming gas tank somewhere on the car. From this a pipe runs to and enters the intake manifold of the engine. When it is desired to start the motor some straight gasoline is run from this tank, through the pipe into the manifold, then at the first turn of the starting crank, the gasoline vapor is carried into the cylinders of the motor where it is rapidly ignited.

It must be remembered that more gasoline or distillate is required in a cold motor than in a warm one, and the warm motor is much more easily flooded with a rich mixture than is a cold one. Most tractor operators are familiar with the practice of heating the carburetor to facilitate starting in cold weather. However, comparatively few persons, it seems, realize the necessity and value of heating the intake manifold at the same time. The reason for heating the manifold is easily understood when it is explained that the gasoline, although vaporized in the heated carburetor, will often recondense on the cold walls of the manifold. Heating the carburetor is, at the best, a risky operation, unless some means is devised whereby no fire or spark can possibly come in contact with the gasoline or gasoline vapor. One comparatively safe method of heating the fuel is to place the priming can in hot water.

It is definitely known that by

heating the water in the radiator good results may sometimes be obtained. The operator should, however, exercise care in pouring in the heated water. After the water has been heated it should be poured through the radiator intake pipe, and in order that the motor may not be caused to heat too rapidly, the drain petcock at the bottom of the radiator should be opened and the hot water poured in the top as rapidly as the cold runs through the petcock.

Another valuable point in obtaining easy starting of the tractor is in keeping the plugs clean and properly spaced. Points that are carbon covered cannot reasonably be expected to do their work properly. The too-far apart and the too-close points will also cause trouble. The points should be about the thickness of a dime apart. If a high tension magneto is used a hot or "fat" spark will result, thereby making starting easier.

A forward step in tractor manufacture is the placing on several of the machines of starting devices. One tractor manufacturer, at least, has included an electric starter in the equipment of his machine, and it is not unlikely that even now other tractor makers are considering or carrying out this much-needed improvement. A western inventor has installed on several tractors in his section, a compressed air starter which is said to be effective, especially on the larger machines. An air compressor is driven by the tractor engine and automatically cuts off when the pressure in the storage tank has reached a certain point. This tank, it is said, will hold enough air to start the engine under the most trying circumstances.

A number of other starting devices are being adopted by the different manufacturers. One type in general use is the "compulsion" starter, a contrivance for spinning the magneto shaft at a high rate of speed while the motor is being turned over at slow speed. This rapid movement produces a hot, "fat" spark, for starting and continues until the engine has attained a speed of about 200 revolutions per minute, when it is automatically thrown out of gear.

One of the latest types of tractors is equipped with an auxiliary engine, of one horse power, which is a complete power plant in itself—air cooled and started on batteries. The little motor may be engaged

with the flywheel of the larger machine by means of a friction wheel and is capable of spinning the larger engine. Another starting scheme is a ratchet lever, the handle of which is engaged in holes placed at intervals in the flywheel, and a locking device which holds the engine at a point where one of the cylinders is ready to fire. With this latter equipment the starting cylinder is connected to a hand pump and sufficient pressure is pumped into the cylinder to start the engine when the electric spark is generated. The locking device, although of sufficient strength to hold the engine against compression, releases when the explosion takes place.

To put the tractor in condition for easy starting in all kinds of weather and to keep it there is one of the biggest jobs connected with the tractor. It is largely a case of having things "right". If everything is as it should be the chances are that the motor will "mote" when her "tail is twisted." To keep the motor in this condition, the farmer must understand the machine. This "understanding" cannot come in a day, but may take weeks and even months. The only way to "turn" this starting trick is to give real thought and study to the subject—learn the principals of easy starting and then apply them.

THE FUTURE OF THE AUTO INDUSTRY IN BRITAIN

John Y. Dunlop

As most people know, the motor car and tractor factories of England and Scotland have played a very prominent part in helping on the war.

Immediately after the outbreak of hostilities the Ministry of Munitions set about commandeering the personnel and equipment of the plants and now practically every establishment previously devoted to the work of manufacture of parts, is engaged in turning out guns, shells and other munitions of war or in building lorries for army transport work or engaged in the production of tractors for the tillage of the country to assist in the food campaign.

It was fortunate at the outset that the organization of these factories had reached such a high standard and that the industry was on a scale sufficiently large to enable the required changes to be made quickly and turn to the large

production of munitions almost immediately.

As the end of the war comes in sight, it is natural that all connected with the industry should be speculating on conditions as they will exist when peace returns and it is equally natural that the views held should be widely different.

On the one hand it is thought that owing to the shortage of money and the high taxation that the motor industry is sure to suffer and will require a long time to recover. But there are others who view the situation optimistically and with quiet confidence.

Few men are better able to judge the situation than the present president of the Institution of Automobile Engineers who, in a recent address to the members on the influence of the war on the industry, pointed out that the motor car is a necessity of civilized life no matter on what side we look and argued that conditions obtaining after the war will accentuate this fact, if for nothing else than the time saving features of the motor car.

Although the high cost of living would mean high cost for materials and labor the motor business must flourish and though there would be a pronounced demand for cheap cars, tractors and transports, there must continue to be a market for every class of vehicle for which there was a market before the war, and, a greater demand.

The president laid great stress on the fact that while prices may be higher than in 1914 they will compare favorably with the pre-war prices of other commodities and he explained the need for greater standardization, providing that the principle be carried out on rational lines.

The speaker ventured the opinion that the diversion to war work will be found to have been of great benefit to all concerned and that the few firms who have been left to pursue their normal activities will actually be worse off than those who have been commandeered, by reason of the experience gained.

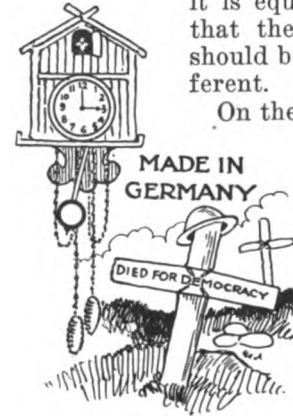

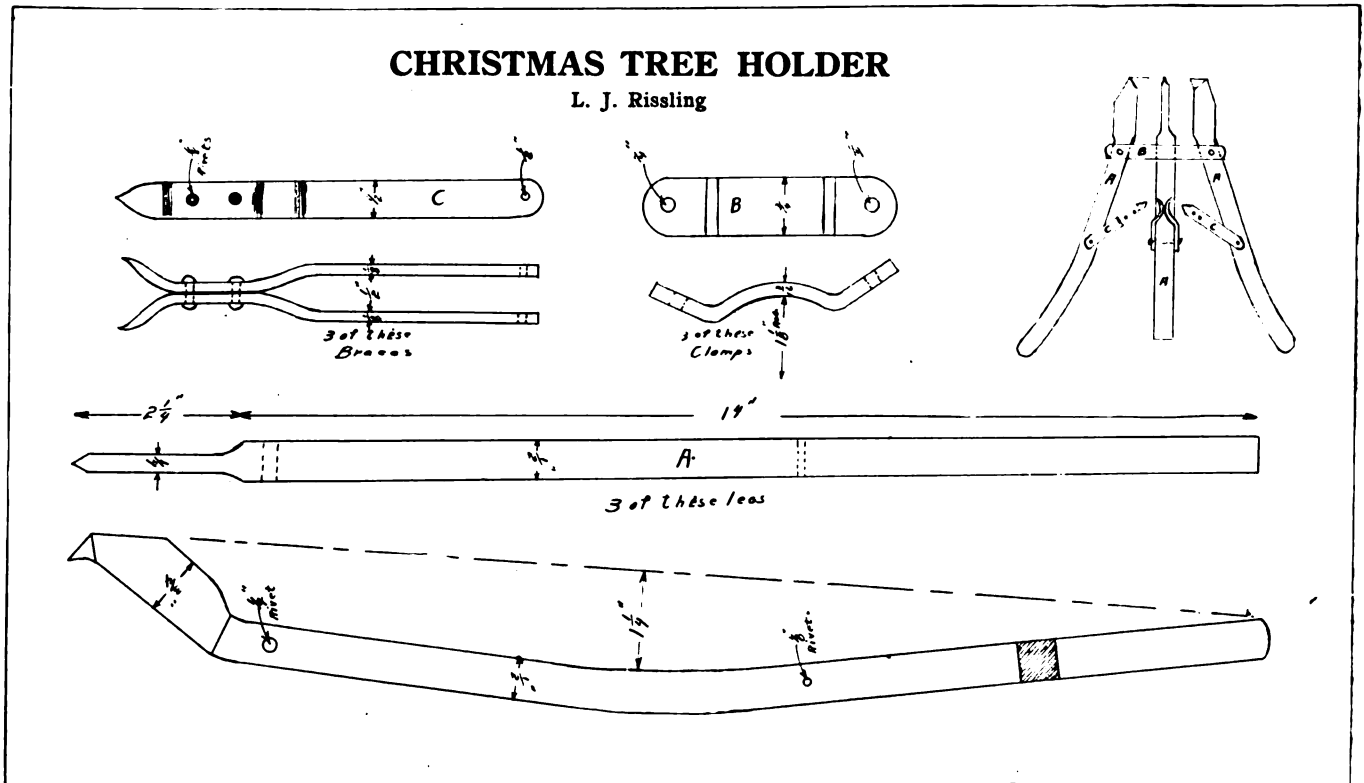

HARDLY a shop in the land but has been called on, at one time or another, to make a holder for a Christmas tree. A soap box with a hole through it will answer, under some conditions, if a man has the patience of Job to fix it this way and then, like as not, will be unsteady on its base as a man coming home after "sitting up with a sick friend."

The illustration of this holder makes construction simple. The dimensions can be altered to hold trees of various sizes although the holder is adjustable within certain limits.

The legs are made of $\frac{1}{2}$ inch square iron, flattened on one end to $\frac{3}{4} \times \frac{1}{4}$ inch. The point is bent and filed to shape as in the drawing. The clamps are made of $\frac{3}{4} \times 3-16$ inch iron and these may be made larger or smaller to suit. The one here shown will accommodate a tree having a stem about two inches in diameter. The braces are made of $\frac{1}{2} \times \frac{1}{8}$ inch iron and serve to hold the tree upright and are pressed down from above as shown in the sketch, at the right.

The holder may be put together with stove bolts or rivets and the whole finished off with a coat of green or gold paint.

A file may be kept from filing up with lead by applying a coat of thin oil just before filing.

THINGS TO DO TO PREVENT FIRES

Don't throw away lighted matches, cigars or cigarettes.

Don't use kerosene, benzine, or nophtha in lighting fires, or to quicken a slow fire—it may result in death.

Don't use gasoline or benzine to cleanse clothing near an open flame, light or fire.

Don't use wooden lockers.

Don't permit oily rags to lie around.

Don't use an open light when looking for escaping gas or in the presence of inflammable liquids.

Don't use sawdust in spittons or to absorb oils.

Don't let the fact that you are insured make you careless.

Don't put ashes in other than metal receptacles, and don't dump them where they will come in contact with combustible materials.

Don't hang electric light cords on nails.



BE SAFE—BE SOBER AND BE HAPPY

How I Built My Own Power Hammer

Otto A. Wagner.

ONE of the most important parts of the hammer is the device for producing the elastic stroke and cushioning the blow. I used the bow spring made of 1½x5-16 inch spring steel, this spring should have six or seven leaves, the outer leaf should conform to a 20" circle when released, that is, it appears like the half of a hoop. The ends of the outer leaf has hooks bent on them to form bearing places the spring links already described. The other leaves are made shorter than the one underneath it and fit into each other with a little spring or set. In fact, the same principles that apply to the making of this spring applies to the making of all auto and carriage springs. Enough extra metal should be allowed for on the ends of the longest leaf to make the hooks. The centers of these hooks should come on a line with the same line that cuts the circle in half.

At D in Fig. 3 (See November number) is shown the lower half of the connecting rod which is a built up forging. This was made by taking a piece of heavy 1½ inch pipe. For the lower end, or foot, I took a piece of 1½ inch square stock, split the end and turned it apart and drove it back so as to form a tee, then cut it off leaving a stub about 1½ inch long. I drew this down round so that it would fit into the pipe into which it was driven and the two welded together, the foot later being shaped to fit the curve of the spring. The pipe was then cut off 6½ inches from the foot, allowing a little to butt up. A plug about 1½ inches long is driven into the upper end and an eccentric band, one that is thicker on one side than on the other, made of 1 inch square stock is driven on to the upper end of the pipe so that the heavy side is at one side in relation to the foot. The whole thing was welded up and the end shaped so as to form a boss for a clamping bolt such as are often used on the hubs of engine fly-

wheels. Then chuck this piece in the lathe and drill and bore the upper end to 1⅛ inches to receive the shank of the upper connecting rod. Turn the end true and shape the whole thing up with emery grinder and file. Then drill a 17-32 hole crosswise through the top end as shown in the dotted line. Of

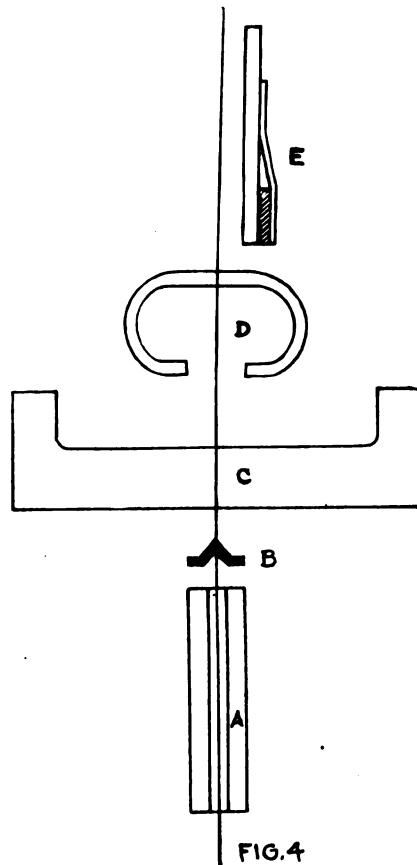

course this hole must be to one side of the head, through the thick side of the band. Then saw the head open for several inches down so as to allow the bolt to clamp it on to the shank of the upper rod. This bolt is ½ inch. This piece is fastened to the spring with two "U" bolts and a yoke plate having four holes drilled in the four corners to receive the ends of the bolts. The U bolts are made of ¾ rod.

The upper half of the connecting rod as shown at E in Fig. 3 I made of 1½ inch square stock. I drew it down to round for a way

and then cut it off, leaving about 5 inches of square. This I stoved down as in making a T head bolt and worked it in much the same manner considering the shape I desired when completed, finally bringing it to the shape shown in the sketch. This box end is about 2x4 inches on the face. The cap is made of the same stock and worked into the shape shown and is cut to the length of the head of the rod. Then I turned the shank to 1⅛ inch to fit into the lower half of the connecting rod already described. This must be a good sliding fit so as to permit of adjustment. I faced the end of the rod in the lathe and also faced off the cap in the same manner, provided the holes for the cap bolts which are ½ inch and bolted it to the rod and then chucked it in the lathe and bored out the opening for crank pin and this hole was made sufficiently large to allow for about ¼ inch of babbitt metal all around. The sides of the rod head were also faced off in the lathe. The width of this bearing is 1⅞ inches. I then tinned the inside of this box and babbitted it with auto babbitt having liners or shims between the halves to allow for take up. It was then placed in the lathe again and bored out to fit the crank pin. The connecting rod cap is drilled and tapped for an oil or grease cup.

Next to be considered is the guide construction. Figure 4 shows drawings of these parts. At A is shown one of the guide plates of which there are two. These are made of angle steel 2x3-13 inch and 12 inches long. I struck a line on each side of them one inch from the corner and along these lines I turned them apart at sharp angles as shown at B, thus forming a V for the ram to work on with feet or flanges for fastening to the other parts. These plates must be left straight and flat and the flat sides should be scraped and filed until true. The V's must be filed and scraped to a perfectly straight bearing. One of these plates is

riveted to the face formed by the angles in D in Fig. 1. It must be in line with the uprights of the frame. I used 5-16 inch rivets for this, placing five on each side. The remaining plate should have one end trimmed off round for appearance at the upper end. This plate is fastened to the guide bracket shown in sketches C and D in Fig. 4.

Take a bar of $3 \times \frac{5}{8}$ inch flat steel 22 inches long and weld to the ends

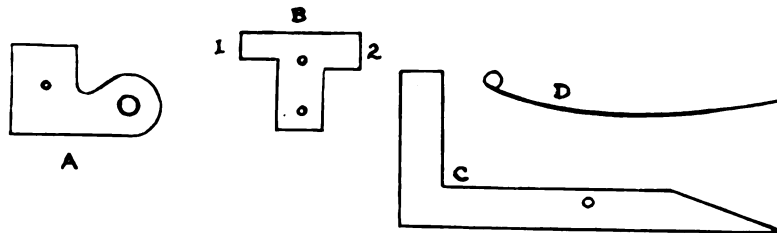

FIG. 6

two pieces of $1\frac{1}{2} \times \frac{5}{8}$ inch flat as shown at C. Cut them to 6 inch lengths and square the corners up good and then bend this bar so as to form a large C as shown in sketch D. The particular part about this is to have the ends just $3\frac{1}{8}$ inches apart, allowing a little for filing to true as these ends form the feet where the bracket is bolted to the frame. The back of the large C should be $4\frac{7}{8}$ inches from the faces of the feet and all should be left as square and flat and as nearly in line as possible.

Sketch E shows how the front guide plate is riveted on the inside of the bracket. As shown a brace made of 5-16x3 inch flat stock is riveted to the guide plate with two 5-16 inch rivets. The feet of the bracket D are each drilled and tapped for three $\frac{1}{2}$ inch cap screws and are bolted to the angles D in Fig 1 so that the feet set on each side of the guide plate that is riveted to them. As seen in the picture, this guide bracket must be set with its feet pointing up so the body of the bracket will be even with the bottom of the angles D in order to permit the spring links to move down with the ram without striking the guide bracket.

In locating and riveting the front guide plate onto the bracket D, too much care cannot be taken to have it in line with both ways with the guide plate on the frame. It must also be seen to in the construction of this guide bracket, etc., that there is allowance made for shims between the feet of the bracket and the angles D where they fasten, so as to allow for take up.

Oil these guides with heavy oil

and graphite, as steel to steel requires good lubrication.

One of the parts that took a good deal of work to build by hand was the tightener pulley frame and supports. In Fig. 5 the upper ends of the uprights of the frame are shown at A, the large circle B indicates the main pulley already described, the parts marked C are the tightener supports made of $1\frac{1}{4} \times \frac{1}{4}$ inch angle and bent as shown. A hole is drilled in the upper end to receive

a $\frac{5}{8}$ inch pin and this hole should be just level with the center of the crank shaft and, $6\frac{1}{2}$ inches from the center of the shaft. This pin forms the pivot for the tightener frame. There are two of these tightener supports bolted to the top angles of the frame as shown, one on each side of the pulley. For the tightener frame I made two parts, as shown at D. Fig. 5, the circle at the top indicates the tightener pulley which I made of two stacker raddle pulleys off of an old threshing machine. I put them on the shaft, flanges out forming a flanged pulley 5 inches in diameter and 5 inch face. The parts D, I forged from $\frac{5}{8} \times 2$ inch flat steel. The centers of the bosses are 15 inches apart. The tail at the bottom ends are for the brake blocks which are so arranged that they are applied to the flanges of the main pulley when the tightener swings back. The top bosses are made for a clamping bolt shown at the dotted line to clamp the bearing bushings with. The main bosses are drilled to $1\frac{1}{8}$ inch. A forging as shown at E is made of $\frac{3}{8} \times 2$ inch flat stock each end of which is 5 inches long from the center and has holes drilled as shown. The center hole is $1\frac{1}{8}$ inches, next is taken a piece of $1\frac{1}{4}$ inch shafting $8\frac{1}{4}$ inches long. This is chucked in the lathe and drilled through its center from end to end with an 11-16 inch drill, then turned down to $1\frac{1}{8}$ inch for a distance of $\frac{3}{8}$ inch on one end and 1 inch on the other. The long arms, D, D, are then driven on to this sleeve. The part E is also driven on to the long end and put in the position as shown at F, the

long arms then being lined up and all brazed fast to the sleeve H thus forming a solid forging. The centers are carefully located in the upper bosses so as to have them the same distance from center of hole. In sleeve H a block of wood is then placed between the arms to keep them from springing, a one inch drill is then chucked in the lathe and these holes are drilled between lathe centers to have them line up, these holes are for two bronze bushings which are 1 inch outside and $\frac{5}{8}$ inch inside. The holes for the clamping bolts are then drilled near the end of the boss and then the bosses are sawed open. These bolts are $\frac{3}{8}$ inch. Turn the idler shaft to fit the pulley in the center and to fit the bushing at the end. To assemble the pulley in the frame, place the pulley between the arms and then slip the shaft in the pulley and tighten up the set screws, then slip the bushings onto the shaft and into their holes in the arms and clamp them fast with the clamping bolts. The frame is then hung between the supports and the pin is slipped through them and a cotter inserted. The single hole in part E is for the operating rod, the three holes in the other end being for the spring to be hooked in that swings the idler back when the treadle is released.

Now comes the treadle construction. The pivots or spools that it are hinged on, I made from $1\frac{3}{4}$ inch shafting. I chucked this shaft in the lathe and drilled into the end to the depth of $2\frac{1}{2}$ inches with an 11-16 inch drill, then turned a tenon on the end $1\frac{1}{8}$ inches in diameter and $\frac{7}{8}$ inch long and cut off to $1\frac{3}{4}$ inches in length. There are two of these spools and they belong on the bolts at the rear end of the wooden base already described. Then out of material $\frac{5}{8} \times 2\frac{1}{2}$ inches I forged two eyes with shanks drawn out to $\frac{1}{2} \times 1\frac{1}{4}$ inches. The eye part has a $1\frac{1}{8}$ inch hole to fit the tenon on the spool just described. These eyes are riveted to the ends of the treadle proper and form the hinge for the same. The treadle is made of a piece of $1\frac{1}{2} \times 3-16$ inches angle 8 feet, 6 inches long and is bent as shown in the picture both sides being bent alike.

As seen in the picture there are two ears riveted to the treadle angle, one on each side, just opposite the back edge of the front uprights. In these ears are hooked two rods made of $\frac{5}{8}$ inch round,

with a piece of $1\frac{1}{4} \times \frac{3}{8}$ inch flat welded to the upper end. The measurements of these rods are best worked out after the rest of the machine is assembled, it will be noticed that the flats of these rods work on each side of the lower guide support bar. They have a spacing block bolted between them below the bar and between the upper ends is bolted a forging as shown at B in Fig. 6. The body of this forging is $\frac{3}{4} \times 1\frac{1}{4}$ inches with the two extending lugs 1 and 2. Lug 1 is $\frac{3}{4}$ inch round with a cotter pin hole near the end and receives the forging A. Lug 2 is $\frac{3}{4} \times 1$ inch and slides in the space between the two upright angles, forming a guide for the treadle reins and also forms an engaging lug for the locking bolt C fig. 6. This safety lock is something new in the power hammer line. It is forged as shown. The long leg is 16 inches long, the short one is $4\frac{1}{4}$ inches long. The long leg has a hole drilled through it, as shown which has a pin about 4 inches long driven through it to serve as a

and others. A study of the picture will explain this arrangement. The piece A Fig. 6 is made of $\frac{5}{8} \times 2\frac{1}{2}$ inch stock and is 4 inches long over all and shaped as shown. The hole in the rounded end is $\frac{3}{4}$ inch and works on the lug 1 on piece B. The hole in the large end is for a $\frac{3}{8}$ inch bolt.

The dotted lines indicate a recess $1\frac{1}{4}$ inch wide and $\frac{1}{4}$ inch deep made in the forging to receive the lower end of the bar which connects the lever on the tightener frame with the treadle and transmits motion from the treadle to the belt tightener. This bar is made of $1\frac{1}{4} \times 1\frac{1}{4}$ inch flat stock. The upper end has a round pin forged and bent on it to fit in the hole in the lever on the belt tightener frame that shown at F in Fig. 5. The lower end of this connecting bar has a slotted hole to allow for adjustment. The length of this bar had better be made to suit the rest of the machine after it is assembled. It will need some kinks in it too, to accommodate it to the rest of the parts. A hook is made and fasten-

The dies for the anvil and ram must be made of tool steel. 2×3 inches is the right size, they must have dovetails formed on them to fit the dovetail slots in the anvil and ram. I formed them roughly by the use of a set hammer with the help of a sledge in the hands of a helper, then finished them by grinding and filing. Here, as in many other places, a planer would be much better. Allowance must be made in the fit of these dovetails for a tapered wedge or key. There must also be a dowel pin in the bottom of these dies to keep them from working. The faces of these dies should be shaped to suit the kind of work to be done. If a great variety of work is to be done several different pairs of dies will be necessary, however, most blacksmiths use a hammer only for plow work and general drawing and for this purpose what are called drawing dies are necessary. Such dies have rounded or curved faces the curve of the lower die should be slight so it will fit the concave side of a plow disc. The upper die should have more curve but the curve should not be too sharp, if you expect to turn off smooth work. I hardened my dies by heating in a clean fire to the hardening heat then applying to the face a paste composed of salt and flour mixed with water. Continue the heat a few minutes and then suspend the die with its face in cold water and let cool in that position and draw no temper.

The anvil of this hammer weighs 525 lbs. In changing the dimensions of the angles used as I have done in this article, it will be necessary to increase the length of the wooden bar about 1 inch over the figures I have given.

By a careful reading of this article and examination of the sketches and picture given, I believe any blacksmith will be able to build a machine similar to the one I have which performs very satisfactorily, the crank-shaft speed should be from 300 to 375 R. P. M.

In erecting or installing this hammer the counter shaft should be placed directly above the crank-shaft, the pulley should be a flanged pulley the same diameter as the one on the hammer, or as near as possible. Lace the belt loose enough so that it will glide around the pulley without dragging when the hammer is at rest.

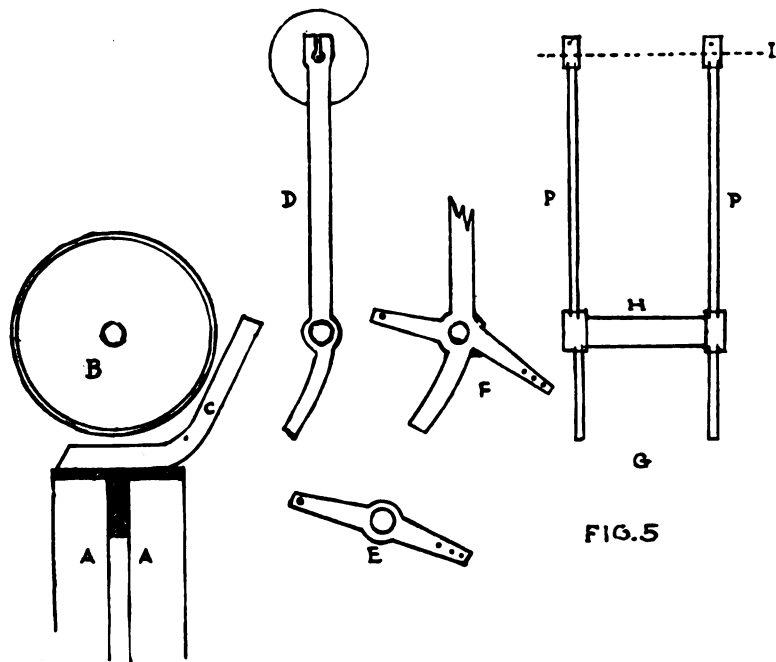

FIG. 5

handle to slide it with. This locking bolt slides in the spaces between the upright angles of the frame A Fig. 1 and the angles D Fig. 1. A flat spring shown at D Fig. 6, is bolted between the said angles so that the center rests on the locking bolt and serves as a friction spring. When this locking bar is pushed back the upper end of the short leg engages with the lug 2 on piece B Fig. 6, and locks the treadle so the hammer cannot be operated thus avoiding accidents to children

ed with the same bolt that fastens the lower end of the connecting bar with piece A Fig. 6. One end of a coil spring is hooked on this and the other is hooked in one of the holes on the three holed lever on the tightener frame shown at F Fig. 5. This spring serves to raise the treadle and swing the belt tightener back applying the brakes to the pulley and stopping the machine quickly, this spring must be just strong enough to perform it's duty right.

Tearing Down Repairing and Assembling Automobile Starting and Lighting Batteries

Part 3

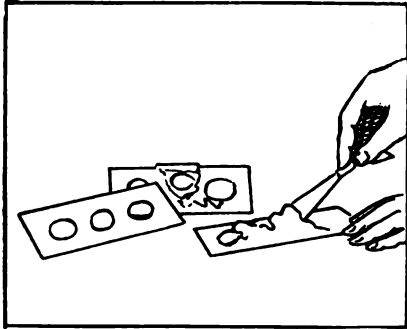

33—After heating the putty knife, clean all the compound off the covers.

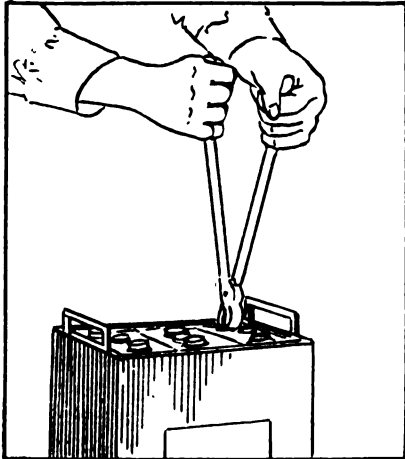

34—Sometimes the bottom cover will not fit properly over the element. By using a pair of pliers in the manner illustrated, it will be an easy matter to locate the centers.

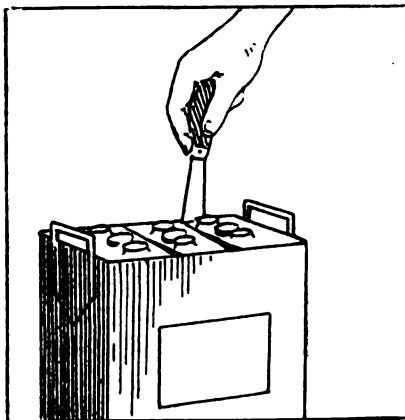

35—If the bottom cover does not fit close to the terminal posts, of the wall of the jar, the openings should be calked with hemp twine or tow to prevent the melted sealing compound from flowing into the jar.

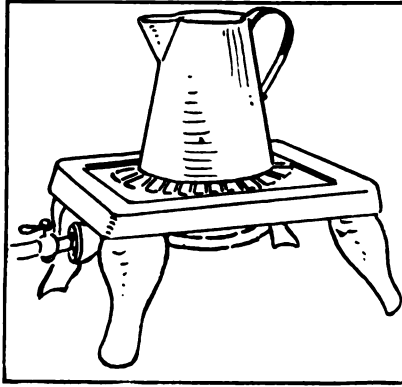

36—Small gas stove and ordinary coffee pot used for melting and pouring sealing compound.

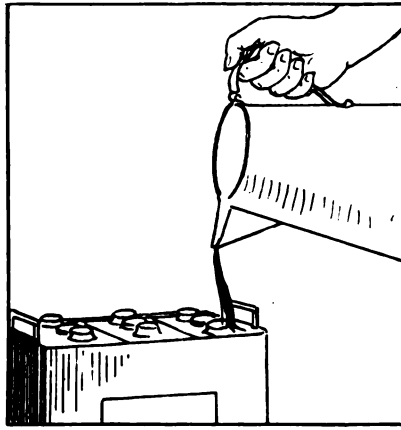

37—Always pour the compound so that it will fill all spaces and reach to a height level with the top of the case. Also see that it flows evenly over the whole surface.

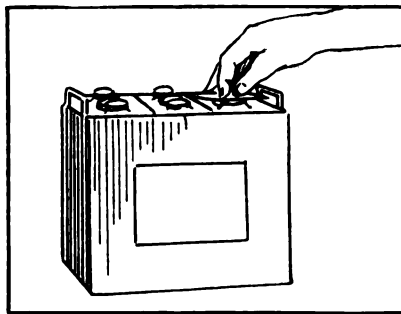

38—Before putting on the top cover, slightly heat it with a gas flame. Also heat the surface of the compound.

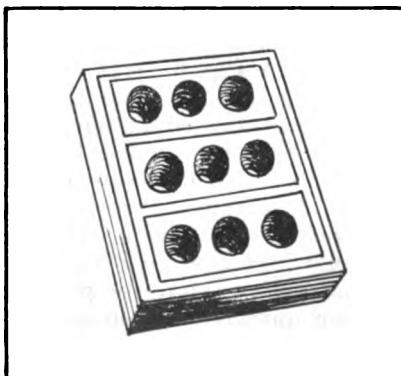

39—Wooden form used for properly holding the covers down while the compound is cooling.

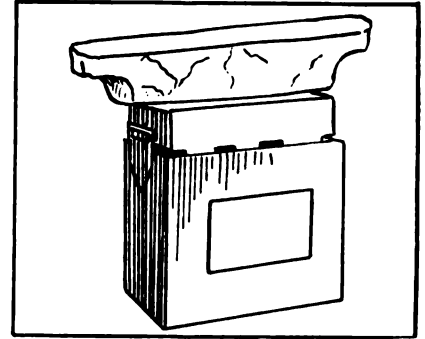

40—Place the wooden form over the covers and place a heavy weight on top of the form. The battery should stand for ten or fifteen minutes until the sealing compound has cooled and set. This can be scraped off with hot putty knife.

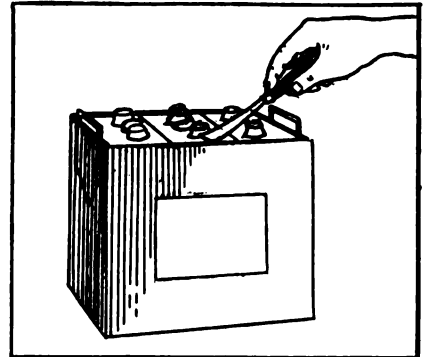

41—After the form is removed, there is always an excess of sealing compound.

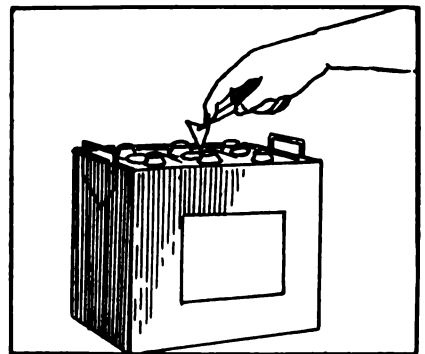

42—Before applying terminals see that the terminal posts are scraped clean of all compound and

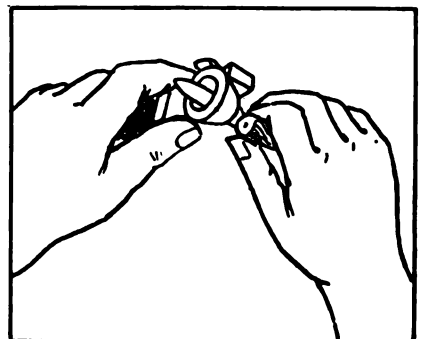

dirt. It is practically impossible to do a good job of burning if all parts are not properly cleaned.

43—Using an ordinary pocket knife, clean the inside of the connectors, removing all dirt and oxides.

Clean the tops of the connectors with a rasp file to remove dirt and oxide.

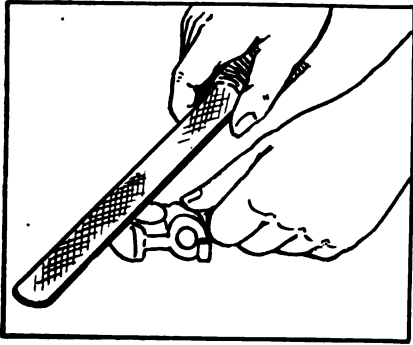

44—Before applying the terminal connectors test all cells with a voltmeter to see if they are set properly. If a voltmeter is not handy, scrape the rubber bushings on each side of the post. The red bushing is positive and the black is negative. The connectors should be applied so that the positive of one cell is connected to the negative of the next cell.

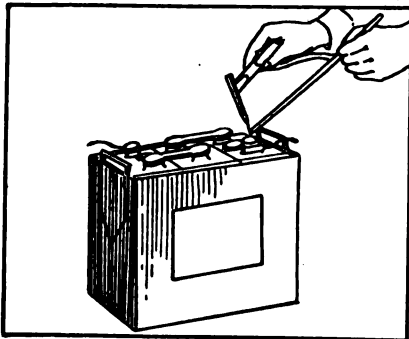

45—In “burning” connectors and terminals to the posts, melt the top of the post, then the edges of the hole in the connector. Melt strips of antimonious lead and allow the molten metal to run into the hole in the connector. Care must be taken to see that the top of post and inside edges of the connector are melted together before applying additional lead. If this is not done the connection will surely pull loose. Care should also be taken not to melt the outer edges of the connector. Practice will be found necessary.

46—After burning the connectors and terminals, mark the positive terminal with a stamp “POS”

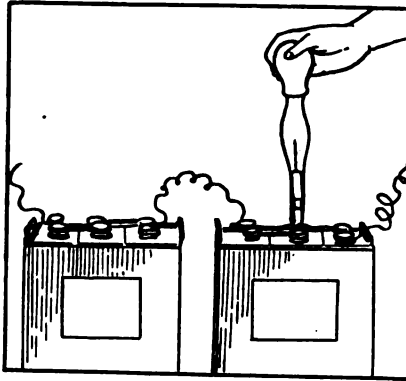

and the negative “NEG”. If a stamp is not available, use a blunt instrument and mark the positive (x) and the negative (-).

For data concerning the strength of electrolyte to be used see article Electrolyte in a previous installment.

CHARGING

When the battery is filled with electrolyte, it will heat up and should not be put on charge till the electrolyte has cooled which will take from six to twelve hours.

Start the charge at one half the normal charging rate and continue until the gravity of each cell has remained stationary for five hours. During the development charge take occasional temperature readings and if the temperature of any cell exceeds 100 degrees, lower the charging rate, or discontinue the charge until the cell has cooled.

If the battery has new plates, 60 hours will be required for the development charge. If the plates are old and badly sulphated more time may be required.

Any cells which have not been torn down for repairs should be left out of the circuit during the first thirty hours of the developing charge. They may then be connected into the circuit and the whole battery brought to full charge.

When the charge is complete, adjust the gravity of the electrolyte to 1280 to 1300. To do this remove some electrolyte from the cell and replace with pure water until the desired gravity is reached; or remove electrolyte from the cell and replace with 1400 degree acid solution, according to whether the cell is reading high or low.

Clean off the top and sides of battery with a cloth soaked in a weak solution of ammonia, cover terminals and connectors with a coating of vaseline to prevent corrosion and the battery is ready to be put in service.

FARMER BECOMING MOTORIZED

We are not speaking of futures when discussing motor transportation for the farm—it has already arrived! Forty per cent of the motor cars in America are owned and operated by the farmer. There are three times as many automobiles in Iowa and Nebraska, both big agricultural communities, in proportion to the population, as there are in the states of New York, Massachusetts or Pennsylvania.

Manufacturers’ reports show that the big increase in sales of passenger cars and trucks in recent years has come from agricultural rather than from manufacturing states.

And with this increased usage comes the education of the farmer as to the real possibilities and value of motor transportation. Shortly, for the modern farmer, the problem will narrow itself only to the choice of car or truck; the utility and value of motorizing the farm industry will be definitely and firmly established.

The characteristic farsightedness of the American farmer will bring this about when he realizes that one two-ton truck on his farm will release at least four horses; that one horse requires five acres of tillable land to support it, land which should be raising the valuable foodstuffs required for human consumption.

By the use of motor trucks, farmers can haul to market while keeping their horses working in the fields. In this way, land formerly too far from market for profitable farming is brought into good use.

The farmer is also coming to be the large passenger car owner. The motor car is not only increasing his working capacity and the happiness of his family; it is keeping his boys on the farm.

TIGHTENING WRIST PIN BUSHINGS

To tighten a loose wrist pin bushing when it is located in the connecting rod, take a piece of tubing that will just slip over the bushing on one side of the connecting rod. Next get a piece of metal a little smaller than the bushing to put against it. Put these in a vise and press the bushing out. Now give the bushing about a quarter turn and thrust it back in the connecting rod and you will find the piston pin tight enough to run for some time before it will be necessary to renew the bushings.

Legal Considerations Having to do With the Sale of Used Automobiles*

ELTON J. BLACKLEY

I AM IMPRESSED with the enormous increase in the business in used automobiles—both pleasure cars and business wagons—and the extent to which high-grade and reputable business houses are buying used cars instead of new ones. All over the United States concerns are establishing themselves in the used car business, and as they are sure to attract more and more customers from among business people, I believe it will be useful if I say something about the methods some of these concerns use in order to avoid their legal responsibility.

The sale of a used automobile is a risky proceeding. A used car may be all right one minute and all wrong the next. In the hands of the wrong driver it may go wrong from the start. I am told that it is almost impossible even for an expert to tell to a certainty what the condition of a used car is, and how long it will stand up.

Nobody recognizes this risk more than the second-hand dealer, and this explains the earnest way some of them scheme to sell a used car with a guarantee that won't bind them.

There are undoubtedly some honest dealers in used cars, but my observation is that most of them are decidedly open to suspicion. In the hope that I may be able to forewarn the readers hereof how to deal safely with these concerns, I am writing this article.

A favorite and simple ruse adopted by almost all is to extravagantly guarantee and represent a car, and then give the purchaser a receipt, on which is printed in very small letters: "This car not guaranteed in any way, except to be in running order when it leaves our store." The purchaser should read every word on his receipt and if he finds anything like this on it he should not accept it.

By far the most elaborate scheme to defraud in the sale of used cars that I have seen has recently been tested in one of the Pennsylvania Appeal Courts. The attitude which the court took toward it would undoubtedly be taken by any court anywhere.

The dealer whose scheme this was is named Samuel Gorson, and he has one of the largest places in the East.

He agreed to sell a customer for \$875, a car which he guaranteed to be a 1914 Paige, "in good condition and guaranteed for one year." The customer paid \$325 cash, traded in an old Packard for \$225, and agreed to pay the balance in installments. He paid the \$325, turned over the Packard, signed the usual lease for the installments and took the car away. In the first two weeks it developed all sorts of trouble, and investigation proved it to be a 1913 car in very bad shape. The victim, after getting no satisfaction from Gorson, began suit for damages and the lower court gave him \$495. Gorson appealed and the higher court affirmed the lower. Both courts characterized the scheme which Gorson had used to sell this car as "a cunning fraud."

The scheme was this: After Gorson got the \$325 and the Packard car, he told his customer, "You go down to Tenth and Chestnut street; that is our big bookkeeping department and you pay the balance there." The customer was told that they didn't have room to do the bookkeeping in the room where they kept the cars, so he went down to Tenth and Chestnut, and signed some papers without paying much attention. When he brought suit, however, these papers were much in evidence. Gorson pleaded that he hadn't sold the car at all; that it had been sold by the "Auto Transit Co.," of whom the customer had leased it. The papers he signed were in the name of the Auto Transit Co., of which concern he knew nothing, and Gorson didn't appear in them at all. How this looked to the court is shown by the following extract from the decision:—

When the plaintiff went to Tenth and Chestnut streets, where Gorson, the defendant, directed him to go, a paper in the form of a lease was prepared which recited that the plaintiff had turned over a second-hand Packard car for \$225 to the Auto Transit Co., and that he had paid to that company \$325 in cash. He was also given a receipt book where the receipts for the installments to be paid on the balance of the purchase money were to be entered. This book was opened in the name of Gorson. The lease given to the plaintiff contained the following clause: "This car is positively not guaranteed by this company. This agreement constitutes the entire contract between both parties." It was developed by the evidence that the Auto Transit Co. received a commission of 10 per cent. for transacting this business for Gorson and that the plaintiff testified that the defendant had stated to him that the Auto Transit Co. was his agent. It is quite evident from the facts disclosed that the connection between Gorson and the Auto Transit Co. in the transaction was only

intended to shift responsibility for his guarantee or the misrepresentation of his agents from his shoulders. There is scarcely a denial of the fact that the sale of the automobiles was made directly to the plaintiff at the defendant's place of business, and that about three-fifths of the purchase money was then paid as a result of which he acquired title to the property subject to the right of the vendor to retain possession to secure the deferred payment. Gorson had no right thereafter to sell the car to the Auto Transit Co. or by the device resorted to to deprive plaintiff of the title which he had acquired and the evidence was sufficient to warrant the trial judge in holding that the Auto Transit Co. was the agent merely of Gorson. The representation of that company in the lease given to the plaintiff that they owned the automobile and that he had made a payment to them on the purchase price was concededly untrue, and the transaction was a thinly veiled attempt to deprive him of whatever right he had acquired by the purchase from the defendant.

Besides this, Gorson raised several other defenses, not one of which, as appears in the report of the case, was the straightforward defense that the car was what he said it was.

Sometime ago a business client of mine decided to buy a used truck from a second-hand dealer, and consulted me as to how to obtain proper protection. I gave him a form of guarantee which he put in his pocket and then went up to the second-hand dealer. The latter made several specific representations about the truck, which were satisfactory to the prospective buyer, and the latter then requested him to put them in the written form which I had prepared, and which read as follows:—

Date
I, the undersigned, covenant and represent that I am the owner of a certain or if not the owner, that I have authority to sell same upon the terms set forth below. That said was manufactured and sold during the year and is Model No.; that same has not been used in excess of miles, has been carefully and thoroughly examined by competent mechanics, and has been put in good mechanical condition wherever repairs were needed. I hereby warrant said to be in perfect mechanical condition throughout; except in the following respects:.....
.....
I acknowledge that I have this day sold the said to upon the above representations
Witnesses:
and warranties, for the sum of \$.....
.....
.....

Although the dealer said verbally everything contained in the above, he refused to put it in writing on the ground that "his word was as good as his bond."

Queries-Answers-Notes



THIS department is the meeting place where you are free to ask for information, answer questions, discuss shop matters and business conditions and any other notes you feel would be of interest to a fellow mechanic. Make use of this Department as often as desired.

Finding Pulley Speeds—Will you please include in some future number particulars on how to calculate the speed of pulleys, as we have some shafting to put up to drive agricultural machines.

B. Thomas & Sons, England.

Fortunately calculating pulley speeds is a rather simple matter and that no one should have difficulty in understanding.

It is well known that the smaller of two gears or pulleys will always run faster than the larger. Thus, if the driver is of larger diameter than the driven pulley, the driven pulley will run faster than the driver; but if the driven pulley is the smaller of the two, it will run faster than the driven pulley. The product of the diameter of the driver and its number of r. p. m. is equal to the product of the diameter of the driven and its number of r. p. m., in the case of pulleys; in the case of gears, the product of the number of r. p. m. From this it will be seen that it is easy to find the size of one pulley when its speed and the speed and size of the other pulley are known, or, to find the speed of one pulley when its size and the speed and size of the other pulley are known. The rule to be used is as follows:

To find the diameter (or number of revolutions per minute) of one pulley, multiply together the diameter and the number of r. p. m. of the other pulley and divide the product by the number of r. p. m. (or the diameter) of the first pulley.

This rule may be used to find the number of teeth or the number of r. p. m. of one of two gears, by using the number of teeth instead of the diameter of each pulley. The speeds of wheels, pulleys and gears are usually expressed in revolutions per minute, which is abbreviated r. p. m.

As an example, two pulleys are 36 inches and 12 inches in diameter, respectively and the larger pulley makes 120 r. p. m. How many r. p. m. does the smaller make? Multiplying 36 and 120 (the pulley diameters) together gives a product of 4320. Dividing this product by 12 gives 120 or the number of r. p. m. made by the smaller.

To ascertain the speed of pulleys where the speeds of both pulleys are known but only the diameter of one is known as in the following: A pulley 54 inches in diameter runs at a speed of 100 r. p. m. and drives another pulley at a speed of 450 r. p. m. What is the diameter of the other pulley?

The solution to this is to multiply 54 and 100 together and divide the product by 450, thus will be found that the diameter of the pulley is 12 inches.

J. S. H., New York.

From "Mack" The Blacksmith.—I have been blacksmithing for 22 years and am now going to take up auto and tractor

work. The Auto & Tractor Shop is the best publication in this line of work that I have ever seen.

R. R. McPherson, Colorado.

Read This—I have received several copies of your magazine which have been sent me and I found them of interest and value to me although I am not a blacksmith or at work in any form of the trade, but am located on a farm and have in my charge a Buick car and your magazine is a great aid to me in understanding its mechanism. I also find many other articles of aid to the handy man on the farm who is willing to learn how to do his work correctly.

Merrill W. Korber, New York.

A Colored Man With An Idea—In one of the large Missouri cities, H. E. Clark, a colored man who has had extended automobile experience decided to strike out on his own and on thoroughly original lines.

He leased a plot of ground on one of the main thoroughfares and built covered pits and an office and operates an oiling station.

Clark charges \$1.50 to go over the car and take the squeaks out of it. He charges \$2.25 for filling crankcase, universal and transmission, the cost of the lubricants being figured in addition to the time. He handles from 15 to 20 cars a day and his unique establishment has proven to be a welcome innovation to those drivers and car owners who are not mechanically inclined or have not the time to devote to this important matter.

Re magnetizing Ford Magnets—The usual and proper method to remedy weak magnets is to replace them with new ones. The Ford Co., do not advise everyone to

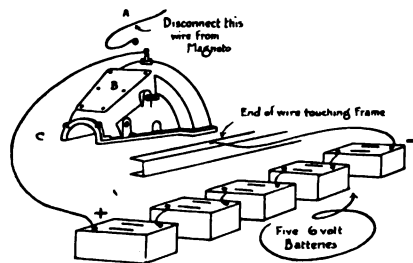

attempt this work. This, however, necessitates taking down the engine and is a big job. Therefore, different methods are used to recharge magnets without removing them from the car.

Charging with Storage Batteries: Five or six 6 volt storage batteries should be about right and is possibly the simplest method of doing the work.

To prepare the magneto for recharging, first disconnect the wire A which goes from the magneto terminal on the transmission cover to the coil on the dash.

Next remove the transmission cover plate B so you can look at the magneto. Locate the brass studs on the rim of the flywheel which holds the magnets in place and then have someone turn the engine over very slowly until one of these brass studs is in line with an imaginary line drawn about one inch or so from the magneto terminal, to the left of the latter and paralleling the frame. Another way is to place an ordinary small compass on the transmission cover about one inch from and to the left of the magneto terminal, at the same time turning the engine slowly until the needle of the instrument is parallel with the engine.

The north pole end of the needle should point towards the engine when in this position.

Connections: Connect a wire from the POSITIVE terminal of the battery to the magneto terminal on the engine as shown at C.

Next connect a wire from the negative terminal on the battery and make and break the circuit by striking the free end of the wire on some metal part of the engine.

Permanent connections SHOULD NOT be made, but only 30 or so momentary contacts, which will recharge the magnets much more satisfactorily than if a permanent contact is made.

Dry cells can be used if necessary. Use 48 connected in series multiple. Connect positive or carbon poles with terminal.

110 volt Direct Current can be used but it will be necessary to use a resistance lamp bank, using 28 thirty two c. p. carbon filament lamps. Connect positive pole with magneto terminal. The lamp bank should be connected so as to deliver about 27½ volts.

Oxygen Generators—Can you give me any information about generating oxygen gas for welding? I would like to make my own oxygen if I could make some sort of apparatus for the purpose. Would such a generator give good results?

H. S. Jeffries, Renna.

In Reply—Oxygen gas is manufactured from chlorate of potash and manganese dioxide, mixed together and heated in a retort. Present prices for both of these materials make the manufacture of gas by this process out of the question. Also it is rather a risky matter to evolve oxygen gas by this means as any organic matter mixed with the chemicals in the retort would cause an explosion. This foreign matter may be a substance that would retain sufficient heat to create a spark.

The oxygen on the market today is obtained either by the electrolytic process, which is based on the well known principle of decomposing water electrically into its constituent elements of oxygen and hydrogen, or the air process, which consists of separating the different gases by extremely high pressures. The oxygen is then compressed in steel containers and may be considered absolutely safe. The user is cautioned not to use oil in any form on the tank or regulator valves where it will come into contact with the oxygen under high pressure.

The welding business has suffered considerably on account of the explosions in this type of generator. To a certain extent, the same is true of the acetylene generator, although a well designed acetylene generator can be considered as being safe if properly handled, but the question of proper handling is serious enough to

cause the use of any form of generator only one of absolute necessity when compressed gases are not obtainable.

It is almost impossible to cause an explosion with any kind of apparatus where compressed gases are used and investigations that have followed explosions have resulted in the conclusion that the purity was questionable, rather than the fault of the apparatus.

Generation of your own oxygen, we feel would be out of the question; expensive and decidedly unsafe. In fact it would pay you to forget it.

J. S. H., New York.

Eating His Head Off—United States statistics compiled in reference to horse hauling show that the average farm horse actually works but three and one-half hours a day. He consumes ten pounds of food for every hour of work, or 12,000 pounds a year, which is the product of 5 acres under cultivation. Thomas Edison says, "A horse is the poorest motor ever built. If he were of steel like a gas engine, he needn't be any larger than a soap box, but being a hay motor, and hay being exceedingly wasteful fuel, he had to be made enormously large in proportion to his power."

Finding Length of Belt—Can you or any of your readers tell me how to find the length of belts for power purposes.

A. C. Hamp, Texas.

Replying to the above—Multiply the distance between centers by 2 and add one half of the combined circumferences of the pulleys. For example we will say that the distance between centers of the pulleys is 25 feet which, multiplied by 2 will give 50. The circumference of the large pulley, we will say is 12.56 feet and the circumference of the smaller one is 9.44 feet and the combined circumference will be 22.00 feet. One half of the combined circumferences would thus be 11 feet. Add this 11 feet to the distance between centers that we multiplied by 2 or 50 and you will get the length of the belt, or 61 feet.

W. C. F., New York.

Welding Rod for Malleable Iron—We have an oxyacetylene outfit and do a large business in this line. We would like to know what is the best material to be used as filler for welding malleable iron. We have used Tobin Bronze with good results but it is expensive. Can you tell us whether there is any cheaper filler rod that we can use?

Ginther Bros., Mississippi.

In Reply—Either Tobin bronze or manganese bronze filler may be used for welding malleable iron. There is very little choice between the two as to price so that you will either have to give up welding malleable iron or use high price filler rod—until prices come down at least.

F. W. M., Illinois.

Installing Ford Magnets—What is the simplest way to tell the north from the south poles on Ford magneto magnets and what is the correct way to install them on the flywheel?

G. C. Noller, Mass.

In Reply—Ford magnets should be placed on the flywheel in the same order that they are shipped in the box. The ends of the magnets are also marked at the factory so that if the magnets do get mixed, one can still tell how they should be arranged on the flywheel.

However it has been the experience of some that the marker at the factory sometimes makes a mistake, so that it is safer to check up the polarity of each magnet before installing it on the flywheel. When the north pole of one magnet is brought near the north pole of another magnet, no attraction but rather a slight repulsion is exerted. But the north pole of one magnet will attract the south pole of another magnet very strongly. Briefly stated, like poles repel each other, while unlike poles attract.

These magnets should be placed on the flywheel, so that like poles are together. Thus, two north poles should be together under one clamping screw, then two south poles, then two north poles, and so on, around the circumference of the flywheel. By placing two of the same kind of poles together under each clamping screw, the result is a magnetic pole of twice the strength. But if unlike poles are placed together they will neutralize each other and the magneto will not give its full voltage. Since there are 16 magnets, one reversed magnet will cut down the strength of the Ford magneto about one eighth. If the magneto gives 8 volts at the lowest motor speed, 18 volts at normal speed and 30 volts when the motor is raced, one may be sure the magneto is in good order and that the magnets have all been correctly installed.

To tell which is the north pole of the magnet, either suspend the magnet on a light thread, so that the north pole can swing toward the north, or else test the magnets with a pocket compass and then the north pole of the magnet will repel the north pole of the compass.

S. S., New York.

Concrete Engine Base—Can you tell me in an early number how to build a concrete base for a gas engine or farm electric light plant?

P. Sibole, Kansas.

We will endeavor to include this information in our January number.

Editor.

Tire Filler As Insulation—Sometimes a wire whose insulation has become so worn as to expose the bare wire cannot easily be wrapped with tape. In such cases I have found that by taking a small quantity of good tire filler, such as used for filling tread cuts and working it into and around the chafed wire that it makes a very good insulation after it has set.

I have made several good repairs in this way where double contact lamps are used and the wires fit close together in the socket as in the Ford lamp. By pressing the filler around the wires and then screwing the cap on a very good repair is made. The wires are held firm so they do not vibrate and are thoroughly insulated in addition.

J. K. Pierce, Wyoming.

Clogged Radiator—What can I use to clean a radiator? I have used kerosene and it does not do the trick and the radiator is becoming clogged with rust.

J. Fisher, Canada.

The Simplest and probably the most efficacious treatment would be a mixture of a half pound of lye dissolved in a bucket of warm water. Stir well and strain the solution. Fill the radiator with this mixture and run the engine for five or ten minutes and allow to stand for about a half an hour. Draw off this solution and flush out the radiator, preferably with rain water or soft water and run the engine as before and repeat this again. This treatment should clean out the coils of a radiator pretty thoroughly. The lye does no harm and if one treatment does not suffice it can be tried until results are obtained.

There are various compounds for this purpose on the market but the treatment suggested will be found to give perfectly satisfactory results in most cases.

C. L. White, N. Y.

An Old Friend Passes—With much sorrow we learn of the death of J. Harvey Hanford, which occurred recently at his home in Orange County, New York.

Many of our readers will recall the interesting articles and observations that were the contribution of Mr. Hanford.

Mr. Hanford was one of the men that the mind instinctively pictures to accompany the term "blacksmith". He was one of generations of blacksmiths, the shop buildings and knowledge of the business having been passed on from father to son, who thus inherited traditions and love for his work that only too few possess.

While it is not our privilege to be personally acquainted with all of our readers, Mr. Hanford was one of the few that we have personally met and admired for those kindly and generous qualities that distinguished him as a friend, and a conscientious Christian.

Mixing Plaster-of-Paris—Almost every one has to mix up gypsum or plaster-of-Paris once in a while, but few know how to do it so as to make a smooth cream, or thin dough, without lumps. The trick is not to pour the water on the plaster, but to turn the latter gradually into the water, spreading it about in shaking it in, and to avoid stirring until all the plaster has been added. The proper quantity of gypsum is usually enough to peep out over the surface of the water over the greater part of the area; that is, about equal volumes of each ingredient. The addition of glue-water to the mixture retards setting.

ELMER BELL

Automobile Accessories, Farm Implements and Supplies

Blacksmith Shop and Garage

A little illustration entitled "Showing the Missourians". The Blacksmith shop happily wedded to the garage, accessory, supply and farm implement business—a combination hard to beat.

AMERICAN BLACKSMITH AUTO & TRACTOR SHOP

VOLUME 18

JANUARY, 1919

NUMBER 4

BUFFALO, N. Y., U. S. A.

Established 1901. Published Monthly at the Sidway Building, Buffalo, N. Y., by the

AMERICAN BLACKSMITH COMPANY

Incorporated under New York State Laws.

WILLIAM F. WENDT, President.

WALTER O. BERNHARDT, Editor.

SUBSCRIPTION PRICE:

For \$1.00 per year, payable in advance, The American Blacksmith, Auto & Tractor Shop will be sent, postage prepaid to any postoffice in the United States. To Canada, \$1.25; to other countries, 6 shillings. Reduced rates to clubs of five or more on application.

Remittances may be made by money order, express order or checks payable to the American Blacksmith Company. We will also accept uncancelled postage stamps or currency, but for safety these should be sent by registered mail.

Subscribers should notify us at once of non-receipt of paper or change of address. In latter case, give both old and new address.

Correspondence on all smithing subjects solicited. Always give name and address, which will be omitted in publishing, if desired. Address all communications to the

"AMERICAN BLACKSMITH COMPANY"

BUFFALO, N. Y.

"Copyright W. F. Wendt Publishing Company, 1918."

Cable Address: "Blacksmith, Buffalo"

FOR THE YEAR THAT IS PAST

Having already made our New Year's resolutions in the presence of witnesses we feel that a statement of our last year's achievements; a sort of recapitulation, so to speak, is in order.

One of the most important steps taken during the past year was the re-christening of the publication and the decision to broaden our field of usefulness with a larger treatment of the automobile and tractor, and at the same time have it retain its old time character and personal interest as well. In this we believe that we have succeeded admirably, and, that the change has been generally acceptable to our readers.

The past year has been one of difficulty and not without its dangers to publishers, on account of the many restrictions and the steadily advancing costs of labor and materials. Happily this period of high costs and the uncertainty of war's demands for the curtailment of materials is past, during which time the size of the paper has not been decreased nor the price increased. Some publications have seen fit to increase their prices to readers in certain postal zones, thus making the reader "pay the freight". This is another straw that we have been able to load on the camel with breaking his back.

We have been instrumental in bringing to the attention of our readers a number of articles on subjects that are not generally discussed, one of which we might mention as the articles on storage batteries. These articles have given the information that will make a thoroughly practical battery service man of any mechanic. That this information has filled a long felt want we are able to state from the large number of commendatory letters we have received.

We won't say that we publish the best paper in the world for then some other editor would call us a liar and then there

would be trouble but if there is any better publication for the practical man we haven't heard of it yet.

Our readers are called upon to give us the benefit of their ideas as to policy and methods for the coming year. We have our own ideas of course but we will accept yours with open minds, particularly if you will make any suggestion whereby we can improve our publication or make it more helpful, not only to you but to all of our readers.

There is nothing so pitiful as a man who believes that he knows it all—and admits it. Having a large number of readers with diversified interests it is considerable of a matter to understand just how we can best serve these interests, but with the loyal co-operation and kindly criticism of our readers behind us as they have been in the past the year 1919 will see the old Journal better and more interesting than it has ever been.

GOOD BYE GASOLINE

Another man has invented a substitute for "gas", this time an army officer, Cap't. E. C. Weisgerber.

How many times within the last few years have we been assailed by the news that someone has invented a substitute for gas! Then there have been all the variations such as increasing the extraction of gasoline from crude oil, extracting from oil shale, etc.

The gasoline consuming world has been disappointed so many times with reports of gasoline substitutes at lower cost than gasoline that another disappointment won't hurt much. However, one of these days someone will strike upon the solution to this problem and invent a satisfactory gasoline substitute that will be commercially practical and possibly Cap't. Weisgerber has found the solution. If he has, the gratitude of all motor users will be his.

CONTENTS—JANUARY 1919

| | |
|-------------------------------------|-----|
| Automobile Bearings | 81 |
| Micrographs | 83 |
| Steel Welding | 83 |
| Hupmobile Electric System | 85 |
| Removing Rim Rust..... | 86 |
| Tractor for the Small Farmer..... | 87 |
| Chilling and Casehardening..... | 88 |
| Overhauling the Car..... | 89 |
| Hardening Copper | 91 |
| Mixing Plaster of Paris..... | 91 |
| Working Aluminum | 91 |
| Steam Tight Joints | 91 |
| Waterproofing Leather | 91 |
| Removing Hard Grease, etc. | 91 |
| Lubricating Oil for Winter Use..... | 91 |
| Tubular Radiators and their Repair. | 94 |
| Helping the Crippled Soldier..... | 95 |
| Bringing the Trucks Back | 97 |
| Fuel Economizing Devices | 98 |
| Glossary of Storage Battery Terms. | 99 |
| Modern Cold Chisels | 100 |
| Ford Crank Case Supports..... | 100 |
| Payment of Forged Checks..... | 102 |
| Grinding H. S. Steel | 102 |

DON'T GIVE MONEY TO AGENTS

The American Blacksmith, Auto & Tractor Shop DOES NOT employ subscription agents. Any person representing himself as such is an impostor and should be so dealt with. Notify us immediately if anyone claiming to represent this journal calls upon you.

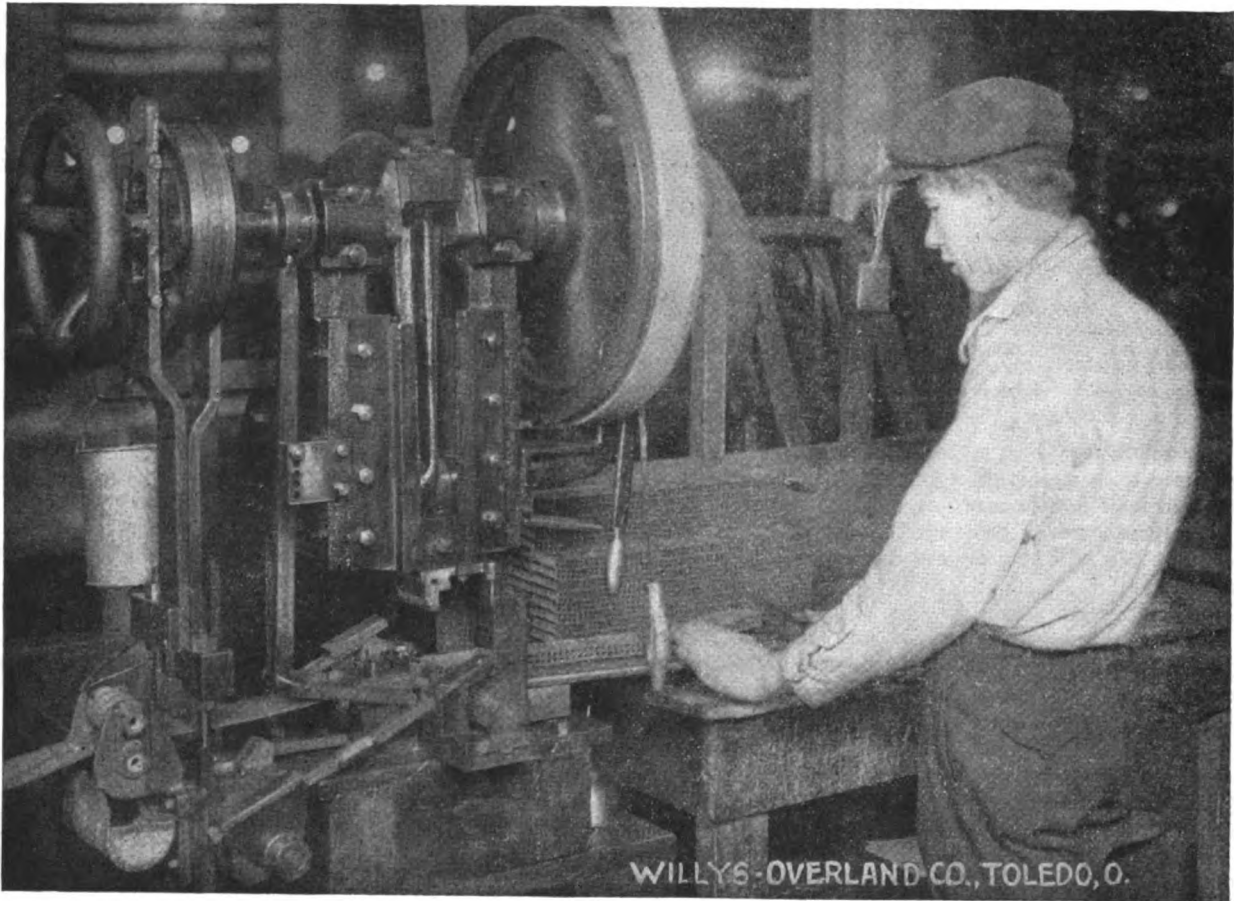

Machine that Automatically Forms Cellular Radiator Cores from Sheet Brass

WE once heard someone refer to a cellular or honeycomb radiator as "the thing on the front end of the car that looked like a bee's boarding house." Doubtless a lot of us have often wondered how the small cells were formed, whether by hand or machine and when one has had a "close up" look at a section of cellular radiator core, the wonder grew.

Through the courtesy of the Willys-Overland Co., we have the opportunity of giving a brief description of how the cells are formed. In the lower left hand corner of the illustration the brass ribbon is seen as it enters the machine. This ribbon is about three inches wide and comes in rolls from the mill.

By means of specially designed feeding apparatus and dies the cells are formed automatically on light punch presses. About the

only thing the operator has to do is to see that the ribbon is kept coming and to trim off the cells to the right length, with a pair of shears. He has nothing else to do but with one of these machines going at capacity he don't have a chance to do much of anything else except attend strictly to business.

Before being soldered together and made water tight the cells can be stretched apart something after the fashion of an accordion bellows. After a complete core has been assembled and soldered together, the top and bottom headers, overflow pipe, filler pipe and filler cap, water pipes, etc., are placed in the outside shell and secured. After passing numerous tests and inspections the completed radiator is sent to the assemblers in another part of the factory to appear again decorating the front of a Model 90 or a Willys-Knight.

Automobile Bearings—Their Operation, Care and Adjustment

Albert Marple

Naturally this article does not attempt to tell everything about automobile bearings but you will have a better understanding of this vital and quite generally neglected and abused portion of the car's anatomy

If you were to ask the average motorist what particular type of bearing any certain part of his car is equipped with he would gaze at you with a blank look and say something like "What do you mean—bearings?" Many motorists are aware that hidden somewhere within their very accomodating pile of mechanism known as the automobile are some things generally called bearings, but what they are and what they look like—what their work is and how to care for them is beyond their reach. Some folks say, "We don't have to learn about those things—the garage man takes care of them." If the motorist has an inexhaustible supply of coin he may be able to put this over, as they say.

Anyone who knows anything at all about an automobile will acknowledge that of all the minor mechanical parts of the automobile the bearings are about the most hard-working and, as a general thing, most efficient. And at the same time there is no other part of the automobile that is so generally abused. They stand a remarkable amount of abuse—conscious and otherwise. However, there is hardly a car owner in the country who realizes, if only in a limited way, the value of the bearings who will intentionally abuse them and when they burn out through lack of oil or the like it is generally through sins of omission rather than commission. Unless the bearing is given proper and constant care it cannot reasonably be expected to

do its work properly. If it is permitted to run dry or nearly so it is bound to work hard and the chances are that it will be damaged or ruined.

In order that we might get a general idea of the types of bearings with which our automobiles are equipped, it may be said that the bearings are divided into three general classes—plain, roller and ball. By giving the different names a little though the average person may be able to get a fair idea of the type of bearing that would come under any of these

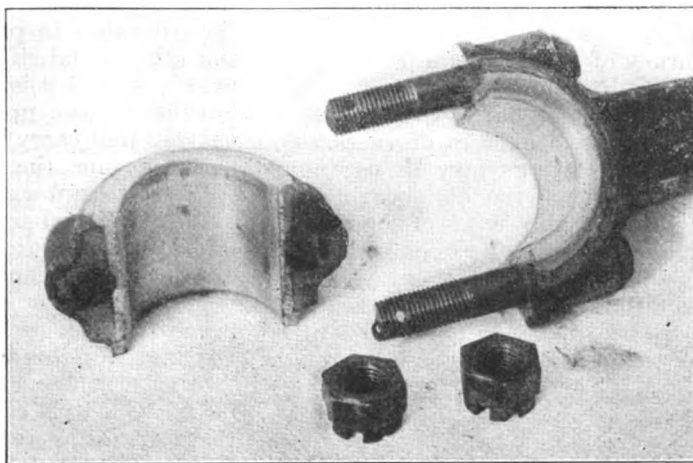

THE CONNECTING ROD BEARINGS — AN EXAMPLE OF PLAIN BEARING

heads—the names describe the types with considerable accuracy. To a more or less degree these bearings are not inter-changeable—that is, to a great extent each bearing has its distinctive field of usefulness, and in very many cases no other bearing would exactly "fill the bill" as does the one particular kind of bearing.

Plain bearings — The modern plain bearing consists of a cylinder which is open at both ends and split down the sides. As a rule this bearing is of bronze composition—although it is sometimes made of iron—with a lining of babbitt, a soft metal immediately against

which the rotating shaft rests. The babbitt and its supporting metal are locked together so securely there is little danger of them being separated while in use. As a rule grooves, some running crosswise of the bearings, others at an angle, are cut in the babbitt to permit of an even distribution of oil, this eliminating the possibility of the bearing being well oiled at the sides and dry in the center. These bearings are almost universally used in this country as supports for the crankshaft of the engine and also for the lower ends of the connecting rods—where they are connected with the crankshaft. Over in Europe ball bearings have been used to a limited extent for this purpose, but this idea has never gained any great headway in this country.

There is another type of plain bearing, which consists of a simple bronze cylinder, without the babbitt lining. These are sometimes called bronze bushings and they are generally used at the top of the connecting rods, in the clutch, on the brake pedals, etc. This type is used, in fact, in places where there is little danger of any great amount of heat being generated. It is not infrequent that one of these plain type of bearings becomes a little worn, thus permitting a trifle play between the connecting rod or the crankshaft and the bearing, the result of this being a knock. When this knock develops it is possible to remedy it by separating the two parts of the bearing and removing one or more "shims", or removal by filing a trifle from each side of the free half of the bearing, care being taken to remove the same amount of metal from each side. If too much is taken off shims may be inserted to relieve the tightness. Shims are very thin strips of metal which fit between the halves of the bearing. The laminated shim is made up of a number of layers and the removal of one or

more of these serves to take up the offending looseness or play.

While complete and efficient lubrication is necessary to the life of any type of bearing it is especially needed with the plain bearing. If a sufficient amount of oil is not present, the shaft rotating at a high rate of speed against the babbit, generally heats through friction and the soft metal is quickly melted, or burned out, as they say. This is denoted by the sudden appearance of an unmistakable knock in the motor, which should be remedied at the earliest possible moment. To neglect the repair of the connecting rod knock, even though it be a slight one, is to invite the possible ruination of the entire engine.

Roller bearings—This bearing is cylindrical in form and several inches in length, this, however, depending upon the use to which it is to be put. The roller bearing consists of a series of steel rollers located around the outside of this cylinder. This bearing is divided into two main divisions—straight roller and tapered roller. There are radial roller bearings and thrust roller bearings and combinations of the two. The principal advantage of the roller bearing is its enormous carrying power. There is hardly an automobile manufacturer in this country today who does not use roller bearings for his car's axle and rear wheel assemblies. Some manufacturers use ball bearings in the front wheels, this partly because there is not as a rule so much weight carried by the front wheels as there is by the rear wheels, and partly because more flexibility in operation is required for the front wheels.

The roller bearing needs the same care and lubrication as does any other form of bearing and if properly taken care of it will wear almost indefinitely, providing some flaw does not show up in the material of which it is made. If, however, it should be found that one of the rollers has become worn more than its companion, no attempt should be made to replace the single roller, but instead, an en-

tirely new set should be installed. By the time one of the rollers become excessively worn it naturally follows that all of the rollers in the same set will be worn to a greater or lesser degree, so that to put in one brand new roller along with the partially worn ones would prove just as unsatisfactory as to leave the overly-worn roller in in the first place. An entirely new set is required to maintain the ac-

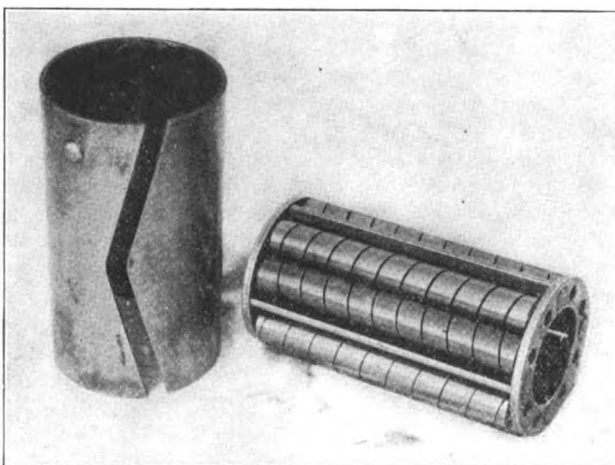

THE ROLLER BEARING AND ITS HOUSING

curacy of the complete part.

Ball Bearings—This bearing consists of steel balls which revolve between two holders or races. Of all the bearings now in use none can approach the ball bearing for flexibility and ease of operation, and whenever these qualities are the principal need there you will doubtless find this type of bearing. Ball bearings consume very little of the power that passes through them. There are more than one type of this bearing. First, there is the annular ball bearing, these having races in the form of rings. Another type has a holder or race "L" shape, with curved sides facing the balls. These are known as cup and cone bearings, and the principal advantage of this type is that it is readily adjusted, while the annular bearing is not. This type of bearing is also classified according to the way it carries its load as thrust or radial. Ball bearings are built to withstand both radial and thrust loads. Then, again, bearings of this character are built which have two rows of ball, etc.

From their very nature it may be realized that ball bearings must be exceedingly accurate in manufacture if they are to do their work properly. It stands to reason, also, that after they have been installed

within a car they must be given efficient care and attention if they are to work as well and last as long as they should. This fact comes more clearly to the user of the motor car when it is understood that to do their work properly these balls must not vary more than one-ten-thousandth of an inch. If this amount is worn from the bearing through under-lubrication its work will be impaired just as much as though it had been left this much too small during manufacture. As is the case with the roller bearing, if one of the wearing parts wears even a little, so that the replacement is necessary or even advisable, the only safe way is to install a complete new set of balls.

For lubrication of the ball, as well as the roller bearing, a medium weight cup grease should be used, and the motorist should be very sure that this is of the finest quality obtainable, for no grease is too good for the faithful bearing. If oil is used it soon runs away and the bearing is left dry within a very short time. This may also be said of the lighter grades of grease—these grades last very little longer than it takes to put them in. On the other hand, if the very heavy grease is used it is liable to become hard and cake upon parts of the bearing that carry little or no wear, thus causing the actual wearing surfaces to suffer.

There is nowhere in the automobile where absolute cleanliness is so desirable as in connection with the bearings. Water should never be permitted to come in touch with the bearings, for this will naturally invite rust, which might prove very injurious. It is also essential that the bearings be kept free from dirt, grit and other foreign substances. Every time it is found necessary to remove the bearing it should be thoroughly cleaned and furnished with pure, clean grease before replacing. At the most the grease upon the bearing will not cost more than a cent or two, while to replace it along with the old grease may mean that within that grease are foreign pieces of steel or grit that will eventually ruin the entire bearing assembly.

After the bearing has been removed the old grease should be removed with kerosene and either blown clean with compressed air, as is the latest method at complete garages, or carefully wiped with a perfectly clean, dry rag. After the grease has been placed upon it see that the bearing touches nothing

but the clean fingers before being replaced in its proper position within the machine. Caution should be exercised in the tightening of the bearing in its housing. See that the nuts are turned down evenly so as not to cramp the bearing in any way. Never be in a hurry while installing a bearing assembly. Take the work slowly and see that it is done RIGHT before it is called finished.

The foregoing are a few "high lights" on the automobile bearing subject, and these will give the "greenie" a fair idea of what a

bearing is and how it should be treated, if the maximum amount of service and satisfaction is to be received from it. To apply these facts to his particular type or car the motorist should study his machine. Let him get out the manual that is descriptive of his machine, and let him study it. If he does this the chances are that he will soon know the what, where and how of the bearings of his car—he'll be able to call his "blizzard" by its first name without feeling embarrassed.

are the enemies of steel welding, or what shall we study so we can become proficient? The enemies of steel welding are (1) The incorporation of iron oxide (2) The thermal disturbance in the vicinity of the weld (3) The expansion and contraction problems. Therefore one needs to study (1) The technique and properties of various steels (2) The phenomena produced during the melting of the metal under the oxy-acetylene torch, and (3) Boiler construction.

If one has the above knowledge in a sufficient degree, the welding in itself will be then comparatively easy and successful; but if he has not, and failures or accidents occur to him, he will consider and insist that certain operations are unpractical or impossible to perform with the oxy-acetylene blowpipe. This is one of the reasons why certain companies will not trust the apparently good looking welds, and reserve to themselves the right to sanction or forbid boiler or pressure welding.

In studying the first theory of the incorporation of iron oxide in the weld, one must know, what iron oxide is, and what it looks like? Iron oxide is a burnt element, created on the surface of molten steel under the action of the blowpipe and the atmospheric oxygen. The appearance of it is like white veins and foaming spots.

In the early days when I found that my good looking welds, failed immediately, or six months later. I thought that this oxidation was an uncontrollable enemy in the weld-trade, and was ready to drop all welding on pressure vessels. Still inwardly my conscience told me there was a remedy, and that I needed to study the anatomy of steel, the same as the surgeon studied the anatomy of a human body before he commences to weld a human limb.

Iron oxide will dissolve into the molten steel at the rate of a little higher than one per cent, and in this reaction it may destroy the carbon elements with the result of a decrease in the strength and elasticity of the weld.

The best remedy to reduce oxidation is to reduce the oxygen pressure as low as possible; just enough to produce a free and soft flame, that will produce a continuous melting without running over the edge or in plainer words, a melting without too much exaggeration. This operation, depends largely on one's blowpipe, and the

and mixtures of crystallized and laminated pearlite. After the first heat treatment we see a finer grain which consists of a martensitic structure. The last two of the third treatment show the same fine grain but practically all the martensite is transformed into an intimate mixture of sorbite and troostite with martensitic characteristics.

STEEL WELDING

E. K. Smith

The question of steel welding, is one of the most important of all the problems which confront the oxy-acetylene welder. A large part of this problem has to do with his preliminary knowledge of steels and his primary habits of handling the blowpipe in steel welding. The welding in itself is apparently one of the most easy to obtain and the

misfortune is that some welders are considering steel welding as a subsidiary problem of their trade, and are passing it with a light heart, because their welds look so well; yet steel welding, notably in boiler welding, requires the most thought and care, and should be studied not only from the practical point of view, but also from the theoretical end of it. And what

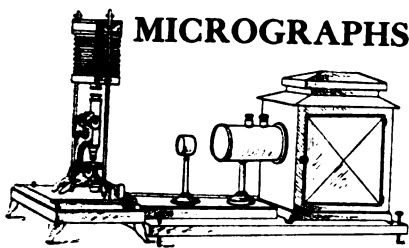

MICROGRAPHS

In making micrographs of metallic specimens a disc of metal is given a very high polish and is then etched with some chemical that will develop the structure of the metal. This specimen is then placed under a microscope and illuminated from the top by a special lamp. If it is desired to make a photographic record of the structure a camera is placed in line with the microscope.

Here we have six micrographs of steel used in high grade automobile springs. The magnification is 1150 diameters; that is, the area shown here is actually

765,000 times greater than the space it represents on the actual specimen. These are arranged from the upper left hand corner to the lower right in order to show the progressive effect of heat treatment. The

first two at the top represent the raw material untreated. The third one in the top row and the first in the bottom row show the conditions after the first and second treatments. The last two in the bottom row show the final condition of the metal after treatment. The original metal is a coarse crystallized pearlitic structure with little free cementite

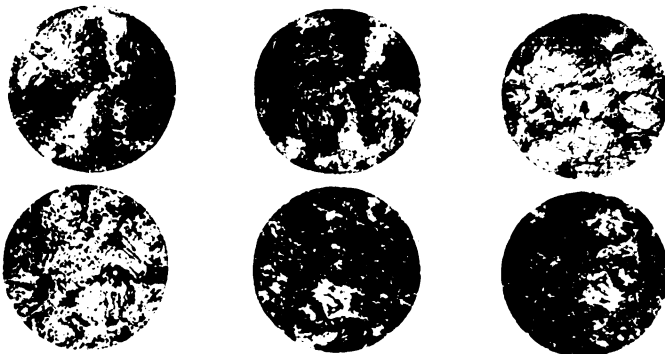

flame maintained throughout the weld.

With a proper flame, one will notice the flow of the metal clean and regular, but with a too rigid flame which requires more oxygen, one will notice sort of white veins and foamy spots flowing in the molten metal. These are streaks of oxide of iron, and they will dissolve and create new ones with the progress of the weld. The molten metal is swept rather, than laid in formidable clean layers, and in some cases the metal is adhered instead of welded.

Oxide of iron cannot be altogether eliminated from any kind of weld as long as we cannot protect them from the effects of the atmosphere, but it can be so decreased from the interior of the weld, that its contents would do no harm to the strength of the weld.

The secondary remedy to decrease oxide of iron, is to use a good and well known blowpipe, that will deliver a normal flame, and consume about an equal proportion of oxygen and acetylene. Reliable regulators and strong gauges will also help to maintain a continuous steady and normal flame. The welding rod must be a clean soft charcoal or electrolytic iron, if good results are desired.

Some of the men who are known as good and experienced welders and probably have been welding for five or six years, but who have met with some failures in steel welding, will not admit that the main cause of failure is on the improper regulation of the flame, and why? Because the regulation of a welding flame is the very beginning of the letter A in the alphabetical study of oxy-acetylene welding. It would be the same as a college student who would be compelled to return to the grades, and learn the A, B, and C. Yet it is so.

Most of our welders having previously mastered some other craft, have begun welding important operations, without any preliminary instructions. In other words, he began at the college without knowing the primary and high school education; which is the rock foundation of any student or craftsman.

What would a boilermaker think, when a novice would try to put in a set of flues in a boiler? Or a machinist, if an apprentice would make a set of dies? Yet the same boilermaker or machinist approves and looks upon the welding blowpipe as a part or helping instrument

to his trade and all he needs to do is to go ahead and weld.

In studying the second theory about the thermal disturbance, that is produced by the gas flame on the metal, when it is raised to a fusing temperature, or in other words, a considerable change in the growth of crystals, that will set in the vicinity of the steel weld. It will appear that the agent that causes trouble is heat. However, we must not forget that it is heat which created the birth of many new steels, and while heat can be employed to increase the lift of metals, heat can also reduce and destroy the life and strength of metals. Therefore, if this agent is



at our disposal, it remains for us to study how we shall employ it, so as to obtain the best results.

It is a well known fact that the structure of any gas weld at the welding line, on a boiler plate for instance, is a cast metal. This metal is much lower in elongation than the boiler plate. Yet the structure of the boiler plate was originally at the mill a cast metal or something similar to the gas welding line metal. But, it has been refined by the operations of heat and mechanical treatment, to a strong metal that we call boiler plate.

The question is then, can we employ the heating agent with the aid of the gas blowpipe, to refine the grain at the weld and its vicinity? My answer is, "Yes", provided the the operator knows the physical and the chemical properties of boiler steel.

In studying the third theory, the expansion and contraction problems; personally, I was not exempt from failures and when I look back at the times when I could not understand why my good looking welds would crack in a boiler; was like looking back at our ancient welders, when they hammered the metal with a stone in the form of a half globe, without a handle, on a flat rock anvil.

There is no more, such a thing as

not to be able to take care of expansion and contraction in steel ~~welding and the problems of solving this phenomena are great and interesting.~~

In boiler welding one will find these problems difficult to solve, unless he has a full knowledge of boiler construction. Yet the affects of expansion and contraction are less feared by some boiler welders, because the metal to be welded possesses the property of elongation. However my advice is that no welder should depend, that the metal will give and that a little strain will not hurt the weld, for two reasons.

My first reason is, that almost in all cases, an intelligent welder can find a solution of how to take care of the expansion and contraction. Second reason is that no human being can ever measure, or know how much of a strain is felt in the metal. It may be very little or it may be to the breaking point. Such a weld may crack during the progress of a weld or a few days after; at any rate the welder is not excusable and the failure will condemn the operator, the process, and the whole industry.

I cannot take too much time to enumerate all the problems of expansion and contraction as they are indefinite in numbers.

There is one point that an oxy-acetylene operator must bear in mind, and this is to make a strong weld. Economy should be considered as a secondary principle. While there must not be any useless waste in time or material; yet we must not forget that a defective weld is a waste of time and material.

Furthermore, there is our competitor the electric welder, who claims economy over the oxy-acetylene process, nevertheless efficiency and reliability is on of the side of oxy-acetylene process, and although we lost out at the shipyards at present, on account of such careless and ignorant welders, yet we will win in the end after we can educate our welders, and prove efficiency.

The welder that can make the strongest weld, will get the business and preference, regardless of the higher cost, therefore. I believe it is time that some of our operators investigate these three theories in steel welding, and make further improvements for the benefit of himself and that of the welding industry.

VALVE REMOVAL

In engines having demountable heads and valves in the head, the removal of valves is a matter of difficulty, unless one has found out just the proper trick. The head should be laid on the bench, right side up and the compressor slipped

on, after which a wire should be fastened about the handle of the compressor and then be anchored to the leg of the bench or table. Next lift up on the handle; this presses the spring down, the lock may be removed from the stem very easily and the job is done.

the polarity is reversible and the connections can be made any old way and no trouble will happen.

At one end of the housing there is a six ampere fuse. This is connected in the field circuit of the generator. If the generator is ever disconnected from the storage battery it should not be run without first removing this fuse. If the battery is removed from the car and the car has to be operated, dry cells can be placed in the car for ignition but this field fuse should be taken out. The lights can be taken from the storage battery without any trouble, even if the generator is taken out.

The starting motor has a square shaft that has a pinion that slides horizontally along this shaft. This pinion meshes into the teeth on the fly wheel. This method does not need any other gears or clutches. The starting switch is located in the center of the car in front of the control levers, and connects through a linkage to the shifting fork which slides the pinion on

The Hupmobile Electric System

M. H. GEORGE

The Hup model N, King model E. E. Scripps-Booth, Jordan all models, Nash and Apperson are among the list of cars using the well known Bijur system.

The Bijur Lighting and Starting equipment on the Hupmobile engine consists of a generator and motor accessibly mounted on the right-hand side of the engine.

To replace the brushes all one has to do is to take off the band that is around the end of each machine, this band is held in place with a thumb screw. Of course the starting motor is in operation only when the engine is being cranked. The generator is driven with a chain from the crank shaft and is running whenever the engine is. The chain is entirely enclosed and runs in oil and therefore, does not need any attention aside from adjusting the chain when it gets loose. This is done by loosening the nuts on the three bolts on the front of the chain case and swinging the generator outward until the chain is tight. Do not tighten too tight. A good way is to swing the generator out until the chain is tight and then swing it in until it is a little slack, then tighten the nuts. If the front cover is off of the chain case one can see just how tight the chain is and it is best to have it so that it will lift up and down about one half inch. I mean by this just one side of the chain.

When the engine is running at a speed that corresponds to a car speed of ten miles an hour on high gear, the generator is furnishing current for the lights and the storage battery, and if the lights are off all of the current goes into the storage battery to be used some other time for lights and starting motor. These machines are self contained and there are no regulators or automatic switches but what are in the machines.

There is an automatic switch for opening and closing the circuit between the generator and the storage battery, this is inside the generator and is supposed to be adjusted but sometimes the points will get dirty or one will have a high place on it and it will bridge across the gap and cause trouble, if this happens the machine should be sent to the makers or else taken down and the points filed smooth with a file made for this purpose.

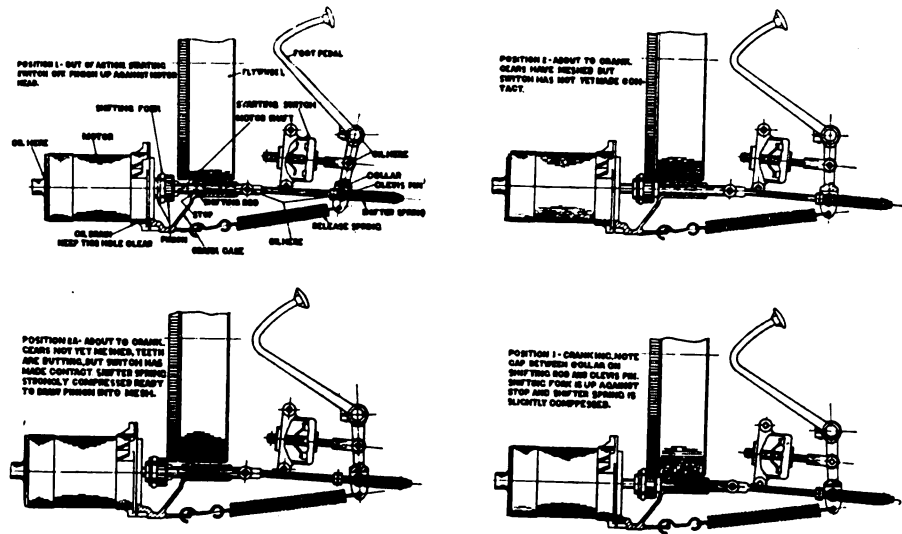

OPERATION OF HUPMOBILE STARTER

When the points stick together and the heavy current comes back from the battery the coils are usually burned so that the only way is to send the whole machine back to the makers and let them repair it.

There are two wires that come from the generator, one of these you will find is connected at the starting motor to one of the heavy wires that come from the storage battery, the other wire is grounded on the frame of the car, the frame is a part of the circuit. One fine thing about this generator is that

the square shaft of the motor.

This same foot pedal is the one that operates the starting switch. When the foot is not on the starting switch pedal a spring holds the gears out of mesh, and the starting switch is in the off position. In starting, the foot pedal should be put down with a quick movement and as soon as the engine starts to fire the foot pedal should be released. If the engine does not begin to fire in a few seconds, the pedal should not be held down, as it exhausts the storage battery. One should look things over and

see that there is a spark at the spark plugs and that all connections are tight and that gasoline is coming to the carburetor.

The lighting switch is on the cowl and has four positions. On the front side of the switch there are four fuses and the dimming resistance for the head lamps. If you are in the driver's seat the fuses are in the following order from right to left: 1.—Rear lamp fuse. 2nd.—Instrument light fuse. 3rd.—Horn fuse. 4th.—Head lamp fuse. On this car there are spare fuses in clips on the left front door

the switch in this position. When the switch is in the third or "Dim" position the tail lamp burns bright and the head lamps burn dim and the instrument lamp is bright. This is the way that you need them for ordinary city driving. The fourth position or "On", all lamps are at full brilliancy, in this position the resistance is removed from the head lamp circuit. Do not leave the switch in this position when the car is standing as it draws a good deal of current from the battery.

If the starting motor fails to

motor. Third, the brushes may not touch the commutator or may not touch evenly. Fourth, the motor may be damaged inside. I saw one that was taken out as we supposed that a bearing had become dry and set so the armature could not be turned. We found that the wires were out of the slots in the commutator and some of them worn nearly off and the rest wedged in next the field magnets so that it could not be turned. The motor was sent back to the service station and the bill was something like seventeen dollars. Of course there are a lot of other things that will put the electrical apparatus out of business and I shall mention others in further articles.

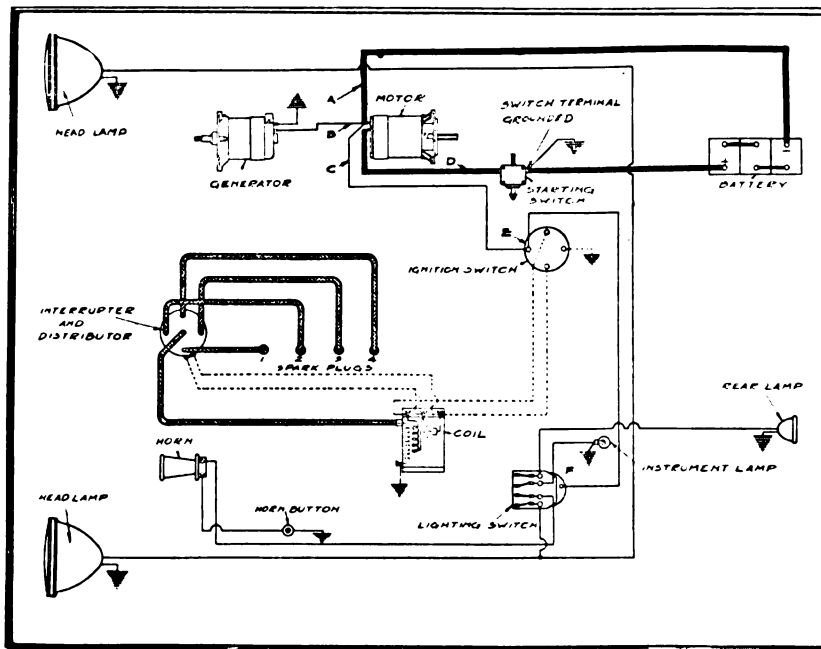

HUPMOBILE-BIJUR DIAGRAM

hinge pillar, concealed by the shroud trim panel. These fuses are of 10 ampere capacity and should not be placed in the generator field circuit only in case of an emergency. The generator field circuit has a six ampere fuse and the ten ampere fuse will not protect it properly. As before mentioned, the lighting switch has four positions. The ones on the outside being marked "Off" and "On", and the two on the inside positions marked "Dim". If the switch is on the first position "Off", all lights are out. In the second position "Dim", the tail lamp burns bright and the head lamps burn dim. The resistance on the back of the switch is in series with the head lamps in this position. The instrument lamp is not burning when the switch is on the "Dim" position. If the car is left standing at night it is a good plan to leave

crank the engine, there may be a number of different things causing the trouble. First and most important, and sometimes the most expensive, is a discharged storage battery. If this is the trouble the lights will burn dim when the engine is still. The remedy is to have the battery taken out and charged at some charging station. First it is best to run the engine awhile and see if the battery will take a charge. If after running the engine for an hour the lights come on bright, you will know that the battery is being charged. If it runs down again after the battery is charged look for bare wires somewhere. Sometimes a battery will not hold a charge, and then about all you can do is to send it to the service station. Second, there may be loose or broken connections between the storage battery and the starting

REMOVING RIM RUST

To remove rust from the rims of a car, jack up the rear wheels and start the engine running in high. The wheels will spin and emery paper is applied to the rim with a block and the rust will be eaten off in short order. By removing the fenders and running a band from the rear to a front wheel, the same process may be repeated with the front wheels.

BRAKE LINING HINT

The use of split rivets instead of the solid type makes the operation of relining the brakes very much simpler. The rivets are inserted so that the heads are against the metal bands. The split end is opened out and sinks into the lining. A round steel bar inserted in the jaws of the vise makes an ideal tool for spreading the split rivets in place.

DRIVING NAILS IN HARDWOOD

Most woodworkers know that common yellow soap, daubed upon the end of a nail will enable them to drive the nail in hardwood without bending it.

A very handy way of handling nails for hardwood driving is to stick the required number of nails in a cake of soap, like pins in a cushion. In this way, the nails will be conveniently at hand as wanted and the several sizes required may be selected instantly, ready at hand.

Automobiles using gasoline for fuel were prohibited from all ferryboats until early in the year 1901.

A TRACTOR FOR THE MARKET GARDENER AND SMALL FARMER

"My farm isn't big enough for a tractor" is the only objection that many of the smaller fry of farmers and market gardeners have against the tractor.

Now that we see the tractor has been generally and enthusiastically adopted by the farmer generally, let's see what we can do toward equipping the man we have just mentioned, with a tractor that will "fit" not only his farm but his purse.

Although known by the unpretentious name of the Beeman "garden" tractor, let it be understood that this tractor will do as

much and more work than one horse will.

A few particulars concerning this tractor will doubtless give one a clearer understanding of what it is and what it will do.

The tractor is driven by a one cylinder, four cycle motor with a 3.5 by 4.5 inch piston and develops four horsepower on the belt and 1 1/4 horsepower on the drawbar. It is guided just the same as a lawn mower, using gasoline for fuel and its speed and power is governed by a throttle attached to the right handle while the clutch control lever is attached to the left handle.

The speed of this machine in the field can be varied from 3/4 of a mile to three miles per hour and the engine speed can be varied

from 230 to 1,500 r.p.m. The engine is cooled by a thermo-siphon system with radiator and fan. Ignition is furnished by high tension magneto and lubrication is by splash and gravity.

The height is 40 inches, 86 inches in length and 17 1/4 inches wide with a clearance underneath of eight inches and between the wheels of ten inches. This permits of its being used astride rows where crops are planted from 10 to 16 inches apart or between the rows where crops are planted more than 23 inches apart.

Although designed primarily for cultivating vegetables the machine successfully handles all one horse tools, such as plows, harrows, mowing machines, lawn mowers, irrigating steels, etc. A pulley attachment makes it readily convertible into a stationary engine.

Now, we have a tractor for everybody who cultivates the soil and the only thing remains to get the farmers and others interested—less than \$300 is the cost.

Keep waste paper, packing material and rubbish cleaned up and removed from the building at least daily.

Make frequent personal inspections from a fire standpoint.

Instruct and drill employes on what to do in case of fire.

Be careful about the use of matches.

Put up "No Smoking" signs, especially in hazardous sections.

Locate your nearest fire alarm box and learn how to turn in an alarm.



Teaching the young idea to stay on the farm and like it. If he had to hoe this patch of onions by hand he would be thinking about running off and joining a pirate band.

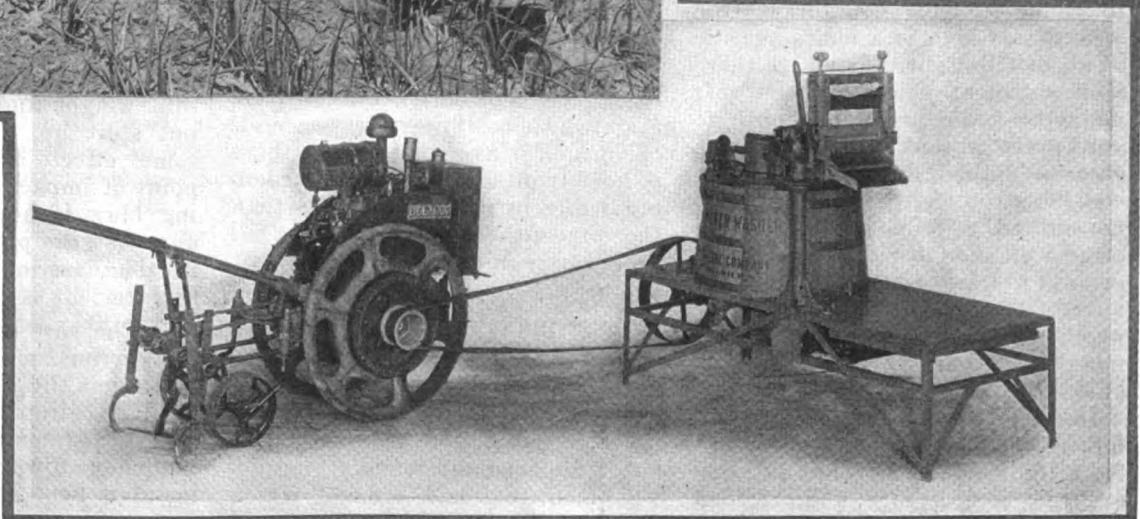

EVEN WASH DAY IS ROBBED OF ITS OLD TIME TERROR FOR THE "WIMMEN FOLKS"

CHILLING AND CASE-HARDENING.

Mark Meredith

These terms are applied to cast and malleable iron (or steel) goods respectively, the working results being the same, but the methods and effects on the two forms of metal being different, chilling causing the cast metal to hold the carbon in suspension in the "combined" state so far as the chilled surface is concerned, while case-hardening is produced by the metal absorbing carbon, and then being quickly quenched. Although not the same as case-hardening, the surface hardening of copper and other non-ferrous metals can be accomplished by surface alloying with tin or other suitable metal at certain crucial temperatures, and this acts as a hardening medium much as the carbon acts on iron and steel, although the metals do not assume a gaseous state during the process as in the case of carbon.

In making chilled castings, the molten metal is run into or against whole or part moulds of cast iron of some thickness which at once solidifies the metal without allowing time for its constituents to separate and assume various forms as in a sand mould, suitable mixtures of iron being used, as some irons are non-chillable. The depth of chilled parts depends partly on the iron used and partly on the thickness of the chill in regard to the bulk of the casting but up to roughly half-an-inch chill can readily be had under suitable conditions. In cases where the whole of the metal is chilled, it becomes brittle and for this reason makes it necessary to use specially selected iron, which, by its strength, will to some extent counteract the weakness which is a characteristic of all brittle irons, but where there is a sufficient thickness, the soft metal prevents loss of strength to any great extent, while in some cases a chilled casting may very well be stronger than one which is not chilled. Chilled surfaces stand wear well, and usually have to be ground to finish them, as a file is of no effect on the hard surface, but given a sufficient backing of soft metal, such surfaces are very durable.

In case-hardening the articles are finished as to size and form, except for a light grinding where extreme accuracy is necessary, and are then packed in flasks in the carbon producing material, which is usually



IMAGINE THE JOY OF CULTIVATING WITH AN IMPLEMENT LIKE THIS

some form of animal charcoal plus prussiate of potash, salt, other chemical, which is presumed to assist in the absorption of the carbon. The flasks have covers thoroughly luted on to prevent the admission of air, and are gradually heated to from 750 deg. Cent. to roughly 800 deg. Cent. and held at that temperature for some hours. The exact temperature depends on the content and bulk of the metal, and but usually the variations are not great. When finished, the hardened pieces are dumped into cold water, and after being dried are finished off for use if the hardened casing is thick enough, or it may be necessary to again pack and heat them to increase the depth of the hard casing. As to the depth to which the metal is hardened, wear has to be considered, but as from a sixteenth to three thirty-seconds of an inch is as a rule ample, there is no advantage in deeper hardening while in many cases less than the sixteenth of an inch gives all the wear required.

For thin work, heating to a full red and plunging in a hot solution of cyanide of potassium will give good results, more particularly if the heating and dipping is several times repeated; but this method of hardening usually causes the development of hair cracks, which rather spoil its effectiveness, and to some extent provide a means

for rapid wear under some conditions of use. The hotter the solution is used the fewer and finer the cracks with steel, while with fibrous iron they become practically absent, but all wet treatments are rather apt to affect the surface of the metal, and this in the hands of the most skillful operator.

The advantage of case-hardening is in its providing a very wearing surface—as in the case of a wheel axle—while still retaining the toughness of the general body of the metal, in this way providing a safeguard against shocks which fully hardened metal could not withstand this being the objective aimed at in both chilling and case-hardening. The full effect of the method is well shown in some armour plate, which will resist the penetration of shells under a certain weight and velocity, and yet not split up, although, probably, some effect is produced at the point of impact provided the striking blow is heavy enough, but in any case the plate is not ruined as in the case of the non-hardened surface.

In the case of surface hardened non-ferrous metals, the effect is somewhat the same as in the case-hardened iron or steel, while in some instances there is some tendency towards peeling if the metal is bent about much, but the process has advantages for some kinds of work. The metal to be

treated is freed from oxide as far as possible, fluxed, and sufficiently heated from underneath, the hardening metal being melted on the upper surface and well rubbed in until it alloys with the metal to be hardened. Surplus metal is then wiped off and the treated object allowed to become cold, when it is finished in the most convenient way. Copper can be made so hard with tin that a file will scarcely touch it, while other things can be made surface hard, aluminium possibly, being an exception, as under heat it does not behave like other commercial metals, although phosphorus causes the situation to some extent. Provided someone would produce an easy method of surface-hardening aluminium however, and that without sensibly increasing its weight, the thing would be of much value if only imparting rigidity, but it is not required for more than surface-hardening, and not general alloying purposes.

OVERHAULING THE CAR

This is the time of the year that an all wise Providence has created for the benefit of motor car repairmen. It is not that it is a particularly favorable season for driving, which is practically impossible in the North and not particularly enticing even in the Sunny Southland. But anyhow, this is the time of the year that the car owner begins to think about overhauling his car for the "spring drive" and most of the car owners are not educated up to that point where they are able or willing to undertake this job themselves and if they do—well—the repairman will have to be consulted sooner or later.

The best way to attack the overhauling problem is to begin at the engine and work backward, going over each unit piece by piece. If the engine has a detachable cylinder head, and most present day models have, this should be removed so that the interior may be inspected.

It is possible that some work will be needed on the bearings but like everything else, unless there is any necessity for disturbing the bearings they should not be bothered. Unless there is evidence of wear; looseness, end play of cam and crank shafts etc. Naturally any unnecessary looseness will be looked for and remedied. In working on the engine the oil base will have to be taken off and this affords

an opportunity for cleaning out the splash pans, the oil tubes and other parts with kerosene.

If it should become necessary to take up any bearings, either on the connecting rods, or on the crank shaft or cam shaft do not make them too tight, for the removal of a little bit of metal goes a long way toward tightening up a bearing, so work carefully and sensibly. It is not at all common to find that one side of a bearing has been taken up a little too tightly so that the other is readily free in its movements. Therefore, be sure to remove the same number of shims from both sides or scrape approximately the same amount from both sides of the bearing. It is an exceptional case where one side of the bearing will require much more scraping than the other.

It is a good idea to take the entire connecting rod out and inspect the piston rings for possible broken rings, the condition of the bearings, wrist pin bushings, etc., and while they are out, take a small mirror and look for scored cylinder walls. If you find that the cylinders are scored it will, of course, be necessary to rebore them and it is better to rebore all the cylinders in such a case rather than just the one or two that may be scored.

The oiling system is the next thing that should come in for attention and obstructions in the oil lines should be looked for and all screens and strainers in the oil base, pump, etc., should be carefully cleaned.

The valves should also be carefully looked after—removed and ground and while they are out give them the "once over" for warped stems and heads. Each valve should be fitted to its guide and if there should be too much play, a bushing should be placed in the guide, or a new valve with an over-size stem should be fitted.

The cooling system usually needs a good cleaning out and the radiator should be cleaned out either with some of the cleaning compounds that are on the market or by using a hot solution of soda. The rubber hose connections will probably need to be renewed. If the cooling system has a water pump new packing should be put in the packing nut, being careful not to screw the nut down too tight in replacing it.

The ignition system generally calls for considerable attention.

All the terminals should be cleaned, breaks in the insulation taped or new wires put in, connections tightened and loose wires fastened so that they will not come into contact with hot metal. The ignition unit—the timer and distributor, should be given a thorough cleaning and oiling and the ignition points should be trimmed flat.

The starting and lighting systems should need but little attention. About the only thing necessary is to give the bearings proper lubrication. If the silent chain drive is used the chains should be cleaned and thoroughly lubricated. All chain slack should be taken up and this applies to cars having chain driven timing gears.

The fan assembly will perhaps need tightening up a little and the fan oiled and cleaned. All connections and bearings in the clutch assembly should be cleaned and lubricated freely. The transmission bearings may probably need replacements or taking up and this is something that the owner—if he attempts the job himself—will have to take to the repair man.

A general tightening up of all the various mechanical and chassis units generally is advised. If the chassis includes torque members, will probably need tightening. Look over the whole chassis for missing nuts and bolts, spring clips, etc. Go over the steering gear from post to axles, replace shaky parts and take up all slack except about a half or three quarters of an inch play in the wheel which makes for ease in steering. The braking system should certainly be given attention. The brake hands and brake shoes will probably require relining and all brake rods and other accessories should be very carefully inspected.

Finally the whole rear axle should be gone over. The rear wheels should be jacked up from the floor and the car placed on blocks, and the engine started and any untoward or unnecessary noises here should be located and remedied. This will naturally require taking off the differential housing and whether or not there is anything wrong with the differential, the old grease should be thoroughly cleaned out and new grease put in. The differential is one of the hardest worked parts of the entire automobile mechanism and should be cared for accordingly.

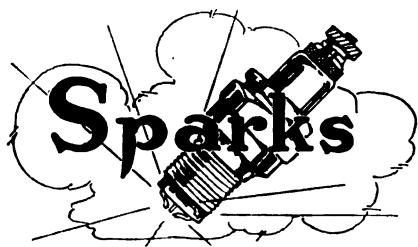

How One Man Defines "Nerve".—Once in a while some man appears who can use words contained in the English language to express thoughts which sparkle and vibrate with inspiring energy. That make the nerves tingle with the same stimulation which comes from the tang of a frosty fall morning. Here's what one man says about "Nerve":

"Nerve is not a new virtue. Nerve has always existed, even before David went out of his class to meet Goliath. Our forefathers called it pluck. Nor is it a single virtue. It is multiplex. To stick to the wireless keyboard of the floundering 'Republic,' flashing a cry for help that quivered through the civilized world—that is nerve.

"To finance a gigantic deal, requiring millions of real money, acid tested, and up to the purity standard of Caesar's wife—or with three men on bases and two men out in the ninth inning, to fan a mighty batter—plain nerve.

"It takes a big measure to encircle the word nerve. It is the biggest word in the business lexicon, and the countersign that admits to the inner chambers of success.

"Nerve is no unit virtue. It is the amalgam of many. In its composition are self-confidence, courage, energy, grit, hope, enthusiasm ambition endurance—and then a surplus.

"A man with nerve must perforce be accused of conceit mostly by the envious and one-cylinder brained, who are unable to distinguish between conceit and confidence. Conceit is 'I' in speech; self-confidence is 'I' in deed.

"Nerve makes a man sure of himself. It destroys hesitation and takes the wobble out of the mind and out of the legs. A man with nerve believes in himself. He knows that he can. Doubt and timidity are strangers to him, and his confidence inspires the confidence of others.

"The man of nerve becomes a leader of men. He is magnetic; he attracts men. He is galvanic, and commands respect.

"Nerve begets courage. It puts fear on the scot, and is the stuff of which heroes are made. It goads them to dare to do.

"Nerve supplies energy. The man with nerve does not drop nor sag in the middle. His head is high; his chin is up; his shoulders are squared and his back is straight.

"Nerve shows in a man's walk and conversation. Neither his foot nor his tongue falters. He has a militant tread and talks with emphasis. He uses a chair chiefly as a stepladder to reach higher, and his only rest is in bed in refreshing sleep.

"The man with nerve is a smiling whistling optimist. He oozes hope. He basks in continued sunlight and success surrounds his horizon. He doesn't know failure, and would decline an introduction. His enthusiasm is as infectious as the laugh of merry childhood. Whatever his proposition, it is a winner. He thinks so—and that makes it so. Furthermore, he has endurance. Discouragements may

beset, obstacles may arise, but he stays, he fights, he triumphs. Why? Because he has stamina. Nerve wins the long race and the hard struggle. Any trainer of athletes will certify that nerve has won more championships than speed or brawn.

"Nerve is the greatest human asset. It puts a whistle on the lips, tabasco in the blood, cement in the backbone, and spunk throughout the body.

"When you've lost your nerve your're through."

Now along comes some fool congressman and says that "It doesn't take as much sense to be president as it does to be a congressman". Naturally, it wouldn't be possible to get all the fools in congress.

Today's a nice day for poems on sweet peas, I. W. W's., horseradish and show-ers.

A Tennessee paper tells us that "Walter Andrews brought a green horned worm to town Saturday that ate an English sparrow". The worm must have had a drink of some of the stuff that they turn out up in the hills when the revenue officers aren't looking.

Have you decided what your "text" will be when you write us that letter?

Well, Christmas was a great day, even if we are broke, and all our Christmas neckties do show up soup stains to advantage.

In all seriousness, we wonder that a lot of shop owners don't wake up to the fact that the day has passed when people kept books and business records like they did in Washington's day. Still there are lots of them who still stick to it and who feel that so long as they have a dollar in their clothes that they're making money.

Dispatches seem to make it appear that the Chilean bite is worse than the Peruvian bark.

Most people are under the impression that it doesn't matter so much what Germany can pay as what she's got.

In Montenegro they call Congress the "Shupshтна". Even in a free country like this no one had had the nerve to call Congress anything like that.

The task of establishing a new German government has been simplified by making it unnecessary to have either a Minister of Colonies or Minister of the Navy.

It may interest some of the good people to know that the Y. M. C. A. is selling more cigarettes than any other concern in the world.

People who are worrying themselves nutty over what the nation is coming to might help the situation some by getting busy on some job of useful work.

It's better to have a man come ten miles out of his way to give you the job than for him to go ten miles further on to get away from you.

If at first you don't succeed, make another trial trip.

You never can tell. Lots of men are cranks and yet you can't turn them down.

Mighty few people are satisfied. Even the red headed man hates to think he is getting bald.

Remember that even a casual customer may send you hundreds of dollars of business by recommending you to his friends or, on the contrary, may give you a bad name all over the country. Don't send him away thinking "I was a stranger and ye took me in."

Love is the tender passion, but when it is unrequited it's pretty tough.

And you can't make a woman believe that shoes should be larger than the feet that wear them.

The flu and the war have gone out about the same time and everybody's happy.

Hell is paved with good intentions that have gone to the bad.

If a colored girl married a man named White, could it be said that she turned white when the parson pronounced the words?

We suppose that the down town of a city is always called the heart of the town because there are so many "beats" in it.

Over in Germany they have been putting sausages in bark. Over here they put the bark in the sausage.

O, Young Lochinvar came out of the West, no "chaps" on his legs or fringe on his vest, the which disappointed the maids, you must know, whose ideals came from the Gem picture show.

A Mercyville, Iowa newspaper tells us that "Markham's milk wagon is making daily trips to the lake now." May we ask what the object of this trip to the lake is for?

This isn't anything new, even if the politicians do try to make you believe it. It was said by William Pitt almost 200 years ago "I am sure I can save the country and I am sure that no one else can."

A Boston publication is giving aeroplane lessons to its readers. This is interesting because as far as we can learn this is the first attempt on the part of any publisher to kill off circulation.

Being in love with your work is the first rule of success.

Why is it that every time a girl quarrels with a fellow she wants to become a trained nurse and he wants to go prospecting in the Black Hills?

Give a hungry man something to eat before handing him advice.

The world has no time for a visionary man until he gets there.

The non-committal editor—"Those who know Edward Tillinghast will be interested to know that he has resigned from the orchestra. He made it what it is."

All men are anxious for favor but some will accept money as a substitute.

Education is good provided it doesn't unfit a man for honest labor.

When a man helps his wife with the housework, it takes him about twice as long to finish.

When you wake up to the fact that you don't know much, stop talking and give others a chance to put you wise.

Why the socialist party grows—"Mrs. William Watt Sherman's Pomeranian "Baby" is ill at the Hotel Ritz."

The recent slogan of "work or fight" now gives way to the old rule of "work or starve."

We see that our Friend Henry Ford is going into the newspaper business—he ought to get out a rattling good newspaper.

From the great wall that has gone up we begin to feel that the Pan-Germans have become panhandlers.

About the only difference between a Bolshevik and a bourgeois is about thirty kopecs.

Betcha—there won't be a turned up mustache in the wide, wide world this time next year.

The absence of the price of a meal is the best appetizer known.

A PLEASURE TO GO TO THIS SCHOOL

Albert Mørp'e
 "First, God made idiots; that was for practice, then he made school directors"—Mark Twain

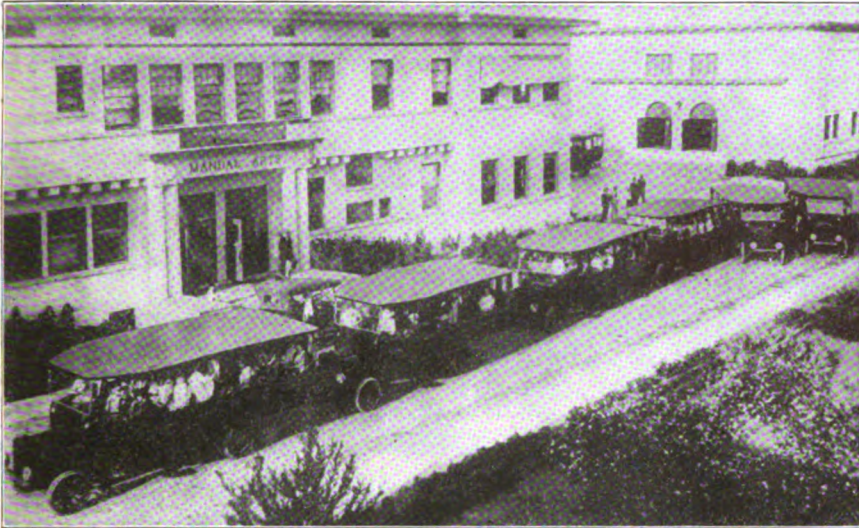

The inimitable Pud'nhead Wilson thus speaking of school directors doubtless spoke the truth but present day school directors need not take offense because this philosophical character of Twain's lived before he could meet the school directors of the Fullerton Union High School, out in California.

A great many of the students attending this school lived not only one but several miles from school and the matter of attendance was a serious question to faculty and students. Finally the school board decided to adopt the original solution of bringing them to school in automobiles. With that object in view, one truck was bought and put to work on a selected route. The results were so satisfactory that the township now owns eight big passenger cars of the type shown in the illustration.

The only expense connected with the operation of these trucks is for fuel and tires. The students in the mechanical departments keep them in repair and running order and the trucks are driven by the students themselves so that there is no expense for drivers.

HARDENING COPPER

Mark Meredith

Has the lost art of hardening copper been re-discovered? It certainly appears so if the claims made by an American instrument maker are well founded, as they appear to be. In parts of Central America particularly Yucatan, implements apparently of copper, but possessing a high degree of hardness, have been found, and a difference of opinion exists as to whether this was obtained by heat treatment and tempering or by the addition of some other metal to the copper during the smelting. The re-discoverer of the art of hardening copper says that all his experiments, of which he has made hundreds go to show that tempering copper is impossible, and that it is also impossible to harden it by hammering, in either a hot or a cold state. It has long been known that a certain hardness could be imparted by adding tin and latterly the inventor of the new process turned his attention to the experimenting with alloys of copper and one or other metals not usually associated with it. Eventually he met with a large

measure of success, and before long was able to produce a balance-spring of copper, which has been tested by a large number of people interested in the metal trades. To show the value of the new alloy, which contains so small a percentage of the added metal that it practically answers to the tests for pure copper, he drew a piece of the new wire down to such fineness that it was made, at his request, into the balance spring of a watch, and the time-piece not only goes, but keeps time quite as well as those made with the more orthodox materials. "My copper will take a keen edge" says the inventor, "and will hold it under some conditions where steel cannot do so." Whilst containing a small percentage of tin, it also is alloyed with minute proportions of other elements which so far the assayer has been unwilling to name, but which is known quite well. What is probably the strangest thing about it is that the alloy can be melted any number of times without losing any of its distinctive characteristics. In other words, once-hardened the copper remains hard.

Benton's Recipes

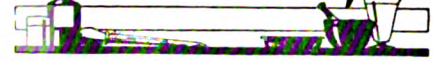

Mixing Plaster-of-Paris.—Almost every one has to mix up gypsum or plaster-of-Paris once in a while, but few know how to do so as to make a smooth cream, or thin dough, without lumps. The trick is not to pour the water on the plaster, but to turn the latter gradually into the water, spreading it about in shaking it in, and to avoid stirring until all the plaster has been added. The proper quantity of gypsum is usually enough to peep out over the surface of the water over the greater part of the area; that is, about equal volumes of each ingredient. The addition of glue-water to the mixture retards setting.

Working Aluminum.—Aluminium is not worked as often as steel, wrought iron, cast iron or brass, and the average machinist does not know how to machine it. On all cutting except tapping, work the metal dry. Aluminium, like other cast metals, is lifeless; that is, long curling shavings cannot be taken off as with steel, but rather a shower of small chips as in cutting cast brass.

The metal is easily torn, especially in thread cutting in the lathe, where if not careful, the tool will dig in and tear out rough threads. In making fine, smooth threads, take several light finishing cuts. For a nice surface finish, either in a lathe or planer, use a broad tool, but with a light cut, and employ the same caution as in thread-cutting to prevent digging and tearing the metal. Aluminium can be cut as fast as brass.

Steam Tight Joints.—Take white lead ground in oil, add to it as much black oxide of manganese as possible and a small portion of litharge. Knead with the hand, dusting the board with red lead. The mass is made into a small roll and screwed or pressed into position, the joint being first slightly oiled with linseed oil.

To Waterproof Leather.—To waterproof leather and leave it soft and pliable, apply a mixture of 4 parts castor oil and 1 part raw india rubber, by weight. Heat the oil to 250 degrees F., then add the rubber, cut into small pieces. Gradually stir until the rubber is completely dissolved and then pour into a suitable vessel and let cool. If used on dark leather add sufficient printer's ink to give the dark color.

To Remove Hard Grease, Paint, Etc.—To remove grease, paint, etc., from machinery add half a pound of caustic soda to two gallons of water and boil the parts to be cleaned in the fluid. It is possible to use it several times before its strength is exhausted.

Lubricating Oil Mixed for Winter Use.—Graphite mixed with cylinder oil until the mass is of the consistency of paste, and then reduced with kerosene until it flows freely, is recommended by an engineering authority for outdoor use in winter where lubricating oil is required. It is claimed that this compound will not stiffen at a temperature of 14° below zero.

“Tailor Made” Bodies of Grace and Individuality

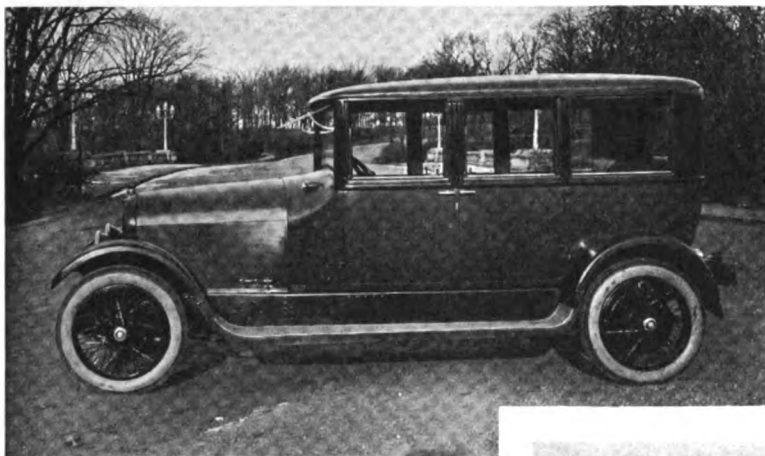
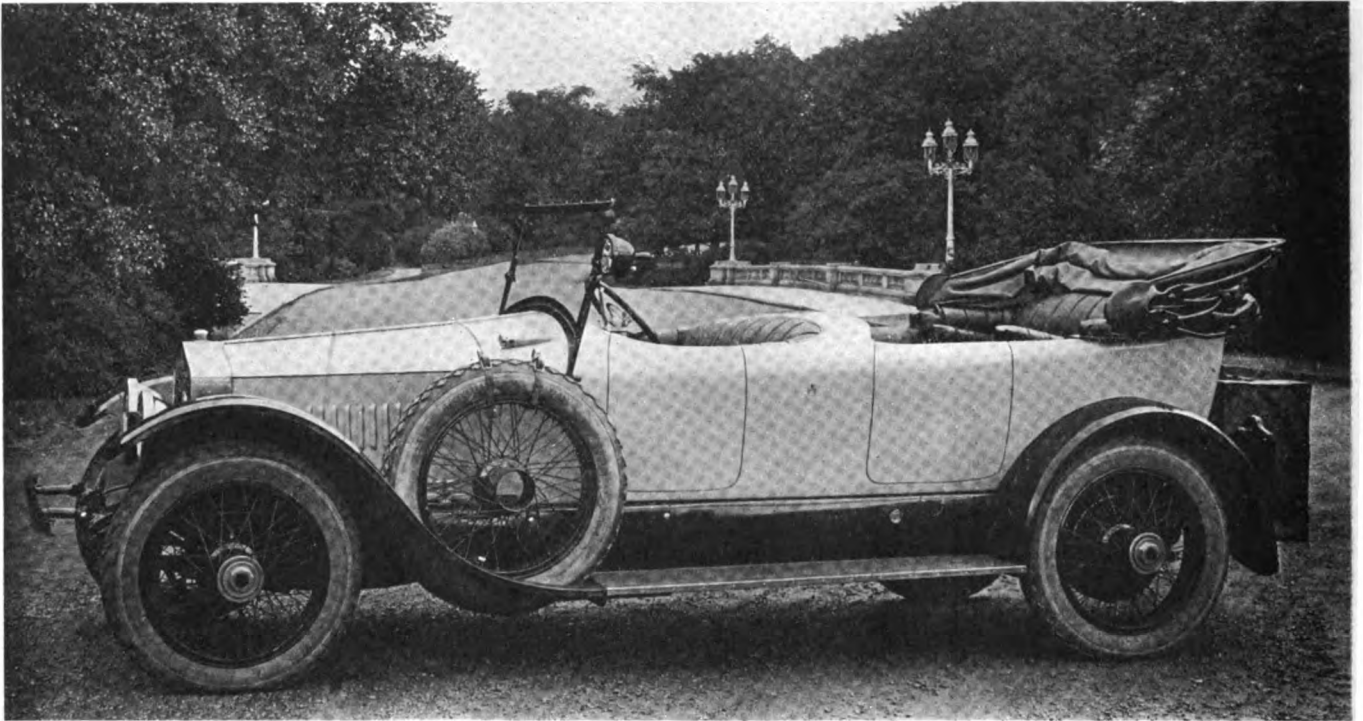

The automobile shown above is a regular Cadillac chassis. The Wheelbase has been extended nine inches, giving it a wheelbase of 141 inches. The mud guards, tire carrier, Rolls-Royce type radiator, headlights, top and trunk rack were all specially built to meet individual requirements

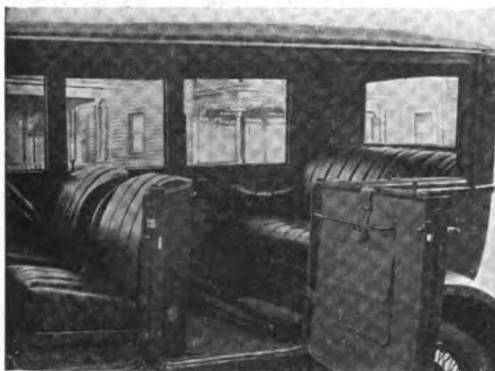

*Limousine Built to Order.
Below—Detail of interior upholstered
in Spanish leather*

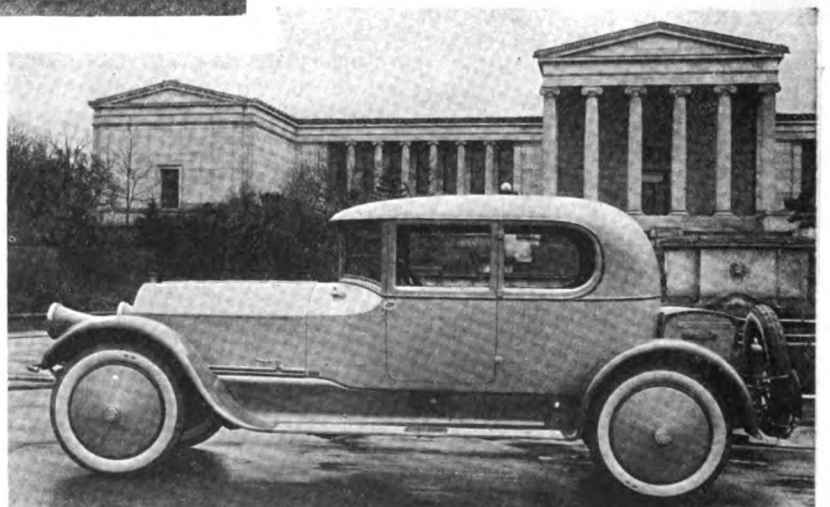

Specially Constructed Car of Glenn H. Curtiss, the Famous Aviator

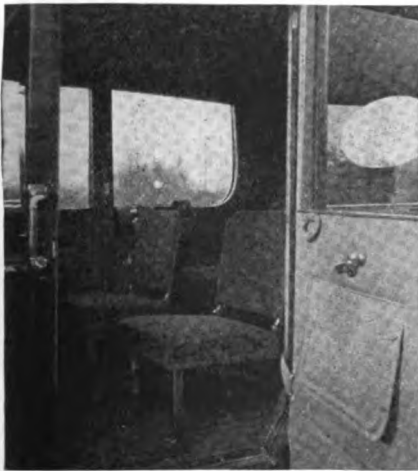

Beautifully decorated Interior

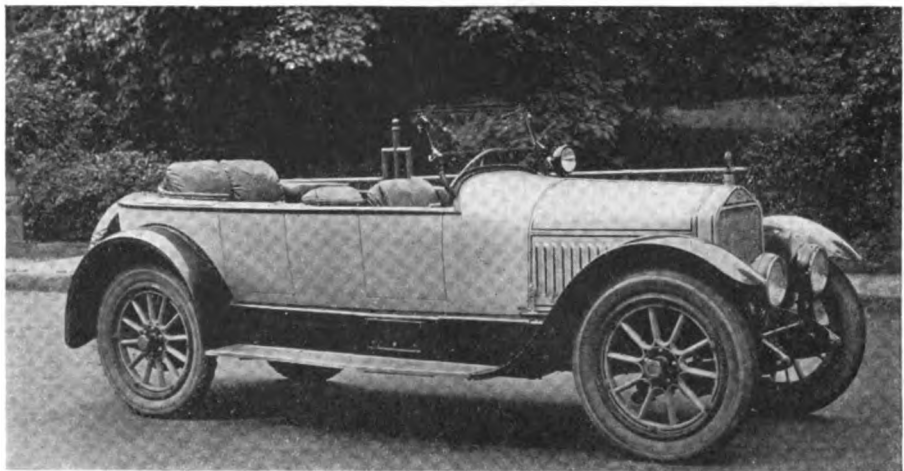

Nautical type body on White Chassis

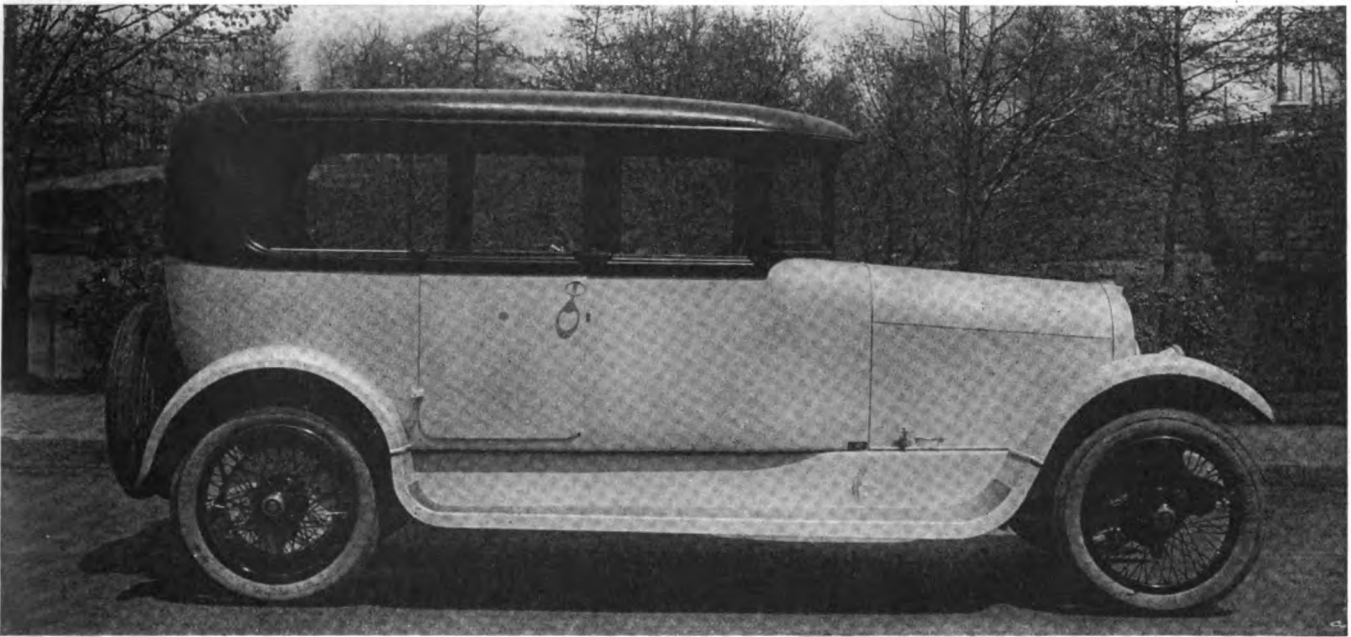

The transformable body permits use of car as limousine or touring car

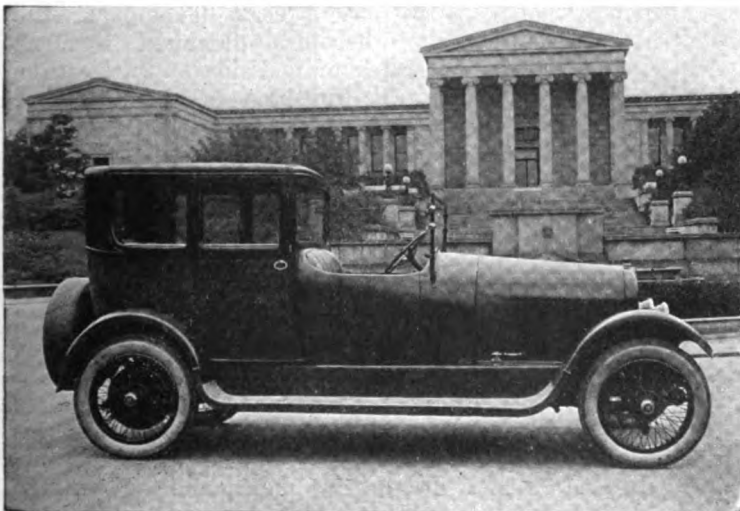

Town car of latest modern design

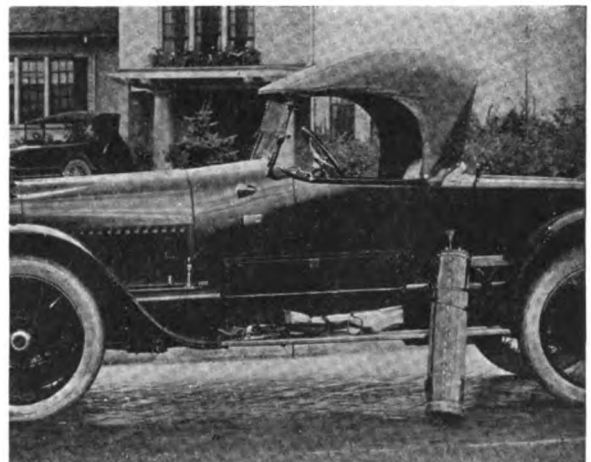

Roadster built to order with special compartment for carrying golf clubs, etc.

Tubular Radiators and Their Repair

S. P. BRINKER

Illustrations by courtesy of McCord Mfg. Co., Detroit, Mich

BY common consent, it appears that truck and tractor manufacturers have decided that the tubular type of radiator answers the purpose better than any other form and this form or radiator in its numerous variations is generally considered standard for truck and tractor service.

This type of radiator has been found most satisfactory for passenger cars as well as for truck and tractor service because it stands up better and has proven more dependable than any other type of tubular or cellular radiator now in general use.

Cellular radiators are open to the serious objection that the water space between the cells is very small. Then too, the fact that very little misuse will start more or

less serious leaks make this construction a more or less constant source of trouble by clogging and leaking and the difficulty in making repairs necessitated by freezing or accident.

As regards cooling capacity, the fin and tube type of radiator construction shown in Fig. 1 will dissipate as much heat per cubic inch of core or per pound of copper, as the most efficient radiator of the cellular type and more than many forms of tubular radiators.

The cooling element consists of straight rows of vertical tubes, one quarter of an inch in diameter and spaced one inch apart across the front and one half an inch apart from front to back. The fins or plates, in the best practice, are re-enforced copper or brass sheets forced over the tubes and each tube thoroughly soldered to each fin so

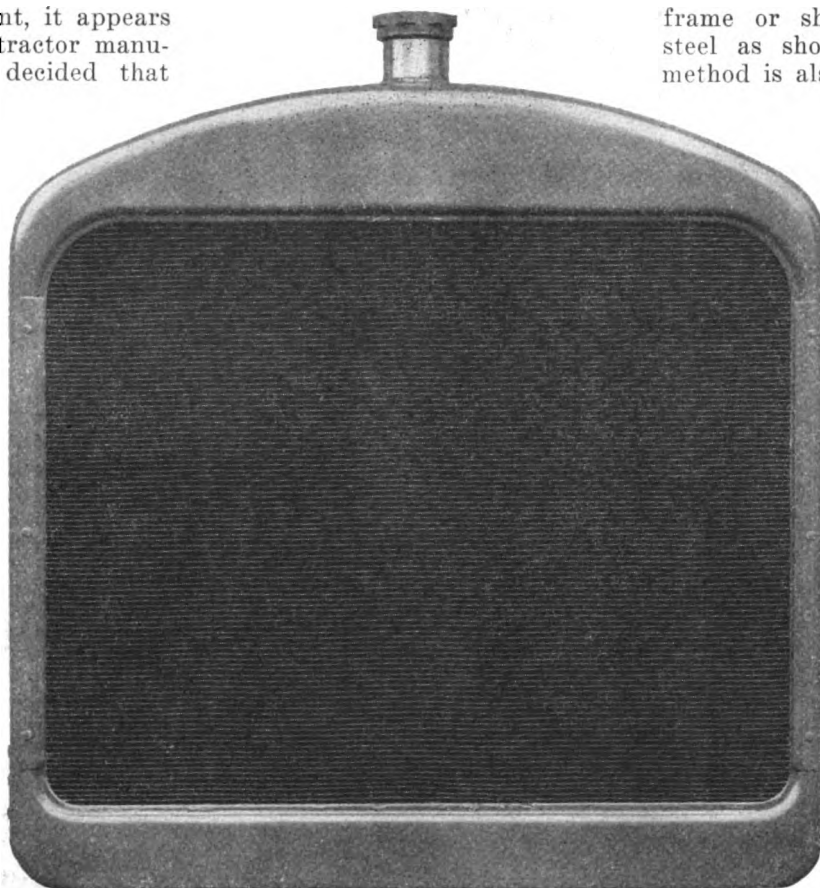

Fig. 1.

Tubular radiators of this type are making their appearance more generally on high class passenger cars. They are also widely used on trucks having pneumatic tires.

that perfect mechanical and heat conduction joints are made. Over the ends of the tubes, the head sheets are tightly fitted by means of re-enforcing ferules and the joints closed by rings of high grade solder. The cooling elements in this shape then consists of vertical columns tied together laterally in every direction by the plates that are spaced one sixth or one seventh of an inch apart. The best makes of tubular radiators have the insides of the tubes heavily coated with high grade tin so that failures or leaks from corrosion or the use of impure water are eliminated. The water passages are long and straight and the air openings unobstructed. For passenger car use, the cooling element is usually assembled with brass or copper top and bottom tanks or headers and the integral parts supported in a

frame or shell made of pressed steel as shown in Fig. 1. This method is also followed quite generally on radiators for trucks equipped with pneumatic tires.

The usual and most substantial method of mounting the radiators on heavy trucks and tractors is shown in Fig. 2. In this construction the top and bottom tanks are made of cast iron, aluminum or pressed steel, bolted to side members or spacers, the assembled sections forming a rugged frame or cradle in which the core is supported. It will be noted that the removal of the core or cooling element is a very simple and easy operation and when the radiator is dismantled, the top and bottom ends of the tubes are exposed and any tube can be

opened up or cleaned out by the insertion of a 3-16 inch rod or washed out with a hose.

In case a leak develops or the core becomes damaged through freezing or collision an entire tube can be removed in the following manner:

Cut a piece of 3-16 inch rod about eight inches longer than the tube, bend the end of the rod at right angles to form a handle or lever. Thoroughly tin this rod throughout its length and insert hot into the tube to be washed. The tube will then be soldered to the rod. Then with a blow torch, loosen the fins and head sheets about the damaged tube and turn the tube during this operation by means of the handle on the rod mentioned. When the tube has been loosened entirely it can be removed through the head sheet. A new tube can then be in-

serted and soldered to the fins and both head sheets.

It is also possible to cut out of the core a small section and make repairs by expanding the ends of the old tubes slightly so that short pieces of new tubing can be telescoped into place and soldered, the fins can then be notched with snips, slipped back into place and soldered. When such repairs are made, the radiator is in the same condition as far as capacity is concerned, as when new. Fig. 3 shows an enlarged view of this type of construction.

HELPING THE CRIPPLED SOLDIER

In other wars it was the practice to discharge from the hospitals into civil life the industrially incapacitated soldiers, to become a burden on society, on their families and to themselves. By act of Congress the Federal Board for Vocational Education has been endowed with full powers to take over the disabled soldier and sailor, regardless of whether the disability was caused by battle or disease, when he is about to be discharged from the hospital and to fit him mentally and physically, as far as may be, to become once more a contented and independent member of our social and industrial life.

But no man can be forced to take advantage of our Government's wise and humane provision. It is up to him and even more vitally up to society at large, as we shall presently point out.

The Federal Board is empowered to pay a disabled man a minimum wage of \$65 a month during the period of re-education, with proportionately more if he is married and has children. There are fourteen centers, spread out over our country, so that each man may be somewhere near his home town and his family. Experts in every known occupation will be available. A two-

armed man, who before the war earned two dollars a day **from the neck down**, in many cases will be taught, as a one-armed man, to earn much more **from the neck up**. In short, a large proportion of our disabled fighters can and will be restored to economic independence and to peace of mind.

Just how large a proportion will depend on the attitude of the public. The kindly but thoughtless citizen will say: "Too much cannot be done for our disabled heroes," which is true only if **right things** be done; for this is a delicate psychical problem.

Our Allies have found that rarely does a disabled soldier volunteer for re-education; it only comes about through the force of public opinion and the tactful influence of his intimates. It is therefore the attitude of this man's family, friends and home-town acquaintances that will determine his future in nine cases out of ten; and his future, socially and economically, is a vital part of America's future, and a gauge of our civilization.

This man wants sympathy, but not **pity**; this man needs to be treated as a human being, not as an abnormality. To be feted as a hero for a month and then forgotten has been the fate of many already

and will be the ruination of more. The disabled man goes through wave after wave of desperate depression, dwells poignantly on all things he could once do and can no longer do—so he thinks. If his friends make him believe that what he has suffered for his country entitles him to a life of idleness they

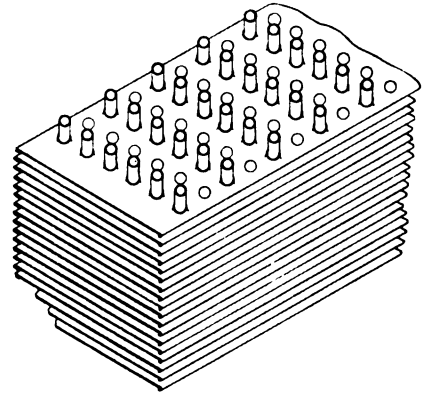

Fig. 3.

have done the worst thing possible for the man himself. We have seen too many Civil War victims peddling lead pencils to believe that attitude either wise or humane.

After his discharge from the hospital it is the natural course that the man should go home for a visit before the vocational expert calls on him to advise with him on his re-education. During this interim it is the duty

of the public generally and his friends in particular to lift him up to the normal plane, spiritually and mentally by making him forget his disabilities, not by pointing to them.

We should be cheerfully matter-of-fact in our constructive kindness. His very life may depend on making him feel that he is still one of us and not an object forever set apart by the ravages of war. We must not kill him with thoughtless kindness, but help him with kindly thoughtfulness and make it as easy Government to as we can for the carry on its great work of helping these men to help themselves.

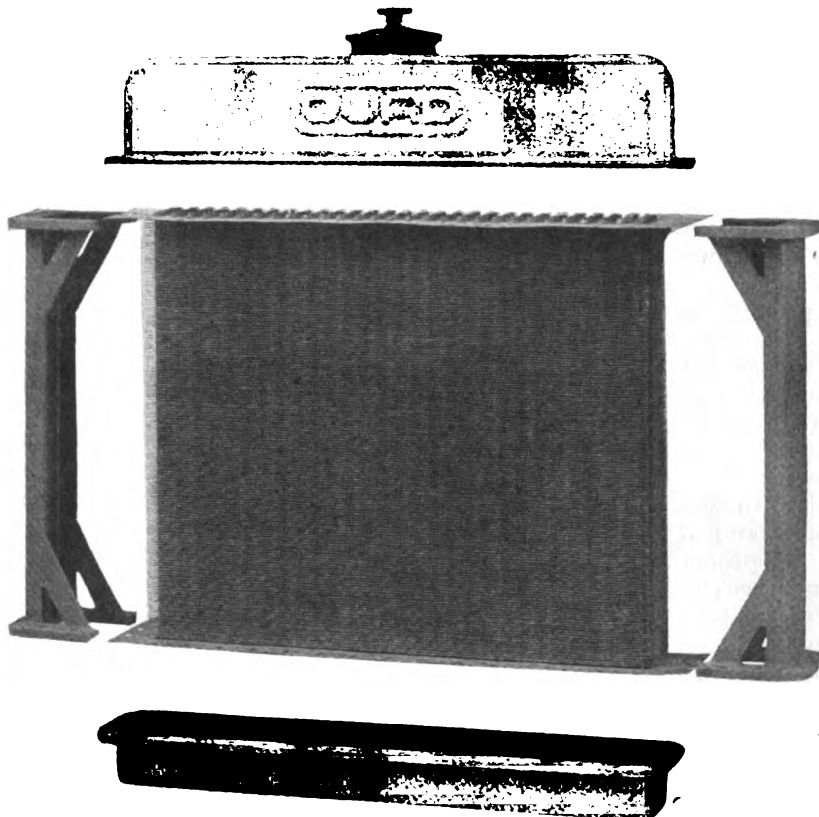

Fig. 2.

McCord tubular radiator that is easily disassembled for cleaning and repairs that is the standard design for heavy trucks and tractors.

SHOP MANAGEMENT

"Old Timer"

There was a time once when 75 per cent of our customers paid their bills once a year, as they were all stockmen and paid when they shipped. Alas, for the good old days. Things certainly have changed in the last 15 years. There are as many cattle but more men and these men raise more hogs, sheep and grain. They sell oftener and in smaller quantities and thus collections are made easier than under the old arrangement.

When we see some of our slow customers coming into town with a load of hogs or grain or driving a bunch of cattle to the stockyards, we make it a point to see him at once and in nine cases out of ten we land him for all or part of the bill.

The average man feels richer just after he has made a good deal than he ordinarily does, naturally he is feeling rather good and is easily approached.

An account may be opened in the spring as the farmer puts in his crops and may run until fall, but not as a rule, as the farmer generally has something that he is turning off long before that time.

The shop owner should get a "line" on his customers just the same as the wholesale house keeps track of him. The wholesaler goes to a commercial agency for information and the shop owner can get his information easily enough from the banks, the merchants and even the farmers themselves will be willing to tell what they know about the willingness of Jones or Brown or Robinson to pay their bills.

If the customer is prompt in meeting his obligations the shop owner is thereby able to pay his own bills in a like manner and his rating in Dun or Bradstreet will be A-1.

One fifth of the shop owners' success depends on his ability to buy his goods at the right price and of the right quality and in proper quantity. There is a much heavier demand for some kinds of stock or certain supplies at different seasons of the year and it is a bad plan to tie up money, we will say by stocking up on toe calks, etc., and have this lay idle until snow comes next winter.

Buy often and close and see that you don't have any gold bricks laying around that you will eventually have to throw on the scrap pile.

Buy from some good reliable house colse to you and in this way you will get good and reliable service. The main thing is to keep your credit good with the man you buy from and if you don't insist that your customers keep their credit good with you then your own standing will not last long.

YOUR FAMILY'S HERITAGE?

Two days before Christmas we received the letter from which this paragraph is quoted:

"I am left three little children, a blacksmith shop, some debts and some very bad bills."

The following day we received a somewhat similar letter quoted below:

"My husband subscribed for your paper in October for two years but he died on November 4, so I am writing you about it as I saw a card you sent to him stating that in case of death you would return the money to the widow. Please let me hear from you at once as we don't need the paper any longer and do need the money."

A part of this story is the fact that a check for the amount was promptly and gladly sent the writer of the letter, but the main idea is: "What would your family do if you were to be taken from them?" You can answer that question to your own satisfaction.

Did it ever occur to you that poor prices, long credits that develop into bad accounts and other violations of first business principles is robbing your family of that peace of mind for the future and the advantages of the present that they have a right to enjoy?

"ANTI FREEZE" SOLUTIONS

J. L. Haky

THREE common materials form the principal if not the entire composition of most if not all the anti freeze preparations on the market to prevent the freezing of automobile radiators — Calcium Chloride, Alcohol and Glycerine.

Calcium chloride is sold (never by its own name) by various concerns in five or ten pound packages at about twice the cost your druggist will get it for you. Calcium chloride comes in the form of a powder and is dissolved in water in the proportion of 3¾ pounds of chloride to a gallon of water for protection against temperatures down to zero and a mixture of 4 pounds of the chloride to a gallon of water will protect to 17 degrees below zero.

Chemically pure calcium chloride should be used, as in the commer-

cial article there is more or less free acid that will attack the metal parts that it comes into contact with. To be absolutely certain that the calcium chloride you get is neutral test it with blue litmus paper that can be obtained from any druggist for a few cents. The slightest trace of acid will cause it to turn blue. If you find traces of acid, add ammonia or soda ash until the litmus no longer turns blue.

use of glycerine, provided it is obtainable at all at this time, hence nothin g further will be mentioned in this article on the use of this substance.

Both wood and denatured alcohol are extensively used to prevent radiator freezing and it makes little difference which is used. Wood alcohol has a lower freezing point than the denatured and is preferable for that reason and from the fact that less of it is required. Wood alcohol evaporates somewhat more rapidly than denatured alcohol and consequently it is necessary to add to the alcohol almost daily. The fact that the denatured alcohol evaporates less rapidly makes it preferable for radiator anti freeze solutions. There is also one danger that exists where wood alcohol is used and that is the formation of an inflammable vapor that comes out of the overflow pipe and is likely to catch fire from a spark or flame.

The proper mixtures of alcohol and water are as follows: 10 degrees above zero — Water 80%, Alcohol 20%, Zero—75% water, 25% Alcohol, Specific Gravity. 969 —7 degrees—Water 70%, Alcohol 30. Spec. Gravity .963—22 degrees —Water 60% alcohol 40%. Specific Gravity .951.

When denatured alcohol is used increase the percentage of the above by approximately 15%.

For evaporation use 75% alcohol to 25% water, as the alcohol evaporates quicker. This does not apply, of course, to leaks or overheating.

A hydrometer can be used for mixing and maintaining correct solution by first testing the original and keeping it up to standard.

Kerosene is often used by people who ought to know better, to keep their radiators from freezing. Kerosene will prevent freezing, that much is admitted but the objections to it for this purpose are many.

A car loaded up with kerosene in its cooling system makes people begin to sniff around and wonder what's dead in the neighborhood; when heated it evaporates and is liable to ignite if near a flame; it has a tendency to cause overheating on warm days, it rots the radiator tubing and deposits a greasy mist over the car. Gas is also likely to form and bulge or burst the radiator which would be about as bad as letting it freeze in the first place.

Now we come to the interesting question—which is the best and least bothersome mixture to use?

If you use sodium chloride you needn't worry any about the strength of your solution as this salt does not evaporate and consequently about the only attention required is to keep the radiator filled, although it might be well to add some additional calcium chloride from time to time—always bearing in mind that you should use the chemically pure salt.

The alcohols are generally more easy to obtain than the calcium chloride and are preferred by many despite the fact that frequent auditions have to be made to their strength to keep them from freezing (the taste for alcohol, that an automobile will acquire is astonishing and temperance societies are considering the introduction of prohibitory legislation).

Now, we come to the main show—the three ring circus so to speak. Just as circus performers are known to the "profession" by names that compel one to think of the names on Pullman cars and the names of Kansas towns, so do we meet our old friends that we have just been discussing on the market in cans and boxes under strange names and selling at prices that make them wonder why they ever left home.

MOUNTING EMERY CLOTH

In most of the jobs where emery cloth is used it is far better to have the cloth attached to a stick, which is used like a file, than to merely hold in the hand. A few sticks, shaped like large files, with strips of emery glued to both surfaces, will be of great service; the work will be more satisfactory and there will be a real saving in emery cloth. A well worn piece of cloth is excellent for fine finishing. By this system better finishing can be done on flat surfaces.

Bringing the Trucks Back From the Front

JOHN Y. DUNLOP

Britishers wonder what will happen when their government brings its thousands of motor trucks, passenger cars, tractors and other equipment back from the front—Nobody, apparently knows, but the guessing is open to all comers.

DISPOSAL of the great number of government owned motor vehicles that are returning from the front or that will eventually be returned or otherwise released from active service is a question that continues to agitate certain circles.

The thought is dreaded by some that the government intends putting up thousands of these vehicles for sale and it is of course contended by interested parties that such a policy would have a detrimental effect on the future development of motor traction.

It is further urged that people buying such machines under such a policy would discover faults created by the rough usage to which they have been subjected in service and will rightly or wrongly set down these faults and consequent failures to defective work on the part of the manufacturer.

In this way some makers may be prejudiced toward the possessors of faulty makes of machines with the result that they will withdraw their patronage and in some cases it might even lead the user from motor haulage back to horses.

These arguments may seem to be quite reasonable at first blush but the man who will buy a motor lorry at junk price and expect to get good service from it is not what one generally considers when he thinks of a business man.

Anyone of common prudence buying a piece of machinery of any kind at auction will be careful to have it examined by an expert before parting with his money.

Regarding the chances of diverting people from motors to horses a prominent personality put the matter in a more likely form when he stated that it was to the ultimate benefit of all concerned that as many as possible should possess motor vehicles whether they be good, bad or indifferent as the advantages thus gained would teach

conclusively the advantages of mechanical haulage.

Another question that is causing certain of the small English manufacturers to lie awake nights is whether the pre-war relation of coachbuilder and engineer will come to exist again. In those days they flourished side by side and were mutually cooperative, the former making the body and the latter providing the chassis and other mechanical parts.

It is not intended that these remarks should imply that this division of labor was general throughout the trade for the biggest concerns built their own bodies as well as their own chassis but the practice mentioned was very common and no particular complaint was ever directed in its direction. As a matter of fact such a system has certain manifest advantages.

So far as can be ascertained, few British firms have been able to define their post-war policy as the most of them have been very busy getting clear of existing government work.

One or two manufacturers have permitted it to become known that they intend concentrating their energies on fewer models than they turned out previously but as to the extent of the response to the invitation by the Motor Industry Branch Committee to disclose programs with a view to the release of material for experimental purposes very little is publicly known.

It is safe to assume, as suggested that the trade has not yet generally arrived at a course of action following the end of the war and consequently the action on the question of the making of bodies by the chassis builders may be regarded as unsettled.

So far as an opinion may be hazarded in England, it is that the probabilities lie in the direction of greater concern in the engineering factories.

The resumption of motor manufacturing may witness combinations with the view of avoiding needless competition and duplication of effort in particular models and combination of interests in this way may be followed by a more general adoption of the policy of producing everything possible inside the factory.

With these changes we must have education along broader lines than in the past.

The reason I make this statement is because that I am convinced that what a friend of mine has said is true.

This friend lived in a suburban cottage which was supplied with water drawn from a deep well by a windmill. The supply had just stopped and let the wind blow as it could up there and the wheel run until it rattled there was nary a drop of water—something inside had gone wrong.

Now, he says "If I had been taught just as much plumbing as I

had been about logarims I would have been able to diagnose the trouble in a few minutes. As it was, I had to find my way around to all the plumbers' shops before I could get their opinion as to what would likely be wrong. When they did find time to get there and make their examination, all that was wrong was a new leather bucket, the one that had seen six years of hard work having worn out."

We want and need a change educationally if we are going to run our own cars for it is absolutely necessary for every one of us to understand the rudiments of mechanics. Call it a branch of engineering if you like. Certainly, it sounds more imposing but I have observed that superior plumbers always describe themselves on their business stationery as "engineers."

A little knowledge would save a lot of temper and even money and it would be a very long step in the complete knowledge of the automobilist.

There are other applications of heat, both electrically and from exhaust gases, by means of water jacketed carburetors and other arrangements of a similar character, but the heated inlet manifold has proven to be about the most efficient and least troublesome method of increasing engine efficiency by heating the fuel.

There are all sorts of compounds and preparations on the market to be mixed with the gasoline "to make it go farther". Some of these preparations are what one might term pure fakes and if you get a whiff of others you will be able to recognize them for what they are—the old familiar mothball. Then too, there's the preparations made of picric acid, high test gasoline, ether or chloroform or having these ingredients in them in larger or smaller quantities, also more or less coloring matter. Picric acid will give power to an engine, no one will dispute the fact, but—it will damage the cylinders and pistons that it comes into contact with by corroding them. The other preparations are harmless and more or less useless. The only way in which one can get anything out of such compounds is when the manufacturer will guarantee the preparation unconditionally and refund your money if unsatisfactory.

Another development of the comparative scarcity and high cost of gasoline is the kerosene carburetor. In view of the situation, developments along this line have progressed rapidly within a short period and now there are on the market carburetors that give excellent results. Different styles of kerosene carburetors are designed to work on mixtures of kerosene and gasoline in various proportions or all kerosene. In this connection, it would be wise to use considerable caution in the purchase of a kerosene burning carburetor as there are a number of such devices on the market of poor design.

Often the car owners who considers the replacing of his old carburetor for a new one of another make only needs the old one re-adjusted or, possibly a new part. Automobile manufacturers spend a great deal of money in selecting carburetors for their cars that will give the best possible results from the fuel and while there may be other carburetors that would give better results it is best to make certain before making such changes.

Devices for Economizing Fuel

HUGO FRANKLIN

Before you put on a new Carburetor or any of the other arrangements or preparations for getting more miles out of a gallon or putting more "pep" into the motor give this article the "once over."

The memory of recent gasless Sundays is still sufficiently strong in our minds to make us realize that every possible saving must be effected in the consumption of gasoline, even if the war is over. In the past a large number of devices have made their appearance on the market with all manner of claims made for them and having as their primary object reduction in operating costs for fuel.

One of these devices is in the form of an auxiliary air attachment. The idea underlying all devices of this character is the admission of more air into the gasoline mixture. These devices may be either automatic or hand controlled from the dash or some other part of the car.

Now, if the sole function of de-

vices of this class is to simply furnish more air to the carburetor, it stands to reason that this same object could be attained by regulating the carburetor. The earlier forms of carburetors had not sufficient range of adjustment and in these auxiliary air attachments served a useful purpose. Modern engines have carburetors that have been selected with due regard to the engine they operate and the present quality of fuel and the use of an auxiliary air attachment is more or less of a gamble.

Within a comparatively few months the heated manifolds that have made their appearance under various trade names have become to be quite popular and for them it may be said that they are devices of considerable merit. Motorists are familiar with the present grade of fuel they get and even the present day carburetors have more or less difficulty in handling it. The heated intake manifold breaks up and vaporizes the fuel in such a satisfactory manner that it finds its way into the cylinder in a condition to be easily ignited and furnish the maximum power.

Glossary of Storage Battery Repair Terms

- Acid:** Term frequently used to describe the liquid in cells, in place of the more correct one—**Electrolyte**.
- Active Material:** The "formed" paste which fills the grid.
- Ampere:** The unit of measure of quantity of electric current.
- Ampere-Hours:** Product of amperes and hours.
- Battery:** Any number of cells when connected and used together.
- Bridge (or rib):** Wedge-shaped vertical projection from bottom of rubber jar on which plates rest and by which they are supported.
- Burning:** A term used to describe the operation of joining two pieces of lead by melting them at practically the same instant so they may run together as one continuous piece. Usually done with mixture of oxygen and hydrogen gases, hydrogen and compressed air, or oxygen and illuminating gas.
- Cadmium:** A metal used in about the shape of a pencil for obtaining voltage of positive or negative plates. It is dipped in the electrolyte but not allowed to come in contact with plates.
- Capacity:** The rating of cell or battery in ampere-hours, qualified by the rate or time of discharge.
- Case:** The box which holds the cells of a battery.
- Cell:** Unit of storage battery practice; consists of element, electrolyte and jar.
- Charge:** Passing direct current through a battery, in order to replace energy used on discharge.
- Charging Rate:** The proper rate of current, expressed in amperes, to use in charging a battery.
- Connector:** Solid or flexible part for connecting positive pole of one cell to negative pole of another, etc., or to terminal.
- Cover:** Cover for cell to retain electrolyte and exclude foreign material.
- Cycle:** One charge and discharge.
- Density:** Specific gravity.
- Developing:** The first cycle or cycles of a new or rebuilt battery to bring about electro-chemical conditions to give rated capacity.
- Diffusion:** Pertaining to movement of acid within the pores of plates. (See **Equalization**.)
- Discharge:** The flow of current from a battery through a circuit, opposite of "charge."
- Dry:** Term frequently applied to cell containing insufficient electrolyte.
- Electrolyte:** The conducting fluid of electro-chemical devices; for lead-acid storage batteries consists of about two parts of water to one of chemically pure sulphuric acid, by weight.
- Element:** Positive group, negative group and separators.
- Equalization:** The result of circulation and diffusion within the cell which accompanies charge and discharge. Difference in capacity at various rates is caused by the time required for this feature.
- Equalizing:** Term used to describe the making uniform of varying specific gravities in different cells, of the same battery, by adding or removing water or electrolyte.
- Evaporation:** Loss of water from electrolyte from heat or charging.
- Forming:** Electro-chemical process of making pasted grid or other plate types into storage battery plates. (Often confused with **Developing**.)
- Foreign material:** Objectionable substances.
- Freshening Charge:** A charge given to a battery which has been standing idle, to keep it fully charged.
- Gassing:** The giving off of oxygen gas at positive plates and hydrogen at negatives, which begins when charge is something more than half-completed—depending on the rate.
- Gravity:** Common term for specific gravity.
- Grid:** Cast or stamped framework in which active material is retained.
- Group:** Any number of positive or negative plates properly joined together.
- Hold-down:** Device for keeping separators from floating or working up.
- Jar:** Container for element and electrolyte. Usually of hard rubber.
- Lug:** Vertical projection from grid for connecting with and burning to strap.
- Mud:** (See **Sediment**.)
- Over - Charge:** Continuance of charge beyond that apparently or supposedly necessary to improve conditions of cells.
- Over-Discharge:** The carrying of discharge beyond proper cell voltage; shortens life if carried far enough and done frequently.
- Paste:** The mixture of lead oxide or spongy lead and other substances which is put into grids.
- Plate:** The combination of grid and paste properly "formed." Positives are reddish brown and negatives slate gray.
- Polarity:** An electrical condition. The positive terminal (or pole) of a cell or battery or electrical circuit is said to have positive polarity; the negative, negative polarity.
- Post:** The vertical cylindrical part of strap which receives connector.
- Potential Difference:** Abbreviated P.D. Found on test curves. Synonymous with voltage.
- Rate:** Number of amperes for charge or discharge. Also used to express time for either.
- Rib:** (See **Bridge**.)
- Ribbed:** (See **Separator**.)
- Reversal:** That which occurs to voltage readings when cells are discharged below a certain critical point or charged in the wrong direction.
- Sealing:** Making tight joints between jar and cover; usually with a black, thick, acid-proof compound.
- Sediment:** Loosened or worn out particles of active material fallen to the bottom of cells; frequently called "mud."
- Sediment Space:** That part of jar between bottom and top of bridge.
- Separator:** An insulator between plates of opposite polarity; usually of wood, rubber or combination of both. Separators are generally corrugated or ribbed to insure proper distance between plates and to avoid too great displacement of electrolyte.
- Spray:** Fine particles of electrolyte carried up from the surface by gas bubbles. (See **Gassing**.)
- Strap:** That part to which all plates of one group are burned.
- Sulphate:** Common term for lead sulphate. (Pb SO₄.)
- Sulphated:** Term used to describe cells in an under-charged condition, from either over-charging without corresponding long charges or from standing idle

some time and being self-discharged.

Sulphate Reading: A peculiarity of cell voltage when plates are considerably sulphated, where charging voltage shows abnormally high figures before dropping gradually to normal charging voltage.

Terminal: Part to which outside wires are connected.

Vent or Vent-Cap: Hard or soft rubber part inserted in cover to retain atmospheric pressure within the cell, while preventing loss of electrolyte from spray.

Voltage: Electrical pressure or potential difference, expressed in volts.

Wall: Jar sides and ends.

Washing: Removal of sediment from cells after taking out elements; usually accompanied by rinsing of groups, replacement of wood separators and renewal of electrolyte.

Watts: Product of amperes and volts.

Watt-Hours:—Product of amperes, volts and time in hours.

RURAL MOTOR EXPRESS

Farmers throughout the country will have in use 300,000 trucks by the end of this year and, according to estimates, will retire 1,200,000 horses. Every horse displaced means five more acres of land that can be devoted to raising food for human beings. Colorado in 1917 had 325,000 horses. The war and the advent of the motor truck has probably reduced this number. Take as a conservative estimate 200,000 horses used on farms or in transportation, which, replaced by motor trucks, would mean the use of 1,000,000 acres needed to support the animals for raising food.

Several transportation companies already have incorporated and are trying out the new idea of making regular trips daily between towns situated from thirty to fifty miles apart. One of the most recent incorporations is controlled by a group of dairymen from Castle Rock who have combined their business opportunities with the general advance of economic distribution of farm products in general. The company has several trucks that make regular trips to Denver, a distance of thirty-two miles, bringing to the metropolis dairy products and returning with a load of small wares to be dropped at towns along the way.

FORD CRANK CASE SUPPORTS

A common source of trouble on Ford engines is the breakage of

the crank case supports, particularly the side supports.

It is hardly possible for the mechanic to make either of the parts as economically as they can be purchased but when repairs or alterations are required the accompanying drawings will be found of much value.

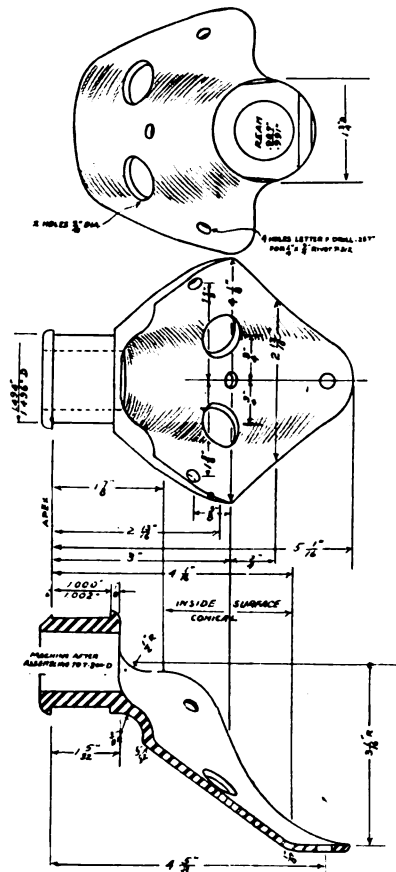

FORD CRANK CASE SUPPORT—SIDE

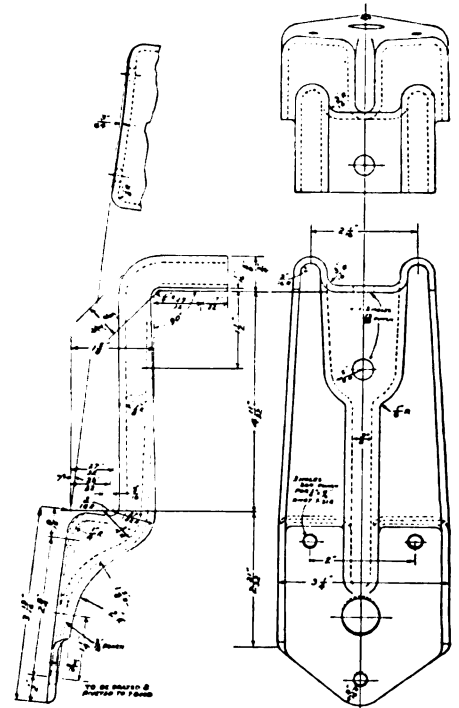

FORD CRANK CASE SUPPORT—FRONT

This practice developed through the extension of the suburban motor traffic, and more generally, perhaps, because of the congested conditions of railroad freight traffic due to war shipments.

Fruit, vegetables, milk and eggs arrive in market or direct to the door of the consumer fresh and desirable on the day they leave the farm and command the highest market prices. It is regarded by agricultural experts as the most encouraging and potent indication to the farmer that no matter what his production, his produce will find a speedy way to market.

MODERN COLD CHISELS

E. M. Peterson

In large shops where many cold chisels are used it has been proven again and again that these essential tools cannot be made too good, more often they are not made good enough.

I have found that the most efficient chisel is made of $\frac{3}{4}$ inch

octagon No. 7 Colonial steel. The bars are cut into 7.5 or 8 inch lengths and the head is swaged up and the flat end drawn out. The half round chisel is similarly made only the cutting end is swaged half-

After the chisels have been forged and formed in this manner they are placed in a heat treating furnace and heated from 1,500 to 1,700 degrees and are oil hardened. The heat in the furnace allowed to drop to about 700 or 800 degrees and the tools "soak" at this temperature for about a half hour before they are quenched and hardened. This treatment gives good results or, a bath of saltpeter at a temperature of about 900 degrees will give equally satisfactory results. After the tools have been permitted to remain in the hot saltpeter for about 20 minutes they are removed and sent to the grinder after which they are tempered and drawn to yellow or dark straw color as the case demands and the tools are sent to the tool room for distribution.

SHOEING REFRACTORY HORSES.

In the department of equitation at the Mounted Service School the following method is used with young horses that are disposed to kick when their hind legs are first handled. The horse is equipped with a cavesson, which is held by the animal's trainer. A surcingle is placed around the girth. The man that grooms the horse takes hold of the surcingle with the inside hand, in order to move with the horse and be secure against injury. With the outside hand he strokes the haunches and legs, gradually working downward. In the meantime the trainer pats the horse on the neck, but corrects him sharply with the cavesson whenever he displays temper. This method is almost invariably successful.

The second step is to let the young horse grow accustomed to the shop. While the horseshoer is at work on a quiet horse the young horse should be led into the shop and held by the man who has been grooming him and raising his feet.

The animal should not be tied, nor should he be held by any other man than the one he knows and trusts.

When the animal shows neither timidity or excitement the shoer begins work on the feet. Frequently the removal of the surplus growth of horn is all that can be accomplished without excitement or resistance. At the first sign of either, work for that day should be abandoned and the horse removed from the shop.

The shock of the hammer is conveyed to the joints of the pastern bones, and the green horse, startled thereby, will struggle to free his foot. The shoer can usually handle a forefoot easily unassisted. If a good helper holds the hind leg in a comfortable position on his thigh and holds the hoof firmly with both hands the shoer can work with more certainty, the shocks of the nail driving will be taken up, to a great extent, in the helper's wrists and arms, and the horse will stand quietly.

Patient, quiet work will eventually succeed and thereafter each shoeing is more easily accomplished.

There are, however, certain highly nervous horses in nearly every organization that are refractory as a result of previous bad hand-

ing, and in the emergencies of active service there may be insufficient time to quietly prepare new mounts for shoeing as explained above.

In these cases some form of restraint is required, but in each instance no more force should be employed than is absolutely necessary—the gentlest method should be tried first.

The cavesson, as a means of correction, will usually make a horse stand still and is to be preferred to the twitch. The latter, although effective, is a brutal instrument, and should never be used except upon an outlaw; moreover, after repeated use of the twitch the horse dreads any approach of the hands to his muzzle, and can be bridled only with the greatest difficulty. Severe use of the twitch will also permanently disfigure the animal's appearance.

If the cavesson is insufficient, the rigging described below should be used.

The cuff—A strap of double thickness of leather, 18 inches long and 1½ inches wide, is sewed to a D ring 3 inches long and made of ⅜-inch round iron. A piece of thin leather 9 inches long and 3 inches wide is sewed on the inside of the strap next to the D ring; a buckle and keeper are sewed on the outside of the strap as shown.

The surcingle.—Two 3-inch rings are sewed on the outside of the issue surcingle and are so placed that when the surcingle is adjusted the rings will hang down in the position of the quarterstrap rings of a saddle.

A rope ¾ inch in diameter and about 20 feet long; an eye splice should be made at one end.

This rigging can be easily made in any organization. For use in the field, the rope is replaced by a lariat. The cuff and surcingle together weigh only 2 pounds 5 ounces, and can readily be packed in a saddle bag.

(To be continued)

KEEP STORAGE BATTERIES FULLY CHARGED IN WINTER

A fully charged storage battery with electrolyte of proper density will not freeze at temperatures down to 60 degrees below zero, hence if the battery is fully charged there is no danger of storage batteries freezing.

A battery that has been completely discharged will freeze at a temperature of from 15 to 20 degrees above zero and as this is about the normal temperature at this time of the year in a large part of the country the danger of frozen batteries and cracked jars is considerable.

Unlike automobile radiators, there is no anti freeze compound that can be added to batteries to prevent freezing.

HINTS

Unless care is taken to have the surface absolutely clean, considerable difficulty is encountered in attempting to paint over polished brass. To insure a satisfactory job, the brass should first be scoured with a mixture of salt and vinegar to remove all grease, after which the surface should be washed with hot soapsuds and wiped dry with a clean rag. Thereafter the paint may be applied without risk of its running while wet or chipping off after it has dried.

An excellent way to locate suspected leaks in the carburetor float is to immerse the part in hot water. In this way any gasoline in the interior will be vaporized and will force its way out of the hole, which may be located by watching for the bubbles to rise. The float should of course be removed from the water the instant the bubbles cease arising.

There was serious talk of granting franchises to run automobiles in Syracuse, N. Y., at the time of their introduction.

ED. RUDOLPH

DISTRIBUTOR

FORD MOTOR CARS

FIRESTONE TIRES AND RIMS

MOTOR CAR SUPPLIES



AS ONE OF THE FORD DISTRIBUTORS MR. RUDOLPH IS "THERE". HOW DO WE KNOW? THAT'S EASY, HE'S A READER OF THIS PAPER.

PAYMENT OF CHECKS BEARING FORGED ENDORSEMENTS

(Copyright, 1911, by Ralph H. Butz)

The payment of negotiable papers bearing forged endorsements is not such a rare occurrence as many business men seem to believe. Every once in a while some clever swindler gets possession of other people's checks, or other forms of negotiable papers, after which he forges the endorsements and gets the money for them.

When a bank has paid a check bearing a forged endorsement it usually attempts to evade the liability occasioned by the loss to the owner or depositor through payment to the swindler. It will, therefore, be of particular interest to every bank depositor to know that the courts usually hold banks liable for payment of checks bearing forged endorsements.

A bank which pays a depositor's check bearing a forged endorsement cannot charge the amount to the depositor's account, unless the depositor is guilty of negligence which caused the bank to pay the check. In such a case the bank is not excused from liability because the depositor fails to give it prompt notice upon discovering the fraud, where it appears that the forger has disappeared before the depositor discovered the forgery.

A bank which collects a check on a forged endorsement is ordinarily liable for the amount to the true owner of the check. However, a collecting bank may be released from liability of this kind, although the depositor has no intention of bringing about such release. Thus where a check was stolen from the depositor before it had been delivered to the payee, and the depositor did not notify the bank but allowed it to charge the check bearing a forged endorsement, the depositor could not hold the bank liable. By failing to notify the bank and allowing payment of the check, he ratified the act of the person who forged the endorsement, and was not permitted to plead that the check was taken from his possession without his consent.

The following case is given as an illustration of a bank's liability when paying checks bearing forged endorsements:

C. O. Fish was engaged in business and was a regular depositor at the National Bank of Commerce. His agent, Graham, transacted a portion of the business, and quite frequently Fish sent Graham

checks to be delivered to other persons to whom the checks were made payable. Graham, however, did not make proper delivery of all the checks that were thus forwarded to him, but retained several of them on which he forged the endorsement of the payees and then wrote his own endorsement beneath and later presented these checks to the First National Bank and received currency in exchange for them. The National Bank of Commerce paid these checks and charged them to the account of Fish, and returned them to him as paid checks.

Later on it was discovered that Graham had forged the names of the payees to these checks, but before this discovery he had absconded, leaving no assets. Fish then sued the National Bank of Commerce and the First National Bank, and the jury returned a verdict in favor of Fish against the National Bank of Commerce for \$3,700, the amount of the checks. The National Bank of Commerce appealed from this verdict and judgment, but the higher court upheld the judgment of the trial court, saying:

"The relation between bank and depositor is that of debtor and creditor. When a depositor issued a check upon his bank, payable to payee or order, it is the duty of the bank to pay currency for the amount of the check to the person named in the check or upon his genuine endorsement. Failure to do so is at the peril of the bank. The reason for this rule is quite apparent. The depositor cannot know the signatures of the persons to whom he issues checks, and is neither called upon nor expected to identify the payee or his signature. The bank, upon the other hand, may decline to pay until proof of identification is furnished. It is not practicable for banks at all times to require proof of the genuineness of payee's endorsement, so a custom has arisen among banks that requires the bank which cashes the check in the first instance to endorse it in such a manner that all prior endorsements are guaranteed by it, and relying upon this guarantee the bank of deposit pays without further enquiry, and if a check has been paid upon a forged endorsement the bank of deposit has no right to charge the amount of the check to its depositor, but must look for its remedy to the guarantee of the paying bank or other intermediate endorsers. Unless, of course, the

depositor has been guilty of negligence which induced the bank to pay, or having learned of the forgery in time that notice to the bank would have saved it the loss, and failed to do so, or was guilty of negligence in some form."

GRINDING HIGH SPEED AND SELF HARDENING STEELS

In tool work, the nearer the tool is forged to the proper shape the less grinding will be required. If users of the type of tool grinding machines which are provided with a cupped wheel have trouble with the cracking or checking of high speed steel tools, it is invariably caused by the operator undertaking to keep the tool cool by using water while taking in the heavy roughing cuts. This can be obviated as follows:

Have tools rough forged to approximate shape.

Grind tools slowly at first, until tool becomes warmed through, then grinding can be forced without injury to the tool, but do not use water on a roughing cut, as the water will not overcome the heat and will check the steel. Getting it hot will not hurt it if kept dry.

After rough grinding temper the tool. Then return tool to grinder for dressing up and use plenty of water, as with these light cuts, water will keep it amply cool. As tool becomes dull, dress up, using water.

If the above be followed, no trouble should be encountered from the checking or cracking of either high speed or self hardening steel.

IF YOU RUN OUT OF GASOLINE

Four miles to the nearest garage and no "gas." My Prest-O-Lite tank was almost full. I removed same from the running board, took the hoses from the two head lights and connected them together and put one end on the Prest-O-Lite tank, and the other I put in the air valve on the carburetor. Opening the valve on the Prest-O-Lite tank would make the gas flow into the carburetor. I cranked the engine and it ran very nicely. My friend was sitting on the front fender holding the tank and regulating the flow of gas. By opening or closing the valve on the tank we got a good mixture and the car ran fine, going about 12 m. p.h. We got into town without one single stop.—Wm. Jacobson,

Queries-Answers-Notes



THIS department is the meeting place where you are free to ask for information, answer questions, discuss shop matters and business conditions and any other notes you feel would be of interest to a fellow mechanic. Make use of this Department as often as desired.

A Question of Tempering—In our blacksmith shop we are making at spare times about 50 rag iron springs for corn shellers. These we are making from old buggy springs. Now, as we have to draw the temper from them we would like to re-temper them. They must be hard and still flexible, especially during frosty weather.

William Schwinck, Nebraska.

Sensible Talk—A few days ago I asked a young man if he would come and learn the blacksmith trade. First off he wanted to know how long will it take me to learn, what does it pay while learning what does it pay when I get it learned?

Well, I told him the best I could and he laughed and said: "what do I want to work three years for just to learn to work hard and get \$3.50 a day when I'm getting that now for eight hours' common labor?"

Now, if all blacksmiths would look into their finances just like the young man of whom I have been speaking, they would quit the business. There are not six out of ten blacksmiths making \$5 in a ten hour day, I mean clear of all expenses. Now, the question is, will it pay to go into the auto business and whether in a short time it will be like the blacksmith business. Now, I expect some reader will laugh at this suggestion but I can mention three different garages that have sold out from two to three times in the last five years—what is wrong?

I was about ready four years ago to invest \$6,000 in a garage when my wife called my attention to this situation and I changed my mind and gave it up. I am of the opinion that if the blacksmiths would get their prices up like the garages have that there would be more money in blacksmithing for the smith is the best mechanic and here is a little incident that will illustrate the point I have just mentioned.

Last week a farmer came to my shop with his wagon and said that he wanted three tires and some spokes and made the remark that "I have driven my old auto for the last seven years and have made all the repairs on it. If it had been on the auto I could have more than likely fixed it myself for I can get most any part for it at any old store, but that old wagon I have to bring to the shop."

The editor of our trade paper will say it is up to the blacksmiths to better his own condition, that is true, but when our paper is read work. Blacksmiths as a rule are poor financiers and if our editors would get after that part there would be more blacksmiths able to buy a trade paper.

I can say "Thank God that Ohio will soon be dry" that will improve many a

blacksmith shop for a great many blacksmiths are heavy drinkers. I would like to see more blacksmiths writing to the paper, that is one way of helping one another.

A Reader, Ohio.

(We hardly feel that the automobile repair business will come to the present pass of the blacksmith business for



H. B. Farthing, of Canada, needed a tractor and having an ancient Oldsmobile engine and a miscellaneous assortment of junk around his shop, went to work and built one. Despite its looks, the tractor shown has given excellent service. Our milk man would doubtless conceal a guilty blush on seeing the radiator of Mr. Farthing's tractor.

reasons that will be manifest. There is always going to be a demand for auto repair work and the man who can combine this with his ability as a smith in an intelligent manner is bound to cash in.

We are not willing to believe that the blacksmith is any less of a financier or business man than the "run of mine" so to speak, in any other "one man" business. It is true however, that a great many of the men engaged at the work are working under the handicap of insufficient education which is more to their credit than any reflection. The old time blacksmith lacking in educational advantages and compelled to labor early and late to support himself and his family is seeing to it that his sons are not similarly handicapped and instead of taking them into the shop and putting them to work

when they can handle a hammer he is giving him the benefit of the best education he can afford.

We certainly do not believe that the blacksmith as a class is to be pitied, they are rather to be praised for their labors. We do not believe that the day of the blacksmith is past but the time when a man could make a living to compare with present day standards by shoeing horses, making wagon tires, etc. most certainly has passed. Ed.)

Two Good Helpers—Please send me a copy of Dykes Automobile Encyclopedia. I have been getting so much information out of your journal that I though it advisable to get this book also. Must say that your journal is the best I have ever seen and there is only one thing wrong with it that I can see—it ought to be a weekly or a daily, rather than a monthly journal. I can hardly wait after one issue arrives till the time comes for the next one.

I must make mention about prices also. I am getting fairly good prices for my work although some are getting a little better, but on the average, I am on the top with prices by far in our locality. I have found it mighty poor policy to let the other man set the prices for if it was left to him a person never would get what he should have. I, in my opinion, have a man figured that is afraid to ask the price the work is worth, as a scab or a poor mechanic, or both and that his work will not back up his prices.

Am starting in the automobile and tractor repair business and if later on I run across any new kinks I will let you hear of them.

Steinke, Ohio.

(Letters such as this are always welcome. Who will be the next man to tell us about conditions and prices in his neighborhood? If we didn't hear from you last year, start the new year right and write—Ed.)

From New South Wales—"I desire to congratulate you on the standard your journal has attained as an assistance to the craft."

Stan Cusack.

(Mr. Cusack is a member of the firm of Cusack and Palmer, coachbuilders, Wheelwrights and general blacksmiths. His firm is also one of the Australian agencies for Chevrolet automobiles which are quite popular there—Ed.)

Bosch Magneto on Ford—Can you tell me how I can put a DU4 Model T Bosch magneto on a Ford car.

John Swenson, Mass.

In Reply—It is possible to install the magneto mentioned on a Ford car although additional fittings will be necessary to attach the magneto. Ordinarily the magneto is positively driven by gears. This set of fittings including gears and gear housing magneto bracket, etc. are obtainable from the magneto manufacturers. Also it must be borne in mind that the magneto must rotate—clockwise or anti clockwise—as the case may be with the engine. The direction of rotation of the magneto is indicated by an arrow on the cover of the oil well at the front of the magneto.

J. S. H., New York.

Carbon Removers—What kind of carbon is there on the market that you can recommend?

K. H. L., Illinois.

Carbon removers of the kind introduced into the cylinders are not particularly recommended. The best way to get rid of

carbon is to scrape it out or have it burned out with oxygen. If the carbon deposit is heavy, the so called carbon removers will have small effect.

Wants Out of the Factory—Like many others I hope to escape the drudgery of factory life and make a bid for a few acres and a change of occupation. This might be much enhanced by knowledge supplied by your publication on autos, tractors, etc.

I am no idle dreamer of dreams but thoroughly practical and progressive. I have followed blacksmithing factory work for 27 years and have been as successful as most but it doesn't bring very much grist to the mill but I am still living in hopes. I am a fairly good woodworker and handy at general metal work but am handicapped with too much of the "ca canny" (Scotch for cautious) but it has steered me fairly clear of pitfalls.

Sam Niven, Canada.

"Lit at Last"—I have just lit at last. I have been on the go for nearly a year and have bought a shop here in the best farming country in Colorado. Prices here are fairly good. I quit at Harlan over a year ago, in place of putting prices up they put them down so I quit. I have been waiting to get permanently located before letting you hear from me but even though I am short on change, I want to get the paper regularly. Fixing up my new shop takes a lot of money and a good bit of it only goes a long way but I still have a dollar for the paper.

W. L. Craig, Colorado.

The Maple Leaf Forever—I have been a reader of your paper for some time and find some valuable information in both the auto and horseshoeing departments. My father has a general blacksmithing shop with a 4 h.p. Fairbanks-Morse gasoline engine for power. We have also a band saw, buzz planer, boring machine, lathe and drill press, punch and shear and grinder; altogether a rather well equipped shop I should say.

We manufacture buck wagons, dump carts and during winter, logging sleds and single horse sleds. We also do horseshoeing and find your paper quite a help in all our lines of work. I have a McLaughlin-Buick car and your auto department comes in fine and I follow the different hints on auto work with much interest.

J. J. Murphy, Canada.

Concrete Engine Base—The accompanying illustration will clearly indicate the forms required and as no two engines are the same as regards the location of bolt holes, no dimensions are given.

Naturally the base will have to conform to the size of the engine and the mold made accordingly. It is possible to cast the base in one solid block and then locate and drill the holes and use expansion bolts but the method of casting the bolts into the foundation will be found simpler and much more satisfactory.

If possible take the measurements for the holes from the bottom of the base. Take two sticks that extend from side to side of the mold as shown and carefully measure the distance between the holes lengthwise and diagonally as well as from the sides of the mold so that the engine will be located in the center of the base. When the locations for the bolts have been accurately found, drill holes in the cross pieces the same size as the bolts

used. Put the bolts through these holes, heads down and screw on the nuts to hold them in this position, as shown in the illustration and allow sufficient room on the threaded end of the bolts to permit the bolts to pass through the engine base and accommodate the nut fully. Allowance should also be made for a flat washer between the nut and the engine base.

The concrete mixture for the base should be composed of plenty of cement, some

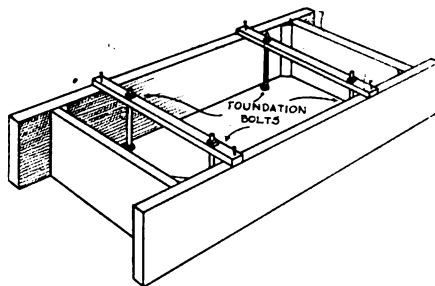

SHOWING HOW THE BOLTS ARE SPACED AND HELD IN PLACE BEFORE THE CONCRETE IS POURED.

sand, gravel or crushed rock and water. If possible, use all sand, as this will make a better appearing and smoother job, although it will not be quite as strong as one made with gravel or crushed rock. The cement should be rather thick when it is poured into the mold. As soon as the concrete has set sufficiently, remove the nuts from the bolts and take off the cross pieces and using the top of the mold for a guide, smooth down the top of the base with a board until it is perfectly flat. A trowel or knife may be used to finish up around the bolts, but of course they must not be moved from their position.

Three or four days should be allowed for the concrete to thoroughly set and the

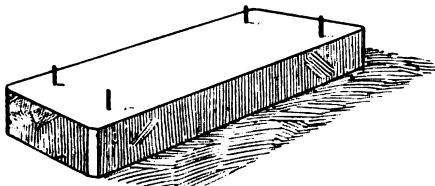

COMPLETE AND READY FOR THE ENGINE.

mold should be left in place for about a week after the engine has been mounted to prevent the corners from chipping off.

S. S., New York.

Electric Welding, Etc.—Received a letter from the . . . Electric Co., about my dynamo. They say that I cannot weld with it because a special dynamo is required for welding. My dynamo is 125 volt, 24 ampere capacity, while it takes a generator with a 125 volt-150 ampere capacity for electric welding. They claim electric welding only requires half the time and one sixth the cost of other welding methods. The price of this outfit is quoted at \$1021—a pretty heavy price for a blacksmith, besides the power required for its operation, although gas for the oxy-acetylene welder comes pretty high nowadays. It costs me \$17.30 to load up with a 200 foot tank of oxygen and two 100 foot tanks of acetylene and can only

get one tank at a time, especially of oxygen. And I have to figure in the cost of express in addition as well as the cost of good tools to make headway, to make the process pay as it is all light welding that I have to do; parts of farm machinery, etc.

I have a 3 h.p. kerosene engine and run my dynamo for lighting, power blower, grinder, drill, boring machine, bandsaw and planer from it. I was looking for a small dynamo this fall so I got a chance on this machine that I have mentioned. I sized it up and as it looked about the same size a party was using for welding, I bought it, thinking that I might rig up some sort of an electrical welder with it, knowing that no more power would be required to run 10 or 12 lights than a smaller one, in fact it runs steadier than a smaller generator as the windings are heavier and it has a flywheel.

I would advise any country blacksmith to have a dynamo for lighting as he can have light where he wants it and light that is safe and always ready, especially around automobiles. I have no storage battery as I consider it an expensive rig and more or less of a nuisance.

I have two pulleys on my engine so when the generator is not being used power is saved but as I generally work at the fire I run the blower too. It costs me six cents an hour for gas to run the blower and dynamo now but I think that the engine is using too much. I had a 4.5 h.p. Olds gasoline engine that would run my blower for 12 hours steady on one gallon of gasoline. I sold it on account of the water tank which was too much bother in cold weather.

Say, Editor, you're a pretty well posted man. Can you find a way to cut out the insurance man some by getting all these iron pounders together and when one happens to burn out, all chip in and put him on his feet again. You know these iron pounders. All they seem to know how to do is to pound and pound. He don't seem to care anything about books or pencils and sometimes, not even money, so long as he has a piece of iron he can hammer at. So you see, if he happens to burn out and the insurance man comes around and asks to see his books, what's he going to do—pound the man, that's all.

I wish you would study it out and get it going if it's possible. Now that I've swam half way across the pool, I'll turn around and go back. Next time I come I may swim across.

W. R. Michigan.

(The insurance idea is a good one and this idea is back of most Mutual insurance companies. The farmers of the country operate a great many such insurance companies. Such a proposition could not be made to work, we feel, unless all would be expected to pay dues regularly with appropriate penalties for failure. Human nature has not yet been educated to the point where an insurance plan such as mentioned above would work. Maybe when the Socialists get through with us things will be different. However, a Blacksmith's Mutual Insurance Company, regularly organized and officered and collecting, regular and fixed premiums the same as any other insurance organization would be entirely possible and practical and would have a decided tendency to reduce insurance costs just as it has done in the case of the farmers. Editor.)

AMERICAN BLACKSMITH AUTO & TRACTOR SHOP

VOLUME 18

FEBRUARY, 1919

NUMBER 5

BUFFALO, N. Y., U. S. A.

Established 1901. Published Monthly at the Sidway Building, Buffalo, N. Y., by the

AMERICAN BLACKSMITH COMPANY

Incorporated under New York State Laws.

WILLIAM F. WENDT, *President.*

WALTER O. BERNHARDT, *Editor.*

SUBSCRIPTION PRICE:

For \$1.00 per year, payable in advance, The American Blacksmith, Auto & Tractor Shop will be sent, postage prepaid to any postoffice in the United States. To Canada, \$1.25; to other countries, 6 shillings. Reduced rates to clubs of five or more on application.

Remittances may be made by money order, express order or checks payable to the American Blacksmith Company. We will also accept uncancelled postage stamps or currency, but for safety these should be sent by registered mail.

Subscribers should notify us at once of non-receipt of paper or change of address. In latter case, give both old and new address.

Correspondence on all smithing subjects solicited. Always give name and address, which will be omitted in publishing, if desired. Address all communications to the

"AMERICAN BLACKSMITH COMPANY"
BUFFALO, N. Y.

Copyright W. F. Wendt Publishing Company, 1919.

Cable Address: "Blacksmith, Buffalo"

"THE UNIVERSAL CAR"

Elsewhere in this number our readers will find announcement that has been made by the Ford Motor Co., of its new policy in the sale of Ford parts. Recently the Ford Co. decided to allow all garages handling general auto repair work the privilege of buying parts through the local Ford dealers at a discount of 25% from list. There are no conditions surrounding this proposition, the idea being to stimulate and encourage all repair shops to take an interest in the maintenance of Ford cars. The company contemplates, by means of traveling roadmen, to educate the garagemen in the proper methods of overhauling and adjusting Ford cars, and thus make it possible for owners of Ford cars to secure satisfactory service from other than the established Ford dealer.

An enormous increase in the production of Ford cars will be made during the coming season, which will overtax the service capacity of quite a percentage of the authorized dealers and the company is therefore taking steps in the direction of increasing service facilities for the production and benefit of its customers.

Ford dealers will be prepared to supply the garages and repair shops in their territory with whatever volume of parts the garage may find necessary to meet its demands, and all garages that indicate a desire to handle genuine Ford parts will be supplied with a window hanger to that effect by addressing the Ford Motor Co., Detroit.

BOLSHEVISM AND ITS LESSON

At this time the world is being treated to an illuminating example of practical and applied socialism in various parts of Europe and the efforts of hare-brained agitators to foist their half baked ideas of an equal distribution of wealth, the elimination of any privately owned property whatsoever and the ownership and

control of all property of whatsoever kind by the state.

The Bolshevik program of eliminating all privately owned property will doubtless be enthusiastically welcomed by farmers and small landowners generally, by the "downtrodden working man" who is "being robbed by the capitalists" but who has nevertheless, been able to accumulate a comfortable bank account and owns his own home. According to the bolshevik and extreme socialist mind such property owners are at least considered as "bourgeois" if not in the hated "capitalist" class. Also according to their peculiar ideas of things it is this class who are expected to welcome bolshevism and its delirious ideas with open arms. You hear your bolshevist agitator glibly spilling his stock line of chatter about the "proletariat" and "bourgeois" (the chances are we have misspelled this word) but get him away from these large and impressive words and he begins to misfire and pop back in the carburetor.

We do not believe such doctrines will be welcomed by anyone in this country with the exception of the elements that usually attach themselves to such organizations—the idler, the ne'er-do-well, the professional agitator, the crank and the shiftless.

The next time you hear some crack-brained soap-boxer shooting off his bazoo about the paradise that socialism or bolshevism is going to make generally when they get to running things and that the "downtrodden workingman" will have a six hour day with two hours for lunch and a lot of other things calculated to gain sympathy and followers, the chances are that he has a privately conducted laundry operated by his wife. There isn't anything wrong with conditions that gentry such as this will ever be instrumental in correcting.

CONTENTS—FEBRUARY, 1919

| | |
|--|---------|
| Electric Arc Welding | 107 |
| Judging Steel | 110 |
| Wrist Pin Fastenings..... | 111 |
| Anti-freeze Mixtures..... | 112 |
| Shoeing an Ox in Chile..... | 112 |
| Rural Motor Express..... | 113 |
| When Bearings Run Hot..... | 114 |
| Garagemen to get Ford Discount on Parts | 115 |
| Copper Coating Solution | 117 |
| Aluminum Alloy | 117 |
| Silvering Process | 117 |
| Preparing Glue | 117 |
| Kinks and Shop Notes..... | 118-119 |
| Adjusting Brakes | 120 |
| Motor Cars in Britain | 123 |
| The Army Horseshoer | 125 |
| Why a Magneto | 125 |
| The Writing on the Wall..... | 127 |
| Contracts of Minors..... | 128 |

DON'T GIVE MONEY TO AGENTS

The American Blacksmith, Auto & Tractor Shop DOES NOT employ subscription agents. Any person representing himself as such is an impostor and should be so dealt with. Notify us immediately if anyone claiming to represent this journal calls upon you.

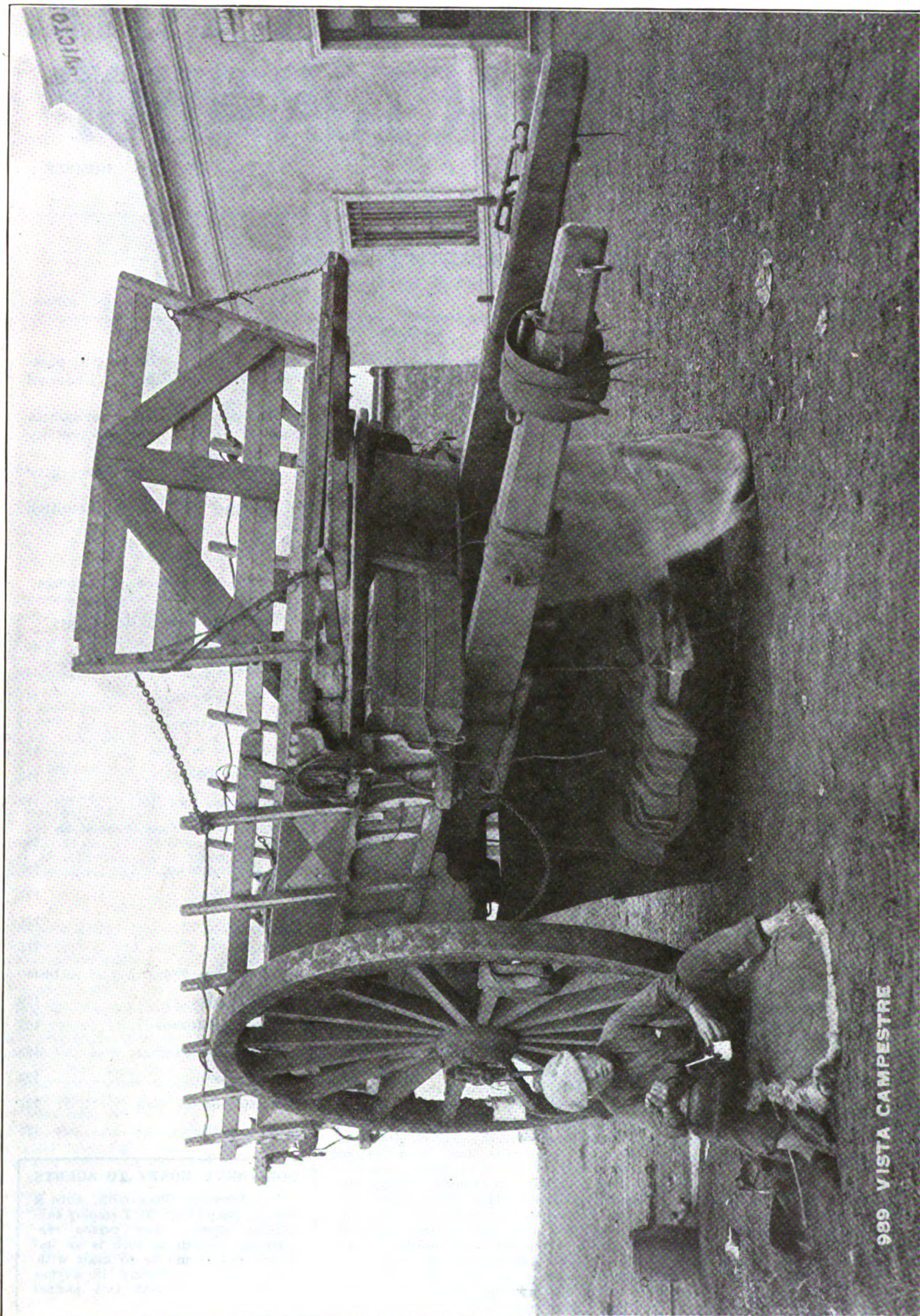

989 VISTA CAMPESTRE

An Argentinian "Carreta" or cart of ponderous proportions. Such carts haul enormous loads of wheat and other products to transportation centers. One horse is hitched between the shafts and from six to a dozen more are hitched to the wagon with ropes—Good roads and motor trucks are causing such vehicles to gradually disappear in all parts of South America. The driver of this cart, it will be noticed, has his bed suspended from the bottom of his cart and has established himself comfortably for the night.

Electric Arc Welding

A. F. DAVIS

A rule that usually works out satisfactorily is that when you want anything—go to headquarters after it or the man most likely to know—that is the reason we have invited Mr. Davis, who is a welding expert with the Lincoln Electric Co., to write an article on the process and while this article by no means tells everything about electric welding it nevertheless gives a good general idea of the process and the apparatus involved.

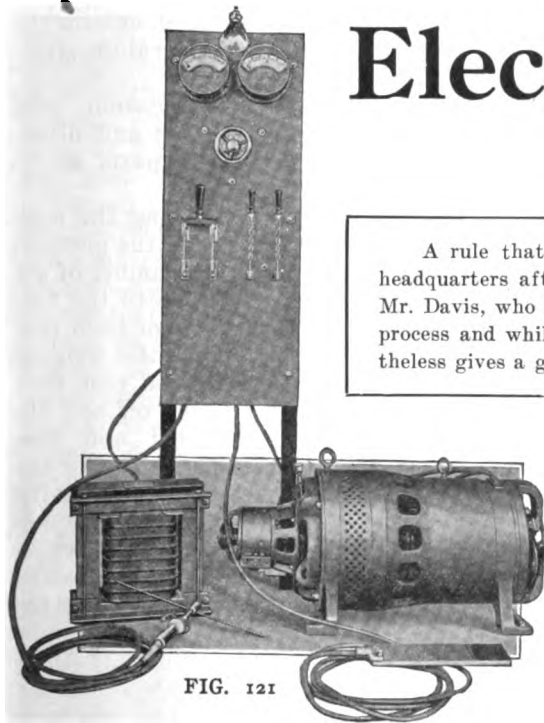

FIG. 121

THE process of welding, in some form or other, has been known almost since the time the use of iron and steel began in the commercial world. The process, of course, has been refined, like all industrial or commercial processes, until it has reached its state as represented by electric arc welding. In order to thoroughly understand the subject of welding, it is necessary to divide it into two general classes of work, one of which we may call forge or pressure welding, and the other, autogenous welding.

The first named is probably the earliest known method of welding and it applies to the process where two metals are heated to the plastic state, then forced together by pressure or hammering to thoroughly unite them and complete the weld. Every blacksmith is familiar with this class of welding. While it requires considerable skill to make a successful forge weld, yet the instruments required are very simple and consist only of a forge, hammer and considerable muscle.

Another form of forge welding is that known as electric butt or spot welding. This weld is made by pressing two metals together, passing a current through the point of contact, this current heating up the metal at the point of contact to a plastic state, pressure then being applied to complete the weld. The only difference between this class of welding and forge welding is

that electricity is used to produce the heat instead of the forge.

Autogenous welding is applied to welds which are made by heating metals to such a temperature that they are fused together on contact without pressure being applied.

The main difference between this class of welding and that previously mentioned is in the temperature of the metal. In the autogenous weld the metals are heated to a state of fluidity and the two metals flow together, while in the other they are only heated to a plastic state and forced together. Autogenous welding, however, is not used merely to unite or join together two pieces of metal, but is used a great deal in the manufacturing processes for adding metal, thus building up worn places or filling defects.

Electric Arc Welding is an autogenous process, the heat of the electric arc being used to bring the metal to be welded to a fluid state. It is used both for joining metal parts and for adding or building metal on such parts. In fact, when two pieces are welded together by this process it is usually done by filling in extra metal between the two pieces, rather than by merely melting the two pieces together.

As is commonly known, an electric arc is formed when current is made to jump from one electric conductor to another through the air. The arc

is produced because the electric current is forced through a medium which offers great resistance to its passage and thus produces heat.

The object from which the current comes is called the positive electrode, the object to which it goes is called the negative electrode.

In electric arc welding, one wire of an electric circuit is attached to or laid upon the steel which is to be welded, the other wire is attached to a piece of carbon or metal which the welder holds and which is called the negative electrode. The current passes or arcs from the piece which is to be welded to the electrode which the operator holds. In doing so it creates such heat on the piece, that the portion of the piece around the arc actually melts and turns into vapor and the arc is continually passing through this vapor. (See Fig. 1).

Electric arc welding may be divided into two general classes,

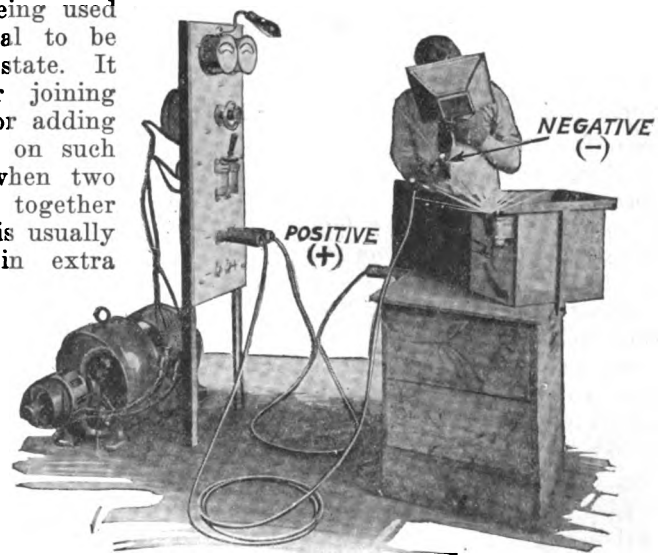

FIG. 1. In arc welding, one wire (the positive) from the welding apparatus is attached or laid upon the steel which is to be welded, the other wire (the negative) is attached to the electrode of carbon or metal which the operator holds.

one called the Carbon Electrode or Bernardos Process, and the other the Metal Electrode or Slaviano Process. Both types were introduced some twenty-five or thirty years ago, but it was only in recent years that either process has become widely known.

In the case of the carbon process, the electrode consists of a carbon

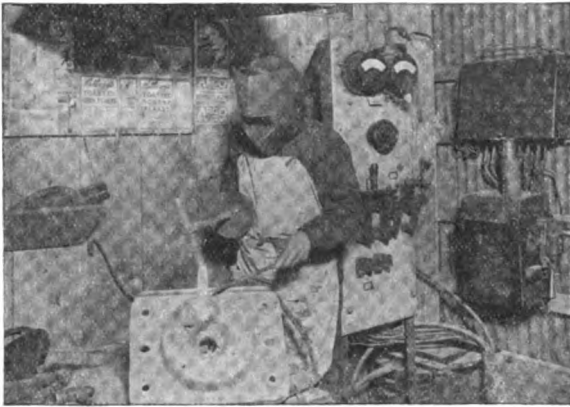

FIG. 10. Carbon Electrode Welding. The operator holds the carbon electrode with the right hand and feeds the filling metal in to the weld from a rod held in his left hand

pencil from $\frac{1}{4}$ to $\frac{1}{2}$ " in diameter and from 6 to 12" in length and pointed to bring the arc into as small a space as possible. The carbon arc is simply used to supply the heat and the operator feeds in the filling metal from a melt bar held in his left hand. (See Fig. 10).

In the metal electrode process the electrode consists of a metal wire of comparatively small diameter and the arc is formed between this wire and the work which is to be welded. This wire gradually melts away, furnishing the metal which is filled in the weld. (See Fig. 11).

The metal electrode process is used for the large majority of all welding work. The heat is only spread over a very small area, enabling the operator to deposit the metal very accurately on the edges of sheets, plates, etc., and enables a smoother job to be made than by the carbon process. It also prevents any carbonization of the weld and so eliminates the hardness which is sometimes found in carbon welds, from allowing carbon to get into the weld.

In practice the application of the carbon and metal electrode processes overlap, but in a general way the carbon process is only used when desiring to do fast welding or to heat over a large area. Such

work is found in the filling in of large holes in castings, filling in cracks, blow holes, sand spots, etc., in large steel castings. This process is used to a very large extent in steel foundries, where a current of from 300 to 600 or even 800 amperes is used.

Electric arc welding is more successful on steel and iron and the various alloys of these metals. Cast iron can be successfully welded, but requires considerable more care and experience than the welding of steel. Cast iron should be carefully preheated before the weld is made and allowed to cool very slowly after the weld is made, the weld being made when the material is at a red heat. The necessity for this care in the welding of cast iron is due to the fact that its nature is such that it is very brittle and unless the material to be welded is carefully preheated, expansion and contraction strains are set up, which very often crack the work in place from where the welding is being done.

Other metals have been welded the chief of which has been copper. An illustration of this class of welding, which is familiar to all, is the welding of copper rail bonds on street railway tracks. This operation is very successful and leaves a very solid and successful weld. Other metals have been welded but in very few cases are they a commercial success.

The process of arc welding may, in a general way be divided into three classes or operations:

First: The preparation of the material to be welded. This includes the laying out of the job and deciding as to the best way for the job to be done so as to avoid any possibility of contraction and expansion strains, etc.; also deciding as to the best size of electrode to use, the kind of electrode, etc.

Second: Striking or starting the arc and adjusting the current to the proper value for the electrode to be used and the job to be done. In starting operation it is best to strike the arc on a piece of scrap plate or material and adjust the

machine to give the proper current. The arc may then be struck on the work and welding operation started.

Third: The manipulation and maintenance of the arc and filling in the metal on the parts to be welded.

The work of preparing the material to be welded is of the greatest importance. A great number of unsuccessful welds is due to the fact that the material has not been properly prepared before the welding is started. Scales, grease, rust, dirt, etc., should be cleaned off and the work entirely cleaned and free from impurities. This cleaning can be done by means of a metallic brush, a rough file or chipping hammer should be used. Where a sand blast is available, this provides a very good method of cleaning the parts to be welded. Care also must be taken to see that the parts to be welded are in the proper shape. For example, where two pieces of boiler plate are to be welded, the edges should first be beveled so that the pieces may be welded clear through from one side of the plate to the other. Figure 126 or 132 show some typical welds and illustrate how they should be prepared for welding. The arrows merely show stresses which will be brought to bear on the joint after it is com-

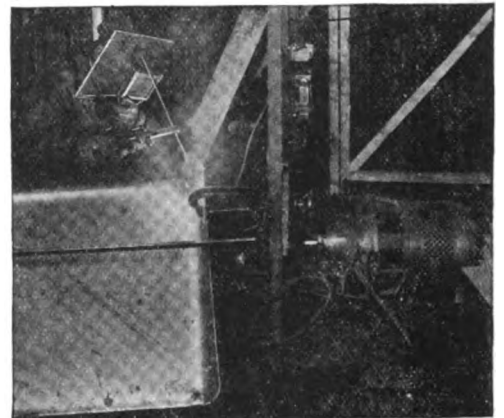

FIG. 11. Metal Electrode Welding. The electrode in this case, is a metal wire of small diameter and this wire gradually melts itself away, furnishing metal for the weld

pleted. Figure 35 also shows a good illustration of preparing for a weld. Figure 35B also shows the completed weld.

After the work has been properly prepared it should be connected to the positive side of the D. C. power supply. The electrode is connected to the negative side. Inasmuch as the voltage across the arc

on metal electrode work varies between 14 and 25 and on carbon work between 35 and 45, and inasmuch as the usual power supply available is either 110 or 220 volt D. C., or 2 or 3 phase A. C., it is easily seen that some method must be devised to transform the alternating current to direct and change it to a voltage suitable for the arc. Furthermore, the voltage of the arc is dependent upon the length of the arc, and as it is impossible for the operator, at all times, to maintain a constant length of arc under welding conditions, it is seen that the voltage of the arc is constantly changing. Some method must also be employed to give this changing voltage at the proper value.

The first method designed was to

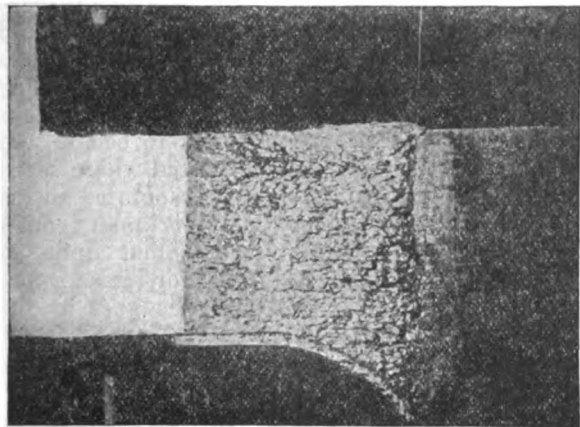

FIG. 35B. AFTER. The Completed Weld. A piece of boiler plate is placed around the bottom of the gas as shown in the illustration, in order to hold the new metal in place

use 110 or 220 volt direct current supply, and introduce a bank of resistance in series with the arc of sufficient capacity to cut the voltage down to the voltage required at the arc. This resistance not only accomplishes the purpose of cutting the voltage down but also provides a means for obtaining the varying voltage of the arc. While this process was fairly successful, it is seen that it was extremely uneconomical, as from five to ten times as much power was lost in resistance as was actually consumed in welding. If the power supply was alternating current, a motor generator set was provided to transform the power supply into the direct current required.

The next step in the process of refinement was to furnish a motor generator set, which would transform the 110 or 220 volt direct current, or, if the power supply was alternating current, to change the alternating current to direct cur-

rent at a voltage of approximately 70. A grid bank or resistance was then introduced in series with the arc to stabilize the arc and give the varying voltage required. With this equipment was furnished a switchboard, meters and various forms of relays for controlling the current and preventing an inrush of current when the arc was first struck. While this equipment was also fairly successful, even this method can be seen

to be unsuccessful, as in metal electrode work a very large amount of power is lost equal to the current times the difference between 20 volts and 70 volts.

Some half a dozen years ago several engineers began to figure as to how it would be possible to eliminate this waste of power. It was also found that welding was done in the great majority of cases by people, who, while good welders, knew nothing about electrical apparatus. The designers, therefore, had two ideas or problems in mind.

First, to design a machine which would give the varying voltage demanded by the arc, and second, to produce a machine of extreme simplicity, without the use of automatic relays, switches, etc., which would get out of order, and which would permit easy maintenance of the arc.

As a result of these studies and experiments, what is known as the variable voltage, single operator machine was produced. (See Fig. 120-121.) This machine, as is to be seen, is of extreme simplicity, yet permits the arc to be easily maintained and rapid work to be done. Since this original machine was produced a large number of variations have been attempted by various companies with greater or less satisfactory results. As a usual rule, additional equipment, in the way of relays, etc., have been provided, which does not, in all cases, per-

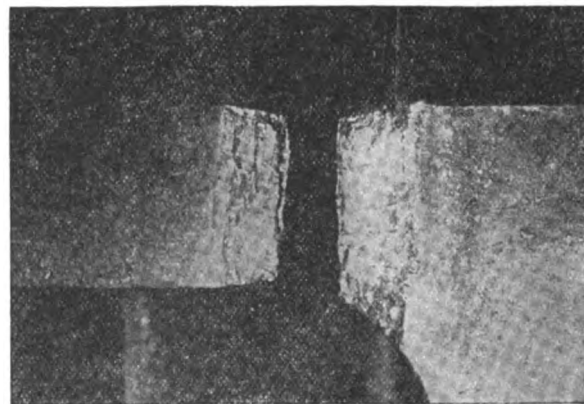

FIG. 35. BEFORE. Broken Engine Frame with break cut out, prepared for welding.

mit continuous, reliable and successful operation.

While a full description of this machine and its theory of operation is beyond the scope of this article, it may be said that it fulfills all the requirements of a successful welder, namely, low power consumption, economy of operation, simplicity, reliability, easy maintenance of arc, easy current adjustment, etc. Various modifications of this machine are possible so that it can be arranged for different power supplies, or arranged for belt drive, (See Fig. 122), or gasoline engine drive, (See Fig. 123).

There has lately been placed on the market what is known as the alternating current welder, which is designed to use alternating current for welding rather than direct current. So far, this has not proven

an entire commercial success, and many of its welders have become discouraged with arc welding. If such difficulties have been ex-

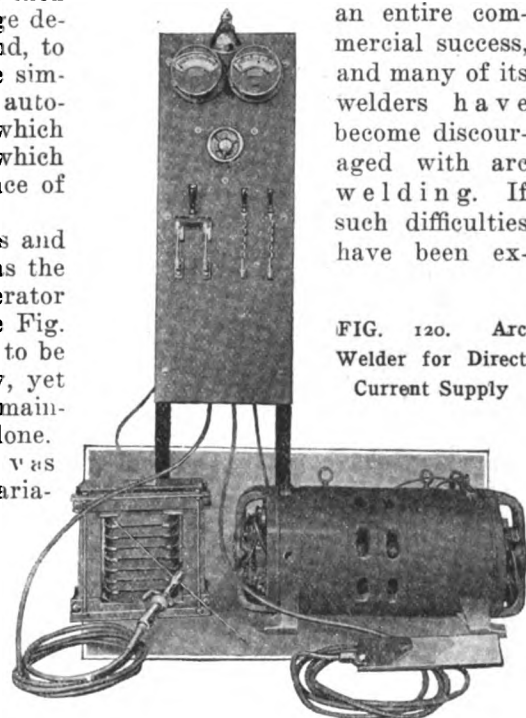

FIG. 120. Arc Welder for Direct Current Supply

perienced, they should not be laid up against the arc welding process. If proper equipment is provided, successful welding is within the reach of all.

After the work has been connected up, as previously mentioned, to the positive side of the direct current circuit, and the electrode to the negative side, welding operations may be started. The arc is

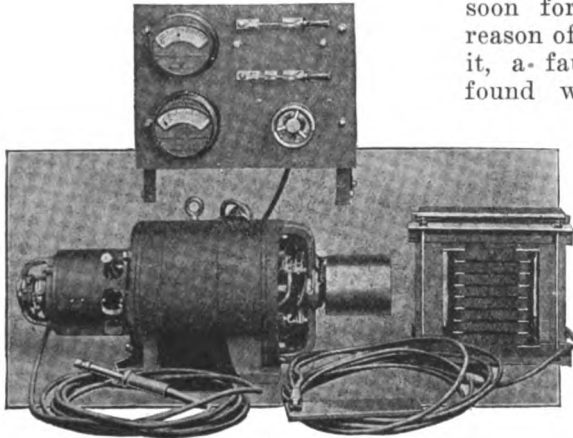

FIG. 122. Arc Welder, Belt Driven for use where no electric power is available.

now struck and the current properly adjusted for the work to be done. In striking the arc, some skill and practice is required. The beginner usually draws an arc and starts to weld at whatever point the arc happens to operate properly. In other words, the beginner usually welds wherever it is possible for him to weld, rather than welding in a predetermined place. This can be overcome by practice.

(To be concluded)

QUIETING WORN GEARS

The question of the suitability of ground cork as a quieting agent for noisy epicyclic gearing brings to mind several peculiar methods that were employed a few years ago to eliminate the noisy humming of worn-out gears. The mixing of a liberal quantity of sawdust with the lubricant was one method, while another was the filling of the gear-box with shavings of the sort used for packing fragile goods,

the usual lubricant, of course, being allowed to remain.

These materials were supposed to act as a cushion between the teeth of the gears, thus reducing the shock which set up the objectionable humming and vibration. Cork, being a much more elastic material than sawdust, ought to be more efficient for the purpose. Ground rubber might be even better but for the fact that it would soon form a semi-fluid mass by reason of the action of the oil upon it, a fault which would not be found with cork, although any

medium would ultimately lose its properties by being finely ground. There is some evidence that the plan of introducing sawdust, etc., into the gear-box is at least temporarily effective. It is not unknown to some of those who prepare second-hand cars for sale; and even public service vehicles have managed to pass a silence test by

this means.

It may be asked what, if any, objections there are to the plan. There does not seem to be an obvious reason why it should cause

mechanical injury to the gearing, providing that no solid matter is introduced, such as pieces of metal, which would jam the gear, but there is at least one serious objection of another sort, namely, great waste of power by friction due to the churning up of the semi-plastic mass by the gear teeth; the gear-box would, in fact, be acting as a continuous brake. There is also the difficulty of the proper lubrication of the gear shafts and bearings. The former would very likely make itself felt by causing stiffness in the operation of changing the gears.

JUDGING STEEL

In many factories there is a certain amount of carelessness in keeping steel stock, labelled steel is sometimes kept in a damp place where the labels drop off, and where it is the custom to mark the quality of steel bars by painting in different colors it is an easy matter for mistakes to occur. An instance has been cited where seven grades of steel were painted in the same color. A workman consequently is often called upon to judge steel quality for himself, and as a general thing he goes by the general shape of the material, the appearance of its surface, the way in which it fractures, its weight, and "ring" when dropped, its smell, or his intuitive knowledge. At times, these fail him, and he goes by the spark, service and fire and water tests, as he calls them. If the workman possesses a high degree of skill,

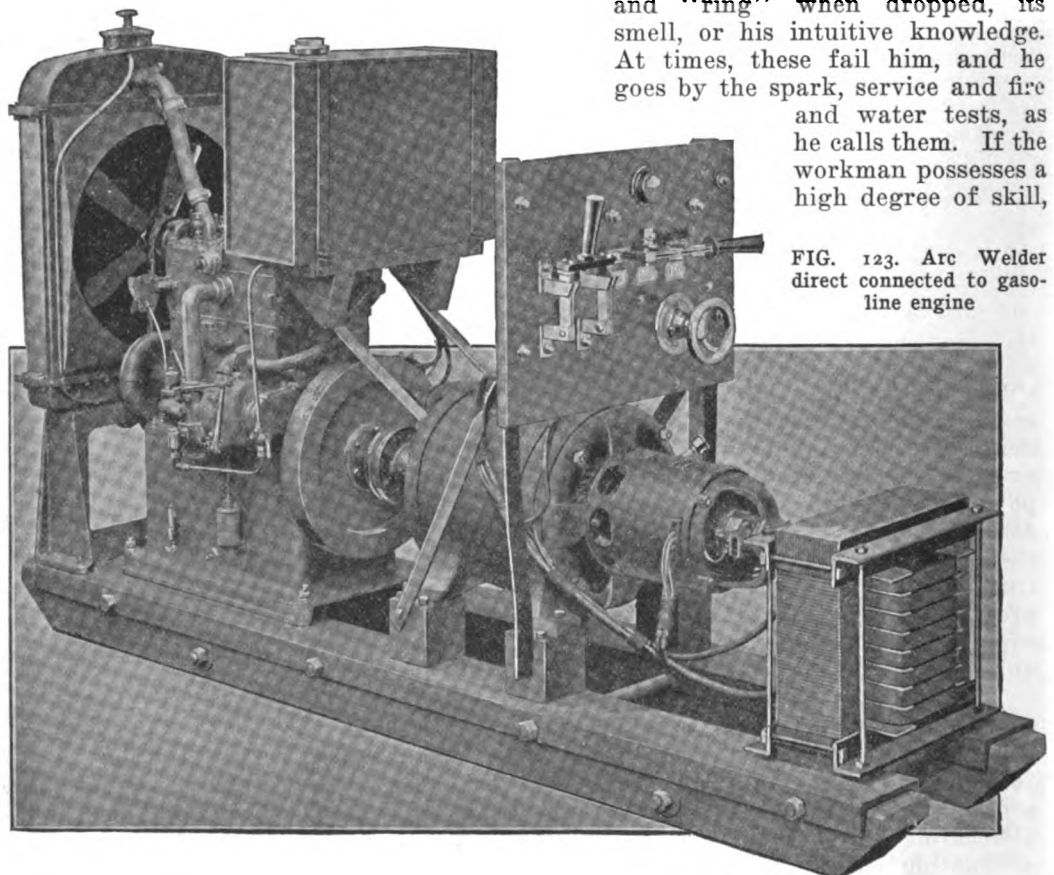

FIG. 123. Arc Welder direct connected to gas-line engine

he can determine quality by any of these to a surprising degree of accuracy, and in regard to tool steel he seldom makes a mistake, going, as he generally does, by the appearance of the surface. It is fairly good evidence to him if the bars have a good, smooth surface, and the corners are sharp and clean. He also goes a good deal by the general shape of the stock; screw stock is always of hexagon section and octagon, section steel generally means suitability for cold chisels and similar tools. As a matter of fact, smooth surfaces and sharp corners indicate work at low temperatures, whilst rough surfaces and round corners are caused by an iron oxide scale when the metal is laid down at high temperature, so that the appearance of the steel stock is not an invariable indication as to either its composition or its quality. According to this authority, however, many workmen are not prone to judge entirely by appearance. They prefer to drop the metal on a hard floor or on a heavy piece of iron. If the ring is of a sharp-clear tone it usually indicates to them that the metal is of good quality. The finer the grain the more homogeneous the structure and the harder the metal the sharper is the note given when falling. These qualities are developed by elements in the metal by working and by heat treating at a moderately low temperature. On the other hand wrought iron will emit a dull tone owing to the presence of about 2 per cent. of slag and the usual methods of working such metal at a high temperature. This method is not reliable or dependable because work and heat treatment will affect the tones emitted when the material is struck or dropped.

It is surprising, how many expert workmen will select metal by intuition; and because of their opinion they work the tool into shape regardless of any indication in its cutting properties that the metal may be undesirable. Their mistake is usually discovered when attempting to harden the metal or when putting it into service. It is said that in one of the manufacturing districts it is the custom for a man to nick a bar of stock with a cold chisel break it in two and immediately smell the fracture, claiming that a good quality of steel smells like ammonia. There is not ammonia in steel, and many

of the tests used by the workmen are just as unreliable

The fracture test does not represent the true quality of metal, but rather indicates the last heating operation to which the metal was subjected. A fracture that has a coarse granular appearance may not mean that the steel is of inferior quality but that it was laid down at a high heat, and that the crystals retained the size corresponding to that heat. There are exceptions to this rule however, for many of the elements in alloy steels



prevent or retard crystalization at high temperature. High-grade steel shows an unusually fine grain after being heated to a temperature of 2,250 deg. Fah., on the other hand, carbon tool steel heated to its critical temperature and immediately quenched shows a fine silky structure, and it is doubtful if the average mechanic is able to distinguish these metals when they are placed together for comparison. If a small piece of carbon tool steel is heated to just above its critical temperature, about 1,450 degrees Fahr. known as a dark cherry red and immediately quenched in water, it will be hard enough to resist a sharp file, and when fractured should show a fine silky structure. If a low or inferior grade of carbon steel is treated in this manner the surface may be hard enough to resist a file, but the fracture will not show a fine structure.

Many workmen, as well as the experimental engineer, select available material at hand without any determination as to quality, and then put expensive labor upon the part or tool. When finished, it will be tried out in service and if it fails something else is tried. Such failures are usually found on the scrap heap. The service test, however, has its advantages if the engineer has a knowledge of the material thus tested. This infor-

mation is invaluable as it is the combination of successes and failures that gives the empirical knowledge that completes the perfect understanding of theory. The scrap-heap of failures is the most instructive place about a plant.

The spark method of test is based on the action of oxygen of the air on the combustible element present in iron and in many of the alloying elements contained in the different steels which acts explosively when heated to a temperature necessary for combustion. To produce bright sparks as a result of heating finely-divided particles of metal the heat must be intense, at any-rate sufficiently so as to enable the particles of metal and oxygen of the air to combine chemically to cause complete combustion.

WRIST PIN FASTENINGS

The illustration shows the method adopted in all new Buda engines for preventing the piston pin from working endwise if the set screw becomes loose—a steel spring is sunk into a groove in the piston as shown. The detail shows how the washer is bent up around the head of the set screw on all Buda engines to keep the screw

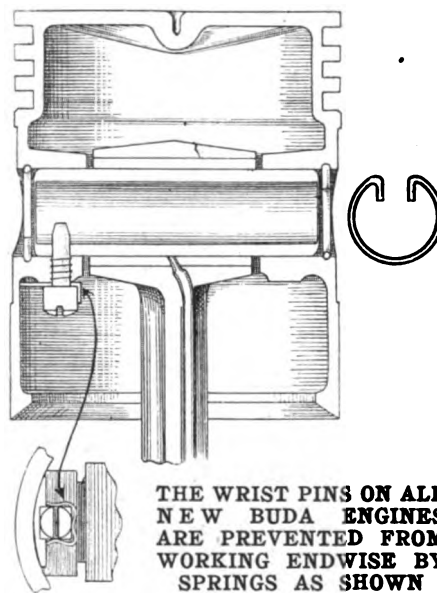

THE WRIST PINS ON ALL NEW BUDA ENGINES ARE PREVENTED FROM WORKING ENDWISE BY SPRINGS AS SHOWN

from turning. In some of the older models of Buda engines an aluminum or bronze plug is used to prevent the pin from working endwise. Some of the older models have a split set screw that is spread out after being screwed into place in the same manner that a cotter pin is spread, to prevent the set screw from working out.

ECONOMY IN LUBRICATION

One half of the troubles experienced with farm machines could be obviated if proper regard were paid to lubrication. This means that not only enough lubricants must be used, but that they must be of the right kind. There can be no economy in using low-grade oil and grease, nor in applying lubricants in less quantity than the machine requires.

Any machine which the farmer may own is entitled to the very best of treatment. Without that its efficiency is reduced, and this reduced efficiency is just the same in effect as needless expense in any

other direction. The more complicated and valuable the items of the farm equipment are, the better the care to which they are entitled. Tractors, gasoline engines, binders, and the like, should receive only the best of everything, including lubrication, both in quantity and in quality. Farmers who own automobiles are beginning to learn the economy of an adequate use of lubricants, but they should not confine the application of this acquired knowledge to their automobiles. Give each machine on the place a chance to do its best. It can't have this unless it is lubricated properly.

They Do Things Differently in Chile

W. K. JONES

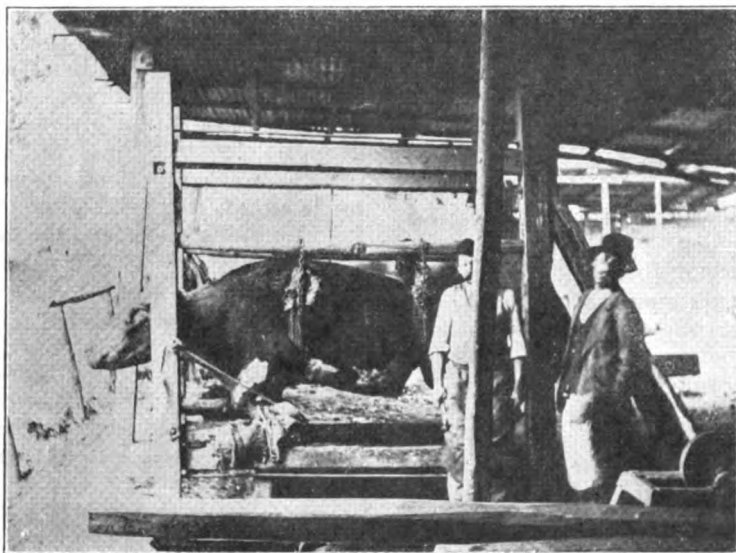

"Shoe the old horse, shoe the old mare,
Let the little colt go trotting bare"

This is not one of the nursery rhymes they teach little Chilean children. While they may be familiar with the horse, most of the children, especially in the country towns, know far more about the ox, the beast of burden in the country. When there is plowing to do, it is the ox which is harnessed to the spindly stick of wood which scratches the ground; and when bags of provisions are to be taken to market, it is a yoke or two of oxen which pull the heavy cart.

Except in the larger cities, oxen are far more frequent in the streets than horses, and blacksmiths have many more oxen to shoe. The

photograph shows a blacksmith in a little country town in the south of Chile. The methods used are most primitive, as is the machinery. The animal is raised from the ground by chains and cloths, a sort of scaffold is built under it to which its foot is attached, and the blacksmith goes to work.

Here is one place where a Chilean characteristic is displayed. "Más o menos" (more or less good) or "it will do" is their standard, and the finished, careful work of the blacksmiths in the United States is rarely seen. However, they are learning. Machinery is being imported, new methods are being tried, and the iron workers are waking to the fact that they have much to learn about efficiency.

AN ARMY HORSESHOER SPEAKS ON AUTOS AND REPAIRMEN

"I used to write a little about my experiences in the horseshoeing line but of late I have not had so much work in that business as I have had in wagon and auto work.

"Now, I will tell you of my experience with automobiles.

"Like every beginner (at least I believe) I had my misgivings about that kind of work and hesitated to take it up. After paying out a good deal of money for work done on my own car and seeing what rotten work by rottener mechanics I was getting, I started out to do my own work and I have certainly been surprised to find it to be an easy and interesting labor. Also, good pay is to be had if a man knows how to do his work in a clean and workmanlike manner.

"Of course I am still working for our Uncle Samuel, this by the way, being my 29th year. I have in the last two years had to do a great deal of auto work and only lately I put in a new differential, a new universal joint and took the engine apart, cleaned it and replaced all packing and gaskets and found that I did a much more satisfactory job than I could have obtained from some of the so-called 'auto experts.'

"From those experts I had work delivered to me on my own car that I had to do over again myself after the car had been driven for a day. Some time ago I had to have some work done on the magneto and was rather afraid to undertake it myself and consequently took the job to a garage. The next day after paying \$9 for the job, I lost the dustpan completely on the road. I said right then and there 'Never again, I'll do my own work hereafter.'

Franz Wenke.

(Editor's Note—Mr. Wenke has been a blacksmith all his life and his evidence is cited to show that the auto repair business is not beyond the grasp of the older men of the craft.)

**ANTI-FREEZE MIXTURES
Calcium Chloride and Water.**

| Pounds of Calcium Chloride per Gallon of Water | Freezing Point of the Solution |
|--|--------------------------------|
| 2 | +18 degrees F. |
| 2 | + 2 degrees F. |
| 4 | -17 degrees F. |
| 5 | -39 degrees F. |

Alcohol, Glycerine and Water

| Alcohol | Glycerine | Water | Freezing Point |
|----------|-----------|-------|----------------|
| Per Cent | | | |
| 7.5 | 7.5 | 85 | +20° F. |
| 10 | 10 | 80 | +15° F. |
| 12 | 12 | 76 | +10° F. |
| 15 | 15 | 70 | - 5° F. |
| 16 | 16 | 68 | -15° F. |

Alcohol and Water

| Denatured Alcohol Water | Freezing Point | Wood Alcohol Water | Freezing Point |
|-------------------------|----------------|--------------------|----------------|
| —Per Cent— | | —Per Cent— | |
| 28 | 72 | 17 | 76 |
| 40 | 60 | 24 | 69 |
| 52 | 48 | 31 | 62 |
| 63 | 37 | 38 | 58 |

The Rural Motor Express

Linking Rural America up with the rest of the world, is proceeding rapidly and the operators of systems are meeting with success. After the war conditions will not interfere with the success of these enterprises.



RURAL Motor Express, that method of transportation over the highways by motor trucks, linking Rural America up with the rest of the world, is spreading over the country rapidly. These individual lines, operating from 15 to 100 miles, are gradually forming into a transportation system, which when linked up will spread over the entire United States.

The Rural Motor Express Committee, of the National Automobile Chamber of Commerce, of 7 East 42nd Street, New York, has for some time been actively engaged in encouraging and aiding the establishment of rural motor express lines, and to that end has sent out to all parts of the country its literature on how to organize a line. This was followed by literature, showing how profitable these lines were, giving the experiences of others who were operating lines, and lists of operators all over the country.

This committee is now receiving reports, showing how profitable a rural motor express line can be made, if operated right.

Here are some of the develop-

ments: — The Highways Motor Transport Company of Cleveland, Ohio, has been operating rural motor express lines out of that city to Sandusky on the west and Ashtabula on the east, taking in all way stations. How successful they have been is shown in the following experiences:—

This company is operating a fleet of ten 6-ton Packard trucks. Last spring a large business was developed in handling hot-house vegetables from Geneva and Ashtabula to Cleveland. When fruits and vegetables began to come in these trucks transported the following: 20,000 crates of berries, 25,000 bushels of tomatoes from the farming districts to the Cleveland markets. These shipments were followed by 20,000 bushels of apples, peaches and beans.

During the grape season this company hauled 84,000 baskets of grapes, part of which went to the wine presses and part to the markets. Seven hundred baskets were carried to the load, which made 120 truck-loads of grapes alone. The average haulage distance of these grapes was 37½ miles and the

charge was approximately \$7 per ton, and the loads hauled approximated seven tons. Empty baskets were hauled on the return trip. The round trip of each of these trucks brought in about \$77.

Troy trailers were used in some cases, of which the company has two 5-tonners. A truck and trailer train during the summer season hauled the following—loaded on the truck were 291 bushels of tomatoes, 9 bushels of cucumbers, 80 baskets of peaches and 13 cans of cottage cheese, not forgetting a number of electric sewing machines for the Red Cross. The trailer carried 230 bushels of tomatoes.

Out of the thousands of baskets of fruits and vegetables hauled by this line not a single basket was damaged or broken open. The farmers had been used to rail haulage, which usually resulted in considerable loss, and they were amazed at the record here made. These farmers are naturally going to see that this kind of service remains, and will patronize it to a greater extent next summer.

The rates charged are here shown:—

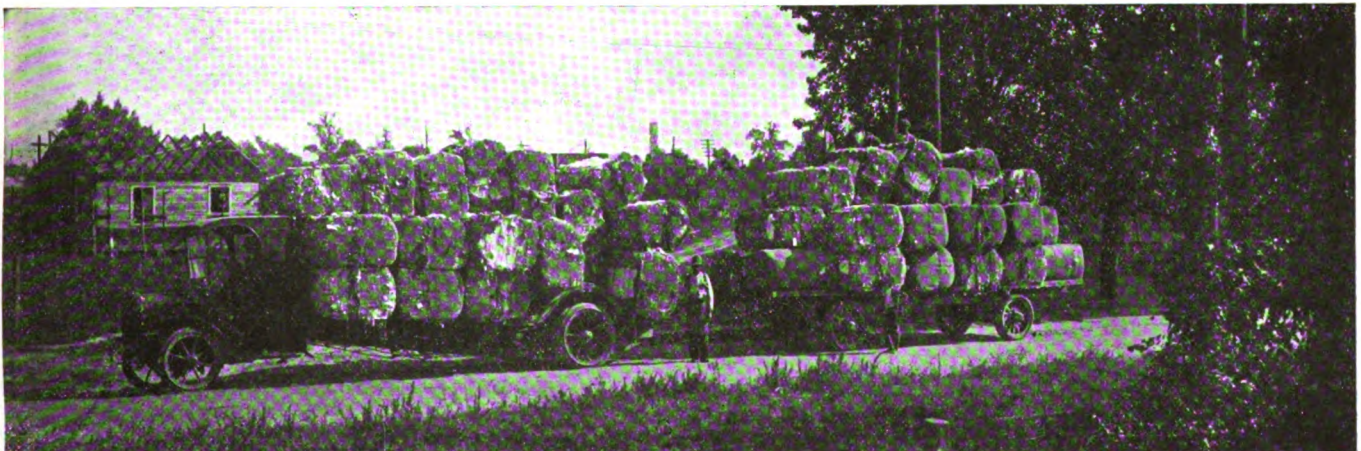

ADVANTAGEOUS CONTRACTS COULD DOUBTLESS BE MADE FOR THE HAULAGE OF SUCH BULKY MATERIALS AS COTTON, ETC., DURING CERTAIN SEASONS OF THE YEAR. THE ADVANTAGE OF THE TRAILER IN SUCH WORK IS MANIFEST



| City | Distance Miles | Per Cwt. | 18 lb. Basket | 25 lb. Basket | Bushel Basket 60 lb. | Bushel Crate 70 lb. |
|---------------------------|----------------|----------|---------------|---------------|----------------------|---------------------|
| Painesville, | 28 | 25c | 6c | 7c | 18c | 21c |
| Perry, | 32 | 30c | 6c | 7c | 18c | 21c |
| Madison, | 34 | 35c | 7c | 9c | 21c | 25c |
| Unionville, | 36 | 35c | 7c | 9c | 21c | 25c |
| Geneva, | 38 | 37½c | 7c | 10c | 23c | 26c |
| Saybrooke, | 44 | 40c | 7c | 10c | 24c | 28c |
| Ashtabula, | 55 | 40c | 7c | 10c | 24c | 28c |
| Return empties, | | | 2c | 2c | 3c | 3½c |

During the winter months a steady flow of winter vegetables, such as mangoes, onions, apples, cabbage will be hauled by this line.

Now that the farmers have become educated to this service, next summer will exceed last Summer's record.

All sections present sterling opportunities for Rural Motor Express systems. A majority of these lines are not in competition with the railroads, but serve sections that have never been served except by horse and wagon, but where they do compete there has been found that there is business enough for both. Rural Express, being a war innovation, coming after the fashion of other necessities, is here to stay, and to do its part in feeding the world and in building a greater United States.

WHEN BEARINGS RUN HOT

Mark Meredith

A wise manufacturer always takes precautions to avoid the bearings in his machinery being heated and takes frequent steps to satisfy himself that the men in charge of this matter are really attending to their duties. If this is neglected very serious damage is involved. Some bearings are normally hotter than other and in some cases a bearing may feel uncomfortably hot to the hand and yet may be quite satisfactory, though this is seldom the case in any clayworking plant where the machinery is heavy and runs comparatively slowly.

Among the numerous causes of hot bearings the following are the most important:—

(a) Lack of lubrication, due either to an insufficient supply of

oil or grease, or to some defect whereby the lubricant cannot reach the part of the bearing where it is required. This defect can be remedied without much trouble.

(b) An unsuitable lubricant such as using a grease where an oil is required, or a thin oil instead of a thick one. In some cases even a slight increase in the the thickness of the oil may make all the difference to the running of the bearings and no pains should be spared to insure a suitable lubricant being used.

It often happens that a cheaper oil or grease may be substituted for the one being used, but the aim should never be to use a lubricant which is sold at a low price, but one which proves to be cheap in use because so little of it is required to keep the bearings in good condition. In many cases the substitu-

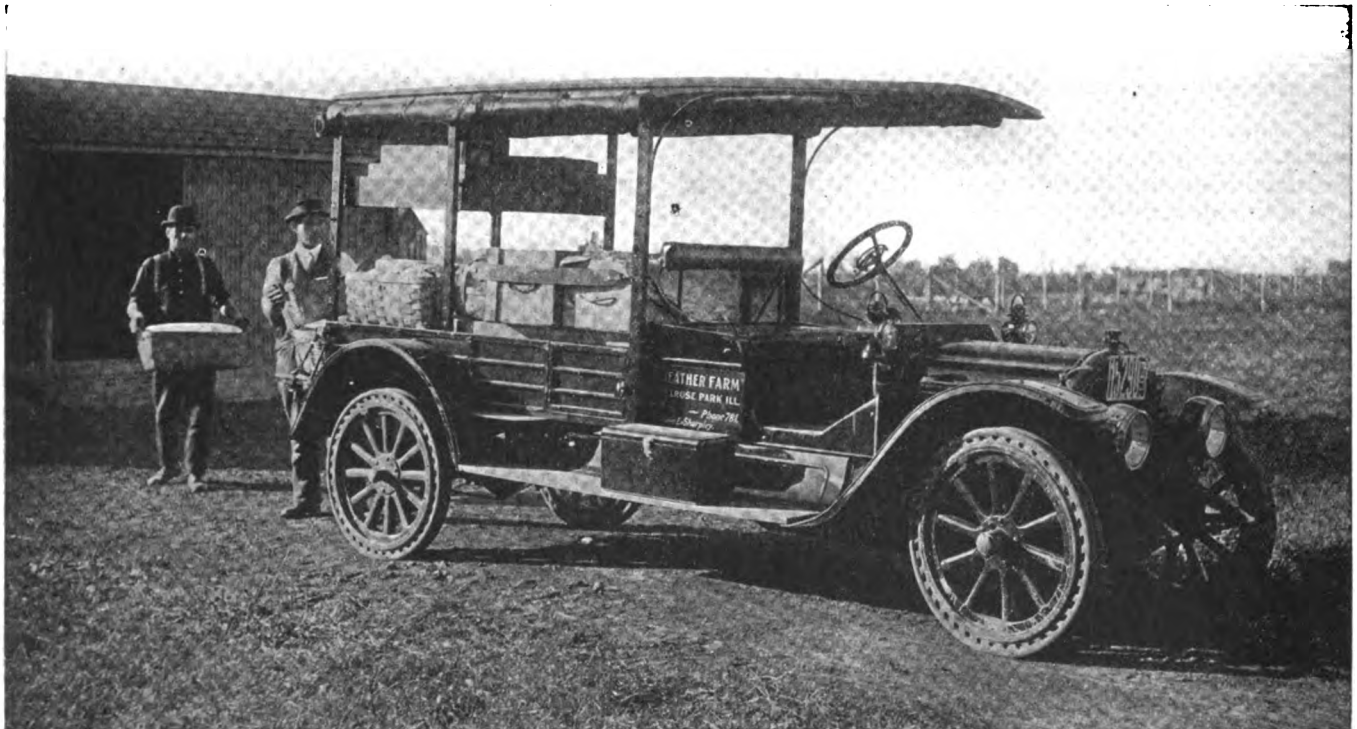

AN IDEAL EQUIPMENT FOR RURAL MOTOR EXPRESS LINES WHERE THE HAUL IS SHORT AND QUICK SERVICE IS DEMANDED. TRUCKS OF THIS SORT CAN MAKE GOOD TIME OVER POOR ROADS AND ARE VERY ECONOMICAL IN OPERATION

tion of grease under light pressure (as in a Stauffer lubricator) will prove more efficient and much cheaper than the use of thick oil. The choice of a lubricant should be based on trials and on actual experience and not on the recommendation of men with little or no knowledge of the conditions.

(d) Dirt in the bearings introduced with the lubricant or in the form of dust. This sets up friction and soon causes an evolution of heat. The remedy consists in cleaning the bearing thoroughly, using a lubricant free from gritty matter and protecting the lubricating hole in such a manner that no dust can enter the bearing. A light cover will often save a large amount of trouble in this respect, particularly in dusty places.

(e) The clearance in the bearing may be either too large or too small. If the former the lubricant will not be kept properly to its work and if the latter there will be in insufficient supply of lubricant owing to the small space through which it has to pass. The remedy in either case is to place the parts of the bearings in such relationship to each other that the correct amount of clearance is obtained.

(f) Lack of alignment will often cause overheating of the bearings, as the machines will not be truly parallel to the driving shaft and the pressure exerted by the belt or gearing will be greater at one part than at another.

(g) Badly made or badly lined bearings usually "work hot" and no amount of lubrication will prevent this. Unless care is taken in relining a bearing the white metal may be left too rough and thus prevent the proper flow of the lubricant or even the total lack of lubrication at certain points because the lining is in contact with the moving part.

When a bearing is overheated the first thing to do is to apply more lubricant and to observe carefully whether this has the desired effect. If not, a thinner lubricant may be applied if the nature of the bearing permits though the use of thin oil is seldom a permanent remedy for hot bearings. If this does no good, the bearings should be slackened slightly as the clearance may be insufficient to permit the lubricant to flow properly. In some cases it may be necessary to slow down the engine until the bearing cools and at the same time to ex-

amine it as far as conditions permit. It is best not to stop the engine or machine entirely as the bearing may then adhere to the journal and it will be impossible to restart it without damage. On no account should a bearing be cooled by pouring water on it. This usually causes such severe contraction that the shell is weakened and may be cracked. If other means of preventing the bearing from being overheated fail, it will be necessary to take it to pieces, examine it carefully and see whether the cause of heating is included in the ones mentioned above. If it is none of these, the case is so abnormal that a specialist will be required to diagnose the cause and provide a remedy.



GARAGEMEN WILL GET FORD PARTS DISCOUNT

Since January 1, any garage has been able to handle Ford parts and secure the regular dealer's discount on them. The Ford Motor Co. has been trying this method out in a limited way and has found it to work satisfactorily, and beginning with the New Year the plan was extended so as to be national in scope. This will not only increase the distribution of Ford parts but will also interfere with the manufacture and sale of imitation Ford parts.

This is only another step in the Ford policy to broaden their sales policy to such a degree as to make their car and its parts almost a matter of general merchandising. The removal of territorial restrictions on Ford sales some time ago was the first step in this direction. With every garage certain of its ability to secure genuine parts at the regular dealers' discount the attraction of handling parts for Ford cars made by other concerns will largely disappear. This will also be a factor in increasing the ability to obtain service on the car, since repairmen need not be delayed in securing parts, as they will now be able to carry them in stock. There is no restriction imposed on the garagemen regarding the number of parts nor the amount of money he need spend in laying in a stock.

A NEW USE FOR RUBBER—AS A VALVE SPRING.

In the winter of 1905-1906 when the two cylinder opposed was "the thing," I was employed by a concern down in the Pecos River Country, 250 miles southeast of Albuquerque, N. M., on a Government mail route. The distance between terminals was 111 miles. A ranch house 15 miles from the south end and another ranch 18 miles from the north end were our neighbors

on the route, no phones, no other roads of any description, nothing but a vast waste of sunburned grass weeds and sand, and uphill 3,200 ft. in the last 30 miles.

I left the south end at 1 P. M. and was due at the north end at 6 P. M. I had twenty-four sacks of mail and one passenger (a minister). After getting out about 35 miles we ran into mud and it was all I could do to stay in the "High" with my load. After about 5 miles of this there was a sudden noise, the car bucked up and stopped dead. It took some time to discover what was the matter, and when located explained why the car "bucked." The exhaust valve stem had broken where drilled for the pin that held the valve spring. I took out the broken exhaust valve and cut a blind gasket from pasteboard box, which held my passenger's lunch, and inserted in intake manifold and started up O. K., but could not put the load on the high. Sixty miles on the low was too much, so I took inventory and started to work again. Removing the intake valve I put it in place of the exhaust, took the broken valve and an old file and made a groove around the stem, about an inch from the end. After inserting this broken valve in the inlet port, I drew a piece of bailing wire into the groove as tight as possible; then removed the adjusting screw from the push rod so it would not interfere.

There was no spring nor wire to make one that would do for an automatic intake, so I took an inner tube and cut a piece out of it 2 in. wide and about 10 in. long, wrapped this around the valve stem and bound tight over the wire ring with cord which prevented slipping off; stretched the rubber back and fastened to an oil lead pipe in line with valve. After removing the "blind" gasket I had inserted in the intake manifold, I cranked up the engine and the rubber intake worked perfectly, in fact could not be noticed, and it was the "high" for us on to the north end.

This repair was made in about two hours including the first project which failed.—M. S. Walton, Cal.

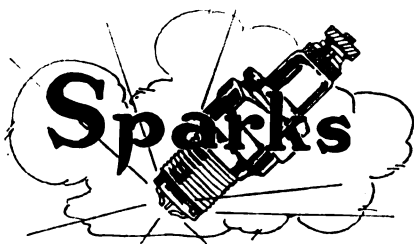

Concerning what to do with the Kaiser everybody thinks like the Missouri juror who was convinced that he ought to be hung after a fair trial.

The fact that dead men tell no tales probably accounts for so many widows getting married again.

Most peoples' idea of musical skill is to be a soloist on a cash register.

There are queer things on the cards these days—the deuce is taking all the kings.

Some people have the idea that a bargain consists in paying fifty cents to have a fortune teller tell them that they will get \$100,000.

Any Bidders? "Wanted — Men to shingle."

They say that a man named J. K. Sniffer has the garbage contract for Omaha.

The women profess to be shocked on finding that wicked men spend their time betting on whether this or that woman wears one or two petticoats or none. Does this discourage the fashion? It does not "How do they settle the bet?" we think we hear. Easy, madam, that's easy.

Quick Watson! "The third part of 'Ghunga Din will be shown at the Temple theater tonight."

Figuratively speaking—a lecture on mathematics.

Shakespeare says that all the world's a stage but a lot of us are poor actors.

There won't be any fun painting the town red if we've got to use water colors.

You never can tell. Even the fellow who brags about his cold cash may be spouting hot air.

Bluff carries many a man to success but he generally has to hoof it home.

It's a good thing Methuseleh wasn't a woman or we never would have found out how old he was.

It's one thing to preserve your equilibrium but its quite another matter to keep your balance in the bank.

There are lots of fossils that haven't been placed in the museums. Some of them are still walking around.

It Can't Be Done—The man speeded up to see if he could beat the train to the crossing. He couldn't.

The man struck a match to see if the gasoline tank on his automobile was empty. It wasn't.

The man thought his car was faster than the speed cop's motor cycle. He was wrong.

Wonder how the fellows who married to escape the draft feel since the war caved in on them.

When you hear a veteran of the great war telling about coming through without a scratch. He's a liar. They even say they have discovered why pictures of Napoleon show him with one hand under his shirt.

Just now the world seems to be made up of two kinds of people—heroes and zeroes.

Buy your thermometers now, they'll be higher next summer.

After the Sinn-Feiners organize their Irish republic what are they going to do with it?

The great problem just now seems to be to make Germany safe for the Germans.

Wonder if the senators who objected to the President going to Europe will object to him coming back?

Some people talk incessantly only to keep you from finding out that they have nothing to say.

It was only half as hard to swear off this year as usual—the country goes dry on the first of July anyhow.

Even when a man rests on his laurels he may suffer from insomnia.

The egotist is never blind to his own interests. He has capital I's.

You never can tell. It's the sure things that make life so uncertain.

An ability to coin words won't get you a job in the mint.

Treat 'em Rough was the battle cry of the tanks. The prohibitionists are now taking up the cry.

Marry a girl who believes in love in a cottage. It's a cinch you can make her believe anything.

Time is money: so don't waste your time trying to borrow money from a fellow who hasn't any.

Even when they attempt to count the cost some people are mighty poor at figures.

It certainly does seem as though the colors that run ought to be the fastest.

Time is money: so it's no wonder some people buy on tick.

With some men the greatest pleasure that comes with success is the ability to inspire envy.

You never can tell. The woman who writes articles on how to choose a husband may never test her theories.

It is just as essential to know when to quit as when to begin, even the easy going fellow may be hard to stop.

Giving an eye for an eye—when two egotists meet and begin a conversation.

Gossip never dies from lack of circulation.

All is fair in love except the actions of the other fellow.

Two heads may be better than one—but not in the same family.

The man who sows seeds of courtesy and kindness will reap an abundant harvest.

Lots of people would starve if they

THE MONTH'S BEST CARTOON



THE NEW GERMAN WAR SONG.
—KNOTT IN THE DALLAS NEWS.

were to sit down and wait patiently for the return of the bread they cast upon the waters.

Some doctors who take life easily escape arrest.

Some men lose their hats at elections and others lose their heads.

A fool may be able to answer questions that a wise man wouldn't ask.

True friendship results from a compact of frankness and forbearance.

There are times when the world seems very small—one of the times is when you are trying to dodge your creditors.

According to law a widow is entitled to her third but after the funeral of her second, men are apt to be a little shy of her.

Poison to anarchy—a square meal. We wonder whether it will be a league of peace or a piece of a league.

The Russian bolsheviki have plenty of money, such as it is. They are running the printing presses 24 hours a day.

The sultan says Turkey got into the wars as the result of a mistake. We would say it was the result of poor guess work.

Evidently, from the latest German election reports, the Spartacans can't.

One of the best methods for preserving a good complexion is to keep the jars air-tight.

When the government takes over the railroads and we have prohibition a lot of people can quit lecturing on the subject and go to work.

It's a good thing society is shallow or lots of people who are wading around in it would be drowned.

A bolshevist is the man that sees only the ruction in reconstruction.

The Kaiser always said he received his crown from the Lord. "The Lord giveth and the Lord taketh away; blessed be the name of the Lord!"

It begins to look as though all the titular bunk, gewgaws and bull that have characterized royalty and nobility for fifty centuries will soon exist only in our fraternal orders.

Licking war savings stamps leaves a pleasant taste in the mouth. Try it.

The league of nations idea is a good one provided the umpire question can be satisfactorily settled.

Men pray for what they want and Providence makes them sore by handing them what they ought to have.

The war hasn't started yet for some of the fellows who are expected home soon. Well anyhow the title Crownless Prince is a welcome change.

We wonder whether there's just going to be one league or a Major League and a Boche League.

William Allen White tells us that after we get through forging our swords into plowshares that we'll have to straighten out our corkscrews into hatpins.

A southern newspaper is so cruel as to remark that there would have been no opposition if it had been Congress that was going out of the country.

Why is it that a man who is sensible enough in other ways will try to see how close to the danger line he can get without stepping over it?

Another trouble with Prohibition is that a fellow will have to go all the way out to the Zoo when he wants to see snakes.

The reason some girls are afraid of mice is because they are wearing their best stockings and there's a man around.

The Correll Shop & Store.

Dealers in "Everything the Farmer Uses".

TIME TO OVERHAUL MACHINERY.

The proper time for overhauling either the auto or the farm tool is during its 'period of inactivity' and before the rush of Spring work.

If put off until needed, delay incident to getting repair parts promptly, press of other work, and the hazy recollection of half-forgotten difficulties hinder the efficient prosecution of this work.

Right now, it would be well worth while to make out a schedule of needed repairs and adjustments for each particular machine and to come in and get the needed parts, so that when opportunity arises the work may be taken up and the tool put in first class shape.

Let's get together on this proposition and save a lot of 'rush' and possibly some delay next spring.

Very truly yours,
Correll.

The 'Non Glare Laws' for Autos are still in force in Illinois and Indiana. But for some reason our trade on these 'dimmer glasses' has not been so brisk as we expected, and we've decided to discontinue handling them.

We have 7 pairs of high grade dimmers on hands and to get them off our shelves before February 1st we'll price them at 98 cents a pair. We'll lose 50¢ but you'll save 100%, and we need the room for other and more salable goods.

When business shows signs of curling up and going to sleep for the winter, Fred Correll begins to monkey around with type case, composing stick and printing press and the result is usually something worth while and appropriate to the occasion. Every shop in the country could benefit by calling the attention of their customers by some such means. Notice the statement: "We solicit your patronage on the basis of the fact that even if you did pay us more money, the job would be worth it."

ALUMINIUM ALLOY

Aluminium was merely a scientific curiosity a generation ago, the production in 1883 having been but 83 lbs.; but it is now one of the most common metals in use, with an annual production of hundreds of thousands of tons. It is most important in its alloys, especially in those with magnesium and copper. The alloy known as magnalium is a series of mixtures containing 10 to 30 per cent of magnesium; it is silver-white in appearance, strong ductile, easily cast, takes a fine polish, and has a specific gravity of only 2 to 2.5—somewhat less than that of aluminium itself. With 10 per cent of magnesium the melting point is between 650° and 700° C. The metal is made harder, more brittle and finer in polish with additions of magnesium up to the practical limit of 30 per cent; it may be given a dark color by maceration, or it may be nickelled or gilded. Duralumin, with 3.5 to 5.5 per cent of copper and about 0.5 per cent each of magnesium and manganese, has greater hardness, tensile strength and ductility than any other aluminium alloy. It takes a high polish and may be easily hardened, but it is given special value by its resistance to the action of sea water, and dilute acids. It is a little heavier than

The Correll Shop & Store.

Dealers in "Everything the Farmer Uses".



It Is Also Time To Put 'Non-Skids' On The Horse.

'Cause, one of these mornings we're going to wake up and find the roads "rougher'n the dickens".

Our charges for shoeing the Driving Horse are no higher than at the other shops around us, and yet we solicit your patronage in this department on the basis of the fact that even if you did pay us more money, the job you'd get would be worth it.

For we pay particular attention to the FIT and FINISH and EASE OF TRAVEL on each and every job.

Very truly yours,
Correll.

PRICES, - for plain shoes and ordinary work, - 1's, 2's and 3's - \$2.00; for 4's - \$2.25; 5's - \$2.50; 6's - \$2.75, and 7's - \$3.00. ("Special work" and mean and vicious horses will be charged 'extra').

A USEFUL DEVICE

Engineers who in renewing a gauge glass under steam have seen it crack on the introduction of hot water, will be interested to know how to avoid this accident which may happen with the last glass in stock. Get a bit of 16 or 17 gauge copper wire, some inches longer than the glass tube, and coil the ends in spirals that will just entirely cover the tube—about 4 turns at each end, leaving the last of the wire in the centre. The hot water may then be turned on with safety. The cooling effect of the copper on the water is sufficient to save the glass, and the experiment is compared with that of putting a silver spoon in a thin glass when filling it with hot water.—Mark Meredith.

Automobile traps were the inspiration of a perfectly respectable citizen of Cobourg, France. His idea had birth in 1900. Later, after he had tasted the pleasure of motoring, he lost much of his former enthusiasm for his project.

Benton's Recipes

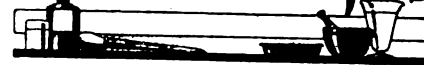

Lubricant for Lathe Centers—An excellent lubricant for lathe centers is made by using 1 part graphite and 4 parts tal- low thoroughly mixed.

Cement for Switchboard Repairs.—A good cement for making repairs on switchboards, when iron or other metal has to be fastened to marble, or where binding posts have been pulled out, may be made to consist of 30 parts plaster of paris, 10 parts iron filings, and 1/2 part of sal-ammoniac. These are mixed with acetic acid (vinegar) to form a thin paste. This cement must always be used immediately after being mixed, as it solidifies if allowed to stand for any length of time. It will be found to be an excellent means for filling up old binding-post holes, when instruments have been moved.

Preparing Glue—Glue cannot be prepared by any fixed rules, for the reason that there are so many different grades. Again, glues differ in the relative proportion of water and glue. For instance, a certain kind of glue taking two parts of water for every part of glue would give unsatisfactory results if three parts of water were added. Some grades require three parts of water, while others can stand but 1 1/4 or 1 1/2 parts per part of glue. The viscosity of the glue solution usually indicates the relative proportions of water and glue. This test requires experience. Have the manufacturer from whom you are buying the glue inform you what proportions will give most efficient results, then weigh the water and glue and do not mix otherwise than directed.

After the glue has been properly soaked, it must be melted by the application of heat. This is the most important part of the process. The words most important are used advisedly. It is safe to say that most of the damage done to glue is done in the melting process. There are all kinds of ways of melting glue, but many of them absolutely ruin the glue.

Copper Coating Solution. A copper coating solution for use when laying out work on iron or steel which I have found more satisfactory than the ordinary blue vitriol is a mixture of saturated solution of zinc chloride with a very little copper sulphate added, say a half-dozen drops of copper sulphate to a spoonful of zinc chloride solution. When a piece of steel is rubbed with waste moistened in this solution it produces a bright copper surface that does not easily rub off.

Silvering Process.—Brass and copper articles can be given a silver coating by first cleaning them thoroughly and then moistening and rubbing on a little of the following mixture: Three dr. of chloride of silver, 20 dr. of powdered cream of tartar, and 15 dr. of well-powdered common salt. After applying rub with prepared chalk on a cloth, finishing by washing with water and polishing with a dry cloth.

Building up Bearings.—The following suggestion is made by a workman, for adjusting the small ends of connecting rods where considerable play exists: Press the bushing out of position in the vise and sweat a layer of solder onto the outside surface. After pressing the part into position again it will be found to be smaller than before and the wristpin can be refitted.

EASILY MADE WORK SUPPORTS

These two ideas are simple, yet very useful for supporting long bar stock, pipe, etc. The floor stand is made of 2-inch pipe, one end of which is split and spread, and then



moulded in cement. The V or U shaped jaws are made by splitting long bolts with a hack saw and bending to desired shapes. A nut and a washer give the desired adjustment for height.

The bench or vise work support is bent up from one piece. The sketch explains the idea clearly.

TAPER JAW ATTACHMENT FOR VISE

This device is a home-made affair to be used with the solid or non movable jaw type of bench vise. It converts that sort of vise into one that will hold any sort of tapered work.

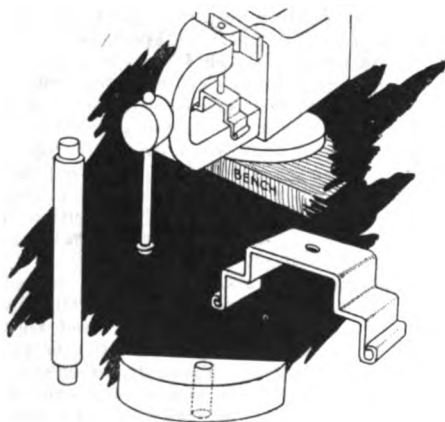

The sketches show how the attachment is used and its construction in detail. There are no dimensions given, for it must be made to suit the vise.

The half round jaw should have slight serrations or teeth, on its face to aid in gripping the work, also it should be of good steel, tempered and hardened.

UNIQUE WASHER HOLDER

This idea of the writer's for holding various sizes of round washers is one that will appeal to all, for the washers are quickly and easily put in and taken out, and the holder revolves suspended from the wall bracket so that any size can be easily found.

To make it is but a simple task. The first thing to do is to select a couple of pieces of two-inch plank, nail them together, and lay out the holes. This is done as follows: Scribe the circle for the outside diameter as large as the desired holder is to be, then scribe the various washer holes a reasonable distance apart, and so that their outside edges will all come on the edge of the large circle. Then bore each hole and when finished saw out the holder so that the

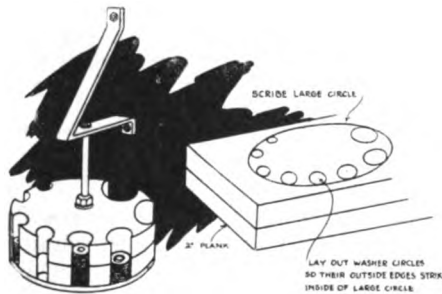

outside edge of each washer hole is cut open. Make the wall bracket; nail on a base board; put in a long center suspension bolt, and the holder is complete.

BENDING ATTACHMENTS

I noted a few handy devices that one blacksmith used to make bending various sorts of stock over the anvil horn.

The sketches show these attachments. A hole was drilled and tapped in the side of the anvil below the horn, and these devices screwed in, as shown.

These same attachments can be used at the bench vise by tapping a hole for them in the lower part of the vise and using a piece of stock in the vise jaws to bend over.

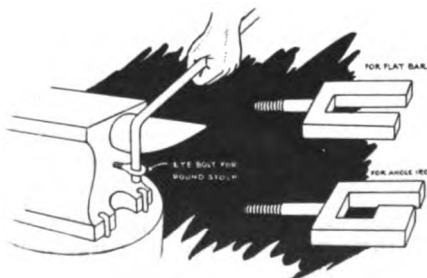

The Kink and

Char

A PERMANENT FEATURE

We plan to make this department a regular and permanent feature of this magazine. To do this we will necessarily need the co-operation of our friends and readers.

Spend a few profitable minutes putting your ideas on paper and then send it along with enough of a description to tell what it is for and how it is made.

There are hundreds of good ideas knocking around the shop that you can think of that will fit in this department. A junk pile don't have any value unless you sell it.

Let us be the judge of whether it is good or not.

KEY EXTRACTOR

The writer conceived the idea for the design of this key extractor when experimenting in making such a tool in spare time. It is made from a good quality machine steel bolt, one end of which is drawn out flat and offset. A hole is drilled

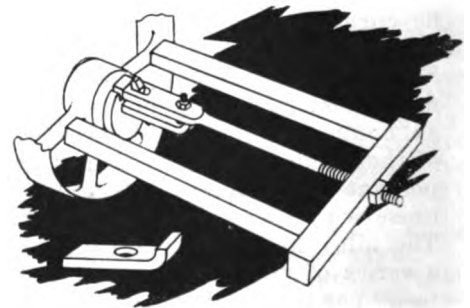

and filed in the flat portion to fit over the key head. A strap, as shown at A is made, and with this, the key is clamped into the hole of the extractor, as shown. A suitable strongback and distance pieces complete the device.

It is questionable if in any other department of the car it is more essential to use the stitch-in-time doctrine than with the battery. A little attention may cost you not more than \$2 or \$3, but if you let the trouble go too long your repair bill may be \$25 or \$30. It will not take more than three or four days to insure yourself that your battery is in proper condition, and it is worth while to get it in this condition before the start of the season.

Top Note Corner

Willey

LENGTHENING TWIST DRILL

There are times when one wants to use a drill in some place that require its being extended. Of course all blacksmiths can weld on an extension, but it is not always desirable to do this, for it means that

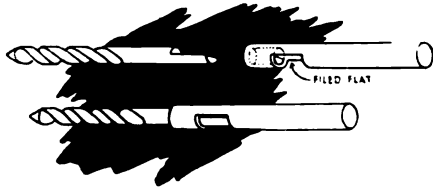

the drill then can only be used for such work that requires a long shank. The sketches show a very practical way to easily and quickly extend a drill shank and yet not spoil the drill for use in the regular way.

SKELETON WRENCHES

Where there is much overhaul work on small engines and machinery, there is need of a set of skeleton wrenches for holding check nuts, and for light weight wrenches when running off and on

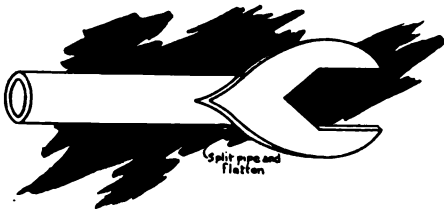

the bearing nuts. For small nuts up to 1½-in. such skeleton wrenches can be made from steel pipe by splitting one side and opening it out flat, then cutting and filing to fit the nuts.

HANDY HOME MADE DEVICE

During a recent visit to a small shop I noticed this rig that they had devised for straightening and bending shafts, plate and other stock.

While it is rather a crude appearing affair it answered the need of a bending rig, it consisted of short lengths of I beams a couple of tie rods and straps the rough sketch gives one the idea, the screw jack was held upside down to the bottom of the top beam by a couple of cap bolts that were tapped into the base of it.

Vee blocks set on the face of the lower beams held shafts for straightening, while any section of

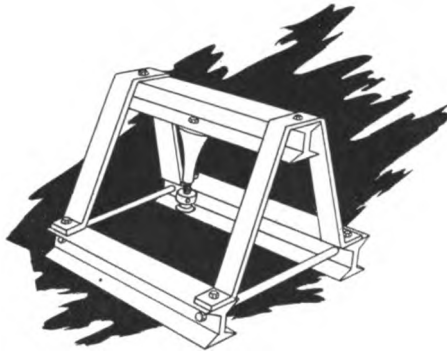

a truck or car frame could be placed right across the beams and the pressure of the jack quickly applied.

Holes drilled along the upper beam permitted shifting of the jack when needed.

MANIFOLD PORTABLE LIGHT PLUG BOARD

A very handy multiple connection board for shop use. Where electric tools are used it is often desired to use a couple of portable lights, a soldering iron, and an electric drill. When there are not enough tap sockets at hand, this device will be found to be worth constructing. It consists of a hardwood board grooved on the one side to receive the two wires; a set of holes are drilled and long

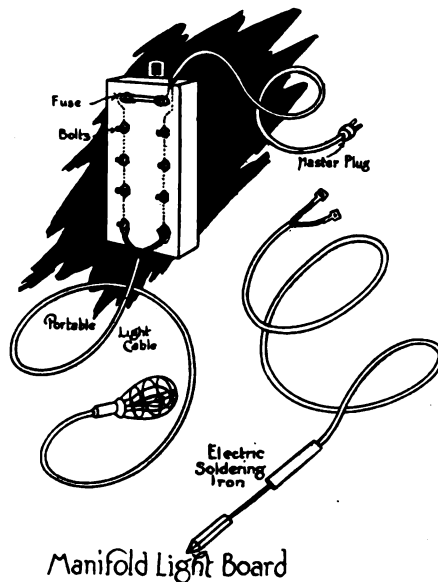

small size bolts used for connectors. A fuse fitting is used at the top to take care of short circuits. Anyone familiar with wiring can fit up such a board.

IMPROVISED BEARING OILERS

When there is need of extra bearing oilers or ones to replace those lost, perhaps the two kinks shown in the sketches may come in handy. The material for making them can nearly always be found

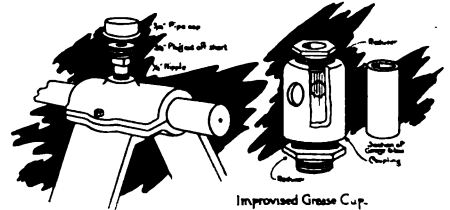

among worn-out discarded fittings in the store room.

The sketches seem to be self explanatory, and as the dimensions of fittings are governed by the bearings, none are given in the sketches.

AN EFFECTIVE ARBOR PRESS

In shops where automobile repairing is done, the need of an

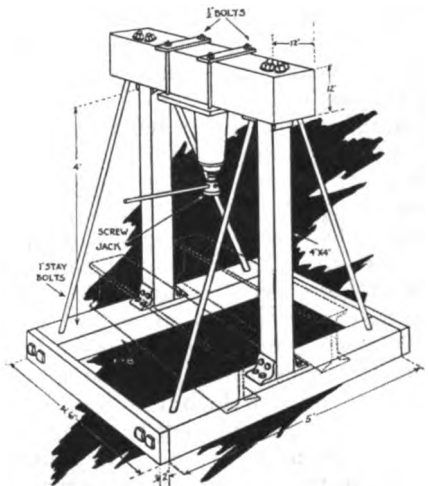

arbor press is frequently felt to remove axles, gears, bushings and other parts that are assembled with force fits.

A cheap and simply constructed press that will answer all purposes in a satisfactory manner is made as illustrated from a screw jack, several pieces of timber and two lengths of steel "I" beam. The dimensions can be altered to suit individual requirements. Instead of the screw jack, one of the better known automobile type can be used if it is sufficiently heavy to do the work demanded. A simpler method of suspending the jack can easily be worked out so that the jack can be easily and quickly removed for other work about the shop.

Brakes and How to Adjust Them

M. H. GEORGE.

This all important and much neglected part of the automobile mechanism is treated in Mr. George's characteristically thorough manner.

Brakes are one of the most neglected things about an automobile, and they should have a good deal more attention than they usually get and should always be in working order as one never knows when they will be needed the worst way. In many garages the men do not know what the adjustments on the brakes are for different cars. I am going to try and give them here for a number of different cars and also some helpful advice on lining them.

In lining brakes either on a cheap car or the most expensive one, use a good grade of lining and the right width and thickness. If this rule is not followed trouble is sure to result. I remember once, a number of years ago, when we did not have as good a supply of brake lining as we have now, that a car came in to have its brakes lined. We had the right width but it was too thick. We put it on and supposed that the extra thickness would be taken care of all right, but here was where we were wrong. We could not get the wheels on in any way. We tried grinding the lining on the emery wheel and did manage to thin them a little but it was not a job that we could look back on with pleasure and pride. One other time a wide lining was narrowed down with the tinner's shears and this did not prove all it was cracked up to be. After this the orders were to first see whether we had the right thickness and width of lining and then go ahead and put it on.

One should be very careful to get the lining on smooth, and have it fit tight to the band. In putting the lining on the inside of a thin steel band, it is best to cut the lining an inch or more longer than the band, then rivet one end. Now take the band and pull the two ends apart just as if you were breaking a wish-bone, at the same time slide the lining down towards the end that is hitched with the rivets. If it cannot be held long enough to get a rivet or two in place, tighten a clamp on this end and then rivet

it. After this the other rivet can be put in. This stretching applies to any brake band that will bend easily. On the heavy cast ones the lining will have to be pulled on as tightly as possible then begin at one end and rivet the lining down tightly. It is a good idea to get all the rivets in and head them a little and then finish them all up. The heads of the rivets are on the lining side, of course, and after they are all tight, take a ball-pein hammer and set the heads of the rivets into the lining. The other side should be held against something solid. The brake lining companies publish a chart with the dimensions of brake linings for all different makes of cars and it is well to consult these before replacing linings as it gives the length, width and the thickness that is best to use on that car. Do not use a thicker lining than is recommended without being sure that it will go as it makes a bad job. One

needs the ends of the brake band. The emergency brake is inside of the brake drum and is operated by the hand lever. Adjustment of this brake is made by adjusting the pull rod yoke ends. The brake should be kept clean and free from oil or grease. If they do get oily, they should be cleaned off with gasoline. The Saxon Four-Cylinder cars have the same brake adjustments.

The external brakes on the Buick Six are operated by the right pedal on the driver's side. These brakes are adjusted by turning up the thumb screw and lock nuts at the opening in the band and by means of the adjusting screw in the anchor pin at the rear. The bands should be adjusted to allow a uniform clearance of 1-16 inch between the lining and the circumference of the drum, when the brakes are released. The throw of the brake levers and the position of the pedal can be adjusted by means of the turnbuckles in the brake rods. The

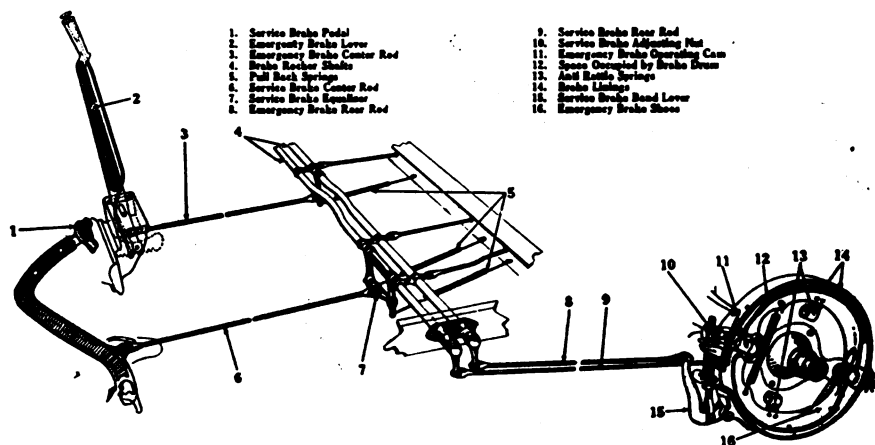

Overland Light Four Brake System.. This system varies but little on all other Overland and Willys-Knight Models

will usually find that the wheel will go on a great deal easier if the adjustments are loosened, up or else a pin taken out and a rod unhitched and left until the wheel is in place.

The service brakes on the Saxon Six are controlled by the foot pedal. These are the ones on the outside of the brake drums.

The adjustment is made by adjusting nut on short rod which con-

nects the ends of the brake band. The emergency brakes are the internal brakes and will not wear as much as the other ones but when they do need adjustment, this can be made by shortening the rods with the turnbuckles in the rods.

On the Chevrolet Four-Ninety the rods connecting the foot pedals with the brake shaft on the propeller-shaft housing are provided with turnbuckles. By turning these the rods can be shortened or

lengthened, which in turn tightens or loosens the brake bands. Do not adjust the brakes too tight, for if you do they will drag and cause the drums to heat.

Should one brake grab, or take hold too quickly remove the brake operating cable yoke pin on that side and shorten the cables by screwing up the yoke ends. The Chevrolet model F. A. has the same adjustments and are taken up in the same way.

The Chandler Light Six has two sets of brakes operating on the drum at the rear wheel. The service brake is operated by the right hand foot pedal. This is the external brake. The emergency brake is the internal one and is operated by the lever. These brakes when they are properly adjusted should clear the drum by about one thirty-second of an inch.

Most adjustments, when necessary, can be made with the aid of the adjusting thumb screws, mounted on the front of each brake band.

The clevis pin connecting the two ends of the brake shoe is threaded and before any adjustment can be made the lock nuts must be loosened, then the thumb screws may be turned down two or three turns, if it is needed, then the lock nuts should be tightened again. If one brake does not take hold at the same time as the one on the other side of the car, disconnect the brake pull rod (underneath the car) leading to the brake shoe lever on that side, and thread the yoke further down the rod a distance sufficient to shorten it as required, or in the event the brake shoe on one side may be up too tight, the pull rod on that side may be lengthened to correspond with the rod on the other side. Other adjustments may be made by shortening the length of the brake pull rod attached to the foot pedal, disconnecting the yoke and turning the same three or four turns to the right before re-attaching. When making this adjustment be careful to see that the pedal does not ride on the floor board, holding the brake in a partially applied position.

The emergency brakes are adjustable by means of the turnbuckles located in the center of the rear pull rods. The turnbuckles are locked with the aid of a locking nut, which will have to be loosened before the turnbuckles can be moved. The brakes can be made tighter

by turning the turnbuckles to the right a turn or two. In relining these brakes or brakes on any other car, the lining should be held on with copper or very soft iron rivets. If the brakes should suddenly go wrong and not hold one may find that the rear axle has changed its position slightly, due to the spring clips having become loose.

makers do not put equalizers on both the service and emergency brakes, some high priced and high class cars do not have brake equalizers, it would not cost any more to put them on and they are a mighty fine thing. The service brake is adjusted by the nut at the front of the band, this makes the band come nearer the drum, when the nut is

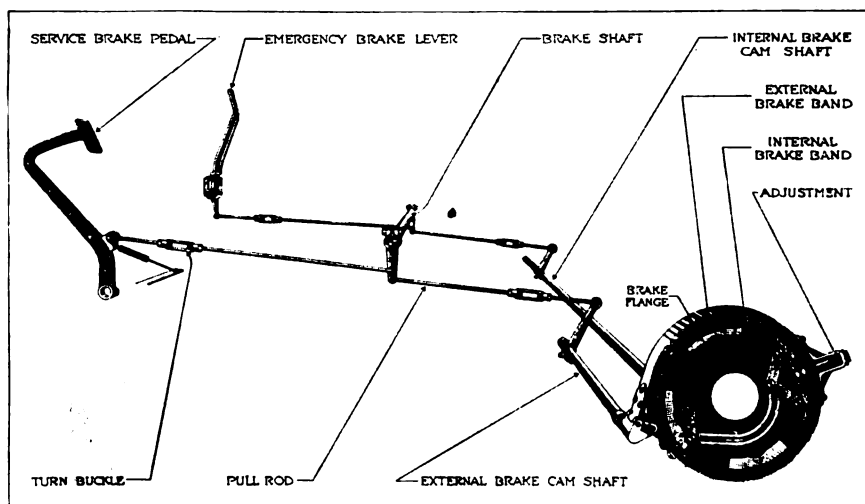

Brake System of Buick.

The rear axle is held to the spring seat by means of the spring clips. If they should become loose and allow the rear axle to change its position even a little it would make quite a difference in the workings of the brakes.

On the Maxwell 1918 models there will be found on one end of each brake pull rod, running from brake cross shafts to rear axle, an adjustable yoke, or clevis. These furnish the adjustment for equalizing the brakes. Under the floor board is a turnbuckle in each brake rod which provides for tightening or loosening the brakes. Never drive the car with one brake that goes on before the other as this will cause the car to skid badly and may be the cause of an accident.

The Chalmers "Six-30" brakes are very simple to adjust. The ordinary adjustments can be made on the service brakes by means of a lock nut adjustment at the front of the brake band. Adjustment of the emergency brakes consists in drawing in or lengthening the two brake pull rods by means of a threaded brake pull rod adjustment.

The Studebaker service brake is provided with an equalizer, this is so that pressure on the foot pedal is equally distributed on both wheels. I do not see why the car

turned to the right. The band is held away from the drum by three springs and there are three adjusting screws, if the band is too far away from the drum these screws can be turned in and this will make the band come nearer the drum. If the band is too near the drum, turning the screw out will let the spring hold the band away from the drum. Jack the car up while making the adjustments and a good rule to go by is to spin the wheel with the hands and if it coasts any distance at all it will not drag enough to do any harm. To adjust the emergency brake proceed as follows.— Take the front floor boards out and you will see the front end of the long rod that goes to the emergency brake, this is attached to the lower end of the hand lever by a clevis. Take the cotter pin out of the pin that goes through the clevis, and then remove the pin. You will see that the end of the rod is threaded and the clevis turns on that. To make the brakes go on quicker turn the clevis on to the rod to make the rod shorter. It is best to have the wheels jacked up so that you can see what you are doing. Be sure and replace the cotter pin in the pin that is through the clevis.

The Dodge car service brake has three places for adjustment. Be sure that the brake supports are

adjusted so that the band takes hold evenly and all the way around. The brake band has a rear support that pushes the band nearer the drum, this is the first adjustment to make. Be sure not to push this up too tight, but just enough that you can feel it when turning the wheel. On the front of this band there is a winged nut that will cause the band to fit nearer the drum when tightened up. Under this there are two other nuts that will lift the lower end up from the drum or make it run closer. There is also a top brake support. This keeps the band from rubbing at the top. The inside brake has no adjustment at the band, there are two little springs that help to keep the band from touching all in one place. The front ends of the brake rods have clevises that can be turned on to the rods farther to make the brakes go on quicker.

The service brake on the Franklin series nine car is operated by the right foot pedal. It has a single drum of chilled cast iron, this is just back of the transmission on the drive line. Sometimes the brake band wears so that the pedal strikes the floor board, when it does it should be taken up. To tighten this brake the wing nut should be turned to the right until the brake is on when the pedal is within two inches of the floor boards. Be very sure that this brake does not drag as it might start a fire that would be hard to put out. If this brake chatters when it is put on, it may be that the lining is badly worn, if not a little oil or graphite applied to the drum will stop it. The emergency brakes act on drums on the rear wheels and are operated by the hand lever. To tighten them you first jack up both wheels, then set the hand lever up eight notches and tighten each brake so that it holds each wheel alike. Tighten the lock nuts when you are through and then they will stay the same. To reline these brakes it is not necessary to take the wheels off.

The service brake on the Dort car is of the external contracting type, on the drums on the rear wheels. They are adjusted by turning the nut at the front of the brake band. Adjust both brakes the same and you will find that one full turn makes a big difference. These brakes have an equalizer. The emergency brake is an internal expanding type that works on the inside of the drums on the rear

wheels. To tighten these brakes remove the clevis pin, loosen the lock nut and turn the clevis on to the rod from the pedal to the rocker shaft. There is another adjustment on the two pull rods that go from the rocker shaft to the rear axle.

The brakes on the Metz "Twenty-five", can be adjusted by taking out the cotter pin and driving out the cam which connects the brake rod to the lever that goes to the band. The cam can then be turned up or down on the brake rod in order to effect the proper adjustment. After doing this connect them up and be sure and replace the cotter pin. The expanding brake can be adjusted by taking off the nut that holds the internal brake

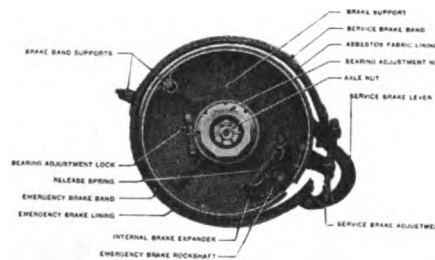

The Chalmers Brake Drum.

stud sector. The sector can then be moved outward allowing the cam to be turned to either loosen or tighten the band as you want it. The contracting brake band can be further adjusted by loosening the lock nut that is on the adjusting rod. The adjusting nut can now be turned to either loosen or tighten the brake band as is wanted.

On the Overland Light Four the foot brake is the one that is used when driving, this contracts the brake band on the outside of the drum. The hand brake expands shoes that are inside of the drum. The brakes should be adjusted evenly so that the brakes will go on evenly on each wheel. The service brake has an equalizer so that one need not be as careful in making the adjustments. The emergency brake shoes are adjusted separately. This adjustment is made by varying the position of the brake operating levers on the slotted clevises of the brake cam shaft. The adjustment of the service brake is made by changing the adjustment of a similar lever or by advancing or backing off an adjusting nut on the service brake band operating link. Before making this adjustment raise both wheels so that they are free to turn. Make these adjustments so that the wheels will turn

easily when the brake levers are off. If the bands get greasy the grease should be washed off with gasoiline. One thing that a great many people do not do that I think a mighty good thing to do and that is to put a few drops of oil on the numerous pins that work the different parts of the brake. Sometime the garage man will find these pins so badly rusted that they can be gotten out only by drilling. To reline these outside brakes it is not necessary to remove the wheels but it is to reline the inside ones.

On the Hudson Super-Six the emergency brake is of the internal or expanding type. These brakes work on the inside of the drums and it is therefore necessary to take off the wheel to make any adjustment to the band itself. For most adjustments all that is necessary is to shorten the rod that goes away from the brake. This adjustment should be made when the wheel is jacked up so that you can tell when it will begin to drag. These brakes do not have equalizers so that the rods must be shortened alike. The external brakes are operated by the foot pedal and the band bears on the outside of the drum. The Hudson people did a good thing here as these brakes are subject to more wear than the other ones the adjustments are much easier to get at. The adjustment is as follows—Take out the clevis pin that holds the rod to the short lever, this will let the short lever fall back to the bracket, now loosen the top adjusting nut two turns, now loosen the lower check nut, this is the lower one and is the smallest. By turning this nut up it will bring the lower side of the band closer to the drum. When this is drawn up as close as you can get it so the wheel will not drag, be sure and tighten the check nut. To adjust the top half turn the big nut at the top of the bolt that the nuts are on that you have just been turning. Turn this down until the band is as close as it can be to the band and still not drag. It is best to adjust the lower half before adjusting the top half. Do not try to adjust these brakes until you disconnect the rod from the short lever. The back part of the brake can be set up nearer with the adjustment that will be found at the back.

There are two pairs of brakes on the Cadillac "8", the service brakes are operated by the right foot pedal, these contract on the

outside of the drums. The ones that are attached to the hand lever expand inside of the drums. Both of these brakes have equalizing bars so that the tension will be even on each drum. To oil and also in making the adjustments of the internal brakes a small cover has to be removed from the outside of the brake drums. These brakes should not be adjusted by taking up the pull rods as this does not have the desired effect. These brakes are rather difficult to adjust and I do not think I can do better than to give the directions that are found in the Cadillac instruction book. Proceed as follows for the foot brake.—Remove the cotter pin in the adjusting screw "A", and turn the screw "A" until that part of the brake band lining opposite the screw just clears the drum. Adjust the two nuts "B" on the yoke bolt so that the lower part of the brake lining just clears the drum. Then adjust

one end and left hand threads on the other, so that when the brake is fully applied the center of the pin "M" stands 3 3-16 inches to

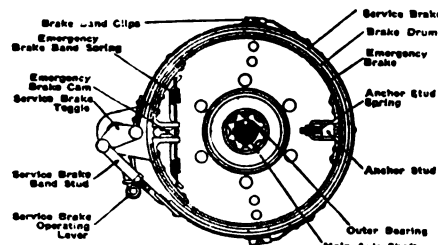

Brake Mechanism of the Chevrolet.

3 1-4 inches away from the inside of the brake drum at "Y". The screws "L" should be turned equally and in the same direction. Release the brakes and adjust the stop screws "R" so that the upper and lower parts of the brake band lining are equal distance from the brake drum. Adjust the stop screw "N" so that the head of the screw just touches the inside of the brake band. Tighten the seven locking screws "K" and replace the cover "F".

MOTOR CARS IN BRITAIN

John Y. Dunlop

Very little is known of the price of next season's cars for the reason that little or no progress has been made in designing and manufacturing these vehicles but it is almost safe to anticipate a substantial increase in comparison with the prices ruling before the war.

Almost every article has increased greatly in price since that eventful August morning and with the labor market at such a high rate and the cost charges still mounting it is difficult to say what will be the result.

Possibly the cost of material will drop to a certain extent when the position of shipping becomes easier and when the restoration of manpower to its normal functions yield a greater production of such materials that do not have to be imported.

These factors, however, will not bring back cars to their pre-war prices for labor will hardly be as cheap and labor accounts for nearly half the price of a British made car.

Doubtless many additional economies in manufacture and processes can be effected and will be under pressure of necessity. Design and finish may be done in such a way as to save substantially without im-

pairing the usefulness or durability of the car.

Before the war it had become the practice to lavish considerable sums on what might be termed the mean trimming of the body of the car and by the adoption of a plainer finish it would be possible to effect some reduction in cost.

On the other hand there is likely to be a demand for refinements that have not yet come into general use such as self starters and electric lighting systems, both somewhat costly yet desirable conveniences.

There has been very little said about the luxury tax in this country recently on cars. Possibly the reason is that so many other things are happening that one cannot dare think that the British government has realized that it is not quite just and fair and economical as was originally thought. But there is no word that this part of the scheme that lists motor cars as luxuries has undergone any change although it cannot have escaped observation that every man qualified to know has given his opinion that in no way can anything else disorganize and lead to unemployment as a state tax on cars on this line. And just at a time when the various types of army or state motor car must flood the country and for which such an expansive organization is being prepared.

They say that the cost of the undertaking will be saved over and over again in the long run, very likely it will for some people, but what about the labor and idle time this will create for some firms?

Now, however, with larger petrol allowances the business motorists will be able to resume their usual trips. I understand that these people will be the first in this country to receive a larger supply of petrol, and as soon as peace is signed it is anticipated that petrol allowances will be granted for ordinary motoring. The extent to which allowances will be increased will depend greatly upon the requirements for military motor transport following the signing of the armistice. The Automobile Association has received assurance that the present restrictions on petrol consumption will be removed as rapidly as possible. Meantime these business cars are restricted to travel within a radius of ten miles, which is a great disadvantage in many cases.

To me, the notion of placing any restriction at all on these cars which mean so much to the markets of the

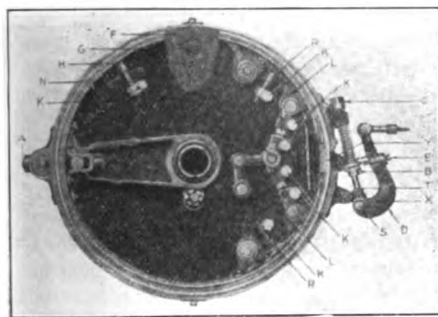

Interior View of Cadillac Brake Drum.

the nut "C" on the upper end of the yoke bolt so that the lever "D" is brought into the position shown in the cut, when the brake is fully applied—i. e., so that the lower edge of the pin "T" and the upper edge of the pin "S" are tangent to an imaginary horizontal line shown at "X". For the hand brakes proceed as follows,—Place a jack under the rear axle housing and raise the axle so that the wheel can be turned by hand. Remove the cover "F", this may be done by loosening the lock nut "G" and turning the bolt to the left about one quarter turn, which releases the clamping bar "H". Rotate the wheel until the opening gives access to the screw "J". Turn the screw "J" until that part of the brake band lining opposite the screw just clears the drum. Rotate the wheel and through the opening loosen the seven locking screws "K". Then turn the two adjusting screws "L" which have right hand threads on

district is out of the question even in present times. In fact, now that we have been able to make good with the world that any restrictions on the production or use of cars, on the taxation of fuel that enables them to run, or on the people concerned with their building, is gross ignorance. But we have it on every hand, at home and abroad, and I am sorry to say that the policies of our allies are much the same.

Peace, however, has her victories no less than war, and the news that at last the people responsible for making motor tires have arrived at more or less of an agreement to limit the number of sizes as a much needed step in the right direction. The plan which has been adopted by the Tire Manufacturers' Association shows some drastic changes.

| | Present number. | Proposed. |
|------------------|-----------------|-----------|
| Bicycle | 33 | 10 |
| Motorcycle | 22 | 6 |
| Light cars | 8 | 4 |
| Motor cars | 62 | 10 |

The idea is to provide tires of the over all diameter which current vehicle types demand and where two or more very similar diameters are used to get makers to eliminate the least used and for that particular type use only the one diameter wheel. To provide only those sections suitable for loads only in the respective diameters. To provide the widest range of interchangeability of tire sections to rims. To reduce the total number of rim sizes and tires in use, and to generally simplify that matter of size, marking and interchangeability. In the light car section four tires are advocated in place of eight, the new sizes ranging from 26x3 to 29x4.

It will be seen that the American car sizes have been adopted, and this will prove, it is hoped, the first step of a scheme of international standardization. The motor car sizes have been more severely reduced in number than any other, seeing that it is proposed to retain only ten types (five normal and five oversize) instead of the 62 now listed. These ten types represent 67-65% of total sales, leaving 33-35% to be divided among the remaining 52 existing types. With regard to the wire type of pneumatic tires, the American range of standard is proposed, since these tires are not manufactured on any scale in this country. This again may eventually help the adoption of a similar range of international standards for this type.

In the inch sizes we are going to adopt the American standard range

of 32, 36 and 40 inch over all tire diameters. The first ranges in sections from three to four inch, the 36 from four to ten inches, and the 40 from five to 14 inches. In this way it is hoped to do away with a great deal of the waste caused by the production of nearly similar types of tires and it is hoped that makers who agree to concentrate on a smaller number of types will be able to reduce their manufacturing costs and benefit not only themselves but their customers.

Another point on which our builders are keeping their eye at the present time is the outer finish. The greater strain to which the surface of the car is subject, the tremendous vibration, the abrasion of flying grit and the expansion and contraction of the metal body when being taken from the warm garage into the frosty air, have all to be considered when studying the best methods and materials for motor car painting. Of course with great care we all know how much the car dealers can keep the surface in good condition, but it is unreasonable to tell an owner that if he uses his car on a muddy road that he must not allow the mud to dry on it. Ordinary mud will not mark high class motor enamel if it is properly removed, and there is no great objection to its becoming dry. If the car is badly splattered with mud it may be to its advantage to turn a hose on it at once and wash the mud off in that way before it dries. However, where the mud has a large amount of tar in it, the mud should, if possible, be removed before it dries, because tar contains more or less solvent oil and

may damage any surface other than glass or porcelain.

In Britain the opinion of the trade is that high class motor enamel is the most serviceable form of car protection for panels, body work in general and fenders. The fact that it does not show signs of deterioration in the way of scratches or roughness, does not crack, and that it can be successfully applied by the amateur painter with first class results, makes it an ideal owner-driver's finish. The difficulty with cheap cars is that as a rule the manufacturers care little or nothing about the durability of the finish providing it has an attractive appearance long enough to sell the car.

The usual finish on a cheap car in Britain rapidly deteriorates, and it is quite a common plan for the owner immediately he receives the car to rub the body down and treat it with a high class enamel, commencing with stopping enamel and following with a coat of matte enamel and finishing off with gloss enamel. It then has an attractive appearance and finish that will retain its lustre and can be easily cleaned.

SIZING A THREADED HOLE

It sometimes becomes necessary to transfer the size of a threaded hole from some out-of-the-way place to the shop in order to make a piece to fit it. With proper tools this is easy; without them, it might be difficult. One thing is always at hand and that is wood. Whittle a stick tapering until it starts in the hole. Then turn it into the hole and a fair thread will be made on the wood. The stick can be carried in the pocket without risk of changing the size, as would be the case with ordinary calipers.

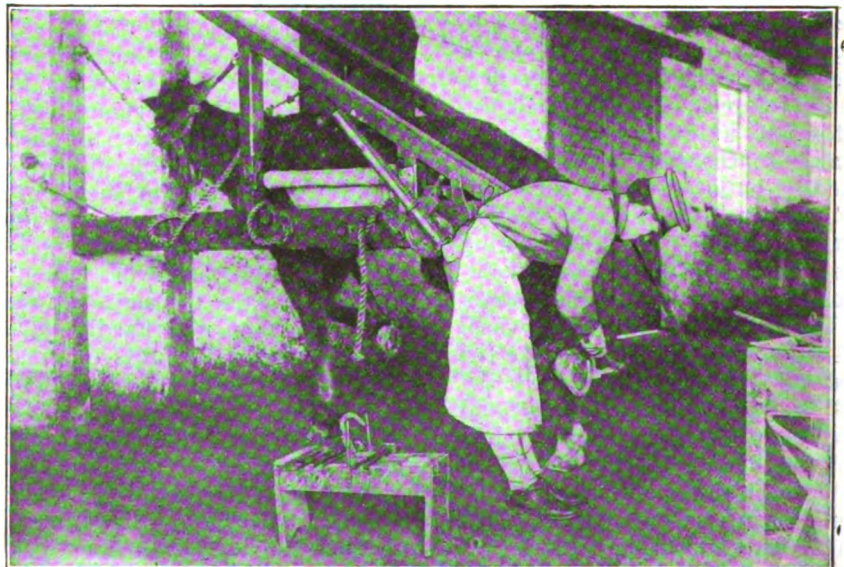

Plate XVII.—Horse in Stocks.

THE ARMY HORSESHOER

Strap the cuff around the postern, the ring above the heels. Pass an end of the rope through the ring and hand both ends over the horse's back to a helper.

To Raise a Hind Foot

Strap the cuff around the pastern, the ring above the heels. Draw the horse's tail to one side and make a loop in it; fasten one end of the rope in the loop by a "single sheet bend." Pass the other end through the D ring and draw it to the rear, where it is held by helpers. The horse is tied, but the head is held as usual. When the shoer raises the foot, the helpers draw in the slack of the rope and the foot is supported (by the himself) in a good position for work. If he kicks he can do no harm, as his foot must move along the rope. After one or two such efforts he will ordinarily stand quiet.

If helpers are not available, the end of the rope may be secured to a post or tree, but must be fastened in a manner to permit a prompt release in case of a protracted struggle, during which the horse might throw himself and be injured.

Mr. Churchhill, instructor in shoeing, used this device for 14

years in civilian practice with un-failing success.

When it is found that a horse is so vicious that it is dangerous to shoe him unless he is rendered helpless, two courses are open. One is to put him in the stocks; the other is to throw him and tie him down.

The latter method is a last resort, to be used only when quieter methods have been tried and proved unsatisfactory.

The harness used in the farriers branch of this school to throw horses for minor operations has been found to

answer the purpose and does not harm the horse. Throwing and "hog tying" a horse without other appliances than a rope should be avoided, as this method usually burns the horse badly and has been known to result in permanent injury.

The throwing harness (Pl. XV-III) consists of:

1. Bellyband with snap hooks for front hobbles.
2. Breast strap with suspending neck strap.
3. Saddle pad with crossed ropes, each 20 feet long.
- 4 and 4. Front hobbles.
- 6 and 7. Hind hobbles.
8. Check strap, used to connect the saddle pad with halter crown strap.

The harness is shown in detail in the illustration. The scale of inches will enable any good saddler to manufacture it accurately, and Plate XIX also shows clearly the manner in which it should be adjusted and used.

WHY A MAGNETO?

J. L. Haky

I have known a number of people who were the owners of automobiles of various kinds that were not equipped with magnetos, and apparently their greatest ambition in life was the attachment of a magneto to a car that was already giving perfect ignition results.

It is not the purpose of this article to malign the magneto nor to recommend without reservation any other ignition system but it is rather intended to discuss the

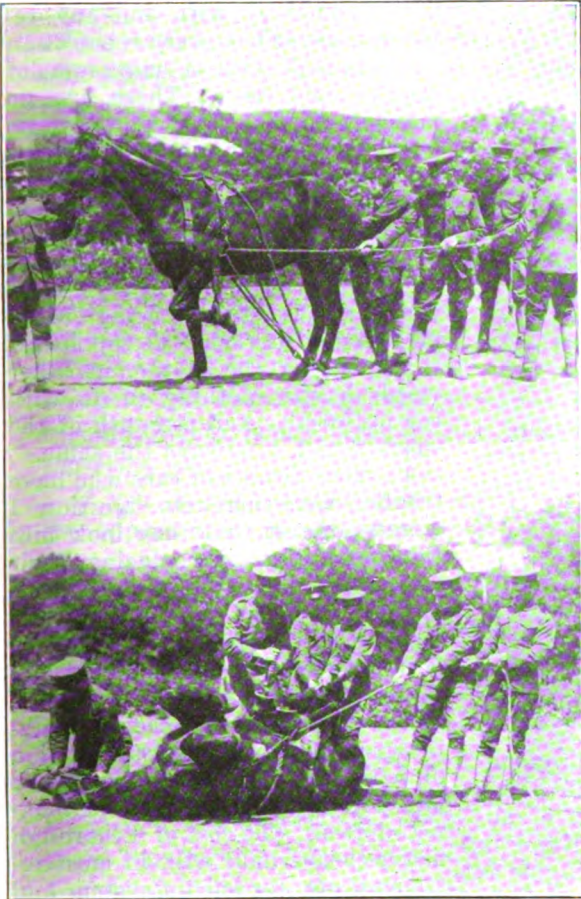

Plate XIX.—Throwing the horse for shoeing.

The horse's head, as usual, should be held by the man that grooms and trains the animal.

This man should stand on the side of the foot to be raised in order to avoid injury if the horse strikes.

The shoer gently but forcibly flexes the knee and raises the foot, while the helper takes in the slack of the doubled rope. If the horse is fractious, the helper passes both ends through the ring on his side. Grasping the rope close under the surcingle ring with the hand nearest the horse's head, and holding the ends securely against the hip in the other hand, the helper is secure against injury, can move with the horse and control the slack to the best advantage.

If a helper is not available, the shoer secures one end of the rope to the D ring (by the eye or by a knot), passes the other end through the surcingle ring on his own side and, after raising the foot, ties a half hitch.

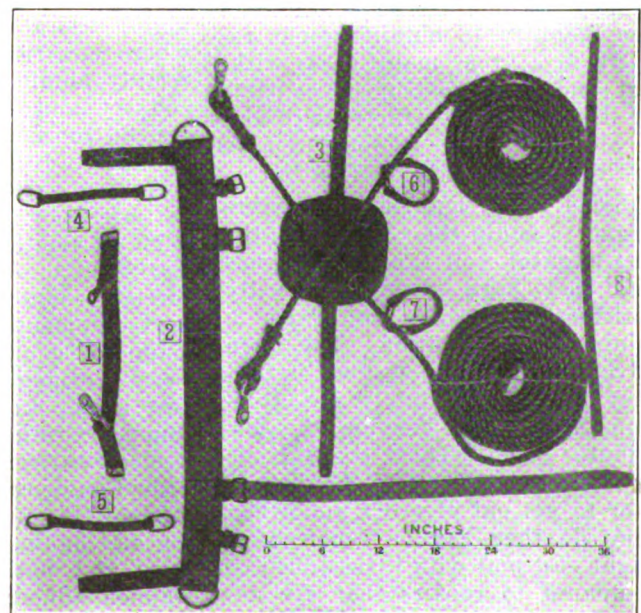

Plate XVII.—Harness for horse throwing.

question of whether a magneto is, after all, something to be greatly desired by those whose cars are not thus equipped.

The early development of the automobile included ponderous induction coils and other equally queer and impressive devices for the production of the life giving spark. Then, with the continued development of the automobile various improvements over the earlier ignition systems began to make their appearance.

Today, on all but Fords and the older models of other makes, there are two systems in almost universal applications—those equipped with magnetos and those equipped with the non-vibrating coil system. The popularity and merit of the two systems under present conditions is about 50-50.

With the introduction of electric starters and the perfection of an "impulse starter" that causes the magneto armature to revolve at high speed until the engine takes fire, many of the early objections and disadvantages of the earlier magneto systems have been automatically eliminated. In most cases it was impossible to get a spark from the magneto by cranking the car and thus an auxiliary battery system was required to get the engine started and then the ignition was switched off on the "Mag." The electric starter has, however, removed this objection in most cases.

A magneto is rather a complicated piece of mechanism with a number of moving and revolving parts and hence is prone to a number of ailments which are aggravated by the inability to obtain proper repairs in a great many cases without sending the instrument or parts of it to the maker for repairs and in all cases where magneto repairs are required it is best to do this.

Some time ago manufacturers began to equip their cars with the non-vibrator coil ignition systems and they have given universally satisfactory results and with a minimum of attention. The main advantage of these systems is that they require absolutely no attention, aside from keeping the distributor clean. There are but one or two moving parts in the distributor to get out of order and when they do they can be replaced at slight cost and with little difficulty compared to repairs that are demanded by magneto troubles.

The coil draws its current from the storage battery and as the storage battery is constantly charged or receiving current from the generator there is little likelihood or trouble with such systems and the results have generally demonstrated their merit. The fact that they are replacing magnetos in a great many instances is sufficient evidence of their reliability and freedom from mechanical troubles.

Why are magnetos being replaced by these systems? For the reason mentioned that satisfactory repairs can be obtained in so few instances at places other than the factory and as the magneto is a rather expensive piece of mechanism the charges are proportioned accordingly.

There is a class of Ford owners who feel that they are missing a lot of the pleasures of life unless they can hitch a magneto to their car. Just why this should be it is not easy to understand—the Ford magneto apparently answers all demands to which it is put in a satisfactory and able manner and that it does is evidenced by the thousands of cars that are in operation with this system. To install a magneto on a Ford at the present time will represent an outlay of approximately \$75 which includes the labor of installation. A number of additional parts are required and in fact the front end of the engine is totally changed in appearance and I do not believe that anyone ever received sufficient benefit from the installation of a magneto on a Ford to justify the expense.

There is, however, one set of conditions where a magneto is highly desirable and that is in cases where electrical service is not so readily obtainable as it is in this country and where one must not depend too much on batteries. For instance, we might cite the difficulties of a car owner in obtaining batteries, or battery service in parts of South and Central America, Africa, Australia and other foreign countries. Hence all export shipments of automobiles are magneto equipped for in such cases the magneto is the lesser of two evils. In America, however, things are rather different for there is electrical service of all kinds to be had on demand.

There is much to be said both for and against both ignition systems and both kinds have their staunch adherents but for simplicity and lack of attention required

I am one of those who believe in the non-vibrator system for the reasons that I have already enumerated and for the additional reason that such systems are foolproof in every sense of the word—there is nothing for some amateur mechanic to monkey with and any replacements or necessary repairs can be obtained with a minimum of trouble and cost. There are no magnets to lose their potency, no bearings to wear out or stick nor armatures to fly to pieces or develop the numerous other ailments to which they are heir to. With the coil you get a hot spark at all engine speeds irregardless of whether the engine is being cranked by hand or racing at top speed, the speed of the motor, in other words having nothing to do with the uniformity and strength of the spark which is always the same.

To those owners of cars who have trouble with magneto ignition I would suggest that they look into the possibility of replacing their magneto with one of the non-vibrating coil systems that are on the market and which are made for both electrically equipped cars and those not electrically equipped. These units fit on where the magneto comes off without the addition of parts or other mechanical work and take up the job where the magneto left off. The cost of a thorough magneto overhaul will, in most instances, pay for such a system and once it is installed ignition troubles practically cease.

HANDY FLUX

Melt a quantity of borax in a small crucible. As soon as it has the appearance of a dark syrup run it out on a dry, clean floor to cool. When cool, powder and mix with filings or fine borings or wrought iron or steel; also add a small portion of carbonate of iron.

When using this compound put it on the work when well red—in fact the steel should be just on the verge of a good fuse when it is applied.

A simple and effective way of determining when the cooling water has reached the boiling point is to drill a 1-32-in. hole in the radiator cap. As soon as the water starts to boil a small jet of steam will issue from the hole. The quantity is not sufficient to fog the windshield or be otherwise objectionable yet it is readily seen and is a sur indication.

The Writing on the Wall as it is Seen by Various Interested Parties

Are you one of the progressive, double action, self-repeating blacksmiths, improving your present opportunities by adapting yourself to the ever increasing automobile and tractor repair business, or are you one of the "old time" blacksmiths who is willing to go plodding along in the same old way; pounding iron and raining sweat, shoeing an occasional horse and taking the chance along with the job of getting kicked over into the next county and returning to your family borne in unconscious state on a shutter?

If you do not take advantage of the opportunities presented to you in this ever increasing business and adding "Automobile and Tractor Repairing" to your sign you are missing the greatest chance you have ever had to make money and make it quicker and easier than you ever could in the blacksmith trade.

Understand that you are just as good a business man, or better, than the regular "garage man." Understand that you are known and respected in your community and that you can compete with the garage man on equally favorable terms for you can get exactly the same prices on all automobile lines through your jobber that you buy your blacksmithing supplies from and which will enable you to sell automobile supplies and accessories for the same good profit to your customers that the auto dealer or the garage man does. You should receive the same consideration that the "garage man" across the street and if you do not—well, just figure out who is responsible. Why let the man across the street who has a sign that says "garage" take this trade and its good profits away from you?

So generally have the blacksmiths in all parts of the country come to the conclusion that they are passing up a good thing by not getting in on this business that consideration of the subject assumes considerable importance at the blacksmiths' conventions.

The Secretary of the Oklahoma

organization has the following to say:—

"At our annual meeting last fall it was one of the very important questions before the membership, and I am sure that we all realize that if we are to hold our own in this particular work that *we will have to prepare to do any and all kinds of automobile work.*"

If there is any further evidence that you want to prove that the automobile repairing blacksmith is recognized and has "official standing" so to speak, we *can* prove it.

Not long ago letters were written to the leading iron and heavy hardware dealers and blacksmiths' jobbers throughout the country and the things that they told us about the blacksmiths getting into the automobile and tractor repair business was a surprise even to us who have come to understand pretty thoroughly the conditions that exist in the blacksmith trade.

A big concern of this sort in Detroit has this to say and it reflects exactly the conditions that exist:—

"The horse shoeing business has come to a point now where it cannot possibly support the number of men in this business and they are therefore, taking up the repair business which they are in many ways more qualified to do than the garage man.

"A good blacksmith is a mechanic by instinct and is an expert in making the small parts that are oftentimes necessary. Further than that the blacksmith business is a much more stable one than the garage business and we find a smaller percentage of dishonest parties in this line than we do in the newer garage business."

Evidently this concern has a pretty good opinion of the blacksmith. Now then after you have taken time to reflect pass on to this paragraph taken from the letter of an old established Minneapolis firm who say:—

"We believe that unless the heavy hardware jobber adds auto accessories, etc., to his stock he will either have to do a very much smaller business or go out entirely."

The firm just quoted has spent 57 years meeting the demands of the blacksmiths and what they say in regard to their own business is just as true of your own—you will either have to do a much smaller business or get out of it.

Another big concern in Saint Louis gives some illuminating information:—

"We are selling quite a share of auto supplies, garage tools and equipment to our blacksmith customers. Some of them are still doing blacksmith work and others have gone out of this line entirely."

The ones mentioned as having gone out of this line entirely have evidently discovered that it didn't pay them to be blacksmiths even as a "side line."

Listen to this one from Indiana:—

"We have found a great many of our blacksmith customers have gone into the garage trade and look to us as a natural source of supply."

Nor does this condition exist only among the blacksmiths of the United States for in a letter from one of the largest jobbers in Canada, located in Winnipeg, they say:—

"We may state that we have been in the accessory business these past two seasons, and that a good percentage of our blacksmiths are now in the garage and body-building business, *especially the more progressive men.* Our business in the accessories and garage equipments from these accounts are very satisfactory.

"The blacksmiths seem to specialize in converting passenger cars into delivery trucks, in lengthening the chassis and building a body for same, while others have become Ford repair shops."

It is a mighty significant fact that these big concerns mention in their letters that they carry *complete* stocks of automobile supplies and accessories. It is hardly possible that a firm that has been in business for over half a century and having a credit rating of over a million dollars would stock up with a complete line of automobile accessories and buy them in carload lots when their business is done almost entirely among blacksmiths, unless they expected to sell those accessories to blacksmiths.

These concerns are the ones that you have been doing business with for years and they have been compelled to take up this branch of business to keep from becoming bankrupt or going out of business just as you will have to do.

Practically every one issues a special catalogue of automobile supplies and accessories with prices that place you in a position where you are able to obtain automobile goods at the same price the automobile supply stores and garages are able to get them and in selling them to your customers realize the big profits that others are reaping from this business.

CONTRACTS OF MINORS

Ralph H. Butz

An infant is any person who has not attained the age of twenty-one years (women in some states eighteen years). Such persons are presumed to be immature, and not capable of looking after their own interests. Therefore the law provides that if they make a bad bargain they may break it. If they buy a horse or a house, they may later return it, and demand the money paid. Further than that, if they have squandered the "consideration" received—as money paid them for something sold—they may still disaffirm the contract, offering to give up any part of the consideration that is still in their possession, and recover what they have parted with.

The reason for this rule is that the privilege of disaffirming is given to the infant for his protection, and it would not be a protection against his improvidence and immaturity of judgment if he were always required to return all that he had received before he could disaffirm the contract. If he has the consideration, or any part of it, in his possession, he must, however, return it to the other party. He is not allowed to disaffirm the part of the contract which requires him to pay, and to affirm the part which requires the other party to the contract to pay.

As to the time of disaffirmance, the rule is that he has until he is of age, and a reasonable time thereafter. If the contract is for the sale of land, he cannot disaffirm until he is of age; but if it is a contract for the sale of personal property, he is allowed to disaffirm while still an infant. As to what is a "reasonable time", the court or the jury must decide in each individual case. There seems to be no limit to the time, except the Statute of Limitations in each state. If at any time after becoming of age he affirms the contract, it then becomes binding, and he cannot afterwards disaffirm it.

It is to be noted that the rule applies only to contracts made by an infant in his own right; that is, when he is selling property he himself owns, or spending money which belongs to him. Infants are legally under the care of guardians, either their parents or some person appointed by the court, and so have little occasion to make contracts regarding their own property.

Infants are bound to pay for

necessaries, such as food and clothing. The burden of proof is upon the seller to prove that the articles furnished were necessaries. And the infant is still protected, for while he must pay for the articles, he is required to pay only a fair price for them. If the seller has taken advantage of the infant and charged him too high a price, he cannot hold the infant for more than the reasonable value of the articles.

Most of the infants transacting business are agents for adults. An infant may be an agent, and so far as third parties are concerned, may make a binding contract. His own contract of agency with his principal is voidable; but while he acts by authority of his principal, neither the principal nor the infant can avoid the agent's contracts with third parties on the ground of the infancy of the agent; and of course the third party could not do so.

A striking illustration of the disability of infants to contract is furnished in the case of *Cresinger v. Welch*. In this instance *Cresinger* was in possession of and thought he was the owner of the property which he occupied, having purchased it from one *Smith*, and having in his possession a Warranty Deed as his evidence of title. There was nothing in the record to show that his title to the property was not good and complete.

Several years after he had purchased the property a man named *Welch* appeared, claiming that a two-thirds interest in the property belonging to him. *Welch* showed a deed from *Cyrus Lupton* and *William Lupton* conveying to him all their right and title to the property. The names of *Cyrus* and *William Lupton* also appeared on a deed in the chain of title through which *Cresinger* claimed ownership in the property.

The fact was established that at the time *Cyrus* and *William Lupton* signed the first deed they were minors; and it was claimed that as such their contract was voidable by them after they became of age. The deed to *Welch* was offered as evidence that they had disaffirmed their first contract, and the claim was set up that the title to their interest in the property was given by the latter deed made after they became of age, and not by the deed made while they were minors.

Cresinger was naturally unwilling

to give up possession of the property, for he had not only paid for it, but had improved it in many ways at a considerable expense. He resisted the suit brought to obtain possession, and the case went to the Supreme Court of Ohio. That court held that the contract of the minors (infants) was voidable, and that the deed given to *Welch* was evidence that the parties wished to disaffirm it; and that therefore *Welch* had good title to two-thirds interest in the property.

Several considerations operate to make the rule less a means of fraud and a cause of trouble than it might at first seem to be. In general, an infant who represents that he is of age will not be allowed to avoid carrying out a contract on the plea of infancy. He is liable for the fraud he has committed, and cannot use the fact of his infancy as a means of wilfully injuring another person.

As previously stated, in most cases where infants do business they act as agents for adults. So while it might seem at first thought that those who deal with minors would suffer endless annoyance because the infants would disaffirm their contracts, there is practically no trouble at all from this source, because most transactions do not come under the rule of law regarding infants.

(Copyright, 1919 by Ralph H. Butz).

SYSTEM IN REPAIR

A little system in your repair work will save a great deal of time in the end. For instance, when the plugs over the valves and the spark plugs are removed, when the valves are to be ground in, these parts usually are placed on the bench or floor and left until the grinding job is completed, after which they are taken up and cleaned. The proper way is to place the plugs in a can half full of kerosene and allow them to soak during the time the valves are worked on. Then when they are to be cleaned the job is comparatively simple, as the soaking has loosened all the carbon, etc.

Much time is also lost frequently in removing nuts from bolts on the chassis, when the threads are covered with hard mud. Owing to the mud the nut is very hard to remove, as it has to cut away the foreign matter when it is backed off. The threads always should be cleaned first. This can be done with a stiff wire brush, soaked in kerosene. Sometimes an ordinary paint brush which has outlived its usefulness as such can be used, especially when the mud is soft.

The first public garage in New York City was located at No. 213 West Fifty-eighth street. It was called a "stable" for gasoline vehicles.

Queries—Answers—Notes



THIS department is the meeting place where you are free to ask for information, answer questions, discuss shop matters and business conditions and any other notes you feel would be of interest to a fellow mechanic. Make use of this Department as often as desired.

Sells Tires and Accessories—Have been away from your editorial pages for some time but have been busy readjusting myself to present business conditions. It is agony as well as pleasure to read of the wails and cries of horseshoers and blacksmiths concerning their business being all shot to pieces. I think they did not put much of a fortification but stood by and watched their business evaporate. The auto, truck and tractor business is here so everyone should get on and get prepared. That kind of business belongs to the blacksmith and if you don't feel that you can handle the auto get the truck jobs. Build platforms and get from \$25 to \$60 for a job that you would put on a lumber wagon for from \$12 to \$20. Sell auto tires, spark plugs, oils and greases, put in a free air machine and if you have lost your old customers get them back if you have to sell your tires, etc., for 10%. Take in their old tires and allow them 10% for them only remember this, don't buy cheap goods; buy the best on the market. Sell oil and grease and sell your oil in half barrel lots at your list price of 68 less 30%, only you keep the 30% and let them pay the freight. Have the oil company make out the bill at 68 cents per gallon leaving off the 30% then you give your customer the bill.—he will think he has made a killing.

Please don't let the mechanics (garage helpers, not mechanics) get the business. I am located on four corners between two cities of 8,000. I am a mile and a half from one and five miles from the other but that does not interfere with me getting the business. Last year I sold 168 tires, 11 barrels of oil, 500 pounds of Lubriko grease, 118 spark plugs and I will mail to anyone an itemized sheet of the year's business. I have just mentioned these items to let some poor blacksmiths know they are the guys to get the pie. This was my first year in the tire game and the second year for oils and I will be willing to give anyone interested some good suggestions from my own experience in handling these lines.

As far as the horseshoeing business is concerned, I for one am glad it has gone, not that I did not like the work but the backache and swearing have also disappeared.

Ten years ago I came to this place and rented a shop that had been closed for six years. Competition was keen with one shop two miles south, three shops two miles east and six shops to the north. I bought \$26 worth of stock and \$60 worth of tools on contract and borrowed \$50 from the bank. Today I own a new shop fully equipped with power and power

tools, residence, auto, etc. I carry a complete stock of auto tires, tubes, patches, plugs springs, etc., together with an A-1 stock of wood and steel for general repair work—I also own a year's subscription to this paper—some asset.

Bert J. Storey, Michigan.

Colorado Prices—I have the only shop in a town of 1,000 and my nearest competitor is 25 miles away. I get .6 a span for common shoes and \$10.00 for neverslips and bar shoes, wagon axles \$10, new bolster with old irons \$10, and tongue complete \$15, new tongue and old irons and hounds \$8, one new hound \$2.50, two new hounds for hind gear \$6 new spokes and felloes 75 cents, setting 3" tires \$1.50 each, narrow tires \$1.25 each, plow pointing \$1.50 each sharpening 50 to 75 cents and other work in proportion.

Charles, E. Wells, Colorado.

coal if it contained no incombustible material such as ash and slate, is the equivalent of 14,500 BTU's. The average of all well known veins of coal in the U. S. is shown by government test to run near to 12,000 BTU's per pound.

S. S., New York.

Appreciates the "Kinks"—I appreciate the kinks given from time to time. They differ from those given in books because they are practical and to the point.

The auto has interfered somewhat with horsehoeing and carriage repairing. If we change with the times it will be possible to make as much money as we do now with a great deal less hard labor.

J. L. Irwin, Canada.

With Us From the Start—I have been a reader of your paper since the very first copy. Your first came to me as a sample as I was a cub in my father's shop but I managed to rustle the dollar for a year's subscription and although I have been a little slow sometimes I have always managed to keep my name on the list and it has made me many an easy dollar.

Now we have taken up auto repair work and I am finding you ready to help us in this work just as you did from your first with every new question that came up.

H. E. Ross, Michigan.

Testing a Boiler—I have a Reeves steam engine at my shop that is getting rather old and has seen a good many years of service but is still in running order with some repairs before it goes into another threshing season. I want to know how to test the strength of the boiler. Some say that they test them with cold water

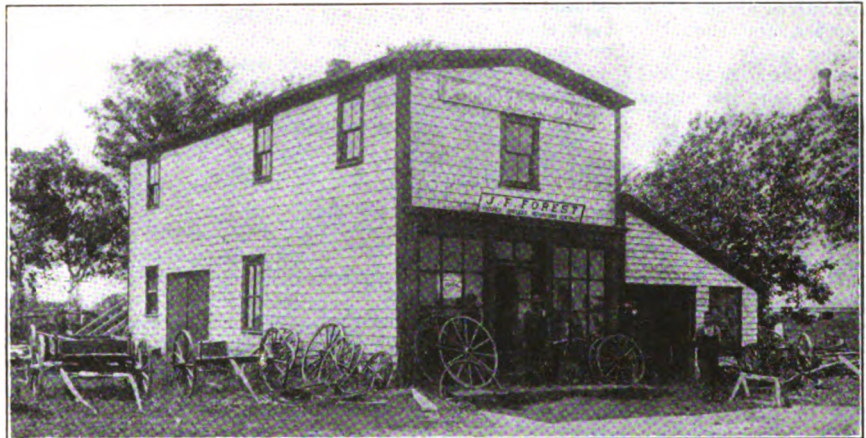

THE WOODWORKING AND GENERAL REPAIR SHOP OF J. F. FOREST IN NEW BRUNSWICK, CANADA. MR. FOREST STARTED IN BUSINESS IN 1907 WITH MERELY A REPAIR SHOP SO THE PRESENT 44x20 BUILDING SHOWS A PERIOD OF SUBSTANTIAL PROSPERITY. HE HAS TWO MEN WORKING FOR HIM AND SAYS THAT HE SHOULD HAVE ONE OR TWO MORE

What is a B. T. U.?—Will you please tell me what the meaning of BTU is? I have seen this abbreviation often and think it has something to do with the heating value of coal but would like to know for sure.

G. S. Hackney, Illinois.

A thermal unit (commonly known as a British Thermal Unit-BTU) is the quantity of heat necessary to raise one pound of water one degree Fahrenheit. In other words, to raise 100 pounds of water 1 degree in temperature will require 100 BTU's of heat. If it is desired to raise 100 pounds of water 12 degrees, then 1,200 BTU'S would be expended. One pound of

and others say with steam. Which would me the best way and how shall I proceed to do either.

C. P. L., Kansas.

Preliminary to a boiler inspection, the boiler, flues, mud drum, ash pit and all connections should be thoroughly cleaned to facilitate a careful examination. Blisters may occur in the best iron or steel, and their presence and also that of thin places is ascertained by going over all parts of the boiler and tapping lightly with a hammer. When blisters are discovered, the plates should be repaired or replaced. Repairing a blister consists in cutting out the blistered space and riveting

AMERICAN BLACKSMITH AUTO & TRACTOR SHOP

VOLUME 18

MARCH, 1919

NUMBER 6

BUFFALO, N. Y., U. S. A.

Established 1901. Published Monthly at the Sidway Building, Buffalo, N. Y., by the

AMERICAN BLACKSMITH COMPANY

Incorporated under New York State Laws.

WILLIAM F. WENDT, *President.*

WALTER O. BERNHARDT, *Editor.*

SUBSCRIPTION PRICE:

For \$1.00 per year, payable in advance, The American Blacksmith, Auto & Tractor Shop will be sent, postage prepaid to any postoffice in the United States. To Canada, \$1.25; to other countries, 6 shillings. Reduced rates to clubs of five or more on application.

Remittances may be made by money order, express order or checks payable to the American Blacksmith Company. We will also accept uncancelled postage stamps or currency, but for safety these should be sent by registered mail.

Subscribers should notify us at once of non-receipt of paper or change of address. In latter case, give both old and new address.

Correspondence on all smithing subjects solicited. Always give name and address, which will be omitted in publishing, if desired. Address all communications to the

"AMERICAN BLACKSMITH COMPANY"
BUFFALO, N. Y.

"Copyright W. F. Wendt Publishing Company, 1919."

Cable Address: "Blacksmith, Buffalo"

"THE MANLESS JOB AND THE JOBLESS MAN."

To owners of shops requiring additional help and discharged soldiers seeking employment:—

If you are one of the above we offer you our assistance in finding help or finding a job and our efforts in this direction will be as free as salvation.

The idea is strictly for the benefit of soldiers and members of the military forces who have received their discharges and are having more or less difficulty in obtaining steady employment.

If you are the owner of a shop and desire to avail yourself of this assistance, write us and give complete information about your location, what kind of a man you want, what you want to pay, etc.,—the information you would want if you were hunting a job.

If you are a mechanic, woodworker, auto repairman, radiator repairman, auto body builder, blacksmith, horseshoer, etc., give us complete information about yourself; your age, salary wanted, where you would be willing to work and other information about yourself an employer would want to know.

We charge nothing nor expect nothing for this service, our only compensation being the knowledge that we have helped solve the problem of the unemployed soldier who is returning to civil life.

RAISING THE DEAD

The national prohibition amendment having been ratified by more than the necessary number of state legislatures, as provided in the constitution, and the amendment having been proclaimed as ratified by the Secretary of State, the prohibition measure thus becomes part and parcel of our national constitution.

The liquor interests in their efforts to nullify the efforts of the majority are loudly proclaiming that referendums will be demanded in 14 or 15 states and that an effort will be made to have the amendment declared unconstitutional.

Instead of accepting their defeat gracefully and submitting to the inevitable

these interests persist in making themselves ridiculous in everybody's eyes—even those in sympathy with them will admit their cause is hopeless.

SOMETHING FOR NOTHING

Is worth what it costs. We are not giving it to you nor are we trying to take it, for 'twould be useless either way and defeat all purposes. But—

If you want a whole lot for a little—we have it in twelve issues of our publication at \$1 per twelve. That's all it costs—this month's number being as good as any for a demonstration.

Send in your dollar and you're one of the 20,000 other "live ones".

CONTENTS—MARCH, 1919

| | |
|--|-----|
| A Bad Roads Article..... | 133 |
| Repairing Aid Drills..... | 135 |
| They Do Things Differently in France..... | 135 |
| Trailer Built of Old Chassis..... | 136 |
| Getting the Car Ready for Spring.. | 137 |
| A Page From Yesterday..... | 138 |
| The First Automobile..... | 139 |
| Motoring in England..... | 139 |
| Cutting Cork..... | 143 |
| Etching Fluid..... | 143 |
| Casehardening Cold Rolled Steell.... | 143 |
| Acid Hardening Bath..... | 143 |
| Hardening Compound..... | 143 |
| Kink Korner..... | 144 |
| Why I Quit Shoeing Horses..... | 146 |
| Electric Welding..... | 147 |
| Ventilating Mine with Blacksmith Bellows..... | 147 |
| Vise Jaw for Tubing..... | 148 |
| Painting Automobiles..... | 149 |
| Unusual Hammer Foundation..... | 150 |
| Avoiding Cylinder Re grinding..... | 151 |
| Stock Accounts..... | 151 |
| Overheating and its Causes..... | 152 |
| Degree of Grades..... | 152 |
| Grinding Glassy Valve Seats..... | 153 |
| Income Tax Problems..... | 154 |

DON'T GIVE MONEY TO AGENTS

The American Blacksmith, Auto & Tractor Shop DOES NOT employ subscription agents. Any person representing himself as such is an imposter and should be so dealt with. Notify us immediately if anyone claiming to represent this journal calls upon you.



If this picture had been printed eight or ten years ago it would have doubtless been considered as the latest thing in dress and—automobiles. There was a time when the possession of an automobile was the distinctive sign of affluence and when no one would dream of starting up his "one lung" engine without being draped in a flowing linen duster and caparisoned with a pair of enormous goggles.

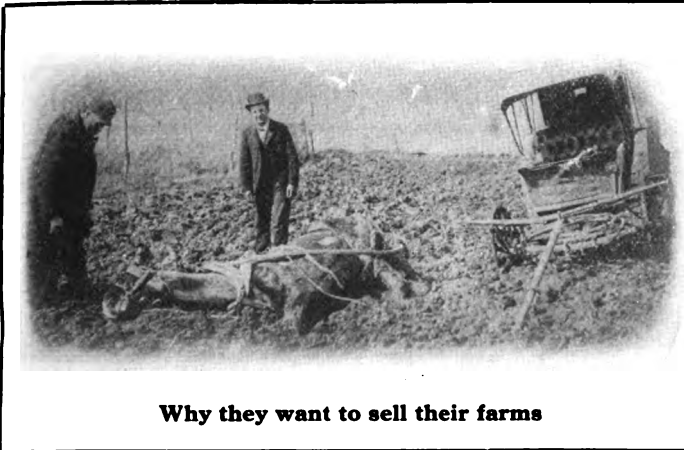

Why they want to sell their farms

A Bad Roads Article

C. E. WYMAN

Roads should be built better and greater interest and care taken in their maintenance if they are to serve the interests of public and taxpayers.

WHO is to blame for the rapid wear of our county roads that cost the taxpayer so much to build

In writing this article I will not name the guilty ones but I wish to make their guilt so plain that the shoes will pinch the right feet and that they will have to wear them until there is a general reformation.

In the first place I will state conditions as they are and later suggest a way to keep the roads in good repair, which is more important than even the first construction, although they should be built better than most of them are. A great many people who use the roads always used poor roads before the present more or less improved roads were built and they count the road good until it is about worn through before repairs are thought of.

To explain why roads wear out rapidly; the first man who drives over it leaves two small tracks, the next will follow carefully in the same tracks and the next and so on for all time, all in the same track until now the motor car and motor truck are, here to stay and help us enjoy ourselves more and get along faster. They too, follow in the same

tracks, mashing and sucking out the loose dirt and pebbles except the sharpest cornered rocks which stay in the ruts and cut the rubber tires every time the tire comes into contact with them.

There is more damage caused to the roads now from autos and motor trucks than steel tires ever



WELL BUILT MACADAM

did, for auto drivers, as a rule, have the same fool tracking habit the horse drivers always had.

Driving in the same track never damaged steel tires but it is the ruination of the roads and rubber tires. The motor vehicle is harder on roads, particularly of the macadamized variety, than horse rigs on account of the greater speed at

which they operate. A sharp rock will be set on the side of the track with the sharpest corner out to nip a piece out of every tire that passes and sharp rocks cannot dodge or bounce out of the bottom of the track and hence they cut holes in the tire and break the fabric, causing the so-called stone bruises and rim cuts even on properly inflated tires.

It is a poor driver that follows a bad example of driving only from force of habit. For pneumatic tires there is more mileage to be gained by driving on the high part of the road, even if it is rough, than in the lowest smooth bottom of the track. There are very few good roads built that are good enough to stand up under even a two ton motor truck operating at from ten to 20 miles an hour when driven in the same track.

Some good roads men say that if we had wider roads that drivers would use more of the road and not drive in the tracks. To show the error of this claim I would refer such persons to bridges on the Dixie Highway over Indian Creek near Greenville, Indiana, in particular, as I am familiar with it. The



AN EXAMPLE OF THE HARM DONE TO A MACADAM ROAD BY AUTOMOBILE TRAFFIC. NOTE THE SUCKING ACTION OF THE WHEELS IN PULLING THE BONDING DUST FROM THE STONE ROAD. THE WIND CARRIES THIS DUST TO THE ROADSIDE AND DEPOSITS IT WHERE IT IS VALUELESS TO THE ROAD ITSELF.

roadway on the bridges is very wide and was at first smooth and level and the road on both sides of the bridge is wide and well made. These bridges have been driven over in the same track to such an extent that the time is not far distant when the floors will be cut through and the bridges are almost new.

To keep our "good roads" and the dirt roads too, for that matter, in repair we should have at least one man for a certain stretch of road every day of the year, except Sunday, whose sole duty would be to fill chuck holes and ruts and allow no water to stand in the roadway. The man should be intelligent enough to understand what he is about and to understand that he is paid for doing it, not a man for seeing what ought to be done and then overseeing the work at additional cost to the taxpayers of the community.

This road maintenance man should be equipped with a light wagon and horse or a light motor truck, the necessary picks, shovels, rock hammers, and a hoe. At intervals the macadamized road surface should be gone over with a scraper or drag. With the outfit mentioned the road maintenance man is equipped to open up clogged ditches, move the earth to where it is needed the most, haul rock and fill ruts and holes. If no crushed rock or gravel is obtainable he is equipped to break up larger rocks and use them for at least temporary repairs as there are usually more or less loose rocks by the roadside that could be utilized.

Under the present semi-political method of building roads and the system of keeping them in repair the wonder is not much that there

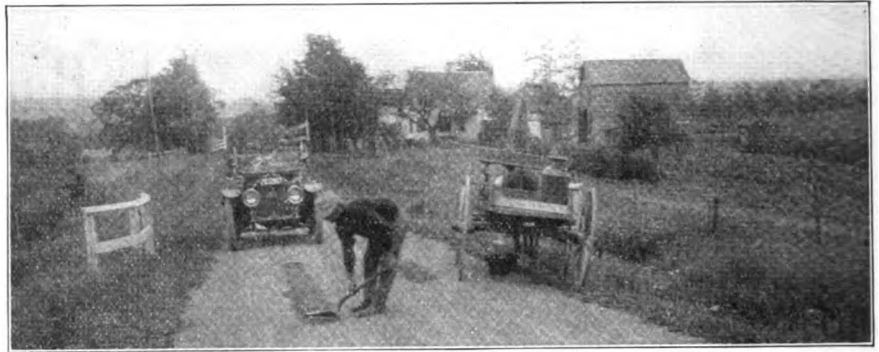

THE TIME TO COMMENCE TO MAINTAIN A ROAD IS THE DAY IT IS FINISHED. ONE MAN, WITH SHOVEL AND TEAM WITH MATERIAL, WILL ADD YEARS TO THE LIFE OF A ROAD.

are bad roads but that they are not a great deal worse. Repairing the roads but once a year is very costly and the roads are so badly worn by the time they receive their annual attention and the promise to do better the next time that all the money thus spent is practically wasted and the repairs thus made are insufficient to keep the roads in permanent condition.

The larger part of our macadamized roads need resurfacing with several inches of new road metal as well as men constantly on the job to see that they are not allowed to run down. While our roads were not primarily intended as competitors to the railroads they are nevertheless competing with them to a great extent and should therefore, be kept in the best possible condition. Every farmer now has his motor car that will take him and his family for a hundred miles almost as quickly and far more pleasantly than by rail and since the motor truck is with us and it is just as though the farmer had a freight station in his barn lot. The truck backs up and

takes on its load of live-stock or produce and is on its way to market with dispatch and with little or no loss from shrinkage.

For the farmer the motor truck is more efficient than railways and saves a great amount of valuable time in the marketing of his produce; but our roads are not built good enough to compete with the railways seriously—they are not permanent enough. Consider the famous Roman military road, the Appian Way, built thousands of years ago and still in excellent condition, as an example of good road building.

For my part, if it is not possible to get anything better than macadam roads, I want them repaired better and better so that the benefits of motor travel may be derived. In writing this article I realize that I have challenged all who have contributed to the present poor condition of our roads and I hope that all will mend their ways and change their methods of driving over roads that have cost so much to build.

PENNSYLVANIA FARMERS OWN 81,505 AUTOMOBILES

The State Department of Agriculture of Pennsylvania has gone to work and done some figuring on the number of automobiles owned by farmers in that state. The report of the Department shows that Keystone state farmers are the owners of 81,505 pneumatic tired cars.

In 1916 there were 30,700 automobiles owned by farmers in the state this number was increased to 58,716 in 1917 and the figures given are for the year of 1918 which, according to the report is 37 percent of the farmers of the state.



NO MATTER HOW FAST THE AUTOMOBILE GOES IT CANNOT EXTRACT THE BONDING DUST FROM A ROAD LIKE THIS, WHICH IS A PROPERLY BUILT ASPHALTIC, OR BITUMINIZED MACADAM HIGHWAY

THEY DO THINGS DIFFERENTLY IN FRANCE, TOO

Conflans, France.

Have been over here for a year but have been mostly in the advanced zone and have had little opportunity to observe French methods of blacksmithing but I know that "marecharliere" means a horseshoer and "forgeron", properly pronounced, means blacksmith. The customer over here holds the horse's foot and the shoer does the work.—I've been wondering how they would make out with a "bronc". All the shoes used here are hand made in the old fashioned way. Two old ones are welded up and pounded to shape in molds. The army shoers have a kind of a neverslip shoe that they use and which come



BRICK ROAD COVERED WITH OILED EARTH.

ready made and have the standard eight holes. I have some of the German version of neverslips. They have one hole in the toe and holes at the heels for calks and are creased and punched with ten holes on a side, running from the point of the toe to right up against the heel calk—they sure made all kinds of allowances for broken feet.

They give all the wheels lots of "dish" in this country—almost pull them double. The felloe and spoke tenons are square and must require lots of exacting work. In the summer when it's dry (that's the only dry time since I've been here) and tires need setting, the French wrap twisted straw around the spokes close to the hub and keep it saturated with water. Every one of their war vehicles that I have seen is fixed up this way. The farmers do it with their wagons too.

I saw a "forgeron" shoeing an ox, using the same kind of a sling that used to be common in the States, but he only put one half of a shoe on the outside of each foot.

The old fashioned bellows is the principal wind producer that I have noticed in custom shops, however, most of the work of the shop is done outside on the sidewalk.

"THEY'RE STILL THERE"

"The most lasting things in the hands of man are the roads which Caesar built and it is true he built a lot of them; and they are there yet."

—Mark Twain.

I have been driving and repairing motor trucks mostly since I have been over here. The war sure was hard on them. The roads were rough and there was so much night work without lights and you may also be sure that work of this sort has turned out a wonderful lot of drivers. As an example of the expert work of the Yanks, our percent of cars in the ditch was less than the French at any place I ever got into but in the morning after a dark night there were lots of all kinds hung up in the ditch.

George N. Bell.

CONVENIENCES FOR THE MAN WHO REPAIRS AIR DRILLS

Repairing Vise For Air Drills:

Figures Nos. 1, 2, and 3 show a special vise or holder for air drills while repairs are being made.

It consists mainly of a round vertical standard or shaft with attached base plate for bolting to the work bench and a double clamping block or head mounted on the standard and carrying a horizontal bearing sleeve and provided with a threaded split collar on the end opposite the shoulder to prevent end play and to give any desired rotary tension. The opposite end of the danrell is fitted with a threaded stud which is to be screwed into the dead handle side of the air drill.

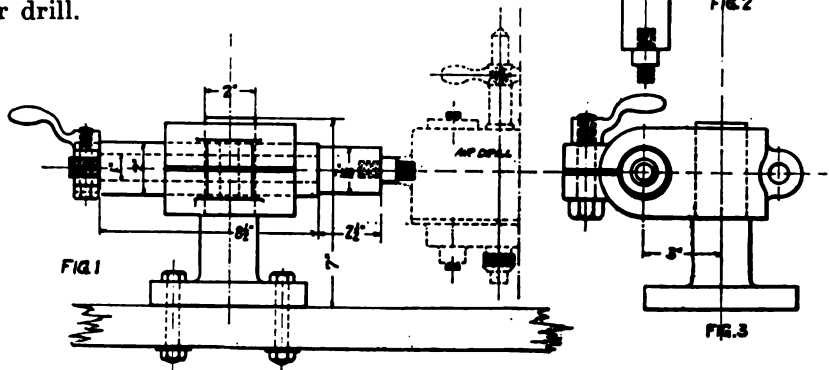

The universal features of the vise with clamping arrangements for all adjustments makes it easy to hold the air drill in any position desired and to make changes from one position to another with the least possible loss of time.

Air Drill Valve Extractor:

The accompanying illustration shows a device for extracting valves from air drills and is made of No. 11 B&S gauge spring steel wire.

When used the bent points or hooks are inserted into the main parts of the valve and a piston or drift plug is inserted from the opposite end until it rests against the

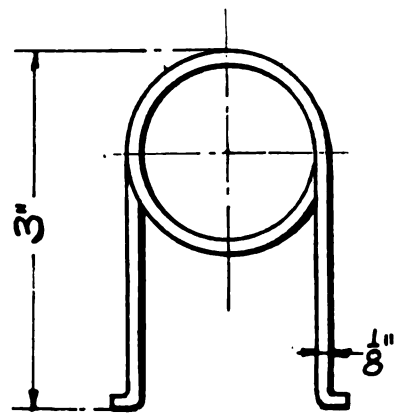

heels of the hooks which acts as driving lugs for the removal of the piston by tapping lightly on the plug.

This obviates damage to valve and block resulting from the usual practice of using a cold chisel against the valve for its removal.

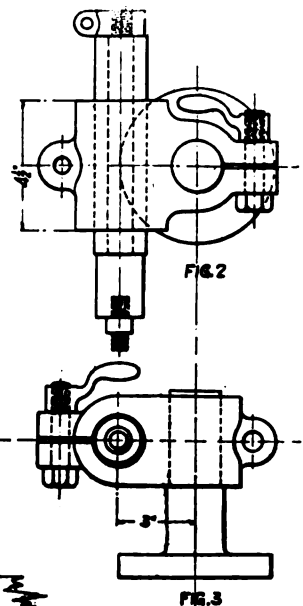

Trailer Built of Old Chassis

C. C. SPREEN

Around almost every garage and repair shop is the remains of a one time serviceable car that has seen better days and has been robbed of most of its parts but usually the running gear—the frame, axles and wheels are in fair condition and it is from such cars that serviceable and thoroughly satisfactory trailers can be made with a minimum of trouble and cost.

The first step of the process is to remove everything from the chassis with the exception of the front and rear axles tie rod, steering knuckle, frame and wheels. After removing the propeller shaft housing, cover the opening in the differential housing of the rear axle to exclude

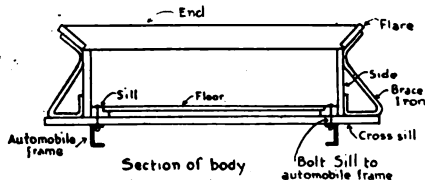

SECTION OF BODY

all dirt and grit that would otherwise enter and prove objectionable.

The construction of the trailer "hitch" and other details are clearly shown in the accompanying illustrations and can easily be made and attached in any shop. In applying a trailer to any automobile and particularly if it of the passenger type some provision should be made for attaching the trailer draw bar to the frame rather than to the rear axle. This should be fitted to both sides of the frame

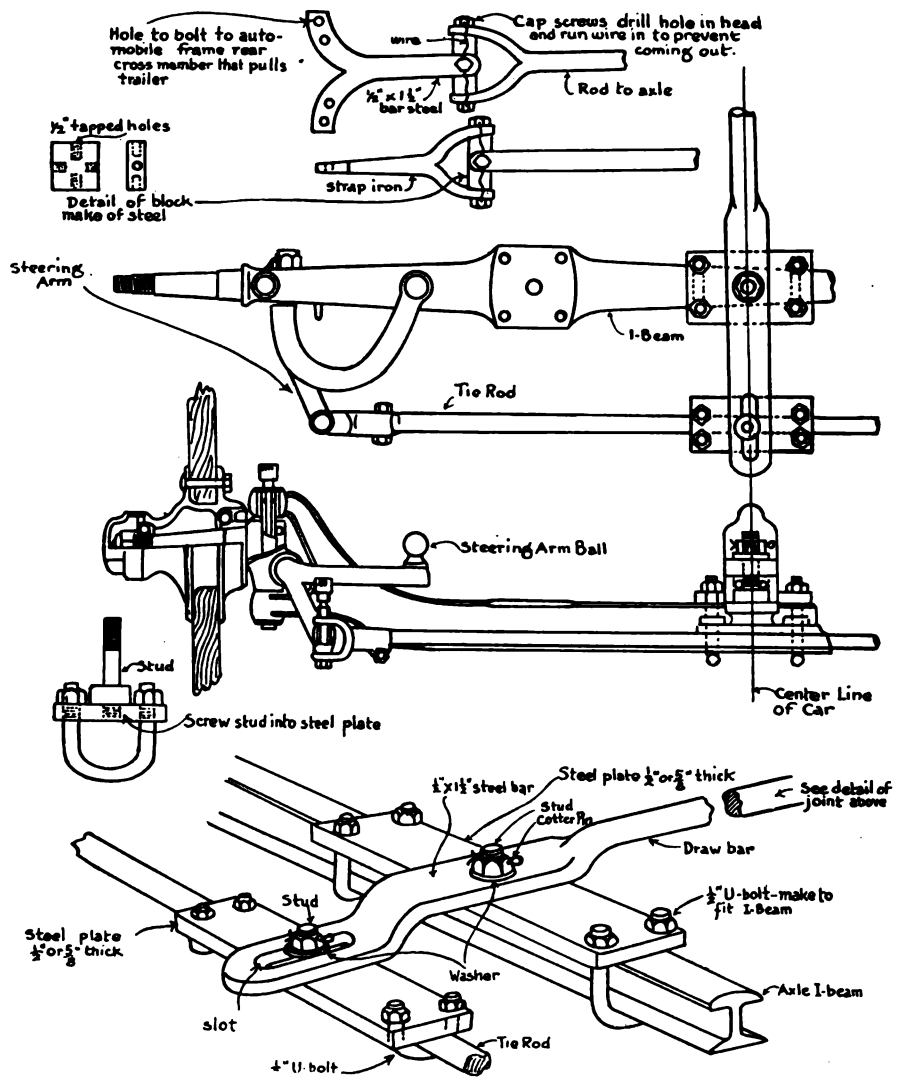

CONSTRUCTIONAL DETAILS OF TRAILER HITCH AND METHOD OF APPLICATION. THIS SAME IDEA WOULD ANSWER ADMIRABLY AS A TOWING BAR BUT THE STEERING GEAR WOULD HAVE TO BE DISCONNECTED BY REMOVING THE DRAG LINK

rather than to one point in the center of the rear of the frame so that the strain will be equally distributed.

VALVES AND CAPS

Among the necessities when touring should be a supply of tire

valves and caps. A slight leak in the valve will cause as much delay as a blowout. A good valve is often hard to obtain when on the road and considerable annoyance can be avoided by carrying these accessories.

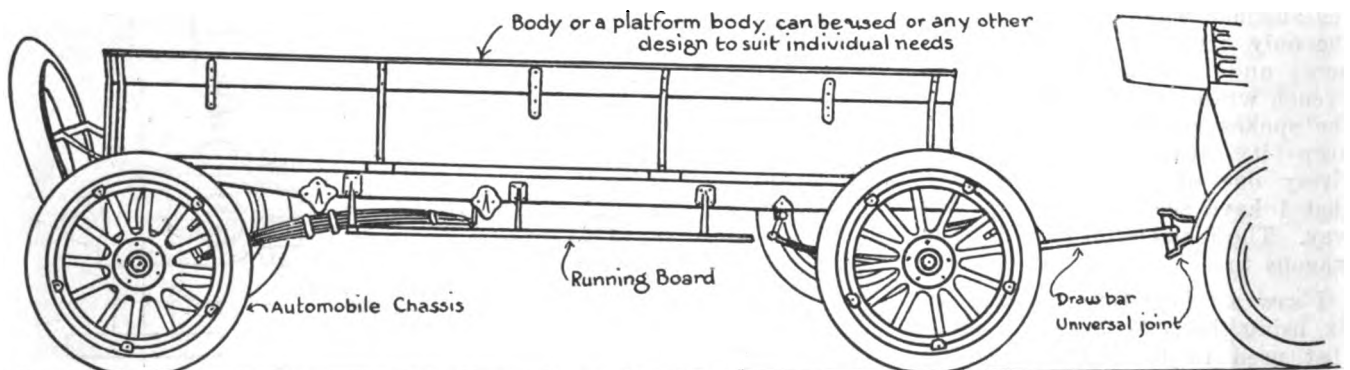

THE COMPLETED PNEUMATIC TIERED TRAILER—AS GOOD OR BETTER THAN ANYTHING YOU COULD BY

Getting the Car Ready for Spring

M. H. GEORGE

THIS is a question that many a car owner who has never had but one car asks himself in the fall after the roads have gotten so that it is no pleasure to drive. Sometimes he will go to his garage man with this question and the answers that he will get are varied indeed. There are honest and dishonest garage men the same as there are in every other business.

The honest ones will tell the car owner just what they think had ought to be done according to their judgment, while the dishonest one will take advantage of the car owners ignorance and tell him that the car is in bad shape and will need quite a lot of work done on it and some new parts.

Now of course it will depend a good deal on the car that you have and the care that you have given it during the summer, about what it will need when it is taken down and how much it will need to be taken down.

At the head of this article I have given the mileage as 5000 but have seen cars go twice and even three times this amount without hardly any work done to them. Then I have seen others with half this mileage that had to have new parts and a good deal of work.

Now a good way to do is to make out a list of the things that you wish to have done to your car and leave it with your garage man and if he is honest he will see that all the things that you have listed are done and looked at and if he finds anything else that needs his attention he will see to that also. Lots of times a garage man will not look into a transmission case or into a differential case as it is not necessary, but of course one cannot tell the condition of the bevel ring or the differential without taking it apart and looking at it. This is the only safe way.

I would suggest a list something like the following to be made out

Fill and turn down all grease and left with the car at the garage cups.

Take off front wheels and grease.

Draw out the oil from the engine and replace with new.

Take oil or grease from transmission and put in new.

Clean out all grease and oil in differential case and put in new.

Look at spring bolts for wear and see that the grease gets to them.

Look at universal joints and put on new leather covering and fill with grease.

Adjust brakes and reline if worn. Look the steering gear over very carefully and oil and replace with new parts where needed.

Clean out carbon from cylinders and grind valves. Take up connecting rods and main bearings. Look at clutch and see that it is all right.

See that the rear wheels are tight on the axles.

If any of the tires have not been off for a long time it will be a good time to take them off and clean the rust from the rims so that the tire will come off easily next season. Look the wiring over.

A lot of these things will not seem to need looking at but this will be a better time to look at them then some time in the summer when you need the car.

Now in regard to the grease cups. —Many people will drive their car in the garage and tell you to fill the grease cups. Invariably you will find them full. I think that most people think that the grease feeds in itself, but this is not the case, when the cups are filled they should be turned down. If they cannot be turned down the bolt or what ever the cup is in should be turned out and the hole opened up. Sometimes if a blow torch is held near the place one can turn the cup down easily. If this small matter is attended to it will stop many squeaks and spring bolts will last longer. If one is going to drive much in muddy weather it is a good plan to turn the cups down until you see the grease come out, this will prevent the mud from getting in and wearing the joints.

The front wheel bearings should be looked at carefully and new ones put in if the old ones are worn. Do not adjust too tight, but so that there will be no lost motion and so that the wheel will revolve easily.

The bolts that hold the steering knuckles may need replacing and new bushings put in. Also the small bolts that hold the tie-rod to the

steering knuckles may need replacing and new bushings. Sometimes all that one needs is the bushings, but if the bolts are worn very badly it is best to get them both as it will take up a lot of the lost motion in the steering gear. The steering gear itself should be adjusted so that it will not have any more lost motion than is necessary, but it steers should not bind anywhere as this makes the car steer very badly. One thing that helps a car that tows badly it to tip the tops of the steering knuckles back. The way to do this is to loosen the spring clips and slip a piece of leather under the spring. The leather should be shaved down thin on one end so that it will tip the knuckle back.

The oil should be taken out of the engine or tank and then clean out with gasoline or kerosene and new oil put back.

If the transmission is taken down the grease or oil can be cleaned off with gasoline. About the only way to get it clean if the transmission is left in the car is to heat the case until the grease will run out and then clean out with gasoline and put new grease in.

The differential should be cleaned out the same way and new oil or grease put in.

The universal joints should be looked at and be sure that the grease gets to them as a good many good universal joints have been neglected as the owner thought that it did not need to be greased very often, when as a matter of fact they do need oil quite often and as they come rather high it is best to protect them with oil or grease as the case maybe. Some are covered with a piece of leather and if this has holes in it it should have a new one as it does not pay to fill them with grease and have it fly all over the car and the road.

The brakes are a thing that is neglected a great deal. It is surprising how many cars a garage man will find, when he goes out to try a car for something, that have the brakes out of commission. Some of them are poorly designed anyway, but that is no excuse for not having them working as good as they ought. The brakes should be relined if they need it or will need it in a short time and then they should be adjusted as good as they can and when the garage man tries out the car for other things he should try the brakes and adjust them again before the owner takes the car.

(Continued on page 141)

A Page from Yesterday

Gen. Miles was much interested in the early development of motor cars and advocated their adoption in the American army.

The youngest person to drive an automobile in Chicago was a fourteen-year-old motor enthusiast in 1900, who applied for and received an automobile license.

A Chicago woman in 1900 took the examination for automobile operator and announced her intention of earning her living by teaching others of her sex to manage the new machines.

A bill was introduced in the Massachusetts legislature early in the year 1900



THE IDENTITY OF THIS MACHINE HAS BEEN LOST BUT PERHAPS IT IS ALL FOR THE BEST. HOWEVER, IT SHOWS AN INTERESTING PERIOD IN THE DEVELOPMENT OF ROAD BUILDING AND AUTOMOBILE CONSTRUCTION

to require all motor vehicles operated in the city of Boston to carry fenders.

In 1900 the commissioners of Baltimore parks decided to admit all kinds of automobiles to the parks, provided the drivers first secured certificates of competence from the general superintendent.

From Cleveland, O., to New York city in thirty-eight and one-half hours was the remarkable record made by a motor car in 1900. This performance eclipsed all previous records in the country. The distance traveled was almost 800 miles.

The idea of numbered license plates for automobiles had birth when the park commissioner of Philadelphia opened Fairmount park to all motor vehicles bearing on their back a black leather tag on which numbers were lettered in white. These tags were supplied by the commissioner.

Automobiles used for advertising purposes first made their appearance in 1900 in France. A motor vehicle on the rear part of which was placed an immense bottle representing some kind of beverage, and another upon which an enormous teakettle was mounted, were the pioneers in this new form of advertising.

The legal regulations covering the operation of automobiles in Switzerland, which were adopted in 1900, read as follows:

"No automobile should be put in ser-

vice without having first been examined by a technical committee, which has to pass on the safety of the vehicle. The operator must also be in possession of a certificate of competence. Each vehicle must be furnished with two lamps, one of which has a white (colorless) glass and the other one a green glass. Finally, each vehicle must carry a plate displaying clearly, and readable at a distance, the name and address of the proprietor."

It is somewhat surprising that the regulations did not touch upon the question of speed.

How to keep warm when automobilizing was simply a question of finance, according to a London concern's advertisement in the winter of 1900, which read: "Wear one of our real calf's leather suits, lined chamois leather, latest French style, £5 5s.; a pair of real cape gauntlet driving gloves, 5s. 6d.; then wrap a warm wool rug around your legs, 10s. 6d.; and have an apron with flaps at sides fitted to your car, protecting the legs from all wind or rain, £1 1s.; after that get a pocket warmer, 7s. 6d.; and also a large foot warmer, 12s. 6d. These precautions will enable you to keep as warm as toast on the coldest day." So they should, seeing that the total cost is only £8 2s., or rather over \$40.—

The city council of Rochester passed an ordinance in January, 1901, which required automobiles operated in that city to carry two lamps to be lighted within an hour after sundown and a gong or bell with which to warn pedestrians.

The Automobile club of Bridgeport, Conn., formed in 1900, started its career by advocating the establishment of an "auto stable" where automobiles could be kept and cared for at a nominal cost.

It was in 1900 that a well-known tailor in Chicago introduced specially designed clothing for motorists. His announcement read in part as follows: "We can furnish a leather chauffeur's suit, packet, trousers, cap and goggles complete an any color found in kid gloves at fifty dollars the outfit."

There was serious talk of granting franchises to run automobiles in Syracuse at the time of their introduction.

In Reading, Pa., an early motorist was arrested for driving his horseless carriage "faster than a common trot."

In the early days a chauffeur was called a conductor.

At the dawn of the automobile industry many enthusiasts predicted an early decline in the value of street railway stock as a result of the advent of the new form of locomotion. That it would soon supersede the street car was their confident expectation.

"In order that the automobile may become the 'all-year-round' vehicle that its general adoption will soon demand, it must be rendered secure from damage from freezing temperature," was the comment of the pioneer automobile critic.

In Paris, at the Cycle Automobile show

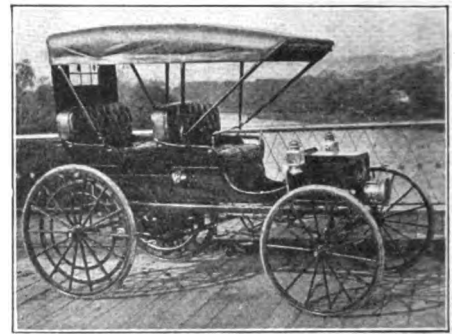

DURYEA SURREY WITH THE 2-CYLINDER, 2-CYCLE, AIR-COOLED ENGINE OF ITS DAY, WHICH SOLD FOR \$700. WITH A CAR LIKE THIS YOU KNEW WHERE YOU WANTED TO GO BUT YOU DIDN'T KNOW WHETHER YOU WOULD GET THERE UNDER YOUR OWN POWER OR A TEAM OF MULES. AH, FOR THE GOOD OLD DAYS OF 7 H. P. ENGINES

in 1901, a large American automobile manufacturing concern was refused permission to exhibit its machine by the police on the ground that it was "dangerous."

An interesting suit was tried in Hackensack, N. J., in 1900, to determine whether or not the automobile was a common nuisance. In a few minutes the jury brought in a verdict in favor of the automobile.

The first private garage constructed in New York City was built in the spring of 1900, by a prominent New York automobile enthusiast, who at that time owned three motor vehicles.

The Chinese looked with disfavor upon the early automobile, fearing that their introduction into the land of tea would displace the porters, who were very numerous, from their jobs.

That even the early horseless carriage retained at least one characteristic of its honorable predecessor, the horse, is evinced by the following item written in 1900: "The claim advanced by the early pioneers that an automobile could not run away like a horse, is being disproved by actual experience. Accounts of automobile run-aways are not infrequent in the daily press."

In 1899, New York automobile laws allowed automobiles to travel not more than four miles around street corners.



THIS IS A 1914 POPE. WE OFTEN WONDER IF THE AUTO MAKERS FEEL THE WAY A MAN DOES WHEN HIS WIFE DRAGS OUT THE FAMILY ALBUM AND SHOWS THE "COMPANY" A PICTURE OF HIMSELF DRESSED IN A VELVET SUIT AND LONG CURLS, AND TAKEN WHEN HE WAS FIVE YEARS OLD

THE FIRST AUTOMOBILE

Elwood Haynes

It was during the delay in the work of constructing the pipe line for the Indiana Gas and Oil Company at Greentown, Indiana, that it occurred to me that some better means of locomotion over the highways, than the horse and buggy might be procured, so I accordingly laid plans for a mechanically constructed vehicle.

In the fall of 1892 I moved to Kokomo, Indiana and the following summer (1893) had my plans sufficiently matured to begin the actual construction of a machine. I ordered a one-horsepower marine upright, two-cycle, gasoline engine which weighed 180 pounds.

When the gasoline and battery connections were installed, the motor, after considerable cranking was started and ran with such speed and vibration that it pulled itself from its attachments. Luckily, however, one of the battery wires was wound about the motor shaft and disconnected the current.

In order to provide against vibration, I was obliged to make the frame of the machine much heavier than I first intended. The "horseless carriage" was built up in the form of a small truck. The framework in which the motor was placed consisted of a double hollow square of steel tubing, joined at the

DURYEA'S ELECTA. A Carriage for the Elect.
 Combines the elegance, comfort, cleanliness, noiselessness and simplicity of the electric with the reliability, long range, light weight, low cost and everreadiness of the gasoline car. Faster, handier, simpler, lighter, more durable and less expensive than an electric.

No tire trouble, no punctures, no delays, no complicated mechanism, no transmission, no differential, no clutch, no propeller shaft, no universal joints, no gears, no chains, no complicated oilers, no dripping oil, no freezing water. Just the cleanest, simplest, handiest and most comfortable auto you have ever seen.

CHAS. E. DURYEA,
 READING, PA.



WHAT MADE THE DARN THING RUN?—Read this ad. and see if you can figure it out. This car was equipped with 2 cylinder, two cycle engine— about the kind they put in motorcycles today—it was air cooled and sold for \$850.

rear corners by steel castings and by malleable castings in front.

At that time no figures were accessible for determining the tractive resistance to rubber tires on ordinary roads. In order to determine this as nearly as possible in advance, a bicycle, bearing a rider, was hitched to the rear of a light buckboard by means of a cord and spring scale. An observer seated on the buckboard recorded as rapidly as possible the "draw-bar" pull registered by the scale.

The total weight of the mach-

ine when completed was about 820 pounds. July 4, 1894, when ready for the test, it was hauled into the country about three miles behind a horse carriage and started on a nearly level turnpike. It moved off at once at a speed of about seven miles per hour and was driven about one and one-half miles into the country. It was then turned about, and ran all the way into the city without making a single stop, and thus America had its first successful motor car.

MOTORING IN ENGLAND

John Y. Dunlop

Among the new conditions and developments of motoring sure to follow the end of the war is the all important question of fuel. Everybody in this country, except possibly the gasoline companies, is agreed that there must be and will be a new fuel source discovered and that such a discovery would be to everyone's benefit.

Already, more than one discovery has been announced. Mr. E. S. Sharpnell Smith, the petroleum executive officer, has made it public that a remarkable step forward has been taken in the development of the suction gas producer. An apparatus of this kind has been in use for some time and which gives results equal to gasoline at five pence (ten cents) per gallon. This first rough apparatus, it appears is being used in a three ton truck and as its weight is not more than 2½ Cwt. it will be seen that with a little



POSSIBLY SOME OF THE "OLDEST INHABITANTS" WILL BE ABLE TO RECALL THE LOGAN CAR—THIS IS IT. IF THE BODY HAD BEEN MADE OF WICKER WORK IT MIGHT ALMOST BE MISTAKEN FOR A TWINS' GO-CART

further refinement that it should prove a perfectly practical means of carrying on an immense amount of commercial work.

Even allowing for a good weight of fuel and water, there should be no inconvenience in managing the comparatively short journeys required by most commercial cars. Further, there should be a big future for it in connection with farm tractors. In both cases the trips are much shorter and weight is of less importance and economy is of greater importance than is the case with passenger cars.

To date there are no indications of anything revolutionary in engine design. One English firm is about to bring out an engine with five cylinders arranged radially about the shaft but otherwise designs will follow 1914 practice more closely than most people think.

It has been freely predicted that aircraft practice would work wonders in the development of motor car engines but those who argue this may possibly have overlooked the fact that the requirements of the two engines are radically different and that the conditions under which they work are also dissimilar. The aero engine is driven at full load practically all the time and is designed with that object in view. It develops a power that could not be used on the roads of any country and it



THEY WENT WILD ABOUT PICTURES OF THIS SORT ABOUT 1900. IMAGINE A LADY OF TODAY DRIVING A CAR WITH NO WINDSHIELD—HER COMPLEXION WOULD BE RUINED!

would be expensive out of proportion to its usefulness.

It appears, from all that can be gathered from the intentions of the makers, that the only new departure from previous practice will be the more general adoption of six cylinder instead of four cylinder engines. There are also rumors in some quarters of an eight cylinder engine but it is to borne in mind that this is no novelty. It may be something of a departure for the British manufacturer but the eight cylinder engine and indeed even twelve cylinder engines have been in use in the United States for several years.

There is one thing, however, that the motorists are heartily glad of and that is the removal of all restrictions on motoring. We are now free to resume motoring at will and for any purpose we choose so far as 50 gallons of gasoline per month will take us or with an increase of 50% in any proportion of fuel which may be taken in the form of benzol.

To what extent we can depend upon the supply of benzol to meet the increased demand for motor fuel and to keep down the price is a question difficult to answer. There has been a greatly increased production of benzol during the war for strictly war purposes but even if this is sustained it will not be available for motorists as most of it will go to certain industries that have always used it in large amounts. It is also hinted that the benzol manufacturers are planning to establish a standard for benzol much inferior in quality than that required for motor fuel. As it is, benzol has the one serious defect of freezing too easily. This fault it is understood, was overcome first by the Germans and then by ourselves by the production of an allied fuel to be known as Benzax. What will be the price of this new fuel or improved benzol is still unknown. Sooner or later a price must be set and then we will be able to weigh the value of this new motor fuel.

Of course the price of everything in the motor world is causing much concern to the heads of motor factories in this country and prices are bound to rule high. An example of this is shown in the Ford car which is to be made in British factories at the cost of 250 pounds sterling. Before the war an Import-

NUMBER OF AUTOMOBILES REGISTERED IN UNITED STATES ON DECEMBER 1, 1918, EXCLUSIVE OF TRUCKS

| | |
|----------------------|---------|
| Alabama | 46,155 |
| Arkansas | 41,458 |
| Arizona | 22,671 |
| California | 288,173 |
| Colorado | 70,000 |
| Connecticut | 84,902 |
| Delaware | 12,066 |
| District of Columbia | 40,046 |
| Florida | 47,059 |
| Georgia | 99,160 |
| Illinois | 389,135 |
| Iowa | 327,500 |
| Indiana | 227,160 |
| Idaho | 31,925 |
| Kansas | 186,109 |
| Kentucky | 65,884 |
| Louisiana | 39,355 |
| Maine | 42,154 |
| Michigan | 261,167 |
| Minnesota | 201,127 |
| Missouri | 185,146 |
| Massachusetts | 176,564 |
| Maryland | 78,146 |
| Montana | 50,125 |
| Mississippi | 40,000 |
| Nebraska | 175,370 |
| New York | 453,588 |
| New Jersey | 129,011 |
| North Carolina | 72,300 |
| North Dakota | 70,531 |
| New Hampshire | 20,458 |
| New Mexico | 16,893 |
| Nevada | 7,987 |
| Ohio | 417,400 |
| Oklahoma | 120,300 |
| Oregon | 66,607 |
| Pennsylvania | 370,110 |
| Rhode Island | 30,595 |
| South Carolina | 55,400 |
| South Dakota | 84,004 |
| Tennessee | 61,500 |
| Texas | 250,083 |
| Utah | 27,204 |
| Virginia | 72,228 |
| Vermont | 20,764 |
| Washington | 119,905 |
| West Virginia | 37,025 |
| Wisconsin | 196,844 |
| Wyoming | 16,150 |

Total...5,945,442

ed American Ford car cost 120 pounds sterling and was fair value at the price. The new departure in price is quite unexplained but there is one thing which can be taken for granted that what the English public wants is cheap cars for general use and so far as the circulation of money is concerned in this country, a dozen cheap cars are of more use than one lordly limousine.

The reason that some men accomplish more than others is that they attempt more.—Personal Efficiency.

Getting the Car Ready for Spring

(Continued from page 137)

The engine should have the carbon, cleaned out and the valves ground in. If it is any advantage to take the cylinders off to do this job it had better be done and then one can get at the bearings a little handier. Then the piston rings can be looked at to see if they are worn. The main bearings should receive the same attention as the connecting arms, for they will cause a worse knock than the arms.

If your car has a pump to circulate the water it should be looked at and see that it is doing its duty. The rubber hose that is used to make the connections between the pump and radiator should be replaced with new as sometimes the inside will get loose and double in and not let the water through freely.

The clutch should be cleaned so that it will work nicely and if it is a leather lined one this will be a good time to reline it. No matter what kind it is it will help it to clean it up.

In my list I have called attention to having the rear wheels tight on the axles. Of course if the wheels are taken off they will be tight when replaced. I have seen a number of cars that have been run with the rear wheels loose and it most always causes damage. Sometimes the spline groove will be broken out and sometimes the spline will shear. Then again the hub may break, and the axle will be spoiled, it all ends in a large bill of expense while a little carefulness would have avoided it.

It is well to give the tires a careful going over so as to start out in good shape in the spring. If the rims are rusty the rust should be cleaned off and the rims painted so that the tire will come off easy if you are twenty or thirty miles from garage.

If your car is in a garage where you can go in and look at it once in awhile one can have a lot of little things attended too that he can't if it is in a large garage where you do not see it until it is done. I know the garage men do not like to have the owner around when they are working on his car, for a good many reasons I suppose. I could give some as I have had an "experience", but will not here. A lot of little things the owner can do himself if he has a mind to do so and has the time. The body

"GO THOU AND DO LIKEWISE"

Read Mr. Bernardi's article in this number about his business and then send us an article about your own ideas of doing business. Mr. Bernardi didn't write it exactly that way but he furnished us with the facts and the idea and that is what we want some of the rest of you to do.

It isn't a question of how you write it, that's a part of the editor's job, to get things into readable shape. But you just furnish us with the facts just as Mr. Bernardi has done and send us a couple of pictures or so. We aren't conducting any "prize contests", we don't find it necessary. Anyhow you won't have to wait until our will is read to learn how your cooperation is appreciated.

bolts can be tightened and stop squeaks. Bolts and screws around the floor boards and wind shield should be tightened and doors wedged so as to stop rattles.

One can take an old rattling car and spend a day's time on it and stop so many squeaks and rattles that the owner would not know it. This is work that most garage men dislike to do. You drive into a garage and tell them you want the carbon taken out of your engine and they will put a man on the job quick, but you tell them that you have a rattle or a squeak that you want stopped and they will all be busy. I do not know why as they charge seventy-five or eighty cents an hour for both jobs, so what is the difference?

Now as I said before that all cars are not the same, even of the same make and care, in regard to the amount of new pieces and work that they will require. But it is a safe plan to look them over in the winter months when you cannot run. If the garage man could tell the condition of a transmission by looking at it as he is sometimes asked to do, it would not be much of a job to overhaul a car, but as he cannot it is best to begin and take down the different parts, such as, engine, transmission, differential, etc.

One cannot always tell after it is taken down as I have seen parts taken out that looked alright, and put back in and would break that day, but it is better than taking a chance.

The winter is the time to put on a new coat of paint as it will have plenty of time to dry and become hard before you need to use it.

Time is money to the man who has brains enough to coin the minutes, hours, and days at his command into cash in the mint of his experience and initiative.

HINTS FOR STEEL WORKERS

To weld a buggy spring, scarf each end, punch a hole half an inch from end; lay a thin piece of iron between; then rivet together and heat to a low red.

Never upset a cold chisel; rather draw it out and cut the end off. The same with stone cutters' tools, etc.

To restore burnt steel, heat to a red; cool in water, and repeat two or three times. It will restore steel to a certain extent.

To weld low steel or iron to malleable castings, use one part sal ammoniac to ten parts borax, melted together, then ground fine. Heat slowly, same as welding steel.

When it is required to harden small spiral springs made of steel wire, or springs for locks, or any of the other kinds of slight springs, they will require to be uniformly heated.

If the iron be heated quickly up to a welding temperature, only a very small part of the iron is heated at all, and the spreading of the heat to other portions of the iron robs the weld of its heat before enough hammering can be done to make the weld solid. Heating slowly gives the heat a chance to penetrate a larger mass of the iron, thereby enabling the weld to hold heat until the softened iron can be properly united by hammering.

Move the iron frequently in the fire. It does not do to let the pieces lie still from the time they are placed in the fire until the work is removed to the anvil. Instead, keep both pieces moving every few seconds, and just before they are quite hot enough, especially if quite small, keep them moving continually. A better weld is made by so doing, as the constant movement of the pieces seems to distribute the heat more evenly than when the irons are allowed to remain still in the fire.

EMERGENCY TIRE

Wrap a piece of one-inch rope several times around the clincher rim, filling it and sticking out above the surface. Then wrap a piece of half-inch rope around the rim crosswise and between each two spokes. This serves very well in an emergency, where no spare tire is available. It does not make luxurious riding and the car must be driven at moderate speed, but it saves the wheel and rim from damage.

THE VILLAGE MERCHANT

"After twenty years in business at the old stand, Ripley Rant is being closed out by the sheriff today to the highest bidder," said the landlord of the Petunia tavern. "You see, Rip's theory of the art of running a grocery store was to out-yell all comers. His other idee was that the customer was always wrong. If he hadn't got what the customer wanted the durn customer ort to want what Rip had, and if he didn't like it he could get out.

"Customers disturbed him a good deal, anyhow, by insisting on being waited on when he wanted to argue with some of his cronies about the burning issues of the day. He knew almost everything about everything, knew it in tones of thunder, and knew the most of it wrong.

"Frinstance, he knew how General Pershing ort to proceed in whipping the Germans, and when he did exactly the opposite and yet whipped 'em to a quivering custard, old Rip was almost as much disgusted with the General as if he had been defeated.

"He preferred convincing a man against his will to selling him a big bill of goods and if the customer was convinced quick enough he could get anything in the store on credit. So the sheriff is closing him out today, and Rip doesn't seem to know how it happened."—Country Gentleman.

You never can tell. Many a man is obliged to pocket his pride without allow- his clothes to get out of shape.

Versatility doesn't always inspire our admiration. Lightening never strikes twice in the same place but we prefer the clock that does.

Evidently from the prices of things the well known horn of plenty was blown long ago.

Kissing may breed all kinds of germs but that is the least of its dangers.

The lady who works in a beauty parlor is quite apt to be well acquainted with all the new wrinkles.

It isn't all of Christianity to go to church. Many a man who is cock-sure of going to heaven is in the wrong pew.

Although a non-essential the proprietor of a Turkish bath should clean up a fortune.

A little thing like insomnia won't keep a woman awake at nights the way a husband who talks in his sleep will.

Do not squawk about your luck. Maybe if you had all that was coming to you you would be in jail.

The leader of the Anti Cigarette league has just announced that: "the war is over, and the cigarette is again a deadly poison."

It is this kind of bunk that makes a sane man mad at any form of prohibition. The cigarette did as much to win the war as any one thing we know of. And if a cigarette wasn't poison to our soldiers it isn't poison to our civilians. And, at that, we do not smoke cigarettes, but we do hate bigotry.

Any man is set in his ways who considers that we are set in ours.

Cast your bread upon the waters. It certainly has a softening influence.

The long and the short of it is that the shortcomings of other people last longest.

The office that seeks the man is evidently dodging the clutches of the suffragettes.

Some people are opposed to certain pleasures on religious grounds because they cost so much.

You can never tell. Many a man leads a fast life because he is fast to his wife's apron strings.

Even when a man brings it on himself ne complains that it's always the unexpected that hapepns.

Procrastination is the thief of time. Insomnia is never ready to say goodbye until the alarm clock is ready to go off.

It isn't polite to tell a whole country to dry up, but that's the way the Prohibitionists have talked to Uncle Sam.

A woman places as much confidence in a pin as a man does in a suspension bridge.

Remember the day when people used to throw eggs at actors?

When men are friends they drink and talk and treat but they don't kiss each other when they meet on the street.

The principal trouble with the easy going fellow is that it's so hard to get him started.

The angel plays a harp but a harpie is quite another bird.

A man can either keep his own counsel or engage a lawyer.

A woman's tears will either cause her husband to give in or shell out.

You never can tell. Some people pay as they go, but never go anywhere.

The sportsman is always ambitious to shoot big game but the piker is satisfied with craps.

You can reach a man's heart through his stomach and then use a stomach pump on him.

When a fellow is in love he never stops to consider that the girl may grow to look just like her mother.

The world's greatest men don't seem to take themselves as seriously as some of our small politicians.

Perhaps the only way to keep ahead of the game is to follow the crowd.

Some people regard an open countenance as a place to throw things in.

Even in the social scale many a man is addicted to the short weight habit.

Of all her features the pretty girl regards her nose as the scenter of attraction.

The worst thing about blessings in disguise is that the disguise is also so perfect.

Some people can even capitalize their sorrow. Perhaps you have heard of profit tears.

The Cynical Bachelor observes that matrimony is the refuge of the fellow who is his own worst enemy.

In admiring feminine beauty the rounder may have a perference for curves, but he can't always square himself.

The paperhanger's apprentice who loses his job because he can't get the hang of it might try working in a rubber factory. He would probably get the bounce there.

When other people don't like us we can always blame it on their bad taste.

Curiosity isn't limited to women. Many a man proposes to a girl just to see what she'll say.

Perhaps the reason why the average man isn't satisfied with his lot is because other people have a lot more.

The ragged edge of despair isn't always indicated by the fringe around the bottom of a man's trousers.

You know that it takes a lot of courage to borrow money from a friend. But maybe you do not know that a friend has to have more courage than that to lend it to you.

When the flat on one side of a man contains a 60 h. p player piano and the flat on the other side contains a 30 h. p. phonograph it is a waste of time to tell him anything about the soothing influence of music.

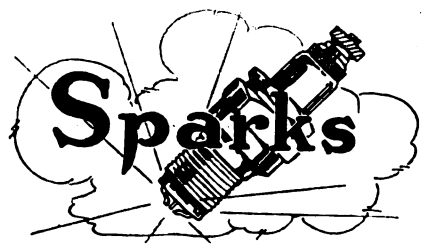

The owl is a wise bird but the crow never does anything without caws.

Perhaps no man is a hero to his valet because no man is valet to his hero.

No, we would hardly recommend the study of botany for flowery speech.

Just because a fellow is there with bells on, don't jump to the conclusion that he's a ringer.

Some people go on the principle that none are so blind as those who refuse to look for trouble.

The court jester is obsolete but there was a time when kings kept their wits with them.

The Lord helps those who help themselves but He doesn't altogether overlook those who help others.

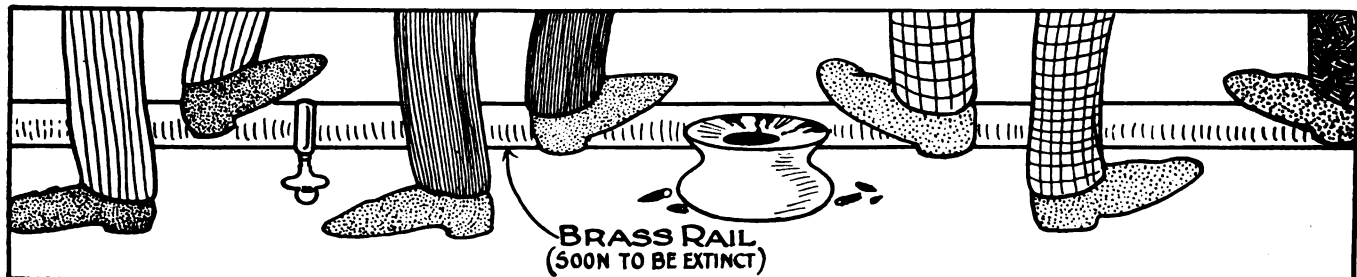

OUR ARTIST'S IDEA OF DRY HUMOR

**"CHEAPER TO RAISE HAUL-
AGE UNITS THAN TO BUY 'EM'"**

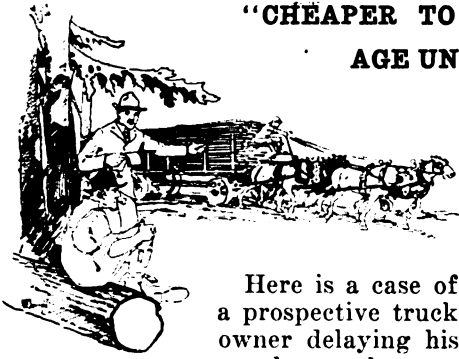

Here is a case of a prospective truck owner delaying his purchase because he raised his own horses, feed and labor, in consequence of which he figured that, outside of a few miscellaneous items, his haulage cost him nothing. Here is the story:

A man for a truck representative in Northwestern Oregon recently ran up against a hard proposition in an attempt to sell motor truck equipment to a man living out of Oakland, Oregon, where conditions for a truck were ideal. This prospect had a big wood contract with a hotel. The round trip haul was about 40 miles.

The salesman knew his business and was prepared to show the man that one truck would replace the four four-horse teams he was then using. The man with the wood contract, however, refused to buy trucks, asserting the equipment would cost too much.

The salesman explained that the price of the one truck should not be compared with one four-horse team, but with the four teams, harness and wagons that they would replace. Considered on this basis the investment was about the same. The woodsman couldn't

see the point and squelched the argument by retorting that the horses didn't cost him anything anyway, because he had raised them himself.

The truck man politely allowed the matter to rest and introduced the relative cost of feeding the sixteen head of horses as compared with the expense of fuel consumed by the one truck. But the old man wouldn't listen to the logic of this argument either, because the feed wasn't costing him anything—he raised it himself.

The salesman was staggered, but struggled manfully on. Next he approached the economy of the truck from the standpoint of labor. One man could drive the truck while it required four men to drive the teams. His amazement may be imagined when the woodsman told him that the labor didn't cost him a cent either, because—his sons drove his teams.

Here was a man who produced his own horses, feed and labor. Everything, in fact, he raised himself, except his wagons and harness, and these weren't mentioned.

Ask the average farmer today what it costs him to use his teams and he will say that their only expense is the feed. The big business house of the large city would readily correct this impression by pointing out a number of charges that actually exist and that run into real money every day the horse works.—"Duplex Doings."

**GENERAL MOTORS TO BUILD
400,000 CARS**

General Motors is lining up this year for a production of 400,000 cars which will be distributed as follows:

- Chevrolet 200,000
- Buick 100,000
- Oakland 50,000
- Cadillac, Scripps-Booth and Oldsmobile to make up the remaining 50,000.

At the moment General Motors has an outside capacity of approximately 500,000 cars but when the eventual plans for the extension of the Buick and Cadillac factories are completed, 700,000 will more nearly represent its possibilities. At present Buick capacity is only 150,000 cars, whereas when additions at Flint, Mich., and the

projected assembling plant in St. Louis are erected, it will be possible to ship 1,000 daily.

**DON'T BUY GOVERNMENT AUTOS
—THERE ARE NONE FOR SALE.**

The latest swindle to be reported is the sale of government automobiles which are alleged to have been brought back from France or surplus stocks left in this country.

The government has offered none of its military automobiles for sale and government automobiles will not be put on the market. When anyone tells you he has some government autos to sell—call a cop.

When bolting parts together do not try to make the nut pull the bolt through if the latter sticks. Take a hammer and drive the bolt into place. Otherwise the threads are likely to be ruined.

Benton's Recipes

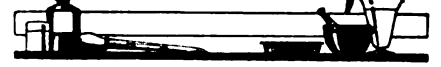

To Cut Cork.—In cutting cork, the knife is to be kept greased. Where, however, the desired piece is symmetrical about one axis, and of circular cross-section, it may best be roughed with a greasy knife and then ground to profile with a coarse emery. Where many pieces are to be cut out of sheet cork, it is advisable to use a band knife, against which there is kept pressed a block of grease.

Etching Fluid.—I have found the following receipt for a fluid for etching steel to be very satisfactory, both for frosting effect and deep etching. Mix 1 ounce sulphate of copper, ¼ ounce alum, ½ teaspoonful of salt (reduced to powder), with 1 gill of vinegar and 20 drops of nitric acid. This fluid can be used either for etching deeply or for frosting, according to the time it is allowed to act. The parts of the work which are not to be etched should be protected with beeswax or some similar substance.

Casehardening Process for Cold Rolled Steel.—To successfully caseharden common cold rolled steel so that it will answer for the cutters of inserted reamers, etc., pack the cutters in granulated raw bone in a cast iron box with at least one-half inch layer of bone between the cutters and the sides of the box. Put on an iron cover and lute with fire-clay; heat in a gas furnace to almost a white heat for from two to five hours according to the size of the box. Then draw the box, open and dump quickly into a bath composed of the following: 1 quart of vitriol (sulphuric acid), 4 pecks common salt, 2 pounds saltpeter, 8 pounds alum, 1 bound prussiate potash 1 pound cyanide potash and 40 gallons soft water.

Acid Hardening Bath.—To make an excellent hardening solution, mix pure rain-water and salt strong enough to float a raw potato, and to twenty gallons of the brine add three pints of oil of vitriol. Tool steel may be hardened at a surprisingly low heat in this solution, a very great advantage, of course, when hardening difficult shapes. The solution, however, has one slight disadvantage in that it causes the steel to rust quickly unless the steel is thoroughly scrubbed in strong hot soda water immediately after hardening. Tools hardened in this solution should come out of the bath a beautiful silver gray color and if there are any black spots they are likely to be soft.

Hardening Compound.—In hardening small tools, some of the more delicate and essential parts of the tool to be tempered are very apt to be overheated and burned unless extraordinary care is exercised. The following is descriptive of a compound that can be used to prevent overheating of such small delicate instruments during the process of tempering. Dissolve 2 ounces of pure Castile soap in enough warm water to make a thin paste, and add to it the contents of a five cent package of lamp black, mixing it well into a stiff paste. This must be kept securely sealed in a can. To use the compound, slightly warm the small tool or object that is to be hardened, and smear the paste all over it. When dry, heat and quench in the usual way.

CUTTING PINS WITH SHAPER

Confronted with the task of cutting up a lot of wire and rod into various short lengths the man of a mechanical turn built the arrangement shown and attached it to one of the shop shapers that

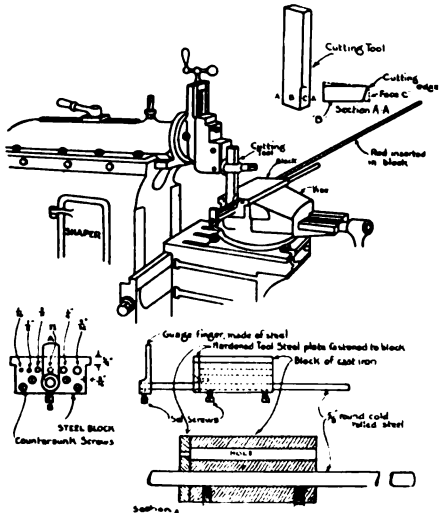

happened to be out of use. The shaper was speeded up and an apprentice put to feeding in the wire. The saving in time by this method can be appreciated, and the illustration shows how this device is made and operates.

THE WORK BENCH ON THE JOB

A portable bench such as the one shown in the illustration will save its cost many times over in added convenience and lessened fatigue at the end of the day's work. A bench of this sort is specially de-

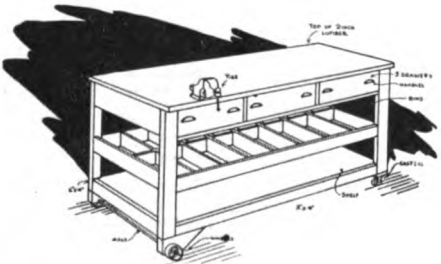

sirable in automobile work as it can be wheeled to all parts of the shop and can be placed between the cars and everything is right at hand. Portable benches such as this are used by millwright crews in large factories where they are long distances from their base of operations.

FINDING PUNCTURES IN TIRES AND TUBES

It is usually a difficult matter to locate a small leak or "pinhole" in a tire or tube of an automobile, bicycle or motorcycle unless the part containing the leak is submerged in

a tub or tank of water and even then it is often rather difficult to see the air bubbles in clear water.

The best way to locate such leaks is to slightly color the water in the tank with a little Laundry Bluing. The air bubbles coming from the puncture will show up white in the blue liquid and the puncture or slow leak can thus be located with a minimum of difficulty.

GASKET PUNCH

Every auto repairman and stationary engineer has often felt the need of a punch with which to punch the bolt holes in pipe, cylinder head and other gaskets, also it has probably never occurred to

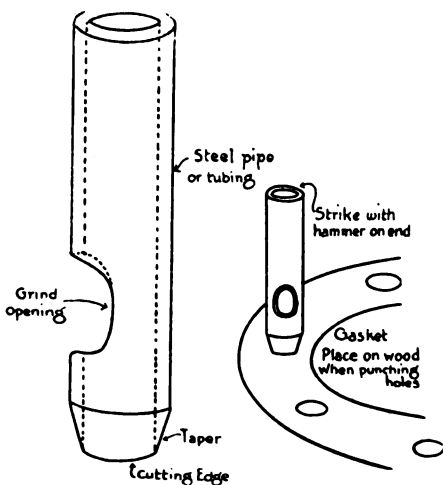

many to make a punch for the purpose—a simple matter as you can see from the illustration. Several of these punches of different sizes could be made without any great difficulty for the accommodation of different sized holes.

THAWING FROZEN PIPES

Thawing out frozen pipes when they run between partitions and other inaccessible places is the cause of a great deal of profanity, lost temper and not infrequently property loss through fires caused by various crude attempts at thawing.

The method shown in the sketch

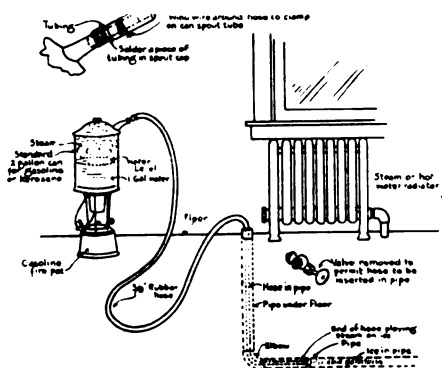

The Kink and

A PERMANENT FEATURE

We plan to make this department a regular and permanent feature of this magazine. To do this we will necessarily need the co-operation of our friends and readers.

Spend a few profitable minutes putting your ideas on paper and then send it along with enough of a description to tell what it is for and how it is made.

There are hundreds of good ideas knocking around the shop that you can think of that will fit in this department. A junk pile don't have any value unless you sell it.

Let us be the judge of whether it is good or not.

will be found to be simple and to do the work in a prompt and efficacious manner. The gasoline heater generates steam in the can which flows through the hose into the pipe so that it maintains contact with the ice. The hose will follow elbows and other pipe fittings.

SIMPLY MADE AUXILIATOR

The illustration shows an addition to a car that can be made and installed by anyone and on an automobile of any make.

All that is required is a piece of

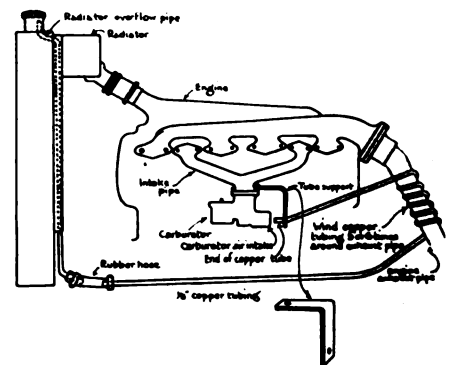

1-8 inch copper or brass tubing, one end of which is attached to the radiator overflow pipe with hose clamps or wire. The other end of the tubing is placed so that it is up against the air intake of the carburetor.

The advantage of this auxiliator is that it increases the mileage about 30 percent that it is possible to get from a gallon of gasoline and keeps the cylinder head and valves free of carbon.

Note Corner

BENCH CRANE

It is frequently necessary to lift heavy cylinder blocks and other bulky castings and parts from the floor to the bench and where there is no help available the workman is likely to seriously injure himself by attempting to lift them. The bench crane shown in the illustra-

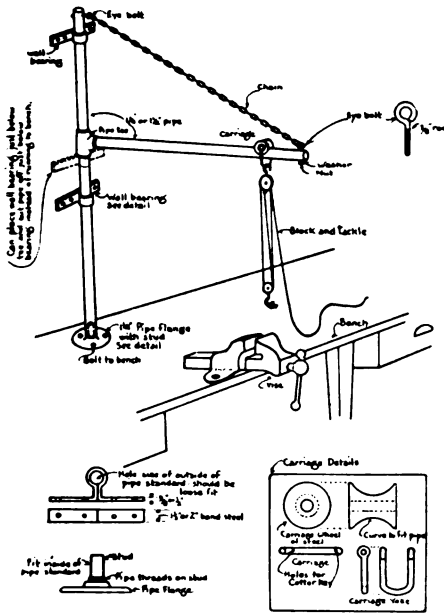

tion is designed to do away with this heavy lifting of parts from the floor to the bench or vise.

The length of the crane arm should be sufficiently long to extend for about two feet from the edge of the work bench. Other dimensions may be altered to meet individual requirements.

REMOVING PIPE FLANGES.

The illustration shows the construction of a simple device for the removal of pipe flanges. This

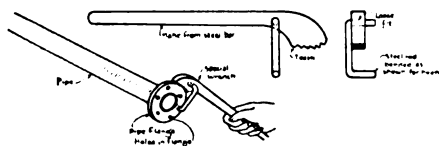

wrench is operated by inserting the hook in the bolt holes and exerting pressure on the lever as shown.

STOPPING THE LATHE

The ancient and accepted method of stopping the lathe is to place the left hand against the cone pulley after the belt has ben shifted. The accompanying sketch illustrates a

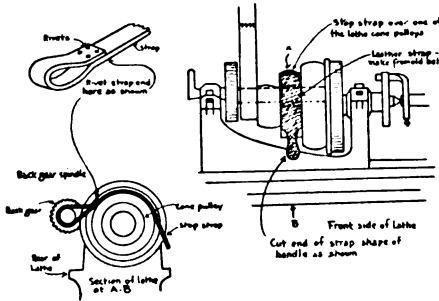

better idea. All that is necessary is to grip the leather strap at the handle and pull down on it. The strap can be shifted to any one face of the cone pulley.

USES FOR OLD RAILS

A substantial guard for walls and fences that are endangered by wagons or automobiles backing into them can be made of old rails which are heated and bent to the

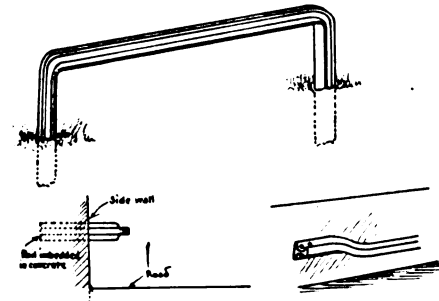

shape desired. The upper view shows a guard for the protection of a fence corner while the two lower views show similar guards for the protection of walls that may either be bolted to the wall or imbedded in concrete.

SAVING SOLES.

Rubber pads that cover the clutch and brake pedals and applied as shown in the illustration

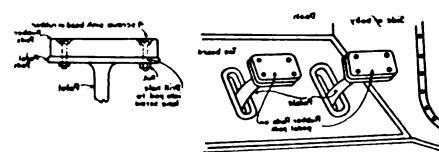

will result in longer life to the operator's shoes and will also prevent his feet from slipping off the smoothly worn metal pedals.

The rubber pads are cut from an old outer casing and bolted to the pedal with small bolts.

PREVENTING RUST ON TOOLS

In shops where there are sudden changes in temperature and more or less dampness, the mechanic's tools rust and as this interferes with the proper operation of the tools in many cases and a great deal of difficulty in removing the rust at any rate.

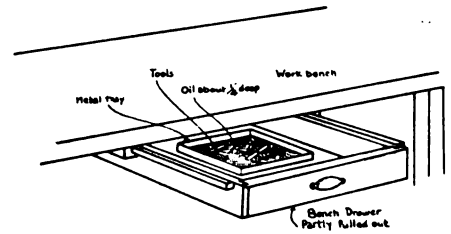

A shallow sheet metal tray is made to accommodate such tools as scales, squares, dividers, calipers, etc. This tray is filled about a quarter of an inch deep with lard oil or machine oil.

A GOOD SOLDERING PASTE

Procure some oxide of zinc and mix it with vaseline to form a paste. If too hard, use a little oil to soften the mass. A little of this paste spread along a seam will form a fine flux and will solder almost any metal except aluminum. It is necessary, however to scrape or otherwise clean the metal surfaces before applying the vaseline soldering paste. It is impossible to solder dirty surfaces. Clean first is "safety first" in soldering.

REPAIRING FEED PIPE

Small holes and breaks in gasoline feed pipes in all sorts of gasoline engines are not common but

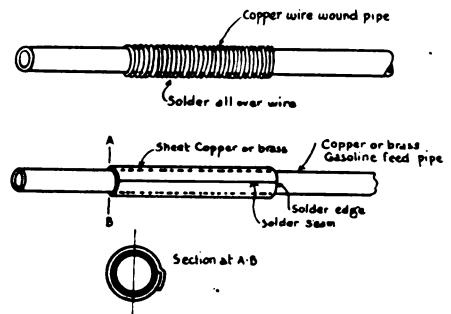

when they happen it is not always possible to replace the faulty line with a new one and emergency repairs must be made. The illustration shows two simple methods of repairing such breaks or leaks.

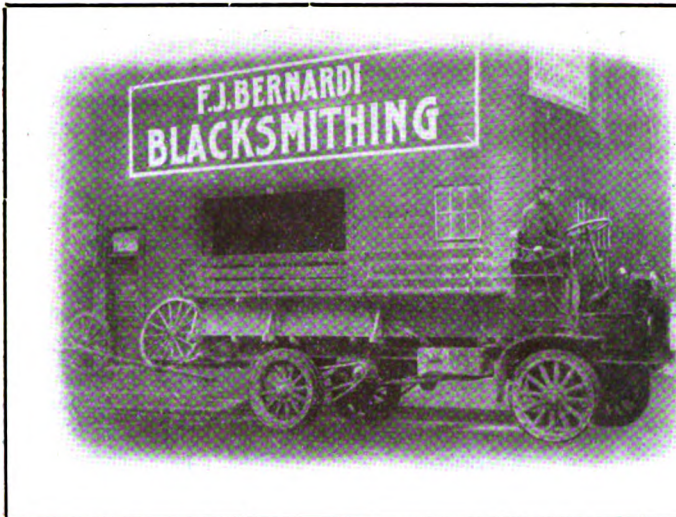

“I Quit Shoeing Horses Because —”

F. J. BERNARDI

The story of a man who saw possibilities in motor vehicles and began preparing for the day he would have to take up this work. Finds the work pleasanter, does a bigger business and makes more money than ever.

LAST APRIL I stopped shoeing for the good and sufficient reason that the other smiths in town refused to raise their prices and because I realized that I could make more money at other work which I had been considering for a long time.

When the automobile first made its appearance it seemed to me then that it had come to stay and by close observation I saw first one and then another of my customers exchange his horses for automobiles of various kinds.

Therefore, I reasoned that I must

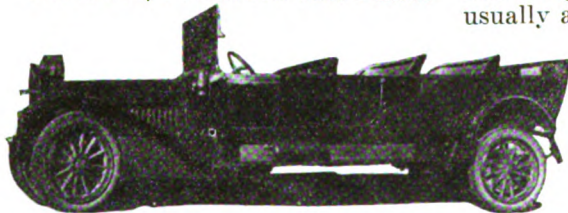

prepare to repair automobiles that my former customers were buying in increasing numbers. My first step in this direction was the purchase of a large number of automobile springs from my jobber. The roads hereabouts were very rough in those days and broken springs were common. I ordered these springs in lots of a hundred at a time and thereby was able to get them at bed rock prices and cheaper than my competitors and also I had the “edge” on them by being prepared for this work by having constantly on hand a good assortment of springs and naturally this brought other work to my shop.

In due time came the auto stages and the rebuilding of old seven passenger models to carry twelve, fourteen or sixteen passengers and this business has grown to considerable proportions. When a job is

completed and is ready to be turned over to the upholsterer we always have a photograph made of the job so that we can show our next customer what we can do for him.

I next considered a small truck attachment and at present I am selling two different makes and let me say right here that this is a better line to sell than automobiles for there are no demonstrations to make and no time wasted. In selling such attachments business is not only created for the shop in attaching them but also there is usually a body to be made.

Commencing with the New eYar I added a line of automobile tires to my business, and while

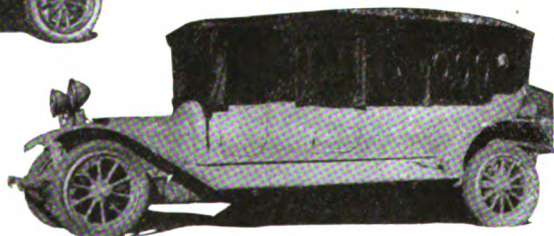

THREE EXCELLENT EXAMPLES OF CONVERTING OLD PIERCE ARROW TOURING CARS INTO AUTO STAGES CARRYING FROM 12 TO 15 PASSENGERS. MR. BERNARDI HAS ALL SUCH JOBS PHOTOGRAPHED BEFORE THEY GO TO THE UPHOLSTERER SO THAT HE CAN SHOW OTHER PROSPECTIVE CUSTOMERS WHAT HE CAN DO

sufficient time has not yet passed to give an opinion I feel that this line, from the showing it has already made, will be a big money maker.

At the present time I am employing four men in one shop; a woodworker, two blacksmiths, and one

all around man who removes springs and replaces them and does similar work and who also gets the work ready for the other men to start on. I also have a lathe operator for turning out steel parts and this man also does the oxy-acetylene welding and by the way, this is one of the most profitable elements of my business and as the work is done right, some of my welding jobs come for a distance of 90 miles. We do shoeing in another shop that I have just bought and unless I can convince my competitors of their mistake in working at their present low prices this shop will soon be converted to the auto repair business.

All of the men are furnished with time and material cards and they work by the hour instead of the job. We work eight hours per day and charge \$1.25 per hour and each man's card must total up eight hours for the day. All lumber used is meas-

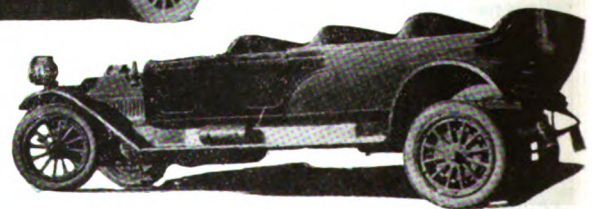

ured, all bolts and other small parts are counted and all metal whether sheet or bar is weighed, and where a small piece is used a certain percentage is added over the cost of a full bar. Each man must show on his card exactly what material he has used on each job. In this way I am able to keep accurate record of the material cost of each job with

a minimum of difficulty and as the man's time on each job is given on the same card it is simple matter to add my fixed overhead expenses and thus I am able at all times to tell just about where I stand in relation to profit and loss.

My principal motto in all transactions with my customers is "Fair Dealing to All My Patrons" and another one that I set considerable store by is "Short Accounts Make Long Friendships." The business of some of my best customers, men whose confidence has been gained by fair dealing they and rely on what I say. In this way and by preparing to take care of their requirements I have been able to serve a large number of my customers continuously for over twenty years. Another of my doctrines is that "I cannot run business for two or more men." I mean by that that if my competitors' ideas of business do not suit me, I don't waste time talking about them to my customers. Don't knock them for in doing so you are only knocking yourself.

I give my customers to understand that whenever credit is given a settlement is expected every thirty days unless a reasonable excuse is given. I have two large signs tacked up on the wall where all may see. One of them says "All Work Must Be Paid for on Delivery Except by Special Arrangement."

That means that all firms that make a practice of paying their statements monthly are collected on that basis. All other work is charged cash when taken from the shop. In this way I am avoiding a flock of bad accounts and the loss in time that I would sustain in endeavoring to collect them. The other sign that I referred to states that "On and after Jan. 1, 1918, \$1.25 per hour plus cost of materials will be charged." This, as well as the other sign are printed in large letters so that anyone entering the shop can see them and if the price or the payment arrangements do not suit them they need ask no questions or leave the work.

I believe that in having my shop equipped with the best labor saving tools obtainable I can save the time of my men and thereby produce a greater quantity of work. On this basis my shop is equipped with two electric blower forges; power hammer, located so that it is convenient to both fires; power drill; emery wheels, coarse and fine;

Temco twospeed electric portable drill; two swinging cranes of 3,000 pounds capacity and equipped with Duplex chain blocks; 32 inch band saw; 12 inch jointer; planer; wood boring machine, and have under construction a special lathe for the remodeling of automobile wheels so that they will conform to the lately standardized sizes of tires. In addition to the foregoing equipment I have an eight foot metal turning lathe and my oxyacetylene welding outfit.

I am a staunch believer in the value of newspaper advertising as it serves to keep your name before the public.

Before this will reach you I will have installed a 250 ton press so that I will be able to take care of the solid rubber tire trade which is on the increase.

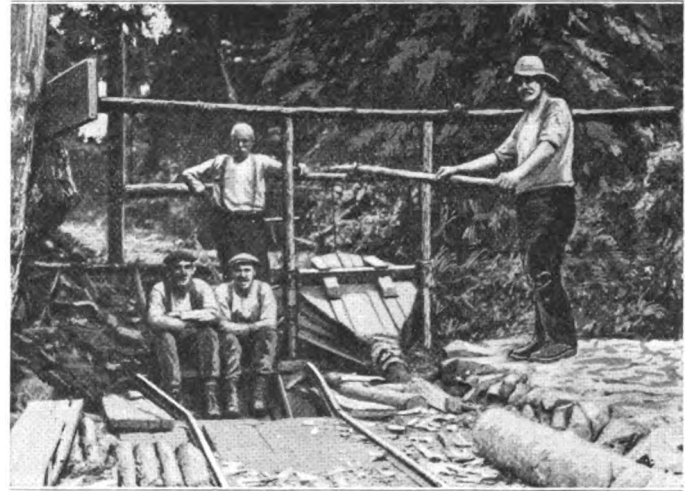

Courtesy Popular Mechanics.
BELLOWS INSTALLED AT THE MOUTH OF A MINE SHAFT IN BRITISH COLUMBIA, WITH WHICH FRESH AIR WAS FORCED DOWN TO THE MINERS: THE MAN AT THE RIGHT IS TAKING HIS TURN OPERATING THE BELLOWS

VENTILATE MINE WITH BELLOWS

Fresh air being urgently needed in a coal mine in British Columbia, and there being no suitable ventilating apparatus available, a bellows was obtained from a blacksmith shop and rigged up for use in the emergency. A framework of poles supported it and furnished a leverage for operating it. The miners worked the big bellows in shifts, sending fresh air to their fellows down the shaft by pipe line.

Electric Welding—II.

A. F. DAVIS

SOME difficulties in the metal electrode process are sometimes encountered if the proper equipment is not used, owing to the sticing or freezing, as it is called, of the electrode to the work. This is caused by an inrush of current owing to the fact that the machine is short circuited when the connection is made. This short circuit causes the metal to melt and fuse to work before the operator can withdraw the electrode and start the arc. Attachments have been made to eliminate this difficulty as far as possible, which has been more or less successful. The best solution so far has been obtained through the use of what is known as a stabilizer or reactance coil. This attachment, while not mentioned above, is shown in the various photographs,

and consists of a large coil. The resistance of this coil is very low, so that the power lost can be practically forgotten. It acts a good deal as a fly wheel on a gas engine in smoothing out the current variations. When the current has a tendency to stop the stabilizer gives up its stored energy of electric power, and has a tendency to force the current, thus continuing the arc. This is exactly the same as the gas engine illustration, as the fly wheel gives up its energy between explosions, forcing the engine to continue to run. It not only prevents the inrush of current mentioned, but also has a tendency to keep the current flowing more evenly and enables the operator to maintain his arc more continuously.

Figure 142 shows the tools usually required by the operator, aside

from the equipment to furnish him with the proper current.

In striking the arc the electrode should not be stuck straight down on the work, but a small swaying motion should be made, similar, on a small scale, to the striking of a match. After some experience with the proper equipment, the striking of the arc and the maintenance become very easy.

After the arc is struck, we come into the third phase of welding mentioned above, namely, the manipulation and maintenance of the arc and filling in the metal on the parts to be welded. This can best be accomplished through exper-

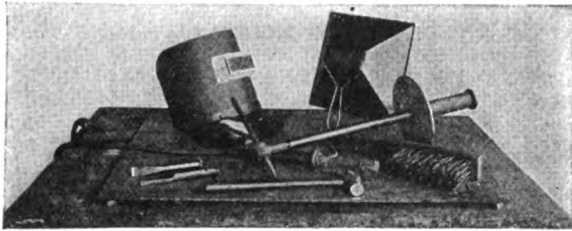

FIG. 142. OPERATOR'S TOOLS

ience. Directions and theories may be given, but like a good many other things, effects are only obtained through experience and practice. After striking the arc, the metal electrode is moved back and forth with a circular motion in order to bring the metal of the material and electrode to the proper condition at the same time and to properly place the metal.

With the carbon electrode, the arc should be played over, not only the actual spot to be welded, but on the surrounding metal. When the spot to be welded is in a molten state, the filler rod is introduced into the arc and melted into the work. In the manipulating and planning of the weld, care must be taken regarding expansion and contraction of the metal. With electric welding the work to be welded and the electrode are brought to a welding temperature almost immediately. The heat is intense and confined to a small area and unless care is taken the resulting expansion and contraction after the weld is made is liable to give trouble. This difficulty can usually be overcome, however, by experience.

A word may be said with regard to the size of electrode to be used with the different classes of work. Different operators have different ideas regarding this subject, but the following may

be used as an average figure:

| Thickness of plate | Diameter of Electrode | Average Current |
|----------------------------------|--------------------------|------------------|
| $\frac{1}{8}$ " | 1-16" | 60 to 70 amps. |
| $\frac{1}{4}$ to $\frac{1}{2}$ " | $\frac{1}{8}$ " to 5-32" | 110 to 140 amps. |
| $\frac{5}{8}$ " and above | 3-16" to $\frac{1}{4}$ " | 140 to 200 amps. |

Metal electrode of larger diameter than $\frac{1}{4}$ " is not practical owing to the sputtering of the arc and the splashing of the molten metal, resulting in difficulty in accurately placing the metal and a porous weld.

A good deal has been said about coated electrode. As a general rule, we may say that the coating is unnecessary in the majority of cases, and if the weld is not thoroughly cleaned as each layer of metal is placed in, a good weld will not be secured with this kind of electrode.

A competitor of the electric arc process is the acetylene gas, and with this process the majority of readers are more or less familiar.

While we will not take the time to go into detail, we may say, that the big majority of jobs that can be done by the acetylene process, can be equally well done by the electric arc, and at a very small fraction of the cost. The primary or first investment is considerably higher, but the operating cost is so much less that the equipment will usually pay for itself in the saving over the gas. These savings are effected in three ways:

First: Heat itself may be produced more economically by the electric arc than by the gas process.

Second: Owing to the fact that the heat thus produced is concentrated into a very small area, no energy is lost in heating up the work unnecessarily.

Third: The moment the arc is broken or actual welding stops, practically all the input to the machine ceases.

With the gas process we find that frequently the operator stops welding for different reasons, to arrange his work, etc., and in the meantime the flame is going on at practically full blast, burning up acetylene and oxygen.

Taking into account these three economies, and comparing only the cost of oxygen and gas against the cost of power, we find that the cost of power will only run 10 to 20% of the cost of gas for any particular

job. These figures are, of course, general, and may vary somewhat on particular applications.

We are very often asked "What element is most success in securing a successful weld?" Without hesitation we will say at once, "The Human Element". Good operators are absolutely necessary for successful welding. With the best machine and best electrode in the world, a successful weld cannot be obtained unless the operator knows his business. It is like any other skilled process; it requires good common sense and experience. While a man may learn to maintain an arc in a day or two, it does not mean that he is a good welder. In learning to weld a man must spend a considerable amount of time in merely depositing beads of metal on a scrap plate. This will give him skill in maintaining the arc, and in this way he will learn to detect when he is making a good weld and when he is merely melting metal. Before starting on any actual welding work the operator should be able to tell instantly whether the metal he is depositing is actually fusing to the work or only sticking. These remarks, however, should not discourage any one, as there is no reason in the world why any one, who has a fair amount of intelligence, cannot become a skilful operator.

WISE JAWS FOR TUBING

Very often one has to grip a piece of polished pipe or tubing in the

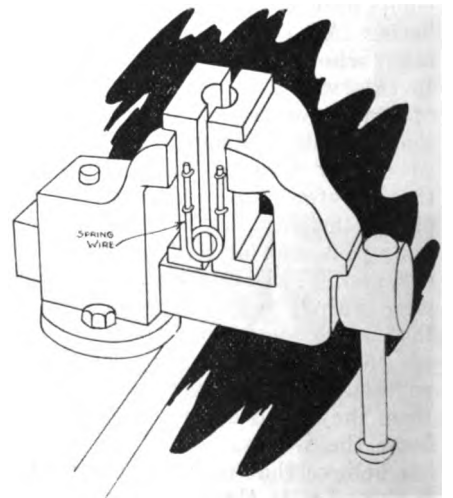

wise while threading its end, drilling holes in it or flaring out the ends. When such work is met with, there is need of suitable jaws for the vise that will not mar the work. Such jaws can be made from good hard wood, as shown in the sketch.

C. H. Willey.

HOW AUTOS ARE PAINTED

Charles C. Spreen

Automobile bodies are usually made of sheet metal which conceals a wooden frame work. Of course in its unfinished state such a body is most unattractive in its appearance and a coat or so of paint is in order before the body can be considered as "finished."

The body, minus, upholstery and fittings is placed on a truck, as shown in the picture and this is surrounded by a horseshoe shaped pan into which the superfluous paint is drained. The paint is flowed on to the body in a stream about three inches wide and 1-8 of an inch thick from a nozzle which is controlled by a valve in the hands of the operator and which can be opened and closed at will by pressure on the valve lever.

The paint is furnished by a continuous circulating system which is pumped from a large supply tank through suitable pipes which are seen on the ceiling and down a vertical pipe provided with a swivel joint which allows the operator to work in a circle about the body.

The surplus paint that drains off into the drip pan is pumped back into the main supply tank and is used over and over again.

In other factories the paint is applied in a fine spray by means of compressed air. These body finishing methods are only used on the lowest priced cars where quantity production and lowness of price makes the niceties of a hand rubbed finish out of the question.

The chassis are placed on trucks

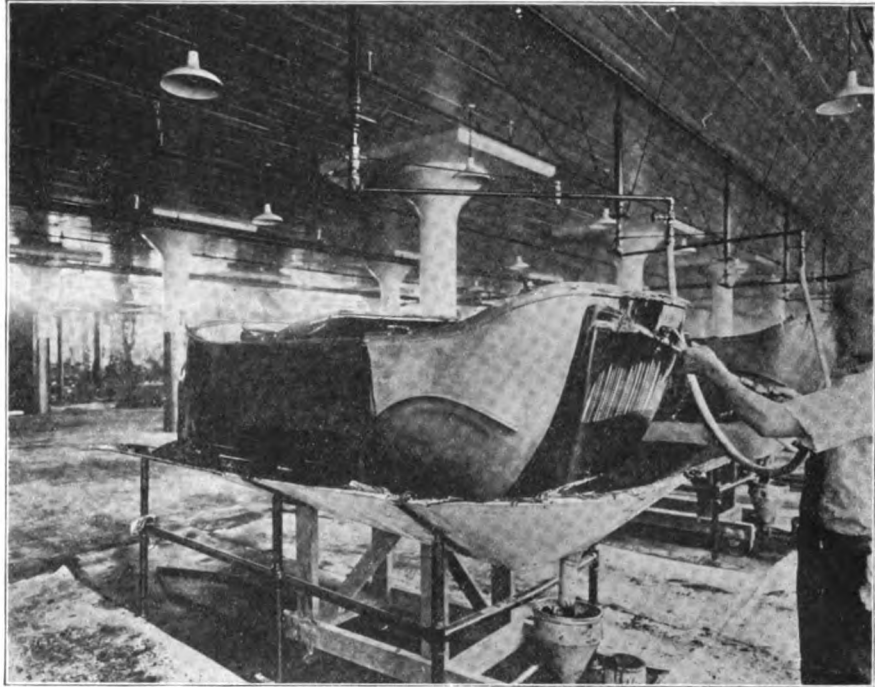

APPLYING THE PAINT TO THE BODY. THE SURPLUS PAINT DRAINS INTO THE PAN AT THE BOTTOM AND IS USED OVER AGAIN

and the paint is sprayed on by a glorified sort of air brush. The truck bearing the chassis runs on a track and between the track runs and endless link chain which has dogs on it at intervals and which catch the trucks and draws them through the drying oven.

The illustration shows a drying oven containing two tracks and about 120 feet in length which is maintained at a high temperature by coils of steam pipes. The journey through the drying oven occupies less than an hour and when the chassis finally makes its appearance at the other end of the oven the paint is completely dried.

In some cases where the progressive assembly system is used the

chassis coming from the drying oven is so hot that it passes through an air blast which cools it sufficiently to be handled by the assemblers who place the wheels, bodies and other fittings on the upper part of the car.

DIRTY GARAGE IS KNOCK ON BUSINESS

Nothing stands against a garage or repair shop so much as a slimy black floor, oil begrimed walls and pillars and shop or floor men clad in overalls that, like the printer's towel, will stand alone. Such things are excellent to drive away trade, for it naturally comes to a customer that as the shop or garage is kept so will be the work performed.

A garage floor once thoroughly cleaned of grease easily is kept so with the application of a little work each day and the use of clean white sand where the cars stand so oil drippings will be caught and absorbed by the earth.

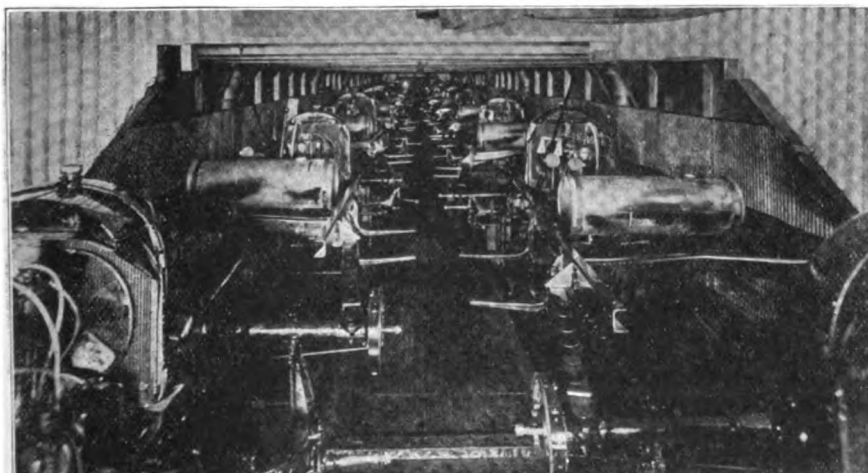

THE CHASSES AFTER BEING PAINTED GOING THROUGH THE DRYING CHAMBER

À GOOD IDEA

If you have a dollar and I have a dollar and we swap, then we still have one dollar each. But if you have an idea and I have an idea and we swap, then you have two ideas and I have two ideas.—A.A. C. Bulletin.

And if you send that "idea" along to the Editor then fifteen thousand others can get the benefit of it, too.—Editor.

Copyright U&U



TODAY
The country's busiest thoroughfare Fifth Avenue, New York. Only one ancient horse drawn hansom cab in sight.

UNUSUAL HAMMER FOUNDATION

E. M. Peterson

In a certain repair shop we had a steam hammer that had been out of order for a long time. The anvil block was leaning badly to the north and the rest of the hammer was leaning in the other direction and anyone can imagine how difficult it was under these conditions to do a decent job with such a tool. When the proper authority got good and ready he took down the hammer and dug a hole that looked like a shell hole "somewhere in France." He discovered that the sandy soil "kept on going" with no sign of earth or rock vein that would make a suitable foundation. About two feet of the pit was filled with concrete and on top of this was placed a granite slab about six feet square and 14 inches thick. A square space in the center of this slab was leveled off for the anvil block and the remainder of the hole was filled with concrete, even with the timber and flush to the floor. After a day or so the whole foundation was covered with earth and this was soaked with water every other day for six or seven weeks. Then the earth surrounding the base was removed and a few pieces of hard wood were placed in the bottom of the square space and the anvil block was set down and the hammer placed on the foundation.

Everyone told him that the ham-

mer would fly up through the roof on account of the big stone slab under the anvil block. After we began to use the hammer we found it very satisfactory even with the rough treatment it received when working with hard die steel from the smaller sizes to five inches square as well as cutting a great deal of cold stock.

This foundation stood up in good shape for nearly 15 years when the hammer was lifted for some minor repair and the foundation was found intact and in good condition with the exception that it was a small fraction of an inch off on one side.

WHY MAIL ORDERS?

Mail order houses are keen students of the human mind. Without cost or effect to the individual they bring pictures and descriptions, together with prices of

articles which will appeal to everyone, in the convenient form of bulky catalog to the home fireside. Here the would-be purchaser can follow the line of least resistance and order without the expenditure of time or much effort. To prevent the feeling that the purchaser is not buying a "cat in a bag," most of the mail order houses give the assurance "Money back if you are not satisfied." They know that even if the satisfaction is not complete, few will take the trouble to pack up and re-ship goods and write one or more letters in explanation of the return. The man on the ground with a local business has the advantage if he will only make buying easy for the people about him. What are **you** doing to show accessories to the people who have never thought they had reason or need to come into your place of business?

YOU'LL HAVE TO TAKE TO THIS WORK—IT'S COMING TO YOU WHETHER YOU WANT IT OR NOT

| | |
|---|---------|
| Fordson Tractor output for 1919..... | 100,000 |
| Moline Tractor Co., output for 1919..... | 25,000 |
| Total production for 1919 of but two tractor companies..... | 125,000 |
| Ford Company will produce in 1919..... | 300,000 |
| Scripps-Booth will produce in 1919..... | 10,000 |
| Franklin will produce in 1919..... | 10,000 |
| Studebaker will produce in 1919..... | 7,000 |
| Total estimated production of but FOUR automobile in 1919.... | 347,000 |

The production of other big concerns like the Chevrolet, Reo, Maxwell, Overland, Oakland, Buick, Chalmers Hudson and etc., will bring to total automobile passenger car production ALONE, exclusive of trucks and tractors for the year approximately 1,000,000 cars. Probably half a million trucks of all kinds will represent the year's production in this field.

The facts are as plain as the nose on your face—this work will come to you whether you want it or not. If you are prepared you can "cash in" if you are not—aw, what's the use?

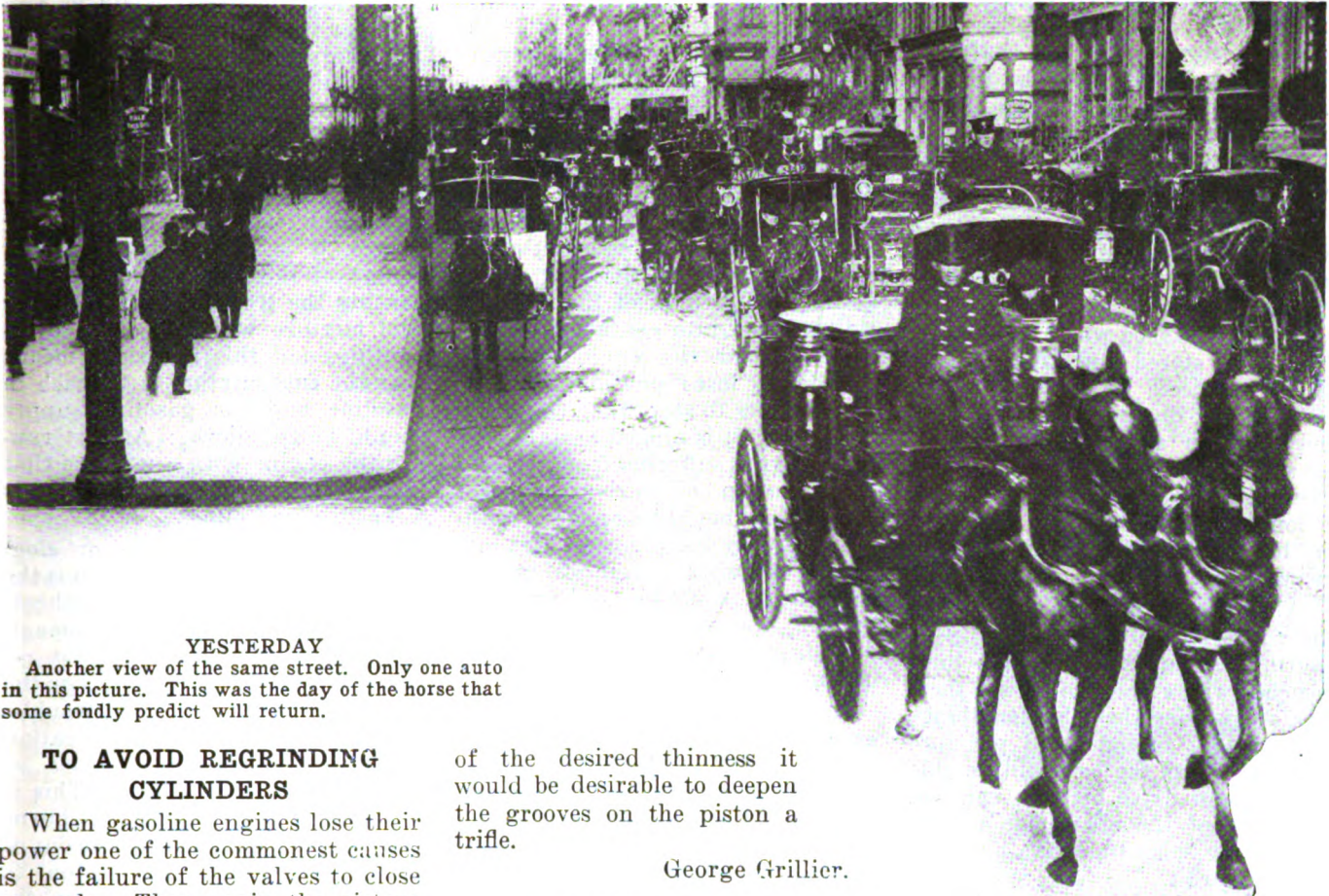

YESTERDAY

Another view of the same street. Only one auto in this picture. This was the day of the horse that some fondly predict will return.

TO AVOID REGRINDING CYLINDERS

When gasoline engines lose their power one of the commonest causes is the failure of the valves to close properly. Then again the pistons may be worn and in this case the best thing to be done is to have the cylinders reground or rebored and fitted with oversize pistons and rings. Also it is always better to have all the cylinders reground than one or two as it is almost certain that all the trouble will have to be gone through later. When considering regrinding cylinders the cost of this job should be compared with the cost of a new cylinder casting which is sometimes cheaper and far preferable.

Occasionally it happens that it is impossible to lay up the car until the cylinders are reground and in such cases the operation can be delayed by removing the piston rings and cleaning out the grooves on the piston thoroughly. Fit into the grooves a piece sheet copper of the proper thickness to compensate for the wear. The ends of this copper should not overlap as that would cause a high spot and trouble. The piston rings are replaced and as the copper expands considerably on the application of heat considerable judgment should be used in the selection of the the proper thickness of copper backing. In some cases where it is not possible to obtain sheet copper

of the desired thinness it would be desirable to deepen the grooves on the piston a trifle.

George Grillier.

DID YOP BUY ANY?

Indictments against thirteen officers and directors of the Pan Motor Co., of St. Cloud, Minnesota, charging use of the mails to defraud have been returned by the Federal Court. The indictment alleges a stock jobbing scheme.

The indictment charges that approximately \$5,500,000, including \$250,000 in Liberty Bonds, was accepted from 50,000 working people throughout the country.

A recent financial statement issued by the company, the indictment states, claims that the company had a surplus of \$2,500,000, although it was never on a production basis. The surplus, it is charged, was created by capitalizing intangible assets.

REMOVING BROKEN STUDS

There are many ways in which a blacksmith can use his oxy-acetylene outfit in the day's work. Recently one smith worked a pretty good stunt. A farmer brought in part of a tractor where a stud had broken off short so that it was hard to remove same. The smith simply grabbed his torch, welded a square piece of stock on the end of the

stud, then unscrewed the broken end with a wrench.

STOCK ACCOUNTS

"Old Timer."

How many men keep a stock account, or at least take an invoice, once a year?

Can a man run a shop without taking stock at least once a year?

The average shop owner says, "I know what I have on hand," but does he?

When it comes down to brass tacks, does he actually know within a good many dollars how much he has in his shop?

He doesn't know whether it cost him a dollar or fifty cents or when he bought it.

I can cite an instance where a man sold out after having been in business for some two years at one place and had never taken stock.

He decided to sell out and go into some other line of business and lumped the stock and tools off at \$500.

The new man listed up the stock from the original invoices and it footed up \$416.20.

The tools consisted of a 3 h. p. motor, a 50 pound trip hammer, drill press, emery grinder, line shaft and hangers and pulleys, spoke tenoner and hub borer in addition to the usual assortment of small hand tools.

I think this is a fair sample of the way a good many men keep shop.

A shop owner in a nearby town was looking for a piece of hardwood to make a buckboard slat from and I happened to be in the shop. He went into the shed where the lumber stock was stored and after moving a lot of pieces he found what he wanted and during the hunt he uncovered four axle sticks. "Well," he said, "that is lucky. I just need these and they have been lost for a long time." This man had been in business for 22 years and had never taken an invoice.

All kinds of small tools and materials have the annoying faculty of getting lost in dark corners behind benches where one cannot see them and the sooner these hidden things are brought to light and put into use the sooner the boss will be able to own and drive his own car and see some of the other man's town and at the same time give his tired muscles a rest.

OVERHEATING AND ITS CAUSES

J. L. Haky

Overheating is not a hot weather ailment of the automobile engine, for it often occurs under weather conditions of the severest and coldest kind. Generally overheating is not given the attention that it demands, the owner considering it more of a nuisance than anything else. Occasional overheating is not particularly harmful, but let this condition become chronic and the engine begins to deteriorate rapidly, and therefore, over heating should be promptly traced down and the cause removed.

Numerous things cause the engine to overheat, some of them entirely mechanical, and still others are the fault of the driver, and the driver is responsible for one of the most frequent causes of overheating by driving the car with the spark retarded too much, and naturally as the spark occurs late and the piston is on the downward stroke before the explosion occurs, more of the cylinder is exposed to the heat that results and as a result the temperature is increased considerably.

To keep the engine from knocking in driving up a steep hill, it is

often necessary and highly desirable to retard the spark, but if the hill is a long one, it is generally observed that the water in the radiator is boiling.

Another prolific source of overheated engines comes from accumulations of carbon in the cylinders and carbon gives rise to overheating, because it causes the explosion to occur at the wrong time and a greater area of the cylinder walls comes into contact with the heat. When the engine knocks, overheats, loses power, backfires, and declines to stop when the spark is shut off, it is almost certain that the engine is suffering from a heavy accumulation of carbon, and of course this should be removed without delay by scraping or burning. When carbon accumulates in this fashion it is useless to introduce any of the various carbon compounds into the cylinder—it's wasting money.

Any obstruction in the water cooling system will also cause overheating, because the water is hindered from circulating and becoming cooled in its passage through the radiator. The water rapidly reaches the boiling point and if there is no sign of circulation, even if the engine is running, then you may be certain that there is something that is interfering with the free flow of water, and the location and causes of overheating from this source depends altogether on whether your car is equipped with a pump or a thermo-siphon system. When an engine equipped with a pump refuses to circulate, the cause is generally, although not always, the result of some mechanical trouble, whereas, with thermo-siphon systems the cause is more likely to be scale or other foreign matter in the radiator. By opening the drain, the speed at which the water runs out will indicate the seriousness of the obstruction. There is a tendency for impurities in the cooling water to collect in the bottom tank of the radiator, and hence it is good policy to keep the thermo-siphon water system thoroughly cleaned out, and this is equally applicable to cooling systems using a pump.

A number of the higher priced cars are equipped with thermostats which do not open until the water has been heated up to a point where the engine will operate well. This is quite an advantage in the economical operation of the engine as

well as a considerable aid in cold weather starting. However, should the thermostat stick or refuse to work the water would be prevented from circulating and overheating would result.

When it has been found that a chronic case of overheating cannot be traced to any of the foregoing causes, it is likely that improper timing of the valves or ignition is causing the trouble. An improper fuel mixture will also cause overheating, and this naturally means that the fuel mixture is too rich in gasoline and the gasoline supply should be cut down. At best running the engine with a mixture that is any richer than can be avoided is a waste of gasoline.

Insufficient lubrication or clogging of the lubricating system is the most dangerous source of overheating. The others are all bad enough and annoying enough, but it remains for lubrication, or rather the lack of it, to cause the real trouble. Naturally, if there is no lubrication we have friction, and friction, as we all know, causes heat. This is the kind of overheating that burns out bearings, warps cylinders out of round and causes the piston to "seize" or expand to such an extent that they can neither be moved up or down. A bad case of overheating of this character generally leaves the engine ready for the junk pile.

DEGREE OF GRADES

Nine times out of ten when you hear someone talking of a 10 per cent. grade, or a 10 degree grade, or a 15 degree grade, and a 15 per cent. grade, the chances are that he hasn't the faintest idea of what he is talking about. No difference is made between the words "per cent." and "degree" and generally the speaker makes the mistake of believing they are the same thing. The degree of grade is not the same as the per cent. of grade.

The per cent. of grade is measured by the number of feet the grade rises in a distance of 100 feet. The degree of a grade is the number of degrees of a circumference which would be contained between two lines drawn through the point where the grade begins to rise, one horizontal to the ground before the grade begins and the other drawn along the surface of the ground up the face of the grade.

The following comparative table will make this clear:

A 10 per cent. grade, rising 10 feet in 100 feet is a 6 degree grade.

A 20 per cent. grade, rising 20 feet in 100 feet is a 11½ degree grade.

A 45 per cent. grade, rising 45 feet in 100 feet is a 24½ degree grade.

A 10 degree grade rises 17 feet in 100 feet and is a 17 per cent. grade.

A 20 degree grade rises 36 feet in 100 feet and is a 36 per cent. grade.

A 45 degree grade rises 100 feet in 100 feet and is a 100 per cent. grade.

A comparison of the two tables will show quite a difference between the meanings of "per cent." and "degree", as they are commonly applied. It might be possible for a truck or tractor to draw a load up a 45 per cent. grade, but it is quite likely that a 45 degree grade would prove quite insurmountable.

In common practice, both on the road and on the farm, 10 per cent. and even 20 per cent. grades are not uncommon, but a 20 degree grade is rarely encountered.

In tractor operation each rise of one foot in a distance of 100 feet, or a 1 per cent. grade, adds 1 per cent. to the weight of the load, or to the weight of the plow and of the tractor itself. If a tractor weighs 5,000 pounds and the plow 650 pounds, a total of 5,650 pounds, then for each per cent. of rise there must be added to the weight of the load the engine is pulling 56.5 pounds, or 565 pounds on a 10 per cent. grade. This is about the power required to pull one 14-in. bottom 6 inches deep through soil of average resistance, and a tractor which would handle easily a three-bottom plow on level ground likely would be reduced to two-bottom capacity on a 10 per cent. grade.

The fact that a tractor sometimes fails to do the work expected of it is often the fault of the implement with which it operates. Especially is this true in the case of plowing. A tractor which requires three or three and one-half gallons of gasoline per acre when drawing plows that have been used a good deal and are not in absolute adjustment may use only one and one-half gallons when drawing plows that are in good working condition.

SMOKE INDICATES TROUBLE

Smoke at the end of the exhaust pipe of a tractor or automobile indicates conditions in the motor which

GETTING THE FLIVVER'S GOAT

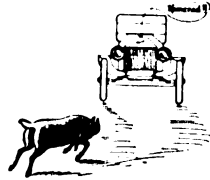

City Judge James E. B. Harrington, of Tonawanda, N. Y., is a man with a reputation. He acquired it recently when he fined Paul Belstead, the owner of a goat, \$56 and costs. Belstead's goat butted the Ford car belonging to Leon Beagle, of the Niagara Falls boulevard. The car was injured and the goat was not so the righteousness of the judgment cannot be questioned.

Judge Harrington stated that he did not lay any blame on the goat but that the owner was negligent because he permitted the animal to run at large.

every operator should understand. If the fuel mixture is too rich the smoke will be heavy and black and the difficulty should be remedied by feeding less fuel. A bluish smoke indicates excessive lubrication in the cylinder, but it may be well to let the motor run for a while before adjusting the supply of oil, because the condition may be only temporary. If it persists, slightly less oil may be used. When the smoke has a grayish appearance, the fuel has too much water in it. With kerosene motors this requires throttling down the water valve. Sometimes smoke appears at the open end of the cylinders. In this case look for leaky piston rings or overheating of piston and cylinder. Overheating may be due to late spark, poor lubrication, insufficient water or trouble in the cooling system, in which case the source of the trouble must be sought and corrected. Leaky piston rings may be located by testing compression and when found should be replaced by new ones.

GLASSY VALVE SEATS

Frequently difficulty is encountered in refacing the valve seats of internal combustion engines owing to the glassy surface of the metal. The seating tool will not "bite" and chatter. To prevent these

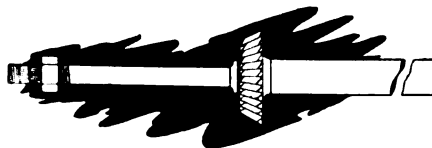

troubles the end of the guide on the valve seating tool was threaded and a nut screwed on to it. By first placing the tool in place and then tightening up the nut a steady pressure is obtained that effectively prevents chattering.

George Grillier.

DEVICE FOR TOWING IN CARS WITH BROKEN AXLES

When the garage man receives a call from a motorist several miles from town, stating that the rear axle of his car is broken and asking for quick action in getting them into town, the garage man is sometimes at a loss as to how to proceed. Replacing a rear axle on some of the older cars, which did not have the full or semi-floating axles, was often quite a job and one which was not easy to do when on the road without bench, vise and suitable heavy tools necessary.

We had received numerous calls of this sort and in order to handle them more easily and quickly, used this method of getting the car into the shop and found it very successful. We took a piece of lumber about 10 ft. long, about 6 in. wide and about 2 in. thick and at a place about 3 ft. from one end and in the center of the board, chipped out a hole about an inch deep, and large enough in diameter to fit over the hub cap of a wheel. Six inches from each end we would bore holes large enough to take a ¾ in rope (if necessary more holes spaced nearer the middle of the board). When our "hurry-up call" came we would load our board and ropes into the car and off we would go.

We usually found the axle broken off near the hub of the wheel or just outside or inside of the roller bearing. In any event, the axle would be jacked up and the wheel replaced as near as possible in its proper place and the board applied along the edge of the running board and projecting about a foot past the wheel, the chipped out hole, after being smeared with grease, being fitted over the hub-cap of the wheel. The board was then secured by passing the ropes through the holes prepared and in the rear fastening to the spring or body of the car, while in the front the ropes were fastened to the running board braces and any other handy brace.

We found that with this arrangement we could tow the car about 4 or 5 miles per hour with no trouble, keeping of course an eye on the board and wheel to see that they did not part company. This proved more satisfactory for this service than the small wheel-carriers put on the market for this purpose.—H. S. Atherton.

ANSWERS TO INCOME TAX PROBLEMS

R. H. Butz

Question—The profits of my business for 1918 amounted to about \$10,000. How much income tax will I be required to pay on this amount?

Answer—If you are a married man you are allowed an exemption of \$2,000 together with an additional \$200 for each child under 18 years of age. On the first \$4,000 after that you are taxed at the rate of 6 per cent, and on the rest at the rate of 12 per cent. In addition to this normal tax there is a graduated surtax which applies to all incomes of over \$5,000. This surtax is one per cent on the income between \$5,000 and \$6,000, 2% on income between \$6,000 and \$8,000, 3% on income between \$8,000 and \$10,000, etc. Assuming that you are a married man with two children under 18 years, your tax would be calculated in the following manner:

| | |
|---------------------------------------|----------|
| Income | \$10,000 |
| Exemption allowed | 2,400 |
| Amount subject to normal tax..... | 7,600 |
| Tax on \$4,000 at 6%..... | \$240 |
| Tax on \$3,600 at 12%..... | 432 |
| Total normal tax | \$ 672 |
| Surtax \$5,000 to \$ 6,000 at 1%..... | \$ 10 |
| Surtax 6,000 to 8,000 at 2%..... | 40 |
| Surtax 8,000 to 10,000 at 3%..... | 60 |
| Total surtax | 110 |
| Total tax | \$ 782 |

Question—I am one of three partners, and the profits of our business amounted to approximately \$15,000 for the year 1918. Each partner draws a salary of \$3,000, but none of the profits of the business were drawn out by the partners. Will the partnership be liable for a tax on this profit?

Answer—Your partnership business as such is not liable to taxation upon its income, but the individual partners are each liable for the tax on his share of the profits of the business. If each of the partners own a one-third interest in the business, then each partner will be required to pay income tax on one-third of the profits earned, viz: \$5,000, and also on the \$3,000 received as salary. In this case each partner would have to report a total income of \$8,000, less the exemptions allowed to married and unmarried persons, as the case may be. The method of computing the tax for each individual partner

will be the same as illustrated in the answer given above.

Question—My wife receives an independent income. May she render the return for her income separately, or must her income be included with mine on the report I render?

Answer—If the husband and

| | |
|---|-----------|
| Total amount of sales for year 1918..... | \$100,000 |
| Inventory, January 1, 1918..... | \$10,000 |
| Goods purchased during 1918..... | 75,000 |
| | 85,000 |
| Inventory, December 31, 1918..... | 11,000 |
| Cost of goods sold..... | 74,000 |
| Gross profit | 26,000 |
| Cost of doing business (itemize expenses) | 17,000 |
| Net profit | \$ 9,000 |

wife each receive an independent income equal to or in excess of \$1,000, separate returns may be rendered. If, however, the income of either is less than \$1,000, but their combined income equals or exceeds \$2,000, a joint return should be rendered.

Question—We conduct a retail business and would like to know

The cost of goods sold may then be deducted from the gross sales, and the difference is the gross profit. From the gross profit may then be deducted the expenses of doing business, and the result is the net profit for the year. The following illustration will show how this is done.

Question—May we claim depreciation on our stock of goods as a deduction from gross profit?

Answer—Depreciation on goods held for sale is not allowed as a deduction, but the retailer may claim depreciation on the property used for his equipment, delivery equipment, fixtures, and other necessary equipment. Depreciation on your stock of goods would probably be taken care of in your annual inventory, as you would not inventory the value of an article at twenty dollars if it were worth only ten dollars, even though it had cost you more than ten dollars.

Question—Our corporation carries life insurance policies on the lives of a number of the members of the organization. Is the premium paid on these policies deductible as an item of expense from gross income. One of these policies matured during 1918 and the corporation received the face value. Must the amount thus received be reported as taxable income.

Answer—Premiums paid by corporations for insurance covering the lives of those interested in the business cannot be deducted from the gross income. The premium on such policies is in the nature of an investment rather than an expense, as the amount of premium paid will eventually be returned to the corporation, either through the death of the insured or when the policy matures.

To determine the amount of taxable income to be reported for the matured policy, find the total amount of premiums paid on this policy. Subtract this from the amount received at maturity, and the difference is the amount of taxable income to be reported from this source.

(Copyright, 1919, by Ralph H. Butz)

the shortest method of finding the cost of goods sold during the year.

Answer—If you are buying and selling merchandise you should find your profits for the year on the following basis: First, ascertain the gross sales or the total cash receipts for the year. Then add together the inventory at the beginning of the year and the total amount of goods purchased during the year. From this sum subtract the inventory at the end of the year, and the result is the cost of goods sold.

SIZING A THREADED HOLE

It sometimes becomes necessary to transfer the size of a threaded hole from some out-of-the-way place to the shop in order to make a piece to fit it. With proper tools this is easy; without them, it might be difficult. One thing is always at hand and that is wood. Whittle a stick tapering until it starts in the hole. Then turn it into the hole and a fair thread will be made on the wood. The stick can be carried in the pocket without risk of changing the size, as would be the case with the ordinary calipers.

Queries-Answers-Notes



THIS department is the meeting place where you are free to ask for information, answer questions, discuss shop matters and business conditions and any other notes you feel would be of interest to a fellow mechanic. Make use of this Department as often as desired.

Welding High Carbon Steel to High Speed Steel.—Please tell me how to execute a weld of high carbon steel to high speed steel. Is it necessary to use a special filler rod, or flux?—W. R., Pa.

Answer.—In welding high carbon steel to high speed steel, the edge to be joined should be beveled by grinding and then put together in perfect alignment and enclosed with fire brick, leaving a chamber just large enough to permit manipulation of the welding blow-pipe flame. This chamber quickly fills with the gas from the outer envelope of the welding flame and reduces oxidizing to a minimum.

A good open hearth high carbon steel rod of the proper size should be used as a filler in conjunction with either a cast iron flux or a brazing flux. After the weld is completed it may be advisable to reheat the tool to a cherry red and allow it to cool slowly in air slaked lime covered with asbestos paper. As some carbon is bound to be burned out this part can be recarbonized by reheating with the oxy-acetylene flame and the metal will absorb the carbon from the flame. The amount of carbon to be added can be regulated by the length of time the carbonizing flame is played upon the heated metal.

BARBER GOES INTO GARAGE AND REPAIR BUSINESS

“J. T. Campbell, the barber, has purchased the old Baptist church, which he intends to have remodeled and fitted up for an automobile garage and repair shop.”

According to this, which was taken from an Illinois newspaper, the automobile repair business is open to all comers, judging from the results that have attended the ventures of barbers, grocers, confectioners, etc., in the auto repair and garage business. There are still a lot of blacksmiths though, who feel that they are not competent to take up the auto repair business. If barbers can do it, the blacksmith certainly can make a success of it—what do you think about it?

Slipping Clutch.—What is the cause of a Ford car running with a jerky motion on low speed.

R. Franklin, Mass.
If the engine is not misfiring a bad or slipping clutch will cause a Ford to run jerkily. A worn universal joint will also cause such a motion.

S. S., New York.

Welding Without Preheating.—Do you know of any way that I can weld broken crank cases and cylinders without preheating. I see some claim that they can do it but do not know how it is done. The only way they can do it that I can see is by using some kind of cement.

Jacob Kling, Penna.

In Reply, it is not practical to weld cylinders or crank cases without preheating unless the break is on an arm or a lug, etc. In the body of the case or on water jacket of a cylinder, to make a weld without the necessary preheating is absurd. Any claims made in this respect are exactly contrary to the laws of physics which tell us that heated metals expand and that they contract when cooled—hence, preheating is necessary in all cases to prevent setting up strains that would either crack at the weld or at least cause more or less distortion, even should the weld hold.

M. K. Dunham.

No Luck in Horseshoes Any More.—“And I picked this thing up for good luck,” remarked Albert Fredericks, driver of a truck, as he threw a horseshoe from the steps of the Franklin Street police station, recently. Fredericks was arrested for parking his truck on Main street and told the police he had picked up the horseshoe on Main street a few minutes before he was arrested.

Bronze Connecting Rods.—We have received from—a shipment of bronze connecting rods for Fords. There is no babbitt bearings in them and there does not appear to be any provision made for fitting them with such bearings. We would like to learn something about such connecting rods and how they are applied as they are something entirely new to us.

Hardtner Auto Trading Co., Miss.

In Reply.—We have been able to obtain information on this subject from the manufacturers and we are able to give the advantages claimed, as well as what appears to be more or less of a defect, from our point of view.

The advantage claimed in the use of

WAR TRAINED OPERATORS WILL STIMULATE USE OF TRACTORS

One of the great drawbacks to the success of the tractor has been the lack of trained operators. Agricultural colleges and tractor companies have both struggled with the problem of making competent mechanics out of farm boys who had mastered nothing more complicated than the threading of a harvest needle, but the output was lamentably small. Uncle Sam, however, has probably turned the scale, and the tractor will have a better chance when the soldiers come home.

The war has required tens of thousands of drivers for motor trucks, tanks and

artillery tractors, and thousands more of repair men, assemblers, etc. Not all of these, of course, will wish to continue as truck drivers or tractioners after they doff their khaki, but no doubt many will capitalize their mechanical training and their new fondness for outdoor life by making some connection with the automotive industry.

As tractor and truck salesmen, dealers, service men and operators—as power farmers or contractors—these men will make their influence felt in a way that can hardly fail to be helpful, for Uncle Sam's training has been extensive and thorough. Field artillery, marine, tank, quartermaster and motor transport schools

were established at scores of points throughout the country and graduated the type of driver or mechanic who understood that life or death depended on his work. The first Ordnance Motor Section instruction school was established in August, 1917, at Peoria, Ill.

The illustration shows a section of the field artillery school at Camp Jackson, S. C., with 5- and 10-ton artillery tractors in the foreground and a pair of military tractor-trucks in the distance. The latter is a four-wheel drive truck with two gear sets adapting it for heavy towing or rapid carrying. The tractors are T-11 and T-16 “Caterpillar” models as armored and equipped for military use.



bronze connecting rods over the babbitt type of bearing is that the entire rod is made of a phosphor bronze alloy to give the best possible wearing surface. The claim is also made that this bronze bearing will last longer and there is no reason for disputing this claim, as the bronze being somewhat harder than babbitt this would be natural. The bronze bearings will resist a greater degree of heat than babbitt and wears smoother and with less friction than babbitt bearings.

Connecting rod bearings of this sort are attached and fitted to the crank shaft in the usual manner by scraping, but they must be fitted a trifle looser on the shaft than is generally the practice with babbitt bearings. The shaft must be allowed to move slowly and smoothly through the bearing.

A disadvantage of bronze connecting rod bearings that suggests itself would be that if this bronze bearing wears, then it is going to slightly lower the piston, provided the wear is in the upper part of the lower end of the connecting rod. To our mind it would also appear that a connecting rod of this sort would have to be somewhat heavier than the ordinary forged steel rod, and we all know that the heavier these reciprocating parts are the greater the resistance will be and hence more or less power is lost and the speed reduced. In the case of wear that would result in lowering the piston slightly one would also lose more or less compression and with a consequent slowing down and loss of power.

Repairing a Broken Pitchfork.—I presume you wonder what a cowman does with a blacksmith paper—well, I'll tell you. I get quite a few kinks from same. I sometimes make a pair of spurs and silver mount them, and sometimes a bit, besides shoeing the ranch horses. I also do other kinds of odd jobs around the ranch.

A couple of days ago a stockman neighbor of mine brought me a four tine fork with one of the tines broken off. He had been to town, but the "mechanics" there gave it up and said that they could not fix it and doubted that it could be fixed at all. I made a long scarf, tied the two pieces together with stove wire and then wrapped it with fine copper wire and put plenty of borax on it. I built my fire in the shape of a volcano and gradually brought the outfit to the fluxing point, and all that remained was to file off the stove wire that remained and polished the job off and there she was O. K. and as good as ever. Now you may want to know why Mr. Jones did not buy a new fork when in town. This was a "Barley" fork and he called it extra wide. The main part of this education I picked up from the A. B. and if the paper is good for an amateur it must be doubly good for a professional.

V. B. Strong, Montana.

Cooperative Life Insurance — Three years ago last August the writer was a traveling salesman for a blacksmith supply house and on "making" a town where I had two customers, I learned that one of them had died and the people of the community were making a subscription to bury him and assist the family of the deceased.

This incident set me thinking and on my next trip I had thought out a plan to relieve the dependents of blacksmiths. I

had the proposition typewritten out and as a result I obtained the signatures of 281 members of the trade to pay \$2 each for the creation of a fund to be paid the families or dependents of deceased smiths, payable on demand and presentation of proof of death to the appointed secretary.

We had two deaths in three years and we agreed to raise our assessments and pay one dollar per member on the death of any member of the organization and limit the membership in the society to 300. You see we are doing good and have the cheapest protection on earth. The writer has written to all members and asked their views toward making this a national organization. To date we have received 212 replies expressing willingness to extend the benefits of our organization to all members of the trade.

W. E. Aton, Kentucky.

Refacing Anvils.—Would like to ask you a question about having anvils refaced. I would like to know where this is done, whether anyone has ever had this done and also whether it pays to have an old anvil refaced and whether the anvil will wear as when new. Anvils being pretty high in price I have two anvils that need refacing if this can be done properly and reasonably.

Joseph Wilhelm, Missouri.

The Columbus Forge & Iron Co., Columbus, Ohio, aside from being the manufacturers of high grade anvils make a specialty of refacing old and worn anvils. The various questions may all be answered in the affirmative and refaced anvils will wear as good as new. Cast iron anvils cannot be refaced. The cost of refacing would be a great deal less, including freight both ways, than new anvils at the present time.—Editor.

Truck Ignition.—Why is it that almost every motor truck is equipped with a magneto ignition system when most passenger cars have battery ignition?

J. B. Ache.

Storage batteries cannot stand the vibration they are subject to on motor trucks and as the magneto proves satisfactory there has never been any particularly good reason for making the change.

Oxyacetylene or Electric?—In looking over the January number I see one W. R., of Michigan, writing in regard to welding. I also note price of welding gas and I think that gas must be high up there. I use WK Prestolite tanks and 200 foot Linde oxygen tanks. My acetylene tanks cost from \$5.40 to \$7 and the freight charges from the supply company adds \$1.04 to the price of each tank, so a "load-up" as I call it will cost from \$11.88 to nearly \$14.

I will advise him to let electric welding alone. If he don't make welding pay it sure is his fault.

I do welding, cutting, general machine shop work, auto and gas engine repairing and sell a few tractors on the side and also charge batteries.

I have an 18" swing lathe; power hack saw; power drill; air compressor with large tank, a good milling attachment for my lathe, two good chucks, a lot of lathe tools, forge and anvil, and I build and repair car springs. I have plenty of work for two men summer and winter.

In another letter I will give you some of my experiences with the welding torch and also I will tell you about a large casting I saved from the scrap pile.

I have about 100 pounds of brass saved up and I would like to do some brass casting. I have a large crucible. What must be mixed with the brass to make it good and thin so it will flow good? I am sure Benton knows. I, myself, have worked at the blacksmith trade for 14 years but quit it to go back to machine shop work.

An Old Reader of Your Paper.

Welding a Bell.—"What is the best method to follow in welding a crack in a town bell by the use of the torch?"

H. Keener, Penn.

Answer.—Usually bell metal is composed of copper and tin, in varying proportions, but generally three parts copper to one of tin. The welding rod should be about the same material, but an excess of tin is best. If you cannot get such a rod, use Tobin bronze. Bevel the crack right out to the bottom. We assume that the crack extends to the edge of the bell, so start at the top and work towards the opening. If the crack extends nearly to the edge, it is advisable to bevel out what would be the extension of crack if it had gone to the edge. Pre-heat in charcoal, heating very evenly to a good temperature. Protect the bell from draughts when heating, welding and cooling. A large tip will be essential, since large bells are usually fairly thick in section. Unless you have the bell well pre-heated, the heat of torch is likely to cause unequal expansion, so that small cracks will result. The tone of the bell when welded depends considerably upon the rod used as a filler, but Tobin bronze and a good weld usually makes no difference in the tone of bell when welded.

Easier on the back.—"I do not want to miss a copy for I am getting in the auto business and it is a great help to me. I would like to see more of it in the paper. The auto repair work is a whole lot easier on a man's back than shoeing horses. I like the work. It is interesting and there's always something different turning up to make a man use his mind."

N. L. Kimmen, Minnesota.

Successfully Welds Springs.—"The average smith and auto expert will tell you that springs cannot be welded so they will give satisfactory results. I have been welding them for eight years and the welded springs give as good service as when new.

I first upset the broken ends of the spring in order to hold the size for if you lose the size and thickness, the job is a failure. After upsetting I scarf to thin edges and weld in the usual way. Care must be taken and not get the spring too hot as proper heating is the secret of a successful job.

I must say that I am the only smith in this part of the diggin's that puts them together so they will stand and I have been so successful that I get a lot of work from surrounding counties. My charges are based according to the size of the spring."

R. J. Mooney, Tennessee.

AMERICAN BLACKSMITH AUTO & TRACTOR SHOP

VOLUME 18

APRIL, 1919

NUMBER 7

BUFFALO, N. Y., U. S. A

Established 1901. Published Monthly at the Sidway Building, Buffalo, N. Y., by the

AMERICAN BLACKSMITH COMPANY

Incorporated under New York State Laws.

WILLIAM F. WENDT, *President.*

WALTER O. BERNHARDT, *Editor.*

SUBSCRIPTION PRICE:

For \$1.00 per year, payable in advance, The American Blacksmith, Auto & Tractor Shop will be sent, postage prepaid to any postoffice in the United States. To Canada, \$1.25; to other countries, 6 shillings. Reduced rates to clubs of five or more on application.

Remittances may be made by money order, express order or checks payable to the American Blacksmith Company. We will also accept uncancelled postage stamps or currency, but for safety these should be sent by registered mail.

Subscribers should notify us at once of non-receipt of paper or change of address. In latter case, give both old and new address.

Correspondence on all smithing subjects solicited. Always give name and address, which will be omitted in publishing, if desired. Address all communications to the

"AMERICAN BLACKSMITH COMPANY"
BUFFALO N. Y

Copyright W. F. Wendt Publishing Company, 1919 "

Cable Address: "Blacksmith, Buffalo"

WATCH THE STOCK PEDDLERS

READERS:—Get the names and addresses of all persons and companies offering you speculative or doubtful stocks and securities, particularly if in exchange for your Liberty Bonds or War Savings Stamps, with copies of their "literature." Mail them promptly for investigation to the Federal Trade Commission, Washington, D. C.

Help The Victory Liberty Loan

"A JOB FOR EVERY FIGHTER"



—St. Louis Star.

HOW SOME SERVICE FLAGS MUST
LOOK TO THE RETURNING SOLDIERS

THE AMERICAN INDIAN

We welcome to our shores the natives of almost every country under the sun and eventually give them citizenship, yet deny it to the one nationality that has the best right to it—the American Indian. We take to our bosom the human refuse of Europe, Asia and Africa and try to make Americans of them, but what do we do for the fellow who was here before we were? Why, we say, he's a savage, unable to control either himself or his property, so we confine him on a reservation and employ seven thousand of the people who have robbed him of nearly everything he ever had, to see that he doesn't escape.

And why isn't he a citizen? Some wag has answered this question by saying, "because he was born here". When we hear some of these with whom we are surrounded proudly say, "Me citizen", it's pretty tough on the American Indian to say he isn't their equal. The Indian has fought with us against every foreign foe since the landing of Columbus, he bought fifty million dollars worth of Liberty Bonds and gave two million to the Red Cross, nine thousand of his race volunteered for service, yet we say he is not as good as the Italian blackhander or the Russian anarchist.

If the American Indian is still a savage, whose fault is it? He has been in our custody for four hundred years and surely in all that time he could have been civilized had proper effort been made. And, if he isn't a savage why is he treated as one?

The status of the American Indian is a living disgrace to the land of the free and the home of the brave. Some day some one will be found big enough to take up his cause and the country will then realize the injustice that is being done to him and he will be given his citizenship.

CONTENTS—APRIL, 1919

| | |
|---|-----|
| Some Welding Shop Ideas..... | 159 |
| Blacksmith Overseas | 161 |
| Gas Engine Experiences | 162 |
| Ford Light Dimmer | 163 |
| Spring Dragging of Dirt Roads..... | 164 |
| Sets of Body Irons..... | 165 |
| Electrifying the Ford | 166 |
| Bench Drill Post..... | 167 |
| Remarkable Hill Climbing Contest.. | 169 |
| Benton's Recipes | 169 |
| Shop Note Corner..... | 171 |
| Two Vise Helps, Polish Spray, Pulling Bushings, Cutting Gauge Glasses, Inexpensive Hatchet, Sheet Metal Shears, Drilling Spring Steel, Pipe Flanging Rig. | |
| Steam Driven Automobiles | 172 |
| Hydraulic Truck Hoists | 175 |
| Convoy Workshop Experiences..... | 176 |
| Electric Welding | 178 |
| When a buyer misrepresents Himself | 180 |

DON'T GIVE MONEY TO AGENTS

The American Blacksmith, Auto & Tractor Shop DOES NOT employ subscription agents. Any person representing himself as such is an imposter and should be so dealt with. Notify us immediately if anyone claiming to represent this journal calls upon you.

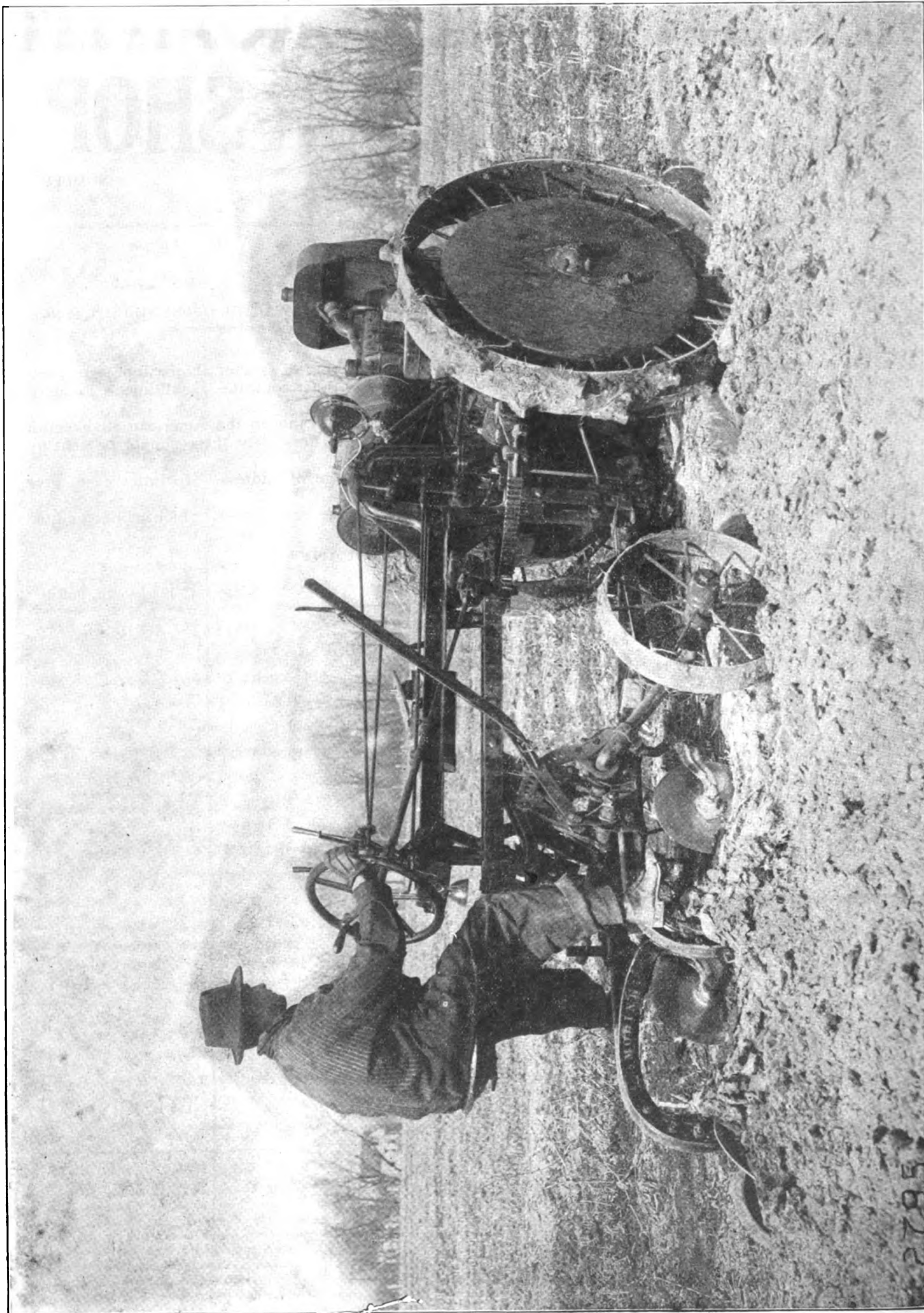

Photo by courtesy of McCormick Tractor Co.

Once the farmer starts a job of plowing with the tractor he need not stop until the job is completed. He does not have to drive the horses home for the night and spend valuable time in feeding and bedding them down. The tractor more than any other device is making life worth living on the farm, instead of the endless round of drudgery that has been the lot of the farmer in the past.

Some Welding Shop Ideas

David Baxter

THERE are many devices for use in a welding shop that may be made with little or no expense by the welder himself. Many of them are indispensable once the welder is accustomed to them. In fact it seems foolish for any welding shop to rub along without some of the many devices to be made. The apparatus shown in the accompanying pictures and drawings are a few which will save a great deal of time and money for the owner of a welding plant. They are simple and cheap to make, but strong and durable. To construct them the welder needs nothing but his cutting and welding torch in the way of machine tools. The material can just as well be second hand or junk material. Nearly all of the welders' equipment is made of metal, which is well on account of their fire proof qualities. Most of the parts for the devices illustrated were culled from the junk yard.

Compound Heater.—First let us examine the device shown in picture No. 1. This is the device for use in preheating many different kinds and sizes of jobs. It is adaptable to jobs where only a small amount of heat is necessary, or to jobs where an immense amount of heat is needed; and to an almost limitless number of different stages of preheating fire, between the two extremes. It is a manifold, so to speak, which takes fuel gas from a single unit or line and spreads it with equal pressure through six home-made jets or burners. With it the welder can preheat six different smaller jobs or one very large one. Or he can localize or concentrate the heat as he desires. The preheating flames may be directed to six different parts of a job or they may be all directed and confined to one section of the job.

To make a spreader like this it is only required to obtain a piece of old gas pipe about five inches in diameter, three feet long; six small globe valves and twelve quarter inch nipples about two inches long. First, cut six holes in one side of the five inch pipe with the cutting

torch. See drawing. The cutting may be accomplished by holding the cutting flame on the spot until it blows a hole through the pipe, then work it around in a tiny circle until the hole is large enough. Repeat the process for the six holes. Now make a hole the same way on one side at right angles to the six holes; this is for the gas inlet valve. Now cut out two heads or ends for the pipe from any handy scraps of sheet metal. These heads may be cut with the torch and any circle cutting attachment. Next is to fit the thing together. But first we must cut a baffle plate and weld it



No. 1.—THE COMPLETE GAS MANIFOLD AND PREHEATING TORCHES

to the inside of the five inch pipe. This baffle plate is merely a strip of sheet iron as wide as the inside diameter of the pipe, eight inches shorter than the length of the pipe. This plate is welded at four corners to the inside of the pipe. It is placed in such a way that the incoming gas will strike it and be forced to pass around the ends of it before reaching the outlet or spreader valves. In other words the gas can not enter the chamber and rush right out through the

nearest outlets, but must gather in the chamber and come out with equal pressure through any or all of the outlet valves.

After the baffle plate is welded in, six of the nipples are welded in the six holes previously prepared for them. This welding is done by melting a fillet of metal around each one, joining the nipple to the large pipe. When the nipples are all welded in it is well to see that none of them are obstructed before welding in the heads. A longer nipple is welded in the hole left for the gas inlet. The valves are screwed onto the nipples and the other six nipples are screwed into the valves; these nipples are for attaching the burner hose to the valves. The burners are also home made, being merely six pieces of two inch boiler flue with quarter inch gas pipe welded to them in the manner shown in the accompanying sketch. These burners give a large flaring flame if the gas is turned on full; They do much better work than the usual type of gas burner on this account. A section of hose about ten feet long connects each burner with the manifold, which admits placing the manifold far enough from the preheating job that it will not be in the way. The whole contrivance can be taken out of the way when not in use.

Welding A Particular Job.—Picture No. 2 shows the preheating device described in use on welding a job. This job, a large lard kettle or cauldron, requires particular care in preheating, as many welders have found to their sorrow. The preheating must be even and well regulated lest the kettle cracks upon cooling or even while the welding is in progress. The kettle should be almost red hot in every part. This is required on account of the shape of the casting and the thinness of the metal of which it is cast. Any part of the kettle that is not hot will not expand, nor will it contract, the same as the hot sections, therefore, a strain will be set up that will result in a crack when the kettle starts to cool; and

perhaps while the work is in progress.

Many experienced welders as well as beginners have trouble welding these kettles. But when once the requirements are understood they are simple enough. The essential feature of the process is correct preheating. The kettle must be uniformly hot all over. There must be no combination of red hot spots and cool sections; the whole kettle must be hot enough to expand to its fullest extent. This heating is handily accomplished with the device described. The burners are arranged at regular intervals around the kettle which is placed upside down as pictured. The gas pressure is turned on gradually until the whole inside of the kettle is filled with flame. The welding is not commenced until it is certain that the kettle is fully expanded: the kettle should be very hot. While heating, the entire job should be covered with some heat-resisting material such as asbestos paper. When welding, only such part of the crack as is directly under the welding flame is uncovered; only a small part of the asbestos paper is removed as the welding progresses. The picture shows about half of the kettle bare, but this is merely to show the extent of the break which was outlined with chalk to make it plain in the picture.

After the entire break is welded the whole thing should be covered with asbestos and allowed to heat several minutes before turning out the preheating flames; this to bring up any relaxation of the expansion so the job may cool and contract uniformly. The job should not be moved for several hours after covering. It should be almost cold before removing the asbestos.

The kettles are not usually more than a quarter of an inch thick and generally much less and may be welded without the customary grooving of the crack. In fact it is hard to groove the crack unless it is done with a file or grinder on account of the danger of breaking the kettle if a chisel is employed. But the welder must be careful to weld the entire thickness of the metal to make the weld hold.

A filler rod three sixteenths of an inch in diameter is plenty large enough for these cauldrons; it should be of soft, high silicon cast

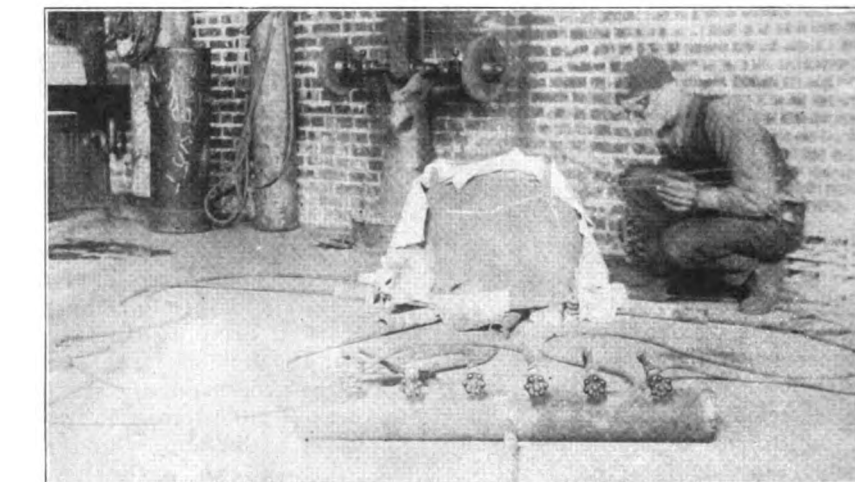

No. 2—THE PREHEATING MANIFOLD IN USE

iron. And plenty of good iron flux should be used.

Slag usually forms in the welds due to the lifeless quality of the metal caused by the kettle having been much in direct contact with fire. All of these bits of slag must be fluxed to the surface of the melting weld and picked out with the filler rod, or flirited out with the welding flame.

A medium sized tip is employed because a large one tends to burn the metal while a small one will not melt fast enough. "Pin holes" often develop, showing clearly after the job is finished. These must be melted out or else the kettle will leak. To do this the entire kettle must be reheated and each pin hole picked out with the filler rod or a skimmer.

A good flux for such work as described is powered borax. It is applied with the filler rod by dipping the melting end of it in the powder at short intervals during the welding, meanwhile keeping the welding flame moving around in tiny circles over the melting weld. This circular motion should be employed throughout the entire welding not merely while applying the flux.

To sum up briefly: to successfully weld one of these cauldrons we must have it very hot in all parts; we must weld to the bottom of all cracks; we must use plenty of flux, and a soft filler; work rapidly and cover the entire job when the welding is finished.

Two More Devices: Picture No. 3 shows two more home-made devices that are useful to the welder. The one is a special babbitt ladle; the other a gas burner. Both were made of junk material. The burner

is an old cook stove burner welded to a section of wrought iron pipe, with an arrangement for attaching a hose to the gas line. This burner is used chiefly where a slow, steady heat is desired on small jobs such as crank cases, housing, small gears, etc. It is used mainly for work done on the welding table; work that is too small to handle on the floor conveniently. With a burner like this the temperature may be regulated to almost any degree. The device can be employed in any corner of the shop according to the length of hose attached.

The home-made babbitt ladle is made of a short piece of four inch pipe with a thick piece of sheet metal welded in to form the bottom. A convenient depth for such a ladle is about six inches. This allows the welder to melt several pounds of babbitt or aluminum. After the bottom is welded in, lips are formed by heating the rim with the torch and shaping with a ball peen hammer. Then the bowl is welded to a wrought iron handle. This ladle has a flat bottom which is an advantage over the usual round bottom type that, because it may be set down anywhere without danger of overturning and spilling its contents. A babbitt ladle is handy in many ways around a welding shop. One such use is to catch the metal when babbitt bearings are being melted out of welding jobs. It is a paying proposition to save all such babbitt.

Empty carbide cans are a source of vexation in the average shop, usually being piled around in the yard, where they are an untidy sight. The enterprising welder with some inventive ability can readily make use of quite a number

of these cans. Being moisture proof they form ideal receptacles for any kind of material that should be kept dry, such as flux powders. They may also be used as containers for saving small shots of welder metal, bolts, clippings, punchings, etc., all of which have a marketable value if saved in quantities. Some welders use the cans to re-ship small welded castings. By packing small fragile castings in excelsior or straw in the cans they may be shipped to the customer with a certainty of not being broken. The shape and construction of the can is such that it will not be crushed in the ordinary handling of freight. And, too, they weigh but little more than a stout wooden crate.

Handy tool-racks can be made out of empty carbide cans. And their moisture proof construction makes them an ideal storage place for filler rods, especially aluminum filler rods which are soon covered with oxide if allowed to remain in an open rack. A good filler rack is illustrated in the accompanying sketch. This rack is a tier of empty carbide cans fastened to a wooden frame work. The lid of each can should be labeled with the kind and quality of filler or other material the can contains. The lids may be fastened to the rack with a wire or chain, but this is not necessary if the welder is careful to replace the lid each time he takes out any material. By keeping the cans

ter welds. Aluminum welds may be spoiled or at least troublesome by the use of filler that has been exposed to the direct action of moist

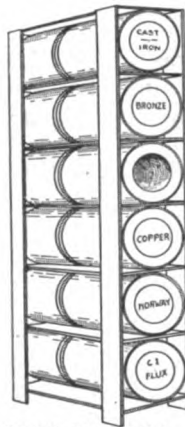

RACK MADE OF EMPTY CARBIDE CANS

air for several weeks; and the welder will wonder what causes the difficulty. It is well not to keep on hand a large amount of aluminum filler on this account. Other kinds of filler metal are not so particular but at the same time it is better to not allow them to gather rust or dirty grease. Any dirt or rust is bound to be a detriment to the perfect weld. A storage rack made of carbide cans, like the one shown in the drawing, ef-

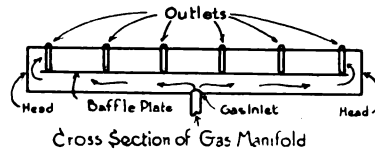

Cross Section of Gas Manifold

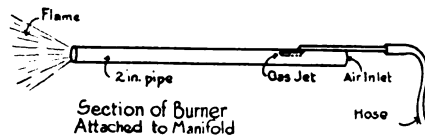

Section of Burner Attached to Manifold

CONSTRUCTION DETAILS OF PRE-HEATING TORCH

fectually prevents filler rods from deterioration. It occupies but little floor space and is easily made by any mechanic. It is just the right size to fit behind the door. Build one today and see how it will save, besides getting rid of several empty cans.

The foregoing suggestions should furnish the ingenious welder with ideas for making many other handy "riggings" for the shop. And constructing them is good to fill in slack time and "rainy days".

Where oil will not act as a cooling agent on a drill when working in hard metals, turpentine used instead will permit the drill to take hold and retain its temper.

Iron or steel may be made rust-proof by boiling in a mixture made of one gallon of water to which is added four ounces of phosphoric acid and one ounce of iron filings.

THE BLACKSMITH OVERSEAS

Capt. John B. Woods

The war being one of machinery, with several hundred thousands of horses and mules thrown in for good measure, the all round blacksmith was a man of peculiar and highly appreciated value. Whether he rated as a horseshoer or a highly specialized iron burner and oxy-welder he was eagerly sought after by every company commander and stolen from whatever outfit he belonged to by whoever could get him at every opportunity and with a clear conscience.

When we first reached the other side, in the early Fall of 1917, the writer was with a lumber jack regiment. Our first location was in Brittany, where we found fine pine timber to be cut, but not much of anything in the line of equipment with which to cut it. Our mill came in piecemeal, with many missing parts, and when our horses arrived they were shoeless and also unsupplied with any harness except artillery type, which was utterly unfit for logging.

But in spite of all other troubles we did have two of the best blacksmiths who ever burned a bolt. And we rigged them a rustic shop at one side of the mill site, and while other folks were worrying about a great many tasks in construction and logging, they plugged away at their trade. The frame of their studio was round poles. The walls and roof were of canvas, a combination of old wagon sheets, tarpaulins, and an officer's bedroll cover. A light, portable forge sufficed for early needs, supplemented by sketchy equipment of shoeing and iron working tools, taps, dies and the like. For a water barrel they used a G. I. can, thereby intruding upon the sacred precincts of the Quartermaster Corps and stealing one of their most valuable items of camp equipment.

One of the men went to work shoeing the horses, and he had a fine job, for they had been barefoot throughout the Summer and were long-toed and soft of foot. Between whiles he made logging grab-hooks for the team boss and fitted chains with hooks and rings so that they could go to work in the woods. The other man, who was boss blacksmith, worked for the mill erectors, supplying bolts for the building and making many a missing part out of raw iron or steel. Among



No. 3—THE GAS BURNER AND LADLE, BOTH CONVENIENT ACCESSORIES IN THE WELDING SHOP

closed all moisture and gas are prevented from attacking the fillers and powders.

Clean dry fillers mean cleaner, bet-

his most worthy creations were four lumber buggies, a pair of Michigan big wheels, and a steel pinion for the feed works, which items show something of his versatility. But of course this took time, and the mill began to run early in the game, so that there was much routine work to be done.

After lumber began to appear from the saws we remodeled the shops, using the same frame, but covering its crooked bones with bark-edged strip and thin board



EARLY SMITH SHOP OF THE A. E. F.

pieces that were waste otherwise. In this manner a fairly good place was given them for work.

The line between blacksmiths and machinists was not finely drawn in France, for often the one must needs act as the other. In brief, there was work of many kinds to be done, and he who was able was expected to do it. Often a machinist would put in his time shoeing horses on a job where no machine tools were available or required. And I have seen a man turn from shaping a horse shoe and take down an auto-truck engine and grind the valves, putting it back together again and giving it a tryout after the thorough overhauling.

One the cleverest pieces of work, although of no great moment except as typifying the versatility of the breed was done of a Sunday afternoon by a Yankee blacksmith in a rest camp. A new graphophone had been received without any crank, and there were hundreds of men in the Y. M. C. A. wishing to play over the records. So this chap, who was rated as a horse-shoer, hunted up a scrap of round iron, took it down to a French machine shop where work was being done on shells for the army, and in a short time fashioned a very neat and serviceable crank for the machine.

Some Gas Engine Experiences

W. A. Reagan

WHEN I was a "kid" about 15 years old, gas engines were something of a curiosity and I remember that we used to "sing" a little jingle that ran something like,—

Gasoline! Gasoline!
First we put you in a tank,
Then we turn a little crank.
Chug-a-chug, chug-a-chug.
Gasoline!

But coming down to prosy facts, I will recount some of the interesting experiences of my eight years' career as a nurse and physician to peevish and ailing gas engines in the hope that my experiences will "serve as a lesson to others."

I am not going to tire anyone with a description of the "technology", or whatever it is you call it, of gas engines. The manufacturer goes to a lot of trouble to do that in his catalogue and instruction books so any such description from me would be merely an attempt to improve the lily by painting it, after a way of speaking.

We all know, or should know that there are three vitally important things to consider in your deal-



A LATER DEVELOPMENT OF BOARD WASTE AND SLABS

ings with all internal combustion engines:

- 1—Timing.
- 2—(Gasoline (or other fuel).
- 3—Ignition (or "firing").

If there are no broken or defective parts and these three items are each in their proper places and operating positions the engine will run.

I well remember my first experience with a balky engine. When I was at home on the farm with "dad", we used to help the neighbors with their threshing and each in turn helped us. Everything

went along fine the first day. The second day the "darn thing" (it sounded something like that) began to balk and finally died. Of course everyone gathered around the engine and ventured a diagnosis of the case as well as prescribe a course of treatment and dope out a prognosis as to the effect of their individual treatments. Of course the best they could do was to "guess" at the trouble and it is these guesses that are too often followed and mostly with no result. The man who owned the rig knew little more about it than anyone else in the crowd and his ill directed experiments were unavail-

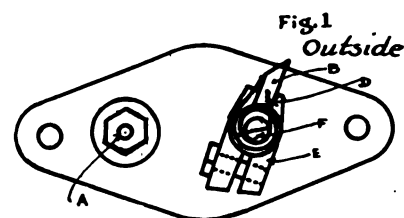

ing. He tinkered around with the engine until evening when we adjourned for supper. After supper he took a lantern and went after it again and then I horned in on the session. (as I was one of the "kids" I had kept in the background during the day.) I began hunting around to see if I could locate anything that was broken or loose and finally on coming to the igniter I found that the spring holding the igniter hammer and rotating electrode in contact had slipped about an eighth of an inch. I told the owner; he fixed it and the engine started on a turn.

I do not wish to exalt myself for this job but merely to show that the owner had not studied the principles of his engine to locate a trouble that one ignorant of the trouble located through curiosity. I have since found that a great deal of the difficulty experienced with gas engines is at the igniter and especially if the engine has seen considerable service.

Just a short time ago I was called to repair an engine that had been "dead" for over a day. The owner had tried all the tricks of his limited mechanical knowledge without results. It was the same

fault that I have just mentioned and it brings to mind the saying: "the smaller the trouble the harder to find."

Most all engines are now made with make and break spark with the igniter or trip hammer working loose on the moving electrode like a bearing and connected to the electrode shaft by a spring which, in most cases, is conical in shape. When the oil gums on the electrode or it becomes dry for lack of oil, the hammer will move but the electrode will remain standing still.

The spring D in Figs. 1 and 3 caused the trouble in this and many other cases and a screw driver and pair of pliers generally effect a cure, by taking up the spring so that the hammer B in Fig. A can easily be snapped with the thumb but still giving it a nice drawing tension.

I have also seen engines repaired with springs that were too light or too soft or which were not strong enough to turn the electrode with the "snappy" break required.

Another fault in the ignition or firing, and one that could be, and in some makes is prevented, is caused by the wear that soon makes itself shown in the moving electrode for lack of an outboard bearing on the same. I would advise and do myself, make and fit such a bearing if at all possible when I am repairing engines that suffer from this fault. An engine with play at this point not only fires poorly but loses compression and sends out sparks of burning carbon.

A good remedy for worn electrode bearings that I have used with satisfactory results consists

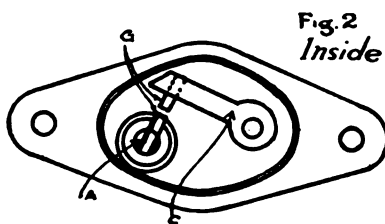

in removing the igniter and boring out the bearing for the moving electrode shaft about 1-8 or 3-16 of an inch oversize, if the stock permits, and putting in a snug fitting bushing, making a snug fit for a new shaft or turn down the old one true and fit the bushing accordingly. Bronze makes a fine bush-

ing for this purpose and should be used when available but good steel will answer in its absence.

Another common source of trouble is the firing points G in Figure 2. If these points are burned or corroded too much they will make a poor contact and a weak spark will be the result. In such cases the points should be filed down smooth with a fine file or with emery cloth. After this is done be sure that the points are making a good contact when snapped or there will be no spark. If the points are hopelessly worn out and new ones are not immediately available a common wire nail will answer the purpose temporarily. The old points on most igniters can be removed with a very small punch as they are put in with a driving fit. The best plan is to get new points of good tungsten or platinum alloy. Obtain them from the manufacturer if possible to insure a ready fit without alteration. These points retail for about fifty cents each.

I have come across quite a few engines that were not giving the power expected or required of them. Often this trouble is caused by incorrect timing of the spark and the engine not being properly adjusted to admit the gas or let out the exhaust at the proper cycle of the engine's operation. Most engines are made with a screw that regulates the push rod that works the igniter hammer. This should be set so as to "snap" or fire about seven degrees before dead center when the engine is running at working speed and when the spark is fully retarded (providing your engine has a spark throttle lever) it should fire just a fraction after the engine has reached dead center to prevent backfiring and the possibilities of accidents. If there is no arrangement for retarding the spark its absence can be partly overcome by holding open the intake valve with one hand or by having someone else do it if it is on a large engine and give the engine a good start before closing it for compression.

The foregoing are only a few of the many troublesome and interesting things that I have come across when called out to repair some recalcitrant engine and if anyone else will study the main principles of an engine and take things a little easy at first there is no doubt

of his ability to "ring up" some of the cash spent by farmers in his locality on gas engine repairs.

If I can be of any service to any shop owner doing work in this line I will be glad of the opportunity of

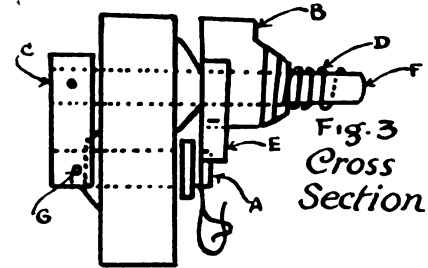

answering any such inquiries through these columns to the extent of my ability. I have learned much in this manner so the little that I can give will be given cheerfully.

LIGHT DIMMER FOR FORDS

Take a coil from an ordinary door-bell and mount on dash with one end of the coil wire leading to the small two point switch and attach the other end of the coil wire to the wire running to the head-

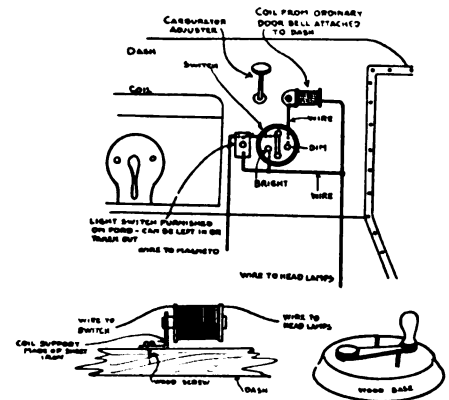

EASILY MADE LIGHT DIMMER FOR FORDS

lights. A wire should run from the magneto to the center point of the switch and a wire should run from the other point on the switch to the headlamp wire.

To dim the lights place switch lever on the point connected with the coil. This places the coil in the circuit and the resulting resistance serves to dim the lights. Placing the switch lever on the other point cuts out the resistance and the lights shine at full power.

C. C. Spreen.

How Dirt Roads Should be Handled This Spring to Put Them in the Best Condition

It can be truthfully said that drainage is the chief essential in putting earth roads into proper condition. An old Scotchman, an expert road builder, aptly said that the three requirements of good earth roads are, drainage more drainage, and still more drainage. Roads must not only have good surface drainage but must also have good under-drainage. Sur-

face drainage is secured by proper grading, adequate side ditches, and by keeping the crown of the road properly dragged. Stretches of road that do not dry out quickly must be under-drained by tile.

The drag must be used after each rain, if the best results are to be secured. Don't go on the road while too muddy, let it dry out slightly; it should be wet enough, however, so it will not crumble, but smear. When properly used, the

drag brings a thin layer of earth toward the center of the road which is rolled and packed between wet periods. If too much crown is secured by dragging, the angle of the drag should be reversed.

Getting the earth roads graded, ditches open, well-drained, and properly crowned by dragging is about all that can be done until the people are ready to surface the road with gravel, broken stone or some other surfacing material.

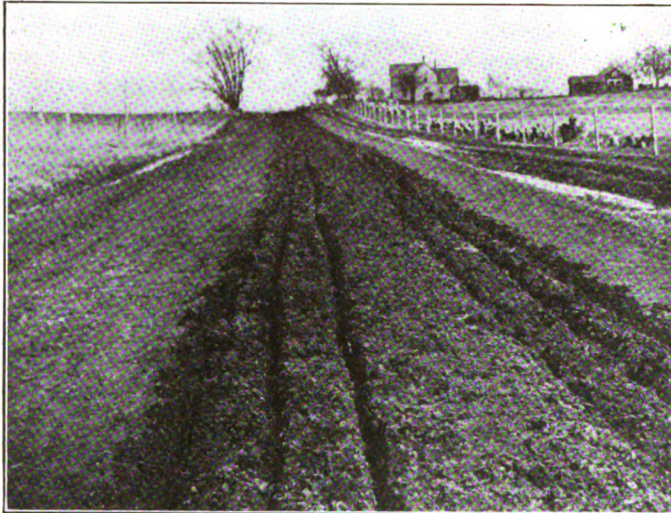

PLAIN EARTH WEARS INTO RUTS, WHICH MAKE DUST IN DRY WEATHER AND MUD IN WET



WHEN THE SPLIT-LOG DRAG IS USED AS IT IS BEING USED ON THIS ROAD, THE SURFACE BECOMES RUTLESS AND HARD. NOTE THE STONE DRAGGED TO THE CENTER

WHY WAR TRUCKS WON'T BE SOLD

"Trucks used for the transportation of men and materials during the war will not find their way back into the market," says a former member of the 102d Engineers recently returned from France.

"There are two reasons why this is so," he explained. "One is that the transportation problem is equally as difficult now as it was when the war was reaching its climax. The other is that the trucks have been subjected to such hard usage that when discarded from military service they are junk.

"When units are broken up and returned for muster out, motor transports are turned over to a base motor depot. Those that can be repaired are overhauled and kept in service; but many trucks are scrapped on the ground without even being taken to a salvage dump.

"These worn-out trucks will

have to be replaced by new trucks and it is doubtful if the number of trucks now contracted for will be sufficient to take care of present needs.

"The railroad system of France, even including the temporary military railways, is hopelessly inadequate, and motor transports are overloaded and driven at excessive rates of speed over roads that have been worn out by traffic night and day or ruined by bombardment.

"The cessation of hostilities has not relieved transportation difficulties. Troops must be fed and clothed, and the large movements of troops now taking place in France add to rather than lessen the demand for transportation. The feeding of the Central Empires also adds greatly to the burden of transportation for them as well as the Allies are short of transportation.

"Then the return of the refugees to the devastated regions where

railroads and nearly all roads have been badly damaged by shell fire, requires an enormous amount of motor transportation. These people require supplies of all kinds, in addition to clothing and food, with which to rebuild or restore their ruined property.

"Factories, stores, homes and even farms must be rebuilt, and until the entire war ruined area is restored there will be no lessening of the tremendous demand for trucks."

LOCKING SCREWS

It frequently happens that a screw is so located that a lock nut, cotter-pin or the usual devices cannot be used to hold it. By cutting a short length of iron wire, bending it a little and then, after the screw has been sunk under the surface, drive the wire in so that it lies in the slot, the screw will be firmly held in place.

Ready-Made Body Irons in Sets Materially Reduce Costs

"This is an age of specialists" is a saying as apt as it is tiresome. nevertheless we all admit that the specialist in some particular line is able to produce better work for less money than the man who takes a crack at anything.

This situation has long existed in the blacksmithing and wagonmaking business where the wagon maker spent hours and hours of valuable time thumping out more or less accurately fitting body irons and then had to drill and thread them in the bargain.

Happily the specialist has taken up the subject and the shop owner is now able to get complete sets of malleable irons at a nominal price, that fit accurately and come ready to install.

We reproduce above a few examples of such body irons as applied to light automobile bodies but similar irons are obtainable for other types of vehicle bodies, the cost being much less than the labor cost of making them by hand in the shop, besides being obtainable in all standard sizes. It is also possible for the wagonmaker to buy these irons without buying a full set. Home made irons have been the cause of much lost profit on body obs that the new system eliminates.

As an example of the number of pieces required that the smith would have to make (if he could make some of them), the full panel body with curved sides and end is selected as an example. A complete set of irons for such a body would require the following:—door lock; door hinges, upper and middle, four pieces; door hinges, lower, two pieces; rear post inside body braces, one pair; side post, inside body braces, six pieces; roof rail corner irons, eight pieces; front arch stay braces, one pair; rear post, top rail corner irons, one pair; top rail corner plates, front, two pieces; seat and body corner irons, two pieces; jointed lazy back irons, one pair; foot board plates, one set; body and chassis connections six pieces.



Seven and one half miles an hour was the dizzy speed attained by the winning machine in the first automobile race.

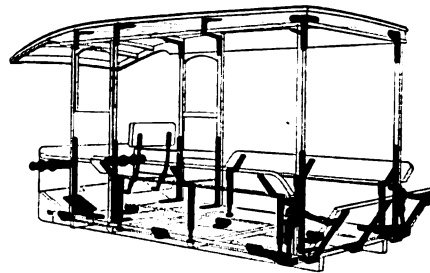

SIX POST BODY WITH FLARE BOARDS

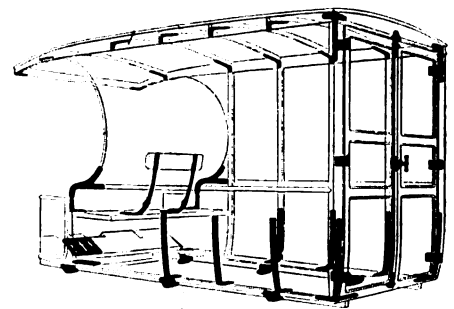

FULL PANEL BODY, CURVED SIDES AND ENDS

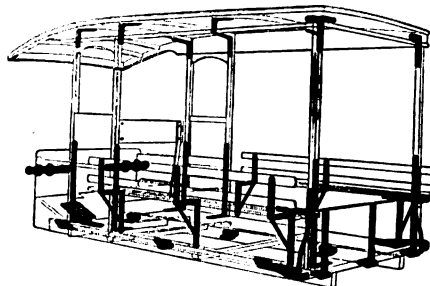

FOUR POST FLARE BOARD BODY

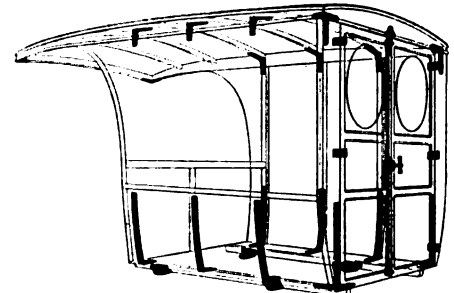

FULL PANEL BODY, CURVED SIDES

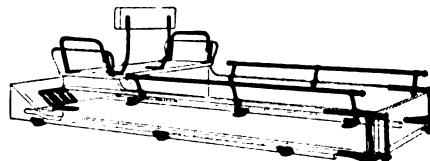

OPEN RAIL BODY

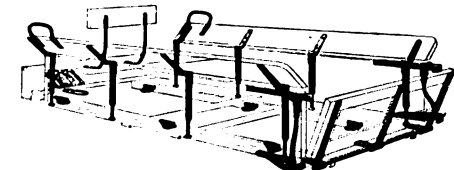

OPEN FLARE BOARD BODY

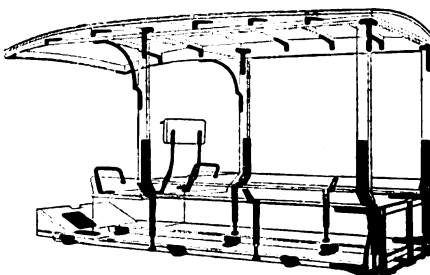

SIX POST BODY WITH SIDE EXTENSIONS

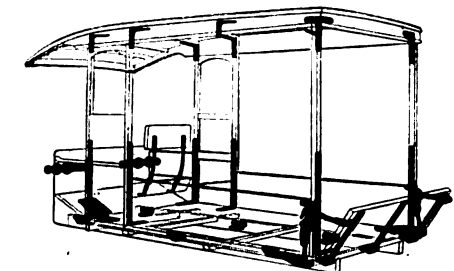

SIX POST BODY

Illustrations by courtesy of the Eberhard Mfg. Co., Cleveland.

WHEN BABBITTING

Remember when you go to babbitting ojournal boxes that the best temperature or pouring babbitt metal is 360 deg. C., with a permissible variation of 10 deg. each way. Old babbitt that is coarse grained and brittle may be improved by heating to this temperature and cooling, then heating again for pouring.

REASON FOR ACCESSIBILITY

Another important point in selecting an engine is the location of the magneto, carbureter, valves, and other parts which require attention. To have to remove the magneto, for instance, to see the circuit-breaker points, let alone file and adjust them, not only is troublesome, but it takes time, and time is money. Also see to it that it would not be an unreasonable job to pull the pistons or remove the cylinders.

Electrifying the Ford

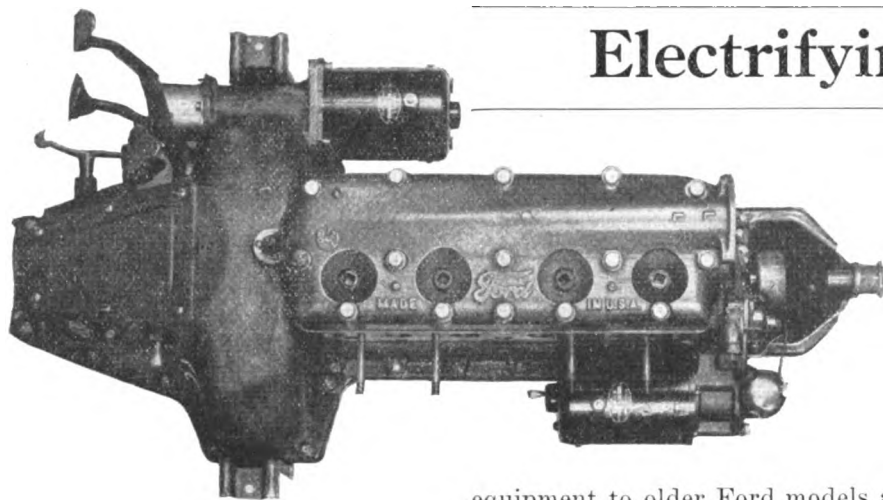

The story goes that the Ford company had contracted for a large number of electric starters and generators that were to be built into the famous "one man" tanks and had a large number of these equipments on hand when the armistice was signed.

Whether or not this is the case, the Ford company has definitely put out a fully electrically equipped model at an additional charge of \$75, however, for the time being this equipment will only be supplied on the closed sedan and cabriolet models although it is possible that roadsters and touring cars will be thus equipped at a later date.

It is not possible to apply this

equipment to older Ford models as the illustrations clearly show the difference in form of the castings necessary for the "built in" equipment.

This system is of the two unit type, having a separate generator and starting motor. The generator is gear driven from the timer gears. It is of standard six volt capacity and is supplemented by an 80 ampere hour storage battery that is carried on the left running board of the car.

The starting unit is equipped with Bendix drive that engages gear teeth cut on the rim of the flywheel. A suitable instrument board to accommodate the coil switch, ammeter, primer, etc., is provided for these electrically equipped models

NEW LUGGAGE CARRIER FOR THE AUTO

The folding luggage carrier for the auto is the latest thing along its line to make its appearance. This holder is a collapsible arrangement which clamps to the outer edge of the runningboard of the car, the operation of attaching or detaching it taking but a moment. Its collapsible feature makes it possible for the motorist to lengthen it as much as desired, its range being from six inches to eight feet, the length of the average runningboard being about five and a half feet.

There are three strong steel uprights to this device at the lower end of each of which is a steel clamp, the three clamps holding the carrier to the runningboard. The collapsible part of the feature works like a folding office-telephone holder, and to make the holder any desired length the motorist simply fastens one of the end clamps and pulls the holder out as far as desired, fastening the other two clamps at the proper points. With the holder erected it is an easy matter for the motorist to arrange the things to be taken on the camping jaunt, outing trip,

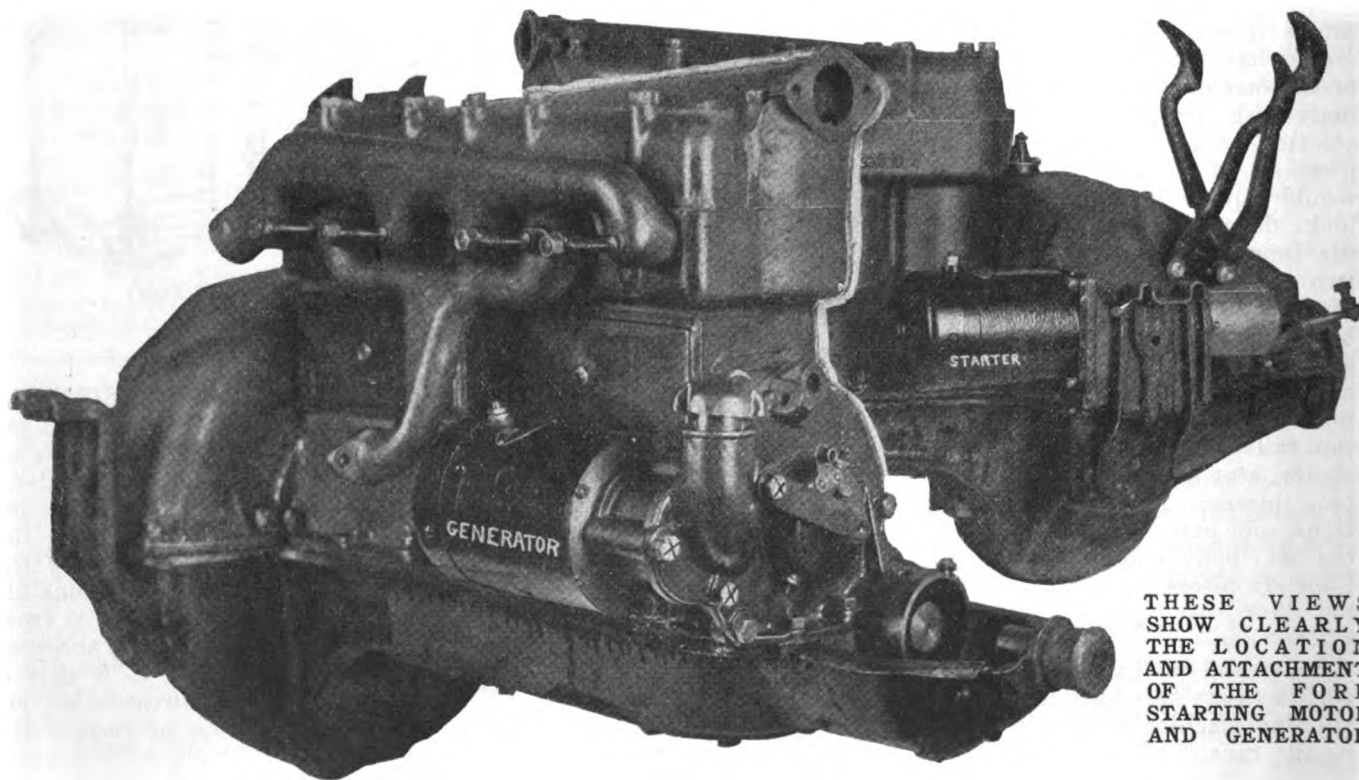

THESE VIEWS SHOW CLEARLY THE LOCATION AND ATTACHMENT OF THE FORD STARTING MOTOR AND GENERATOR

etc., upon the runningboard between it and the side of the car.

This luggage carrier is seventeen inches in height when drawn out to the length of the average runningboard, and it weighs about nine pounds. When not in use it

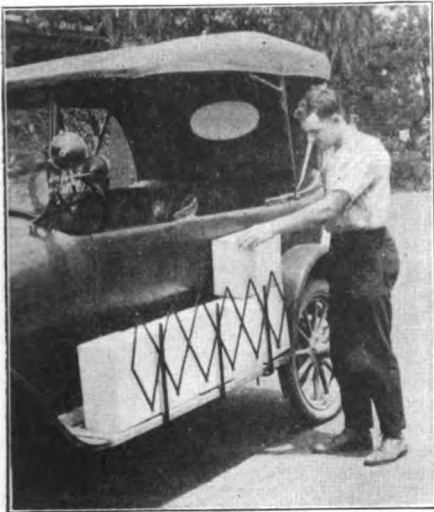

REMOVABLE LUGGAGE CARRIER FOR THE RUNNING BOARD

may be folded and placed beneath the seat or in the tool box of the machine. It fits any car and may be enameled to harmonize with the color of any machine. — Albert Marple.

SPRING ADJUSTMENT

Too stiff springs on the main inlet or fuel admission valves of the engine prevent the valve from opening to the amount for which it has been designed. The charge of mixture is throttled on the suction stroke, with bad running as a result. Such springs can be weakened slightly, but care must be taken not to get them too weak, otherwise the valve will clatter and bounce, allowing some of the charge to be forced back past the valve on the compression stroke. In adjusting these springs, run the engine at its highest speed, with the spring either closed together or else a small amount cut off until it will just operate without clattering. It will then act satisfactorily at any of the lower speeds, and will give the maximum opening. This, of course, applies only to these engines in which the inlet valve is operated by the suction of the piston.

ALL AROUND BENCH DRILL POST

For an all around handy home-made bench drill post it will be hard to beat the affair shown in the accompanying sketch. It was designed and made by the writer to provide a means of using the breast drill, carpenter's brace, or ratchet drill.

The first and most attractive feature of the rig is the means used to make it possible to use the drill post at any part of the long bench. This is accomplished by cutting numerous square holes and corresponding key-ways in a long length 2½-inch x 7-8 inch bar iron and setting this into a plank of the bench flush with its top, as shown at A in drawing. The next good point is the ease with which the drill post can be raised and lowered to suit the work being drilled. A tapered wedge key shown at B provides the means. A blow of a hand hammer tightens the wedge and holds the post, and when desired to raise or lower, all that is needed to release the key is a pry with a small pinch bar.

in and out of the vertical post by releasing the clamp at the split end as shown at C; this makes it easy to locate the drill to suit the work. By making this arm of round stock it permits the drill to be used at any angle, for the arm is able to revolve in a complete circle. The feed screw is made of a good grade machine steel bolt, the tip being conical and hardened and a hand wheel put on to make it easy to

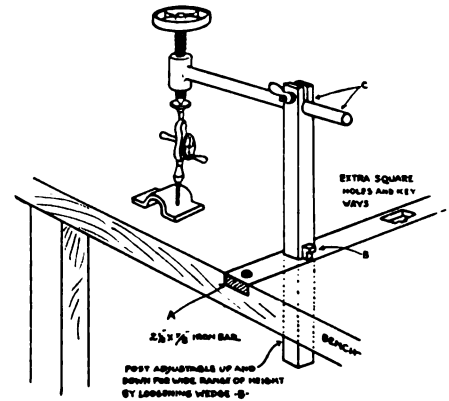

turn. By putting a countersunk center in the breast plate of the breast drill and carpenter's brace it makes them easily adaptable to this post.

It takes mighty careful driving and non-skidding tires to keep in the straight and narrow road these days, with so many roads pointed out as the main drag.

The horizontal arm can be slid

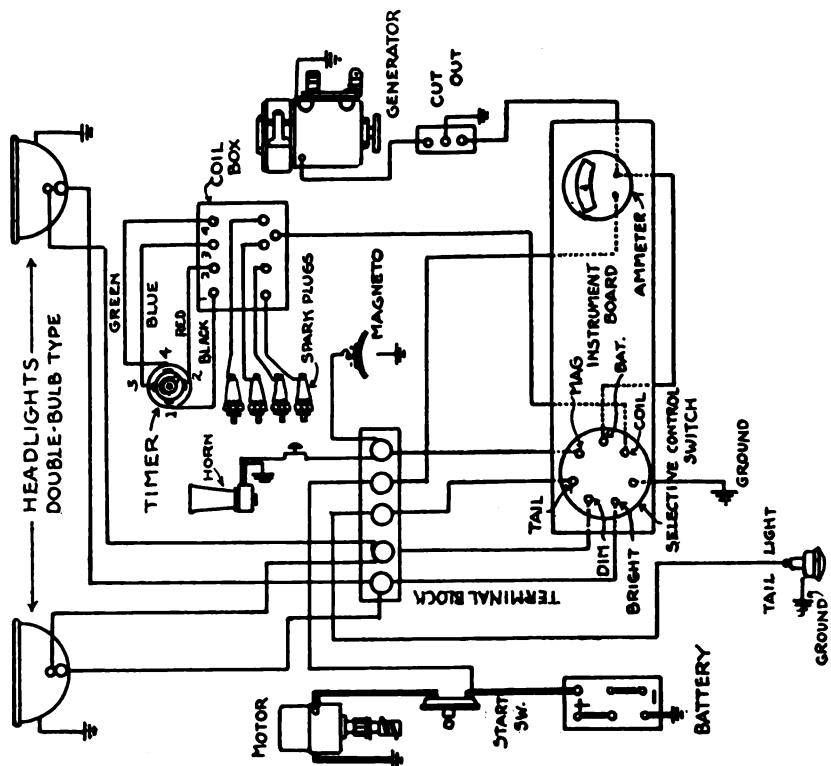

WIRING DIAGRAM OF THE FULL ELECTRICALLY EQUIPPED FORD

REV. GABE TUCKER'S REMARKS

You may notch it on de palin's as a mighty resky thing

To make yo' judgment by de clo'es dat kivers up a man;
Fo' I ha'dly need to tell yo' how yo' often come across

A fifty-dollar saddle on a twenty-dollar hoss;

An' wu'kin in de low-grounds, you dis-kiver, as yo' go,

Dat de fines' shuck may hide de meanes' nubbin in a row.

I think a man has got a mighty slender show fo' heben

Dat holds on to his piety but one day out o' seben;

Dat talks about de sinners wid a heap o' solemn chat,

An nebber draps a nickel in de mission-ary hat;

Dat's foremost in de meetin'—house fo' raisin' all de chunes,

But lays aside his 'ligion wid his Sunday pantaloons.

I nebber jedge o' people dat I meets along de way

By the places whar dey come fum an' de houses whar dey stay;

Fo' de bantam chicken's awful fond o' roostin pretty high,

An' de turkey-buzzard sails above de eagle in de sky;

Dey ketches little minners in de middle ob de sea,

An yo' finds de smalles' 'possum up de bigges' kind o' tree.

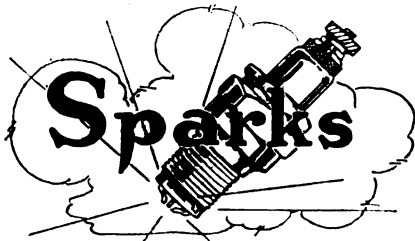

With no more whisky being distilled the grain grower can still make a rye face.

If a man is careless in his attire someone will start a story that he never takes a bath. And if he keeps himself well dressed and immaculate someone will start the story that he wears a corset.

If money talks how can we say that talk is cheap?

None is so blind as he who refuses to see through other people.

Sometimes a fellow has a pocketful of recommendations from employers who wished to get rid of him.

All men have a vein of sentiment but sometimes it's all in vain.

When the tax assessor comes in at the door truth flies out of the window.

The man who pays \$1.25 for his lunch downtown every day is the man who is usually bawling his wife out about the size of the grocery bills.

Even when a woman has been married four times she expects you to pretend to use force the first time you try to kiss her.

They tell us that the average man has a vocabulary of about 1,600 words. The trouble is that he uses the same word about 160 times when he is talking to you.

A lot of married men are going to miss the saloons when they close.

We know as well as you that you can't unscramble an omelet. But we do wish

someone would break the corner on eggs.

You never miss the water till the well runs dry and some fellows don't miss it even then.

The fact that a man has been a shipping clerk all his life doesn't necessarily qualify him for the navy.

What has become of the old fashioned newspaper beauty contest in which the homeliest girl in the county won the prize?

The man who is the architect of his own fortunes doesn't limit his plans and specifications to castles in the air.

Things are not always what they seem. Frininstance the legislature that passes bad bills isn't necessarily made up of counterfeiters.

Don't give them a chance to class your voice with the unnecessary noises.

Maybe the dear girls wear clocks on their stockings because they think they are striking.

Many a man's worst fault is drawing attention to ours.

Next year the summer resorts will be watering places.

Before she gets him she is always talking about his worth. After she gets him she is always talking about his worthlessness.

You never can tell. Burning kisses have prepared many a man for a roast.

Beauty is only skin deep and from a homely person's point of view that's the beauty of it.

We would hate to be like some people and feel so holy that we would refer to the sinners as "They" and refer to the saints as "We."

With the whole country going dry what will become of the umbrella and raincoat people?

Even the man who insists on buying his clothes made to order will buy ready-made experience.

The meanest kind of a Tightwad is one who will cheerfully spend ten dollars on

some other woman when he wouldn't spend a dime on his own wife.

The dog in the manger ought to be curtailed.

None are so blind that they can't see the faults of their friends.

It costs the average man more than a dentist's bill to cut his wisdom teeth.

You never can tell. A new broom sweeps clean, but old friends are best.

Two souls with but a single thought demonstrates that the single thought is to double up.

The marriage ceremony does the trick of transforming many a fellow from his sweetheart's lover into his wife's husband.

Nothing is so bad that it couldn't be worse. If we can pay the butcher and the baker, the candlestick-maker doesn't bother us.

When a steer gets the mouth disease you have to kill it. But when a man gets the mouth disease, the low protects the darn pest.

Women are always defending other women and claiming they are better than men. But you may have noticed that when a woman has a furnished room for rent she always stipulates: "For Men Only."

Don't holler because you are not getting what you want. Be thankful you are not getting what you do not want.

A man won't wear a hat unless other men are wearing one just like it. A woman won't wear a hat if she see another woman wearing one just like it.

You never can tell. Many a chicken fancier operates principally on Main street.

Death loves a shining mark; life is satisfied with an easy one.

Riches take unto themselves wings, but poverty wears the spurs.

A man never makes a mistake in accepting advice. It's using it that counts.

Don't be too easy. Many a man who bows to the inevitable is a victim of mistaken identity.

Many a fellow who has no music in his soul can play on our sympathies.

Look before you leap. A man must be mighty sure footed to fall in love and land on his feet.

Even the fellow who can't make up his own mind can marry a woman who can do it for him.

The nearest combination of business and pleasure is to go about your pleasure as though you meant business.

It it's true that every man has his price, a lot of them ought to be marked down below cost.

A man is never too old to learn not to marry a girl young enough to be his granddaughter.

The fellow who is in love with himself does not necessarily prove that all the world loves a lover.

Many churchgoers let the collection plate take care of the pennies so the dollars can take care of themselves.

Salesmanship is a curious thing. A canvasser can make a sale where a sailor can't.

A man who makes his mark in the world expects everybody else to toe it.

After all the world is full of poetry and it isn't in the waste basket either.

It may be more blessed to give than to receive but the average man is satisfied to hold his own.

PAST AND PRESENT

A REMARKABLE HILL CLIMBING CONTEST

Albert Marple

An event, which was without doubt the most spectacular and wonderful motorcycle hill climbing event ever held in this country, and probably the world, took place recently at Capistrano, California. This contest was filled to the brim with thrills which kept the 15,000 spectators "on their toes" every



HOW THE WHEELS DUG INTO THE GROUND UNTIL RIDER AND CYCLE WENT OVER BACKWARD

minute of the time, and the records achieved were tributes to the wonderful mechanical perfection and staying power of the modern two-wheeled chug wagon.

The hill climbing course on Mt. Capistrano is about 500 feet in length and the grade ranges from 15 to 75 per cent. At the steepest point, which is close to the top, the hill is so steep that it is impossible for any vehicle to climb it, the contest consisting of seeing which contestant can drive his machine the greatest distance up the mountainside without having to dismount or falling over backwards. Competition was particularly keen between the drivers themselves, and all kinds of contrivances were put into use to combat the terrific demands of the rough mountainside. It was a gruelling contest on all concerned—machines, riders and tires, for each mount was called upon to give its utmost in power and endurance.

In the main event sixteen drivers faced the starter and each was sent away with a rousing cheer. Up the grade the two-wheelers shot, their exhausts roaring like a battery of gatling guns. Each rider opened the throttle wide and the rear wheels of the machines chewed tenaciously into the ground, for when they began to battle with from 40 to 60 per cent, grades it was largely a question of which

one could secure the most effective traction, as well as the ability of the driver to keep his machine pointed straight up the hill. Up and up each machine fought its way, sending back volley after volley of earth as the cleated wheels dug into the ground. One by one the machines came to their fate a greater or lesser distance up the great mountainside. So far did all the motors climb up the mountainside that in every instance, before the motor was stopped, the rear wheels, rather than send the bus farther up the hill, would dig into the earth, in some instances the rear wheel settling until the crank case was resting upon the ground and the front wheel was raised a foot or so in the air.

One of the startling creations to make its appearance for the first time at this meet, was the tractor tread for the rear wheel. This consisted of an iron band run around the outside of the rear tire and held in place by clamps which ran around the rim. Extending outward from this band at given points around the wheel were cleats from one to three inches in length, which dug into the earth and drove the car ahead as the wheel spun around. It was this tread alone that enabled one driver

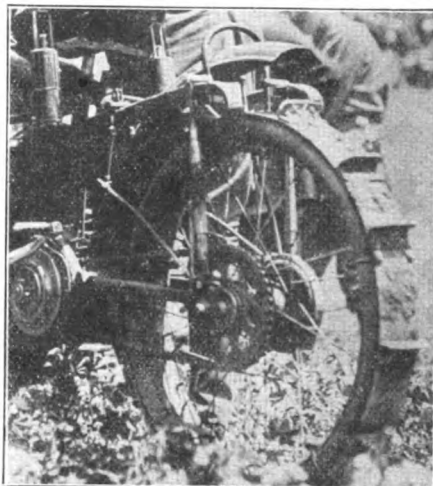

SPECIAL RIM MADE FOR CLIMBING THE STEEP GRADE

to ascend 368 feet up the mountain, where the rear wheels of the car dug such a deep hole and the hillside was so steep that both the machine and its rider fell backward down the hill. At the close of the contest the upper part of this hill was covered with holes dug by the powerfully-driven rear wheels of the various machines.

Benton's Recipes

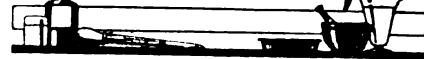

A Rust Preventive.—To keep iron goods of any kind, and especially those parts of machines which are made of steel or iron, from rusting, take $\frac{1}{2}$ oz. of powdered camphor, and melt it before the fire in 1 lb. of good lard. To give it a dark color, add as much fine black lead as is necessary to produce the desired effect. Clean the iron work, and smear it over with this preparation. After this it should be allowed to remain untouched for 24 hours, when the grease should be removed by wiping the iron work with a soft cloth.

To Turn Very Hard Iron and Steel.—Use a drip can for the tool with the following solution; petroleum, 2 gallons; turpentine, 1 gallon, and 2 ounces of camphor.

Paste for Hardening High-Speed Steel.—The hardening paste made according to the following receipt has been used on high-speed steel with success, enabling it to be hardened by heating in an ordinary gas oven, and thus making unnecessary the very high heat usually called for in hardening such steels. Mix 2 pounds rye meal; 1 pound common salt; $\frac{1}{4}$ pound pulverized borax; $\frac{1}{4}$ pound pulverized charcoal; 1-3 pint (or $\frac{1}{2}$ pound) liquid cyanide of potassium; $\frac{1}{2}$ gill or 2 ounces of water glass (silicate of soda); and 3 pints of water. The liquid cyanide is made by dissolving 3 ounces of pulverized potassium cyanide in one pint of boiling water. Mix thoroughly to form a paste.

When using this paste I have found it best to apply it in the following manner: Provide a small cast-iron vessel or a crucible of the shape of a drip-pan, and spread a thin layer of the paste on the bottom; put the work in the pan and cover that with paste also. Place work and pan in the gas oven and heat until it reaches a nice full red. Dip in sperm, fish or kerosene oil.

To Clean Stained Bottles.—A good way to get the stains out of bottles is to fill them half full of water and then put in a handful or two of cast iron borings, coarse ones preferred; shake well. It will clean any bottle no matter how badly it is stained.

Cement for Fixing Leather or Paper to Pulleys.—Soak six pounds of carriage glue over night; then heat until thoroughly dissolved and add six pounds of white lead ground in oil. Reduce the mixture with oil until it is of a free working consistency. Now add one ounce of nitric acid and stir until thoroughly mixed. The pulley surface should be made thoroughly clean and should be warmed to about 125 degrees F. Then apply the cement and clamp on the leather and let stand twelve hours before using. If the job is done right, the leather will have to be turned off in a lathe in order to remove it.

Liquid Metal Polish.—A good liquid metal polish for cold smooth surfaces, either iron or brass, may be made from the following ingredients: To 3 quarts of benzine add 2 ounces of oxalic acid and $1\frac{1}{2}$ pound of silicate acid powder. This polish may be made in large quantities and set aside for further use provided it is kept in tightly closed bottles, and shaken well before using. Apply the solution with a piece of cloth. When dry, polish with a soft, clean cloth.

TWO VISE HELPS

These two ideas have proven very useful at the shop, so much so that some of the other fellows may care to use them, so here they are.

In Fig. 1 is illustrated a riveting or bending stake. The novel way in which it is made to prevent its movement in the vise jaws will appeal to those who have used the common stake. The stake or bar is bent at right angles a short distance on one end, and two pins that rest, one on top and one underneath the vise jaws, are used in the stake, as shown at A—B. With such a type of stake it is not necessary to exert great pressure on the vise screw (which often breaks them). These pins prevent the stake moving when the hammer blows are struck.

There are many different types of home made jaws for holding threaded screws, bolts, etc., while working on them in the bench vise, but this is a new and clever idea. The jaws have guide rods to make sure they close squarely each time. These rods also act as a rest for the jaws, as shown at B, Fig. 2. When the vise is opened, the jaws spring apart, two small springs being used for this purpose. The springs are on the guide rods and set in recessed holes on the inner side of the screw jaws.

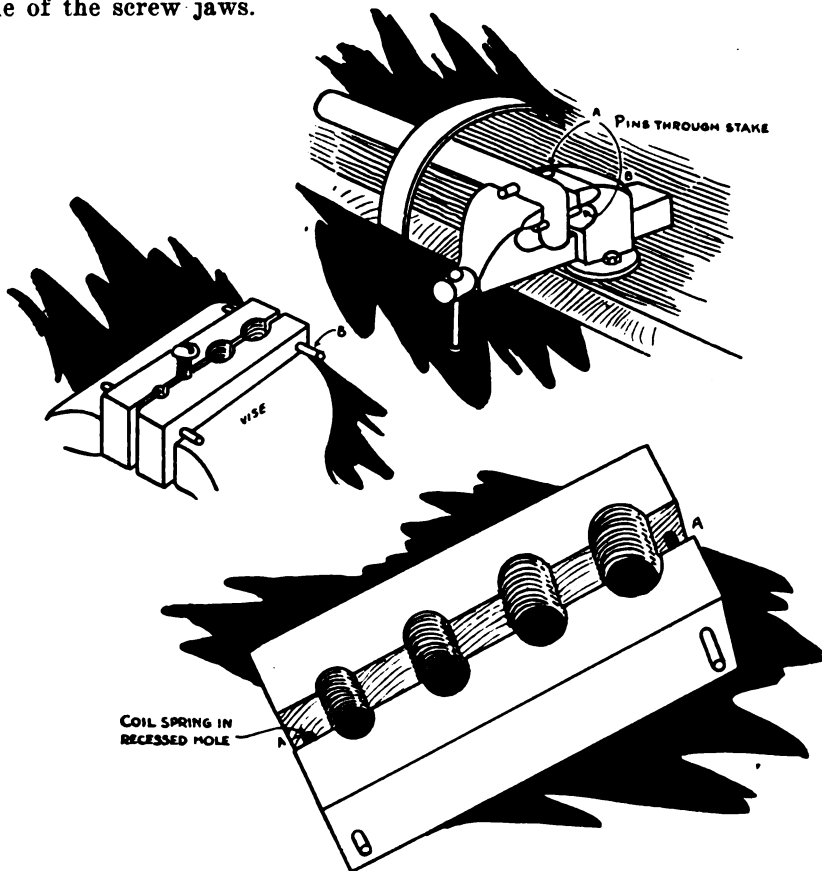

POLISH OR PAINT SPRAY

This simple affair was devised by one shop owner to make the work of polishing auto bodies easier and more economical of polish. The old method of sopping it on with a rag wasted much polish.

The rig shown in the sketch is easily made from a long round can and some short lengths of tube se-

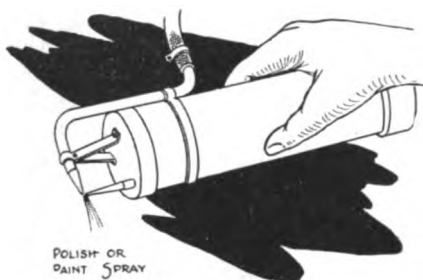

cured to the cap and body, as depicted.

To make it a durable and permanent rig it could be made from 2 inch brass tubing with screw cap. I made mine of some old pipe fittings and piece of 2 1/2-inch pipe. The garage or shop air hose is slipped on the tube A and this air velocity causes the liquid polish to spray as it is tipped out of the holder.

The Kink and

Cha

PULLING OLD BUSHINGS

These three sketches illustrate the bushing pulling methods that are popular with the auto and tractor repair men in our shop. Fig. 1 shows how a blind or bottomed bushing is extracted; the bushing is tapped out part way and then a long bolt is screwed into it, using a nut, washer, and piece of pipe to complete the rig.

Fig. 2 illustrates the pulling of a valve stem guide bushing. A common long bolt the size of the valve stem is used, and a thick washer or

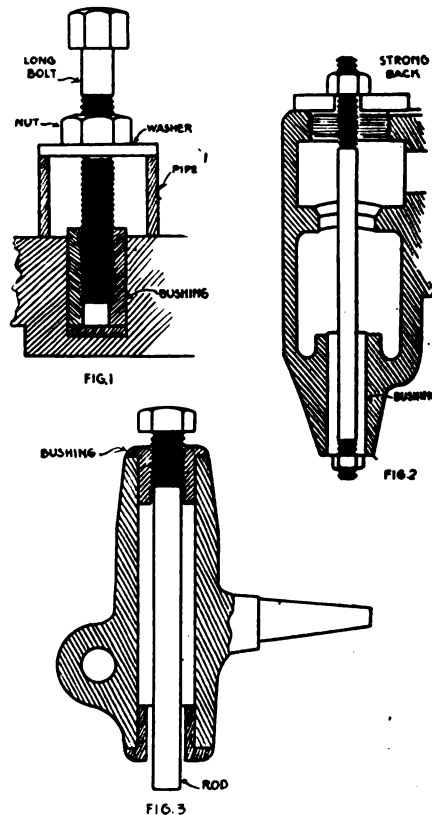

disk is used at the top over the valve cap hole for a strong back.

Fig. 3 pictures an easy way to drive out the collared bushings of steering knuckles, etc. Tap one bushing and put in a bolt, then insert a rod from the other end and drive out as shown.

Top Note Corner

Willey

GLASS TUBING CUTTING KINK

A simple efficient rig for cutting glass tubing such as used for oil gages, sight glasses, etc. The material for making the device con-

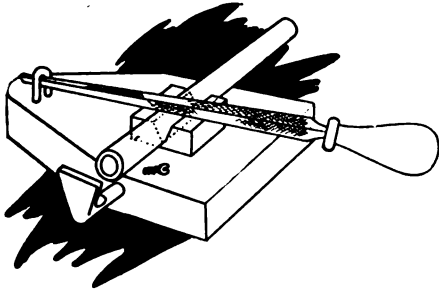

sists of three cornered file, a piece of board for the base, a wood vise block, a staple, and a simple length gauge made of a piece of 1/4 inch rod, one end being flattened and then bent up to act as a stop. The sketch really tells better than words how the device is made. The gauge is put in a hole bored into the base board and adjusted by sliding in and out, and secured by the wood screw A. To use the device, the Vee block is put on the board, and the gauge glass or glass tube is laid in the block. The stop is adjusted to the length desired, then the tip of the three-cornered file is put in the staple, and while pressing down lightly on the handle the glass tube is revolved and scored by the file edge. Then remove the glass tube, light a match and heat the glass at the score, then plunge in water and it will break perfectly square at the mark.

INEXPENSIVE ICE HATCHET

Inexpensive and very serviceable ice hatchets can be easily made from worn-out 14 or 16 inch

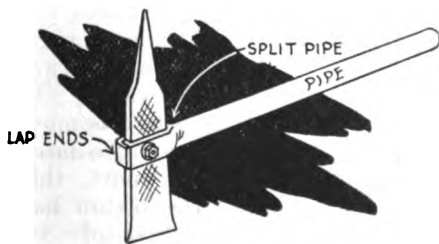

of a length of 1/2 inch pipe is secured to it by flattening the end of the pipe for a few inches, then files or rasps. Such a tool is shown

in the drawing. A hole is drilled through the file and a handle made splitting it and spreading open, and then lapping it around the file. A bolt or pivot through it secures the handle. The cutting edge is drawn out fan shape, while the pick end is made by dressing up the tang.

IMPROVED SHEET METAL SHEARS

Having need of an extra pair of sheet metal shears or snips, I conceived the idea of making a pair of stationary ones for use on the bench. By making a stationary jaw from a section of old wagon spring

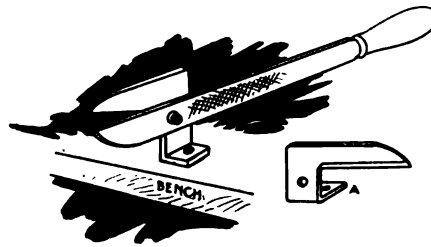

leaf, as shown in the small drawing, and then a moving blade from a worn out 14 inch iron flat file, I quickly and cheaply made a useful, rugged pair of shears. The section of the file that works against the stationary blade must, of course have the file teeth ground out on an emery wheel.

DRILLING SPRING STEEL

The other day I was trying to drill holes in a spring, says C. W. M. Burroughs, but it was no use, they were harder than the drills and I gave it up, and turning to an old mahinist, said, "If you know any way that I can drill holes in that spring, let's hear from you." He replied, "If you had some wood alcohol, perhaps you could drill it." I doubted it, but thought I would try it. I got some wood alcohol and presently the drill did the work. Again, when trying to tap a thread in iron, the hole was a little too small for the plug tap, so that it stuck and would not go. I tried the alcohol on the tap and it worked fine.

OIL PIPE FLANGING RIG

Quite often in the work of repair and overhaul we find it necessary to install small copper tube oil pipes. These are of different size on different motors, and nearly always it is necessary to flange the ends of the pipe. To simplify the work and do a good job, the dies or flanging rig for use in the bench vise was made. This is shown in the sketches.

The rig is in two pieces, U shape, with set screws for clamping each to a vise jaw. The two are guided together by dowel. In using the device, the pipes or tubes are gripped in it and the ends flared as indicated.

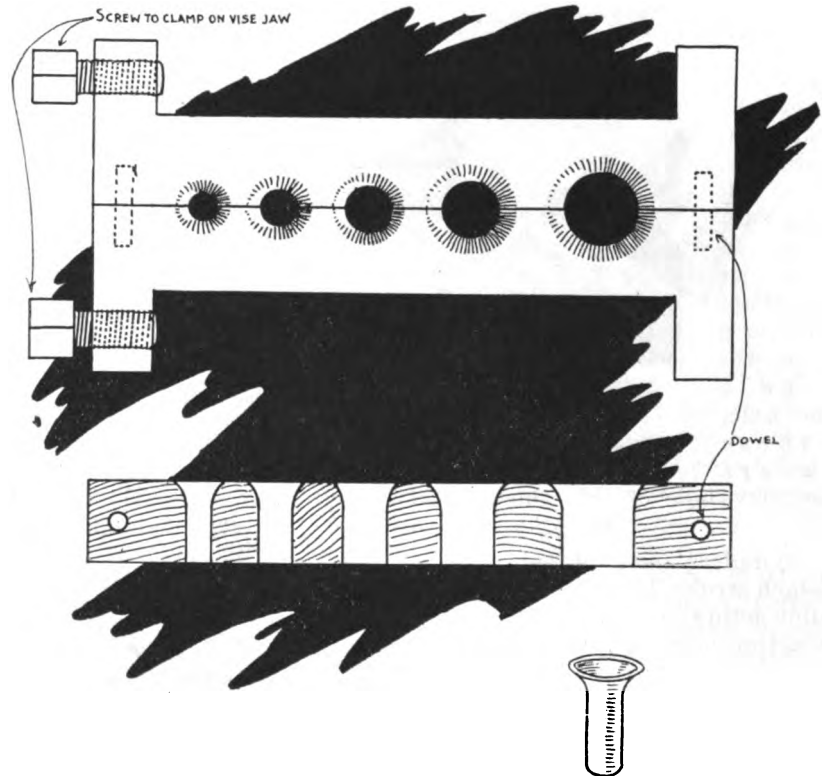

Steam Driven Automobiles

J. L. Haky

Engineers and others frankly admit that the gasoline engine only gives 25% of the power it consumes. The steam automobile being much simpler in construction, operation and care, it is difficult to understand just why the poppet valve engine maintains its supremacy—certainly not because it is efficient as a power producer.



NO one hesitates to admit that the internal combustion engine is an exceedingly wasteful mechanism for the amount of power it delivers as energy, and this being so, it is the purpose of this article to tell something of the steam engine such as is used in one of the better known makes of steam driven automobiles. Considering the economy and simplicity of operation and freedom from various mechanical ailments that the internal combustion is heir to, one wonders why more people don't drive steam cars.

The engine is under the rear compartment of the car, and is a unit with the rear axle. It is hung horizontally; the front end suspended from the frame by a laminated steel strap, and the rear end bolted solidly to the rear axle housing. It has two cylinders, placed side by side, and lying lengthwise of the car. Thus the crankshaft is parallel with the rear axle, and is actually geared direct into it. The driving ratio is $1\frac{1}{2}-1$; a 40-tooth spur gear on the engine shaft engaging with a 60-tooth gear on the axle, and these two gears are on the whole of the transmission.

The cylinders are of 4-inch bore and 5-inch stroke, but as the engine is double-acting, it corresponds to a single-acting engine of four cylinders.

Flexible connections have been provided for both the steam intake and steam exhaust lines, so any

slight movement of the engine and the rear axle is taken care of. This is done by a swivel union on the steam line, and a short hose connection where the exhaust enters the feedwater heater.

The engine shaft receives four impulses per revolution, the same as in an 8-cylinder gasoline engine. The action of the Stanley is much the smoother of the two, however, since it is actuated by the cushion-like expansive force of steam instead of by a succession of hammer-like explosions. Moreover, the impulses in the Stanley are derived from a common source, the boiler, and they are, therefore, perfectly uniform and steady, as contrasted with a gasoline engine, in which it is impossible, even in the same cylinder, to get the same impulse

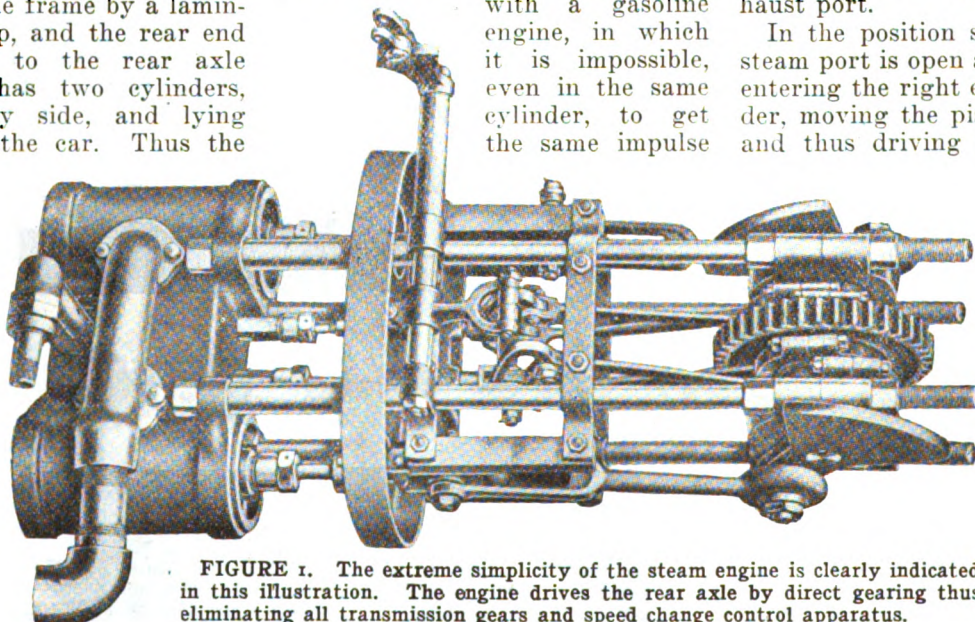

FIGURE 1. The extreme simplicity of the steam engine is clearly indicated in this illustration. The engine drives the rear axle by direct gearing thus eliminating all transmission gears and speed change control apparatus.

twice in succession. As a matter of fact, the term "impulse" is a misnomer. They are not impulses, but a uniform, continuous flow of power.

The engine and valve mechanism are shown in the outline in Figure J. For greater clearness the shaft has been broken into the parts A and B, and these parts separated

to permit the laying of the main crank and the valve link-motion flat on the paper; in reality the crank and link-motion are in planes perpendicular to the paper. The steam chest, of course, is common to both cylinders.

The shaft carries the main crank C, the driving gear D meshing with the rear axle gear G; the forward eccentric is shown as FE, and the reverse eccentric as RE. These eccentrics act the same as small cranks, and are so represented. The passages that lead from the steam chest to the ends of the cylinder are the steam ports; the large round opening in the center, the steam in the cylinder works exhaust port.

In the position shown the right steam port is open a little; steam is entering the right end of the cylinder, moving the piston to the left, and thus driving the crank-shaft in the direction of the arrow and propelling the car forward. At the same time the exhaust steam is escaping from the left end of the cylinder through the left steam port and the exhaust port, which are now connected by the valve. At the given instant the valve is moving to the right, and a little later it will close the right port, this taking place when the piston has made about five-eighths of its stroke. For the rest of the stroke the steam in the cylinder works expansively.

As the piston completes its

stroke the valve reaches a point well over to the right, uncovering the left port, and at the same time connecting the right port with the exhaust port; this admits steam to the left end of the cylinder while it permits the escape of the exhaust steam from the right end.

Thus it is seen that the steam pressure is applied first to one side of the piston and then to the other; that is, the engine is double-acting,

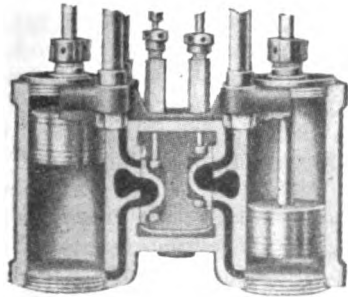

FIGURE H

and this operation will continue as long as steam is supplied to the engine from the boiler.

It may be desired, however, to reverse the car, and it is here that one of the fundamental advantages of the steam engine for automobile use makes its appearance. The engine is simply reversed and the car moves backward.

Suppose the engine, as shown in Figure J, were stopped in the position shown. As it is, steam is entering the right end of the cylinder, pushing the piston to the left and imparting a clockwise motion to the crank-shaft A. It is obvious that to change this motion to counter-clockwise, and reverse the car, it is only necessary to have the pressure of the steam exerted on the other side of the piston, which will move the crank C to the right. Since the entrance and exhaust of the steam are controlled by the slide valve, all that is required is

valve stem which fits freely in the slot of the link; so when the link L is dropped down, as shown in Figure K, the block holds its position on the end of the valve stem and connects the upper eccentric rod with the valve stem. And as the upper eccentric rod is moved by the reverse eccentric RE, which is now on the back of the crankshaft B, the valve is drawn back to the position shown in this figure (K). It will be observed that this has accomplished just what we wanted; the other port is opened and the steam is entering the cylinder from the left and exhausting from the right. This gives the reverse motion to the engine. Of course, both ends of the link are in motion, as there is an eccentric on each end, but the valve is moved by the eccentric rod which is in line with the valve stem; the other end of the link simply idling back and forth without affecting the movement. Thus it is clear that raising and lowering the link brings either the forward or reverse eccentric into operation, so that if this link position can be controlled by the driver the engine can be reversed or driven forward at will.

This is done by suspending the link from a rod or swing arm II, known as the link-hanger. This is connected by a rod to a pedal in the driver's compartment. When the pedal is as far to the rear as it will go, the link is raised, as shown in Figure J, and when the pedal is pushed forward as far as it will go the link is lowered, as shown in Figure K. These positions are known respectively as full forward, and full reverse.

when in the full forward or full reverse positions, as it is in these positions that the valves receive the maximum movements that may be imparted to them by the eccentric arms. There are intermediate positions in the link, however, that reduce the travel of the valve and cut off the steam earlier in the stroke. Referring to Figure J again, it is evident that if the link is slightly lowered by pushing the pedal forward a little, the valve will be carried to the right of the position shown in the figure, as the block slides in the slanting link. Now, since the valve's own motion at the moment is also to the right, this additional movement to the right puts the valve further on its way and causes it to cover the right port sooner; that is, the steam is cut off at an earlier point in the stroke. This operation is called **hooking-up**, because a hook or latch is provided to hold the pedal in this position. Experience has shown that the most efficient position for average driving is with a cut-off at one-third of the stroke, so the hook-up lock has been placed at this point. After starting the car

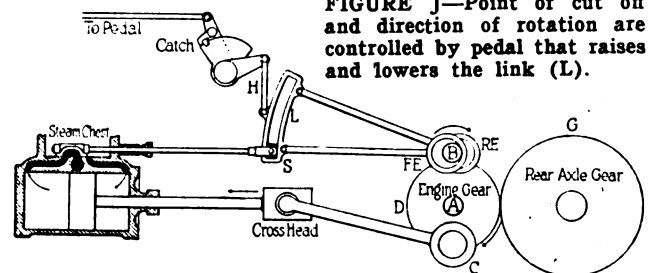

FIGURE J—Point of cut off and direction of rotation are controlled by pedal that raises and lowers the link (L).

the driver simply pushes the pedal forward until the lock engages, and leaves it there. Even in this position the engine is still able to slip the drive wheels on dry pavements.

The bearings of the engine are lubricated by an oil bath. An oil-tight, dust-proof housing surrounds the working parts, so the oil is free to splash. One filling (six quarts) in this case is sufficient for several thousand miles of travel. Since the oil is not exposed to carbon, road dust, or unburned fuel, it retains its life longer, and shows less waste, than gasoline engine supply possibly could.

The cylinders are lubricated by oil pumped into the steam between the boiler and the engine. The engine, therefore, receives a perfectly definite amount of oil per revolution. A sight-feed indicator is mounted on the instrument board.

The mileage obtained on kerosene

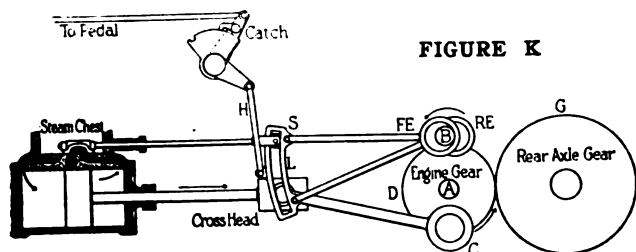

FIGURE K

some means of connecting the valve and valve stem up with the reverse eccentric RE, instead of the forward one FE. This is exactly what is done by the link L. There is a little block S on the end on the

pedal. So it is not necessary to wait until the car comes to a full stop before applying the reverse, but it is easier on the tires if this is done.

The engine has maximum power

is about the same as that obtained on gasoline, by a gasoline car of the same weight. The fuel consumption is proportional to speed, just as in a gasoline car, and ranges from ten to fourteen miles to the gallon, depending on conditions. Owing to the fact that kerosene is comparatively low in price, the car is particularly economical on fuel.

The power plant is rated at 20 horsepower. This may appear low for a car weighing 3,650 pounds, but with a steam power plant it is really ample. The average load on the engine in a car of this weight is not likely to be more than 10 horse-power, which is well within the rating. When more than the rated power is wanted the Stanley power plant can handle a load far in excess of this. In fact, it can carry an overload of two or three times its rating continuously, and can deliver to exceed 80 horsepower for a limited time.

The feature of energy storage must be considered in any discussion of the power rating. The Stanley power plant can develop power greatly exceeding its continuous maximum rating, provided the period of heavy load is followed by a period of moderate load during which time the steam pressure can return to its normal value. Thus, when the Stanley car is driven down a hill, the throttle is closed, shutting off the steam, but not the fuel. And the combustion of fuel continues, storing energy in the boiler in anticipation of the next period of heavy load. This feature enables the 20-horse-power engine to develop 5 horse-power half the time and 35 horse-power the other half, without at any exceeding the continuous boiler rating of 20 horse-power. This range of ability is possible only with the steam engine, and with a boiler of the Stanley type.

Exhaust steam from the engine passes the feed-water, and then to the condenser. The latter operates, just as an ordinary radiator, except that it cools and condenses the steam instead of water. In fact, the condenser is a standard Mayo Radiator. The steam enters at the top, passes through the cellular passages with their large radiating surface, and leaves the bottom in the form of water, which returns to the water tank. A fan back of the radiator has not proven necessary, as is the case with gasoline cars,

because the engine never runs unless the car is moving.

HOW TO TREAT THE TRACTOR

If the motor develops a knock it is important that the cause be investigated **at once** and corrected. If not corrected it may become more pronounced, thereby causing lack of power and tends to shorten the life of the motor.

Never attempt to continue work with kerosene burning tractors when the motor fires only in two or three cylinders. Besides losing power and wasting fuel, it causes raw kerosene to get into the crank case, thinning the lubricating oil.

The worst abuse that can be given a tractor is by racing the motor. This should be avoided at all times.

Do not attempt to engage or disengage gears until clutch has been thrown out entirely, nor while the tractor is in motion.

When changing gears, if the clutch is not entirely disengaged the teeth on the gears will not mesh readily, and there is danger of breaking off the edges of the teeth so that in time they will not remain in mesh.

Always close the throttle, to slow down motor, when shifting gears.

Always hitch to the place provided; never hitch a chain or rope around the rear axle or rear axle housing, etc.

When pulling a heavy load, or when tractor gets stuck be sure to keep your foot on the clutch pedal. Do not race the motor or let the

clutch in suddenly, as such procedure might cause the front end of the tractor to "rear up" from the ground. Release the clutch immediately if the front of the tractor starts to leave the ground—this will bring it down at once.

If the tractor gets stuck, pull out in low gear.

Do not attempt to pull trees or stumps, or similar work which brings the tractor to a sudden standstill.

It is very important that the air cleaner or washer is kept properly operating, cleaned out, or filed with water, as may be necessary, at all times. If due precaution in this respect is observed, not only the life of the motor will be lengthened but power will be increased.

Do not allow the tractor to run down-hill with the gears in neutral or the clutch released. Engage the gears either in low or intermediate speed and use the throttle to govern the speed of the engine. Putting the tractor in low gear acts as an effective brake.

The importance of correct lubrication cannot be too strongly impressed. The grade of oil recommended by the manufacturer should be used in the engine and transmission. The proper oil level must be maintained at all times. Do not forget that lubricating oil wears out and gets dirty and should be replaced frequently. Clean oil will protect the engine bearings and cut down spark trouble. By purchasing high grade lubricants you insure all working parts against premature wear.



Care and Operation of Hydraulic Hoists

HOWARD ADRIAN

HYDRAULIC mining, hydraulic barber chairs and hydraulic this and that are terms one sees and hears with considerable frequency and within the last year or so the hydraulic hoist as applied to motor trucks has become almost as common. Therefore, taking the subject of hydraulic hoists for my text and using the Wood Hydraulic Hoist as an example I will endeavor to shed some light on the operation and construction and care.

Primarily hydraulic hoists are intended to unload a truck loaded with stone, sand, coal or other similar materials with a minimum of time and labor and they answer the purpose admirably. All that is necessary to unload two or three tons of sand is for the truck driver to throw in a dog clutch on the driving shaft by pushing a small lever. The hoist does the rest and in less than five minutes time the truck has been unloaded and is on its way after another load.

The principle of operation follows somewhat the idea of a steam engine—oil is pumped under pressure into a cylinder in which is a piston and since the oil will not

compress, the piston is forced outward, elevating one end of the truck body and dumping the load.—simplicity itself. By referring to the illustration it will be seen that the oil is led into the pump through a pipe (3) from the expansion chamber (4) at the cylinder head and is then forced by means of a gear pump (6) through another pipe (7) that leads to the base of the cylinder.

The dog clutch on the driving shaft is engaged by throwing forward the small lever (8) which extends through the floor. To raise the body the control lever (9) (on front of the expansion chamber) must be set at its highest point. To lower the body it must be set at its middle position and to hold the body at any position this lever should be set at its lowest point. An automatic stop prevents the body from being raised beyond a certain point.

The expansion chamber should be kept filled to within five inches of the top when the hoist is raised. During summer months a heavy, non-foaming auto engine oil should be used and in winter 15 per cent

of kerosene should be added or better still, use Ice Machine Oil.

If an oil leak should develop at the cylinder head (5) or between the packing nut (10) and the piston (1), the head or nut should be turned down. A few light taps of a hammer through a wooden block against the lugs will generally suffice. Care should be taken that neither cylinder head nor packing nuts become broken. If repacking becomes necessary any good brand of steam packing may be used. This may also be used with the pipe packing nuts, of which there are four (11) and which make all pipe connections. These packing nuts should be turned-up-just-tight-enough-to prevent oil leaking at the joints.

The gear pump is driven by a chain (12) running from the driving shaft sprocket (14). This driving shaft (15) is carried from the transmission and is supported by the bracket (16) which is bolted to the support angle irons. The chain should be kept fairly tight and this is accomplished by moving the pump away from the cylinder. The pump is held in position by two bolts (17) that extend through the angle iron into its base. By loosening these two bolts and the pipe packing nut are loosened the pump may be moved, the angle irons being slotted to permit movement of

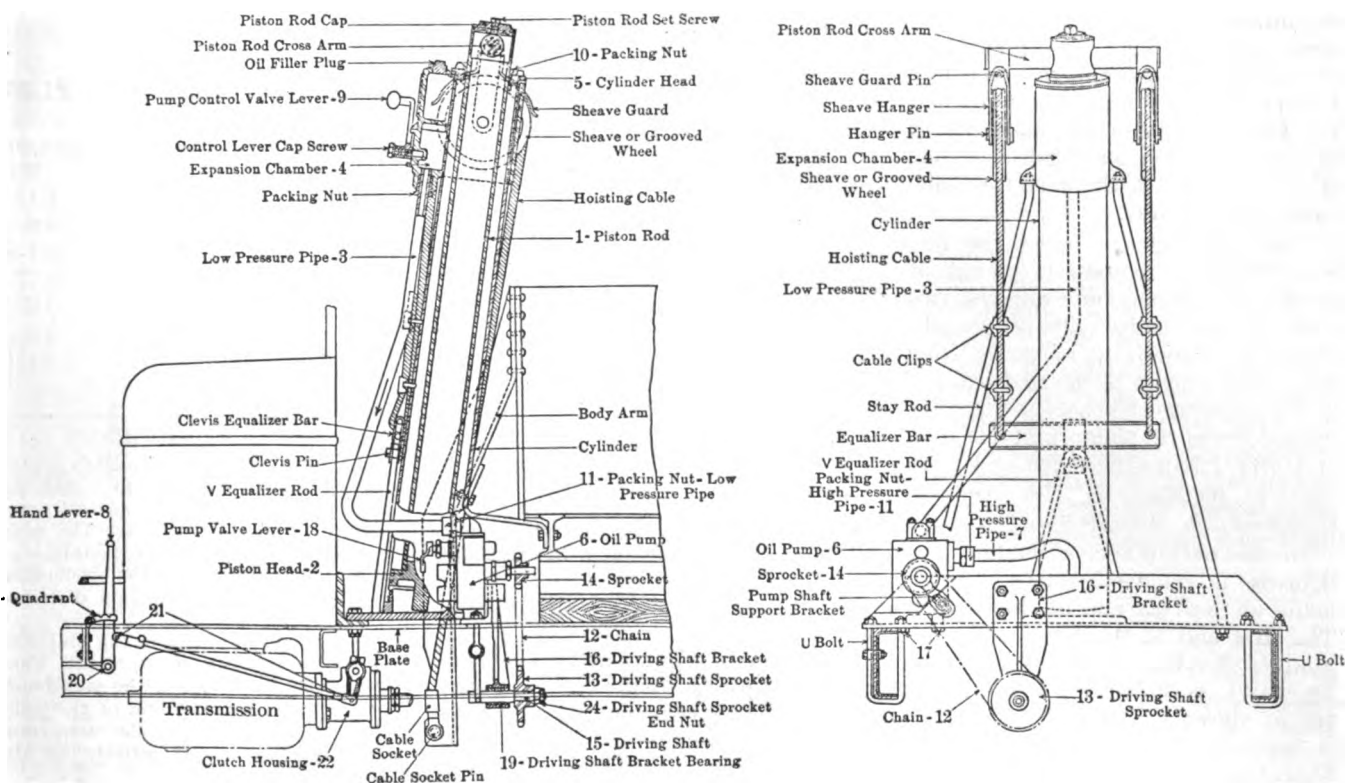

WOOD HYDRAULIC HOIST AS APPLIED TO RIKER TRUCKS

the pump back or forth as may be desired. If the chain is very loose it may be necessary to remove a link from the chain and usually this is easily accomplished as the chains are provided with master links.

The joints of the control lever (9), pump valve lever (18) and tie strap, should be oiled frequently. The chain should be kept cleaned and always well lubricated. The

driving shaft bearing (19) should be oiled from time to time as should the hand lever bearing (20) and rocker shaft lever jaws (21). The clutch housing (22) should be kept filled with grease. The clutch housing cap (25) may be easily removed for this purpose as it is held in position by four small bolts.

The driving shaft sprocket end nut (24) should be kept tight. The

four bolts, cylinder base to angles, should be examined and tightened as should the equalizer V-nuts. The nuts on three U-bolts and one I-bolt, holding angles to frame, should be frequently examined and kept tight.

While the foregoing applies only to the one make of hoist mentioned the principle of operation is practically the same for any other hydraulic hoist.



MOTOR TRUCKS EQUIPPED WITH HYDRAULIC HOISTS FOR EASE IN HANDLING ROAD BUILDING MATERIALS. THE HOIST IS LOCATED DIRECTLY BEHIND THE DRIVER'S SEAT.

CONVOY WORKSHOP EXPERIENCES IN FRANCE

T. Northwood

In a recent number I promised to tell something of the methods we adopted and the materials we used for heating the interiors of the ambulances from the exhaust. I suppose this was recommended for the benefits of the patients in the winter when on some occasions they would be in the cars for some considerable time.

The materials required for one complete set are seven pieces of of 1 3/4 inch pipe, four elbows, two tees, one butterfly valve and eight brackets made out of 1 x 1/4 inch flat. The pipes are carried around the inside of the car about five inches from the floor and an inch and a half from the sides and were held in position by the brackets shown in the illustration.

In the first place, a part of the flooring is removed and a start is made at the rear end of the muffler. The first end of the tee piece being made a driving fit and the butterfly valve is fitted on behind this tee as shown, the handle of which is made of 1/4 inch round and is operated from the inside of the car. The piece of pipe that is

screwed to No. 1 tee is fitted to No. 2 immediately above it inside the car. The pipes must be cut off correctly to suit the length and width of the car. The outlets for the exhaust gases emerge from the sides of the car at the rear underneath

but it was one of my last jobs with the Convoy and I didn't get to hear very much about it but if anyone anticipates installing an outfit of this kind the drawings will give a good idea of how the job was carried out.

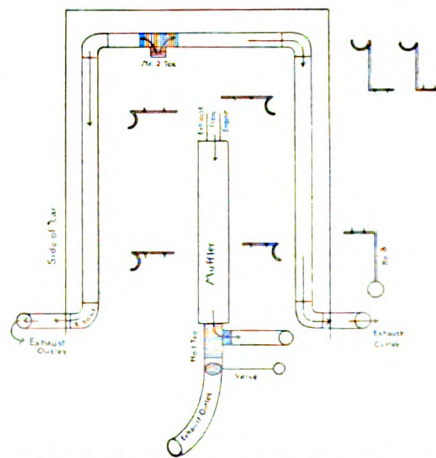

CONSTRUCTIONAL DETAILS OF MR. NORTHWOOD'S AMBULANCE HEATER

the seats and are carried by brackets No. 8.

After all the parts are all in position the pipes inside the car are covered with wire netting for protection. I assume that this undertaking was satisfactory from the reports made by the drivers

MILES TRAVELED IN PLOWING ONE ACRE

| Width of Furrow | One Plow Miles | Two Plow Miles |
|-----------------|----------------|----------------|
| 10 inches | 9.9 | 4.19-29 |
| 11 " | 9 | 4.5 |
| 12 " | 8.25 | 4.1-8 |
| 13 " | 7.5 | 3.75 |
| 14 " | 7 | 3.5 |
| 15 " | 6.5 | 3.25 |
| 16 " | 6.1-6 | 3.1-12 |

LEAVE IT TO HENRY

Newspaper reports indicate that Henry Ford proposes to build an automobile that will undersell any car now on the market. The plan includes the location of factories at strategic locations for the economical collection of materials and distribution of the product.

Although Mr. Ford is the majority stock holder of the present Ford Motor Co., he resigned the presidency of that company the first of the year. It is understood that the new company will be owned entirely by Mr. Ford and his family.

Suggestive Applications of Electric Arc Welding



Fig. 118A. FLUE WELDING. 2'' Flue—Locomotive Back Flue Sheet. Actual Time: 2 minutes 2'' Flue; 7 minutes 5'' Flue. Electrode 2'' Flue— $\frac{5}{32}$ ''—90-100 Amp. 5'' Flue— $\frac{5}{32}$ ''—120-130 Amp. The total time to weld a complete set of flues depends on the condition of the flues and flue sheet. A fair average may be calculated from the above figures by adding 50% to the total time for rest periods.

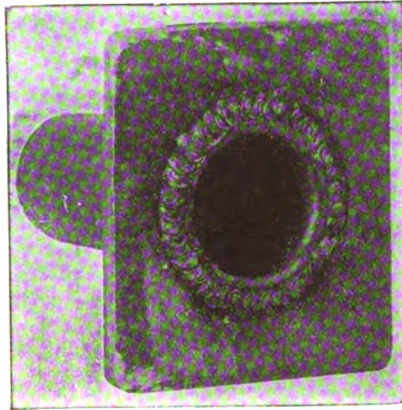

Fig. 118B. FLUE WELDING. 1. Put flue in as if it were not to be welded. 2. Send the engine out for a few trips to let the tubes take their set. 3. Sand blast the flue sheet. 4. Weld flues. A heavy bead of welded metal around the flue is not desirable. Put on the smallest bead that can be thoroughly welded to both flue and sheet.

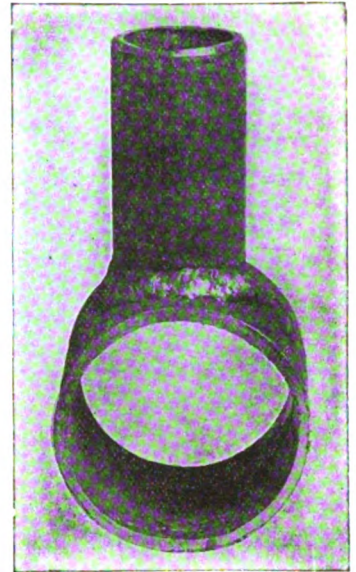

Fig. 118C. PIPE WELDING. See "Building Up Operation" for speed of work. The welded joint is stronger than the threaded joint. Steel or wrought iron pipe only may be welded.



Fig. 118D. FLANGED HEAD BACKED INTO SHELL.



Fig. 118E. FLANGED HEADS—BOILER PLATE.

$\frac{3}{8}$ '' Plate—Speed—7 ft. per hour, $\frac{5}{32}$ '' Electrode 130 Amperes. For High Pressure, joints should be welded inside and out

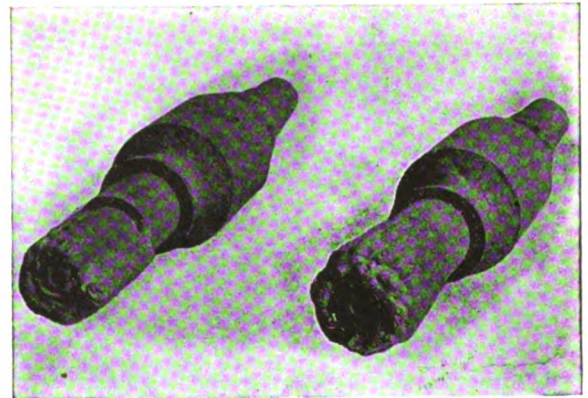

Fig. 118. Steel parts incorrectly machined built up by the arc welder and afterwards re-machined to proper size.

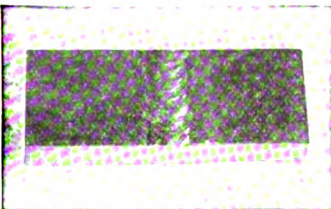

Fig. 118H. BOILER PLATE WELDING.

| Ft. Per Hr. | Size | Electrode | Current |
|------------------|------|-------------------|-----------|
| $\frac{3}{8}$ '' | 7 | $\frac{5}{32}$ '' | 120 Amps. |
| $\frac{1}{2}$ '' | 8 | $\frac{5}{32}$ '' | 110 Amps. |
| $\frac{3}{4}$ '' | 6 | $\frac{3}{16}$ '' | 150 Amps. |

Above figures include straight welding time only. Loss of time in handling the job must be taken into account on each job. Vertical or overhead welding speeds are at least 50% below speeds given above. $\frac{1}{8}$ '' wire is used to fill in bottom of seam.

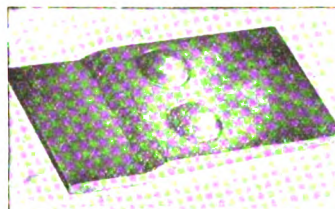

Fig. 118J. WELDING IN PLACE OF CALKING. Speed of work depends on amount of metal added. Strength of joint may be raised 25% doing the work at three times the welding speed given in table for any thickness plate above $\frac{1}{4}$ '' This makes a single riveted joint equivalent to a double riveted joint and makes a double riveted joint as strong as the original plate. Joints welded in this manner stand much abuse without leaking.

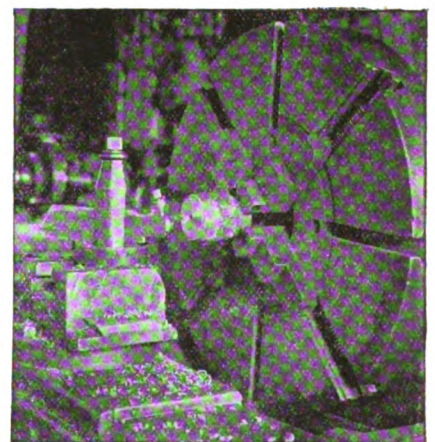

Fig. 118K. BUILDING UP OPERATIONS. (Note that the weld is easily machined). $\frac{5}{32}$ '' Electrode, 130 Amp., 20 Volts will deposit one pound of metal in approximately 30 minutes. $\frac{3}{16}$ '' Electrode, 175 Amp., 22 Volts will deposit one pound of metal in approximately 20 minutes. Using $\frac{5}{32}$ '' Electrode, one cubic inch of steel may be deposited in about $7\frac{1}{2}$ minutes. The metal when deposited on mild steel by the metal electrode process will always be soft and easily machined. The carbon electrode process should be used for building up operations only when the built up piece can be later annealed to take out contraction strain.

Electric Welding—III.

A. F. DAVIS

TO mention all of the applications of this process to even the fields covered by this magazine, is beyond the limitation of space, and a book might be written on the same. In figures 118, 118A, B, C, D, E, H, J and K are shown a number of the more simple applications. These are fundamental applications and variations of these applications will cover a large field. This process may be successfully used for building up worn places, cracks,

present in the arc a few ultra-violet rays, which would effect the eyes of the workman unless they are protected in some way. This is done by using a hand shield, shown in figure 142, or a head shield is usually used for metal electrode work, and the head shield for carbon electrode work, as the head shield leaves both hands of the operator free to manipulate the electrode and filler rod. It is also the usual custom for the operator to wear leather gloves, as when the bare hand is used a result is secured similar to severe sunburn. There have been a great many old foggy theories as to the effect of the rays upon the operator's body, which are, in the light of long experience, ridiculous. Numberless operators have been using this equipment for a long number of years and are in perfect health.

A good deal has been written on the matter of electrode, and a good deal of theory expressed, but speaking from practical experience we find that in 95 cases out of 100, any good soft steel electrode of not to exceed 10 points (.10%) carbon and 50 points (.50%) manganese, sulphur and phosphorus being as low as possible, a very successful weld will be secured. Various electrode manufacturers have made claims which are ridiculous on the face of it. There are cases, of course, where

special electrode is required but for the majority of jobs, an electrode similar to that described above will give excellent results.

USEFUL INFORMATION

To find circumference of a circle multiply diameter by 3.1416.

To find diameter of a circle multiply circumference by .31831.

To find area of a circle multiply square of diameter by .7854.

Area of rectangle. Length multiplied by breadth. Doubling the diameter of a circle increases its area four times.

To find area of a triangle multiply base by $\frac{1}{2}$ perpendicular height.

To find surface of a ball multiply square of diameter by 3.1416.

To find solidity of a sphere multiply cube of diameter by .5236.

To find side of an inscribed square multiply diameter by 0.7071 or multiply circumference by 0.2251 or divide circumference by 4.4428.

To find side of an equal square multiply diameter by .8862.

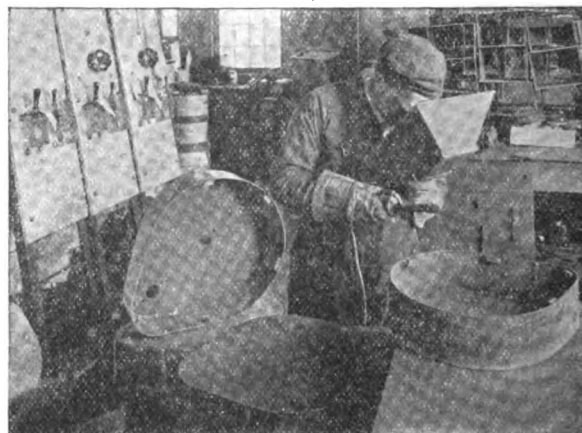

Fig. 104—Welding steel sheets together to form gear cases. The lugs on the inside of the case are also welded on. Jobs similar to this can be found in hundreds of manufacturing plants.

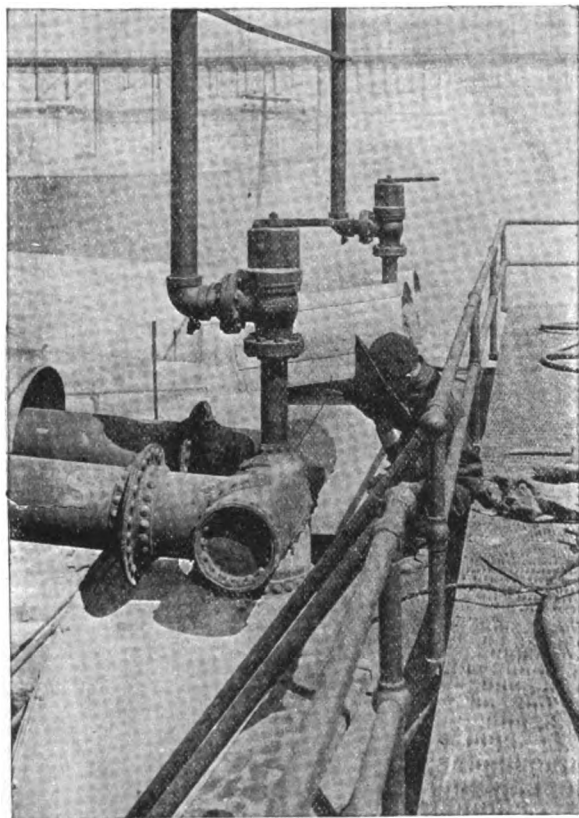

Fig. 14—Electric Arc Welder used by the Standard Oil Co., to caulk leaks in vapor lines and oil stills. The vapors are very inflammable and every joint must be absolutely tight, hence welding is used in addition to riveting. (See Fig. 73.)

filling in low spots, etc. Each person reading this article will undoubtedly find numberless adaptations of the applications shown in his own plant. (See figures 115, 104, 42, 30, 14 and 76 for practical applications.)

In welding by the electric arc, care must be taken so that the operator will be properly protected from the rays of the arc. There are

cases, of course, where

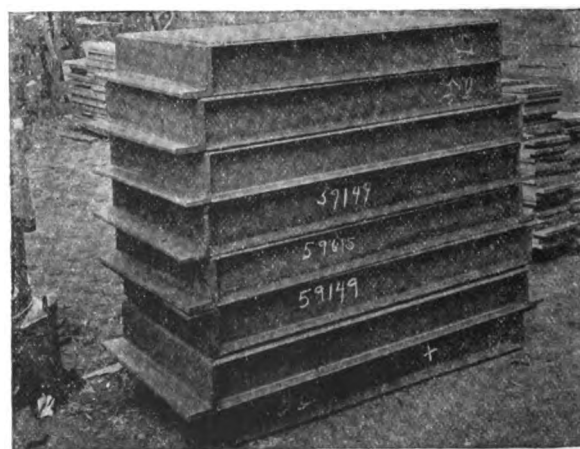

Fig. 115—Steel Machinery Bed-plates manufactured by use of the Arc Welder

Square. A side multiplied by 1.1142 equals diameter of its circumscribing circle.

A side multiplied by 4.443 equals circumference of its circumscribing circle.

A side multiplied by 1.128 equals diameter of an equal circle.

A side multiplied by 3.547 equals circumference of an equal circle.

Square inches multiplied by 1.273 equals circle inches of an equal circle.

To find cubic inches in a ball, multiply cube of diameter by .5236.

To find cubic inches in a cone multiply area of base by 1/3 the altitude.

Doubling the diameter of a pipe

7 1/2 gallons, 1728 cubic inches, and weighs 62 1/2 lbs.

To find the pressure in pounds per square inch of a column of water multiply the height of the column in feet by .434.

Steam rising from water at its boiling point (212 degrees) has a pressure equal to the atmosphere (14.7 lbs. to the square inch).

A standard horse power: The evaporation of 30 lbs. of water per hour

for a feed temperature of 100° F. into steam at 70 lbs. gauge pressure.

To find capacity of tanks any size; given dimensions of a cylinder in inches, to find its capacity in U. S. gallons; Square the diameter, multiply by the length and by .0034.

To ascertain heating surface in tubular boilers multiply 2/3 the circumference of boiler by length of boiler in inches and add to it the area of all the tubes.

One-sixth of tensile strength of plate multiplied by thickness of

plate and divided by one-half the diameter of boiler gives safe working pressure for tubular boilers. For marine boilers add 20 per cent To find the capacity of an air compressor in cubic feet of free air per minute: Multiply the area of low pressure cylinder (on compound compressor), or area of simple compressor cylinder in square inches, by the stroke in inches, and divide by 1728; and multiply this result—

- (a) In single acting, simple or compound, by the R. P. M.
- (b) Double acting, simple or compound, by 2 x R. P. M.
- (c) Duplex double acting, by 4 x R. P. M.

A tidy shop is a standing advertisement. Don't have a scrap heap at the door.

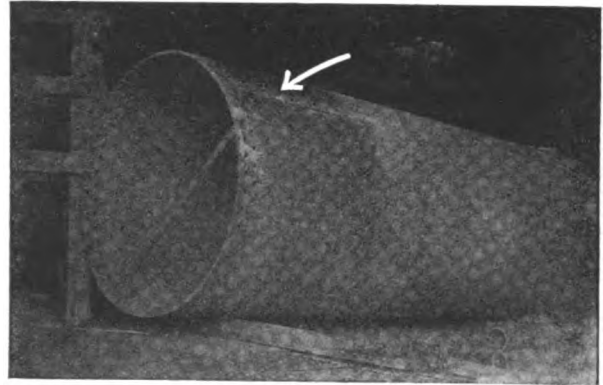

Fig. 76—Long, vertical seam in boiler plate construction made by arc welding

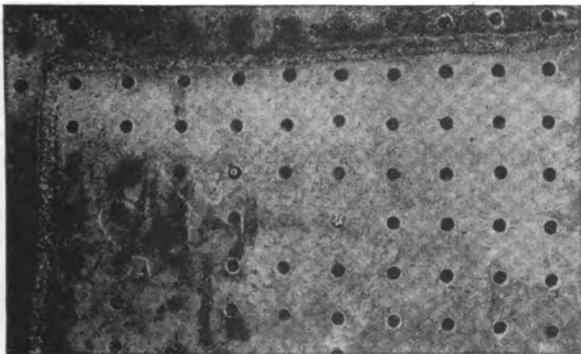

Fig. 42—Vertical seam patch made by arc welding in locomotive fire box

increases its capacity four times.

A gallon of water (U. S. standard) weight 8 1/3 lbs. and contains 231 cubic inches.

A cubic foot of water contains

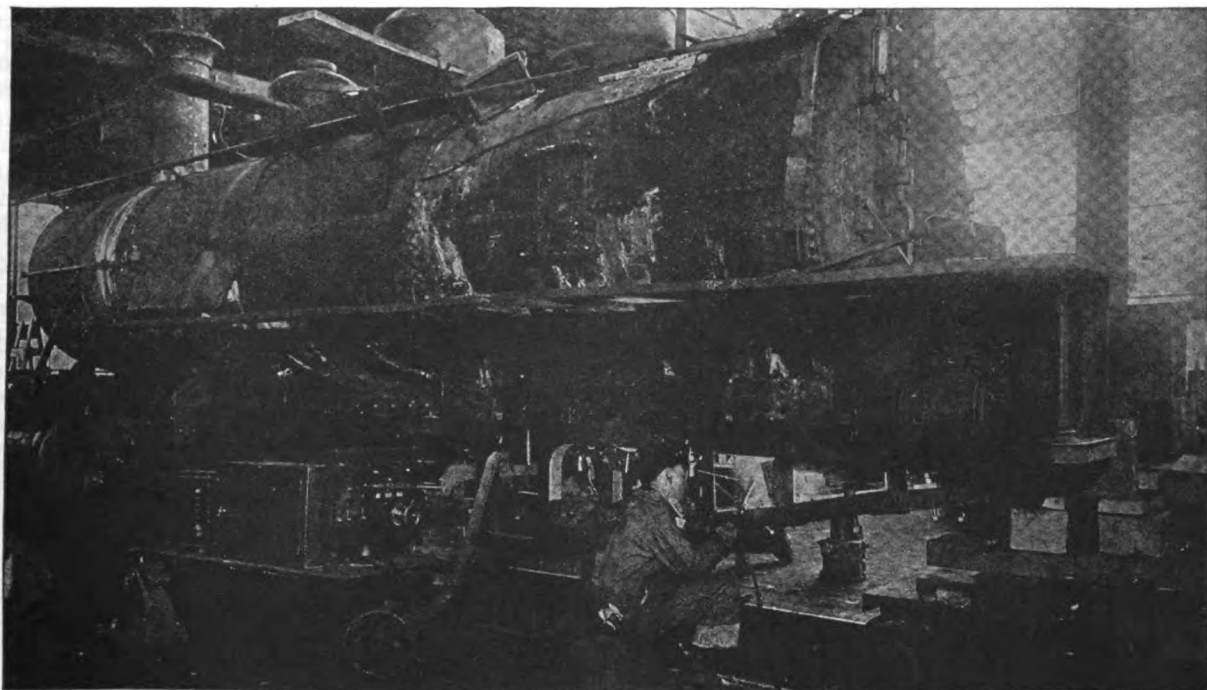

Fig. 30—Welding a locomotive side frame, using a portable arc welder. The same week that this photo was taken \$6,000 were saved through arc welding on this welder

WHEN A BUYER MISREPRESENTS HIMSELF

Ralph H. Butz

It is a well-established principle of law that a party to a contract has the right to know with whom he is dealing. Thus, where a certain company sold its business to another company, and the latter continued to deliver goods to the customers of the former company without notifying them of the change of ownership, they could not collect for the goods so delivered, as there was no contract for its delivery.

The Supreme Court of Maine recently rendered an interesting decision bearing on this question. A man whose real name was Roche or Towle. The minds of the parties met; and Green could not afterward claim that he did not mean to sell to that particular man.

The court also cited a case in which certain shippers of goods sought to recover from the transportation company for the value of the goods shipped, claiming that delivery had been made to the wrong party. The history of the case was that a swindler appeared in Boston and represented himself to be a certain reputable merchant of Dayton, Ohio, by the name of Edward Pape. He bought goods which were shipped to Pape, and delivered the goods to the man who bought them. The shippers claimed that the transportation company should have delivered the goods to the man with whom they thought they were dealing.

But the court held otherwise. The opinion says, "There was a de facto contract, purporting, and by which the plaintiffs intended to pass the property and the possession of the goods to the person buying them; and we are of the

opinion that the property did pass to the swindler who bought the goods. The sale was voidable by the plaintiffs; but the defendant, the carrier by whom they were forwarded, had no duty to inquire into its validity. The person who bought them, and who called himself Edward Pape, owned the goods, and upon their arrival in Dayton had the right to demand them of the carrier."

The common sense of the rule is this: If the seller allows himself to be deceived as to the identity of the person he is dealing with, he cannot expect an innocent party to discover the fraud, or to make good the result of the deception practiced on the seller.

A nice distinction is brought out in this case. At one store the swindler said he was the brother of Edward Pape, of Dayton, instead of Mr. Pape himself. In that case it was held that there was no contract, as the seller thought he was dealing with Edward Pape, through his agent, and not with the man who stood before him; and in this case the carrier could not defend upon the ground that they had delivered the goods to the real owner.

The law seems to be plain that when you sell goods to the man before you, you give him title, and cannot recover the goods in the hands of third parties, if he defrauds you. That is, if you mean to sell to a given man, you cannot avoid the sale on the ground that his name is not what he told you it was.

This does not mean, of course, that the man who perpetrates a fraud of this kind cannot be punished. As between the original parties, the sale is voidable, and the seller can recover the goods and damages for the fraud—if he can find the swindler.

(Copyright, 1919, by Ralph H. Butz)

DRAIN VACUUM TANK

At frequent intervals open the drain cock at the bottom of the vacuum tank. Usually a few drops of water and rust flow before the gasoline. The fact that often there is no flow until the passage is opened with a piece of wire indicates that there is solid matter over the drain which, if it works through, will cause carburetor trouble.

Among the first great institutions of learning to officially recognize the motor car was Columbia University. In May, 1900, the faculty of that university announced a course in "Tractor Engine and Carriages."

RADIATOR REPAIR STAND

In shops where radiator repairing is done the repair stand shown in the accompanying drawing is quite a convenience. It is simply constructed of pipe and fittings and

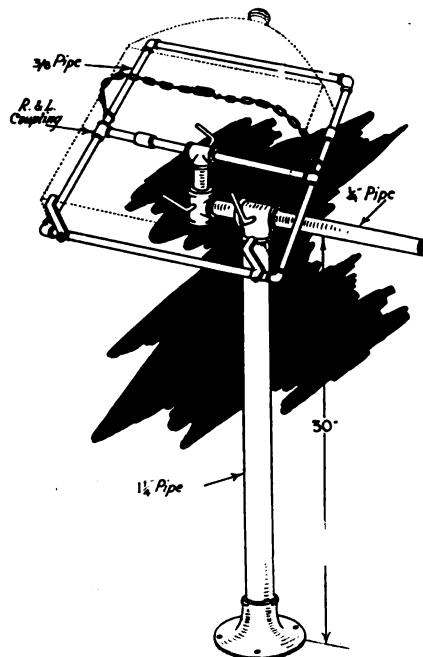

is easily adjustable to any position desired.

A spring is inserted in the center of the chain which allows of holding the radiator under repair to be held tightly.

The question of law was as to whether the title to the property had ever passed from Green to Towle (or Roche). Green claimed that it had not, and that since Roche had deceived him as to his name, there was no sale; that Roche had no more right to the property than if he had stolen it. In that case, of course, Martin had no good title to the property, and Green could recover it; for the principle of law is well-established that a thief can give no title to stolen property, as against the rightful owner.

But the court held differently. The opinion of the Chief Justice is that while there was fraud, it did not render the sale void. As between Green and Roche the sale was voidable. That is, Green might have demanded the return of the property from Roche on the ground that Roche had deceived him as to his identity. But when the property passed into the hands of an innocent purchaser, such third party was vested with good title.

The point is that while Green was deceived as to the name of the person with whom he was dealing, there was no mistake as to the person—the actual human being to whom he sold the property. He meant to sell to the man before

Queries—Answers—Notes



THIS department is the meeting place where you are free to ask for information, answer questions, discuss shop matters and business conditions and any other notes you feel would be of interest to a fellow mechanic. Make use of this Department as often as desired.

Let's Have More of the Same.—I am sending you a floor plan of my shop which was made by building an addition to an old dwelling house and having a floor space of 19 by 38 feet.

I do all kinds of work including shoeing, wagon work and such other general work that comes to the small country town shop.

The drawing I am sending shows the first floor plan of my shop. The doubleforge is four feet wide and eight feet long over all. The chimney is built with a partition all the way up: a double chimney. To improve the draft I left out two bricks three courses up from the top of the hearth or fire-pot. I have worked in eight different shops and visited where I had the opportunity and have seen chimneys built in all kinds of ways but my experience has been that leaving the two bricks out is by far the best, then build the chimney about three feet above the comb of the roof and you will have a chimney that will draw.

I have two anvils, one weighing 148 pounds and the other 170 pounds which are not too heavy for general work. The slack tubs are shoved partly underneath the forges. To make an iron rack that would occupy the least amount of room I spiked three pieces of 2 by 4 inch timber from floor to ceiling and then bored holes in them at an angle for pins to support the stock. I used 7-8 inch pins eight inches long at the bottom for the heavy stock. The pins at the top for the lighter iron were seven inches long and 5-8 inches in diameter.

My Canedy Otto punch and shear is a very handy thing for me in turning out irons for coal cars. My No. 203 Champion drill is partly underneath the stairway but is perfectly accessible and convenient nevertheless, and allows plenty of room for drilling. The stove is taken down in the summer and when not in use the wheel stand is moved into an unused corner out of the way.

I equipped my first fire with a Champion electric blower three years ago and it has caused no trouble since that time. The other fire is fitted with a Champion hand blower.

My shoeing floor is large enough for one team at a time but I am personally of the opinion that that is enough in a small shop at one time. Outside of the shop I have a pair of mule stocks which was made by putting four posts in the ground with a roller on each side and a belt to raise the animal from the ground. I shoe some bad ones and those who have ever shod mine mules will know how they act.

The high prices certainly made us blacksmiths in this section put on our thinking caps so we got together and fixed up a uniform scale of prices and so far we are sticking together fine and that is the only

way we will ever get what is coming to us—simply stick together and demand it.

Harry A. Neil, Pennsylvania.

Removing Speedometer Chain.—Will you please explain the way to remove the linked chain from speedometer cables. I have three and can't get them out.

Subscriber.

Open up the chain link that holds either the upper or lower clutches and remove the clutch. The chain can then be easily removed from the other end of the cable. A piece of wire attached to the end of the chain will be the simplest and quickest way of replacing the chain in the cable.

Brass is an alloy of copper and zinc, the proportion of either metal determining the color and character of the

dences of this loss, which, with due care need not be excessive. For many purposes scrap brass is simply melted and a little extra zinc or spelter added, usually after the crucible has been drawn from the fire to make up the unavoidable loss which may vary from one to five per cent, according to conditions. Fluxes are not generally employed.

Benton.

A Real Convention.—The 12th annual convention of the Nebraska Association of Blacksmiths, Horseshoers and Wheelwrights held in Auburn on February 27 and 28 was pronounced the most interesting in the Association's history.

Among other things accomplished at this convention was the adoption of a uniform price list based on cash and a maximum credit of 30 days and making all accounts payable the first of the month. The Association also took steps toward the formation of a Mutual Fire Insurance organization among its members, details of which are yet to be worked out.

The financial report given by the secretary-treasurer indicate that the organization is in a flourishing financial condition. Interesting demonstrations of acetylene welding, thread cutting and disc sharpening were conducted by manufacturers' representatives at the shop of Mr. Good. Officers elected for the year were: G. C. Casten, president; S. P. Johnson, vice president; C. C. Good, secretary-

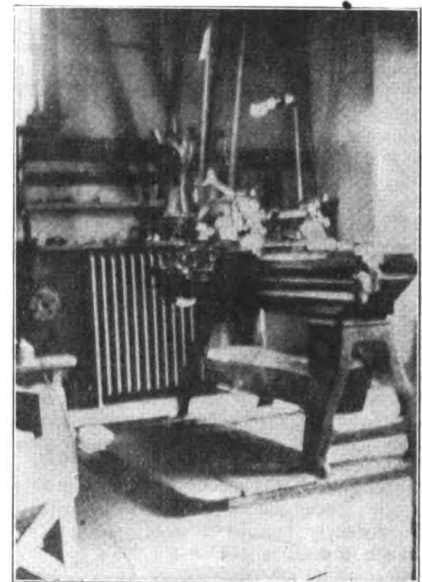
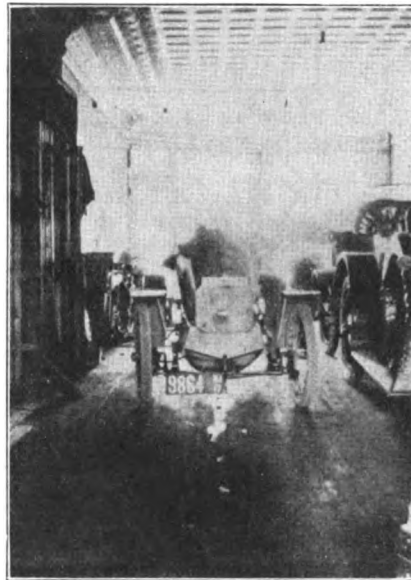

THE AUTO REPAIR SHOP AND LATHE CORNER OF MR. GEORGE GRILLIER'S FRENCH MACHINE SHOP IN NEW JERSEY

metal, for instance, the more zinc the lighter the color of the brass and the more copper the darker the color. This gives us what is broadly classified as yellow or white brass and red brass.

The melting point of zinc is so much lower than that of copper that it is usually added after the copper has been melted in order to avoid loss from oxidation. Some loss is of course inevitable in any case and this loss will be greater in melting up scrap brass where the loss takes place through volatilization of the zinc and partly through volatilization and both the blue flame that plays over the crucible and the dense clouds of oxide of zinc, produced by the vapor of the burning zinc when it comes into contact with the air, are evi-

dent. The next convention will be held at Fremont on October 15 and 16.

Visiting delegates were much impressed with the possibilities of automobile repair work in conjunction with their business and after adjournment an inspection tour was made of the principal garages and repair shops in Auburn.

This most successful and enjoyable convention agreeably closed with a memorable banquet given the visitors by the Auburn Commercial Club.

"There's a Reason"—I did not receive my copy for February, so you will please send me one as I cannot get along very well without it and this is the first one that I have missed since opening my repair shop here.

To say that I appreciate your efforts to help the blacksmith is putting it rather mildly, as I can truly say that my success, has been attained through the application of the material in the magazine.

I have a good shop, though not a large one (24 by 40 feet) and am in a good location. I have a five horsepower gasoline engine, 20 feet of line shaft, 50 pound Little Giant hammer, power blower, 20" floor drill equipped with back gear, self feed, etc., Brooks cold tire setter, floor emery stand, and all kinds of small tools, vises, etc., last but not least a Vulcan welding machine.

I get work, especially oxyacetylene welding, from 50 miles around, the work coming past the doors of welders in other towns. Why? I do not mean to brag but I feel that the reason is because they do not read the Auto & Tractor Shop or any other journal about welding.

P. W. Peterson, North Dakota.

Started Without Experience — Four years ago last November I started business without any previous experience. I took up horse shoeing and general repair work. The business was run down when I took it over but I stuck to it and now have more business than I can handle by myself and am planning an addition to my shop.

I like the trade and firmly believe there are better days ahead for the blacksmith and the general repair man.

My shop is a frame building 65 by 28 feet and so far I do not have any power equipment but I am planning to buy an engine and making some alterations this spring that will give a first class shop and equipment. Your paper is a big help to me as I am a long way from a first class man and I see a lot of little kinks in the paper which are quite valuable. I am also going in for auto repairing as every farmer in this locality owns an auto and more are coming.

Wm. Graham Jr., Canada.

He Started Early—I have been working at the trade since I was thirteen years old and I like it. We have the biggest and best equipped shop within a radius of 20 miles and get all the work we can handle. I do work on most anything that needs attention in the mechanical line such as gas engines, steam engines, automobiles, buggies, wagons and general smithing. We recently bought a welding outfit but have not used it yet.

We enjoy reading your paper and get many useful hints and schemes from it.

We have the prices the way we want them down here. The customer doesn't ask what the job will cost, what interests him more than anything else is when he can get it and knowing that labor is scarce and material costs high he doesn't kick.

George W. Braxton,
E. L. Braxton & Bro., N. Carolina.

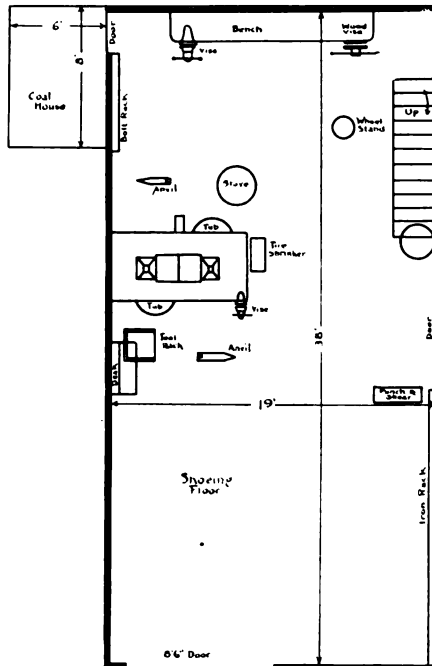

FLOOR PLAN OF MR. NEIL'S KEY-STONE STATE SHOP

How Do You Work H. S. Lathe Tools—I would like to have some of the brother smiths give their experience in working and tempering high speed steel for lathe tools.

C. E. Wilson, Ohio.

Our Only Fault.—Mr. L. P. Lacoste who conducts an auto repair shop in the Province of Quebec, Canada, tells us that the only fault he has to find with the Auto and Tractor Shop is that it is a monthly instead of a semi-monthly or weekly publication "for me it is the life of my garage and shop."

As Mr. Lacoste is located in a region having a considerable French population, his business stationery is printed in French and for the benefit of any who

want to know, "Automobile repairing and all kinds of mechanical work a specialty" is translated thus into French: "Specialite: Reparages d'Automobiles et Mecanique de toutes Sortes."

Was in the Famous 51st.—Mr. C. A. Ritchie, writing from his home in Scotland, tells us that he is busy getting his business organized again after four years service with the colors.

Mr. Ritchie was a members of the famous 51st Division, one of the finest divisions in the British army, bar none, and spent four years in the front line trenches as a signaller.

BE YOUR OWN CHAUFFEUR.

First—Blow the horn.

Second—To start, blow the horn, pull lever, blow horn, pull lever some more, turn steering wheel.

Third—To turn a sharp corner, blow horn, turn steering wheel to right; if this is not right, turn it to left suddenly. Blow horn again. Put on brake, take off brake blow horn.

Fourth—When meeting wide car in narrow road, blow horn loudly, depress starter, prime transmission, back her go forward, turn wheel, press foot on top button and blow horn.

Fifth—When going over rough roads, blow horn continuously, let on clutch, reverse, push foot brake, set lever at reverse, go ahead, blow horn.

Sixth—To stop the auto, blow horn, pull steering wheel, put on brake, cut in with muffler, shove down some of the brakes and blow the horn.

Seventh—To gain speed, blow horn first, step hard on the sparker, hold out right hand, blow horn again, release brake, advance starter, extend left hand and blow horn.

Eighth—Going down hill blow horn continuously, put on emergency brake, shift to low gear, reverse, retard transmission, when engine backfires, blow horn again.

Ninth—To go backward, blow horn, climb half way up steep hill, release brake and cut off engine, hold out both hands, blow horn and pray.

Tenth—To climb steep grade, blow horn, give her more juice, speed up accelerator, blow horn, turn wheel to left, to right, keep your eye in front, watch gauge, look behind watch both sides, keep your eyes on the sparker every minute and blow horn loudly.

—Haynes Pioneer.



A LAUGH IS NATURE'S BEST TONIC AND CHESTER CONKLIN ADMINISTERS THIS PANACEA FOR OUR TROUBLES IN "THE VILLAGE SMITHY", ONE OF THE FAMOUS PARAMOUNT-MACK SENNETT COMEDY PICTURES

AMERICAN BLACKSMITH AUTO & TRACTOR SHOP

VOLUME 18

MAY, 1919

NUMBER 8

BUFFALO, N. Y., U. S. A

Established 1901. Published Monthly at the Sidway Building, Buffalo, N. Y., by the

AMERICAN BLACKSMITH COMPANY

Incorporated under New York State Laws.

WILLIAM F. WENDT, *President.*

WALTER O. BERNHARDT, *Editor.*

SUBSCRIPTION PRICE:

For \$1.00 per year, payable in advance, The American Blacksmith, Auto & Tractor Shop will be sent, postage prepaid to any postoffice in the United States. To Canada, \$1.25; to other countries, 6 shillings. Reduced rates to clubs of five or more on application.

Remittances may be made by money order, express order or checks payable to the American Blacksmith Company. We will also accept uncanceled postage stamps or currency, but for safety these should be sent by registered mail.

Subscribers should notify us at once of non-receipt of paper or change of address. In latter case, give both old and new address.

Correspondence on all smithing subjects solicited. Always give name and address, which will be omitted in publishing, if desired. Address all communications to the

"AMERICAN BLACKSMITH COMPANY"
BUFFALO N. Y

Copyright W. F. Wendt Publishing Company, 1919 "

Cable Address: "Blacksmith, Buffalo"

LEGISLATORS AND LEGISLATURES



Farm Impt. News.

Somebody, we can't think of his name offhand, sagely observed once that "the best governed state is the least governed state" and Lord, how true it is!

We elect a man and send him down to the state capital to make laws—God save the mark—for us and no matter how good a fellow he may be ordinarily, he enters the legislature fully committed to a revision of all the laws from the Ten Commandments down to date and he goes into his first session primed and loaded with a few pet "laws" of his own stuck in his coat-tail pocket. A shining example of this particular brand of legislative imbecility is afforded by the bill in the Nebraska legislature appointing a committee to have authority to name the makes of tractors that may be sold in Nebraska.

Several other states—to be exact, Missouri, Oklahoma and North Dakota have passed or are considering similar March

Hare legislation affecting tractors that threaten the development of the tractor in those states at least.

History has a habit of repeating itself and this is only another instance of it for we still remember the same breed of legislator, inflated with the dignity of his temporary elevation and his title of "Hon.," entering the same legislative halls and inveighing against the automobile was responsible for a similar crop of restrictive legislation but such of it that has not been repealed has long since been forgotten.

OUR BLESSING ON THIS MOVEMENT

Garagemen of Minnesota have taken steps toward organizing a national association that will bring them closer to other organizations of the automobile industry.

The new National Automobile Repair Association will endeavor to obtain the cooperation of automobile engineers and designers of cars to the end that they may be constructed in such a manner as to be more accessible for repair, as the majority of cars are built so as to necessitate the loss of much time on the part of the repairman in correcting some minor fault and thereby involving unnecessary expense to the owner.

WHAT'S THIS WE HEAR OF TEXAS?

The Texas legislature has just passed a law authorizing the creation of private corporations for the establishment and maintenance of garages with authority to buy, sell, store, house, rent, repair and otherwise deal in motor vehicles, accessories, gasoline and oils. The bill also allows these corporations to operate motor cars and carry freight and passengers.

Why, we wonder, should an act of legislature be necessary to conduct a garage in Texas?

CONTENTS—MAY, 1919

| | |
|--|-----|
| Ignition, Starting & Lighting Systems..... | 185 |
| Repairing Fordson Tractors..... | 187 |
| Seasonable Talk | 188 |
| Uses for Empty Cans..... | 188 |
| Building a Garage Addition to the Shop | 190 |
| Tractor Hitches | 191 |
| Bushel Capacity of Wagon Boxes.... | 191 |
| "Hi Higgins is 'sold'"..... | 192 |
| Securing File Handles | 193 |
| Lincoln's Gettysburg Speech..... | 195 |
| Benton's Recipes | 196 |
| To produce bronze color on steel; Removing oil stains from concrete floors; Emergency boiler repair; To loosen pasted paper; Markin polished steel; Renovating auto tops. | |
| Shop Kinks | 116 |
| Two handy tools; Combination hammer; Circle or Gasket cutter; Unique open end wrench; Portable hoist; Light reflector; Cutting wire pins; Test centers; Collapsed radi- ator hose; Improvised heater; Forming pump leathers. | |
| Two Welding Jobs in One Fire..... | 198 |
| Piston Rings | 200 |
| Designing and Forging Tongs..... | 201 |
| Auto Body from Huge Tree Trunk.. | 201 |
| English Correspondence | 203 |
| For Sawing up Short Lengths..... | 204 |
| Ten Little Business Builders..... | 205 |
| Trade Association Open Price Policy | 206 |

DON'T GIVE MONEY TO AGENTS

The American Blacksmith, Auto & Tractor Shop DOES NOT employ subscription agents. Any person representing himself as such is an imposter and should be so dealt with. Notify us immediately if anyone claiming to represent this journal calls upon you.



"FORTUNES IN OIL."—The forest of oil rigs shows there are fortunes in oil for those right on the job and they are invariably the big oil companies, the fortunate owners of the property and—the stock swindlers that capitalize the fortunes of others that they may fatten on the unsuspecting and uninformed.

Read some oil stock advertising and see how vaguely and with what evident effort to mislead and deceive it is written and so long as no positive statements are made the swindlers are practically immune from any legal action. They don't claim "their" well is producing but they say that it is in the "same field", or "close", to some other well that is a big producer—no man's word is to be trusted when he advises the purchase of stock in any unknown or undeveloped proposition of any sort.

Ignition, Starting, Generating and Lighting Systems on Automotive Vehicles

C. L. WHITE

IN starting a discussion of Jump Spark Ignition principles it is best for the reader to realize at the start that in electrical things it is often difficult to explain and make clear in writing, those happenings and results which could very easily be demonstrated with the apparatus in hand. We will attempt to make our explanation of Jump Spark Coil (Induction Coil) action easy to understand by using everyday, non-technical language.

To begin with, the result we wish to obtain is a spark which will actually "jump" the gap between the points of the well known Spark Plug. This gap (see Fig. 1) measures a little less than 1-32", and can be gauged by the thinness of a dime that has been worn thin.

If it was simply necessary to create a pressure of electricity (voltage) that would push it across this small space in the atmosphere, the problem would be a comparatively easy one. But we must remember that this gap is located in the top of the cylinder-head (combustion chamber) where we have compressed gases, and also that these gases are moving at a high speed. This means that we must obtain a pressure of electricity that will cause it to jump this gap whether or no. It has been found, that, in order to do this, we must be able to get a spark that will jump at least 1/4" in the open air (outside the cylinder). It is better to have it able to jump 3/8", which is the usual test of sparking ability.

The voltage necessary to cause the electricity to jump this 3/8" is somewhere between 20,000 and 40,000 volts.

The Jump Spark or "induction" coil which accomplishes this result is really very simple in its construction. In the center of the coil is a core about 1/2" in diameter, made

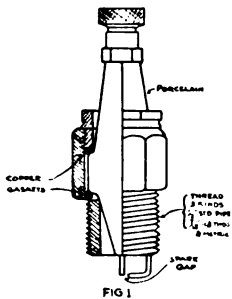

We're Beginning to Understand Why the Germans Quit

MR. WHITE was just in the midst of a series of articles on "Ignition, Generating and Lighting Systems on Automotive Vehicles" when Uncle Sam called him to do some special work in connection with the Committee on Education and Special Training of the War Department.

Almost the entire month of July, 1918 he spent at Camp Joseph E. Johnston, Jacksonville, Florida and in Washington, D. C., studying the problems of Motor Transport in the Army. In August he was sent to Purdue University, LaFayette, Indiana to organize and supervise the only Truckmaster School in the United States. This School was established as a part of the Student Army Training Corps but came under the direct control of the Motor Transport Training Department of the Committee on Education and Special Training, and was administered direct from Washington.

Special recognition was given this School when the War Department recommended and secured commissions as Second Lieutenants in the Motor Transport Corps of eight men who graduated from the first course. The only special training these men had had was secured in the Truckmaster School. Other applications were pending at the time the armistice was signed. The School was organized to train 900 men with 450 finishing each month.

Mr. White thus had the honor of having charge of one of the highest grade schools operated by the Committee on Education and Special Training.

Many of our readers will be glad to look up their last June and July issues of our magazine and thus refresh their memories on this very important subject which Mr. White handles in his own unusual way. Back copies will be mailed to those desiring them upon receipt of ten cents per issue, as long as the supply holds out.

up of soft iron wires bundled together. Around the core is a thin layer of insulating material, such as fibre or oiled paper. Outside of this is wound the "primary winding" which consists of about two layers of fairly coarse wire. So far it will be noticed, that we have a coil similar to the "kick coil"

mentioned in the preceding article (July, 1918.) When a current of electricity passes through this "primary winding" the core becomes strongly magnetized. Magnetic lines of force surround the entire coil, as shown in Fig. 2. The next step in making up this coil is to place around the "primary winding" the "secondary winding". This "secondary winding" is made up of a large number of turns of very fine copper wire.

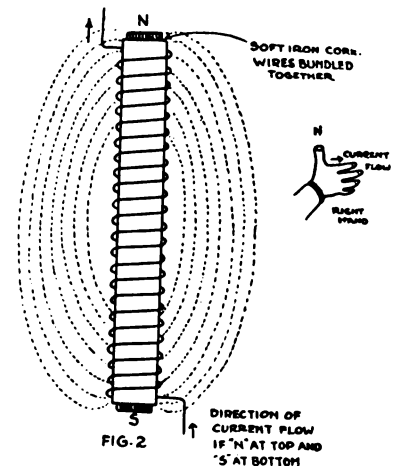

(usually about No. 36). This wire is about the size of a horsehair, and is insulated. Not only is the wire itself covered with insulation, but the different layers of wire are separated by oiled paper. This makes it very sure that the electricity passes through the wire, and does not take any short cuts.

It will now be noticed that the turns of the "secondary winding" pass through the lines of force of the magnetic field. Figure 3 shows, in a diagrammatic way, just how the "secondary winding" surrounds the primary. Now, we come to the principle of operation of this coil. We have found that a magnetic field is a good place to harvest electric current. One must have, however, the right kind of a rake and the proper path over which to conduct the harvest (electricity) to the place where it can be used. In this case, the rake is the "secondary winding". The path is the wire to the spark plug which is the place where it is used. Before the

magnetic field can be harvested into the secondary the crop must first be cut down. This is accomplished by "breaking" the primary current and so killing the field, thus setting up a current of electricity in the "secondary" winding, which acts as a "rake" and gathers it up

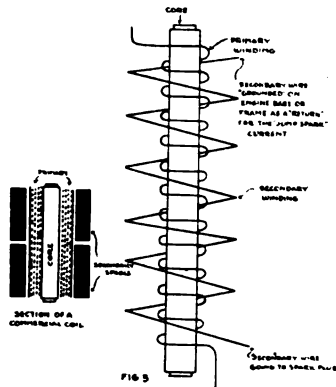

in its many, many turns and delivers it thru the secondary wire to the spark plug.

The hard thing for many people to understand is the fact that the electricity does not actually flow from the primary direct into the secondary but as the electrical engineer says, it is "induced" in the secondary.

It seems to me that it will be easily understood if we imagine that the "primary" winding "sows" the magnetic field around when the battery current flows through it. We then cut down this harvest by "breaking" the primary circuit (stopping the current flow) which "cuts down" the magnetic field which the "secondary winding" rakes up and harvests. As one gets more grain at the harvest than he sows, so the secondary has higher pressure (voltage) than did the battery current in the primary. This last comparison is not a very good one, altho it may help to remember the point, because what the secondary has gained in voltage it has more than lost in the quantity of current flowing (amperage). As it is the high voltage we are after to make the current jump the gap of the spark plug under all conditions, we do not mind the loss in amperage.

The next device we need to understand is that which "breaks" the primary circuit. There are two kinds of devices that accomplish this,—the vibrator, which breaks the circuit a number of times in succession, the device being located

on the end of the coil; and the simple "breaker" or "timer" which breaks the circuit just once for each spark that is need at the spark plugs. This "Breaker" is operated mechanically and is located on the engine.

We will first describe the operation of the vibrator. A simple illustration of a typical vibrator is shown in Fig. 4. A block, B, is screwed to the top of the coil box. To this block is attached a flat steel spring, A. At the outer end of this steel spring is a small iron button, C, which is located just above the end of the core of the coil, G.

Just above the steel spring is an adjustment screw, E, held rigid by a yoke or bracket, F which is attached firmly to the top of the coil box.

It will be noticed that the bottom end of the adjusting screw, E, has a little button to it. This is made of some kind of alloy, either of platinum or steel. A corresponding button is riveted into the steel spring, A, and the "breaking" of the primary circuit occurs when these little platinum "points" (or steel alloy "points) separate. The separation is brought about by the attraction of the core, when magnetized, for the iron button, C. Of course, as soon as this iron button is drawn downward it draws down the flat steel spring, A and separates the breaker "points", thus killing the magnetism in the core, releasing the pull on the little iron

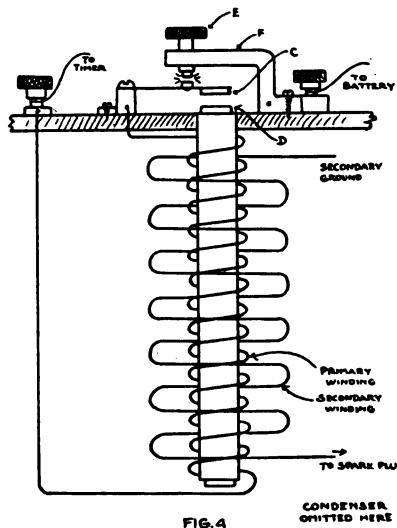

FIG. 4

button and the flat steel spring brings the points back together again. This action is similar to that which causes the common door bell to ring. The reader will have to follow through this explanation

very carefully unless already familiar with this action.

The action of the Condenser will be described in a later article, watch for it.

LIQUID AUTO BODY POLISH

The constant washing of automobile bodies with soap and water deadens the polish and similarly the ingredients used in the paste polishes have a destructive effect on varnished surfaces, usually resulting in cracking and checking of the varnish.

A number of liquid body polishes are on the market selling for fancy prices and the following formula and directions are for the preparation and application of a liquid body polish that is exactly similar in composition and method of using to those on the market.

- White Mineral Oil.....1/2 Gallon (Neutral Specific Gravity 29°)
- Gasoline1/2 Pint
- Oil of Wintergreen, Cedar or Sassafras3/4 Ounce

The gasoline is poured into the white mineral oil, small quantities at a time, stirring the solution constantly while adding to insure the thorough incorporation of both ingredients. Next stir in the oil of wintergreen, sassafras, or cedar as preferred to give a pleasing odor to the mixture.

The best results in the use of this preparation are obtained by applying it with an atomizer or hand spray pump of the type that are used for spraying liquid insecticides and can be obtained at most department, hardware or seed stores.

After spraying the preparation on the body of the car in a thin coat, the surface is then polished by wiping with clean cheesecloth.

The ingredients are inexpensive and can be obtained from your local druggist or he can obtain them for you through his jobber. Any wholesale druggist has these materials in stock.

A time saver in putting a bolt through the rear spring on a Ford car is to cut a hole about 3/4 in. in diameter directly over bolt head. The broken one can be forced up and out and new one put in its place without taking the spring out from under car. In cutting hole above bolt leave about 1/4 in. stock to act as hinge. After new bolt has been installed, then bend it back to its original position, clean both edges and drop a few drops of solder on, making a neat finish.

Repairing Fordson Tractors

J. L. HAKY

SOONER or later someone is going to have a job fixing up something or another that has gone wrong with a Fordson tractor or install new parts and in preparation of that time it is the purpose of this article to give a few pointers on the subject.

Removing the Motor from the Transmission—Should it become

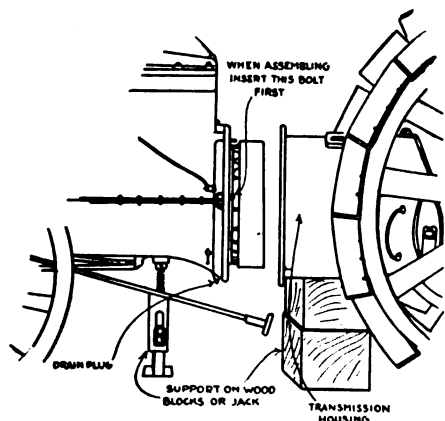

SEPARATING MOTOR FROM TRANSMISSION

necessary to tear down the motor for repairs or adjustment it becomes necessary to do the following;—drain oil from motor; open drain cock under radiator and drain water from radiator and water jacket; close stop cocks on sediment bulb and gasoline tank and remove gasoline tank; disconnect steering arm from drag link and control rods from the vaporizer and commutator; remove the dash by unscrewing the four cap screws that hold it to the transmission housing; jack up the transmission housing and the motor separately being careful to place a wedge on both sides between the cylinder front cover and the front axle to keep the motor from tilting over when it is disconnected; remove bolts from the cylinder flange holding motor to transmission housing, the rear of the tractor can then be drawn away from the motor as shown in the illustration.

When reassembling the tractor care should be taken to see that the two bolts, one on each side of the cylinder flange and just above the crank case, as shown in the picture, should be inserted first.

The bolt holes are a trifle smaller than the others and being reamed accurately they bring the two parts into correct alignment and no difficulty will be experienced in placing the remaining bolts.

In disassembling the tractor care should be taken to prevent the paper gaskets from being torn and if they become damaged they should be replaced with new ones. Many of the gaskets on the Fordson are made of paper and new ones can be made from ordinary newspaper. When fitting a new gasket it is best to shellac one side with shellac. The gasket will then stick to one surface and will not be so liable to tear when the joint is taken apart.

Removing Rear Axle Assembly—Drain the oil from the transmission housing; jack up rear end of tractor and remove rear wheels; remove the twelve cap screws from each of the rear axle housings and draw them off and the rear axles and the differential can then be

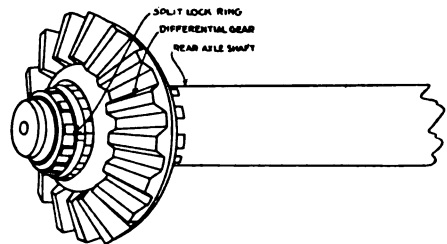

REMOVING DIFFERENTIAL GEAR

lifted out in one unit as shown in the illustration. The worm wheel and the differential housings can then be taken apart by removing

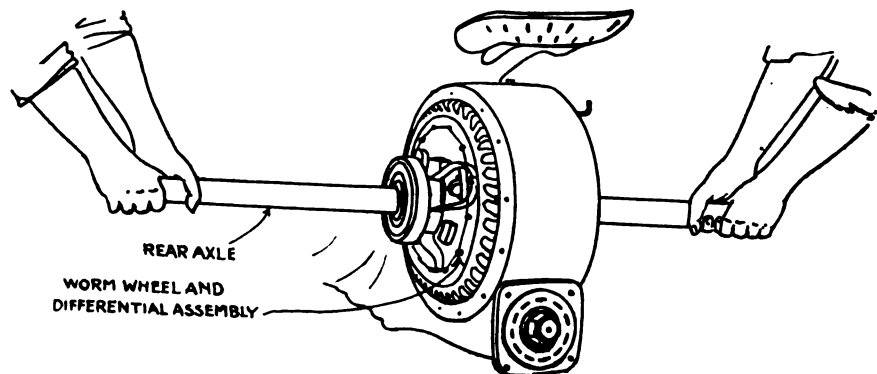

REMOVING REAR AXLE ASSEMBLY

the twelve bolts that hold them together.

Removing Differential Gear from Rear Axle Shaft—Press the gear back along the shaft until the

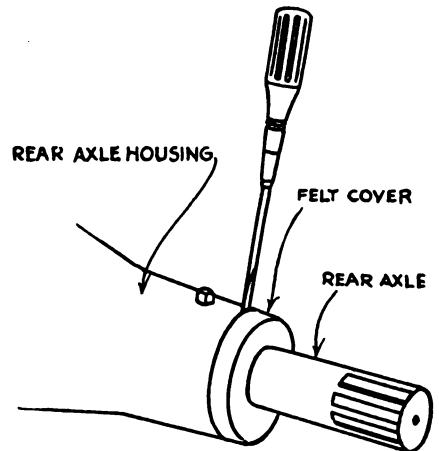

REMOVING REAR AXLE FELT AND ROLLER BEARING

split locking ring is exposed, as illustrated, remove the ring and press the gear off the shaft. An arbor press or some satisfactory makeshift must be used for this purpose and, NEVER attempt to drive them off with a hammer.

Removing Rear Wheels — The rear of the tractor is jacked up and the four bolts are removed from the hub with a box wrench and bar that is included in the tractor tool equipment. If this is not at hand other means will be found necessary. Then insert two of the bolts in the threaded holes of the rear wheel bushing, as shown and tighten up these bolts evenly until the wheel is free on the bushing. Apply the hooked end of the bar to the

flange and force the bushing off the axle. When replacing the wheels, four screws are inserted in their respective holes and tightened up equally, the ends of rear axle being kept flush with the outside of the bushing.

Care of Rear Axle Roller Bearings—The roller bearings at each

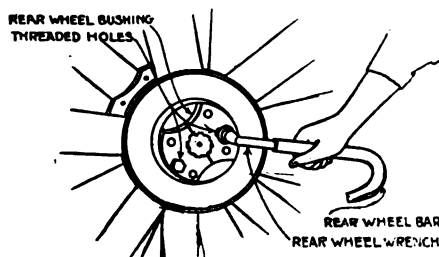

REMOVING REAR WHEEL

end of the rear axle housing should be kept well lubricated by occasionally removing the plug shown in the illustration and inserting heavy fluid gear oil. The felt washers that protect the bearings from dust and dirt should be replaced with new ones when badly worn or dirty. To do this the rear wheel is removed as well as the steel cover on the end of the housing and this is removed with a screw driver as shown. When replacing the felt washer, the edge should be bent into the groove in the end of the rear axle housing to keep it from coming off.

SEASONABLE TALK.

George H. Murphy

A question we often hear in the spring is, "What shall I do with my car before I take it out and run it." Perhaps this question is not clear but the men that ask this question are men who have had their car overhauled wholly or in part and have their car in their own garage and covered up for the winter, the chances are that the car has not been uncovered or the engine started all winter and the owner does not know just what to do before he starts running for the summer.

We will assume that the car has been looked over and there has not much been done to it. The owner took the car home, jacked it up on home made jacks the storage battery removed and the tires have been taken off. The first thing that should be done is to clean the rims where the tires go. Take an old file and scrape the rust from the rims where the tires go. Take an old file and scrape the rust from

the rim after which take coarse sandpaper and smooth them some more. Take a cloth and wipe all the dust off and give them a thin coat of shellac or rim paint. This will make it much easier remove the tires when trouble occurs on the road. Don't forget the spare rim when doing this. The rims should dry at least a day before putting on the tires.

Use a good deal of care in putting on the tires. If there are any cuts in the outside rubber they should be filled with any of the good plastic fillers on the market. This is the only time that this does any good, I think. I have seen men drive their cars into the garage at night and look their tires over for cuts and fill them with this cut filler and I do not believe that it would stay in as long as it took them to put it in for the reason that the cut would be damp and rubber will not stick to a damp surface. But after a tire has been off all winter it should be good and dry and it will stick in good shape and keep the water out. It is dampness in these cuts that do the damage for dampness rots the canvas. Test the tubes before they are put into the casings. Pump them up good and full but not enough to burst them and hold them under water a section at a time and if there are any leaks you will see the bubbles rise to the surface. After the tires are on pump each one up to the pressure the maker recommends, or nearly so, if it says on the tire, to inflate to 80 pounds, I think that 75 pounds is enough. It is a good idea to own a tire gauge and us it. Just because a tire looks as if it was up to pressure is no sign that it is. A good rule to go by in inflating tires is that they require twenty pounds for each inch in diameter, so that a three inch tire will require sixty pounds pressure. Of course, if the car is a runabout and always carries a light load they need not be pumped up quite as full. Do not think that a hot day makes more pressure in a tire for it makes but very little difference. The reason an old tire goes up on a hot day is that the road surface is hot, the old tire gets hot, the different layers separate and the casing cannot stand the strain.

Now that we have the tires on and pumped up to pressure we will look at something else. The storage battery will be next in order for we may want to use the trouble

lamp to look at other parts of the car. Now, the battery has been to the service station and of course it it all right and all we need do it to scrape the terminals with our knife so that they are bright, also the tapered holes on top of the battery. Before putting them in spread in a thin coating of vaselene or cup grease, to prevent them from sticking and they can be removed without breaking the battery next fall.

If the battery has not been to the service station but has been in the cellar all winter it will be another story. The chances are that it will not test very much, even if you have kept the plates covered with distilled water. The best thing to be done is to give the battery a fifty-hour charge at a four-ampere rate from an outside source. After this it can be replaced in the

USES FOR EMPTY CANS.

There are always plenty of empty tin cans of all kinds to be found about the place, and if one cares to use them for smallware, bolts, nuts, pins, screws, etc. they can be quickly made into handy receptacles as shown in the sketches. Round cans are generally cut open

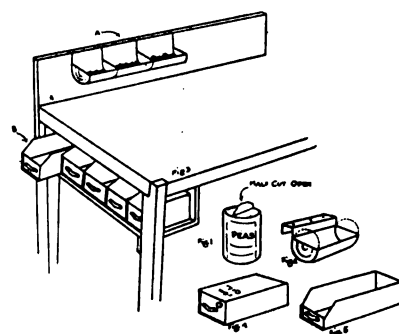

about like shown in the sketch Fig. 1. By cutting down one side and across the bottom the handy bench containers can be made, as shown at Fig. 2, the cut side being bent back to form a hanger. These placed along the bench on the back board, as in Fig. 3, A, make excellent small trays that have no square corners and are easy to pick things out of.

Figs. 4-5 show how one gallon oil or varnish cans can very easily be made into drawers to set on a shelf at the end of the bench, as shown at B. To make them calls for simply cutting out one of the wide sides and cutting diagonally down each of the small sides and across half of the top, as in Fig. 4.

car. After the first trip the battery should be tested and the hydrometer should register from 1.275 to 1.300 if the battery is fully charged. If at any time during the season there seems to be water coming out of the battery box, or one cell seems to always be down on water, the battery should be taken apart and looked over for this denotes that one or more of the jars are leaking and should be replaced.

After the battery has been installed and all connections made the starter button should be pressed down gently to see if the starter is in working order, the engine need not be started. Snap on the light switch and see if the lights come on as they should. If the bulbs are black they should be thrown away as they do not give much light and waste current. The lenses should be cleaned on the inside and the reflectors should be dusted off. Do not try to polish the reflectors with metal polish or wipe them with a dirty rag. First, blow out the dust with an air hose or a bellows, then wipe them out with a small piece of absorbent cotton dipped in alcohol. In doing this wipe the reflector with a motion from the bulb to the rim of the reflector. Great care should be used in cleaning these reflectors as they are very highly polished and scratch easily and after they are badly scratched they do not throw the light as well.

You know that one can not always depend on what the garage man tells you any more than you can on what the butcher says. You ask the butcher if a piece of meat is tender and he will tell you that it is even if it's so tough the dog can't eat it. The same applies to the garageman; you ask him if he greased the front wheels or filled the transmission and he will say he did, but maybe he thought he did. The only way to be on the safe side is to look and see. Of course one dislikes to do work over after paying a man to do it but for your own safety it will be best to remove the hub caps of each front wheel and see that there is new grease in the bearing and that the adjustment is tight enough. With some types of hub-caps, they can be filled the same as a grease cup and then turned on and the grease will be forced into the middle of the hub and out around the inside bearing. The cap may

have to be filled a number of times before the grease will come out, but after the inside of the hub is once filled it will not take much to grease it the next time.

Most all transmission cases have a plug that can be turned out when the transmission needs filling, but the opening is so small that one cannot see down into it to see if any grease or oil is needed so the best way to do is to take the cover off. This can be done by taking off a few nuts or bolts and in replacing the cover see that the gasket is in place, so that the grease will not leak out and run over everything. The cover on the differential case should be taken off so that one can

the part that they are supposed to grease will get greased in good shape at the beginning. If there are any oil cups these should receive a generous amount of oil. The brakes should be tested to see that they have been adjusted properly.

Now, that we have gone over the car pretty well it will be a good plan to fill the radiator with water and start the engine. Do not race the engine first because it is stiff. After the engine has run long enough to get the water in the radiator warm it will be a good plan to take the car out and see how it works. See that the battery is charging at the rate it should and see that the engine pulls in



THE GARDEN TRACTOR EARNS ITS "KEEP"

see how much grease is needed. The amount of oil or grease needed in the transmission is about up to the middle of the lower shaft. If the two shafts are side by side have the grease half way up on the gears. Do not fill higher than this as it will run out at the bearings. It depends some on the make of car how much to put in the differential. Most cars have a plug that is at the right height on the case, so that it cannot be filled any higher than this plug, but on some cars this is too high. If it is too high it will run out at the wheels and cause trouble in the brakes.

The old oil has no doubt been drawn out of the engine base, but if there is any doubt about it, the plug should be turned out and the oil drawn out and some kerosene poured in and the engine started and run a few minutes the kerosene drawn out and new, clean oil put in.

Some cars have one or two universal joints that need filling with grease. If you have a car that has a universal composed of two discs of leather, you are lucky as they will not need grease. There are usually a number of grease cups and these should be filled a number of times and turned down so that

good shape. The car may not show up on power the way it did last summer but you must remember that the bearings are up tight and the roads are not as good as they are after they get good and dry in the summer.

Usually after the brakes have been relined and taken up, after about one trip they will not hold very well and will need taking up again. The reason for this is that the lining does not fit the band as the old lining did and after using them a few times it causes the lining to fit the band and takes up all the adjustment. If anything is not right when you try out your car in the spring take it back to the man that overhauled it and tell him the trouble and he will usually be glad to put it right.

One more thing, do not forget to fill the oil and grease cups again during the summer and turn them down. Some men think that if they are filled once that is enough, but it is not so, they need filling quite often and should be turned down once or twice. In wet muddy going it is a good plan to turn them down until you see the grease coming out. This forces out the mud and keeps mud and dirt from getting in where it shouldn't be.

Building a Garage in Connection with the Repair Shop

JOHN Y. DUNLOP

THE building of a wayside garage near a business center is a very good idea where an extension of business for the repair shop is under consideration. Not only does this add much to the yearly income but it provides facilities for general overhauling which means more work and also more money for the motor repairman.

The great difficulty in many cases is to obtain sufficient land adjoining the shop. Of course many auto repair shops have open spaces adjoining but I do not favor open spaces as both the workmen and the cars should be under cover.—Men do not like to work in the rain nor do they enjoy working under a blazing sun. What is wanted is an enclosed building with ample side light and that will be comfortably warm in winter and reasonably cool in summer.

With a building such as this, ample return can be had from the storage and towing business without consideration of the side issues such as the sale of gasoline, lubricants, tires and other accessories and necessities and of course a garage such as this must possess all facilities for business.

In the first instance the building should be so arranged that cars may be run in and out of the building with a minimum of effort and Figures 1 and 2 show two arrangements.

The first one has a separate door for the entrance to the garage and which is on the same side of the building as the repair shop entrance. Between the garage and repair shop is the office and on the opposite side is the store which might also be used as a stock room, tool room or foreman's room.

Practically the same arrangements is adopted in Fig. 2 only the office is just clear of the entrance to the garage. Where the space is limited Fig. 2 is the most suitable as less supervision is required as all cars must necessarily pass through the repair shop. There is this dis-

advantage however, that the entrance takes away a bit of the floor space of the shop and at least any work which may be on that part of the floor might have to be shifted to let a car in or out of the garage.

The gasoline pump is in both cases near the office and thus the person in charge can check the amount of gasoline sold as the cars go out.

The space for washing cars, or the wash "rack" as it is generally called is well out of the way, as it should be, in both plans and only in Fig. 1 would any cars have to cross this part of the floor in passing to and from their quarters. This part of the floor should be made of concrete with the surface sloping toward the drain in the center should of course be connected to an outside drain.

Each plan provides a working pit which should be built of brick or concrete and provided with a drain to carry off any water that might find its way in. The pit is not an absolute necessity and as a matter of fact it is not often found even in large garages and repair shops.

One of the most important things to consider is that the cars should have easy and unobstructed

is a large one and the building is of sufficient breadth then the simplest plan is to arrange the cars on each side and the stalls can be arranged so as to form an angle to the longitudinal axis of the building and pointing toward the door which should preferably be in the end of the building and in that case the wash rack would be best located at the rear of the building. Possibly in a plan such as that the office and store would adjoin each other and the office could have a separate outside entrance.

Another feature which should receive some attention is the matter

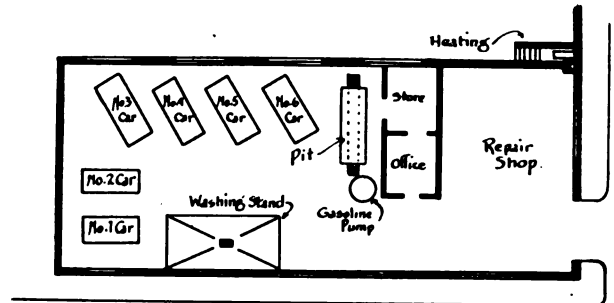

FIG. 2.

of ventilation. Exhaust gases and smoke from gasoline engines are deadly and in some cases more or less explosive so that suitable ventilators should be provided on the roof.

All garages should be heated in some manner in winter and possibly the most convenient arrangement is the low pressure hot water system and this should be placed in such a location that it could not cause fire. Heat prevents rust and frozen radiators, as well as enabling men to work in comfort.

Proper consideration should also be made for the toilet conveniences of yourself and your patrons and the cleaner and neater this place is kept the better the impression will be. There are numerous other things that one might suggest but for the present will be passed by.

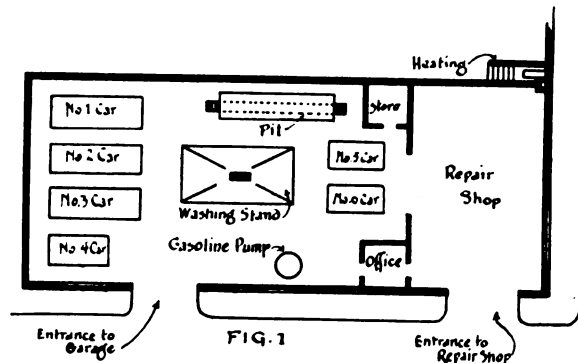

FIG. 1

access of entrance and exit. In many cases the time lost in shifting cars is appalling and bothersome. An easy run in and a complete arrangement of stalls with as much space as possible between is what is desired. If the building planned

Now is the time to urge the farmer to sharpen plow points and discs and to touch up the dull harrow teeth. Cultivator shovels also should be put in shape. Dull tools cannot do satisfactory work. It is a good practice in the case of spike tooth harrows to reverse teeth in their clamps when worn only on one side, but if both points are dull, resharpening by forging and retempering will probably be necessary.

HELPS FOR THE VULCANIZER

Vulcanizing cement that becomes thick through the evaporation of its solvents can be thinned to any consistency with gasoline.

Scraps of uncured rubber stock that accumulate about the vulcanizing department can be converted into a thoroughly satisfactory and high grade air drying rubber cement by placing it in a tightly covered container and pouring gasoline over the rubber scraps. Cutting the scraps of rubber in small pieces will hasten the dissolving of the rubber. A small quantity of alcohol may be added to reduce the dissolved rubber to a perfectly smooth mixture and to reduce any tendency to lumpiness that may exist.

Small quantities of alcohol may be added to vulcanizing cement for the purpose of reducing lumps but it should be used very sparingly as it has a tendency to cause blisters. Only uncured rubber can be dissolved.

BUSHEL MEASURE CAPACITY WAGON BOXES

| Size Box | | Wt. per bu. | Corn on Cob 70 Lbs. | Corn, Shelled Rye & Flax- seed 56 Lbs. | Wheat Beans and Peas 60 Lbs. | Oats 32 Lbs. | Barley 48 Lbs. | Irish Potatoes 60 Lbs. |
|----------|-------|-----------------------|------------------------|---|---------------------------------------|-----------------|-------------------|------------------------------|
| 18" | 9'6" | No. Bushels | 18 | 32 | 32 | 32 | 32 | 25 |
| | | Weight Lbs. | 1260 | 1792 | 1920 | 1024 | 1536 | 1500 |
| 20" | 10' | No. Bushels | 21 | 38 | 38 | 38 | 38 | 30 |
| | | Weight Lbs. | 1470 | 2128 | 2280 | 1216 | 1824 | 1800 |
| 22" | 10' | No. Bushels | 23 | 42 | 42 | 42 | 42 | 33 |
| | | Weight Lbs. | 1610 | 2352 | 2520 | 1344 | 2016 | 1980 |
| 24" | 10' | No. Bushels | 25 | 46 | 46 | 46 | 46 | 36 |
| | | Weight Lbs. | 1750 | 2576 | 2700 | 1472 | 2208 | 2160 |
| 22" | 10'6" | No. Bushels | 24 | 44 | 44 | 44 | 44 | 34 |
| | | Weight Lbs. | 1680 | 2464 | 2640 | 1408 | 2112 | 2040 |
| 24" | 10'6" | No. Bushels | 27 | 48 | 48 | 48 | 48 | 38 |
| | | Weight Lbs. | 1890 | 2688 | 2880 | 1536 | 2304 | 2280 |
| 26" | 10'6" | No. Bushels | 29 | 52 | 52 | 52 | 52 | 41 |
| | | Weight Lbs. | 2030 | 2912 | 3120 | 1664 | 2496 | 2460 |
| 28" | 10'6" | No. Bushels | 31 | 56 | 56 | 56 | 56 | 44 |
| | | Weight Lbs. | 2170 | 3136 | 3360 | 1792 | 2688 | 2640 |
| 22" | 12' | No. Bushels | 28 | 51 | 51 | 51 | 51 | 40 |
| | | Weight Lbs. | 1960 | 2856 | 3060 | 1632 | 2448 | 2400 |
| 24" | 12' | No. Bushels | 30 | 56 | 56 | 56 | 56 | 43 |
| | | Weight Lbs. | 2100 | 3136 | 3360 | 1792 | 2688 | 2580 |
| 11" | 10'6" | No. Bushels | 12 | 22 | 22 | 22 | 22 | 22 |
| | | Triple Weight Lbs. | 840 | 1232 | 1320 | 704 | 1056 | 1020 |

It is better to use the words "tractor business" instead of "tractor game," and instead of saying "tractor expert" to use the words "practical man." These may seem unimportant features, but it has been found that their psychological effect upon the farmer is surprising.

Everything possible should be done to put the tractor business on a substantial business-like footing where it belongs, and to dispel any illusion the farmer may have that it requires an expert to operate a tractor.

Various Implement Hitches for Use With Tractors

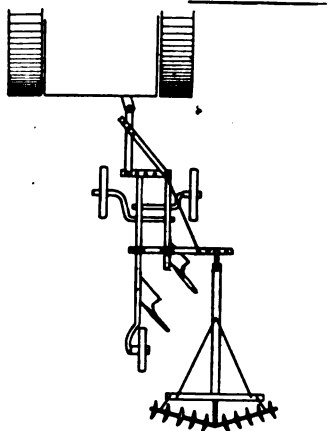

HITCH FOR TWO PLOWS AND DISC

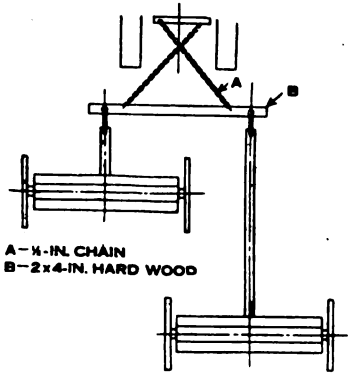

A-4-IN. CHAIN
B-2x4-IN. HARD WOOD

HITCH FOR TWO DRILLS OR DISCS

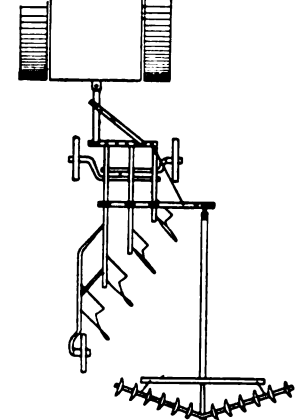

HITCH FOR FOUR PLOWS AND DISCS

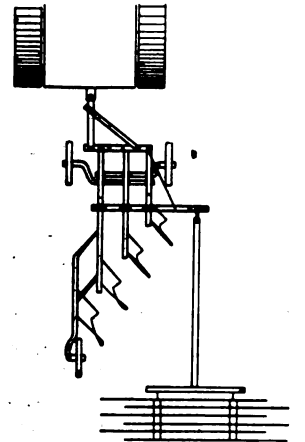

HITCH FOR FOUR PLOWS AND HARROW

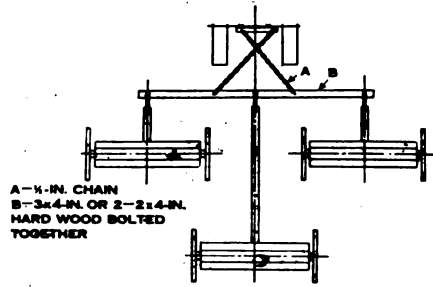

A-4-IN. CHAIN
B-3x4-IN. OR 2x4-IN.
HARD WOOD BOLTED
TOGETHER

HITCH FOR THREE DRILLS OR HARROWS

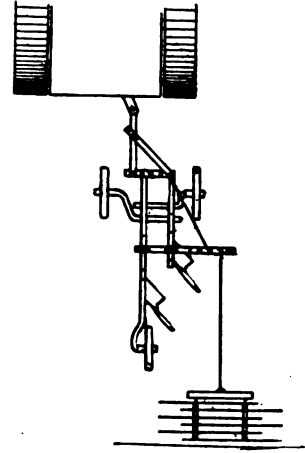

HITCH FOR TWO PLOWS AND HARROW

"Hi Higgins is 'Sold'"

So writes Uncle Jiminy Cricketts

I c'n well remember the time when Mirandy and me went to Allen County Fair the year they fust showed the gasoleen buggies.

"You'll never get me ter ride in one o' them pesky things," says Mirandy. "You take y'r life in y'r hands—temptin Providence, I'd call it," she added, when one of them started up and went snortin' and puffin' in an oncertain kind o' way down the race-track.

Of course it might seem like I was gettin' immodest ter brag about what happened so long ago, but I sez to her sez I—and this shows y'r how up an' comin' I allus wuz—I sez, "You'll ride in them right common afore ye die, Old Girl," I only call her "Old Girl" when I realiz' my superiority but when she needs correction I allus call her plain Mirandy.

Gosh! how things hev changed since that Fair! Mirandy can crank up the bus herself—when the starter ain't workin' and that's most often as I ain't got onto them things yit—and as I wuz sayin' she cranks up herself and goes flyin' over t' the Forks or Skinnerville an' like as not when she gits back she brags about makin' "Jabe Slocum take her dust" all the way over an' him drivin' that red contrapshun he calls his "racer" too. And Mirandy killed one o' the neighbors' chickens last summer too. I ain't goin' to say which neighbor it wuz as they might read this and y'know how things do git about these days'n how easy it is to offend some folks. Ther's lots of 'em aroun' these parts as takes the Auto & Tractor Shop.

But here I be off the road. I promised to tell you about Hi Higgins an here I been talkin' mostly about Mirandy. We ain't been married only thutty-two year come next May an' I stil rave about 'er at times.

You all know Hi Higgins—lives over beyon' the Forks some three mile down the river road—house once was painted white but it don't show much now. Green blin's left on some o' the winders too an' seems t'me the barns look as if it once saw some red paintsomewhere.

Hi's gran'dad, Old Eph Higgins, built the place, brought his young

wife there when she was a bride. House has lots of closets, they say; one in ev'ry room. She wanted lots of room f'r her clothes—she prob'ly thought she'd get lots after she wuz married, poor thing. Far as I c'n find out Old Eph never bought her any. The old cuss was as stingy as—as a man who won't buy gas f'r his auto on a pleasant Sunday with the tires all good—he wasn't stingy with children tho'—they had eight, spaced about two years apart.

When Old Eph died the children had a great scrap because he left all his money—some say five an' some say fifty thousand, so who c'n say—to his son Henry. Henry was Hi's father you see. The old man knowed Hen was as "close" as the bark on the tree while all of the others couldn't hev kep' the money over night.

I don't believe Old Hen ever touched the principal an' there are some who say he didn't allus draw the interest either—just let it be pilin' up in the bank. So, you see, when Old Hen Higgins died that left the whole bizness to Hiram—we all call him Hi for short—and Hi, being just as "near" as his dad an' gran'dad, still has the whole thing, him bein' an only child, beside a sister who died when a baby.

SPRING LEAF SPREADERS

There have been many auto and truck springs broken by attempts to spread the leaves of the spring apart with a hammer and chisel when graphiting them. To avoid

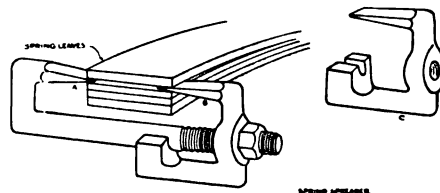

this, one can easily make the simple leaf spreader shown in the sketch. The material is obtained by cutting the heads off a couple of suitable machine steel bolts and forging them up to the shape indicated and hardening the wedge tips A, B. The cross head is shown in detail at C.

There now, you have it all down t' date, except that no one's ever been able to get Hi to buy any new farm machines—"new fangled contraptions" he calls 'em,—no, he'll never buy 'em until they've been used f'r ten years or more.

Never would put a pump in the house, so his wife lugged all the water for washin' an' the kitchen until las' year when he walked in Jake's place down to the Forks an' told him to "send him up a pump with the pipes an' things,"—just like he wuz buyin' a rake or a can of Paris green.

Queer feller, Hi; some folks call him odd. He'd be a good one to join that city club I hearn about down to the Grange meetin' last week,—Odd Fellers, I believe they call 'em.

Well, now, to get down t' the gist of this 'ere yarn—Hi met his Waterloo las' week. Yes, sir, he was sold good an' proper,—an' by the littlest city cuss y' ever seen. A young feller wearin' a gray suit with a red necktie, an' slick as a whistle with his hair combed straight back like a porkypine runnin' fer cover. Y' see this is how I happened to know about it I was drivin' home by the River Road that passes Hi's place comin' back from Mirandy's sister Annie's place near the Junction, an' as I come up over the top of that little rise jest afore ye get to Hi's yard the fust thing I saw wuz a gasoline tractor with red wheels and a green body. So you see I wuz right on the ground an' can speak the facts—no hearsay to what I'm tellin' yer.

An' this young feller I mentioned—I disremember his name, and it was told me too,—this chap was askin' Hi which field he wuz goin' to plow next. I couldn't hear all that wuz said because I'd jest stopped my engine—it makes so much noise when y' want to listen—y'know.

An' Hi, sort o' bewildered like with that green an' red thing right in his dooryard, sort o' waved his hand to'rds a strip of about ten acres of sod that laid between his pertater piece of last year an' the road.

An' what do you think that feller did? Druv right thru the gate before Hi could get his breath to stop him dropped down a couple o' plows that hung on the back o' that tractor an' went down that field like mad. The sod wuz turnin' jest

as slick as if it always did want to be t'other side up.

Well, Hi jest stood an' looked with his lower jaw restin' on his chest. An' then, at first by the look on Hi's face I thought that young feller'd never git out o' that field alive. But the longer he looked the softer he seemed t'get an' then he broke into a roar that could've been heard a mile, I bet. It sounded just like Hi did once when the fellers down t' the Forks got him to take too much of that "sweet" cider they had there and he got real jubilant. The fellers allus swore that it got old after he'd drunk it. I allus had my opinions about that tho'. You can bet I was some glad Hi had begun to see the humor of the situation as I didn't hanker t' be a witness to any murder.

In considerable less time than it takes t' tell it that young feller made a couple of turns around' the place, stopped in front of the gate, shut off the engine, climbed out of that tractor an' come runnin' over to where Hi wuz still standin'. "Now, we'll see some fun," sez I to myself as I cal'lated that Hi would order him outen the field instanter.

"How's that for plowing, Mr. Higgins," sez this young feller. "You can't afford to be without that tractor another day. It don't eat its head off when it isn't working, and will pay big interest on the investment."

"It don't do bad, sure enough" sez Hi, an' I nearly fell off my seat.

"Better take it while it's here," sez the young feller. "There's a great demand for them and you may not be able to get another this season."

"Don't know but I'll take 'er," sez Hi. "Ain't got the money home though."

"Oh, that's all right" sez the young feller, noticin' me for the first time. "Here's a fellow here headed toward town. Can you give us lift?" he sez, speakin' to me.

"Sure" sez I, "allus glad to accommodate. Git in."

An' so I took 'em down to town an' seen the deal entirely fixed even to arranging for Jabe Slocum to go over with Hi and teach him all about his gasoline hoss.

An' then when I got home an' wuz thinkin' the thing over I told Mirandy, sez I, "Now if Hi Higgins is really waked up he'll go buy a washin' machine for that there wife

of his an' stop some of her back-achin' scrubbin'."

"Yes," sez Mirandy, "and put in a furnace in that old house so she can take some comfort in the winter, wimmen like warm houses, you know."

An' then I adds, "If he'll jest put in one of these electric light plants like our'n he'll be able to read an' enjoy the Auto & Tractor Shop in the evenings because you see now that he's got that tractor he'll get his work an' chores done up earlier and so much easier that he won't have to get to bed right after he's through." And Mirandy agreed with me.

SECURING FILE HANDLES

The two kinks shown will be appreciated by those who use files, for who has not been bothered with the handles loosening, coming off, and getting lost. The means used to secure the handle to the file in Fig. 1 is simple and effective. A small pointed screw is put in the body of the handle, as indicated by the dotted lines. The tip of this screw engages into a Vee slot ground with the edge of the emery wheel into the tang of the file, as shown at A. When marking the tang for the slot, it is first put in the handle and the screw worked

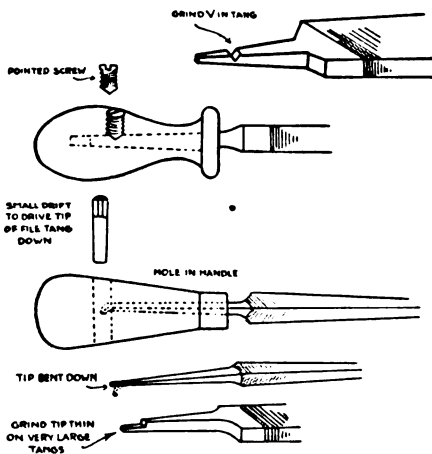

down on it a couple of times to mark it, then it is removed and the slot ground.

Fig. 2 shows a very easy way to make sure of the handle staying on. A small hole is drilled through the body of the file handle (1-4 inch hole) and then the tang of the file is ground thin at the tip as indicated at A. The file is put into the handle in such a way that this thin tip of the tang can be bent down into the hole by a small round drift, as

shown by the dotted lines. When it is desired to take the handle from a worn file the bent tip is driven back to allow the file to be withdrawn.

AUTOMOBILE RADIATOR CEMENT

If you buy a small can of radiator cement for stopping up small leaks in the radiator you pay from 50 to 75 cents for it—if you make the same preparation yourself, either for your own use or for selling it to your patrons it costs less—considerably less and the preparation and the results are the same.

Here's how it's made—

- Powdered Catechu.....5 pounds (Also known as Cutch or Terra Japonica)
- Alcohol2½ Pints (Denatured or Wood)
- Water, sufficient to make2½ Gallons

Take one half the quantity of water called for and heat it so that it is warm, but not hot, then add the catechu, small quantities at a time and stir constantly while adding.

After the catechu has dissolved, add the alcohol to the mixture already prepared, and stir well for about three minutes until all the ingredients are thoroughly incorporated.

Finally add the remaining quantity of water which has also been previously heated and stir well while adding and the preparation is ready to be placed in suitable glass or metal containers.

To use, the radiator cap is simply removed and about a teacupful of the mixture is poured into the radiator and while not necessary somewhat better results are obtained if the preparation is heated slightly just before being poured into the radiator. The preparation hardens on exposure to the air and automatically seals the radiator leak and such of the compound that remains in the cooling system is harmless.

If desired the preparation can be improved upon by adding to the part of the water that is mixed last approximately four tablespoonsful of ground flaxseed just before it is added to the previous mixture.

Note—The quantities specified in this formula are given mainly to show the relative proportions of the necessary ingredients in the event it is desired to mix a larger or a smaller quantity.

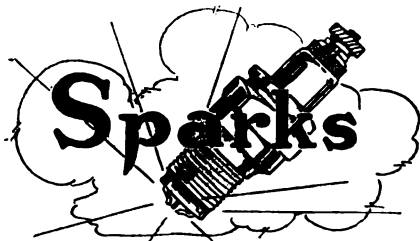

The clove business is beginning to show signs of panic.

There is only one other fool like an old fool and that is the young fool that marries an old fool.

There will be German waiters at the peace table.

If we ever have moments of doubt it is when men like Theodore Roosevelt have to die and Bill Hohenzollern still lives.

When we recognized Poland's independence we didn't mean that she should be too darned independent.

Just as der kaiser said—German ships are landing troops in New York.

The breath of suspicion is one that smells of cloves.

When a man gets old enough to have boys of his own to lick he likes to brag that when he was a boy he never got a licking that he didn't deserve.

By listening to women talk you discover that there are different forms of emphasis. And by looking at their clothes you will discover that there are different emphasis of forms.

A married man has to argue so much at home that you would think he would keep quiet when he is downtown. But he isn't.

A felt slipper is supposed to be soft. But many a boy can tell you that a slipper can be hard and still be felt.

It must be a great relief to Gott these days to know that he isn't expected to strafe anything and everything that doesn't wear an iron cross.

Portugal is another example of trying to be a Republic without the little red school-house.

The boys over there who had an ambition to cross the Atlantic still have the same ambition.

Tom and Jerry have secured positions in Mexico for the next winter.

The distillers would do well to invest what they have left in government bonds instead of lawsuits.

Now that women are no longer knitting sweaters we fear a return of the doily peril.

Of course a cat may look at a king but it will have to hurry.

Several bars will be added to the music of the world when our mahogany of the tap-rooms is sawed into piano legs.

The difference between a matrimonial match and an ordinary match is that an ordinary match can have but one flare-up.

OUR OWN BEER BUTTONS

NO BEER, NO WORK;
NO WORK,
NO PAY;
NO PAY, NO FOOD;
NO FOOD,
NO EXISTENCE—
LET'S ALL GET MAD
AND
STARVE TO DEATH!

—New York Evening Sun.

THE RETURN OF THE COLORS

(Two colored regiments that distinguished themselves on the field of honor recently returned to this country.)

See dem bay'nets flash and flicker!
Boy! dat jazz hits me like lickier!
Hear 'em whale dem kettle-drums—
Whee! dat cullud reg'ment comes!
Clash! Thud! Bang! Zing!
Babe, ma heart does surely sing!

Honey Boy! dere's Henery Johnson—
Watch yo' step, girls, he's a bear!
Dat's de kid killed fo'teen Bushes:
Zingo, zingo, dat jazz air!
Honey, honey, dis jazz stuff'll
Shorely make ma feet go' shuffle—
Clash! Thud! Bang! Zing!
Watch me pull this buck-and-wing!
Wickedest babes I evah saw:
Slashed dem Bushes an' ate 'em raw!
Dey ate dem Bushes fer a picnic lunch
An' foun' no white meat in de bunch.

Halleluia! See dem knives!
Carve me a bit o' de Kaiser's gizzard—
Say, I'm sorry for dem Bushes' wives—
Dere's Jim Europe, he's de wizard:
See Jim Europe lead dat band!
Oh, de wail of dem trombones!
Kid, I'd eat right outa his hand—
Click, clack, rattle de bones!
Hear de squeal o' dat crazy flute,
Watch dat Gov'nah man salute!
Ain't dat roaring jazz a daisy?
Ev'ry cullud heart is crazy!

Watch dat big buddy ovah dere,
Dat's a boy wid a Crow de Gare—
Zing! Zing! dem flags do flutter,
Babe, dis tastes as sweet as butter—
Hear dem drummers boom an' thunder:
Boys dat plowed de Bushes under!
Clash! Thud! Bang! Zing!
Watch 'em swing, girls, watch 'em swing!

See dat cunnel wid a proud, proud walk!
Dem boys makes him look white as chalk!
Dem big officers is mostly white,
But black's de color fo' love an' fight!
Babe, I'd like to hug dat dandy—
Must hug some one—dat you Mandy?
Yo' black face come kinda handy!
See dem bay'nets flash an' flicker,
Se dem ribbons on de flag!
Never was no dough-boys slicker—
Put old Kaiser in de bag!

Thud! Bang! Boom! Clash!
See dem chicken-carvers flash!
Hear dat jazz, as strong as whisky—
Lord, my heart is debil-frisky;
Watch dem he-boys marchin' back—
Praise de Lord dat made 'em black!
—Philadelphia Evening Ledger.

A practical salesman is one who doesn't lose his head and slam his competitor when the customer thanks him and says he will come in again.

You can tell the war is over. The members of the Hot Stove club have quit licking the Germans and have begun to win the pennant.

Business men will remember that it was an offensive campaign that won the war. You can't always see through a man because he's cracked.

The character of a man is shown by his features. The character of a store or place of business by its appearance.

When time hangs heavily on your hands you can always pawn your watch.

A man is known by his deeds, especially if he happens to own any real estate.



WHO WOULDN'T BE A DOWNTRODDEN BLACKSMITH LIKE CHESTER CONKLIN WHEN A PEACHERINO LIKE PHYLLIS HAVER COMES TO HAV'ER PONY'S TOOTSIES MANICURED? BUT JUST WAIT A MINUTE TILL LOUISE FAZENDA GETS HER BREATH AND THEN THE ARMISTICE WILL BE DECLARED OFF-SCENE FROM "THE FOOLISH AGE" A PARAMOUNT-MACK SENNETT COMEDY.

All things may come to those who wait but success doesn't always tip the waiter.

The trouble with the man who thinks he is wise is that he wants to devote most of his time to telling about it.

When a man eats like a hog nature tries to warn him by making his stomach so big it crowds him away from the table.

The old fashioned boy who used to want to go west and kill Indians now has a son who wants to go west and get into the movies.

To say that a man has outlived his usefulness is only another way of saying he never had any.

If the L or N cannot prevent war it can at least guarantee that those insisting on war will get all they want.

We all like to have square customers 'round.

Not "If I could" but "Hanged if I won't" is the proper spirit.

An egotist is a fellow who stands in his own light and thinks all the world is dark.

Two heads may be better than one, but one is quite enough on the morning after.

Any society man will tell you that it don't take a botanist to pick out the wall-flowers.

There is a future in the diplomatic service for the fellow who sent a girl 18 roses on her 28'th birthday.

You never can tell. One man may have more dignity in his shirtsleeves than another in a silk hat and frock coat.

That things are not always what they seem is demonstrated by the failure of some people to reach the top because they hesitate to take the plunge.

At any rate the price of milk never seems to reach the high water mark.

"Them was the happy days" Will it be proper for the old fashioned grandpa of days gone by to hold his grandson on his knee and tell him of the merits of his favorite brand of "Old Kaintuck" that used to be?

Memorial Day 1919



"FOUR score and seven years ago, our fathers brought forth on this continent a new nation, conceived in liberty and dedicated to the principle that all men are created equal. Now we are engaged in a great civil war, testing whether that nation, or any nation so conceived and so dedicated, can long endure. We are met on a great battlefield of that war. We are met to dedicate a portion of it as the final resting-place of those who here gave their lives that that nation might live. It is altogether fitting and proper that we should do this. But in a large sense we cannot dedicate,—we cannot consecrate,—we cannot hallow this ground. The brave men, living and dead, who struggled, here, have consecrated it far above our power to add or detract. The world will little note, nor long remember, what we say here, but it can never forget what they did here. It is for us, the living, rather to be dedicated here to the unfinished work that we have thus far so nobly carried on. It is rather for us to be here dedicated to the great task remaining before us, that from these honored dead we take increased devotion to that cause for which they gave the last full measure of their devotion; that we here highly resolve that these dead shall not have died in vain; that this nation under God, shall have a new spirit of freedom, and that Government of the people, by the people and for the people, shall not perish from the earth."

—Abraham Lincoln.

Benton's Recipes

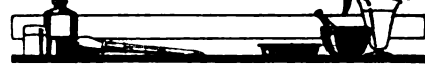

To Produce a Bronze Color.—A bronze-like color can be produced by exposing iron and steel parts to the vapors of heated aqua regia, dipping them in melted vaseline, and then heating them until the vaseline begins to decompose, when it is wiped off with a soft cloth. Another method of producing this bonze-brown color is to slightly heat the work, cover the surface with a paste of antimony chloride (known as "bronzing salt"), and let the object stand; by adding a little nitric acid to the paste it will make it more active.

Oil Stains on Concrete Floors may be removed by covering with a mixture of 1 pound of oxalic acid, 3 gallons of water and enough flour to make a paste that can be applied with a brush. The paste is removed with clean water.

Emergency Repairs of Boiler Furnace.—When it is necessary to repair the boiler furnace and fire brick cannot be obtained, take common earth, mix with water in which has been dissolved a small amount of common salt. Use this mixture the same as fire clay. It will be found to last almost as long.

To Loosen Pasted Paper—Sometimes it is desirable to loosen clippings that have been pasted in scrap-books, etc. To remove them by soaking in water is slow and is likely to injure the clipping or book unless extreme caution is employed. This trouble may be largely avoided by covering the face of the clipping with flour paste instead of water; the fresh paste soaks into the paper quickly and loosens the dried paste underneath. When the clipping is loosened the fresh and dried paste is readily washed off, of course. The same trick will be found to work well with old wall paper. The superior action of paste to water is due to its wetting the paper all over and having no tendency to run off.

Marking Polished Steel.—A very handy way of marking polished steel for sizes, instructions, etc., is to keep a small oil can filled with turpentine with which to saturate a small piece of waste as needed; rub over the surface to be marked and then do the marking with an indelible copying pencil, which will show up very plain. Of course the can of turpentine also comes in handy to use for drilling hard steel, springs, etc.

Leather Renovator—A formula for preparing a leather renovating mixture consists of darkening neatsfoot oil with ivory black, applying this mixture to the leather with a soft cloth and then polishing dry. This serves to preserve the top and to give pliability to the leather. In respect to genuine mohair tops with a rubber interlining, which all double texture mohair fabrics, have, the safe and sure treatment consists of a brisk brushing with a stiff broom, or a careful cleaning with castile soap and soft water, the condition of the top suggesting which of the two treatments is most desirable for the case in hand.

In any event, the application of kerosene, gasoline, or any petroleum by-product, or any oil of a similar nature, may be considered very detrimental to the mohair top and destructive to the rubber interlining.



BERT STOREY'S SHOP IN
MICHIGAN
LAST YEAR BERT SOLD 168
AUTOMOBILE TIRES, 11
BARRELS OF OIL, 500 POUNDS OF
GREASE, 118 SPARK PLUGS,



ETC. BERT WASTES NO REGRETS ON THE
PASSAGE OF HIS SHOENING BUSINESS AND ITS
ATTENDANT BACKACHE.



TWO HANDY TOOLS

These are two handy home made tools that have proven their worth many times. Both of them are made from bar steel. As the drawing seems to clearly convey their construction, hardly any description need be given. The shaft

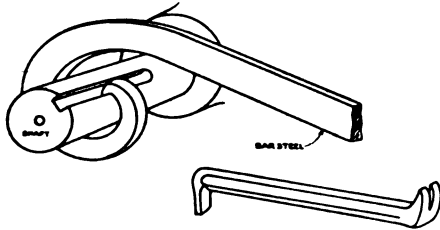

spanner is designed to turn motor or engine shafts by aid of their key ways. It will fit several size shafts. The combined claw and offset screw driver is handy in any tool kit.

HANDY COMBINATION HAMMER

This is a practical invention that the writer evolved in his home workshop—a combination hammer—the idea being to make one tool answer the purpose of many. Such a tool, as shown in the sketches should be appreciated by all journeymen mechanics.

The hammer body is made similar to the standard machinist's hand hammer, except that the upper head is bored out as shown in Fig. 1, the hole being 5-8 inch in diameter and 1-2 inch deep. Then

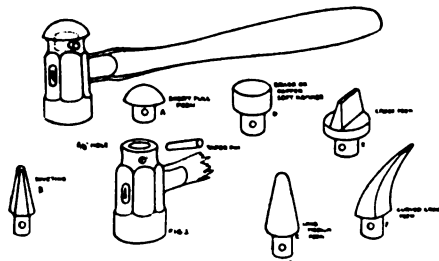

the various attachments or heads are made to fit the hammer. A regular machinist ball peen hammer is obtained by use of the attachment A; a flat riveting hammer by the use of the attachment B. C is a long medium peen. D is a brass or copper plug for supplying the need of a soft faced hammer. E. and F are cross peen. All of these with the exception of D are hardened. A taper pin secures them in the hammer.

Some business wanders in; some must be coaxed in, but you get most business by going after it.

CIRCLE OR GASKET CUTTER

The device is the writer's own idea and was made to answer the need of an adjustable circle cutter for cutting packing for gaskets, glass for clock gage and instrument dials, circles in thin sheet stock, etc.

It seems to me that such a tool will be well worth the time spent making it for any auto or tractor repair shop. I found it indispensable after I constructed and used it. The assembled view given in Fig. 1 shows how the device is operated and the manner in which it is secured to the wall, while in the smaller sketches A to E are given the details of each part. I have not given any dimensions, for of course, the device must be made to suit the user. The size I made

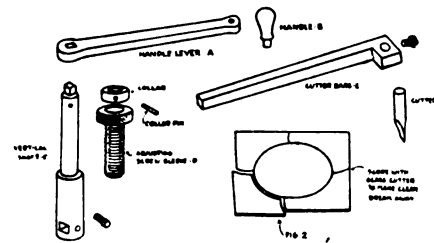

has a range of circle cutting from 1 1/2 to 14 inches. In cutting any material it is essential that a true, flat board be used under the material, as indicated in Fig. 1 at F. The packing is fastened with thumb tacks to the board and the board is fastened by screws to the bench. When cutting glass discs, lay a sheet of desk blotter under the glass and insert a glass cutter in the end of the cutter bar. Never make more than one revolution in cutting glass—one score makes a clean break. To remove a glass

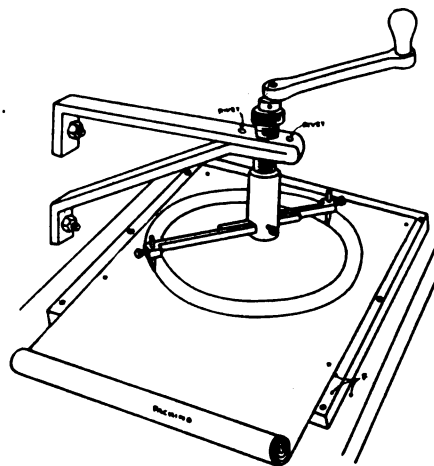

disc cut out of a pane of glass, it is necessary to score the outside glass, as shown in Fig. 2; the pieces then break away clean.

The Kink and

UNIQUE OPEN END WRENCH

One afternoon an old fellow came into the shop and asked us to make him a special kind of an open end wrench. He proceeded to make a sketch and gave the dimensions. The tool was of his own invention, the idea being to make a single wrench handle serve the purpose of various angle wrenches by making the handle fit several size and angles of jaws. The sketches here show his idea, which though odd, nevertheless has a unique value and interest to others needing such a tool. It was made of a good grade of machine steel and hand forged.

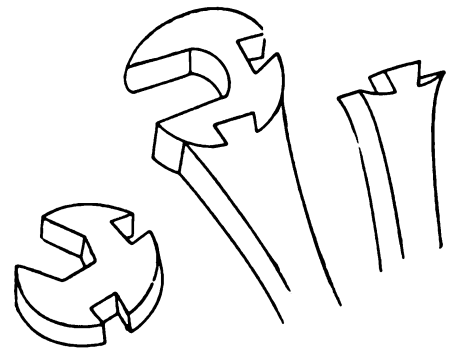

The circumference was filed to a true circle and the dovetail slots cut by clipping and filing. Perhaps others might improve on this idea and pass the idea along.

PORTABLE HOIST

A convenient and satisfactory arrangement for hoisting heavy weights, such as cylinder castings, pulling engines, etc., around the

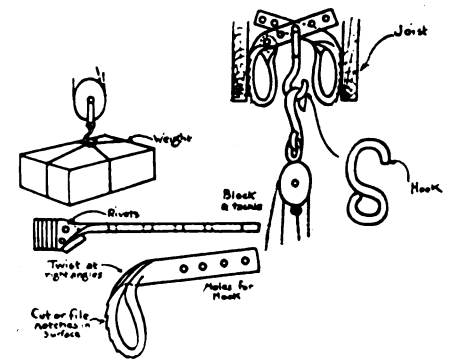

shop, is made and applied as shown in the illustration.

The holes in the grips make the grips adjustable for different spaces between the joists.

Note Corner

LIGHT REFLECTOR

When working on the transmission, crank case or differential through openings for finding broken gear teeth, etc., that may be inside, a light reflecting mirror will prove a great help. The openings

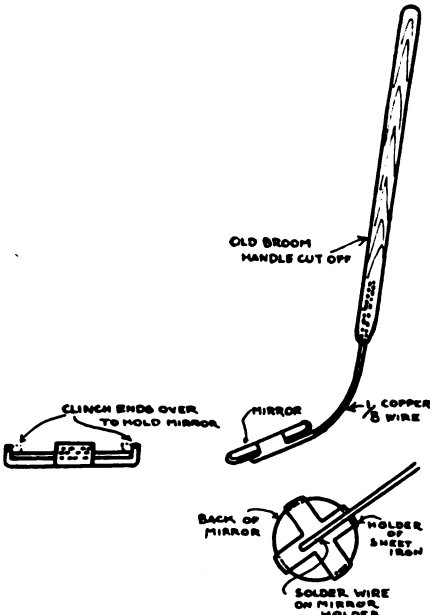

usually provided are usually too small to get an electric lamp inside or at any rate it is generally impossible to get the light exactly where wanted in which case such a mirror is valuable.

CUTTING WIRE OR PINS

Where wire is to be cut into lengths for any purpose an easy

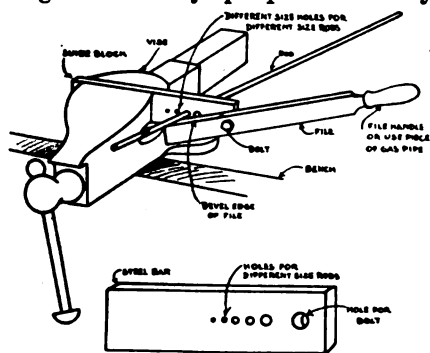

operating cutter simplifies matters considerably, and such a cutter is shown in the illustration.

A saturated solution of turpentine in alcohol makes an effective preservative for rubber. The point of saturation is reached when a drop of undissolved turpentine remains suspended in the alcohol and a little more of the spirit should be added to dissolve the turpentine. Rubber articles should be painted with this solution occasionally.

TEST CENTERS

A set of test centers for testing the alignment of shafts, etc., that are adjustable for distance is

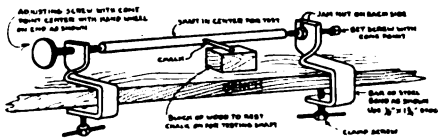

shown in the accompanying drawing. By rotating the shaft or other object and holding a piece of chalk on a block the part of the shaft out of true can be quickly located.

COLLAPSED RADIATOR HOSE

It often happens that the radiator hose collapses due to excessive suction and other conditions. To overcome this and to prevent the hose pinching together and stop-

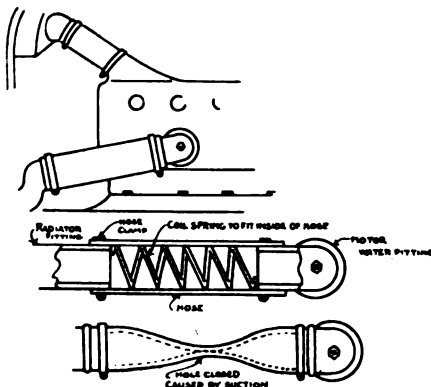

ping the circulation a coil spring is made and inserted inside the hose as shown. This simple idea has saved many an engine from burning up.

SAVING FUEL

An old piece of stovepipe and an elbow arranged as shown will make a heater that will keep the shop

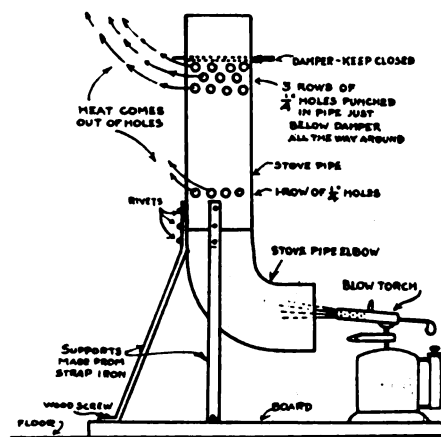

comfortably warmed up in the cool days of spring and fall. Naturally such a device should not be placed close to any inflammable material.

FORMING PUMP LEATHERS

Various makes of pumps use leather cups for valves and packing and the illustrations show a simple method of forming such cups in case of emergency. The leather should be first soaked in

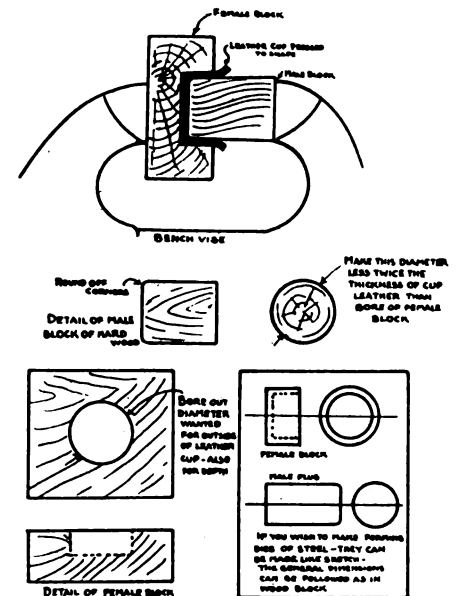

water for an hour or so until soaked through before placing in the forming blocks. The leather should be allowed to remain in the blocks under pressure until dried.

GRINDING VALVES WITHOUT REMOVING

The illustration shows a simple method of grinding valves of the valve cage type without removing

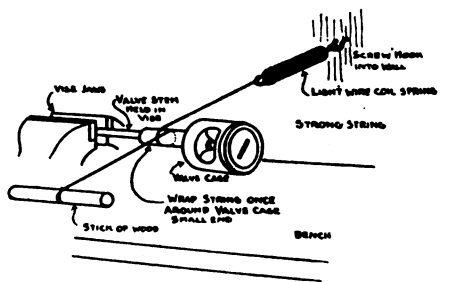

them from the cages. Simply pulling on the handle imparts the necessary rotary motion for grinding the valves.

Various kinds of tools made of flat pieces of steel can be cut from old saw blades, ordinary handsaws being used for the thinner stock, and heavier circular saws for heavier material. The steel must be annealed to make it easily workable, and the tools may be hardened if desired. Some of the tools that can be made in this way are squares, calipers, gauges, and various types of measuring and marking tools, shaped from flat steel.

Two Jobs in One Fire

DAVID BAXTER

DOUBLING up on welding is one of the ways the awake oxyacetylene welder cuts the cost of work, thereby enabling him to enlarge his profits, meet competition, and save time. This doubling up may be accomplished by employing two torches on one job, or two torches on two jobs in one fire. Or by one man so arranging the work that he can in reality weld two jobs at once, as was done with the castings illustrated in the photos accompanying this article.

The Jobs.—These two jobs, as shown in picture No. 1, were a steam engine cylinder weighing 100 pounds and an automobile engine valve head. Both were badly broken. The steam cylinder had a section broken out of the outside

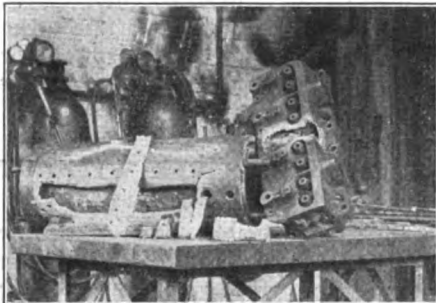

1—THE TWO JOBS

wall; this section being broken into five smaller parts. The cylinder also had a crack parallel to the broken place. It will be seen that there are a number of holes around the edge of the break. These holes were drilled by some repair man who had tried to patch the break with sheet iron. The problem which confronted the welder in the case of the broken cylinder was rather a complex one: he must first weld together the small pieces, then weld the whole in place in the cylinder; he must weld all of the drilled holes; and then weld the crack. It was decided best to do this a part at a time in conjunction with the work on the valve casting. In this way the operator could keep up the expansion much easier.

The work on the valve head was not so extensive, but was what is called a bad job on account of the

location of the break. Which divided the work into two parts. The one part, which was the original break, was a crack in the inner wall. The other part was a section of the outside of the casting, which had to be removed in order to be able to weld the inner crack; this section and the resultant opening are shown quite clearly in picture No. 1. A section of the top of the valve head running across the top and down one side of the casting had to be entirely taken out. This, of course, made an extra weld, but there was no better way of reaching the inner break—a crack about five inches long across the top and two inches down the side. This section was removed by drilling numerous small holes around it which were cut into one with a sharp chisel.

Preparing for Welding.—Before attempting to weld jobs like these a certain amount of preparation is essential in order to facilitate the work and insure a strong, homogeneous weld. Both castings were cleaned of all rust and dirt for a space of two inches around the broken sections and along the cracks. The cleaning was done with a sharp chisel and file. This cleaning prevents any foreign substance that might be harmful to the weld from getting into it. The edges of the breaks were then cut back with a chisel until they formed a V shaped notch, when the broken sections were placed in concurrence with them; the edges of the loose sections were beveled by grinding on an emery wheel. The crack in each casting was also cut away with a diamond pointed chisel in the form of a V groove. The grooves were about as wide at the top as twice the thickness of the metal and to a depth equal to the thickness. Or in other words the groove reached the bottom of the crack.

After all broken edges were chamfered, the small pieces of the loose sections were bedded in moist earth to make sure they fitted together exactly, and to hold them together while they were spot welded. A handle was welded to the loose piece of the valve head

to aid in placing it in the break after the inner crack had been welded; some such device was necessary on account of the shape of the piece forbidding the use of tongs. The piece had to fit quite accurately, not merely dropped into place haphazard. Picture No. 2 shows a piece of filler rod welded to the loose section of the valve head. This picture was posed to show the meaning of the handle just described and how it was inserted. The asbestos covering and the gas burner are merely to symbolize the use of these things. Had the valve head been welded alone this arrangement of covering and preheating would have been employed.

Before placing the jobs in the preheater the broken section of the steam cylinder was fitted in place and tacked there at two ends with spot welds; this insured it remaining in place during the preheating. Picture No. 3 shows the cylinder ready for preheating, broken section in place. This picture also shows the V grooving quite clearly.

The Preheater.—Next, a fire-brick oven-like structure was built on the floor of the shop in a specially prepared space for this kind of work. A tier of brick was placed in a square the desired dimensions; a number of iron rods were placed across the bricks to form a grating upon which the castings were to rest while heating. Then a small

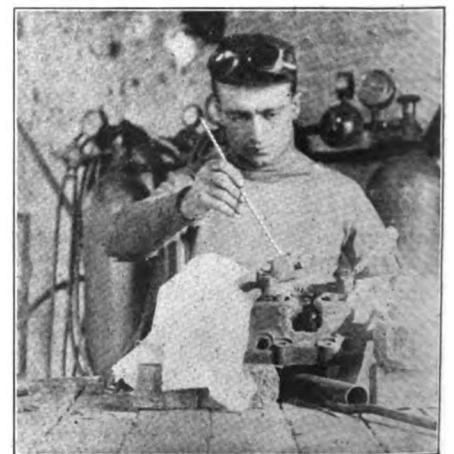

2—METHOD OF INSERTING LOOSE PIECE IN VALVE HEAD

wall about two feet high was laid on top of the first layer. A gas burner was set on each side of the oven, arranged to spread the heat evenly. Both jobs were placed side by side on the grating with the breaks upward. The gas was lighted and regulated so the flame surrounded the whole of both castings. After making sure that both jobs were being heated the same, an asbestos covering was placed over the entire oven and the castings were allowed to preheat. Both jobs were placed in the oven with the broken side upward, which precluded any necessity of turning them while hot. Picture No 4 shows the preheating oven after being covered with scrap asbestos paper.

This sort of preheating system is quite popular with many welders because it is cheap and easy to construct and is readily adaptable to any size or shape job. It may be

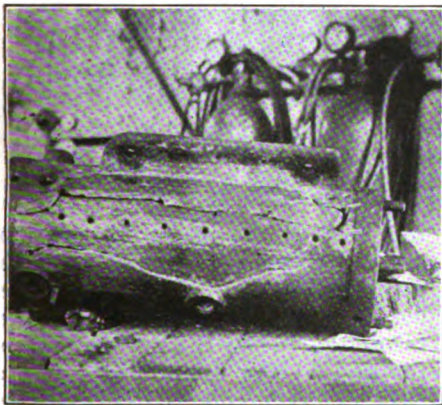

3—CYLINDER READY TO PREHEAT

made larger or smaller to fit the job. When not in use it may be piled up in a corner or out of doors. It is not essential to use whole brick, therefore the welder will do well not to throw away any pieces of fire brick.

Other Fuel.—Where there is no gas for preheating fuel on jobs like that described, the welder can use charcoal if he arranges for draught by leaving out several bricks of the oven wall and by having openings in the asbestos. The charcoal should be burning good before putting the jobs in the oven. Perhaps some sort of grating will be needed under the charcoal, too.

Making Preparations.—While waiting for jobs to preheat is a good time to do several minor things to facilitate the actual welding. Everything should be in readiness so the welder will not have to interrupt his work.

While our double job was heat-

them near the work. The flux pot was also replenished with fresh flux, borax. The regulators and tanks were examined to see that they were set right and had a sufficiency of gas.

It sometimes occurs that a weld is lost by running out of gas right in the middle of a particular part of it. A bucket of cold water was handily arranged so the operator could cool the torch or wet his cotton gloves. None of the little details connected with welding were left unattended to, for it is often the little things that make for success in the big weld. While these details were being arranged, the jobs were heating in preparation for the welding flame. As soon as it was certain that the castings were hot enough, that part of the asbestos covering directly over the steam cylinder was partly removed. Through this aperture the operator applied a standard neutral flame to the break in the cylinder job.

The Welding.—He first welded in the loose section, starting near the end, the torch operator selected the proper tip (a number five for a certain make torch) and fitted it to a long torch; a long torch on this kind of work saves the operator a great deal of discomfort due to the heat of the fire and castings. The operator also selected several filler rods of soft cast iron, three sixteenths inch diameter, and placed one end and working along one side about a third of the way along the groove. Then going back to the end again and welding along the other side about two thirds of the groove. He then switched to the first side and welded it to the end before changing back to the second side and finishing the main weld. He next welded up the holes between the crack and the broken section. This changing from one side to the other of the break was with the idea of equalizing the expansion and contraction; each section of the weld was left free to expand and contract by not welding the opposite side until the reactions had a chance to work. By welding the holes right after finishing the break the welder was

able to take advantage of the expansion of the hot weld. This made it reasonably certain the contraction of the break and that of the holes would act together.



4—PREHEATING OVEN.

The operator now covered the cylinder job and allowed it to heat again while he attacked the inner crack in the valve head; this gave the cylinder an opportunity to get hot again, if by chance it was cooling enough to be near the danger zone.

The valve head was welded by starting at the top end and welding across the top and down the side. Welds in such close quarters require a rapid manipulation of the torch and filler, or else the tip will get hot and cause the torch to backfire. Or perhaps melt the tip. Just as soon as the crack in the inner wall of the head was completely welded the operator covered up the casting and switched back to the cylinder job, which had in the meanwhile become hot enough once more. Thus permitting the head job to bring up its expansion. The

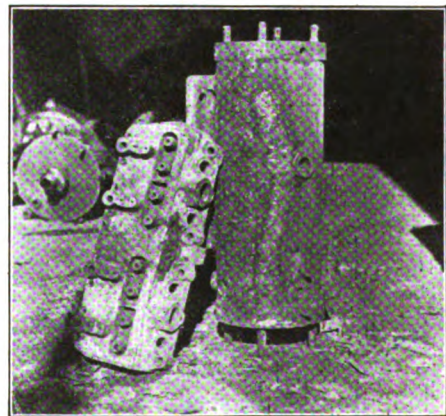

5—THE COMPLETED JOBS

weld was started at one end of the crooked crack and welded the entire length of it as quickly as possible. Then covering the cylinder job he changed again to the head job and finished it. The loose sec-

tion of the valve head was inserted with the handle described, and held until two or three points of contact were spot welded, then the filler rod handle was melted off and the main weld finished as follows: The weld was started at one end, a couple of inches was welded, the flame was shifted to the other side at the same end and a couple of inches welded. This shifting back and forth was similar to that on the cylinder weld and for the same reason. By welding down both sides of a patch we always work toward an open end, which will allow some play for the expansion and contraction.

Handling Torch and Filler.—The actual welding was accomplished on both jobs in the following manner: First, an inch of the groove was heated to a melted stage; at the same time about a half inch of the filler rod was melted into the melting groove. Care was taken to make sure the sides and bottom of the groove melted before the melted filler was worked into it. This groove being comparatively small the entire depth of each inch was melted full before repeating the process by advancing another inch. At intervals of about half a minute the flux was applied by dipping the melting end of the filler rod into it and quickly returning it to the weld. Meanwhile the flame was kept in motion, moving around in tiny circles over the melting weld, anon playing across the crack ahead to prepare it for the coming weld. The grooves were welded thus an inch at a time until their entire length was filled. Each inch was completely melted and mixed into the preceding one before leaving it. Keeping a wary eye on the sides of the grooves, too.

Hot Finishing.—As soon as a couple of inches had been welded full the operator swung the torch back across the welded spot to smooth out any roughness. The pressure of the flame was used to blow across the surface of the melting spot, thus smoothing it. A nice appearing finish may be given to a weld if the flame is manipulated correctly; in effect like a paint brush, the fluid iron is brushed about as desired. If the hot finish is properly executed it is not necessary to touch up the weld after it is cold. However, any welder will find it a paying proposition to grind or file off the roughness after the job is cold. It makes his customers better satisfied; satisfied customers boost, the

other kind knock. Some welders always resort to a coat of paint, but somehow a coat of paint is suspicious; it makes one feel like some defect is hidden under it.

Slow Cooling.—Picture No. 4 shows the preheating furnace covered with asbestos scrap paper. This is to cause the casting to cool slowly by preventing the heat from escaping. Or in other words, to prevent one portion from cooling first, which would result in a cracked weld, or some other weak part of the casting, when the hotter portion cooled and contracted. The cylinder and valve jobs were allowed to remain under cover in the oven for about three hours or until they were cool enough not to burn the bare hand. They were then taken out and thoroughly examined for possible defects. Had a crack developed the entire work would have been to do over again. In picture No. 5 we have the welded jobs ready to be put back in service.

STRAIGHTENING FORD RADIUS RODS

A time saver for straightening Ford front axles is made from an old buggy axle cut off as shown in Fig. 1. A good heat is taken and it is bent to the shape shown in Fig. 2 so that it will fit nicely over the Ford axle as shown in Fig. 3.

A buggy axle is just the right length and one man can take the kinks out of a radius rod with-

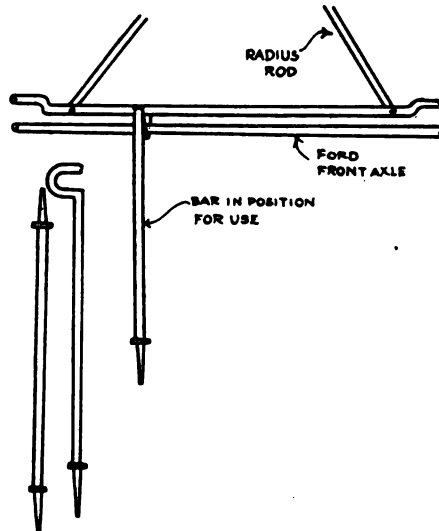

out removing anything from the car. Hook your bar to the front axle as shown and raise gently until the bar is straight up and down with the radiator and the job is done.

The reason radius rods should be straight is because it is almost im-

possible to keep the car on the road with bent radius rods, as the car will travel from one side of the road to the other, and often the operator is inclined to think that his steering apparatus is defective.

Carl Ziehe, Iowa.

PISTON RINGS

John Y. Dunlop

In these days when so many amateur mechanics are, for the sake of economy doing their own repairs, one cannot know enough and cannot be too carefully guided in the details of the engine.

In the construction of the piston,

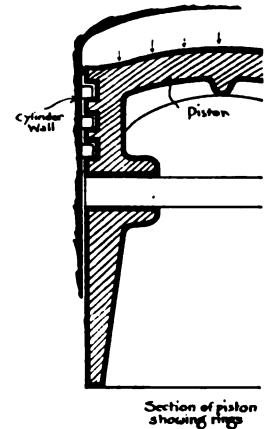

the idea of the piston rings is to prevent the gases blowing past the piston while they are acting on the bottom and cylinder wall, with the result that when the gases blow on the end of the cylinder they also pass along the side of the cylinder wall until they come into contact with the back of the rings with the result that the continuous friction of the face of the ring with the grooves in the piston maintain a gas-tight joint.

A small particle of soot or other foreign matter, a dent or other imperfection in replacing the rings may be sufficient to cause more or less trouble.

The existence of the bad joint may be found by examining the rings after the car has done a half day's work on the road. If the rings are then taken off and they have been bearing well and the joint is good the face of the ring which is bearing on the groove on the cylinder will be found more brightly polished than the top side. Therefore, when replacing the rings be sure that the brighter side is placed down which brings them in the same position as before. Time and trouble can usually be saved by replacing each ring in its own groove.

AUTO BODY MADE OF HUGE REDWOOD TREE

Albert Marple

Talking of freak automobile bodies—here is probably the most novel yet to make its appearance. This automobile has been termed "the big tree car" on account of its body being made of a portion of the trunk of one of the giant red-

thirty-three feet in circumference.

Upon being stripped of its bark the tree was, after many difficulties, hollowed out. The section, which weighed more than forty tons, was moved into position for working by the aid of the truck. The preparing of this log took weeks of time and after it was finished it was jacked up and the truck was run beneath it. When

that it presents a very beautiful appearance.

Mr. and Mrs. Kellogg are touring the country in this remarkable limousine", traveling from city to city in which the bird-voiced artist has entertainment engagements.

DESIGNING AND FORGING TONGS

J. C. Lamon

Efficiency in the blacksmith shop as well as in any other line, of work, requires not only intelligence, but essential tools and equipment to handle the work at hand.

I wish to speak of a part of that equipment, very essential, but often deficient in a large number of shops; that is tongs. I wish to give my method of making them, and trust the illustration will make it clear. By referring to the illustrations and the table of sizes, will give one a correct idea as to the proper design. The table of sizes given is taken from tongs of my own make which 25 years of practical blacksmithing has proved to be approximately correct. However, the sizes given, might be varied to suit the smith and the work they would be required to handle.

I am aware of the fact that to many who may read this article, the design and descriptions are nothing new; but to those who may not be familiar with the designing and forging of tongs, I trust this little

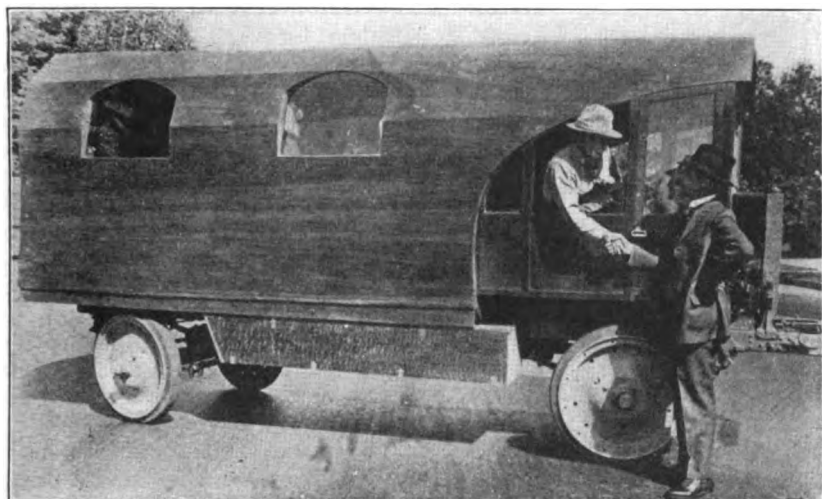

THE BODY OF THIS CAR, MADE OF A SOLID REDWOOD LOG WEIGHED 40 TONS AND REQUIRED WEEKS OF TIME TO BE HOLLOWED OUT—HOT AND COLD RUNNING WATER AND OTHER COMFORTS OF HOME ARE SOME OF THE FEATURES OF THE CAR

wood trees of California. The "romance" of this unique body is interesting.

The owner of this unusual machine is Charles Kellogg of Santa Clara, California, who, on account of his wonderful birdlike impersonations, is known as the man with the throat of a bird. Mr. Kellogg is an ardent lover of nature and it is said that he spends so much of his time in the open and among the birds that he has become thoroughly acquainted with their customs and peculiarities, even to their method of singing.

Several months ago Mr. Kellogg conceived the idea of taking a section of a huge redwood tree around with him on his travels, his profession being that of an entertainer. An especially prepared four wheel driver chassis and motor were built for the proposed wooden house and this was shipped to the Kellogg ranch near the side of Mt. Hamilton, twenty miles from San Jose. In this truck Mr. Kellogg and his wife journeyed to Scotia in the Eel river country, where they secured from a lumber company a section of a large redwood tree, this being at the point selected, twenty-two feet long and

dried the finished article weighed 5,000 pounds. Later the car was finished with windows and doors, and, inside, it was equipped with beds, kitchenette, closets, electric



THE COMPLETED BODY WHICH WEIGHS 5,000 POUNDS IS CARRIED ON A FOUR WHEEL DRIVE TRUCK WHICH STEERS, DRIVES AND BRAKES ON ALL FOUR WHEELS

lights, and many other features that would add to the comfort of the occupants. Both inside and out this log body has been polished and varnished in the natural wood, so

article will be of some assistance.

Referring to the illustrations: the flat-lipped tongs shown at figure "A":—This type of tongs is used to handle wide stock, the lips pre-

venting the material from slipping edgewise. Instead of having a large number of this type of tongs to cover the wide range of flat work, an effective type can be made

To forge the goose-neck tongs, select the stock of the proper size, drive the "fuller" into stock at "a". Fig. "D". Refer to design Fig. "D-a"; then draw out reins to proper

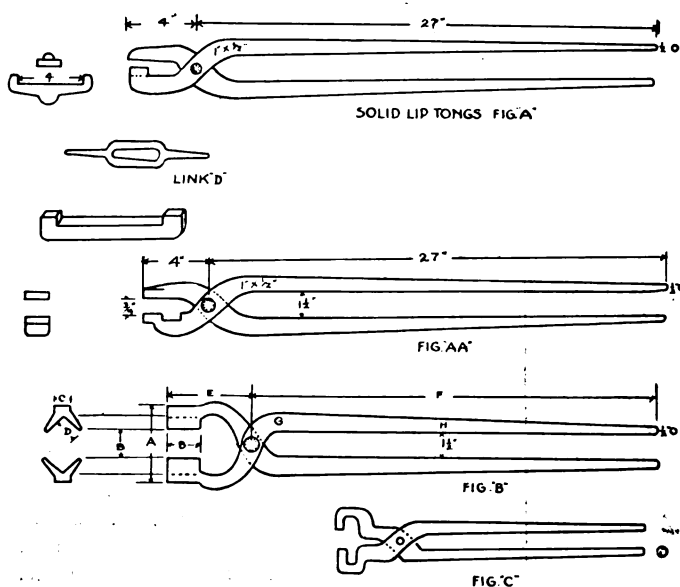

size, work section "b b"; next drive hot cutter into section "c c"; then spread on a piece of square stock.

The sketch of each operation is shown at Fig. "D", necessary to develop the goose-neck tongs. As this type of tongs is harder to make than the other types referred to in this article, I do not think it necessary to elaborate

further with each operation necessary to make them.

Often the tongs become very highly heated owing to handling work close up in the forge fire;

to accomplish the same results by having adjustable jaws; this jaw is made to fit the stock and the same effect is accomplished almost as well as with the type "A". Refer to design Fig., "AA"; the dimensions shown are for a pair of tongs handling stock 1"x4". For the heavy or lighter work, each pair could be proportioned according to scale of sizes given for the Goose-neck tongs "B", except as to letters A-B-C-D and E. The goose-neck tongs figure "B", will handle square, round or irregular shaped stock effectively, or will accommodate a piece of stock with a head or burr. For holding the tongs upon the work, the link "D" will be found effective; the projections facilitate the turning of the work under the power hammer.

Design Fig., "C", will handle rings, bands or irregular shaped stock, as this type of tongs' range of capacity is limited; it is essential to have sizes sufficient to take care of that class of work. To be effective, they should fit the work well.

To make any of the type of tongs shown, select stock of proper dimensions. Square stock is preferable, of soft machinery steel, as it is best adapted.

In forging the tongs, avoid making sharp corners at the joints; as a sharp corner is nearly certain to develop a crack and make the use of the tongs dangerous; especially if forging under a power hammer.

**A NEW, WELL PAID TRADE
The War Has Forced Great Development in Art of Oxy-acetylene Welding.**

One development of the war is the opening of a brand new and well paid skilled occupation—that of oxyacetylene welding. This, and general handling of the wonderful oxy-acetylene torch in other lines, afford opportunities for many men disabled by war. The course is one of the most popular among the 400 trades, occupations and callings offered as free education to discharged disabled soldiers, sailors and marines. Competent handlers of the oxy-acetylene torch are readily hired at good wages by railway shops, electric street railways, in shipyards, in the automobile industry and in repair garages, for gas, sewer and water pipe work, in sheet metal work and in metal furniture making, in foundries and general machine repair shops.

The oxy-acetylene flame is one of the real wonders of the century. When the Germans smashed the machinery of their ships interned in this country, they thought the

| Size of Work | A | B | C | D | E | F | G | H |
|-------------------------------|-------|-------|-------|-------|-------|----|-------------|-----------|
| 5 " square, | 7 1/2 | 2 1/2 | 1 1/2 | 2 | 7 | 42 | 1 1/2 x 7/8 | 7/8 x 3/4 |
| 2 " square, 2 1/2 " round | 4 1/2 | 2 | 1 1/2 | 1 1/2 | 5 | 30 | 1 1/2 x 3/4 | 3/4 x 1/2 |
| 1 1/2 " square, 2 " round | 4 1/2 | 2 | 1 | 1 1/2 | 5 | 28 | 1 1/2 x 1/2 | 1/2 x 1/4 |
| 1 1/2 " square, 1 1/2 " round | 3 3/4 | 1 1/4 | 3/4 | 1 1/4 | 4 1/2 | 24 | 1 1/2 x 1/2 | |
| 7/8 " square, 1 " round | 2 1/2 | 1 1/4 | 3/4 | 3/4 | 4 | 21 | 3/4 x 3/8 | |

Table of sizes.

whenever possible, it would be best to allow the tongs to gradually cool; otherwise, suddenly cooling in the "slack tub" causes crystallization and shortens the life of the tool, often causing their use to become dangerous.

RESERVE POWER DESIRABLE

In purchasing an engine of any type it usually pays to buy one with a little more power than you think you will need. It will cost more, but you may count on it lasting longer. If you need a tractor to pull three plows, it often pays to get one guaranteed to pull four. The reserve power will, of course, cost extra, both when you buy and while you are using it, but the repair bills will be less on a machine which is not loaded to capacity or over, than on one which works with no reserve. And the fuel and oil bill will, in many cases, be less on a 20-horsepower engine pulling a 16-horse load, than on a 16-horsepower engine pulling the overload.

vessels had been put hopelessly out of commission and rendered of no use to the United States. Mainly by use of some skilled oxy-acetylene workers, splintered and shattered

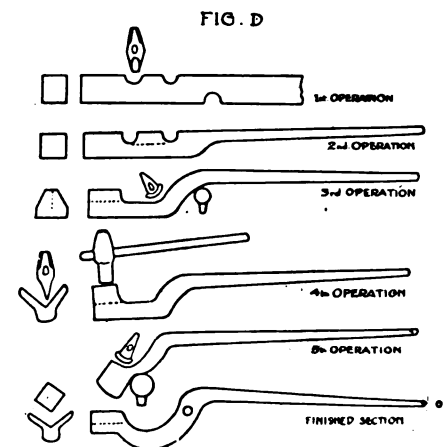

machinery was soon repaired, and the former German vessels have been rendering valiant service carrying men and munitions to France,

and in bringing back our returning soldiers.

Men training as oxy-acetylene workers are given \$65 a month support fund, if single, more if married, and all expenses of training are paid. When the student is pronounced competent a place has been found for him. The Federal Board for Vocational Education, whose address is Washington, and which has charge of reeducating disabled fighters is glad to correspond with war disabled men who are desirous of reeducating themselves so they will rank as skilled workmen in a new and well paid occupation which, for a long time to come will not have enough men in this particular line.

ENGLISH CORRESPONDENCE

John Y. Dunlop

In England at the present time it is becoming more and more apparent that there is no excuse for the continued existence of the Petrol Control Committee.

There are ample supplies of motor spirits in the country and there are excellent prospects of receiving large supplies from overseas during the coming months. Not only that but we have reason to hope for a continuous supply from our own oil fields soon.

Operations are proceeding in Derbyshire and although petroleum has not yet been found the prospects and the progress made have been most satisfactory. Four wells are being drilled and the work is progressing night and day.

The first of these wells was started as long ago as the end of November and the others immediately afterward, and thus three months have elapsed since the inauguration of the scheme. The fact indicates the magnitude of the work when after all that time, and with no oil to show for the work, the term satisfactory is applied to it.

These wells are in the vicinity of the Derbyshire coal fields and care has to be taken to avoid damage to the coal seams, which may of course account for some of the disappointing delay in striking oil. It is a hopeful sign, however, that the state is now taking an active interest in drilling for English petroleum.

The Empire can produce all the fuel necessary, particularly if the authorities will give alcohol a helping hand and if the center of the Empire could produce a "gusher"

what an enormous fillip to mechanical transport both in the commercial and agricultural side would occur.

Motors will add in a greater measure than any man can realize to the commercial and agricultural prosperity of the country. In agri-



culture, one saw before the war great possibilities for motors, but those of us who knew the psychology of the agricultural worker knew how this advance would be delayed by prejudice and conservative unbelief.

The war has cleared all that away and with demobilization we will have thousands of rural born men back on the land with a knowledge of motors. Every week evidence is to be seen of the natural growth of the motor tractor on the farm, and one cannot fail to see that the future of British farming is entirely wrapped around tractor development.

On large farms and small holdings scientific farming is proving itself to be the only way to financial success. My opinion, however, is that agriculture will only pay in a very few years when it is conducted on a very large scale. Prices will eventually be lower for the necessary food products, but wages are going to remain high, and this would be a pretty stiff problem if things were as they used to be, but they will not be. The motor is coming to the rescue and one machine will, in the days to come, do the work of a dozen horses and a half dozen men.

But machines capable of doing this must operate in large fields, as it will no more pay a farmer to have his tractor idle half of the time than it would be to pay his men full wages for quarter time work. Therefore, as on the small farm he cannot get work for his tractors for

a full season he must look for a larger farm. In agriculture the legal obligation to pay high wages on a falling market for produce can only be met by labor saving devices and it is in the operation of machinery that the laborer will find employment.

The motor vehicle in its many forms is going to be in great evidence on the land and the man who knows how to take advantage of it and repair it is the man who will profit most. For them there is a future at home and it is the only future. The adoption of machinery is the only possible reply to competition both in labor and produce.

Questions relating to the development of these large farms and rural districts are engaging much attention and the problem of transport from farm to town or ports is giving our local authorities some concern. A scheme for the establishment of light railways throughout Britain is being urged, while against this proposal the greater economy of motor transport is urged. Advocates of the light railway proposition lay stress on the greater loads that can be carried by rail than by road, but when considering the needs of outlying districts a point is whether possible traffic would justify the expense of a railway or whether all the business offered could not be accommodated by a service of motor lorries.

There is also to be considered the time required for building even a light railway, in view of the fact that a large number of motor wagons and lorries are immediately available and that the roads in most parts are ready for them.

In England the Board of Agriculture is at present conducting a series of experiments in motor haulage of farm produce and the results may have a great deal to do with future agricultural developments.

It seems unnecessary even to mention it, but always be careful to avoid getting the acid from storage batteries on the clothes, as it destroys cloth wherever it comes in contact with it. When the batteries are being charged at a high rate, the bubbles which rise to the top contain gas which is bad for cloth also. Also in carrying a cell, if any acid is on the outside, it will undoubtedly cause any part of the clothing with which it comes in contact to be missing in a day or two.

GOOD REASONS WHY A FARMER SHOULD OWN A TRACTOR

1—A man can do more than twice as much work in the same length of time.

2—He can do the work at less expense.

3—He does it with a character of fuel that diverts feed necessary to maintain horses to raising meat producing animals.

4—The tractor doesn't eat when not working.

5—It prevents wearing out or killing horses on the gang plow, harrowing, and other horse killing jobs, especially in the hot weather.

6—A man with a tractor can raise from 2 to 4 times as much small grain.

7—He can do his work at the right time. Can plow when necessary regardless of heat.

8—He can plow deeper and cheaper.

9—He can wait until conditions are most favorable and then rush his work. There is always a comparatively short time when conditions are most favorable or preparation of soil, seed time and harvest.

10—He can work many hours after horses would be too exhausted to continue.

11—Power is the greatest need of farming—most farms are underpowered.

12—The tractor owner can keep ahead of the season in the matter of seeding, because he can prepare his seed-bed in shorter time.

13—He can do away with surplus horses and save expensive horse feed.

14—The tractor owner can handle more tillable land profitably.

15—He can get a greater crop yield than when planting out of season.

16—The tractor is valuable for belt power purposes.

17—One man and a tractor will replace several men and teams.

18—Can do things impossible to do with man power.

19—The best job of plowing invariably requires most power.

20—Investigations show poorest plowing where smallest amount of available power is found. Ten states where Spring plowing averaged 4.3 inches in depth, average weight of mules and horses was 993 pounds. Thirty-eight states where Spring plowing averaged 6 inches in depth, average weight of mules and horses was 1222 pounds. (See Government Crop Report of February, 1918.) Deep plowing always accompanies plenty of power, even if power is horse power.

21—Tractors decrease amount of man power necessary on the farm. Horse power is used in smaller units than tractor power, hence needs more men.

22—Horses lack ability to meet demand for increased power in rush seasons.

23—The tractor operating on kerosene will produce power at about one-third to one-fifth the cost of animal power.

24—With a tractor, one man can run farm of 160 acres except in harvesting and silo filling time.

25—The tractor releases five acres for food and income production with each horse released.

26—Because the power farmer is a better business man and a more efficient manager, his farming becomes more systematized and profitable.

27—The tractor makes farming more attractive to young men.

28—Use of machinery raises general standard of intelligence in rural communities.

29—It reduces drudgery on farms.

30—Harvesting can be done before grains are overripe.

31—Tractors help to increase the yield per man.

32—The tractor is a portable power plant which transports itself.

33—It relieves worries incident to procuring labor, horses, feed, etc.

34—It often reduces amount of the farmer's investment.

35—The tractor helps the farmer to pay greater dividends on his already acquired automotive knowledge.

FOR SAWING SHORT LENGTHS

An arrangement that can be attached to any standard saw table for the particular purpose of cutting up fire wood into suitable lengths is shown in the illustration. An outfit of this character should be appreciated by farmers, lumber camps, and wood or coal yards. And others who cut up old wood for fuel purposes.—C. C. Spreen.

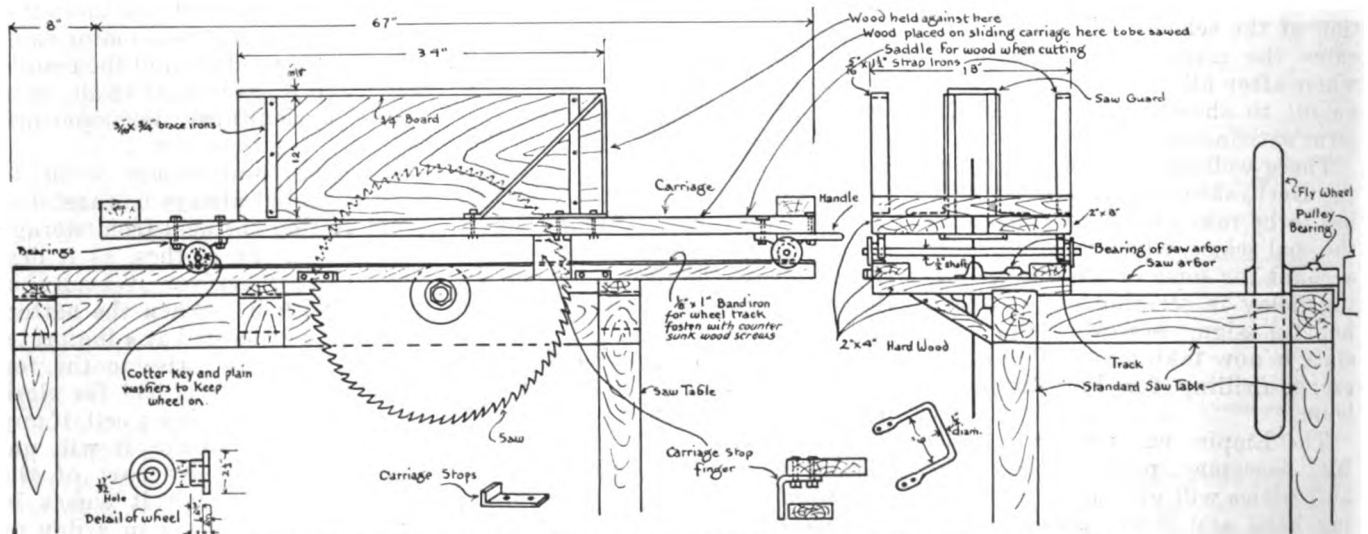

SPECIALLY BUILT SAW CARRIAGE FOR SAWING WOOD INTO SHORT LENGTHS

Remember that the non-successful man is pretty sure to be the petty, domineering one.

THE TRADE ASSOCIATION OPEN PRICE POLICY

A large number of business men are beginning to inquire whether the "open price policy", as practiced by a number of trade associations, is not in violation of the Sherman Anti-Trust Law. The operation of the "open price policy" is this: At the meetings of the Association the contracts entered into by the various members of the Association are open for inspection and each member knows the prices which the other members are getting for their goods.

The law states that "Every combination*** or conspiracy in restraint of trade or commerce among the several states *** is hereby declared to be illegal." In the various decisions under this law it has been held that not only is any agreement illegal which is formed for the purpose of restraining trade or commerce, or of limiting competition, but that any agreement is illegal which in fact does restrain trade or limit competition, whatever may be its avowed object.

In one case it was held that the Government need not prove "that the agreement was entered into for the purpose of restraining trade or commerce, or for maintaining rates above what was reasonable. The necessary effect of the agreement is to restrain trade or commerce, no matter what the intent was upon the part of those who signed it. Purpose or motive is of no moment provided the contract or agreement directly provided for the suppression of competition, or when such a result as a matter of law must necessarily occur."

From these decisions it is clear that the "open price policy" could not be used as a blind to control prices or "divide the business." But assuming that such a policy is decided upon as a legitimate means of promoting the business of the members of any trade association will the members of the association thereby render themselves liable to prosecution under the Sherman Law? And if such prosecution were begun, from malicious motives, would it probably result in conviction?

There is nothing new in the "open price policy." Wherever it is practiced the members of the trade association are doing only what every merchant does, when he displays his goods with a price ticket on them. In fact they are doing less than the merchant, for

they disclose only the prices at which goods have been sold. And producers who have a "fixed price" for their products make known to all, including their competitors, the price at which they sell.

THE "BUG"—A UTILITY LANTERN

One of the principal points of appeal about this lantern is its inexpensiveness. All it costs is a common white tallow candle, which may be secured for two for five cents, an old tin can, a piece of wire for the handle and a little effort. To make this feature cut a hole in one side to accommodate the candle, this being just large enough to hold the candle tightly after it has once been forced in place. The lower end of the candle

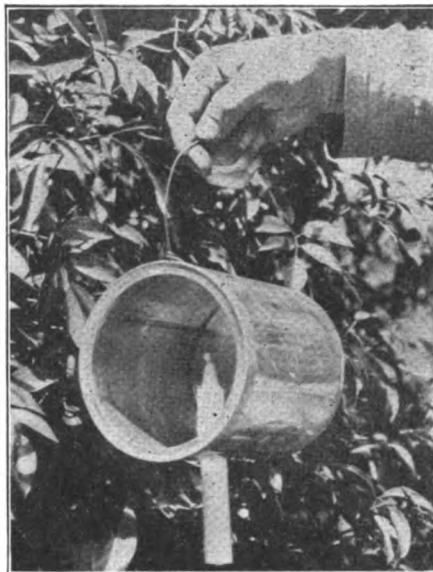

A NEW TIN CAN AND A CANDLE IS
ALL YOU NEED

may be permitted to hang down below the bottom of the lantern and pushed up into the lantern as it burns away. For the handle punch four holes, two at either end of the can and all at the opposite side from the hole containing the candle, which, of course, is at the bottom of the lantern. Arrange the wire handle in place and punch several small holes in the top of the lantern to serve as ventilation, and the feature is finished and ready for service.

Care should be taken to secure a can, the inside of which is bright and clean so that it will reflect the light well. It will be found that it is practically impossible for the wind to extinguish the light of this lantern. —Albert Marple.

Among merchants and manufacturers it is generally supposed that the disclosing of prices to competitors is an evil, to be guarded against whenever possible. Persons are employed to visit the stores of rivals and purchase certain articles for comparison. And the general result of the publicity is to keep prices down to the lowest possible point.

The conditions that govern various lines of trade differ, but it would seem that the "open price policy" should meet approval of the buyer, especially if the buyer is informed as to the prices paid by his competitors. In the history of business secrecy has been one of the strongest weapons of the business pirate, and open dealing the mark of the honest tradesman. There seems to be no reason to think that it will be otherwise in the future.

It is quite certain that if a trade association wished to control prices they would compare prices before the contracts were made, rather than after. That the members of any given association are willing to give this information to each other indicates that they have come to regard business on the high plane of giving service to their fellows, and good service at a reasonable price are concerned only in the giving of instead of giving as little as they good service at a reasonable price, must and getting as much as they can.

In order to secure a conviction it would be necessary to prove either (1) that the object of the Association, or of the agreement entered into by its members, is really to restrain interstate commerce, or (2) that the result of the action of the members is really to restrain such commerce. Both of these are matters of fact which would have to be proved or disproved in any particular case. It is to be noticed, however, that such comparison of prices had an influence on commerce would not, in itself, make it a violation of the law. As Justice Peckham said, "An agreement entered into for the purpose of promoting the legitimate business of an individual or corporation, with no purpose to thereby affect or restrain interstate commerce, and which does not directly restrain such commerce, is not, we think, covered by the Act, although the agreement may indirectly and remotely affect that commerce."

Queries-Answers-Notes



THIS department is the meeting place where you are free to ask for information, answer questions, discuss shop matters and business conditions and any other notes you feel would be of interest to a fellow mechanic. Make use of this Department as often as desired.

We'll Admit It's Some Paper—"I have welded six jobs with the welding outfit I recently asked you about and I give the paper credit for learning me how to use it. In the March, 1917, number you showed a picture and gave instructions for getting the right kind of flame for welding which I followed and find the results all that could be desired.

"Also I want to say that if any mechanic wants to learn how to do things they should subscribe to the Auto & Tractor Shop. Some of these days I am going to write up a few of the kinks and tricks I have learned at the trade."

George Braxton, N. C.

"P. S.—Enclosed find money order for the subscription of W. O. Lawrence. I had already written this letter when I thought of him. He is a mechanic who has just opened a garage across the street from us. All I had to do was just show him a copy and he said he wanted it."

We're Handed Some Bouquets—"Your paper the best yet and and gets better all the time." J. N. Keeney, Nebraska.
"Have sold out my old stand and moved to a new place in the state of Missouri and opened up a garage and repair shop and I have all the work that myself and three men can handle. We do all kinds of repair work and sell supplies. Have received my March number and must say it gets better with every number."

W. C. LeBow, Missouri.

Town Needs a Blacksmith—The town of Fern, Iowa, is without a blacksmith and wants one, according to accounts, and will welcome the location of a competent smith there.

Owing to the fact that the owner of the town's only shop has been compelled to move on a farm the community is now smithless.

Ford Repair Parts—If I remember correctly I saw in a recent number where the Ford Motor Co., had decided to sell their supplies and parts to all garages. Does this apply only to towns where there is no Ford service station?

I am starting a garage and would like to buy my Ford parts from the Ford people. We have a Ford garage in this town. I have been doing some Ford work and have been thinking of putting in a full supply of repairs.

L. Stretton, Illinois.

The Ford Motor Co., through its branches and local dealers will sell Ford parts and supplies to any garage handling general automobile repair work whether or not there is a Ford service station in the town. A discount of 25% from list price is allowed garages on these parts. If the Ford garage mentioned is an authorized Ford agency your business should be done through him as in this way freight and

transportation charges will be saved, otherwise you will have to order from the nearest Ford branch, which, in your case is located at 4100 Forest Park Blvd., St. Louis, Mo.

Shod 45,000 Horses—Fred Zugenbush of Ohio, claims a record of shoeing 45,000 horses. Mr. Zugenbush has been a blacksmith for 45 years and was a delegate at the recent convention of Ohio horseshoers held in Cleveland.

President J. W. Hagerman is authority for the statement that the automobile and truck has not hurt the horseshoeing business.

How to Treat a Hammer Handle—I have read somewhere that the life of a hammer handle can be prolonged but I have forgotten how this is done. Can you give me any information on the subject?

B. Roth, Pennsylvania.

Remove the wedges and head of the hammer and soak the end of the soaked in linseed oil for three or four days. The handle should then be removed from the oil, wiped dry and allowed to dry out for a week before the head and wedges are replaced. A surprising toughness and life is given the handle by this treatment.

Engine Skips Fire—A Ford engine that I have been working on misses fire some times and without any apparent cause and I am at loss to understand what is causing it as the timing and carburetor adjustments are all O. K.

J. C. Zillig, Oklahoma.

Moisture or grease on the surface or the interior of the distributor housing will sometimes cause more or less miss-

ing because the high tension current skips across the surface of this foreign matter instead of going through its regular channels. The obvious remedy is a thorough cleaning of the distributor both inside and out. The presence of moisture may be explained by the condensation of moisture from the air drawn through the engine by the fan on a damp day while grease and oil comes from the spray that is thrown out by the engine.

Back From the War—Having been discharged a short time ago from the U. S. Air Service and back at my own work blacksmith and horseshoer I notice that my old customers have nearly all bought cars since I enlisted. This will mean less shoeing and buggy repair work so I have made up my mind to learn the auto repair trade so I ask you for information as to what school is the best and most reasonable and would it pay me to go to an auto school or take an auto school course. I do not get much time to study and I do not think that a correspondence course would be as good as a repair school where one does the actual work.

So here's hoping to hear from you. I still receive the paper and it's just as good as a course from any correspondence school. John Faber, Central Lake, Mich.

Lining Up Front Wheels—What is the correct way to line up the front wheels of an automobile?

C. S. Rummel, N. J.

In lining up front wheels adjust the tie rod so that the toe in or gather of the wheels is about a half inch or a quarter inch for each wheel, that is the wheels come together in the front that much. The camber or spread at the top should be the same, that is the distance from one wheel to the other should be a half inch less at the bottom than at the top. While this distance may vary slightly with various cars the above is a good average.

Starter Trouble—Recently I had an experience with an electric starter that has left me wondering. The starter operated alright but the engine would not take fire and in operating the starter it suddenly refused to work. Finally I tried cranking the engine by hand and the starter worked successfully. Can you give me any information as to why the starter stuck?

Guy B. Huston, Minn.

The Bendix drive gear with which the starter is doubtless equipped stuck in the

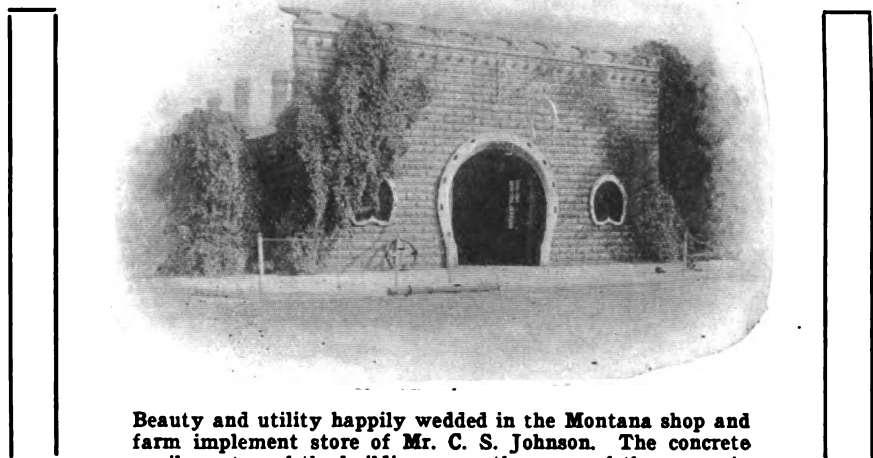

Beauty and utility happily wedded in the Montana shop and farm implement store of Mr. C. S. Johnson. The concrete anvils on top of the building carry the name of the owner in large letters while the form of the door and windows is a unique and forceful suggestion of the owner's business.

engine flywheel and when you turned the engine over with the crank this starter gear was turned back on its shaft thus releasing the starting motor. The same effect would be produced by pushing the car backwards. This is usually a sign that the threaded shaft of the starter needs lubricating.

12,960,000 Magneto Sparks to Reach Europe—A "fact-fiend" who is also an aeronautical enthusiast, submits the following.

The twelve cylinder Rolls-Royce engine used on Harry G. Hawker's Sopwith biplane with which he hopes to fly across the Atlantic Ocean from Halifax to England is fitted with four magnetos for ignition, entirely independent of any batteries. Only two magnetos will be used, one for each six cylinders. The extra two magnetos are for emergency purposes only. All twelve cylinders fire their compressed gas once every second revolution of the propeller, thus six cylinders fire every revolution.

The normal revolutions of this engine are 1800 each minute, or 108,000 an hour. For a journey of 2000 miles at 100 miles an hour six cylinders firing for each turn of the propeller will mean 12,960,000 hot sparks from the two magnetos at the rate of 648,000 an hour. Should two twelve-cylinder engines be used the total number of sparks will then be 25,920,000.

The confident dependence of Mr. Hawker on his magnetos is not to be wondered at when it is recalled that every airplane engine in the world, with the exception of one type, is magneto-equipped, and the magneto has proved itself ideal for the difficult airplane services required in actual warfare. He cannot under any circumstances afford to take chances of failure when all else is at stake. He has to have absolutely dependable ignition, which will never miss fire or go dead.

George W. Morrison.

Safety First Measures for Drivers and Children.—It is up to the motorist to watch the children on the streets and upon him is the burden of avoiding accidents. However, the youngsters can well be schooled in the simple rules of "safety first."

"Give the children the advantage of every doubt and there won't be so many accidents to the little tots." "When children are on the side-walk or curb, the driver should swing around as much as possible and lessen the speed so that if a child should do his best to throw himself in front of the car, it could not be done. Children at play may suddenly break from the group and run at top speed into the path of a car and the motorist should always keep this in mind. Expect the unexpected and you'll be safe.

"There are a few rules that the children can observe that will decrease the number of accidents, but the motorist must never feel that the responsibility rests at all with the child."

1. Look in both directions before stepping off the sidewalk. The left is most important because all traffic should be coming from that direction.

2. Never walk behind a street car without looking carefully for automobiles or other street cars coming from the other direction. It is much better to walk a little farther to the corner before crossing.

3. When possible always go to the corner where the traffic policeman is on duty. He is your friend.

4. When more than one child is crossing the street, hold hands tightly, don't run and DON'T SEPARATE. The driver can miss you if you become confused, providing you stay together, but if you separate, one of you is almost sure to be struck.

5. If a car is standing at the corner or moving slowly some distance away, LOOK THE DRIVER IN THE EYE to make sure that he sees you and to learn what he is going to do. Don't look at the front of the car. LOOK AT THE DRIVER.

6. When streets are slippery, don't take a chance in crossing just because a car is moving slowly. A quick stop is impossible for the car, and your action may cause the car to skid and become unmanageable, thus endangering many lives including your own.

7. Don't read letters or books when crossing the street. Don't talk to your



If anyone doubts that the auto repair and accessory business pays let him take a look at this Mississippi establishment and ask W. F. Hardtner, for the man with his hand on his left hip pocket is none other, what his experience has been.

friend but keep your mind on the fact that you are crossing a street where there is danger and you must be alert.

8. In playing ball or tennis, if the ball goes into the street, don't run after it without stopping first at the curb to make sure that there are no cars approaching.

9. Cross the street at street corners. In many cities there is a fine for anyone crossing between corners. This is called "jay walking."

10. Don't play in the streets and don't roller-skate in the streets.

11. If the road is the only place to walk to school, walk on the left side facing the traffic. If you walk on the right side, you will be in the path of cars approaching from behind.

12. Don't "hop on" behind trucks or cars. The greatest danger is in getting off without being able to see in all directions.

Can You Tell Him How—I would like to hear from some of the trade in regard to tempering cold chisels and cold cutters. I have a lot of trouble in getting them to stand up. The chisels are used for cutting $\frac{1}{2}$ and $\frac{3}{8}$ inch nuts and the cold cutters for cutting steel rails.

L. E. K., Pennsylvania.

Dealer Demonstrates at \$4 Per Acre—Kyle Elliott—who is the Elliott of the Elliott Tractor and Truck Company—is one of these resourceful persons who not only has good ideas, but puts them to work.

Things were slow opening up right for him this Spring on account of the incessant rains which gummed things up in Alabama, Georgia and all points south.

Between showers Mr. Elliott conceived the idea of using the small farmer to pay for the sort of demonstrations which would sell tractors to the big land owners.

So he let it be known that any small farmer who had a little patch he wanted plowed and who hadn't been able to do enough work to get his crops in with his mules, could save himself from a lost crop by paying the Elliott Tractor & Truck Company \$4.00 per acre for plowing, with a proportionate charge for fitting.

A lot of little farmers took advantage of the opportunity and got their crops in while their more prosperous neighbors were wishing that they could do so.

Mr. Elliott soon began to have calls from the larger farmers asking for the same service, but he was not interested in doing work on a custom basis for anyone who should have a tractor of his own.

In this way he not only got some good advertising for the tractor he sells which paid for itself and at the same time did his community a service by getting crops planted under difficulties, but he sold tractors to larger farmers who saw the advantage of his tractor and who recognized that it was a money maker for them, particularly at times when quick work was necessary in getting in a crop.

Incidentally the Elliott Tractor & Truck Company took in something like \$300.00 during the Winter for services rendered in pulling trucks and automobiles out of the mud with their tractor.

Can't Use Plane Motors in Cars—

One of the questions now being discussed in automobile circles is the possible effect of aircraft engine development in automobile practice. Henry M. Crane, chief engineer of the Wright-Martin Aircraft corporation, states that since airplane engines are not subjected to the sudden road shocks suffered by automobile engines they are built with a much lower factor of safety and receive extra care in machining and assembly. In airplane engines an effort is also made to secure the greatest possible output of power per cubic inch of piston displacement, some engines developing up to 45 horsepower per cylinder, while in automobile engines weight is of less importance and freedom from vibration quite necessary.

On the whole, Mr. Crane does not think airplane engine designs will have any effect in motor cars for passenger and freight service.

Alcohol as Carbon Remover—As a means of removing carbon from my engine it has been recommended to me to inject denatured alcohol through the air inlet of the carburetor while the engine is running. Will you kindly inform me if the alcohol can in any way injure the engine and how it will affect the lubricant on the cylinder walls.—H. D. Hannah, N. J.

We have never had any experience with denatured alcohol as a carbon remover. It is questionable as to whether it would act as a solvent for the carbon in the cylinder. So far as the action on the oil goes you would not have anything to fear from testing with a little of the alcohol in the cylinders.—C. S. R.

AMERICAN BLACKSMITH AUTO & TRACTOR SHOP

VOLUME 18

JUNE, 1919

NUMBER 9

BUFFALO, N. Y., U. S. A

Established 1901. Published Monthly at the Sidway Building, Buffalo, N. Y., by the

AMERICAN BLACKSMITH COMPANY

Incorporated under New York State Laws.

WILLIAM F. WENDT, *President.*

WALTER O. BERNHARDT, *Editor.*

SUBSCRIPTION PRICE:

For \$1.00 per year, payable in advance, The American Blacksmith, Auto & Tractor Shop will be sent, postage prepaid to any postoffice in the United States. To Canada, \$1.25; to other countries, 6 shillings. Reduced rates to clubs of five or more on application.

Remittances may be made by money order, express order or checks payable to the American Blacksmith Company. We will also accept uncancelled postage stamps or currency, but for safety these should be sent by registered mail.

Subscribers should notify us at once of non-receipt of paper or change of address. In latter case, give both old and new address.

Correspondence on all smithing subjects solicited. Always give name and address, which will be omitted in publishing, if desired. Address all communications to the

"AMERICAN BLACKSMITH COMPANY"
BUFFALO N. Y.

Copyright W. F. Wendt Publishing Company, 1919 "

Cable Address: "Blacksmith, Buffalo"



PARK BENCHES, ETC.

Unemployment may bring a man to the park benches directly but the indirect reason the bread line, the flop-houses and the ranks of the discontented are always filled with the derelicts of incompetence is because they lack either education, skill or ambition—in other words just plain lazy and it is always this element that is the first to cry out that they are not being given a fair chance.

Brains are at a premium today and the time has come when the man with the brain that God gives him but lacking either the ability or the desire to use it can only be used as a hewer of wood and a drawer of water for the man who knows how to use his brain and takes advantage of his opportunities.

The Socialist, the I. W. W., the Bolshevik and others of the breed would have us believe that this arrangement is all

wrong—that the shiftless, the ignorant and the lazy should have the chance to run things generally.

Also, according to these doctrines the "worker" should have all the profits of his work which is alright in theory but can poor in practice—even in Russia where the sixteen year old minds in men's bodies have, for the time being, the power to do anything that the tolerance of God's permits them to do.

The occupants of the park benches feel that society in general and the "capitalists" in particular are responsible for their being in the down and out class when only themselves are at fault.

After all it isn't so much a matter of education as it is a matter of thinking. Many a man who can hardly read or write his own signature has risen to wealth and position, not because he was educated, in the strict sense of the word, because he used his brains for thinking about getting what he wanted and having ambition enough to scratch his own gravel, yet the Socialists tell us that this man is a "capitalist" and therefore, he receives the anathemas of the "worker crushed beneath the heel of capitalism".

A man is only worth a dollar a day from the neck down—from the neck up he is worth whatever he cares to make of himself. The man with ambition succeeds—the man without it winds up on the park benches with his whine that he is the victim of the "capitalists," and our "social system."

TIRE PRICES DROP

Several of the leading automobile tire manufacturers have advertised a considerable reduction in the list prices of their products, that amounts to approximately 15%.

This reduction is one that is bound to show results in larger sales.

CONTENTS—JUNE, 1919

| | |
|--|-----|
| Growing Pistons | 211 |
| British Builders Slow | 213 |
| Wartime Influence on Truck Design. | 214 |
| Miscellaneous Tractor Repair Hints. | 215 |
| Straightening Auto Rims..... | 217 |
| Information Regarding Chisels..... | 218 |
| Benton's Recipes..... | 221 |
| Kink Page | 223 |
| Applying Connecting Rod Bushings— Non Spilling Funnel—Valve Seating Tool—Tool Tray for Creeper —Polished Pipe Wrench—Adjustable Clamp Flexible Shaft—Keeping Bearing Cool—Gas Hose Rack— Valve Grinder | |
| Balancing the Overhead..... | 224 |
| Storage Battery Explosions..... | 225 |
| The Scooter in London..... | 226 |
| Modern Heat Treatment of Steel... | 227 |
| Two Ton Truck Body..... | 228 |
| Sharpening Fine Cutlery | 229 |
| Drilling True Holes in Metal..... | 230 |
| Selling Farm Implements..... | 230 |
| Acceptance of Offer Completes Contract | 232 |

DON'T GIVE MONEY TO AGENTS

The American Blacksmith, Auto & Tractor Shop DOES NOT employ subscription agents. Any person representing himself as such is an imposter and should be so dealt with. Notify us immediately if anyone claiming to represent this journal calls upon you.

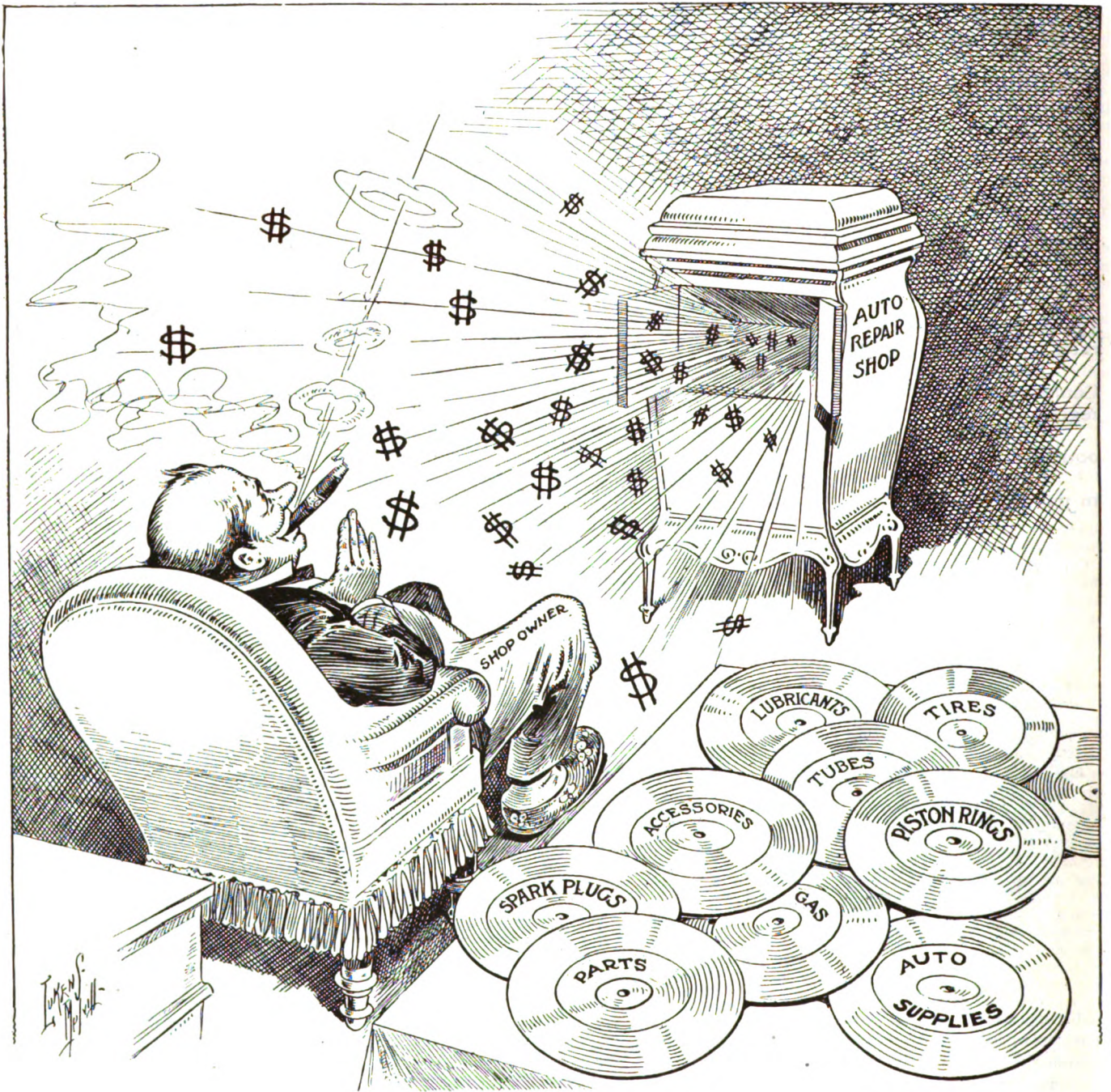

After Farm Implement News

TRY THESE RECORDS ON YOUR BUSINESS VICTROLA

Cylinder and Piston Jobs in the Welding Shop

David Baxter

WORN automobile and gas tractor engines may now be renewed or repaired without the expensive purchase of new pistons and without the expensive machinery for reboring the old cylinders, also without the cost of machining new pistons, not to speak of the saving of time required for the machine work. Where all this was formerly necessary, the job may now be accomplished in a few hours, putting the engine back in service with a minimum of delay and expense.

This new method is called "growing pistons", which, while figuratively speaking, is literally true. The old pistons are enlarged or "grown" to fit the same cylinders. All that is necessary to do to the worn cylinders is to "straighten up" the bore; that is, grind out the high places. This grinding is done by hand with a large, improvised brace as shown in picture No. 1. The details of this brace and borer are illustrated in the accompanying drawings. To construct one of these tools: first take a bar of $\frac{7}{8}$ inch round iron and bend it in the form of a common carpenter's brace. Forge an eye on one end large enough to accommodate the piston pin; it need not fit the pin snugly. The other end may be merely ground smooth or fitted with a flat socket knob like a carpenter's brace; the chief requirement is strength and good leverage.

Next, secure a discarded piston about the size of the cylinder to be bored. Saw off the solid or head end of this piston. Then saw a wedge shaped section out of the side of it. See drawing. The sawed section should be about $\frac{3}{8}$ of an inch wide at the top and $\frac{1}{4}$ th of an inch wide at the bottom; the smaller dimension at the former solid end of the piston. It will now be found that the sawed piston will spring outward if a larger wedge is inserted in the wedged slot, and tapped in with a light hammer; this enables the mechanic to enlarge the split piston, or make it smaller in diameter, as he desires. The larger wedge should be made of steel an eight of an inch larger in every way than the sawed out wedge; it

should be about two and a half inches longer. The piston pin is inserted through the eye of the brace and the steel wedge is placed in the sawed opening; the hand borer is now ready for use.

The first step in the new process is to rebores or line up the worn bore of the cylinder. This is more or less tedious in some cases but most cylinders are readily fixed. Once in a while a cylinder is found that is too badly worn to pay to straighten it, or "lap it out" as the term has come to be called in the repair man's vernacular.

The bore of a cylinder usually wears low at each end so that it is only necessary to grind out the high

Then tighten the piston by tapping inward on the wedge. The piston is allowed to turn rather freely at the start and is tightened after several turns of the brace. Then the brace is kept turning round and round while the wedge is driven inward when necessary. Care should be taken to see that the boring head turns squarely in order to keep the bore straight. It may be the device will need to be withdrawn from time to time to apply more grinding compound. And it may be necessary to use a pipe wrench on the the stem of the brace to help turn it. Here is the whole thing: keep turning the brace until the bore is straight. Sometimes it is remarkably easy and again it requires stubborn effort.

After the cylinder is straight the next step is to "grow" the old piston, or enlarge it to fit the bore. Or, the enlarging may be done while the boring is in progress. The principle of the "growing" process is easily understood when one knows that cast iron enlarges when heated to a certain temperature and held there a given length of time; the time is yet somewhat a matter of guesswork because the structure of the iron varies in different makes of pistons. It is unusual, however, for the piston to get too large with the first heat treatment. Sometimes it takes four or five heats to enlarge the piston enough to fit the cylinder. As far as the writer is aware there has been at least one instance where a set of pistons were enlarged $\frac{1}{64}$ th of an inch; which is enough for nearly any worn cylinder, this set required but four heatings. However, the process is open for a little experimenting on the part of the individual repair shop.

The enlarging of pistons is particularly suited to the oxy-acetylene welding shop, because they have handy facilities for heating various articles to any desired temperature. But it is not essential to possess any special preheating or annealing equipment. If an annealing box is available it will simplify matters, otherwise the arrangement illustrated in picture No. 2 will serve the purpose. This

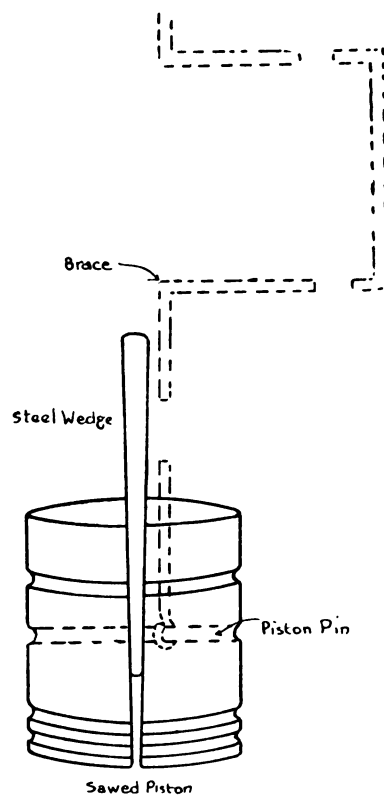

HOW THE LAPPING PISTON IS SAWED OFF AT THE BOTTOM. THE EXPANDING WEDGE AND THE APPLICATION OF THE BRACE TO THE WRIST-PIN

place in the center. This is done with the hand borer just described. To accomplish the feat, first smear grinding compound on the wedged piston and insert it in the bore.

device consists of a small ovenlike structure made of fire brick, with rods or grating for the pistons to rest upon, and covered with asbestos paper. This covering should have holes in it through which the

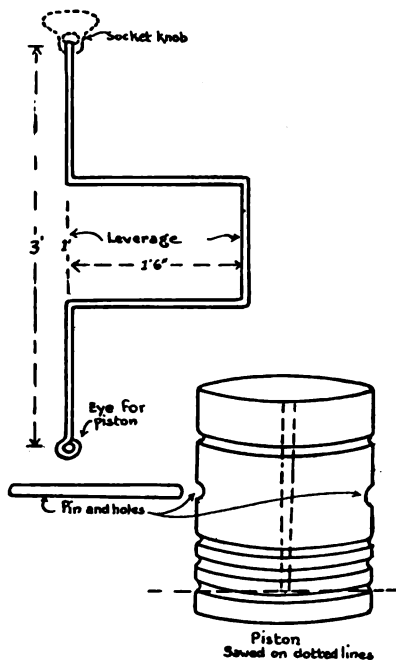

THE BRACE USED AND HOW THE LAPPING PISTON SHOULD BE SAWED

workman can watch the heating pistons, to tell when they are hot enough. A piece of perforated sheet iron will do as well as the asbestos.

The brick heater is built over a gas jet or an oil burner arranged so that the heat will spread evenly over the interior. A charcoal fire can be used but is harder to govern. To do the heating: after first cleaning the pistons of all oil or dirt place them with the solid end down on the grating of the heating oven; then light the gas or fire underneath the pistons. Heat the pistons until they become bright red; almost white hot but not enough to reach the melting stage. Be sure the temperature is the same all over the pistons; bright red. Hold this heat stationary for from 15 to 45 minutes. Then turn out the fire and cover the heater with asbestos paper and allow the whole thing to cool slowly. The covering is not removed until the pistons are almost cold.

When first trying the method it is better perhaps to hold the heat only 15 minutes, gradually increasing the time if the pistons do not enlarge enough the first heating.

When the pistons are cold try them in the straightened cylinder; if they have not "grown" enough repeat the heat treatment.

It will be noted that the pistons which have been heated appear to have lost their metallic quality. This is due to oxidized iron forming a thin skin over the surface of the casting. It must all be removed before the piston is fitted to the cylinder. A sharp file will remove the scale quite readily although some of it is very hard. If the piston is then too large it may be necessary to again "lap out" the cylinder; if it is too small the piston is heated once more, estimating the amount of heating by the size of the piston.

This method of "growing" pistons is not as good as having the cylinders rebored and new pistons cast, nor should it be confused with the latter, but for a cheap, quick repair the thing is alright, giving good satisfaction wherever properly executed. The method is for pistons made of cast iron only, which is the usual metal employed. Some welders have trouble in growing pistons on account of the pistons not being round after being annealed. Sometimes it is even necessary to machine them in a lathe. But usually they can be "ground in". This is done with the same brace used for "lapping out" the cylinders. Except that the grown piston is used instead of the one with a section removed. The reason for the pistons not coming out round is that the heating has not been properly executed, and on account of the heavier bosses on the inside of the pistons retaining heat longer than the shell. Also on account of these bosses tending to grow more than the shell. These difficulties are usually augmented by improper heating and cooling. It is hard to give any set rules for governing the annealing. Perhaps the best way is for each individual welder to learn by experiment and experience. Before attempting to do actual "piston growing" he should secure several different sizes of old discarded pistons with which to practice until he becomes more proficient. He can take these old pistons and try different heatings and coolings until he is somewhat able to judge the requirements. He should soon be able to regulate the annealing process enough to be able to control the shape of the pistons to a great extent.

I have seen a little experimenting done with a pair of false bosses wedged in positions opposite the piston bosses. The idea of this was to balance the heat on the inside of the piston. This idea may be worked out so that it will actually control the wrapping of the pistons. It will be well for every welder to give the matter some thought for as the old saying goes two heads are better than one and where a larger number are engaged in thinking on a given subject some one is bound to evolve a good idea.

CARE OF ANTI-FRICTION BEARINGS

The anti-friction bearings in a tractor should be examined once or twice a year, according to a bearing specialist. In the spring after the heavy work has been finished



METHOD OF USING THE BRACE AND PISTON FOR LAPPING OUT THE CYLINDERS

is a good time, and again in the fall when field work has been completed. When the bearings are removed, they should be cleaned well with gasoline or kerosene and covered liberally with a good grease. When replacing roller bearings in traction wheels it is a good plan to put a supply of grease in the hub of the wheel before replacing it on the axle or spindle.

The Pictures Show that Grease Cups Do Not Always Lubricate

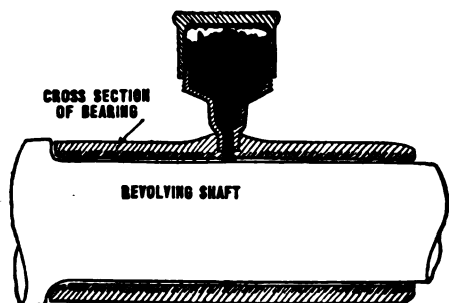

NO. 1. GREASE CUP NOT PROPERLY FILLED. THE FIRST FEW TURNS WILL NOT SEND GREASE INTO THE BEARING, BUT WILL COMPRESS IT INTO THE CUP

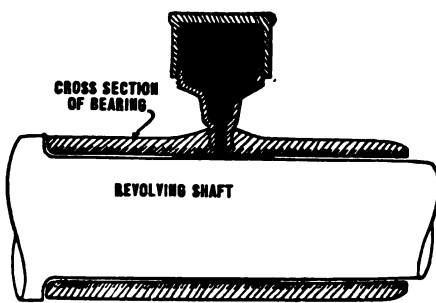

NO. 2. ANOTHER CARELESS WAY OF USING A GREASE CUP — ENTIRE BEARING IS NOT LUBRICATED

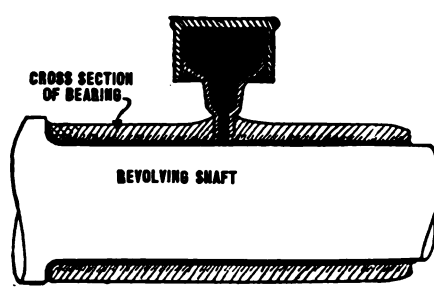

NO. 3. THE PROPER WAY TO LUBRICATE WITH A GREASE CUP. NOTE GREASE FULL LENGTH OF BEARING AND READY TO COME OUT AT ENDS

BRITISH BUILDERS SLOW

John Y. Dunlop

The British public is becoming rather impatient at the failure of the home makers to provide them with new cars and it is beginning to be suggested that if they cannot oblige they should not object to importers supplying the necessary chassis.

The makers in England are giving nothing away regarding their intentions and difficulties with the result that the public, with or without justification, feels that it is not being fairly treated. It is considered that only foreign competition can force the British makers to meet the popular demand.

Of course there is another element of the motoring fraternity that is inclined to believe that within six months the factories will be working under normal conditions and that if they are not, then the industry deserves to lose trade as the penalty for its lack of push and go.

Personally, I am afraid that the true cause of the delay is caused by the makers being hampered with government orders for war material that have not been cancelled, the restrictions on materials and the uncertainty of labor costs. All these things have made reconstruction a very difficult matter in this country.

In their complaints against the industry, the motorists are ably seconded in their protests by the retail trade which, after four exceedingly lean years are hungry for something to sell

and after all, however desirable it may be to foster a wealth producing industry the consumer has some title to consideration that should be respected.

ASSEMBLING MAGNETO GEARS

Since the magneto operates at a speed in direct ratio to the crank shaft, when overhauling an engine with magneto ignition great care must be taken to replace the magneto gears properly when assembling. Incorrect attachment of the magneto is sure to lead to trouble. The mistake is also made of over-oiling the magneto, and practically 90 per cent of all magneto trouble comes from this source. One or two drops of light sewing machine oil a week should be sufficient.

PLOW BOTTOM DESIGN

There are many factors to be considered as well as the shape of the mouldboard before a plow will scour satisfactorily. Material used, treatment in manufacture and evenness of surface, are some.

Soft spots and depressions in the mouldboard are oftentimes the cause of failure of a plow to scour. This bears out theory that the successful scouring of a plow depends much upon the equal pressure of the earth over all points of the mouldboard and shares. If scratches and depressions are made in the plow by sand and rock, the pressure of the soil is no longer uniform and trouble results. Thus it becomes evident that the steel of which the plow is made must be harder than the abrasive material in the soil. An attempt to make a steel of this kind led to the invention of chilled metal for plow bottoms.

This metal will withstand the erosive action of sand which is present to a more or less extent in most of the soils in this country. It makes a heavier plow bottom than steel, but where the soil has a gritty nature, the draft is lighter on the team, because of the fact that it scours better. On the other hand it is impossible in the manufacture of chilled plows to eliminate all depressions in the surface of the mouldboard, a difficulty which is more easily overcome in steel mouldboards. For this reason where the soil is free from gritty material the steel mouldboard is more preferable.

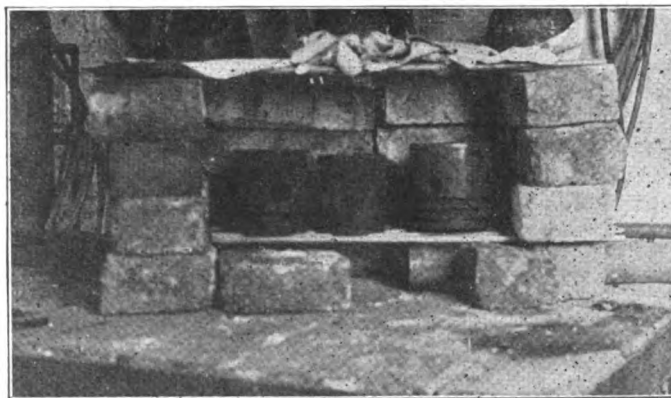

THE HEATING OVEN FOR "GROWING" PISTONS. THERE ARE CASES ON RECORD WHERE PISTONS HAVE BEEN INCREASED 1/64 WHICH IS USUALLY SUFFICIENT TO MEET ALL REQUIREMENTS FOR OVERSIZE PISTONS

When preheating an aluminum crank case I determine the proper temperature by rubbing the case with common wire solder. I find that when the solder melts the case is at the right heat. I never have trouble with them.

WARTIME INFLUENCES IN PEACETIME TRUCK DESIGN

Requirements for special features that were necessary in motor trucks built for the government war needs are being incorporated in peacetime truck models. Manufacturers of trucks realize that some

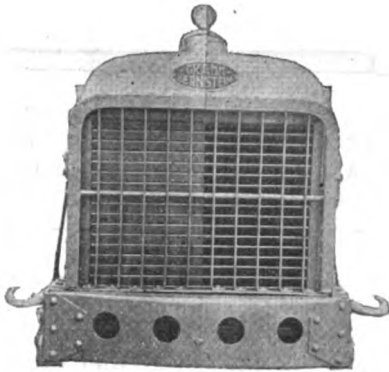

MOTOMETER, RADIATOR GUARD AND SHUTTER AND THE PIG-TAIL TOWING HOOKS ARE WARTIME IDEAS THAT WILL SURVIVE IN TRUCK CONSTRUCTION

of the features of the government's war trucks are worth adopting for peacetime service and are building their trucks accordingly, with radiator shutters, radiator guards, towing hooks, drawbars, and other sensible ideas.

The photographs show a recent model that has these departures from conventional motor truck construction incorporated in it.

One of the views shows a composite photograph of the radiator with the radiator shutter opened on one half and closed on the other half. The motometer which has hitherto been found only on passenger cars now makes its appearance as regular equipment on the commercial cars. The radiator guard while not new to peacetime truck design is sufficiently novel to merit mention. This guard is the same as that used on the government's Liberty trucks and is a separate unit and is bolted to the frame independently of the radiator.

The pig-tail towing hooks on both sides of the frame in front are for towing purposes in case the car should become disabled and this is a much better idea than hitching the towing rope around the front axle or spring. The rear end of the frame is provided with a spring draw-bar for towing trailers or other disabled cars, a feature that will be greatly appreciated by truck owners.

The tail light arrangement is worth particular mention inasmuch as the tail lamp is placed inside of the frame and is thoroughly protected by the frame cross-member.

Aside from these additions which will doubtless become a part of the regular construction of the heavier truck models the war has influenced truck construction and design but slightly.

TO REPAIR A LAWN MOWER WHEEL

In cities where concrete curbs are plentiful broken lawn mower wheels are numerous, especially the outer rim. This can be very easily and quickly repaired by following these few instructions: Cut and file out broken rim till you are half over a spoke, at each end of broken gap. Now take a piece of flat iron of the same width and thickness as original rim; lay on anvil and place a quarter-inch piece of tool steel across it and hit with a hammer and you have made a corrugation; continue this process, spacing the corrugations about one-fourth-inch apart till you have taken in a length sufficient to fill the opening in the wheel. Now open up your vice about four inches and peen the piece in shape of rims. Care must be taken at this point to get patch exactly round, as the slightest deviation will show when grass is cut.

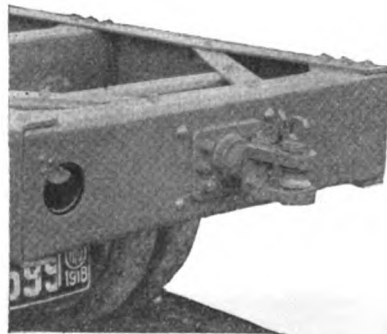

THE PROTECTED TAIL LIGHT AND SPRING DRAWBAR

After shaping, bend up two spokes out of one-eighth-inch iron, fit to outside of wheel and patch rivet to patch first; place on wheel, rivet down solid and job is done. Remember, in all patch jobs always counter-sink both sides of every rivet, and after riveting grind or file off all heads.

To remove inserted mower blades, fasten blade in vise very tightly over blade you wish to remove. Edge or point down; let vise jaws



AN ALL AROUND FURNACE

The furnace shown in the accompanying illustration serves three purposes at the same time. Each of the men is heating steel: one in the lead bath for hardening, another in the semi-muffle furnace for hardening, and another in the combustion compartment for forging. A single burner serves all three. Correct temperatures are obtained with ease.

rest on the rivet head you wish to cut. Now strike sharply with a heavy hammer on top of blade you wish removed, and the blade will shear off the two rivets that hold it and fall out.

TO CLEAN GASOLINE BLOW TORCHES

Take down head completely. Brighten all needle points of valve with a strip of extra fine emery cloth. Place all brass parts in a ladle or shovel and heat till red, drop in cold water. This loosens all carbon deposits and gives brass original color. Now reheat till all moisture is evaporated, take wire and clean inside of all parts, a bicycle pump is convenient to blow loose carbon from the parts. If too much flame comes from burner, take a small hammer and close the opening in the end of discharge. If you do this you must also file a little off the point of your needle valve. The reason for this is that the needle valve would, when turned off, make opening as large as before. Now reassemble all parts, taking out all old packing and repacking with wick abestos, or if not exposed to heat any ordinary packing, even cotton string comes in handy. Tighten up all connections and job is complete.

Build Now

GOOD ROADS AND SEE HOW QUICKLY GOOD TIMES WILL ROLL DOWN THOSE ROADS

U. S. Dept. of Labor
W. B. WILSON, Secretary.

Miscellaneous Tractor Repair Hints

TRACTOR construction differs somewhat from automobile construction particularly in the size and the location of some of the parts and in the arrangements of the engine. In automobiles the universal engine arrangement is parallel with the frame but in a great many tractors have the engine and the crankshaft placed at right angles to the frame. Otherwise the machinery of the tractor is, to all intents and purposes the same in all respects as it is in the automobile and the same repair methods are used in making

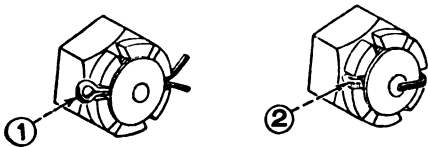

1—THE WRONG WAY TO FIT A COTTER PIN. IT WILL EVENTUALLY WORK OUT

2—THE RIGHT WAY TO INSERT A COTTER PIN. THIS PIN CAN NEVER DROP OUT

tractor repairs and it is the purpose of this short article to take up briefly a few repair ideas that can be applied either to the tractor or to the automobile and accordingly the main tractor bearings will be the first subject.

To determine if the main bearings are loose, place blocks under the flywheel so that a lever can be applied on the under side of the flywheel rim as shown in the illustration, and test by carefully bringing leverage enough to determine whether the crank shaft is loose in the bearings, by placing one hand on the fly-wheel hub and cap. Great care should be taken to see that too much force is not used in which case the crank shaft might be sprung out of line and additional trouble caused.

In fitting on castle nuts a great many repairmen are more or less careless in the way they fit the cotter pins. Illustration No. 1 shows a poor way to fit a cotter pin. The head of the pin is not in the slot of the nut and is turned wrong. The ends are not split properly and are turned wrong and this combination will soon work loose and the pin will drop out and the inevitable result will be a loose if not a lost nut.

The illustration No. 2 shows a proper and workmanlike job. Observe how the head is pounded down firm with a snug fit into the slot of the nut. One end of the cotter is turned back over the end of the bolt and the other end is pounded down. The cotter should be tight. There's not a chance in the world of this cotter pin working loose.

Tractor wheels need more or less attention at intervals and special attention should be given to the spoke rivets of both front and rear wheels. When traveling over crowned roads and hard, uneven ground, tremendous pressure is placed upon the wheel rims, causing the rivets to work loose at times which if neglected will lead to more or less difficulty. Inspect the rivets carefully and regularly and if rivets appear to be loose they should be tightened by holding a heavy sledge or weight against the head and pounding the rivet spread down on the tire until the rivet is solid. Tight rivets prevent cracking of rims and the breaking of spokes.

A few don'ts in regard to the ignition system are also in order:

Don't solder new contacts to old parts as solder spoils the contact. In replacing contact points get entire contact points from the maker.

Don't get busy to adjust the breaker box as soon as trouble develops, the trouble is rarely found in there. Take time to check up

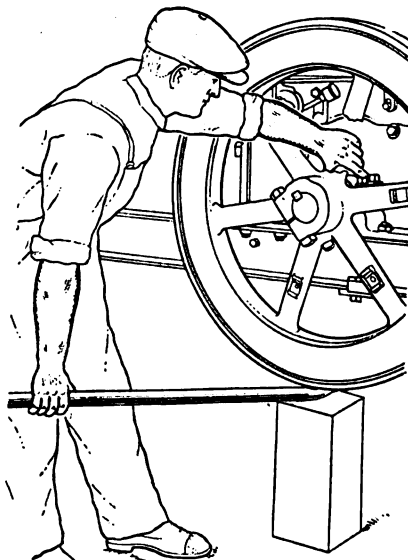

TESTING FOR LOOSE MAIN BEARINGS

the difficulty and in nine times out of ten the trouble will be located elsewhere.

Don't tinker with the circuit breaker adjustment unless the points either fail to separate or the gap is too great, the average distance of the points is about 1/64 inch.

Don't fill the breaker box with grease or oil.

Don't hammer on end of magneto shaft, or attempt to force gears or

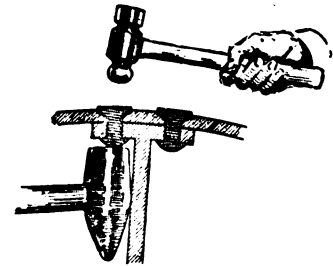

KEEP THE SPOKE RIVETS TIGHT

coupling on if too tight, as this is likely to put bearings out of adjustment.

Don't take off the magneto magnets. When disassembling a magneto, a keeper must be placed across the magnets before their removal from the magneto. Remagnetizing magneto magnets is rarely necessary unless a battery current has been accidentally shunted through them. If for any reason it should be necessary to remagnetize or repair a magneto, return it to the factory unless the services of a competent magneto man can be obtained.

Another point that might be touched on without any harm and that is that spark plugs should not be screwed in too tight as it is likely to burn in so that it will make removal of the plug impossible without ruining it.

A waxy substance is deposited in oil pipes and leads by some oils and may cause a serious stoppage in the flow of lubricant. A good way to remove the deposit is to disconnect the pipe and immerse it in gasoline for a day or more. This will soften the material so that most of it can be blown out with a current of air from a pump. Running a wire through the pipe will also help.

When the starting motor for any reason lacks power to turn over the crankshaft it may be made more efficient by coupling on another storage battery, connecting it in multiple so as not to increase the voltage. If the conducting wires are of sufficient size from the battery to the motor there will be quite a gain in power output.

THE BUILDING AT THE LEFT IS THE BLACKSMITH AND MACHINE SHOP OF THE VARIETY MACHINE WORKS AND THE NEW BUILDING WAS MADE NECESSARY TO HANDLE THE FIRM'S AUTO REPAIR BUSINESS



"Variety Machine Works" reads the sign on one of the most thriving institutions in a town of about 500 down in Mora county, New Mexico, conducted by C. E. Anderson & Sons. From the pictures the reader concludes that "Variety" constitutes not only a large proportion of the "spice of life" for the proprietors but also a large part of their satisfactory and growing income.

This establishment has a fully equipped machine shop; if it's anything in wood or metal you can get it made here and wagon and carriage work as well as horseshoing

are by no means incidental to their other mechanical activities. The oxyacetylene welding branch of the business is considered one of the firm's best time savers and money makers.

When the Andersons located in this part of New Mexico, about ten years ago, the surrounding country was mostly government land. Besides having a live and growing business along the lines just mentioned that keeps the firm pretty thoroughly occupied the Andersons find time to operate their ranches near town and also, being expert threshermen, they operate three threshing rigs.

ters and sweethearts, swayed alternately by hope and despair, who are eagerly seeking information about the soldiers so close to their hearts.

To ease their sufferings, the American Red Cross has undertaken a search for the missing. Its searchlight, thrown on overseas battle fields, base hospitals, and embarkation camps, has probed the mystery of many a boy's silence and brought news of his whereabouts or death to the anxious family at home.

"Please send me news of my boy," begged the mother of one private. "I only know he has been missing since July 15. It is worse to be in doubt than to know he is killed." The young man's name and his regiment were immediately filed, and sent abroad to be added to the searcher's list that is published monthly by the Red Cross.

Searchers travel through the base

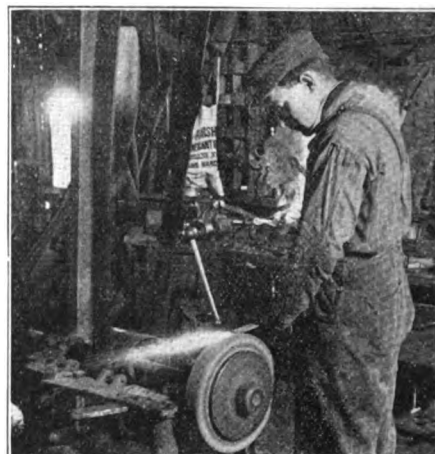

THE POWER DRIVEN EMERY GRINDER IS A PIECE OF EQUIPMENT NO SHOP CAN AFFORD TO BE WITHOUT

TUBE VITAL TO TIRE LIFE

As "the chain is no stronger than its weakest link" so a tire is no stronger than its inner tube.

There are a great many owners of cars who do not take due heed to this simple truth, and the result is poor service from some of the best casings.

In the making of inner tubes, three things must be considered. First, the rubber must not have pinholes. Second, it must be of a composition which will not allow the escape of air through chemical action. Third, it must be able to stretch and flex without excessive overheating.

To build a cheap tire is a comparatively easy matter. Such a tube may have a nice appearance and an apparent tensile strength, but at the same time may have a propensity for leaking air by diffusion or chemical assimilation that renders it inefficient and impractical as an

air container for the inside of a casing.

THE PORT OF MISSING MEN

Though the war with its awful holocaust of human life is ended, and the world hopefully resumes the arts of peace, the casualty lists with the long roster of the missing are still breaking the hearts of thousands, and mothers, wives, sis-

and military hospitals, through rest camps and embarkation camps, carrying with them their books of missing men. Everywhere they go they get into communication with patients and other soldiers stationed at the same command as the

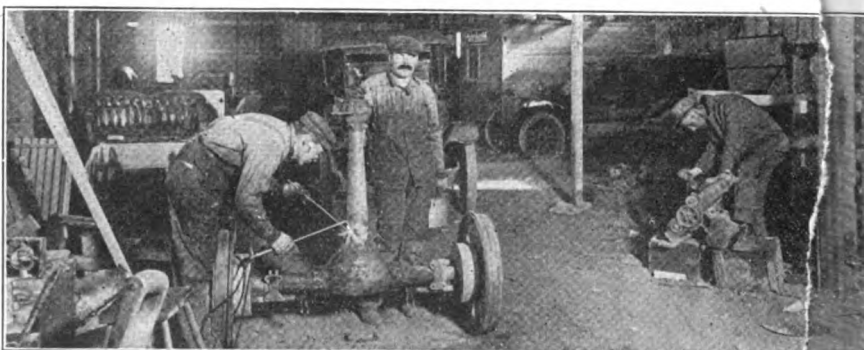

A CORNER OF THE AUTO REPAIR SHOP OF THE VARIETY MACHINE SHOP



WELDING A DYNAMO OUTER END BEARING AND END SHIELD THAT WAS BROKEN IN THREE PARTS. THE BEARING IS COVERED WITH ASBESTOS TO PREVENT MELTING THE BABBITT

missing men. In a recent case, a young lieutenant was found in De-barkation Hospital No. 3 who knew one of the missing men and had seen him die. His story as written into the record was that Private Sand, the missing soldier, had been killed on July 15th at the battle of the Marne, while saving the lieutenant's life. The news was immediately wired the bereaved mother. She is now waiting to meet the lieutenant for whom her son went to his death and to learn from him the details of the tragedy. And the lieutenant will make this trip to see the boy's mother even before he goes home to his own family.

DON'T FORGET — SEND THIS MAGAZINE "OVERSEAS"

The boys overseas are asking for more reading matter. General Pershing has cabled the request that more magazines be sent to the Americans on duty in France and in other countries in Europe. The General says the boys need interesting reading matter as never before.

The supply of magazines has been reduced from ten to two tons a month due to misapprehension of the public that magazines could not be sent under the one-cent postage ruling. Some magazines inadvertently dropped the line announcing that publications would be carried overseas under a one-cent stamp. The ruling is still in force and magazines are being asked to print

it again in the upper right-hand corner of their first page.

Red Cross divisions and chapters are urged to stimulate renewed interest in the sending of magazines abroad by acquainting the public with the fact that the one-cent privilege still exists; also to dwell upon the statement of General Pershing that American Expeditionary Forces, with the excitement of fighting campaigns gone, are greatly in need of interesting reading while waiting for the day when they will receive word they are to be sent home.

In order that the shortage may be quickly overcome individuals are asked to double and triple the number of magazines they previously were accustomed to send.

TO STRAIGHTEN AUTO RIMS

Make a chalk compass with a piece of string and a stick of common crayon, and describe a circle on the floor the same diameter as inside of rim. In most cases the diameter is 26 inches. Then take the rim on an anvil, and by striking it with a heavy hammer over end of anvil and over shoulder you can either expand or contract the circle. Now and then fit it to your pattern on the floor, and when rim is perfectly round you should be able to see the inner half of your chalk mark clear around the rim on the inside.

To find proper hole to put lug rim in: Some auto rims have a lug on inner side and this lug is placed within three inches of the valve

NO. 1 ANY WAY YOU TAKE IT



Auto license authorities have their troubles every year with people who want certain numbers and with other people who don't want certain other numbers.

The Indiana state authorities gave Mr. G. A. Sieberling, general manager of the Haynes factory, license No. 1 this year, and the picture shows the whole combination. Speed cops won't have to use their brains any more than they ordinarily do to remember this number.

stem hole. When this lug is broken or pulled out it is sometimes hard to determine which hole the lug goes in, as they are exactly the same size. My way of telling is to place hinge or clamp at bottom as rim stands on edge, and place lug in the righthand hole.

Microscopical air leaks in inner tubes are often difficult to locate, but at a higher pressure the leak will be very much more noticeable. A tube will only stand a few pounds of air pressure before it begins to bulge ominously and warns that the bursting point is near. If, however, the same tube be wrapped with cord, the loops being from 2 to 3 in. apart, it will stand a much higher pressure. It only takes a moment to make the necessary wrapping, and with this support and use of greater pressure it is possible to detect small leaks.

THE NAVY USES TRACTORS TOO



Tractors of the tank tread type hauling the NC-1 from the water just after its last test flight before starting on the first section of its trans-Atlantic flight. Many of the naval air stations have been equipped with the make of tractor shown and which serve a variety of purposes faithfully and well.

Some Information Regarding Chisels

J. N. Bagley

ONE day not long ago the writer happened to be in a work shop where one of the mechanics happened to be doing a job that necessitated the use of a chisel to remove quite a little surplus metal from a steel bar. He placed the bar in the vise and began looking about for a chisel to do the job. The first one he picked up was a small one made from $\frac{3}{8}$ " octagon stock about 6" long. He then look-

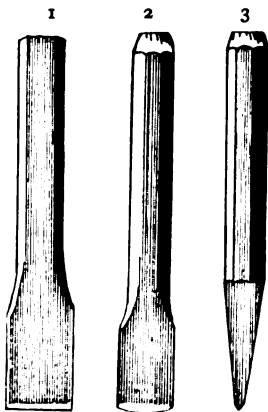

FIGURE 1

ed for a hammer and after moving a conglomeration of tools from the bench he succeeded in finding a hammer that weighed about two pounds. With that $6 \times \frac{3}{8}$ chisel and the two pound hammer the "mechanic" went over to the vise where the bar was placed a few minutes previously. He struck a couple of blows and the chisel bent about two inches above the cutting edge. The mechanic, (anyhow we will call him a mechanic for luck) spat under the bench and remarked "Of all the d— chisels, they have them around this place," and he began to hunt for another chisel. After searching for about half an hour he found a chisel made from $\frac{1}{2}$ " stock and about what he thought he wanted, but during the hunt for the chisel some one got his hammer. He finally resurrected a small eight ounce ball pein hammer and started to work. The hammer was small and again he blamed the chisel and again he began to hunt for some more chisels. This "mechanic" was still swearing and hunting when I left, nearly an hour later.

Someone was paying for this man's time; someone was buying

the tools he was breaking up. A cold chisel is a valuable tool and deserves just as much consideration as does the taps and dies, or the drill bits, etc., found in the repair shop.

Every work shop, no matter how small, or how large, uses the chisel. Many prefer to buy their chisels rather than to make them, but even so, the repair man should be able to make special chisels for special jobs, and also be able to work over the old chisels as they break down, which sooner or later they will do. Quite often a chisel will break down when it is properly made, when being subjected to some class of work it was not intended for, for instance—a chisel made from $\frac{5}{16}$ " stock would not stand up under the blow of a two or three-pound hammer — neither will a chisel stand driving where a wedge should be used, therefore, it behooves the mechanic using the chisels, to use judgment in selecting the chisels for the particular job; the hammer to use as to weight and the material on which the chisel is to be used.

SIZES AND SHAPES OF CHISELS

At this time a few hints on making chisels of different sizes for different purposes will no doubt be of value to some reader. The first thing to do will be to secure the stock of which to make the chisel. This stock may be round, octagon, hexagon, or steel having two broad flats, diametrically opposite. The latter forms a guide to the eye in holding the chisel to the grinding wheel when grinding the facets

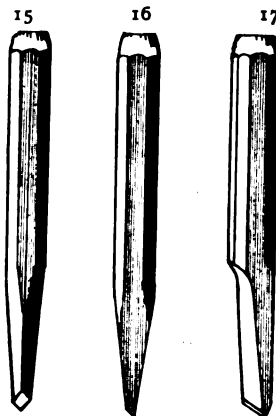

FIGURE 4

that form the cutting edge. This style of chisel is shown in Fig. 1 at No. 1. No. 2 shows a chisel similar except a rounded cutting edge and being made from hexagon steel. No. 3 same as No. 2 except showing the chisel in the reverse position. Chisels of this type are made from stock ranging from $\frac{3}{16}$ " in diameter to one inch, or even larger,

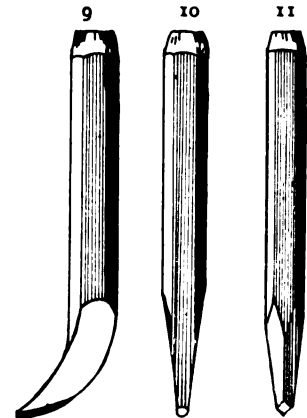

FIGURE 2

but for the repair shop $\frac{1}{4}$ to $\frac{3}{4}$ are the sizes most used. The diamond Point chisel shown in Fig. 2, No. 15, and No. 16, can be made a number of ways, that is, for holes of different depths. In shallow holes it can be leaned over, whereas in holes that are deep they must be held straight. This type of chisel is valuable in roughing out slots and key ways, to be finished with a type of chisel as shown in Fig. 2 No. 17. The stock from which this chisel is made must be selected with the work in mind, for which it is to be used. If the job is cutting a heavy key way in a four inch shaft the chisel should be much heavier than if the key way was to be cut in a $\frac{3}{4}$ " shaft.

The round nose chisel shown in Fig. 3, No. 6, should be made straight from the widest point to within $\frac{1}{4}$ inch of the cutting edge, so as to permit the chisel being raised or lowered to govern the depth of the cut. In case this is made with either a flat cutting edge or a round cutting edge, the nose should be wider than the metal higher up, so that the chisel head may be moved sidewise to govern the direction of the cut. No. 7 shows a straight cut edge, while No. 8 shows a round cutting edge. In Fig. 4 we have shown at No. 9 and No. 10, chisels used for cutting oil grooves. These are used usually in a soft metal such as babitt or bronze, therefore, a thinner edge can be ground than if the



Besides men and munitions and money Uncle Sam sent thousands of tractors to Europe so that strain on our granaries wouldn't be so great. When the all around versatility of the tractor became as well known in Europe as it is in this country, the call for tractors for all sorts of purposes increased and this picture is a "Case" in point where the tractor was called upon to save time and manpower around French aerodromes when both were so urgently needed elsewhere.

chisel was to be used for cast iron or steel. This type of chisel should be wider at the cutting edge to prevent leaving a feathered, ragged edge on the oil groove. No. 11 can be used in some instances for oil channels in a straight cut with the point shown, or it can be rounded, cutting an oil groove quite similar to the one cut with chisel No. 9. The No. 11 would not work well on a curved surface unless the oil groove was cut on the outer periphery of a bearing. No. 9 should be so shaped that it nearly fits the periphery of the bearing or it will be a difficult matter to keep the chisel dipping or gouging when cutting the oil channel. One should have a number of oil channel chisels made up, ready for use; different thicknesses and shapes,



FIGURE 5

from stock of 3/16 to 3/8 or even 1/2 inch, depending on the class of work handled in the shop. Many times it is advisable to use this type of chisel about twice the length of the ordinary chisel.

No. 12 in Fig 5 is a chisel known as a cow mouth chisel. This type

of chisel is very useful when made up in different sizes. No. 13 and No. 14 are used for special jobs that come up from time to time and are a good pattern to add to the chisel stock.

Fig. 6 shows the manner of holding the chisel to obtain good results. The facets forming the cutting edge should be straight in their widths, as shown at No. 4 in Fig. 6. The face next the work should form a guide in holding the chisel at the proper angle to maintain the depth of the cut. Of course this angle depends to a great extent upon the nature of the material to be cut; the facets forming an angle one to the other of nearly sixty-five degrees, for cast steel, and forty-five to fifty degrees for bronze or brass. Therefore, the more acute these angles the nearer the body of the chisel lies parallel with the work. The hammer blows will be far more effective with the angles of the chisel correctly ground. The angles should always be made as acute as the hardness of the material will permit. In case the angle was too acute the chisel would be very apt to be bent near the cutting edge and if to the reverse the cut would not be deep enough. Hence the object is to make them as acute as possible without causing the cutting edge to bend in its length. Now in case the metals to be cut are soft, such as copper or babbitt, the angles may be about thirty-five degrees. Care should be taken that the chisel does not wedge or it will either bend or break.

The chisel should be held as close to the head as possible, so the hand will steady the head, as the blow of the hammer falls on the head of the chisel the hand holding the chisel

should be pushed forward firmly, which will in every instance greatly facilitate rapid, smooth cutting of the chisel. In case the chisel is being used on copper or wrought iron, a very good plan is to dip the



FIGURE 3

chisel into water as it makes cutting or chipping much more even with less effort.

Hardening and Tempering the Chisel

Hardening and tempering processes are performed upon cold chisels for three purposes: in the first place to enable it to resist wear; second, to increase the elasticity of the steel and third, to enable it to cut substances harder than the chisel itself.

The first operation of hardening the steel is not of such vital importance as drawing the temper. The second process will be found more difficult, inasmuch as the quality of the steel may vary in carbon points. For the ordinary cold chisel steel with 1 percent carbon makes a very good chisel but in

Continued on Page 226

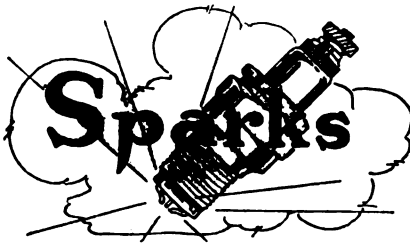

Really prices should come down once in a while to see the country they were raised in.

When a fellow tries to find out from her mother if a girl snores she may be pretty sure his intentions are serious.

Also, the man who rode the first "safety bicycle" in this country—what's become of him?

Ambition never grows old. In fact it doesn't always reach maturity.

Ah! the proof-reader still yawns! Perhaps the new King of Siam, Chowfa Maha Vijravuch, will stimulate him.

The last day of June is Monday but every day will be Sunday, bye and bye.

Even age has its compensations. After a girl passes 30 we won't have to buy any birthday presents for her.

It makes a young man happy to have a girl return his love—unless she has no use for it.

A fat girl is always good-natured. Try to sit on an angular one and you'll find her too sharp for you.

It is mighty easy to impose on a friend the first time. But you'll find it mighty hard to impose on him the second time.

It isn't nice to interrupt a person in the midst of a sentence, but any sentenced prisoner may get something off for good behavior.

Fifty dollars' worth of clothes will transform a girl who is long and lanky into a girl who is tall and graceful.

The father of the family of old maid daughters sized up his flock despairingly. "It is true that many have called but few have chosen," he paraphrased sadly.

We'll bet there will be some weird and wonderful prohibition booze made at home about two years from now. But it is all in getting used to it. We once met a Siwash squaw who made herself what she called whisky by soaking a plug of tobacco in an old tomato can filled with water and adding a little cayenne pepper to the mixture. And when we gave her a drink of good Scotch whisky she spat it out in disgust and informed us that it tasted like it had lye in it.

And when the hostess is boasting about her hand painted china she never says a word about her hand painted complexion.

In standing up for yourself do it gracefully. Don't tread on other peoples' toes.

You may have noticed that it takes something that is none of his business to work up a man's curiosity. And this goes for the women folks too.

By the time a man is old enough to know better he is too old to take advantage of his knowledge.

Maybe we are wrong but if we were a woman we don't think we could ever love a man well enough to support him.

Don't get the reputation of being a do-nothing. Some people who have nothing to do but mind their own business won't even do that.

Many a reputation has been blasted without the use of high explosives.

A man's idea of a hopeless mutt is a man who can't beat his own wife playing cards.

OUR HEROES

When Colonel Weathersbee returned from serving over there

You might have thought that he had earned a golden Croix de Guerre.

A banquet every other night to fix the colonel's fame—

He had no part in any fight, but he was not to blame;

His job was purchasing the hay on which the mules were fed,

And thus he helped in his own way to fill the Hun with dread.

How proud we were to listen while he told his thrilling story:

He did it in heroic style and crowned himself with glory.

When Private Greene came back he brought

A sleeve he didn't use;

And no alert reporters sought

Him out for interviews:

No banquet was arranged for Greene;

They let him go his way.

For who cares what he may have seen

Or what he has to say?

When Major Arbuthnot came home we cheered him, old and young;

The local paper had a "pome" in which his praise was sung;

We hung up all the flags in town and packed the biggest hall

To hear how he had won renown and caused the Kaiser's fall.

The major had a major part in helping Pershing through;

He bought the tinware from the start, and sorted letters too;

A tower of strength indeed he was; among the heroes list him;

We gave him thunderous applause and thirty ladies kissed him.

Last week when Sergeant Tommy Glenn Came limping back from France

He got a handshake now and then—

Perhaps a friendly glance;

But that was all! Who cares a rap

What he did overseas?

He wears no eagle on his cap,

And his are cloth puttees.

—S. E. Kiser in Saturday Evening Post.

Some people get no credit for their good intentions and others are able to convert their into cash.

Once in a while you run into a bright fellow who is almost as intelligent as you are.

Even the baseball player can see the error of his way when he reads the box score in the newspaper.

What has become of the old-fashioned schoolboy whose school-books were covered with calico by his mother?

A magician may turn water into wine, but it takes an amendment to the Constitution to turn wine into water.

The trouble with having callers is that so many people don't know the difference between hospitality and endurance.

Lots of golden opportunities are merely glittering generalities.

Another good bet is the fact that when your wife is wrong she is going to be the last one to find it out.

Would you say that a man with an ax to grind was looking for somebody to do him a sharp turn.

At the present price of pork it is necessary to cast your pearls before swine.

Even a clock can take a rest when it is all run down in the spring.

You never can tell. Even the prohibitionists may be drunk with power.

Nearly time to can the booze songs, but "The Old Oaken Bucket" is left to us still.

A new broom sweeps clean, but as a rule a new servant girl is a different proposition.

THE FREEDOM OF THE PRESS

UNDESIRABLE CITIZENS

Dairyville has three new tanks.—Westhover, S. Dak., Banner.

THEY'RE A STUBBORN SEX ANYWAY

Deputy Medical Examiner Stocker tried to get a post-mortem statement from the woman yesterday, but she refused to give one.—A local Contemporary.

HERE'S A CHOIR LOFT YOU'VE MISSED

Because of the shortness and tightness of the skirts worn by the young women of today and the display of hosiery in the choir loft, I move that a 20-inch curtain be hung from a brass rod around the choir loft.—Mrs. George F. Reinking's resolution in the Des Moines Avenue Baptist Church.

CHANGING THE PILLOW CASE

PILLOW VS. PILLOW—Change of venue, Montgomery county to Adrian county, September term.—Madison Record.

AND TANK IS MORE THAN ¾ RIGHT

Tank Beverly is against the custom of giving three cheers. Tank says that in most instances one cheer is enough.—Topeka Capital.

IT MUST BE!

It must be discouraging to sensible vaudeville artists at the Dominion theater in Winnipeg to have to step out and do their stunts in front of an advertising curtain whose centered, isolated and most prominent legend is "Premier Hams."—Winnipeg Eye Opener.

CULTURE IN BLANCHARDVILLE

Mrs. I. C. Boot arrived this A. M. from Blanchardville, where she has been the last two weeks giving a sewing machine recital.—Monroe, Wis., Sentinel.

O THESE TYPES!

A son weighing 111 pounds was born to Mr. and Mrs. Fred Scallon Sunday night.—Mercyville, Ia., Banner.

MORE HARMONY IN THE CHEERS, PLEASE

Roy Riker's son has become a cheer leader in college, but Roy, who furnishes the funds, isn't as cheerful as he might be.—Lapeer, Mich., Press.

TIME TO CHANGE

For the last ten days Fred Lucas has been wearing a fancy blue shirt which makes him look very sporty.—Brayer, (Mo.) Comet.

YOU'VE CERTAINLY GOT TO HAND IT TO JONES FOR PEP!

If every man in Bangor has accomplished as much as I have since the big fire three years ago you would have some Bangor. I have added to real estate for Bangor \$35,000 in new buildings. I have just added a daughter worth \$100,000 more; you old fellows want to brace up.

Patronize home industries. If you smoke, buy cigars made in Bangor. It all helps, I am keeping 14 men, four girls and nine horses busy at my store; two doctors and two nurses at the Paine Hospital. What more can one man do to help a town?

JONES OF BANGOR.

—Ad in Bangor Exchange.

COVERING CAPACITY OF PAINT

To determine the quantity of paint required to cover a given area, measure the length and width of the building and obtain the perimeter or number of feet around the building. Multiply this by the average height and the product will be the number of square feet to be painted.

A good paint should cover 300 square feet of surface, two coats, per gallon of paint. Divide the number of square feet to be painted by 300, and the result will be the number of gallons that will be necessary to cover the ordinary surface. A very porous, rough or scaly surface will naturally take up more paint. If three-coat work is desired, half again as much paint will be needed.

ON THE JOB TOO SOON?

The latitude allowed the Federal Board for Vocational Education in the administration of the Vocational Rehabilitation Act, is as broad in some of its phases as the restrictions are limited, in others. The law only allows those men to participate in its benefits who are "compensable," and whose disability is as least 10 per cent. But the disabled man is allowed much liberty in his decision in regard to undertaking the training courses. It has been the natural impulse of these returned soldiers to get back to work as quickly as possible. Many, seeing no benefit in wasting time at some training school, have taken the first job offered, and

often in a short while have been forced to give it up, realizing that their strength was not sufficient to "carry on." This experience, though unfortunate, need not be discouraging. The offer of the government is still open to such men, and many are finding it to their advantage to come back and get the preparation which they need. The Board is particularly anxious to have the assistance of the public in making this opportunity known to all disabled men who, having reentered civil life, are finding their handicaps too much for them. They have demonstrated the need for this special training—it may still be theirs for the asking.

REPAIRING CAST IRON

A safe rule for this class of work is to always put a patch of wrought iron on, that is as heavy or heavier than the original piece of the broken part. If you take extreme care to have your patch lying flat at all points a very few rivets will answer the purpose. The size of the rivets should always be judged by the thickness of the original cast iron, and a safe rule to follow is to make the diameter of rivet hole the same as the thickness of the iron. For instance, a broken piece of cast iron one-fourth-inch thick should be riveted with one-fourth-inch rivets. Of course, the larger heavier piece such as three-fourths-inch and up need not bear such heavy rivets; one-half-inch rivets will take care of a 2-inch piece of cast iron O. K.

Benton's Recipes

Modeling Compound—Knead dry clay with glycerine instead of water, work thoroughly with the hands, moisten work at intervals of two or three days and keep covered to prevent evaporation of moisture.

Truing an Oilstone—Use a piece of soft pine board about eight inches wide by three or four feet long. Lay it on the bench and plane the face dead smooth. Drive nails at ends to hold in position. Sprinkle the board with some clean, sharp sand, screened as fine as that used for plastering. Use no water but rub the stone back and forth on the sand. This will smooth the face of stone very quickly giving a flat, well finished surface. Keep the rubbing motion lengthwise.

To Produce Brown Finish on Steel—To produce the rich brown finish that is commonly used on guns use sulphate of copper, 1 ounce; sweet spirits nitre, 1 ounce; distilled water, 1 pint.

Four coats are applied, allow several hours to elapse between the successive coats, brushing after each if necessary. After the last coat, rub down hard and allow to dry 24 hours. This gives a reddish-brown color without gloss. By adding arsenic to the mixture before last coat a deeper hue is obtained. The polish is obtained by means of a mixture of boiled oil, beeswax, and turpentine, comparatively thick. Rub in well with cotton cloth and finally with the palm of the hand.

To Blue Gun Barrels—To blue gun barrels and other pieces dissolve 2 parts of crystallized chloride of iron; 2 parts solid chloride of antimony; 1 part gallic acid in 4 or 5 parts of water; apply with a small sponge, and let dry in the air. Repeat this two or three times, then wash with water, and dry. Rub with boiled linseed oil to deepen the shade. Repeat this until satisfied with the result.

Ebonizing Wood Handles, Etc.—To prepare a mixture for ebonizing wood handles, etc., use logwood, 2 ounces; tannic acid, 1 ounce, and sulphate of iron, 1 ounce. Apply hot and polish when the pieces have become dry and cold.

Fire Clay Mixture—A fire clay mixture that will stand a high temperature without cracking or checking is mixed as follows: 45 per cent crushed fire brick, 50 per cent fire clay, and 5 per cent clean, sharp sand. This is to be moistened and mixed to a heavy paste, tamped into shape required and burned dry.

To Case-Harden for Colors—Mix 10 parts charred bone, 6 parts wood charcoal, 4 parts charred leather and 1 part of powdered cyanide potassium. Clean the work thoroughly, and do not handle with greasy hands. Pack the work with the mixture in a common gas pipe plugged at one end, and seal at the other with asbestos cement. Heat in a furnace to a dark cherry red and keep at that heat for about 4 or 5 hours. Dump in a tank with compressed air bubbling up through the bottom. If the colors are too gaudy leave out the cyanide.

Cement for Iron and Marble—For fastening iron to marble or stone a good cement is made as follows: 30 parts plaster paris, 10 parts iron fillings, 1/2 part sal ammoniac mixed with vinegar to a fluid paste fresh for use.

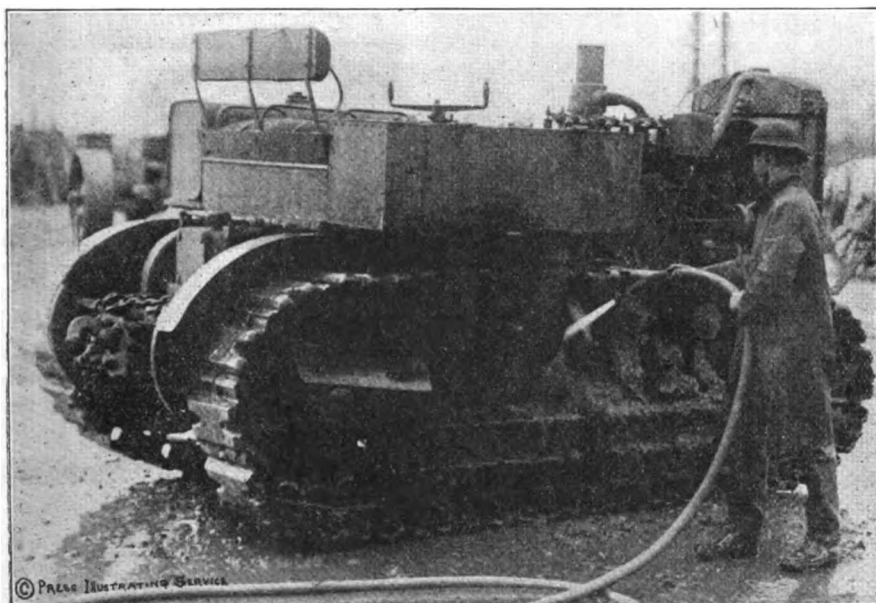

"WASHING DOWN" A 10 TON ARTILLERY TRACTOR AT THE GOVERNMENT'S ABERDEEN, MD., ARTILLERY PROVING GROUNDS

APPLYING CONNECTING ROD BUSHINGS

The bushing is started into the connecting rod and then it is placed in the vise and the jaws tightened

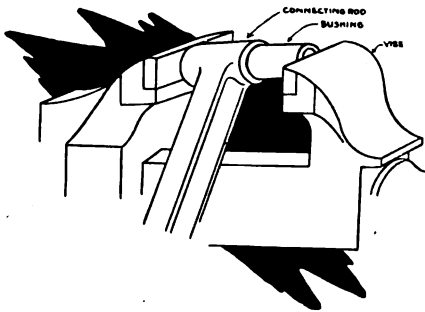

up, forcing the bushing into position. Care should be taken to see that the bushing is started evenly.

NON SPILLING FUNNEL

Here is an odd but no less useful kink that originated with the writer after overfilling the funnel several times when filling narrow necked containers. Nine out of ten people, when filling anything with a funnel will pour in more than the container will hold and then quickly lift it out and try to place their finger over the spout to save the excess oil or liquid in the funnel.

The funnel with the attachment shown eliminates such trouble. A

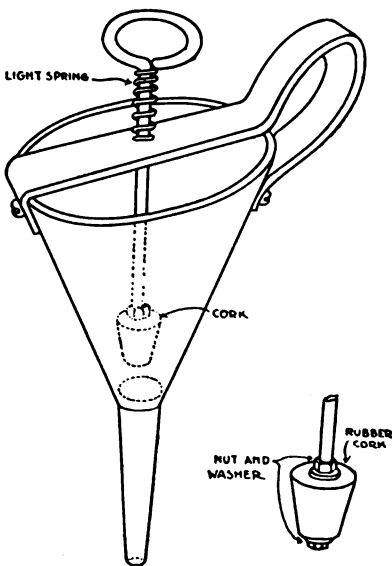

bit of thin strap or band iron is used for a combined handle and bridge piece, as at A, a small rod threaded at the lower end and on it a rubber cork is placed held by nuts and washers, as shown at B. This rod is passed through a hole in the bridge piece, as shown at B and held up lightly by a small spring. Now when using this funnel if you pour in too much it can

be saved when lifting out the funnel just by pushing the rod and cork down into the neck of the spout.

VALVE SEATING TOOL

Having need of extra valve re-seating tools for use in our busy shop, I proceeded to design and make them right in the shop. They proved so efficient and handy that I have since made them for truck owners. They are very simple in construction and even a novice could, (after being shown how on one valve seat) reseat all valve seats.

I have sketched the tool and shown its application, Fig. 1, and from it any reader can get the details so that he may construct them for his use. The upper part of the tool (A) is of 1 1/8-in. round stock, the lower end of which has a square hole in it for the cutter (B). This cutter is secured by the threaded end of the guide rod C, which rod is the same diameter as the engine valve stems. The tool is self feeding, all pressure for this being regulated by the tension of the spring

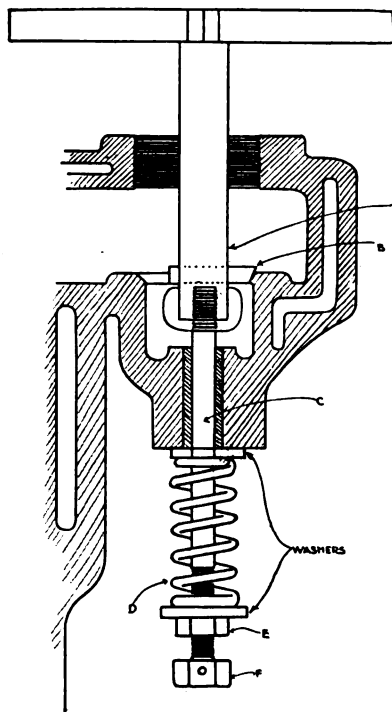

D (the regular valve spring can be used for this). The adjustment of the spring tension is provided for by the nut E. The tool is assembled for use as follows. The upper section A, with the cutter B and rod C are assembled and the cutter adjusted for width. This much of the tool is then slipped into place and the top washer spring, bottom

The Kink and S

Char

washer, adjusting nut, and bottom securing nut put on at the tool is placed in position. The bottom nut has a pin put through it to hold it so that when tightening the rod against the cutter it will not turn.

TOOL TRAY FOR CREEPER

Tool trays fitted to the creeper save a lot of time and irritation looking for tools and feeling around over the dirty floor for

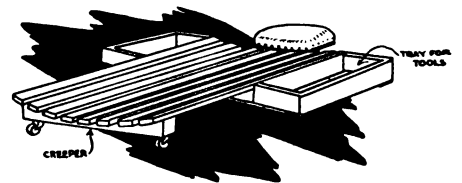

them, usually finding them underneath the creeper or getting tangled up in the casters. The trays keep the tools where you can get them.

WRENCH FOR POLISHED PIPE

This is a real practical tool made from a special shaped hickory stick, some bolts, nuts, washers, and a bit of heavy canvas or length of leather belt. It is a pipe or tube wrench that grips the surface of the pipe as well as the regular pipe

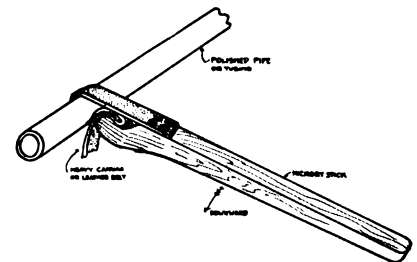

Stillson wrench, but does not scratch or mar the finish of the pipe. It should be easy for anyone to make one from the sketch and no measurements are given, for it must be made to suit ones needs in size. The whole secret is in the curved end and looping of the strap, shown at A.

EASY TO MAKE ADJUSTABLE CLAMP

This sort of a clamp answers the need of several different size clamps and is very simple to construct. Those smiths who do any amount of wagon, truck, or body work will appreciate having a pair of them in

Note Corner

green

the shop equipment. A very fair size to make is $\frac{3}{4} \times 1 \frac{1}{4} \times 24$ inches, as indicated in the sketch. The double headed wedge key or gib is the means used to secure the sliding jaw at any position on the bar jaw can be reversed to enable its desired. It provides a positive non-slip grip. The grip is shown in detail in the sketch A. This type of clamp has the distinct advantage over others in that its sliding

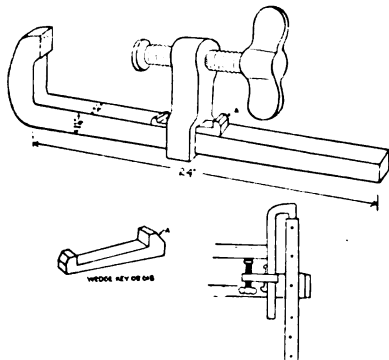

being used on other sorts of work such as shown on the wagon job in the small sketch.

FLEXIBLE SHAFT

Occasionally means are needed to drive two shafts that are slightly out of line, such as a magneto shaft, etc. For light work and

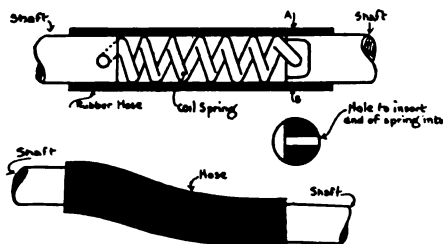

where it is impossible or undesirable to use a universal joint a flexible joint can be made from a piece of coil spring, fitted to the shaft as in the illustration and covered with a piece of rubber tubing.

A new tractor just off the car is never the best one for demonstrations.

It is always best to use one for demonstrating purposes that has been driven at least ten hours.

A tractor that has been worked in will deliver from fifty to eighty per cent. more power than a brand new one.

KEEPING THE BEARINGS COOL

For keeping the babbit bearings of engines and other large bearing surfaces cool, small copper tubes are bent and cast into the bearing

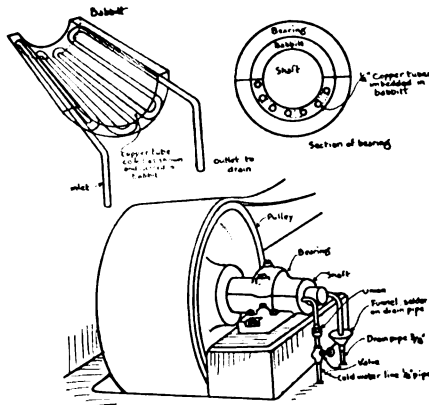

as shown and connected to a water line. These water pipes should be cast at a good depth in the bearing metal so that they will not be too close to the surface of the bearing.

GAS HOSE RACK

The other day I stopped for some gas at a roadside station and picked up an idea that seems worth describing. A section of an old tire rim was made to serve as a hose rack over the gasoline stand for the gas hose, as shown in the

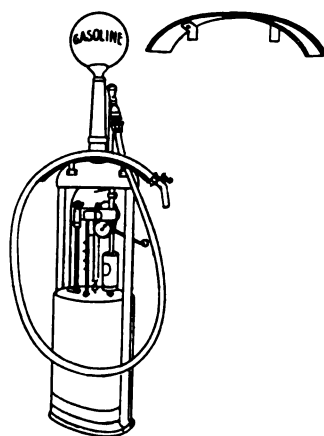

sketches. The generous circumference of the rim made it an ideal rack for the hose to rest on, preventing kinks or short bends in it and thus preserving the life of the hose. The same idea may be applied to the garage air hose, using a couple of sections to make this rack.

VALVE GRINDER

This unique valve grinder is perhaps one of the cheapest and handiest tools for the work yet de-

vised; it consists of a bit of stout cord, an old coil spring, a valve tool made of a bit of hard wood, and two special bent feet made of wire spikes. These are shown in the small detail sketch. The large sketch shows how the tool is used. One end of the spring is secured over the nearest cylinder head stud. A stout cord is given a couple of turns around the round wooden valve tool, and one end tied to the spring; the other end is secured to a triangle grip made of small rod. By pulling on the cord the valve is revolved a few turns, then by holding lightly on the cord, the spring will revolve the tool back again,

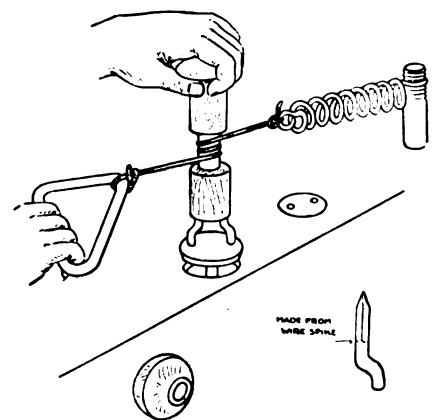

thus giving the correct back and forth motion to the valve during the grinding.

To make the tool more effective the top if it can be made like the handle of a bit brace, that is a knob or loose grip such as shown at A makes it easier to guide the tool when revolving it.

VALVE GRINDING HINT

A Hartford, Conn., repairman saves time when he grinds in valves. He removes the valves from the engine and places them in the chuck of an electric hand drill which he secures in a benchvise. With an old file he removes the carbon from the under side of the valve and uses emery paper on the head. He polishes the stems in a like manner and files off the burrs on the bevels. He asserts that he bears on the work so lightly there is no danger of bending the stem or unnecessarily reducing the metal. With the valves all bright and clean the final grinding process takes very little time. The repairman has followed this practice for some time and says it is eminently satisfactory.



Balancing THE Overhead

Robert Falconer

A business man acquired a fortune in the city. He purchased a farm, equipped it with all the modern conveniences he knew about or learned about and moved to the country to enjoy the rest of his days. For the first few years his income from other investments met the deficit on the farm. When this became inadequate debts accumulated and the farm was finally sold to pay the taxes. The business man then returned to the city to make another fortune. What was the cause of the failure?

Too much overhead.

A farmer, having accumulated a considerable sum of money, comes to the city and buys a store. He fills it with all sorts and types of labor saving devices. He rents large storage space and additional sales floors. Each year he runs behind. Finally the sheriff comes around and sells him out. Why did he fail?

Too much overhead.

A miser is forced to take over a business owned by one of his creditors. He saves on every hand. He lights his store only when customers enter. He keeps his money in a cigar box. His counters are boxes with boards laid across them. Everything is as cheap as possible. He hires boys to help him. He considers men too expensive. Not enough business is done to pay expenses and the miser loses the money he was forced to invest in the store. What made him fail?

Too little overhead.

The overhead must be balanced—The feats of balancing we see at the circus are not nearly as difficult as the feat every business man must

perform in balancing his overhead. Just as the man at the circus must exercise great skill, for a false move in any direction will upset the balance, so the business man must exercise great skill in keeping his overhead exactly the right size. Too much or too little will reduce profits.

Too much overhead smothers the business. Too little overhead chokes it to death. Too much overhead eats up all the profits. Too little overhead undermines the business. It is extremely dangerous to let the overhead swing too far in either direction. It must be balanced. It must be made to fit the business. Only when it exactly fits the business can the greatest business progress be made. Only when it exactly fits the business can the business man be truly successful.

Too great an overhead fatal—Too great an overhead is usually fatal. It requires more than the profits of the business to maintain it. The overhead eats into the capital. Eventually, unless cut down or the business made to grow to fit the overhead expense, it

drives the business into bankruptcy. All fixed charges must be held down to a point where the profits will more than cover them if the business is to be successful.

The overhead presents to the business man one of his most difficult problems. Every man with any ambition at all desires to have his business grow. To grow, there must be a reasonable overhead. There must be labor saving machinery, there must be equipment for rendering good service to the customers, there must be floor space enough to permit expansion. If these things become too expensive, however, the profits do not cover them and the business fails.

Too low an overhead cuts down profits—Too little overhead may prove just as serious as too much. For a given overhead profits cannot exceed a certain amount. This amount will vary in different lines of business and in different localities but it is always fixed. The service rendered by competitors strictly limits profits to a fixed sum. To have profits exceed this sum the overhead must be increased. If in-

ANOTHER OF OUR NATIONAL PASTIMES—TRYING TO MAKE THE FLIVVER LOOK LIKE WHAT IT AIN'T

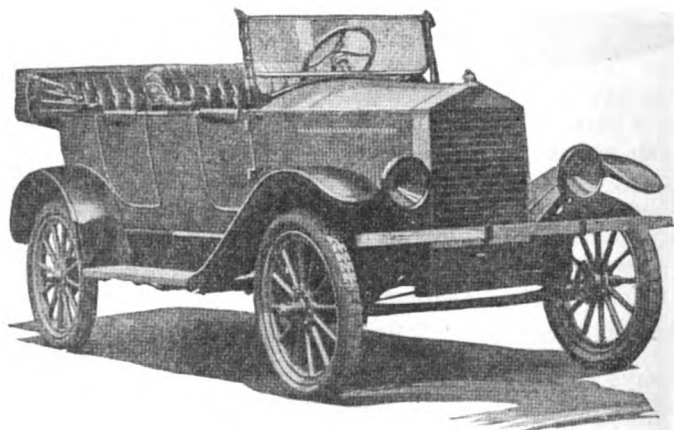

There isn't enough camouflage in the world to conceal the identifying characteristics of the Ford car although the illustration shows a manufacturer's ambitious attempt to graft a "Rolls-Royce" type hood and a miscellaneous assortment of sheet metal work
To Fords

stead of increasing, it, the overhead is reduced the profits fall off. Continued reduction will continue to reduce profits even down to the zero point where the man is forced out of business.

Balancing the overhead is something that each man must do for himself. You can't tell a man how to place a ball on the top end of a pole and balance the whole on the end of his nose. Such a stunt requires practice. It can't be learned from books or correspondence schools. The only way one can accomplish the feat is through constant practice. The same rule applies to the balancing of overhead.

Balancing the overhead requires practice—It is exactly the same with the overhead as it is with the balancing stunt in the circus. The business man must practice. He must watch the results of each movement just as the circus balancer does. He must practice and watch until he has the overhead just where it will produce the greatest profits. He can't stop there, however. After the circus balancer has everything nicely arranged a slight movement of some other person or a faint breeze may upset the whole balance. He must constantly watch and adjust the balance or the act is a failure.

Once having balanced the overhead the business man may find that a slight change in business conditions or some act of a competitor may change things just enough to make it necessary to readjust the balance of the overhead. As his business grows the overhead must be increased. Careful and constant watching is necessary.

Everything must exactly fit the business—To keep the overhead properly balanced everything in the business must exactly fit. A \$10,000 man must not be holding a \$1,200 position. A cash register designed for a hundred thousand dollar store must not be used in a ten thousand dollar store. Each machine and each individual must fit the business exactly. Nothing must be too small or too large. Sufficient sales and storage floor space must be provided to give adequate service but not an inch more. Fixtures and other equipment must be provided that will adequately meet the demands of the business but no more. Labor saving machinery that will really save labor must be used to the extent that it cuts down operating and fixed expenses but

"WE ALWAYS DO ALL WE AGREE TO DO, AND THEN SOME. IT'S THE 'THEN SOME' THAT BRINGS THEM BACK AGAIN."—FRED CORRELL



There's nothing particularly impressive about this shop and store as a piece of architecture but Fred's motto above shows one reason why it is one of the best known establishments in rural Illinois—the other reason is Fred himself

not a dollar more than is necessary must be invested in this equipment.

Every penny spent must increase the profits or make the business grow. If possible every penny must do both. Not a dollar can be invested in idle overhead, in overhead that is not needed, that is not making the business more prosperous, if the overhead is to be perfectly balanced.

SPLICING SAND BELTS

In cases in cutting and splicing sand belts some mechanics simply thin down the ends and make a short lap. This may do for some work if the lap is run in the right direction so that the work will not tear it apart, says an exchange. It is advisable to butt joint the ends and hold the belt together with a short length of thin cloth on the back. Some use square butt joints; some cut the joint at 45 degrees, and some use a die that cuts the ends into curved dovetails which fit snugly and help hold the belt firm when backed up with a short length of thin cloth, from 3 to 5 inches long. Have the cloth a little wider than the sand belt and trim the edges off to the exact width after the job is dry.

In gluing the backing cloth on, use a comparatively thin glue so as to not make the joint stiff or bulky, and spread glue on the backing cloth as well as on the section of the belt back to be covered by it. Smooth the cloth on the joint carefully, and then after it has dried a little it is well to clamp the joint between two pieces of board.

STORAGE BATTERY EXPLOSIONS

A considerable part of a service station's business sometimes consists in charging batteries. This is not a complicated operation since it consists only in making proper connections and turning on the current, and at the end cutting off the current and breaking the connections. During the process of charging, especially near the end, considerable hydrogen is likely to be generated, and a popular method of judging the state of the charge consists in noting the rate at which gas is liberated, as indicated by the bubbles. It may be difficult to observe this satisfactorily, even when the overhead lighting is good, and as a rule, the operator must resort to some form of portable illuminant. For this purpose the electric flash-lamp is strongly recommended. The use of an open-flame light of any kind, or the presence of lighted cigars, cigarettes, or pipes, should be prohibited. Most of the hydrogen that is generated is confined in the battery, and when the cap is taken off the gas escapes into the air. If a lighted match or other ignition agent is then brought near, it will be almost certain to set fire to the gas. The natural position to observe the gassing or bubbling is directly over the cell opening, so that in case of an explosion the operator's face is immediately in the path of the flame, and we have known of bad accidents resulting. The simple precaution of using an electric flash-lamp, or a portable electric incandescent lamp, removes all chance of an explosion.

SOME INFORMATION REGARDING CHISELS

(Continued from page 219)

case the steel is near $1 \frac{3}{8}$ to $1 \frac{1}{2}$ carbon there is danger of the fine grade steel cracking during the process. The word "temper" as used by the manufacturer, means the percentage of carbon it contains. For the chisel one percent carbon has great toughness in the unhardened state, with a capacity of hardening at a very low heat. This steel, unlike steels containing

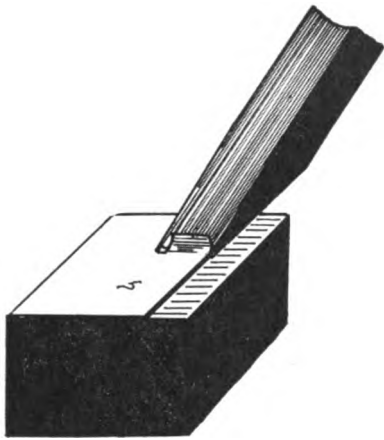

FIGURE 6, NO. 5

more points in carbon can be welded without difficulty. This one percent in carbon steel is a great deal more satisfactory for chisels or tools where a hammer is to be used than steels of the finer grade, as it will stand the hammer blow without springing or breaking if properly tempered. Seven-eighths percent in carbon is best to use if the chisel is to be subjected to unusually heavy, rough work, where the punishment is greater on the unhardened part of the chisel. This steel when made into the chisel will stand very heavy blows with the hammer.

To Harden the Chisel

The first step in preparing the chisel for use after forging will be to harden it in its entirety. Place the chisel in the fire and heat it slowly until it is a cherry red from end to end, after which it should be immediately removed from the fire and placed in clear water and left until the temperature is the same as the water. It is now very hard and would be of no value as a chisel for it would break into pieces should it be struck a blow with the

hammer. The next step will be to put the chisel through a process that will leave the one end hard for cutting other metals and the other end soft enough to withstand the blow of the hammer. Take the chisel just hardened and brighten the end to be used for cutting, on the emery wheel about two inches back and it is ready for tempering. Three—a number of methods of drawing the temper but the writer will give the one here that has been used with good success for a number of years. Heat a pot of lead over the fire until it will char a pine stick; take the chisel that has been hardened the entire length, and polished on the cutting end, and place the other end in the molten lead to a depth of about $\frac{1}{3}$ to $\frac{1}{2}$ of the length of the chisel. The color will soon begin to change high up on the polished portion of the chisel. The color will first be a very light straw and will continue to gradually grow darker and move farther toward the cutting end of the chisel. Now if the chisel is to be used for cast iron the color should be continued until it has a very deep straw color, having a greenish tint about one-fourth inch above the cutting edge. For cutting steel the color should be just a little lighter than that for cast iron and for wrought iron the color should be a deep blue with a greenish tint. In case it is a wood chisel the color should be stopped at a medium straw color. As soon as the desired color has been reached the chisel should again be plunged into the water and left until the temperature of the chisel is the same as the and the cutting edge ground to shape and it is ready for use. The various chisels tempered for the cutting of steel should be so stamped or marked so they will be used on steel and the ones for wrought should be so marked for a chisel tempered for wrought iron would not stand up well if used on a steel bar. The cold chisel is a tool just as much as the tap and die, or the drill bit and should have the same

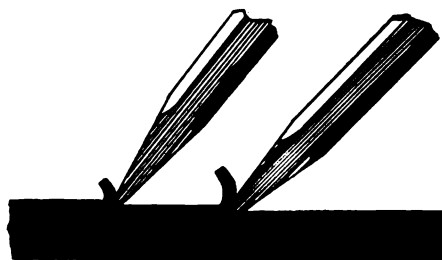
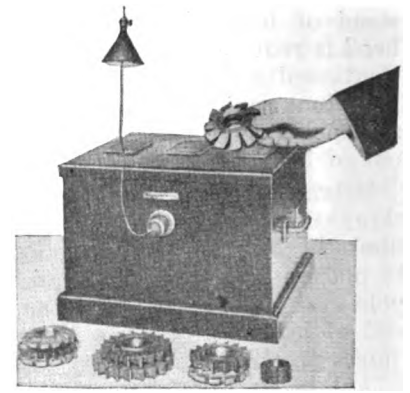

FIGURE 6, NO. 4



DEMAGNETIZER FOR CUTTING TOOLS

Milling cutters, drills, reamers, etc., from various reasons, occasionally become more or less highly magnetized so that chips adhere to them which are the frequent and direct cause of tool breakage. Many tool rooms have lately added a demagnetizing apparatus such as shown to their equipment. This device also plays a useful part in demagnetizing parts that have been held on a magnetic chuck.

careful attention given it if the best results are obtained from it.

THE SCOOTER IN LONDON

Many of the London papers have taken up the scooter as a lightsome topic and are quite enthusiastic over the possibilities of Londoners indulging in the weekend "scoots" to the nearest seaside and country resorts.

The scooter is generally considered in England as an absolute novelty but it is hardly that as a good number of similar machines are in use.

The type of scooter used by Sir Henry Horman who introduced the scooter to London, is the Autospeed, an American make, with the small single cylinder engine mounted on one side of the front wheel which drives through a pinion engaging an internally toothed drum carried by the wheel.

The arrangement is simple but I think the feather weight motorcycle a more practical type than the scooter with its standing position and toy engine.

However the progress of the mechanically driven scooter is worth watching and Sir Henry Horman thinks that given a fair trial this mode of conveyance is sure to make progress.

It is very important that regular inspections should be made of the leather coverings or boots, which protect the universals and other parts. Flying stones or sticks are apt to destroy these boots, permitting the lubricant to leak out and giving entrance to dust and dirt. Look them over once a month anyway.

DANGER FROM GARAGE PITS

The great danger of pits in garages for the convenience of mechanics in working under automobiles, has been recognized by a number of important cities, and they have passed laws prohibiting their use. It is evident, however, from a recent article in a building magazine that full appreciation of the hazardous nature of the garage pit is still lacking.

The magazine in question, in an article on rules for building garages, said, "A pit of sufficient dimensions to allow a person to crawl in it should be constructed. This device will permit the owner to lie underneath his car and enable him to make any changes which seem necessary. The installation of a drain at the bottom of the pit is very convenient."

Owing to the fact that gasoline vapor is heavier than air, it always seeks a lower level and collects in any pits and holes available, where it awaits the first accidental spark, carelessly thrown match, or other flame. Experience has shown that the necessary accident to cause an explosion always arrives sooner or later, and the use of garage pits has consequently been prohibited in a number of cities, including New York City and Newark, New Jersey.

ANVIL VISE

What ironworker has not sighed at times for a vise on his anvil! Here we have one that can be made to meet requirements and that fits into the hardy hole.

The set screw shown is for holding the vise screw in place and pulls

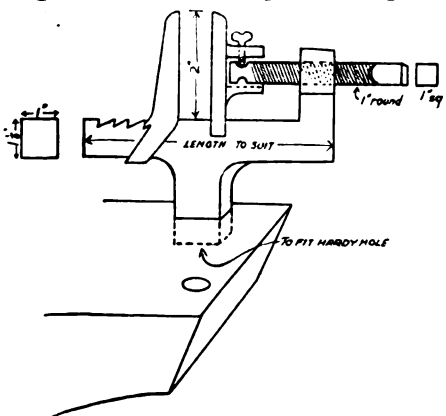

the jaw back and the large screw should not bear on the set screw when the jaw is holding a piece. The back jaw is movable for quick adjustment and should be designed so that it will stand straight when dropped in the notches.

J. W. Hepplewhite.

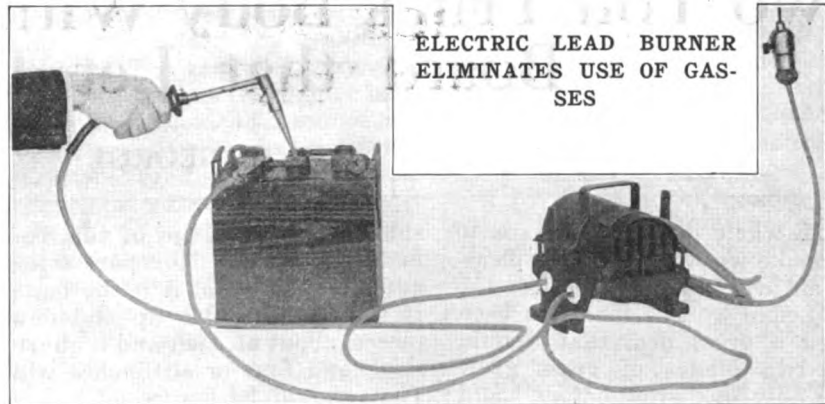

A recent production that is finding great favor among battery repairmen on account of its simplicity and economy of operation. The attachment and operation of the transformer are clearly indicated by the illustration.

MODERN HEAT TREATMENT OF STEEL

Before vanadium was got to unite with molten steel, steel of 70,000 pounds tensile strength was the limit. With vanadium added the strength was increased to 170,000 lbs. Vanadium is a rare metal which washes the molten steel of its impurities, brings the molecules closer together, and gives them a greater adhesiveness. A tougher, stronger alloy steel is the result. In looking at the construction of the modern automobile, it is evident that some parts must have great tensile, or pulling strength. Some must stand great torsional strains, that is must resist twisting; some must stand vibration, while others, like spring leaves, must be very flexible.

At times the same piece of metal requires a different sort of strength at different points, which involves a combination of two kinds of heat treatment.

The science of heat treating metals, modern heat treatment, has only been developed in the last ten years. Heat treatment gives strength to a bar of steel that was formerly unknown in a bar twice as large in diameter and weight.

In the heat treatment of forgings the first operation is usually to heat the forging and cool it slowly so as to anneal. This relieves internal strains and also softens the forging for machining. Parts that require little resistance against strain or wear require no further heat treatment. But in the modern engine, a number of parts must be case hardened after machining so that they have a hard, glass-like surface and a tough but less brittle core.

In case hardening the parts are

carbonized by packing them in charcoal and heating them to a temperature of about 1700 degrees. The hardening pots are hermetically sealed with fire clay to prevent the charcoal from burning. Under the heat the surface of the steel absorbs the charcoal, the depth of carbonizing depending on the time the parts are left in the carbonizing ovens.

After the carbonizing pots have cooled off naturally, the parts are removed and cyanided. They are suspended in pots containing molten cyanide of potassium. When withdrawn the parts are cooled off in oil or water according to requirements. This cyaniding process gives the parts a glass hard surface the depth of the carbonizing, while the core remains tough. In place of the cyanide process, in cases the case hardened part, when cool, can be reheated in an oven, while lying on fire brick, and then cooled off by dipping in oil or water. The cyanide process, however, gives a more even heat treatment and a harder shell on the metal. The registration of the heat in the furnaces is done by means of pyrometers, for a thermometer will only register accurately up to 500 deg. A pyrometer shows the heat accurately up to 3000 degrees or over.

It always pays to do one's duty. But the score is not settled at once—sometimes not for many years. In the meantime, there often seems to be loss in doing right, and the soul must be brave to meet this fact. As Stevenson says, "Tis a fine thing to smart for one's duty; even in the pangs of it there is contentment."

Two Ton Truck Body With Sides and Tail-Board that Let Down

M. H. GEORGE

THE whole idea nowadays is to make work easy and as pleasant as it can be made for the "hired man". The man has been praised a great deal that "could make two blades of grass grow where only one grew before" and the man who gets idea and puts it into effect where it will let one do as much work as two can do it, is worthy of praise, but I am not looking for that.

Auto trucks, are as a rule, in the same class as the average farm wagon, they are too high. If you are hauling things that do not require sides on the body, they are not so bad, but if you have sides that are from eighteen to thirty-six inches high and your load has to be shoveled in, it's a different matter. If there is only one man shoveling the load on he can stand behind and get along nicely, although it requires some muscle to throw a shovelful of coal into the front end of a twelve foot body.

It was with this idea of making it easier for the man that this body was built.

This description is for a body that will fit a two ton Reo truck, of course the measurements can be varied to suit the requirements of different trucks and the loads to be drawn.

This body was twelve feet long, so the first thing needed are two pieces of 2x6x12" lumber. These were laid on the sides of the truck frame, lengthwise. This was to be a permanent body, so we made four yokes out of half inch iron, notched them into the wood and bolted them solidly to the truck frame. This is better than drilling holes in the frame as it might weaken the frame. Then four pieces of 1½x6 inches and six feet long were bolted to these bed pieces. One at each end and the others an equal distance from them apart. These were for the floor to be bolted to, and bolts should be used in every place possible as nails will work out and catch on the shovels and cause a great deal of bother. The floor boards are now bolted to these cross pieces and should be of two inch hardwood stock, planed on both

sides. The front end of this body is bolted to the floor part solidly and the more solid it is the better. It should have two up and down pieces, about an inch and a quarter thick and four or six inches wide. They should be hardwood but the other boards may be soft wood.

Along the edge of this front end should be bolted a hardwood piece about two inches square. The cut will show it plainly.

On this body we made the ends so that the sides flared, that is the bottom was one foot narrower than the top. From the illustrations it

they are bent at right angles to bring the piece in line with the hole for the rod where it can be used. The rod used for these hinges should be at least one half inch diameter and I think that five-eighths would be better. A hole should be drilled a quarter of an inch from each end and a cotter pin inserted to keep the rod from working out. Care must be taken in spacing the hinges so that the two halves will be near together. A common hasp and staple was used to hold the sides in place and they should be made of three-eighths iron.

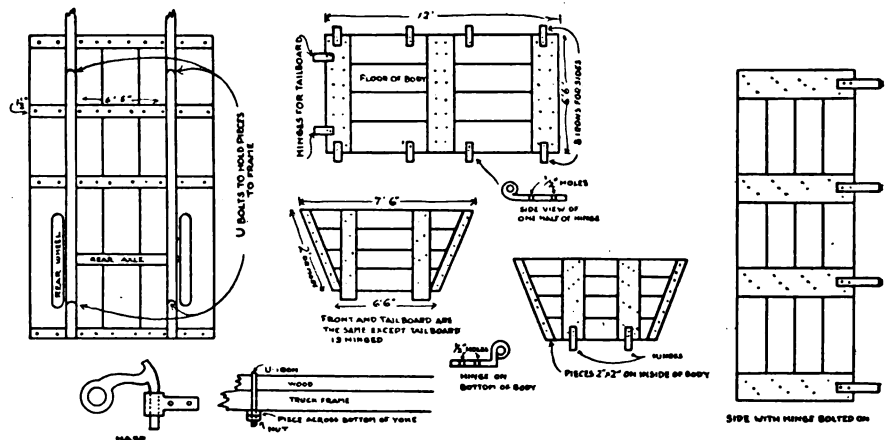

CONSTRUCTIONAL DETAILS OF TWO TON TRUCK BODY

will be seen that there are ten irons bolted along the sides and ends of the body. These are the hinges, or rather one half of the hinges, because the other half is bolted to the sides and the tail board. These are made of one half inch iron, two inches wide and the ends were forged and rolled up over to form the hole for the hinge pin to enter. These should be ten inches long when completed and have two one-half inch holes drilled in each. The sides should have four cleats or up and down pieces and these pieces should come where the hinges will be, also the lower board on each side piece should be of hard wood. The cleats should be on the outside both on the front and tailboard and the sides. A long rod that goes the whole length forms the hinge pins. The half of the hinge bolted to the is the same as the others only

For hauling coal or things of that nature the sides are apt to bulge out in the middle and to overcome this a chain was made with a hook on one end that could be hooked into a staple and this kept the sides where they belonged. The body should be wide enough so that when the sides are down they will not hit the wheels. Care should be taken in letting the sides and tail board down and not let them go down with a bang as they will soon be broken. It is very easy for two men to let them down.

Build Now
YOU CAN NOTICE THE
EARMARKS OF PROSPERITY
ALONG GOOD ROADS
U. S. Department of Labor
W. B. WILSON, Secretary

SHARPENING AND GRINDING RAZORS AND FINE CUTLERY

E. M. Peterson

Anyone possessing a fair amount of ability and has the ambition can set up in a corner of his shop the small and inexpensive apparatus necessary for the sharpening and grinding of keen edged cutlery such as razors, surgeon's scalpels, etc., that will surprise with the volume of work it brings both directly and indirectly.

The necessary equipment is confined to a properly graded assortment of grinding wheels and sharpening stones and polishing wheels that may be driven by foot or other power. A convenient arrangement of this character of the writer's own construction is driven by a $\frac{1}{8}$ horsepower electric motor, as shown in the accompanying illustration. Naturally the experience of the operator will determine the tools he needs for convenience and success and no hard and fast rule can be laid down for the equipment needed.

In the background of the illustration can be seen a 6 by $\frac{7}{8}$ inch wheel that is used exclusively for cutlery grinding and also a soft polishing wheel made of cloth and a wood wheel 2 $\frac{1}{2}$ by 1 inch covered with leather which does the rough polishing. On the spindle of the grinder shown is a very fine 2 $\frac{1}{2}$ by $\frac{7}{8}$ inch wheel that is used especially for very delicate grinding.

The most important thing is to have the wheel operate at a high rate of speed, at least from 1800 to 2500 revolutions per minute for grinding and polishing and the operator should take the lightest possible cuts when grinding in order that the work will not overheat.

(In another number Mr. Peterson has promised to tell more about the different materials, wheels, etc., and the manufacture of new razors.—Editor.)

REPAIRING ALUMINUM

Broken aluminum parts can be repaired successfully by welding. No little skill is required in doing the job, however, as the welder has to contend with rapid conduction of heat, contraction, and other peculiarities of the metal. With the development of a welding process by the oxy-hydrogen and oxy-acetylene flame, sheet aluminum readily can be welded and the seam dressed off so that the union scarcely can be located.

When working with aluminum, the processes used with other metals must be forgotten. Two castings may look exactly alike to the eye, and yet one may be twice as strong as the other. Aluminum will weld satisfactorily with the oxy-acetylene and the oxy-air processes, but to solder it requires considerable knowledge of its peculiarities. Many companies that handle large quantities of aluminum daily state it cannot be soldered. Others see no difficulty in doing the work.

The requisites for a successful operation are that the aluminum must be free from grease or other foreign matter and the solder must be correctly prepared or else some of its ingredients are sure to be burned. Most cases of failure in aluminum soldering, however, can be laid at the door of the operator. The part to be soldered is heated up to such a degree that a thin oxide is formed on the surface, and instead of soldering two pieces of aluminum together the operator does nothing but solder the two thin pieces of aluminum oxide together, and at the slightest strain they part. A flux composed of cadmium, 10 parts; zinc, 10 parts; tin, 10 parts; lead, 1 part, gives reasonably good results. Common

table salt is used extensively also as a flux for aluminum.

The machining of aluminum is difficult. It is a great tool heater, and in that way very much resembles copper. The work has to be carried on under a constant stream of cooling or lubricating agent, the most popular of which are a mixture of lard oil or kerosene.

In working aluminum small and light cuts must be taken, using turpentine, benzine or petrol as a lubricant, while the cutting speed must be high. For filing aluminum, a single-cut file will be found to last longer than a cross-cut. The file will become quickly clogged, cleaning can be carried out by dipping it in a strong solution of caustic soda and washing in running water, followed by rapid drying.

WELL; IT'S THE SAME OLD STORY

The Wheeling, W. Va., Intelligencer recently published a short article on the blacksmith business that we herewith reproduce as food for thought.

The blacksmith business has been a poor business during the past winter, as far as the managers and owners of those shops are concerned, as owing to the warm weather there has been little doing for the men who are engaged in the business of taking care of horses' shoes.

An Intelligencer reporter paid a visit to one of the shops a day or two ago and found several of the men making new shoes, while others were making repairs to parts for autos. "What are you doing in the horse shoeing business and how is business?" said the reporter and the blacksmith replied that there was nothing doing as far as horse shoe sharpening was concerned.

"Why last year an owner of a horse would have the animal in the shop from two to three times a week to have its shoes sharpened so that it could stand up on the slippery streets. This year, however, there has been nothing doing in that line and there has not been a horse in any of the shops to be taken care of. There is not a thing doing as far as blacksmith work is concerned."

COMPACT WATER BUCKET

To fill the radiator when out on the road, the most simple and the least bulky water container to carry can be made as follows:

Take a section of an old inner tube. Cement up one end. Cut the other end on a slant to make a nose like a pitcher. No further comments are necessary.

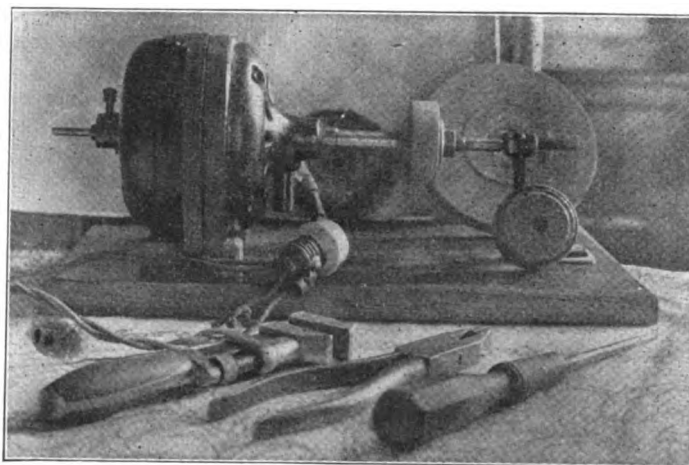

MR. PETERSON'S EQUIPMENT FOR GRINDING AND POLISHING FINE EDGED TOOLS

Drilling True Holes in Metal

C. H. WILLEY

THE method that this series of sketches show is not a new one, it is a trick all good mechanics have learned but very few practical workers of the home shop know about it, and it is something that they should know, for a hole that is drilled out of true in metal often causes great inconvenience and much trouble trying to set things right. By studying the nine consecutive steps shown here and

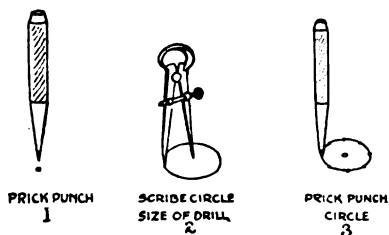

PROGRESSIVE STEPS IN LAYING OUT THE HOLE

practicing the method a few times on some old material one can soon become adept at the work.

The first step is that shown in Fig. 1. A prick punch with a slender, sharp point is used to spot the point where the center of the desired hole is to come. Strike the punch a light blow and make a mark just deep enough in which to place the point of one leg of the compass or dividers. Fig. 2 illustrates the next step. Set the dividers to scribe a circle the size of the drill. Place the point of one leg in the prick punch and scribe the circle clear. Next, as in Fig. 3, take the prick punch and mark the circle in 6 or 8 places plainly; these prick punches serve to identify the circle inside of which the drill must set. A center punch is now used to make a starting guide for the drill point, and its point is different from a prick punch in that it is broader and of less taper. It must be held squarely when struck, as shown in Fig. 4. The next Fig. 5, shows the starting of the drill and pictures it running off too much to one side. (In starting the drill it must only be allowed to cut a little way and then raised to see how it is going, as this illustration shows). The next sketch, Fig. 6 shows how to draw the drill over by taking a groover or half round nose chisel and cutting a groove down one

side of the started hole which then appears as shown in Fig. 7. This slot or groove makes the cutting edges bite more on that side and thus draws the drill over. Now when cutting that groove one must use judgment as to how deep to cut it, for it is possible to draw the drill too much, so when cutting a groove to draw a little, it must be shallow and also the size of the drill governs this rule. For large drills it requires deep slots, etc. When the drill is going true the hole appears as in Fig. 8 and when cutting full size it will just cut the prick punch marks of the scribed circle in half, as shown in the last sketch, Fig. 9.

SELLING FARM IMPLEMENTS

H. A. Law

MANY blacksmiths are implement dealers on a more or less extensive scale and in this article we will try to give some idea of the ins and outs of the farm implement business when conducted along with the blacksmith business.

In the first place we want to say that it is possible that conditions differ in the various states so that, as a whole, our argument will not apply to conditions other than here

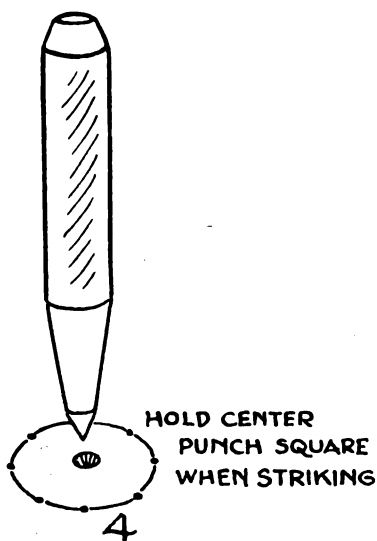

in northwest Missouri where the farmers live on farms and the men wear overalls and almost all of them travel forked end down. So we cannot account for nor deal with conditions with which we are not

familiar. Here we use almost any and all kinds of farm machinery that is manufactured as we, I say "we" for the country blacksmith must ally himself with the farmer and feel as though he was one of them before he really amounts to much, so excuse the term and consider that after all if you are not of some good to someone else we don't amount to much ourselves—but to

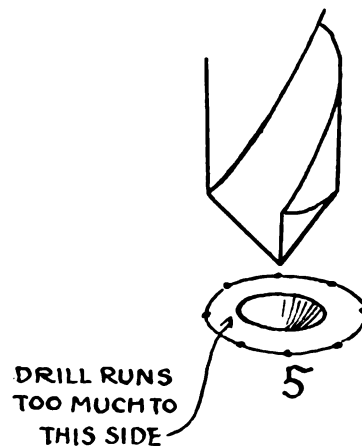

return to our subject. We do come as near to growing everything here that grows anywhere in the United States and we also have people who will try to raise or grow the limit.

From this it can be plainly seen that the dealer has to keep some stock on hand if he makes good in the implement business and to start with, a man must necessarily have more money than the average blacksmith has before he is able to do a general implement business as nowadays a man must buy his implements outright for cash or at least agree to pay for them within a certain time which is worse yet for him, as we would advise him first of all, if he has no money to let the business alone and we well know that if he does have plenty of money he won't bother with it unless some "friend" helps him into it.

Of course there is profit in the implement business but it requires money to handle it properly and it takes experience. Now, some might say, and we won't disagree with them, that we have had lots of experience. I personally, sold implements for 27 years in connection with the blacksmith business as well as two years spent on the road as an implement salesman and expert and at the end of 20 years I have come to the conclusion that if a man is a good blacksmith he must be something of a shoat to want anything better, as in the first

place if he works at the anvil himself he has no time for selling something that requires time to sell and his hard money to buy and then maybe sell to someone who could not borrow a dollar from the bank nor would try to do so without giving security, but who will come to you and ask you to trust him and you are afraid not to on account of the bill he owes you in the shop for if you make him mad he will quit you and you won't get it so you just take a long shot and get your feet wet.

Again he might be the best customer you have and you sell him a tool at a small profit hoping to thus show him you are appreciative of his patronage. The tool does not come up to expectations and you have sacrificed your profit and possibly one of your best customers as well and if that was all there was to it it wouldn't be so bad but his neighbor Brown just across the fence, who is also another good customer of yours, drives past your place the next day on his way to the "other" shop and you may never know the reason why. Perchance, if you should get the opportunity and ask him he will tell you he was in a hurry for his work and seeing you busy with a customer just thought that the other man was not so busy. Now, the real reason was the plow you sold Smith and Smith not only quit you but caused you difficulty to hold the business of Brown.

Fortunately your customers are not all Smiths nor Browns but

usually they are men who have the money and know what they want, they also know just about what it is worth and they also have the habit of buying it for a little less from your competitor either across the street or in the next town, because he has over bought and has to unload and your customer knows it. You may be in the same shape and so you feel you had better sell him at cost rather than carry it over until next season and here you have a customer who avails himself of the opportunities presented and if you don't believe they will present themselves our suggestion is—get into the implement business.

Possibly you think we have used up all the lamp-black we had but this is not the case but for fear that this article will get scattered around so far as to hinder the



farmers getting their implements or forcing them to buy from the mail order catalogue houses, we will say that a good business man with the capital and who has been in the same business or handled the same lines of machinery or who succeeds someone who has and is well acquainted with the different styles, dates and series of the machines and who knows the parts to stock and who is quick to order them and knows how and where to get them and doesn't try to take a hand at the anvil can do well and make a success of the business.

As for myself, I am at present handling nothing in the implement line outside of what I manufacture myself except pumps, pipe and fittings and I will say that I lost two customers over them last year besides three wrenches and a lifting jack which is as well as could be expected.

I would advise any blacksmith who is able to carry a good stock of machine repairs such as section guards, ledgers and fingers and wear plates as well as wrist pins and boxes, pitman rod ends, sickle heads, shift gears and any and all such parts likely to break and be in demand at harvest time as then these things are needed badly and the farmers haven't the time to wait if their machinery breaks down then. If you learn where

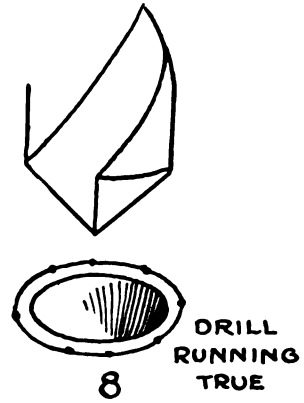

and how to buy and have a small amount of capital you can buy them in such a way that you have as good a show as anyone. There are several implement supply houses where such spare parts for almost any machine made can be obtained and now almost all heavy hardware houses are able to supply such parts. Of course you must keep these parts in stock and build up a reputation along that line and you will be surprised at the amount of that kind of business you will get. Another thing, make a specialty of refitting and rebuilding old machines and if you are any sort of mechanic the amount of this business you can obtain will be a revelation to you. Now is the time to begin. Start talking this idea to your farmer friends and urge them to bring their machines in and have them overhauled so that they will be ready when harvest time rolls

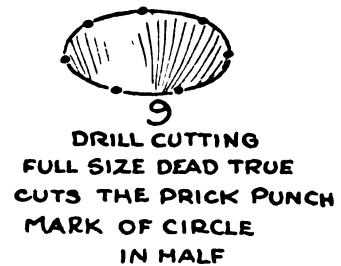

around and besides you will not be rushed to death during the harvest season making repairs that should have been made before. Also, the blacksmith has the advantage over the regular implement dealer of being able to install the parts that he sells or that the owner brings to him.

ACRES PLOWED WITH TRACTOR IN 10 HOUR DAY

| Miles per hour | Two 12" plows | Two 14" plows | Two 16" plows |
|----------------|---------------|---------------|---------------|
| 1 7/8 | 4.52 | 5.28 | 6.04 |
| 2 | 4.84 | 5.64 | 6.46 |
| 2 1/4 | 5.45 | 6.35 | 7.27 |
| 2 1/2 | 6.05 | 7.05 | 8.07 |

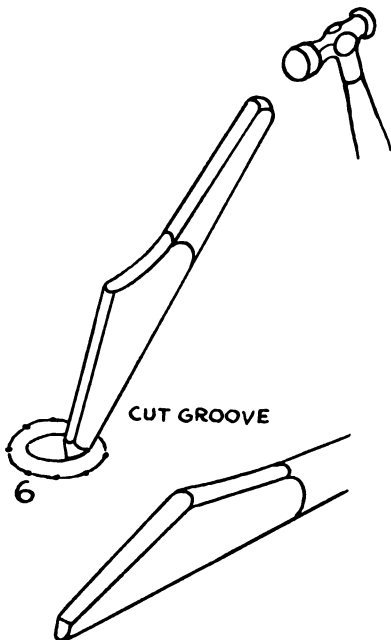

CHISEL AND METHOD OF TRUING UP AN OFF CENTER HOLE

ACCEPTANCE OF AN OFFER COMPLETES THE CONTRACT

There are many instances where disputes have arisen between a seller and a buyer because the seller wanted to withdraw an offer after it had been accepted by the buyer. In the majority of cases of this nature the acceptance is transmitted through the mails, and the seller has not received the letter of acceptance at the time he wants to call off the offer. Under such a condition he is of the opinion that as long as the acceptance has not been received by him he is at liberty to withdraw his offer. In fact there are very many business men who are of this opinion, and when such is the case it merely proves that they are not well informed concerning these points in the law of contracts. For this reason it will be interesting to business men and will no doubt amply repay them to read what the law is on such points.

When a seller makes an offer by letter and it is understood that the buyer is to accept the offer by letter, then the buyer's acceptance is binding upon the seller as soon as such letter of acceptance has been posted in the mail, even though the seller claims to have withdrawn the offer before the acceptance reached him.

This principle can best be illustrated by a case in point. Bradley wrote a letter to Stafford, making an offer of material at a certain price, with the understanding that the offer was to be accepted within one week from the date it was made. Stafford mailed his letter of acceptance on the sixth day following the date of the offer. Bradley did not receive this letter until four days later, and then he claimed that there was no contract because he had not received the acceptance in the time specified. The Court held that the acceptance was binding upon Bradley, because Stafford had accepted within the time mentioned in the offer. The contract arose from the time the acceptance was posted in the mail.

If, as Bradley claimed, he meant that the acceptance would have to be in his hands within seven days, then he should have stated this in making the offer. If he had done this he would have been amply protected. Instead of writing that the offer would have to be accepted within seven days, he should have written that the acceptance would have to be in his hands within that

time, and then Stafford would not have had any cause for action against Bradley, for it would have been plain that the acceptance had not been in accordance with the terms of the offer.

After an offer is properly accepted the seller can not call it off without being liable for breach of contract. The contract is then completed and it can not be cancelled unless both parties give their consent. If the seller does not want to be liable he must withdraw the offer before it is accepted, and give notice to the buyer of such withdrawal. An offer is not cancelled until the buyer receives the notice to this effect. Thus, if the seller decides to withdraw his offer and writes to the buyer that the offer is withdrawn, such a withdrawal is not effective until the buyer receives the letter. Even though the seller mails his withdrawal before the buyer posts his acceptance, the seller is still bound to fulfill the contract.

Jacobsen wrote a letter to Andrews in which was the following offer: "I will sell you ten gallons of White Cross liquid at ten dollars a gallon, but at this price I must have your acceptance by return mail". Andrews wrote and posted his acceptance immediately upon receipt of the letter containing this offer. Several hours later he received a telegram from Jacobsen, which read: "Offer for White

Cross liquid withdrawn". In this case it was plain that Jacobsen could not escape liability because Andrews had accepted the offer before he received notice of its withdrawal.

When the condition, "by return of mail", is made in an offer, it is usually construed as meaning, not the very next mail, but on the same day. However, in the case just stated, it was Andrews' prompt acceptance that completed the contract. If he had waited until later in the day, he would have had the telegram, and after that his acceptance would not have been valid.

In making an offer which should be accepted within a short time it is always advisable to state the conditions plainly, so that there will be no mistake in their interpretation. If a seller makes an offer, which is to be accepted within two days, he will protect himself by stating that the acceptance must be received by him prior to a certain time. If he merely states that the offer must be accepted within two days, and the buyer does not post his acceptance within this time, but the letter is lost and never reaches the seller, it may still be possible for the buyer to claim breach of contract because the seller does not fulfill his part of the contract.

Where the Contract Arises

Occasionally it is necessary to determine where a contract arises, since the laws of various states differ, and the enforcement of the contract depends upon the laws in the state where the contract arose. The established rule in such cases is that the contract arises at the place where the offer is accepted. If a Philadelphia seller makes an offer to an Omaha buyer, and the acceptance is posted at the latter place, then the contract is completed at Omaha, and the laws of Nebraska must be relied upon if any difficulties arise in the enforcement of the contract. The reason for this rule is that the acceptance is necessary to complete the contract, and at the place where the contract is completed, there the contract arises. This rule holds good when acceptances are made by letter, telegram or telephone. When the parties are dealing face to face, the place where they are at the time the agreement is made is the place where the contract arises.

CLAMP FOR HOLDING LARGE SHAFTS

Quick work is often required in hardening and other manipulations of large shafts and the holder illustrated makes the handling of such large pieces a simple matter.

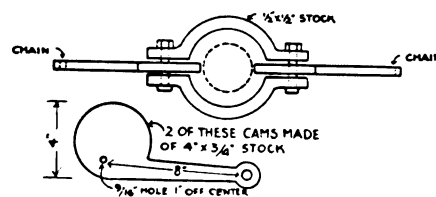

The two cams are attached to two chains. The ends of the chains are attached to a ring and a simple pull of the ring tightens up the cams on the job. I have let a 175 pound roll drop 20 inches and the device shown held. My clamps are $5\frac{3}{4}$ inches inside diameter and will hold pieces from $3\frac{1}{2}$ to $5\frac{1}{2}$ inches. J. W. Happlewhite.

Queries-Answers-Notes



THIS department is the meeting place where you are free to ask for information, answer questions, discuss shop matters and business conditions and any other notes you feel would be of interest to a fellow mechanic. Make use of this Department as often as desired.

INSURANCE

"We at one time had picked up enough until we lost about \$16,000 by fire and as we had very little insurance the loss was practically a total. We were located in a small town with no fire fighting equipment and consequently the insurance premium ran up to about 5½ per cent—we thought we could not afford it and allowed our insurance policies to lapse until practically none remained—then the unexpected happened, we paid the price of our "chance."

"No one needs to take such chances as when a man past 40 years of age loses all he has, if he has anything worth losing, the chances are that he needs a new spark plug."

—H. A. Law.

Hardening of Welds—After welding a piece of cast iron it becomes so hard that a file or drill will not take hold of it. How can this be remedied as I have a great of this class of work to do and it is almost impossible for me to bore holes in it.

G. Koppius, Alabama.

Each time that cast iron is melted (or welded) it becomes harder and unless particular care is used to prevent rapid cooling, the proper rod and flux will not prevent hardening.

As we have noted that cast iron becomes harder each time that it is welded it becomes necessary to use a special filling rod containing at least 35 silicon which tends to soften the weld and as it is the material from this rod that constitutes the weld, because the old metal has been grooved out before welding, the weld is soft and workable if it is cooled slowly. If it is necessary at any time to reweld, grind out the metal. Do not depend upon the force of the flame to get to the bottom of the weld, since this course is almost certain to produce brittle iron, as the old metal is not removed but simply melted.

A few additional suggestions for welding cast iron to which are important to observe are:—

First—see that a neutral flame is maintained at all times.

Second—keep the white cone of the flame about ¼ inch from the metal.

Third—use a clean high grade welding rod, free from dirt and with a silicon content of about 3%.

Fourth—use only enough flux to make the metal flow and insist on a flux from carbonates.

In using the flux, the welding rod is heated and dipped into the can when enough should adhere to the rod. If the iron is unusually dirty it may be

found advisable to sprinkle some flux on the weld with the fingers, but too much should not be used.

Blacksmiths Meet—Carl D. Glick, was elected president of the Washington State Association of Blacksmiths. C. C. McCoy, secretary-treasurer; A. F. Kohler, P. D. Mann, A. C. Busby, vice presidents. Among other things the convention declared for the construction of separate roadways for horses.

Steam Automobiles—Having noticed in your April number an article dealing on steam driven automobiles could you give me any information as to the manufacturers of the Stanley engine or a description of the make of car or picture of the car with the engine installed ready for the road, also manufacturers of cars using steam engines instead of gasoline.

M. J. MacLean, Canada.

The Stanley Motor Carriage Co., of Newton, Mass., manufacture their own engines. The two best known steam cars are the one just referred to and the Doble-Detroit, manufactured by the Doble-Detroit Steam Car Co., Detroit, Mich. On

up and bled. So who's right? The case we got into the argument over was that of a horse that picked up a nail in the point of the frog. I went ahead and burnt it out and the next day the pus started to flow and then I went ahead and washed it with a disinfectant, packed the foot with pine tar and oakum and the horse is working O. K.

Albert H. Armstrong.

A's treatment is all right although we believe that the same effect would have been obtained by thoroughly cleansing the injury with a proper antiseptic without the cauterizing. In the case of a nail injury such as the one mentioned it might be even necessary to open the wound further so that it could be thoroughly cleaned out. While cauterizing serves a useful purpose it occurs to us that it is used entirely too generally and also more or less indiscriminately. It is quite likely that the blacksmith would resort to "burning" a similar injury to his own foot.

B probably believes that by opening the wound and causing it to bleed that the flow of blood would carry out with it any foreign matter that might have been introduced into the injury by the nail. All injuries whether they bleed or not should be promptly dressed by first applying antiseptics or other treatment as the case may require.

And We Think Prices Are High—As an indication of what prices for all kinds of material are in this part of the world permit me to relate the following:

In March, 1910, we built and sold a bow wagon for 40 pounds. Recently the same wagon was resold after nine year's use at the astonishingly increased price of 75 pounds.

W. G. Hart, Australia.

The Auto Won't Kick Brother—"Please do not send any more papers to me as I



"THE FIX IT SHOP" OF GRAHAM & SMITH IN AUSTRALIA. MR. SMITH, WHO IS LEANING AGAINST THE DOOR IN THE PICTURE IS A MEMBER OF THE MOTOR TRANSPORT SERVICE IN FRANCE. THIS PICTURE WAS TAKEN BY THEIR ASSISTANT WHO IS ALSO SOMETHING OF A PHOTOGRAPHER. ONE OF THE INTERESTING FEATURES OF THIS PICTURE IS THE UNUSUAL AMOUNT OF "WEATHER" GIVEN TO THE SHINGLES OF THE ROOF

application to the manufacturers of these cars they will cheerfully furnish you with complete illustrated descriptive matter regarding their cars, construction and operation.

We're Called to Settle a Bet—I have a little argument I would like to have your opinion passed upon. A says it doesn't hurt to burn out a nail puncture in a horse's hoof and that is one of the best ways to stop poisoning.

B says it's wrong and should be opened

do not get any good of it any more as you know the horseshoeing game is shot and the paper is all auto stuff now and I don't want anything to do with an auto."

M. R. Kielblock, New Jersey.

A Letter of Another Sort—This one comes from Mr. H. A. Law whose state emblem is popularly supposed to be a mule rampant above the device "Show Me." Mr. Law is a blacksmith and wagon maker and besides the vehicles or his own manufacture he sells vehicles of standard

makes, all kinds of farm implements and machinery, pumps and supplies, does oxyacetylene welding, lathe work and rebuilds and repaints automobiles and we are glad of this opportunity to give a description of Mr. Law's shop and some of his observations.

"We have been in the blacksmith business for 34 years and although I am more than 50 years of age we have done about \$41 worth of work today. We have two fires but only keep a helper and we accomplish this saving in labor by making machinery do all that machinery can do and this is much cheaper than labor and more satisfactory.

"We have a trip hammer, and a big shear, power drill and power blowers, a 14" swing, 8' bed lathe, disc sharpener, emery grinders; a large one for plows and a small one for tools and plane bits.

"Since we installed our oxyacetylene welding equipment we are getting work from 10 miles around. Our wood working equipment consists of a 36" band saw, 12" jointer, a double spindle shaper and mortising machine, spoke driver and tenoner. A feed mill with stone burrs for making meal is also a part of our equipment and we require for power purposes two engines, one of 15 horsepower and the other of 2½ horsepower using gasoline for fuel."

In his letter Mr. Law stated that he would be glad to have our suggestion for an article and we have asked him to favor us with something on his experiences in the farm implement business and doubtless this article will be a source of much interest to our readers, inasmuch, as this is a profitable line which the blacksmith is well equipped to handle.

Partnership Formed—"We count the Auto & Tractor Shop a good paper with lots of helpful information in every number. We have formed a partnership and have two full sets of blacksmith and wood-worker's tools, two fires, gasoline engine, two emery grinders, planer, band saw, rip saw, power grindstone and No. 18 power drill. Also, and what is more to the point we have lots of work and get good prices for it."

Dimmett & Wilhelm, Indiana.

Fire Don't Weld—My fire refuses to weld unless I put salt on it. What causes this? There is a very heavy coat of something gets on the iron like scale.

S. E. Frazell, Nebraska.

We're rather inclined to think that there is a large amount of sulphur in the coal that you use and sulphur as we all know will make welding very difficult if not impossible. Sulphur will also leave a coating on the iron and it is possible that the salt which is added will cause an additional deposit.

The excellence of the coal used can be determined by watching how the fire burns. If it sometimes gives a hot fire and sometimes not; if it comes up fast and rapidly dies out; if the flame is red edged with blue; if the coke that is formed is dark colored and easily crumbled then the coal is of inferior quality.

To test the coal take several pieces about the size of your fist and break them open. If little white scales or brownish yellow deposits appear between the layers, they are sulphur and will absolutely prevent good welding.

A blue edge around the flame indicates a large amount of sulphur. A suitable smithing coal, being practically free of

sulphur, makes a pure red and yellow flame.

Cleaning. Concrete. Floors—I will be obliged if you will tell me what acid to use to remove grease and grime. There is quite a large area to clean and the floor is quite dirty.

W. D. McGurn, New York.

The best method of removing grease or oil is by the use of some caustic alkali, preferably applied hot and of such, strong lye solution is probably the best known and cheapest. We are familiar with the fact that many advocate the use of acid



A Bush Fire Cart. An Australian bush fire is something of a proposition to combat and so the colonial government provides rather elaborate equipment. This picture shows Mr. T. H. Graham and a bush fire cart that he built from the ground up and is an excellent example of unusual work.

in some form or other for this purpose but acid will not remove grease—as a matter of fact grease of different kinds is used in a great many instances to give protection against the corrosive effect of acids. If we want to remove a heavy coat of axle grease from our hands we use soap because of the alkali in the soap and the greater the amount of alkali the quicker the action. If it is desired to remove oil or grease from machined castings they are dipped into a hot solution of potash or lye.

If it is merely desired to remove the grease we would recommend a hot solution made in any strength—the stronger it is the easier the grease will be removed—made from lye, potash or any of the compounds that are on the market for cleaning castings, etc. If it is desired to whiten the concrete a weak solution of sulphuric acid and water will exert a slight bleaching effect. The use of strong lye solution is also said to be helpful where concrete floors "dust".

Criticism is Valuable—No blacksmith ought ever to be afraid of criticism. Just as soon as any man tries to do anything

different he will stir up a lot of criticism. But criticism is like weeds—full of valuable fertilization. Just plow it under and let it fertilize your thinking. It is the best educator on earth. Everything the leaders in modern industry have learned has been through criticism that induced them to think.

How to Line Up the Front Wheels.—The front wheels will occasionally be thrown out of alignment, due to striking some deep depression in roadway, side-swiping a curbstone, etc. Line up your front wheels as follows: Produce a straight edge and place it about the center of the wheels directly in front of front axle, allowing one side to rest against wheel rim. Mark off distance and place straight edge in back of front axle, being careful to take your measurements from precisely the same location as taken between the wheels directly in front of front axle. The measurements in front should be from ¼ to ⅜ inch, shorter which is correct. Clevis on cross tubes are generally provided to make any necessary adjustments for lining up the front wheels. Remember, if the front wheels are running out of alignment, it will wear the tires.

Drawing Temper in Sand—It is often difficult, after hardening small, thin pieces of steel, to draw them to the required temper without unevenness. Flames and fires are apt to be hot in spots or so intense that the article is not heated evenly. To avoid this, heat sand in a metal dish and dip the article in it, moving it continually until the required color is obtained. The sand must not be too hot, and the article must be bright.

Repair of Broken Carburetor Glass—One night I had a customer come in who lives about 25 miles from our shop. He had, in trying to close the strangler on his Stromberg, carburetor, hit the glass float chamber with a wrench and broken it.

The hole was large enough to put your finger through, and was within ¼ in. of the bottom, so of course he could not keep any gasoline in the chamber.

It was up to me to get him home, so I took a piece of tough wrapping paper and coated it good on one side with liquid shellac and pasted it on the glass over the hole and let it dry. Then I took dry shellac and melted and spread it all over the outside of the paper with an old hack saw blade, which I heated with a blow torch.

I put the shellac on until I had it about 1-16 in. thick all over the paper and then worked it over the edges of the paper so that it sealed it down tight.

When I put the carburetor back on and turned the gasoline on there was not the least sign of a leak and my customer got home all right.—Geo. H. Eastman.

The Withrow Garage

Agents for

The Inter-State, Chevrolet, Columbia Six

General Repairing, Painting, Expert Service

Warren W. Morse, Prop.

A MINNESOTA CONCERN THAT IS MAKING A BIG SUCCESS OF AUTOMOBILE WORK OF ALL KINDS

AMERICAN BLACKSMITH AUTO & TRACTOR SHOP

VOLUME 18

JULY, 1919

NUMBER 10

BUFFALO, N. Y., U. S. A

Established 1901. Published Monthly at the Sidway Building, Buffalo, N. Y., by the

AMERICAN BLACKSMITH COMPANY

Incorporated under New York State Laws.

WILLIAM F. WENDT, *President.*

WALTER O. BERNHARDT, *Editor.*

SUBSCRIPTION PRICE:

For \$1.00 per year, payable in advance, The American Blacksmith, Auto & Tractor Shop will be sent, postage prepaid to any postoffice in the United States. To Canada, \$1.25; to other countries, 6 shillings. Reduced rates to clubs of five or more on application.

Remittances may be made by money order, express order or checks payable to the American Blacksmith Company. We will also accept uncanceled postage stamps or currency, but for safety these should be sent by registered mail.

Subscribers should notify us at once of non-receipt of paper or change of address. In latter case, give both old and new address.

Correspondence on all smithing subjects solicited. Always give name and address, which will be omitted in publishing, if desired. Address all communications to the

"AMERICAN BLACKSMITH COMPANY"
BUFFALO N. Y

Copyright W. F. Wendt Publishing Company, 1919 "

Cable Address: "Blacksmith, Buffalo"



"IF WE DO NOT HANG TOGETHER WE SHALL ASSUREDLY ALL HANG SEPARATELY."
—John Hancock

WHEN it came to signing the Declaration of Independence there were visible signs of faltering on the part of some delegates and someone—Benjamin Franklin, we believe it was—urged that "we must all hang together", to which John Hancock at once promptly replied, "If we do not hang together we shall assuredly all hang separately", and he then proceeded to affix his signature to the document so boldly that he said, "the King of England can read it without using his spectacles."

"We must all hang together" is a statement as significant to us today as it was then, in order that we may effectively combat and destroy the radical movements that have been transplanted to our shores from "enlightened" Russia and Germany, and to prevent America's liberty of speech and press from being translated into the license to preach those doctrines of destruction and individual irresponsibility that characterize the brand of raging, seething, anarchic chaos that regards neither the life nor honor of man or woman or the ownership of property of whatsoever kind.

Whatever they call it—Socialism, Bolshevism, Communism, Townleyism, I. W. W.'ism or any of the other "isms", they are individually and collectively a menace—a serious and dangerous menace that deserves no more consideration than a deadly serpent whose destruction means safety for the individual and national good.

German propaganda that we fought against during the war at its worst was mild compared to that now with us and the sooner we realize the danger of the menace, the better for everybody—the time has truly come when "WE MUST ALL HANG

CONTENTS—JULY, 1919

| | |
|-------------------------------------|-----|
| Saw Fitting for Best Results..... | 237 |
| Polishing Walnut | 239 |
| Welding a Tractor Bull-Gear..... | 240 |
| Electricity for House Shop and Farm | 242 |
| Abusing the Automobile Top..... | 243 |
| A Public Nuisance | 244 |
| Cobalt | 245 |
| Three Helps | 245 |
| Benton's Recipes | 247 |
| Keeping Track of the Business | 250 |
| Kinks and Shop Notes | 252 |
| Assembled Automobiles | 254 |
| Drilling Hard Cast Iron | 254 |
| Ford Electrical Ailments | 256 |
| What Constitutes Forgery? | 258 |

TRACTOR SAVED THE DAY

S. T. Erickson of Allamakee county, Ia., invested in his first tractor a little more than a year ago. When harvest time came he was extremely short of help, but didn't miss it, for his thirteen-year-old son and the tractor saved the day. He put the boy on the tractor with two binders attached to the machine. The first day between 9 a. m. and 6 p. m. the boy cut thirty-six acres of oats. Mr. Erickson figures that he and the tractor did the work of eight horses and two men.

"And he didn't leave strips at the corner either," says Mr. Erickson.—Farm Journal.

DON'T GIVE MONEY TO AGENTS

The American Blacksmith, Auto & Tractor Shop DOES NOT employ subscription agents. Any person representing himself as such is an imposter and should be so dealt with. Notify us immediately if anyone claiming to represent this journal calls upon you.

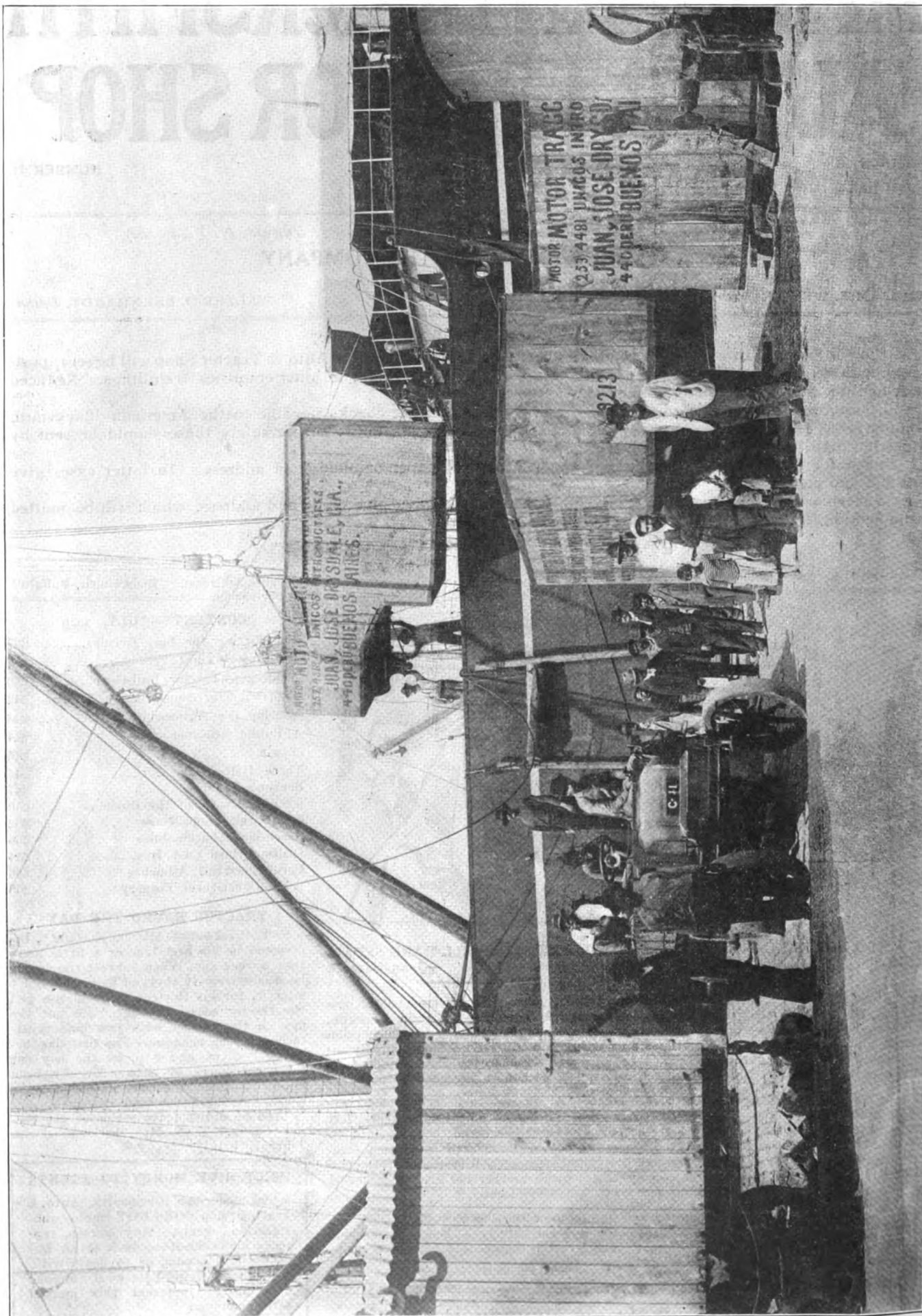

There are still people who believe that South America is inhabited by savages attired in neat fitting smiles or at the most, a grass mat, and that plowing is done with a crooked stick. Here we see "Made in U. S. A." tractors being unloaded at Buenos Ayres in Argentina. On account of their energy and progress in all directions the Argentines have been aptly termed "the Yankees of South America." Also, the oldest inhabitant can't even remember a revolution. Tractors are popular but their use is hampered by the high cost of fuel which is all imported.

Saw Fitting for Best Results with Cross Cut and Drag Saws



THE best band saw in the world, pulled by the best sawyer, cannot do efficient work unless the teeth are kept in proper shape to cut and rake out the sawdust. The best saw filer must have proper gauges and tools, or he cannot do his work accurately.

We must illustrate the fitting of saws by illustrating the use of proper saw-fitting tools. Fitting cross-cut saws is based on a few well-known principles. With these principles in mind, slight variation must or can be made in the bevel of the teeth, shape of the teeth, angle of the cutting point, shape and length of the raking or clearing teeth to suit local requirements. These slight variations are made expedient by reason of the fact that it is necessary to adapt the saw for cutting in different kinds of wood; sometimes hardwood, sometimes soft or frozen logs, knotty logs, and logs that are full of pitch.

The principles involved in making the teeth of cross-cut saws are as follows:

1. The cutting teeth constitute a series of knives adapted to sever all fibers of the wood. When these fibers are cut through they must be collected in the gullets of the teeth, or dust chambers, and car-

ried out of the kerf, so as to enable the saw to freely start in on a new cut.

2. The clearing teeth constitute a series of rakers to free the kerf from the dust or shavings that are severed by the cutting teeth.

With these principles in mind we come to the preparation of the teeth for the work:

1. All cutting teeth must be the

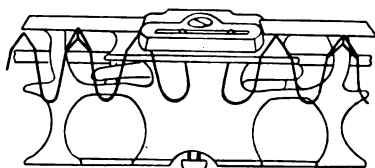

FIG. 1.—SAW JOINTER

same length, so that each tooth will do its share of the cutting, and no more.

To make all teeth the same length place the saw in a vise, or, if the filing is to be done in the woods, where no vise is available, place the blade, teeth uppermost, in a notch in a convenient stump, pass a file carefully over the teeth, as shown in Figure 1, until all teeth touch the file. This can readily be determined by the bright, flat tops on the cutting teeth.

Care must be taken to hold the file squarely, so that the cutting teeth on each side of the saw will be the same length. If the file is allowed to pass over the teeth at an angle, one side of the saw will be longer than the other, and this will invariably make a saw run to the side which has the longest teeth, as this side cuts faster.

2. When all of the cutting teeth are even on top, the next operation should be to regulate the length of the rakers or clearing teeth. We advocate regulating the length of the rakers at this point, because the rakers should be adjusted by gauge, and any tool which is used for this purpose would have a tendency to dull the sharp points of the cutting teeth if it was used after they had been finally finished.

This operation is one which requires the same accuracy and attention to details. Experience is the best teacher in determining the proper length of rakers, as compared to the length of the cutting teeth. It is essential for good cutting that the rakers should be some shorter than the cutting teeth—not less than 1/100 part of an inch, nor more than 1/64 of an inch. If the rakers are to be swaged, it is proper to leave them the same length as

the cutting teeth and allow the swaging to shorten them sufficiently for good work. Unswaged rakers should be cut off accurately to gauge, as shown in Figure 2.

The saw teeth will now look like Figure 3.

3. The next operation consists of filing up the rakers to a keen, sharp edge, using care that their tops shall be square with the side of the blade. It is necessary to point up the rakers in this manner, whether they are to be swaged or not. (Fig. 1.)

4. After determining the shape you desire in the cutting teeth, proceed to shape them to suit you before starting to bevel. It is much

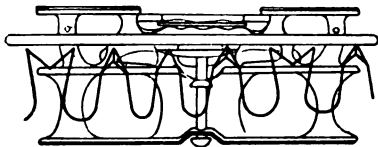

FIG. 2—RAKER GAUGE CUTTING DOWN RAKERS

better to preserve a uniform tooth formation, and to use that which is best adapted to the various kinds of wood, as can be seen in the different styles of teeth shown at the end of these instructions. Shaping of the teeth should be done at right angles to the teeth, always making square lines, not attempting to do any beveling until all teeth are formed. Carry the square shape up to the point of the teeth. It is important to square up the cutting teeth of a cross-cut saw from the same side of the teeth that you intend to do the beveling. The reason for this is that it is very difficult to handle a file on a thin cross-cut saw absolutely square across the saw, without having it chatter more or less. In the effort to keep the file from chattering you will naturally lean the file slightly toward you at the handle end, which

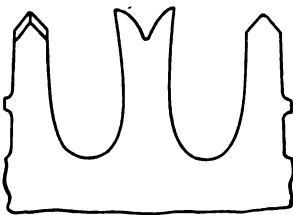

FIGURE 3

will form a slight bevel on the teeth.

5. You now have your teeth the right length and the correct shape, and can proceed to bevel. The

amount of bevel required can be determined by your own experience, and by reference to cuts of various bevels shown at the end of these instructions. Care must be taken not to cut off the points of the teeth, in beveling.

To make a flat, straight, bevel a full, straight stroke of the file is necessary, but if a rounded bevel is wanted to follow a round-tooth formation (Figs. 14, and 15), it is necessary to roll the file, following the contour of the saw teeth.

File all cutting teeth to a sharp point.

Your cutting teeth should now be finished, and if you are using unswaged rakers your rakers are finished and the saw is ready to set.

If you are using swaged rakers, you are now ready for the swaging process.

6. Swage the rakers with light blows of a light hammer, using care not to spread the point of the raker to a thickness exceeding that of the saw plate. This can be done by inclining your hammer slightly, as shown in Figure 4.

This will give your raker teeth a formation as shown in Figure 10.

An unswaged raker breaks up the fibers which are severed by the cutting teeth into short pieces, which are more apt to pass by the

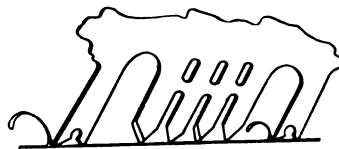

FIGURE 5

side of the saw and cause the saw to bind. Whereas, swaged rakers act as a plane on the bottom of the cut, going under the severed fibers and planing out the V-shaped chip left in the bottom cut. See Fig. 5.

Your saw is now ready to set.

7. The amount of set necessary is determined by the kind of material to be cut. Perfect alignment is absolutely necessary. Therefore, always use the set gauge as shown in Figure 6.

The operation of setting can be accomplished in several ways. If filing is done in the woods, the saw

can be set by what is usually termed a stump set. See Figure 8.

The point of the tooth should project about $\frac{1}{4}$ inch over the apex of the setting block, and the setting should be done by means of a firm, sharp blow on the top, just at the place where it rests on the apex of the setting block. If too large set is imparted, reduce the set by hammering the tooth placed on the flat surface of the set-block. If too little set is imparted at the first blow, reset the tooth as in the first operation, either using a little harder blow or allowing the tooth to project a little farther from the apex of the anvil.

Each tooth, after setting, should be gauged for accuracy, as shown in the cut illustrating the use of a set gauge. (Fig. 6.)

A number of cuts showing the principal forms of saw teeth, both cutting teeth and rakers for different kinds of timber and different requirements.

You will note by carefully study-



FIGURE 6

ing the different forms of teeth and the different beveling, that the same principle is involved in each case, but different methods are employed to cover special requirements.

In frozen timber, exceedingly hard wood, or wood that has many hard knots (See Figs. 13, 14 and 15,) you will find that it is always

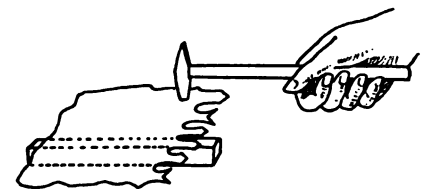
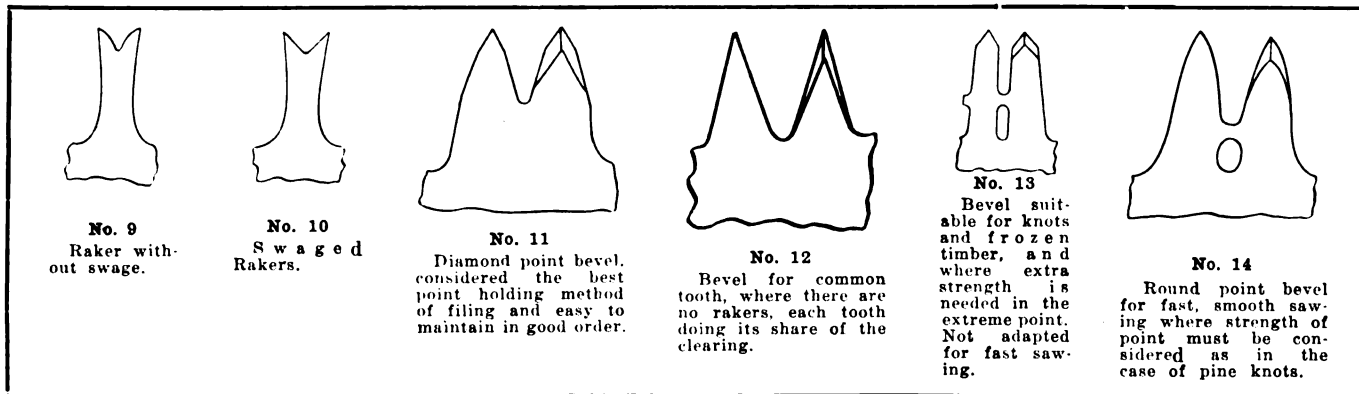

FIGURE 8

better not to make the bevel too flat. Yet by following out the lines laid down in rounded-point beveling (Figs. 14, 15), you are able to secure a fast-cutting saw with plenty of bevel, without the danger



of leaving the extreme point of the tooth too weak. In other words, a rounded-point beveling will leave more backing to the point of the tooth than a flat bevel, and still leave the saw in shape to do fast cutting. It is considerably more work, however, to file a saw with a rounded point than a saw with a straight, flat bevel.

If your saw has a tendency to lose its points, we would advocate reducing your bevel or perhaps increasing the angle of your cutting point. In hard hemlock knots the points have a tendency to bend. Very often with a little less bevel your saw will stay sharpened twice as long, and will cut just as fast, and preserve its points. We would always advocate filing the saw with as much bevel as possible, consistent with leaving enough backing to the point of the teeth so that the point will neither bend nor break off in striking small knots in such timber as hemlock or hard woods.

There are many who advocate beveling the teeth clear down to the gullet, but such beveling necessitates extra filing, which is unnecessary, as the point of the teeth is the part of the saw which does the cutting. Each stroke of the saw only allows the point of the teeth to sink as far into the wood as the wedge-shaped point of the bevel will allow it. This is governed to a certain extent by the action of the

rakers, which are clearing the cut ahead of the cutting teeth, but as a rule one stroke of the cutting tooth of a cross-cut saw will carry each tooth only down to a point where the bevel causes the tooth to wedge into the cut.

Always set your saw wide enough so that it cuts freely, but do not set it wide enough to chatter, as every 1/1000 part of an inch means an excess of power required to pull the saw, as the cut is just that much wider.

In frozen timber, properly ground saws ought to work with very little set. In hard woods they require very little; in pitchy pine woods the saws usually require a little more set, but if they are kept well cleaned, a saw set for hard wood ought to cut in yellow pine.

**OF WHAT SHALL A MAN BE
PROUD IF HE IS NOT PROUD
OF HIS WORK?**

POLISHING WALNUT

Black walnut will have the appearance of rich old wood if treated with this polish; Apply to the bare wood, after making it smooth and clean a thin coating of brown shellac varnish, and while still moist rub it with a piece of smooth fine pumice stone until it is dry. Apply another coat of shellac and rub as

before. Then it is ready for the polish, made as follows; Mix together raw linseed oil, turpentine, and beeswax to form a paste, and apply by means of a rubber. The surface may not be smooth enough after the pumice stone work. If so, then rub with fine glasspaper until the polish again. In time the wood it is smooth then polish again. In time the wood becomes very dark and rich looking, and the finish is superior to a varnished effect.

COLOR AND HEAT

For the color which corresponds to the various degrees of temperature Fahrenheit, the following table is given as being closely accurate. It may be of use to the blacksmith who desires to give a specific heat in any work:

| | |
|---------------------------------|-----------|
| | Deg.Fahr. |
| Lowest red visible in the dark. | 635 |
| Faint red | 960 |
| Dull red | 1290 |
| Brilliant red | 1470 |
| Cherry red | 1650 |
| Orange | 2010 |
| Bright orange | 2190 |
| White heat | 2370 |
| Bright white heat | 2550 |
| Dazzling white heat | 2730 |
| Welding or scintillating heat | 2800 |

—o—
Don't estimate people by some outside quality, for it is that within that makes the man.

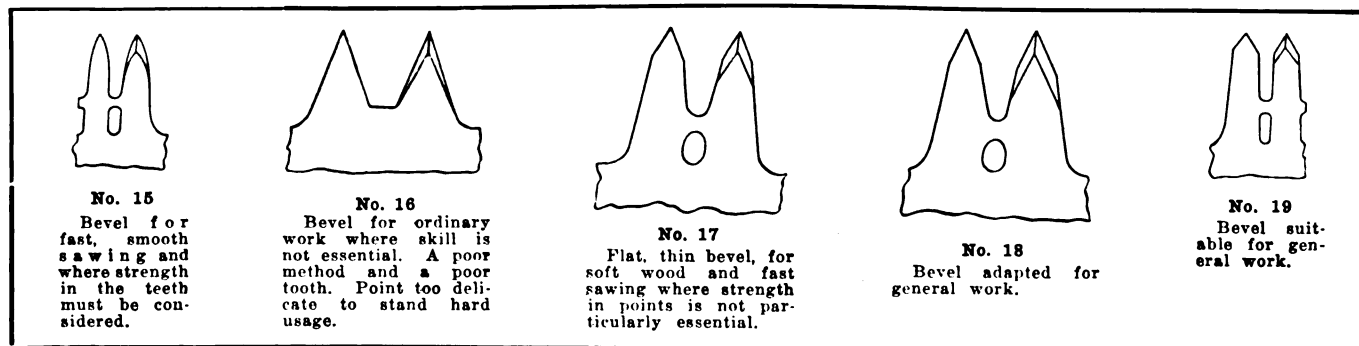

Welding a Tractor Bull-Gear

DAVID BAXTER

THE wise blacksmith or repairman who can look a little into the future and who is familiar with conditions as they are today will prepare to know as much as possible about tractors, their running and repairing. He will prepare to get his share of the work necessary to keep these machines in good running order. He will learn as much as possible about the different parts and how to make rapid, substantial, repairs when they wear or break. In order to be prepared he must study and read his trade papers, books, circulars—anything pertaining to the subject. Of course, this is not the only way but it is probably the best way open to all since everyone can not work under instructors on all makes of tractors. And of course a certain amount of practice (actual work) is needed. But if the repair man knows in advance a fair amount of theory he can readily assimilate the knowledge gained by practice.

The tractor business is now a tremendous institution but is only in its infancy compared to what it will be in the next few years. It is stated by some authorities that it will almost equal the automobile business and everyone is familiar with what that is, in the line of repair work. And it requires no great stretch of imagination to realize the amount of repairing to be done on tractors as soon as the business reaches the proportions to which it is bound to grow.

All running machinery will wear and break in spite of good care; this is a gentle hint to the blacksmith to get ready to repair the tractors. Put the horseshoeing tools aside for the tractors will surely replace "old Dobbin". Perhaps not entirely but to an enormous extent.

It is in irrefutable fact that the oxyacetylene welder is the one who can make repairs that can be made in no other way besides welding. He is the man who will have to do most of the repairing. With a good welding outfit the blacksmith is prepared to do the work probably better than other mechanics because of his experience with hot metals. Given a good welding plant he is fixed to do cutting,

punching, straightening, putting together, building up worn places, and various other kinds of work in the field of oxyacetylene methods. The welding plant is a complete repair shop in itself.

Repairing tractors by welding is but little different from other classes of welding. It is about the same as auto welding except that the parts are usually heavier and in some instances more complex, requiring a little better judgment in controlling expansion and contract-

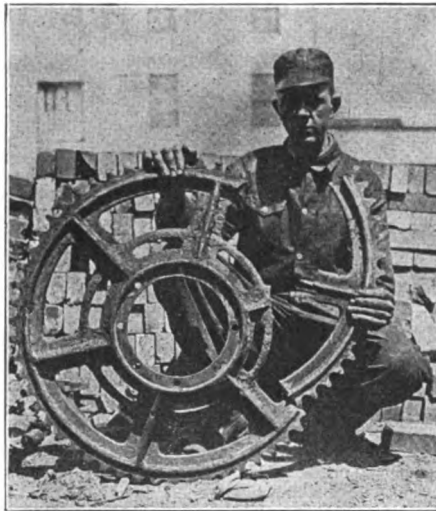

NO. 1 — THE BROKEN TRACTOR SPROCKET WHEEL AS IT CAME TO THE SHOP

tion which are the worst enemies a welder has.

It is manifestly impossible to deal with everything pertaining to tractor welding in an article of this nature so let us select a job likely to come to any shop and see how it was done in one case. First we will suppose the reader to be familiar with the fundamentals of welding and the operation of the different parts.

We will take the process of welding a step at a time from the arrival of the job at the shop until it was ready to return to service. This job, as illustrated in the accompanying cuts was a large sprocket wheel from a chain driven farm tractor, broken as shown in picture No. 1. The breaking in this instance made three welds necessary and offered quite a problem in expansion and contraction, with

one break located in a spoke and two in the rim. To an experienced welder it is plain that the greatest difficulty in welding this casting rested in keeping the rim true, that is, the main problem was to weld the wheel so it would be round when finished. This was done by a clever system of preheating together with a thoroughly studied method of clamping. The actual welding is nothing compared to being able to control expansion and contraction on this and similar jobs. However the welder was careful to endeavor to produce a soft weld because the weld was liable to break again under strain of service if the weld was hard and brittle.

Tractor welding is usually rush work, it must be done as soon as possible. And time will be saved in the long run by preparing the casting for welding before lighting the torch. Every bit of necessary preparation facilitates the welding. This sprocket job was made ready to weld by first burning and scraping away the grease and dirt in the vicinity of all three welds. This for the purpose of preventing any foreign matter from being absorbed by the melting weld. Next the broken sections of the rim were taken to an emery grinder where the edges of the fractures were beveled back an inch from the line of the break. The ends of the rim on the wheel were also ground back a like amount. The spoke fracture was also beveled, partly with a chisel and partly by grinding. This beveling of the fractures formed a "V" groove in each one when the section was fitted in place. The beveling was all done on the top side of the wheel except that of the spoke. It was necessary to make a "V" groove on the lower side of the spoke also. This double groove on the spoke formed two V's which met in the middle of the fracture, necessitating the turning of the casting during the welding. In other words, part of the job had to be welded on both sides.

In the grooving process care was taken to leave small projections by which the rim sections was fitted accurately in place. Had the entire surface of the fractures been ground away it would have been difficult to secure a proper alignment of the rim.

For the benefit of beginners a few words on grooving may not be out of place here. On the average run of jobs like this it is best to

groove the line of fracture to the full depth of the metal from one side only if the shape of the job permits. This avoids the need of turning the job during the welding, a proceeding which often results



NO. 2—WELDING POSITION AND LOCATION OF PREHEATING TORCH

a warped or cracked casting. There is also risk of loosening the clamping devices causing the parts to shift unnoticed by the torch operator with the results of a misaligned casting.

The reason for grooving to the bottom of the crack is two fold: it permits the welder to weld the entire thickness of the metal and it permits the weld being made easier with greater dispatch. The sloping sides of the groove are melted down gradually with little danger of clogging the weld with metal that is only partly fused. Usually the width of the groove at the top equals the depth. A narrower groove is more difficult to weld properly thus, often resulting in a weak joint. A groove too wide gives too much surface which also tends to a weak weld. Of course this ratio of width and thickness doesn't always hold on all heavy, thick jobs wherein it is regulated some by the capacity of the torch. However on nearly all all tractor jobs it is a good rule to follow.

Reverting again to the sprocket job. After the breaks were grooved the next step was to preheat the casting. An air pressure kerosene burner was employed to do this heating. But before lighting the burners the casting was leveled up on the floor and the rim section clamped tightly in place as shown in two of the photographs. The clamps were arranged so the broken piece would slip neither in, out, up nor down. The idea being to make the casting as near like an unbroken one as possible, which made the governing of expansion easier. Two large malleable clamps were used to hold the rim in place

and two small clevis clamps were used to prevent side shift. The arrangement of the clamps is clearly shown in picture No. 4. Picture No. 2 shows the wheel leveled before attaching the clamps. It also shows the position of the oil burner for the first spoke weld. Here the burner was arranged to spread the flame over an area about a foot in diameter around the spoke break.

After the job was clamped the single burner was lighted and allowed to burn until the area became red hot. As the heat increased the section of the rim containing the broken spoke expanded and pushed outward thus throwing a section of the inner flange a fraction out of round. At this stage the first spoke weld was made. Across the spoke and up the brace. As soon as this was done the casting was inverted and the other half of the spoke weld quickly fin-

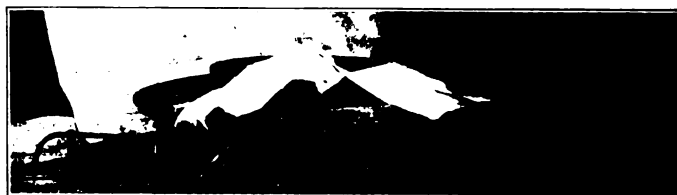

NO. 3—POSITION OF THE BURNERS FOR PREHEATING THE RIM OF WHEEL

ished. The two burners were placed as shown in picture No. 3. These burners were arranged to heat a part of the wheel including the broken spoke and a spoke adjacent to one of the rim fractures. The heat expanded both of these spokes pushing the rim section break out from its center. This area of the rim spokes and center flange was heated red hot before applying the welding flame to the first rim weld. When this weld was started the rim was apparently slightly out of round. This was for the purpose of causing the heated area to contract at one time when the rim weld cooled.

Upon completion of the first rim weld the oil burners were shifted around the wheel until they covered an area composed of the broken spoke and the spoke next the other rim weld. As soon as this area was red hot the second rim weld was made. The shifting of the preheating was to cause the wheel to push, or expand, outward in the general direction of the second weld, so that the whole thing could contract in unison with the weld, thus preventing a strain.

To put the process of preheating in other words we will say that a third or a little more of the wheel was heated by the burners for each rim weld. Which caused that side of the wheel to bulge outward permitting the whole thing to draw inward when the weld cooled. Had the casting remained stationary, so to speak, while the weld cooled and contracted, the weld would probably have pulled away from the casting.

During the process of preheating strips of asbestos paper were spread over the heating sections to help confine the heat and thereby hastening the work. On some jobs it is necessary to cover the casting with asbestos paper to prevent the cold air from causing premature contraction but on this tractor job it was merely to conserve the heat and to protect the torch operator. The casting might well have been welded without covering so far as danger of cracking was concerned unless there were cold blasts of air blowing directly upon the job.

The actual fusing of the fractures was accomplished as follows: First the groove on each side of the wide spoke brace was melted together along the bottom with metal from the sloping sides of the groove. This layer was made probably a fourth of an inch thick. Then the filler was employed to fill the balance of each side a layer at a time along

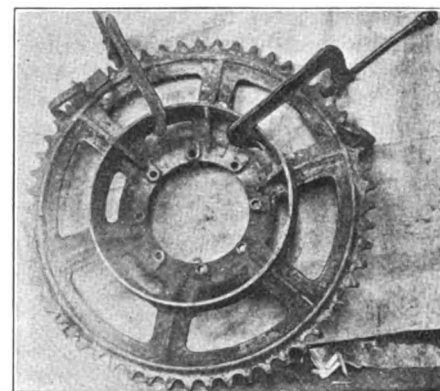

NO. 4—THE WELDED WHEEL AND CLAMPING ARRANGEMENT USED TO HOLD THE PARTS TOGETHER DURING THE WELDING

the grooves. Layer upon layer was fused in until both grooves were filled. Each layer was carefully mixed and joined on sides and bottom to the preceding layer. The

(Continued to Page 255)

Electricity for the House, Shop and Farm

J. L. HAKY

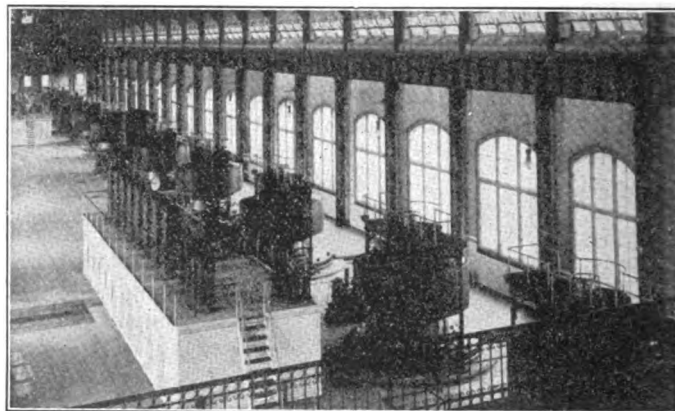

Niagara Falls Power House

KNOWING that many of our readers are interested in the use, application and sale of small electric plants either for their own use or profit, this somewhat general article on the subject is designed to form a better understanding of such plants.

Selling such plants is a line that is being profitably followed by dealers in rural communities and the possibilities have been by no means exhausted, in fact this field is practically undeveloped but the demand is growing and to meet this demand, manufacturers have placed on the market numerous varieties of plants that are designed to meet the tastes and requirements of all.

Many have rigged up their dynamos to water wheels and windmills and the current stored in storage batteries for use when needed. There are numerous advantages and disadvantages to these systems and besides not being always available and so it follows that practically all "farm electric plants", as they are generally called are driven by various kinds of internal combustion engines, using gasoline, kerosene, alcohol, or gas as fuel. Where water power is available it is to be preferred on account of its cheapness and the lack of attention required.

These small gasoline engine driven electric installations are divided into two classes—Standard Voltage and Storage Battery sets, both of which have their advantages for particular requirements.

The standard voltage plant in which the engine and dynamo are usually mounted on the same base, must be kept running whenever current is required for any purpose. Usually these sets are designed to produce 110 volts and

with them all standard types of electric irons, heaters, motors and appliances may be used and since the current is drawn directly from the generator it is important that the engine must be of a most efficient and smooth running type.

In an installation using a storage battery set, the dynamo and engine may be, and frequently are, placed on separate bases and again there are a number of self contained, direct coupled sets on the market that are entirely automatic or semi automatic in their action and control. In sets of this character the dynamo is only operated for a few hours daily and the current is stored in storage batteries and since the current in this case is drawn from the batteries instead of directly from the generator it is

not so necessary that the engine be of the same efficiency as demanded by the standard voltage set. Storage battery sets are usually designed to produce 30-40 volts and indeed this is considered the standard for an installation of this character.

The necessity for great care in the selection of an engine to drive the generator that supplies current direct comes from the fact that any variation in the operation of the engine would cause the lights to flicker disagreeably and of course, as this is of no importance with the storage battery type this constitutes one of the advantages of the storage battery set—a cheaper engine may be used than would be the case in direct lighting.

Standard voltage sets producing 110 volts can be equipped with

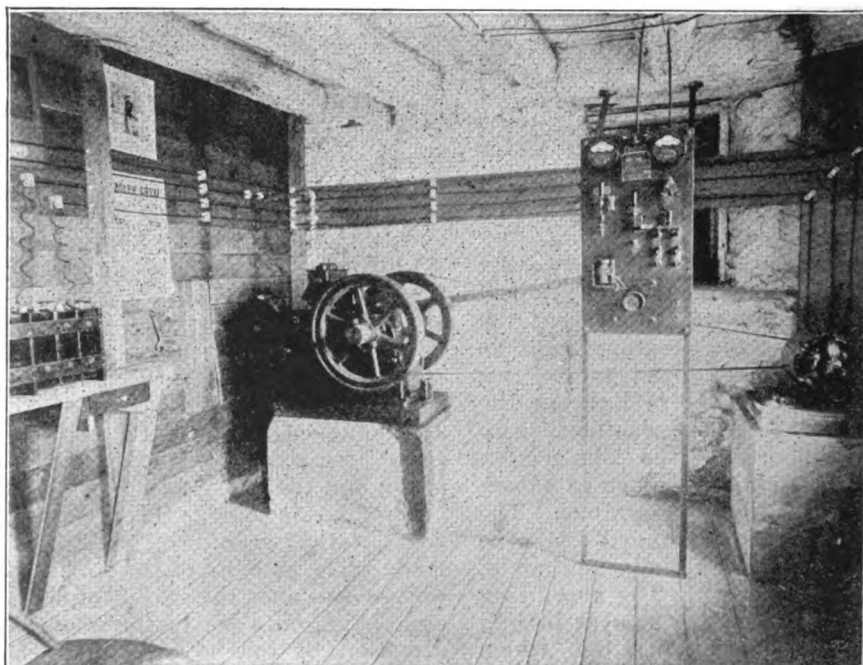

THE LAUSON PLANT SHOWN IN THE ABOVE ILLUSTRATION IS TYPICAL OF MANY SMALL PLANTS. THE GENERATOR IS DRIVEN BY A SEPARATE ENGINE

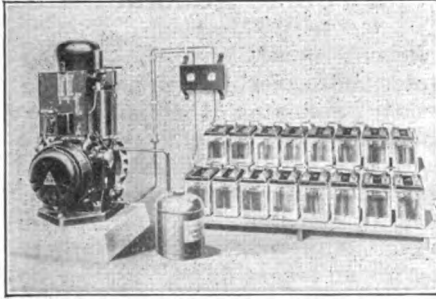

A 3 K. W. PLANT THAT COMES IN 32 OR 110 VOLT SIZES. BATTERIES CAN HARDLY BE USED WITH THE 110 VOLT SYSTEM — TOO MANY ARE NEEDED

storage batteries so that the energy may be stored and the flow will be absolutely even but such a system would require the installation of something between 50 and 60 storage batteries that would prove a heavy item of expense. The smaller storage battery plants are equipped with from 15 to 20 storage batteries, this being necessary on account of the engine generally used to drive such plants.

The automatically regulated type of storage battery set starts the engine as soon as a light is turned on or current drawn for any purpose, an automatic switch turns the dynamo into a starting motor for the engine and as soon as the engine reaches its proper operating speed this switch is cut out and the motor becomes a dynamo again and goes on about its business of generating and storing current. As soon as the last light is turned off the engine automatically comes to a stop.

With a plant such as this and operating at 30 volts it will be necessary that any motor and electri-

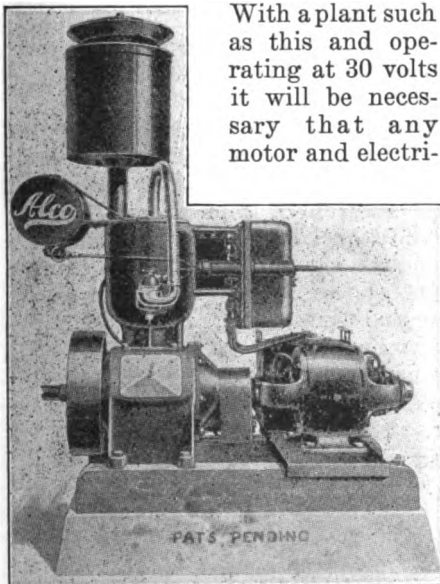

IT OPERATES ONLY WHEN NEEDED. WHEN THE LAST LIGHT IS TURNED OFF IT STOPS OF ITS OWN ACCORD

cal equipment must be wound for this voltage. An electric lamp or other equipment for use on a 110 volt system cannot be used on a 32 volt system and neither can 32 volt apparatus be operated on a 110 volt current.

The storage batteries used are not of the enclosed automobile type that most of us are familiar with but the plates are contained in glass jars and can be readily removed. Also the level of the electrolyte in the cells is always visible.

For small installations, lighting the house or barn or for the average household applications of electricity the 30 volt storage battery type fills the bill admirably and at a minimum of cost. The first cost of such a plant is generally somewhere around \$300, the upkeep for

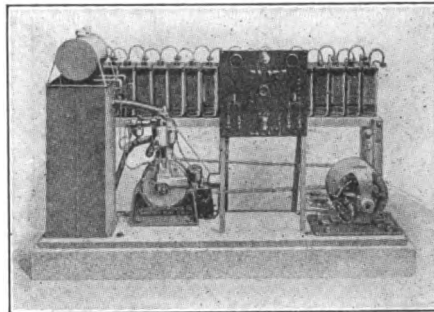

A NON-AUTOMATIC SYSTEM BUT JUST THE THING WHERE A MODERATE AMOUNT OF CURRENT IS NEEDED

fuel, etc., is insignificant, amounting in the majority of cases to about five cents per day.

The number of lights and appliances desired will determine the size of the outfit required. If it is only desired to light up the average sized farmhouse and barn the smaller type will work admirably but if it is desired to use a number of high candlepower lamps at one time and motors and the wires are strung over long distances, the standard voltage set would be not only preferable but necessary. The number of lights that can be used with a storage battery type set can be increased by increasing the storage battery capacity but this is usually undesirable as well as more or less expensive.

The possibilities for the sale and use of such systems in rural communities is great and the only reason they are not more generally used seems to come from the fact

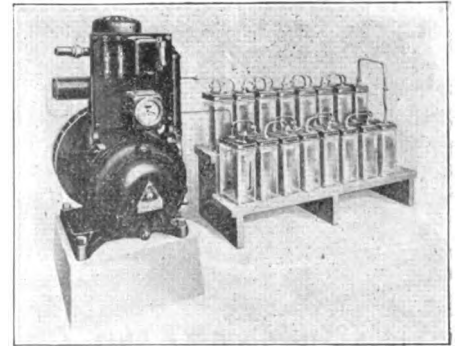

ONE OF THE MOST POPULAR AND LEAST EXPENSIVE SYSTEMS IS THE DELCO

that farmers are not well enough acquainted with the merits of such plants, or from ideas that such installations are expensive, troublesome and complicated which are certainly not the case.

THE MUCH ABUSED AUTOMOBILE TOP

M. H. George

If one were to ask me, what was the most abused part of the automobile, it would be hard to say, but I think that the top gets its share and a little bit more.

Take notice this summer, for we are going to have a summer, and see how many cars that have the top down and no cover over it. Now and then perhaps, you will see the top down and being used as a luggage carrier. Often when the top is down it is used for a rear bumper, the result is bad for the top, and the pocket book.

One thing that the man who sells second hand cars wants to do is to always have the top down when he shows a car for the top seems to hold all the different noises, and there are a lot of them in some cars; right in where the prospective

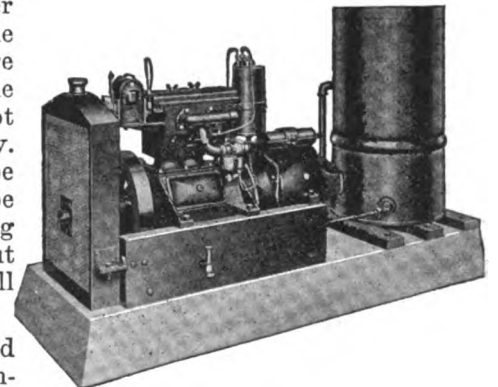

THE MATTHEWS IS ANOTHER AUTOMATIC SYSTEM AND NATURALLY REQUIRES A MINIMUM OF ATTENTION

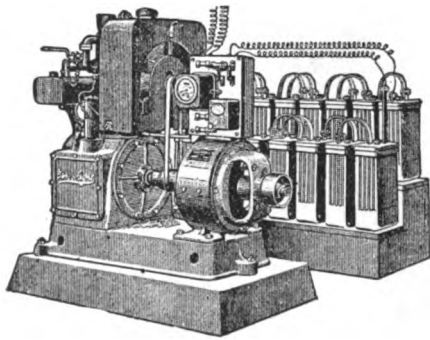

SELF CONTAINED SINGLE UNIT, AUTOMATIC PLANT

buyer can plainly hear them and I have also seen some new cars that would have sold better if the agent had showed them with the top down.

A few years ago most people used to ride with the top down, but now a big percentage of cars that one sees have the tops up.

The only way to keep a top looking nicely is to keep it up, this keeps it smooth and the bows will not wear holes in the top cover. If the top is carried folded and with no cover it soon gets full of dust and the sun seems to fade the lining so that when you do put it up it looks awful.

In going into low buildings one must be careful and not hit the top, for the bows break much easier than they can be mended. I knew of one man who was going to put his car into a shed that had some braces in the door, one on each side, they hit each side of his top and when he heard them start to break, he got excited and opened up the throttle. It cleaned the top off completely and bent his front axle badly.

The top should never be put down and folded when it is the least bit damp as it will cause the material to rot and leak and it will also lose its strength. Sometimes on the road the top will have to be put down when it is damp, but as soon as the end of the journey is reached it should be put up and allowed to dry. In folding a top one should be very careful and not have the top in between the bows as this will chafe holes in the top material. Do not use gasoline on the top to take out dirt stains as this hurts the waterproof part of the top. Soap and water is the best thing to take spots out with. Use plenty of water to get the soap out. The top material known as "pantasote" can be brightened up by wiping it over with a cloth wet in gasoline.

The side curtains need the same treatment as the top to have them last. If the side curtains are to be carried under the seat they should be folded so the celluloid lights will not have bends in them and should come in contact with the curtain material. If two pieces of celluloid are laid together they will rub and scratch up so that one cannot see through them. If your top is one of the kind that carry the side curtain in the top, they should be rolled up carefully and as snugly as possible and fastened firmly in the carrier. The side curtains should be wiped off with a damp cloth before putting away. A good way to clean the outside of a top is to wipe

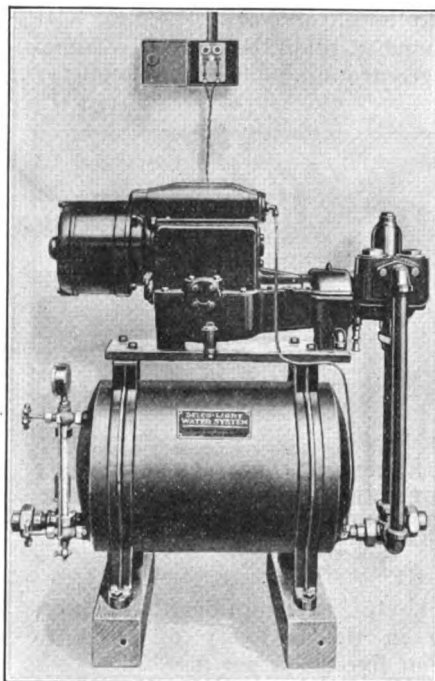

THIS ELECTRIC WATER SYSTEM PUTS ALL THE COMFORTS OF HOME IN THE FARM HOUSE

the dust off with a cloth, it can be damp if needed. The inside should be dusted with a whisk broom. The supports of the top should be kept tight and the straps or whatever holds the back to the body, should be kept tight so that not all of the strain will come on the top material. The joints of the frame should have a few drops of some very light oil put into them once in awhile. All the surplus should be wiped off so that dust will not stick. Sometimes these joints will become rusted and when the top is put down, the bows will break. One should treat a top good for they are nice to keep the sun and rain off and if they have to be replaced, quite expensive.

A PUBLIC NUISANCE

G. W. Morrison

Recently, all over the United States, motor car drivers have been greatly annoying the public by causing a series of loud explosions from their motor cars. Noise making came into vogue during the celebrations and parades incident to the signing of the armistice, but there is no longer any excuse for it.

The sound is similar to the firing of a gun in the streets. In nine cases out of ten, this is purposely done by the driver, who suddenly shuts off his spark and then advances it again.

The next exhaust charge from the engine, being a flame, ignites the gas that was not fired when the spark was shut off, and explodes it inside the muffler, from which the live gas had no time to escape, instead of inside the engine, where the explosion would give power and the noise then be silenced in the muffler.

This usually happens where battery ignition is manipulated by hand. It is not so easy with magneto ignition, as that is fool-proof.

City councils and other law-making bodies should stop this nuisance of sudden explosions, which frighten nervous people, seriously affecting those suffering with mental or heart trouble, and even persons having the strongest nerves.

Many cities are framing ordinances prohibiting unnecessary noises, such as exhaust "cut-outs", blatant horns, clanging bells, shrieking exhaust whistles.

FINISHING LEAF SPRINGS

In finishing off a leaf spring that has been welded care should be taken always to grind off the weld lengthwise and not crosswise. When the spring is hardened and tempered, it takes very little inducement in the shape of a crosswise scratch or fine groove, such as the wheel leaves on the surface, to cause the spring to break off short at the crack. Grind lengthwise and evenly, curving the spring against the stone diameter.

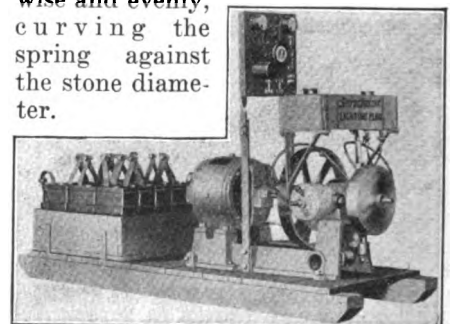

A LIGHT BUT EFFICIENT TYPE

COBALT

Mark Meredith

Cobalt is one of the metals which have come very prominently into notice during the past few years. Researches made by the Canadian department of mines show that it has properties which make it an important factor in the manufacture of certain parts of electrical machinery. Difficulties with the casting of this alloy have not been perfectly overcome up to the present, there being a lack of cohesion which prevented the experimenters from obtaining perfect castings.

The superiority of cobalt to nickel for electro-plating is well known, but the cost of production is too high to permit of its general use.

Perhaps the most interesting aspect of the researches with cobalt, however, is that which deals with the non-corrosive alloys of the metal. Mr. Elwood Haynes gives some details of his experiments with alloys of cobalt, chromium, tungsten and molybdenum, which shows that cobalt-chromium alloys, while they take and hold a good edge, resist the corrosive action of air, moisture, organic acids, antiseptic solutions, etc., perfectly and remain bright permanently. The alloys containing tungsten or molybdenum are so hard that they cannot be forged, but are cast and refinished by grinding. They not only take a fine edge, but hold it at any temperature up to their melting point, a property which makes them suitable in a unique degree for high-speed cutting tools. Some of the facts given regarding these alloys, which have been given the name of stellite, are most remarkable. For instance, a spoon, weighed before and after 12 months use, showed so little weighable loss, that it appeared certain that a thousand years of similar use would not impair its serviceableness.

The principal supplies of cobalt come from Ontario, Canada. Formerly New Caledonia was the chief supplier, but the Canadians, being able to put their cobalt on the market at a lower price, have killed the industry there. A complex ore of cobalt, willyamite, is found at Broken Hill.

The chief sources of the metal commercially are smaltite and cobalite. These minerals belong to the pyrite group, are metallic, with white or grey lustre, but are gener-

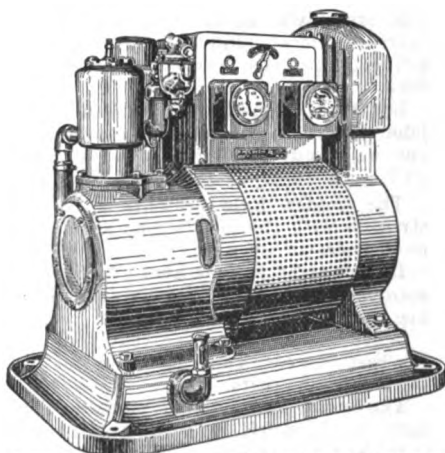

OWEN LIGHTING AND POWER UNIT FOR FARMS AND COUNTRY PLACCS

ally found in conjunction with nickel, iron, etc.

A simple field test for cobalt is by fusing a minute quantity of it in a borax head, which is colored a brilliant blue, both while hot and cold. Impurities which mark this reaction, such as sulphur, iron, nickel, may be removed before-hand by the oxidising flame of the blow-pipe.

THREE HELPS

M. H. George

A car with a broken frame is not a desirable thing, but like lots of other things, they come to us. I have seen a number of such, patched some and helped patch others and have seen them welded, and I believe that I will take the one that is patched every time.

I have run an Overland for eight years that broke on both sides and it has a patch of tire steel three-eighths of an inch thick and three inches wide bolted on with three-eighth cap bolts with spring washers and they have never given any trouble.

I have just repaired a frame and I tried a new kink that I think will work well, you will notice that when a frame breaks it is very hard to close the crack completely when jacking it in place. The reason for this is that the metal stretches before it breaks. On this one I jacked it up in place, or as near as it would come, and then with a hack saw sawed up through the crack, this removed a little of the metal. I jacked it some more and still it did not level up, so run the saw up through again and this time it leveled up all right. This frame was not broken clear through the upper web. This was a three inch

channel and I am going to have the patch in the channel and it will not sag.

A few days ago I had occasion to clean a spark plug and reaching into my pocket to get my knife I found that I did not have it. The spark plug was one of those that cannot be taken apart. I happened to have one of the small files such as used to file the platinum points with, and I found that the handle end made a fine thing to dig the carbon out of the plug with. It worked much better than a knife blade.

On one car that I have had to do quite a lot of work on, there is one place that is next to impossible to grease and it needs to be greased quite often or there is trouble. Between the clutch and the transmission there is a short shaft with a universal on each end. The method of greasing these joints is to turn out a quarter inch screw in this shaft and force in cup grease. The shaft is hollow of course, or that is it has a hole drilled from each end to match the ones where the screws are. Now with the common gun this cannot be done. I took a piece of half inch steel rod and drilled a small hole through it. One end was drilled out so that a common grease cup could be screwed in to it. The hole was threaded of course. The other end was turned down and threaded so that it would screw in to the quarter inch screw hole in the shaft. This piece should be at least three inches long. This piece is screwed in then the cup into this and then one can fill the cup and turn it down and fill it again until the grease comes out around the shaft. Then it can be taken out and the screw replaced.

NEW LICENSE PLAN

By the terms of an act passed by the New York legislature the age of a car becomes an important feature in the cost of registration. This new provision becomes effective on February 1, 1920.

The registration fee will be 25 cents for each engine horse power plus 40 cents for each \$100 of the list price of the car, fully equipped, for the first three years of its life but during the fourth and fifth years this will drop to 20 cents per \$100 of the list price and to ten cents for the sixth year on, the 25 cents per horsepower remaining constant.

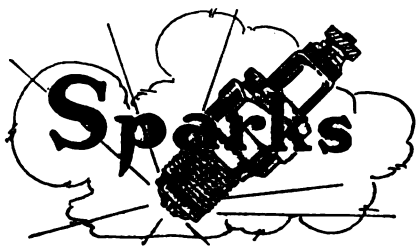

LEAVE 'EM ALONE AND THEY'LL COME HOME

"The boys will soon be back at home
From camps and 'cross the sea,
And we must find them all a job,"
The mayor said to me.
"They'll all be ravin' mad to work;
It'll be hard to hold 'em down—
They'll holler, 'Give us all a job',
The minute they hit town."

"So let us pave a lot of streets,
Dig ditches and build roads;
Let's hand a shovel to each man
As fast as they unload."
Thus the mayor raved and roared—
I thought him off his nut;
I listened patient as I could,
Then answered to the mutt:

"Whatcha think them soldiers are,
Comin' back from the bally war?
Yeh better make no miffs;
Yeh think them boys
Full o' soldier noise
Are goin' to be shovel stiff's?"

"Not on yer pampered corn-fed life!
Just run along and ask yer wife—
She'll know gobs and doughbobs!
She'll tell yeh, 'let them boys alone;
Give 'em a rest; don't stand and moan;
They'll pick their own dear jobs."
—David Baxter.

Nature is a carless cuss. She fixes things so that one girl is wrestling with a perfect 49 trying to get rid of it and another girl is trying to make a perfect 19 look like something.

Why are people so proud of a Family Tree? Trace any family tree back far enough and you will find a wood-chopper.

There isn't much satisfaction in catching a man in a lie when you never believe anything he says anyhow.

Just because a girl is named Olive, don't jump to the conclusion that she is an acquired taste.

When the saloons are all put out of business a new significance will be attached to the old saying that there's no place like home.

In the matter of shoes a woman can wear a size smaller if it comes to a pinch. Slow but sure may be a good motto, but not for the clockmaker.

Now what will become of the Prohibition party, its principal issue having become public property?

It's going to be a long time however, before the suitcase re-establishes itself as above suspicion.

In spite of the fact that we like people to be open and above board, blessings come disguised, while trouble is generally bare-faced.

There is no reason why a municipality should be shabby. Still, there isn't much time to paint the town between now and next July.

Things to worry about—There are no sardines in Sardinia, Ohio.

Every town in the country has its "early settlers". But any blacksmith can tell you that the "early settlers" are all dead.

Let three men empty the same demijohn of whisky and one will want to fight, one will want to sing and the other one will want to cry. Jags is jags.

The Golden Rule presents a constant struggle with the people who have an innate desire to get even.

It's all right to look ahead but many a man has wasted his past by dreaming of his future.

When some people brag that they have the best of every thing they are not talking about manners.

The world loves to be amused, therefore, all the world loves a lover.

If physical exercise came in bottles at a dollar a throw more people would take it.

The man who leads a double life naturally makes the best of his opportunities.

Another fool theory is that a man can't look you in the eye when he is lying to you. The biggest liars we know of can stare you out of countenance even when you have the goods on them and know that they are lying.

It's all right to get in the swim, but in spite of April showers it's still a bit early for duck trousers.

Never judge by appearances. Once in awhile a single man has so much trouble that he looks as miserable as a married man.

Many a man with pronounced ideas mispronounces them.

What has become of the o. f. man who considered the Philadelphia lawyer smarter than the other varieties?

PAST AND PRESENT



—Buffalo Express

Even a clock can take a rest when it is all run down in the spring.

It may seem paradoxical. But the fact is that the higher you rise the less chance you have of being above suspicion.

The fellow who sings his own praise is about as melodious as a hen cackling over her last egg.

Prof. Covaleski has spent 20 years of his life writing a book to prove that certain historic personages were lunatics. And still no recipe for taking the shine off trouser seats.

"Water washes away 3,000 souls" was a recent headline in the papers. An evangelist would probably take exception to that.

True, this may be a dull season in theatricals but as Kin Hubbard says: "We still have the hosiery windows with us."

There are cures for 70 per cent of the diseases to which mankind is susceptible, yet there is nothing to prevent a shirt crawling up in the back.

About the lowest down trick ever played on any man was played on the late James Dobbin, of Michigan, whom another hunter mistook for a squirrel.

You may not believe it but most of the nuts are raised in cities where there are no trees. A crowd of people has been standing in front of a Buffalo store for three weeks watching for a clothing store dummy to show signs of life.

Some people go to extremes. Occasionally you meet a man who has a level head and is also flat-footed.

- It is not always easy
- To apologize,
 - To begin over,
 - To admit error,
 - To be unselfish,
 - To take advice,
 - To be charitable,
 - To be considerate,
 - To keep on trying,
 - To think and then act,
 - To profit by mistakes,
 - To forgive and forget,
 - To shoulder a deserved blame,
 - BUT IT ALWAYS PAYS.

You never can tell. Many a girl who just dotes on spring lamb will marry a blacksheep.

FROM DAN TO BEERSHEBA
COOK—All around; \$60 per month.—Ad in Chicago Tribune

WE BLUSH!
Our new 1919 underwear has arrived. Come in and look us over.—Ad. in Mercyville, Ia., Banner.

A FRANK CONFESSION
WANTED—A designer wants a woman partner with \$10,000 for a good enterprise.—Adlet in Chicago Tribune.

WE'LL WAIT TILL YOU GET THE REST ON
We are ready for you in underwear hosiery and mittens.—Ad. in Sarnia, Can., Observer.

THE EFFICACY OF PHYSICAL CULTURE
FOR SALE—A physical culture restaurant and institute. Reason for selling, ill health.—Ad in Chicago Tribune.

THIS GUY'S HUNTING TROUBLE
WANTED—Successful writer, westerner, is unmarried. Would like to hear from buoyant-hearted young women of trim build with a little of the rebel in them, a love of books and new horizons, and enough of the actor to be able to adapt themselves to varying circumstances.—Ad in the Masses.

ARE YOU A "SUCKER"?

Have you bought any stock in oil companies, gold, silver or copper mines, automobile stock, stock in tire or rubber companies, or are you a stockholder in some lead zinc, copper or asbestos enterprise?

You can buy stock in such propositions for from a cent a share up but unless your tastes run to green and gold effects and you want the attractively engraved stock certificates for wall-paper we wouldn't recommend buying any.

If a man or a concern has anything worth while it won't be necessary to peddle his stock from house to house. Neither will they sell it because of their love of letting the "common people" or any one else in on "something good."

There are all sorts of schemes for relieving the gullible of their money and once gone it is gone for good. You will doubtless be told how much John N. Willeys made in the automobile business or how much was made from a share of Bell telephone stock and other similar instances but if anybody tries to sell you any stock in rotary motors or anything else that you know nothing about tell the philanthropic salesman to be on his way.

The automobile industry and the tire and rubber business has been organized on such a basis that there is no possibility of any new companies making very much money in these fields, and certainly not as automobile companies were making money some years back when the industry began to expand.

The oil business is much the same and if there is anything good to be had there are only a few who can possibly get in on the money—the people who own the property and the man who sells you the stock in some oil company that only technically exists.

Money is not and cannot be made in dabbling in such stocks by anyone but the seller. True, the professional stock gambler will make a "killing" now and then by playing the markets but such cases are rather exceptional.

If you have any money that you want to invest and know that it is safe and that you will get a fair return on the investment "soak" your money in Thrift Stamps or Liberty Bonds, or if you feel that you must buy stock in some enterprise—don't, for the love of Mike, do it before you consult your banker and get his opinion on its possible value.

The Late Phineas T. Barnum of circus fame laid much of his success to the fact that "there is a sucker born every minute". Fake and other doubtful stock propositions are prosperous or not depending altogether on the crop of "suckers". Are you a "sucker."

GARAGE DISCONTINUES REPAIR DEPARTMENT

More and more the automobile repair business is being forced on to the blacksmith as witness the following clipping from the Fort Worth, Texas Telegram.

"Owing to the fact that it is impossible to obtain first class mechanics, the Modern Garage has decided to close down its mechanical department and in the future they will only take light repair and adjustment jobs. In the future nothing in the way of heavy repair jobs will be attempted."

HOW TO PROTECT FINISH OF AUTO

Proper washing and polishing of a car may look like a simple matter, requiring little or no attention. In reality the most beautiful body finish often is ruined within a short time by neglect of a few simple precautions.

The finish of some cars requires as many as twenty-nine separate operations. The early priming coats are put on by means of compressed air, which forces the special material used into every crevice and interstice, giving a splendid foundation for future coats. Numerous coats are, of course, still put on by hand and brush in the old-fashioned way.

After each coat of finish the bodies go into ovens where the finish is baked on. On coming out of the ovens, each body is rubbed down by hand. The result is a finish brilliant and durable, almost impervious to weather, washing, rubbing and mud. But at the same time the finest finish may easily be scratched by bits of road grit.

Therefore care should be taken not to rub the dust off the body with a dry cloth. When it is desired to clean the car a stream of water should be used first. Care must be taken to prevent too forceful flow of the water as this will drive the grit into the finish. After the body is thoroughly washed down, it should be gone over with a soft sponge soaked in water.

By doing this the car will retain its brilliance of finish almost indefinitely.

AUTOISTS 'DIG OWN GRAVES'

Just remembering that the slower a wheel turns the more traction it has, will enable many motorists to avoid the terrors of a self dug grave when stuck in mud or sand.

Nine owners out of ten, when stuck in the mud will put their cars in low gear and race their engines for dear life, shortening the life of both tire and motor. With wheels going at such a pace it is impossible to get any traction, even if straw or twigs are placed beneath the treads, and tire chains will be slipped around idly. The effect is usually to dig a deep hole and increase the difficulty.

The correct way is to pack cloth or twigs beneath the wheels, use low gear and only speed the motor sufficiently to take the clutch without stalling. Above all things don't race the engine.



Bicycle Rim Cement—A good thick shellac varnish, with which a small amount of castor oil has been mixed will be found a very excellent rim cement. The formula recommended is, shellac 1 pound; alcohol 1 pint; mix and then dissolve, then add castor oil ½ ounce. The castor oil prevents the cement from becoming brittle and hard.

A compound that is said to be especially good for plow share work can be made by adding to every pound of pulverized borax, four ounces of dry venetian red paint (or any colored dry mineral paint). You can turn the edge of the lap and put some of this on it and weld it up making a good, solid edge.

Of course it goes without saying that your fire must be clean and free from sulphur as possible.

Cast Iron Brazing—Nearly everyone has had at one time or another a broken piece of cast iron to repair, which owing to its shape, etc., required either arduous patching or had to be sent to one of the companies who make a specialty of this kind of work. By using the following brazing process considerable expense and delay can be avoided. The pieces of iron are first prepared for brazing as if they were of steel, but instead of borax the following flux is used: 4 oz. carbonate of iron, 1-3 oz. potassic chlorate, 1 oz. carbonate of iron. Can be procured at any drug store and costs about 25 cents. Get the iron as hot as possible and use the above in conjunction with brass or spelter exactly as for steel. The process has been used for a long while for repairing sewing machine parts in a large factory, and has always proved satisfactory.

To Write on Steel—Stamping tools with steel stamps will spring them and throw them out of true. Machinists should write their names on their steel tools using a fluid made of nitric acid 1 part, water 2 parts. Heat the tool gently until some wax that has been put on it melts and spreads thinly over the surface. When cold blacken the wax at a candle; then write on the wax with a steel point deep enough to touch the metal, and cover the writing with the fluid. In about three minutes wash and remove the wax. This fluid, however, will spread more or less and the writing will not be very fine. A better fluid can be made thus: Alcohol 2 parts, nitric acid 1 part, distilled water 15 parts, and nitrate of silver ½ drach per quart of fluid. Nitric acid, however, produces vapors that are disagreeable and harmful. Chromic acid made by dissolving one part of bichromate of potash in 5 parts of sulphuric acid, for this reason is more desirable as an etching fluid, although much slower in its action.

Black Oxide Coat for Steel—A fine black coat is produced on steel if treated in the following manner: An oxidized skin is first produced in some suitable manner on the surface of the steel; this is converted into black oxide by means of hot water and continued until the coat of oxide is thick enough. Then the articles are dipped in lukewarm water to remove any acid or salty particles, and then some olive oil is poured over the whole.



The Horseless Age Be
But It

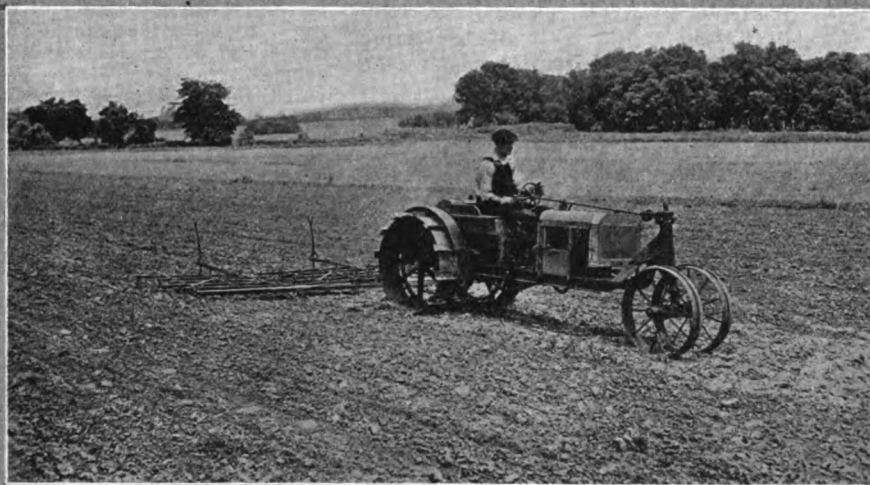



Not Be Here—
ning.

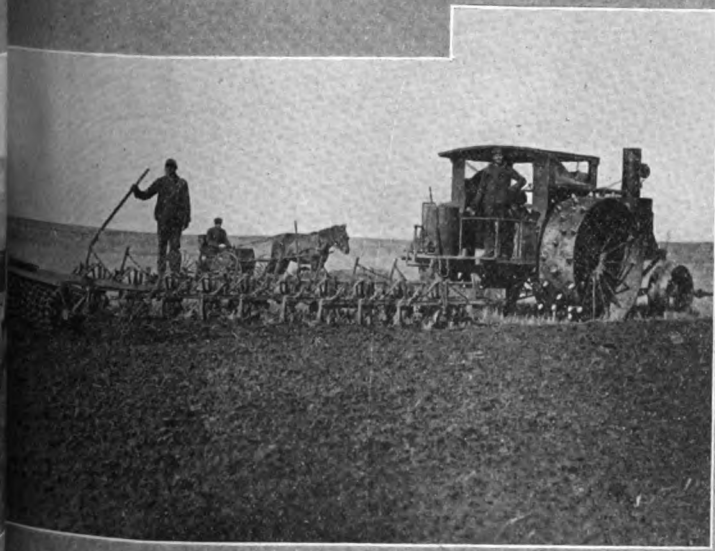
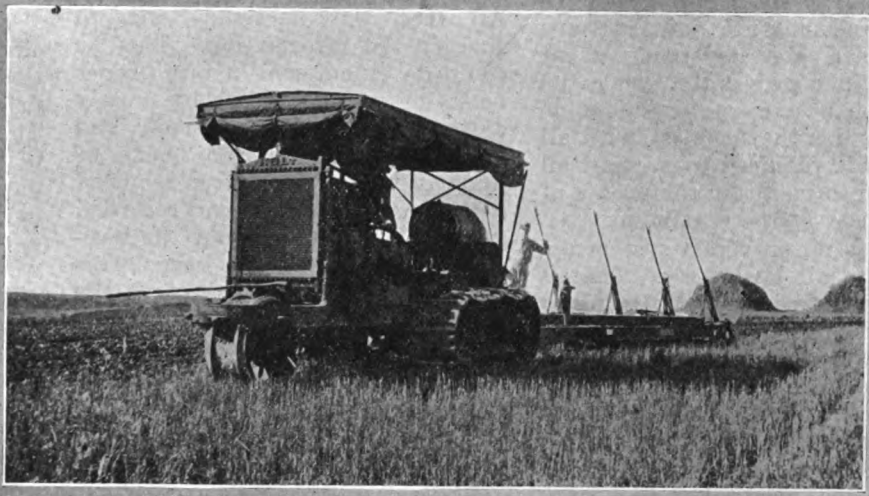
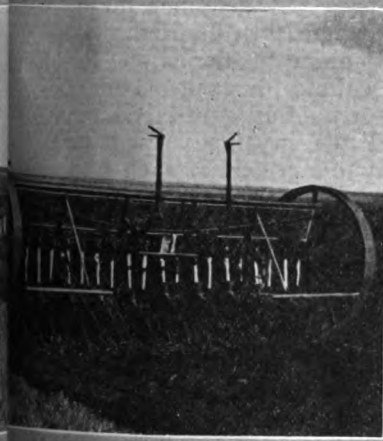

Keeping Track of the Business

ROBERT FALCONER

THE word "accounting" is long and mysterious looking and is used by the clergy in connection with our sins. They tell us that the wicked will one day have to make an accounting for their evil doing. Bookkeeping is another word that has unpleasant relations. It pictures in one's mind dusty volumes filled with cramped handwriting, a wizened up little old man wearing a green eye shade and steel rim spectacles and a tall desk at which he is sitting on a high stool.

The object of both accounting and bookkeeping nevertheless is to keep track of the business. High stools, tall desks, wizened up old men, steel rim spectacles, green eye shades, and sins are not necessary to make a good system. That system which proves the best is the one which at the smallest possible cost provides the business with all the records required to prevent all leaks and to maintain the profits of the business at the maximum.

There is no universal system applicable to all businesses. That is probably the reason why so many firms no longer refer to their bookkeeping department but rather to their accounting department. Each business has different problems. There are no two businesses of exactly the same size. This means that the method of keeping track of the business which works out with perfect satisfaction for one business may not prove equally as effective for another. Each man will have to work out a system that will best fit his needs. The system used however is not so important as it is that every man in business keep very close track of his business. In these days of the high cost of doing business and unsettled labor and price conditions it is more than every necessary that every man keep very close track of his business. If he does all will go well. If he does not he is pitching pennies with the sheriff and sooner or later that gentleman will win.

Out on the Pacific Coast there was a man who started a one man shop. He did all the work himself both in the shop and in the store. He however realized the necessity of keeping track of his business. It

was also necessary that the system be as simple as possible.

He purchased a recording machine that made a copy of every entry. On this he attached a bracket upon which he fastened a cheap watch. Every sale, every bit of material used, every minute of time spent in the store or shop he recorded upon this machine. At the end of the day he had a record which showed upon what jobs he had worked and the length of time he had worked upon each job, it showed how much time he had spent in the store and what sales he had made there. It showed how much time he had spent with salesmen. Everything was recorded. All that was necessary was to classify the information. This he could do by entering it into proper books or upon cards or by merely cutting up the original copy and pasting the pieces into books or upon cards. The system required little time, was simple and recorded all the information about the business it was necessary to keep. This man made money from the first. His success was largely due to the fact that he knew to a cent just how much each job was costing him. He could figure closely yet be sure of a profit.

On account of their simplicity and convenience card systems are coming into greater and greater popularity. There is scarcely any system

of keeping track of the business to-day that does not use cards. One very satisfactory use is as follows: The job card is printed on light card stock and also upon two heavy sheets of paper each of a different color. When a job comes in the order is made out in triplicate by means of carbon paper. One copy goes to the shop, one to the stock room and one is held in the office. The stock room sheet is returned with a notation upon it of all material issued for the job. The shop sheet is returned with all the time spent upon the job recorded. In the office these times are totaled, the overhead and profit added and the bill made out.

The card which remains in the office has entered upon it the itemized cost of doing the work and the price charged the customer for it. These cards can then be filed away in heavy manila envelopes one for unpaid accounts for each customer and one for paid accounts. On the outside of the envelope it will be wise to make a record of each card giving the date the job was done, what the job was and the amount. This will guard against the loss of any cards. When the job is paid for it is stamped paid on the card and the card placed in the paid envelope of that customer.

The envelopes serve as a customer's ledger but have the advantage that they contain far more information than could be written into a ledger. At the same time the cost of keeping track of the customer's accounts is reduced to the minimum and the garage man knows just what profit is made on each job. If he has figured his costs accurately the sum of all the job profits will equal his net profits for the year.

The use of the old fashioned day book and ledger has been pretty generally dispensed with in modern business. The recording machine serves every purpose of the day book and has the added advantage that several copies of each entry can be made with no more work than is necessary to make one entry. The original copy may take the form of a bill if the entry is a sale, second copy can go to the office for entry on the customer's account

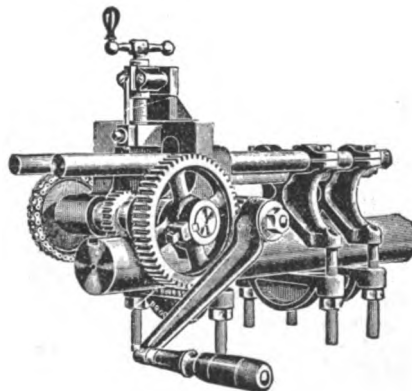

PORTABLE KEYSEATER

An ingenious machine for cutting keyseats on line shaft has made its appearance and with it the millwright is able to cut a keyway up to five inches wide and 12 inches long without removing the shafting.

and the third retained in the machine as a permanent record. This system tends to cut down mistakes and since the customer receives a bill with each purchase, to cut down complaints in regard to the monthly bills.

In the office the customer's charges are posted into a loose leaf ledger arranged in such a way that the original is a customer bill and the copy a permanent ledger record. At the end of the month instead of spending hours in making out bills all that is necessary is to total up each account tear out the bill and mail it. The ledger and the bills being exact duplicates there can be no mistake made on one that is not also made on the other. Bill making and ledger posting being a single operation the time required is cut down at least one half.

At the end of the month it is well to total up the expenses and the income. In doing so class all doubtful accounts as expenses. Do not give up the attempt to collect them but charge them off in the monthly profit and loss sheet as loss. On this sheet only real profits should appear and doubtful accounts are very far from real profits. To make this profit and loss sheet complete and accurate it will be necessary to take an inventory of the stock and

to add or subtract as the case may be the difference in the value of the stock on hand the first of this month and that on hand the first of last month. By following this method the garageman does not have to wait until the end of the year to learn whether or not he is making money.

For keeping customer accounts there are on the market systems which require but one entry for each sale. These take the form of duplicate books with cabinets for keeping the copies in customer accounts. The original copy goes to the customer as a memorandum bill while the duplicate is filed away under his name in the customer file. The previous total is carried from the bottom of the last slip to the top of the next so that the customer has his total with each memorandum bill. When making out bills under this system it is wise to add up the accounts again and not to rely entirely upon the carried over total since mistakes can happen at each sale and the carried over total be too high or too low.

Large shops require considerably more complicated systems than small ones. In the large shops all original entries are usually made on recording machines. The rolls in these machines are usually

printed in forms with each form numbered and each form must be accounted for. This aids the office in keeping accurate track of every transaction. It is usually necessary to make more copies of each order in the large shop. For example if parts or material is issued from the stock room, one copy may go to the shop, one to the bookkeeper, one to the inventory department and one be held in the stock room.

In a large shop it is usually most convenient to keep the inventory on cards, the original entries of sales, parts, material, etc., on recording machines, the job records on cards and the customer accounts on loose leaf ledgers similar to the one already described. If the shop is very large and the amount of business transacted great the posting of the customer accounts may be done by a machine which works very much like a typewriter and makes as many copies as desired in one operation.

The use of machinery in keeping track of the business has cut down the amount of work and time required as much as the automobile has cut down the work and time required to go from one village to another. In adopting a system, however, and in using machinery

(Continued on Page 254)



THEY STILL DO THINGS LIKE GRAN'PA DID IN THE HOLY LAND, IN FACT THEY EVEN GO BACK TO THE TIME OF ABRAHAM

RADIATOR SHIELD

In wintry blasts get under the hood of an automobile, hard starting is only the least of the motorist's troubles, and while pieces of carboard, old carpet and other ar-

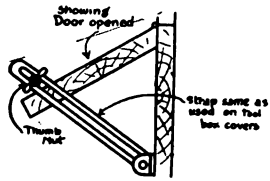
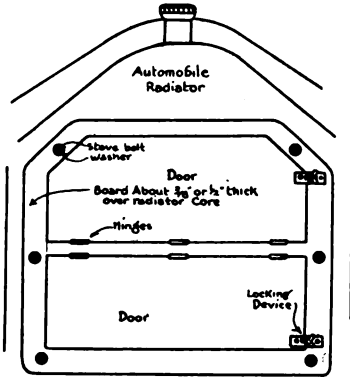

RADIATOR SHIELD

rangements are used to keep cold air from entering the radiator they are generally recognized as unsatisfactory.

The illustration accompanying shows a substantial and satisfactory arrangement that is permanently attached to the radiator for the winter by means of stove bolts through the radiator core. The two doors are hinged and are provided with the same kind of stops that are used on tool box lids and desks. The cover may be made of 3/8 or half inch lumber or sheet metal and can be painted to harmonize with the rest of the car.

CASE-HARDENING

This is a substitute for tempering, and is used on metals that cannot be tempered or hardened in any other way. There are several ways and means of doing this work, and I will give only one or two of the best: Heat your article to be case-hardened to a bright red; sprinkle over powdered rosin till thoroughly coated and plunge into clear water. This works fine on any wrought iron work. For cast iron use prussiated potash or common lye, or even the muriate of potash is good. Use same method as with wrought iron.

PIPEFITTER'S BENCH

The illustration clearly shows the construction of a portable pipe fitter's bench that is built of pipe and

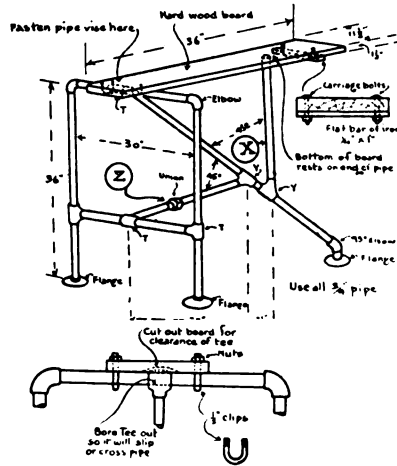

PIPEFITTER'S BENCH

fittings. When it is desired to transport the bench from one job to another or store it away with the occupation of minimum space, the union at "Z" is unscrewed and the pipe at "X" is turned to one side.

HOISTING TACKLE

In shops where there are steel beams overhead it is possible to devise simple attachments that can be applied to the beams from heavy hoisting. The illustrations show a few devices of this character that

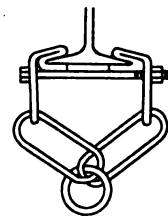
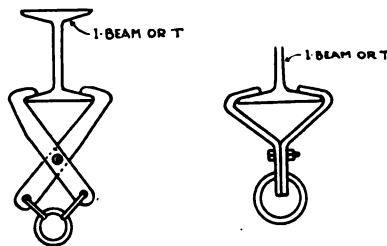

HOISTING TACKLE

are made of 1/2 inch stock. When the beams extend in the proper direction in relation to the work a trolley hoist can be fitted to the beams at small expense and the hoisting arrangements is always handy when wanted.

KEEPING OIL FROM SHAFTING

Oil that runs along the shafting and drips to the floor is not only a nuisance but requires additional

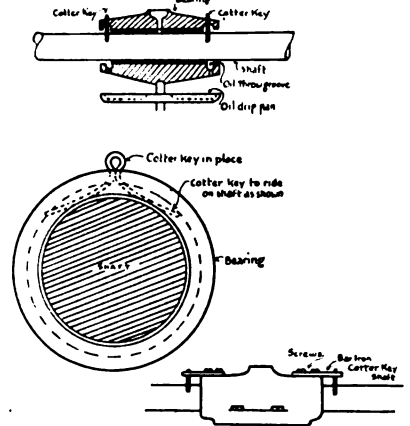

KEEPING OIL FROM SHAFTING

labor to keep the shaft bearings oiled and the floors cleaned up. The accompanying illustrations show how, with the use of a few cotter pins the oil is kept from traveling along the shaft.

REMOVING JAMMED SCREWS FROM TOOLPOSTS

The usual way to remove a jammed screw from a toolpost is to anneal the screw and drill it out. This process causes the loss of much time. A quicker way of doing this job is as follows: make up a square punch a little thinner than the width of the slot in the toolpost.

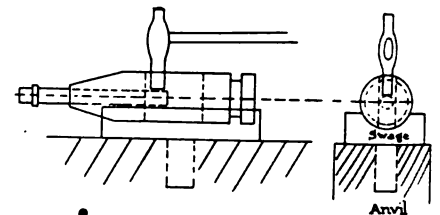

REMOVING DEFECTIVE TOOL POST SCREWS

Put the toolpost on a bottom swage on the anvil. The screw should be turned so it is about half an inch into the slot. Now the punch is set on the screw close up to the shoulder. Then the punch is hit with a sledge hammer and the screw sheared off. This method has worked fine and has saved much time. R. M. Peterson.

USEFUL LINER KINK

It sometimes happens that we find ourselves short of just the right kind of stock to do a job with and we resort to using some discarded part of a machine to work over into the piece needed. Many

tight places have been gotten out of by the use of such ideas, and one that I have used several times seems worthy of passing along to the boys. The sketch shows how (when I found myself short of 1/8-in. flat brass) I split open some

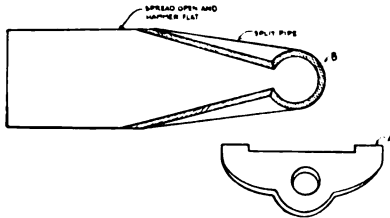

BEARING LINERS MADE FROM BRASS TUBE

brass pipe, flattened it out smooth and made some liners that I needed for a babbitting job on some engine crank bearings. Keep this idea in mind, for many sizes of sheet brass can be obtained from pipe and tubing that comes mighty handy for clips, brackets, etc. It is a good way to use up short ends of tube and pipe.

UNIQUE WIRE BRUSHES

For all around usefulness, these durable, cheap, wire cleaning brushes made from short pieces of worn out hoisting cable are hard to beat. We made up several of each kind shown in the sketches and use them to clean out the chips and turnings that accumulate in the slots of the planer, lathe, etc., and for getting into corners where a corn brush would be broken down if used.

The one shown in Fig. 1 is made by bending the cable around so that two parts can be wired together. These wires are then soldered, then the ends of each strand of the cable are separated or teased out into the fan shape. The type shown in Fig. 2 is made from pieces of pipe. Short pieces of cable are put into the pipe and then the end of the pipe is smashed down onto them

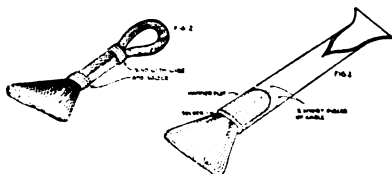

EASILY MADE WIRE SCRATCH BRUSHES

with a hammer. Then a small amount of solder is put on as indicated, to secure them. The cable strands are untwisted and separated to make the brush. The other end of the pipe is opened and flattened and made into a small dirt scraper, as indicated at A.

BELT AND GASKET PUNCHES AND KEY KINK

Here is an easy scheme for making any small size of belt or gasket punches. The sketches tell the

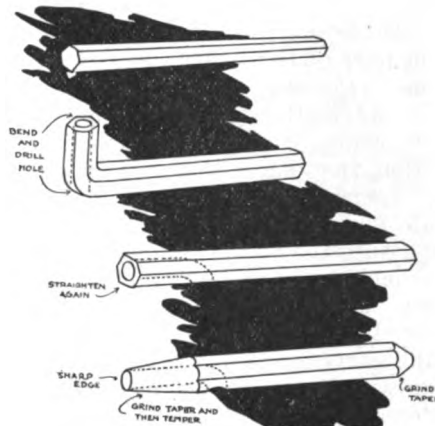

PROGRESSIVE STEPS IN THE MAKING OF A SMALL LEATHER PUNCH

story. It should be said that the bending should be done by holding the end of the piece in a vise, for hammering the bend will be liable to close the hole.

There is often a need to make a

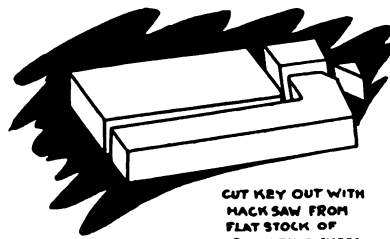

CUT KEY OUT WITH HACK SAW FROM FLAT STOCK OF RIGHT THICKNESS

key quickly and if one has the stock there is no quicker way than that shown in Fig. 2. The stock should be of the size key wanted, then there is no fitting to be done by filing.

HANDY USES FOR SHORT ENDS OF RAIL

These sketches show a couple of handy bench and vise tools made from short ends of rails; they are easy to make and will pay any busy shop to add to their equipment.

To make the vise anvil shown in Fig. 1, the lower edge of the rail is simply drilled and cut off as indicated in Fig. 2. It has been a very noticeable trait among many shop men to abuse a bench vise by hammering work on the jaws when the vise is closed. If a handy shelf is provided underneath the bench near the vise and one of these vise anvils kept ready there, it will prevent such abuse.

Fig. 3 shows a very excellent bench stake that requires only a small outlay of time to make. The lower end of half the length of the stake is cut as indicated and the rest of the foot of the rail makes a base by which it is clamped to the

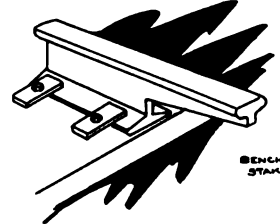
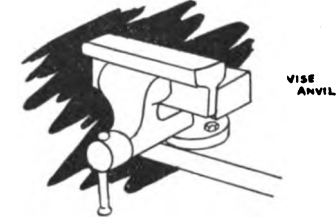
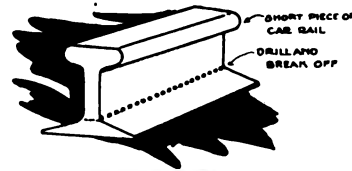

A FEW USES FOR SHORT PIECES OF STEEL RAIL

bench by small straps. Other handy devices can be made of an old rail. We purchased one old rail from the local car company and cut it up for these two uses, and made a bending press with the rest.

BELT TRIMMING TOOL

Quite often I have had customers bring in machines for overhaul and supplied them with new belts to replace old crimped edge ones. Having a need of a device to trim the edges of these old belts I rigged up the device shown in the sketch. I

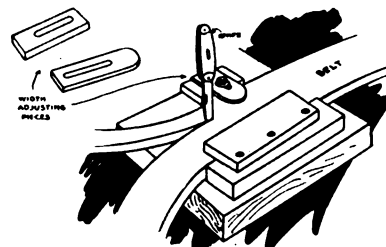

BELT TRIMMING TOOL

use it to cut belt lacings and split wide belts into two narrow ones. The affair is simple and constructed of boards, and a flat piece of iron which is used as a guide and width gauge. A jack knife with its point stuck in tight supplies the cutting tool.

KEEPING TRACK OF THE BUSINESS

(Continued from Page 251)

for keeping track of a business it is necessary to use sound common sense. If you have a flivver business don't use a Packard system and if your accounting machinery requirements are of the motor cycle size don't buy and use machinery that will meet five ton truck requirements. Some system of keeping track of your business is required but be sure that the system fits your business and not somebody else's. Some sort of machinery will very greatly cut down the cost of keeping track of the business but be sure that the machinery used fits your requirements and not those of some big city branch of a great manufacturer.

"ASSEMBLED" AUTOMOBILES

J. L. Haky

About every once in awhile, or oftener, we hear some automobile "authority" brand some make of automobile as an "assembled" car. This is supposed to make anyone lose his enthusiasm over that particular car with promptness and despatch, but why?

An "assembled" car is a car that has its front axle made in Detroit, its engine in Wisconsin, its radiator in New York, its wheels in Missouri, and so on. All of these parts are assembled by the maker who gives his name to the car.

It hasn't been so many years ago when the utmost condemnation that could be heaped upon an automobile was to call it an "assembled" car when, as a matter of fact there were fewer assembled cars than there are at the present time, simply because the industry had not reached that stage of standardization that the industry now knows and therefore individual builders were compelled to do more of the actual work on the parts of their cars than they now do.

As an example, would anyone question the quality of a car that had in it a Continental or Buda engine, a Gray and Davis or Westinghouse electrical equipment, axles and forgings made by the Bethlehem Steel Co., a Timken rear axle a Brown-Lipe transmission, a Fedders radiator or a frame made by the Savage Arms Co.? This is exactly what is happening every day of the year. The manufacturer, if he is financially unable to install all the machinery to build his

own engines and machine his own parts sends his blueprints and specifications to various manufacturers, who make a specialty in some line, and from them he receives the parts all accurately machined and ready to be installed, with the guarantee of the maker behind each part. Do we hear any objections to this way of doing things?

To draw the line still farther, how many cars can escape the dictum that such and such a car is "assembled"? The companies that manufacture all parts that enter into the operating mechanism of their cars are few and far between and while some companies control or own the concerns that make parts for them the case is the same and if it were not for this fact automobiles would cost considerably more than they do and they would not be as good as they are.

So, before you let anyone try to tell you that an "assembled" car is no good just think a few thunks and tell the wise-guy to go run up a rope that this is your busy day.

DRILLING HARD CAST IRON

David Baxter

THERE are several ways of softening hard cast iron in a weld so it can be drilled or filed. Or, perhaps, I should say, there are several methods of attempting to do it for while some of it will soften, all of it will not succumb to any of the following suggestions.

For the first method; if the casting is small enough it is heated all over in a slow charcoal fire until it is cherry red, then covered up with fine charcoal, then covered up with ashes. Bank the ashes over the whole thing so that no air can reach the casting or fire. Allow the casting to cool slowly under the ashes until perfectly cold. Try a second attempt if the first is not enough to soften the casting, before giving up.

If the casting is too large to heat all over then heat an area several inches around the place where it is desired to drill. The heating may be started with the welding torch but the charcoal should be piled upon the spot at the time of heating, and care should be taken to not overheat or melt the iron. When the charcoal is burning good and the area is cherry red cover it with fine charcoal, then with ashes and allow to cool as stated for small jobs. This is probably worth a second attempt too, if the first fails.

Another suggestion is to get the area cherry red with the torch and then bank it in lime instead of charcoal. Use lots of lime and permit it to remain until the spot is cold. This will sometimes do the business but not as often as will the charcoal method.

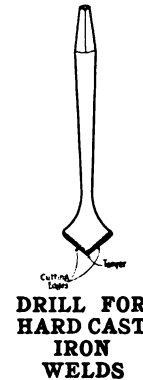

DRILL FOR
HARD CAST
IRON
WELDS

Still another method used with varying success by some welders is the annealing of the casting or spot where the drilling is to be done, in sulphur. The area is first made cherry red then covered deep with sulphur. The sulphur will melt and form a crust over the spot shutting out the air. The job is allowed to get cold before breaking this crust. The sulphur method is probably the least likely to soften the metal. However none of these methods are guaranteed to soften it in all cases.

But there is one method that will succeed if properly executed. That is for the welder to re-melt the weld and scrape or dig out the hard spot with a spatula or a file. Then re-weld it and be careful to not make it a hard weld this time. It is not necessary to have any hard cast iron welds if the torch operator is careful. He should use a soft, high silicon, cast iron rod of proper size for a filler, together with a good flux applied sufficiently. His flame should be regulated correctly neutral and so kept during the welding. He should manipulate the flame so as not to injure the metal. The torch should be fitted with the correct tip for the work in hand. If everything is right there will be no cause to soften the weld so it can be drilled.

In connection with the annealing methods given above the welder should try a specially made and tempered drill. This drill, as shown in the sketch, will be more apt to succeed than the ordinary twist drill. It is made of tool steel and tempered very hard on the point. The idea is to get it harder than the cast iron if possible. I have known of drills made like this from old rake tooth that gave good satisfaction.

In any case the drilling must be done very slowly with light pressure, especially when cutting through the lower scale. The bit is not allowed to get hot. If an ordinary bit is used it should be

ground more blunt and run very slowly under light pressure. Now, while I recommend re-welding the particular spot, the welder ought to succeed with one of the above methods. If the metal can be softened at all one of these annealing processes in connection with the special drill ought to do the work.

WELDING A TRACTOR BULL-GEAR

(Continued from Page 241)

last layer was sloped to a feather edge where it joined the casting. Very little surplus metal was added as this would not add strength to the weld. The pressure of the torch was used to blow the metal smooth and even.

During the welding the filler was kept continually in touch with the melting weld when not applying flux or digging out bits of slag, and continually in motion, twisting over and over to assist in mixing the metals and to loosen and float any bits of slag in the weld. Whenever a bit of dirt or slag appeared it was gradually worked to the edge of the weld where it was blown away with the flame. Flux powder was applied by dipping the melting end of the filler rod in a pot of it, returning it to the weld as quickly as possible. A continuous supply of flux was supplied to the weld. About once to every half inch of the groove. Upon completing the grooves on each side of the spoke brace the welder turned his attention to the brace weld. A novice would probably have to tilt the wheel to bring the brace weld horizontal but it can be welded as this one was by working back and forth across the groove building it up a bit at a time. In effect the filler was piled up a layer at a time until the break was full. As the weld piled up the sides of the brace were kept smooth by scraping away any dribbling metal with a flat file. This was done while the metal was still melting hot, requiring quick change from file to filler and vice versa. A clever welder can employ the filler rod to scrape the weld if he is deft and sure. In connection with the scraping a painting or blowing motion of the flame was used.

Just as soon as the first weld was completed and before the casting could start to cool the job was quickly turned over and the second spoke weld made. The idea being not to lose any of the expansion on the first weld before attacking the

second. The second spoke weld was made in almost the same manner as the first in regards to detail. The only difference being that the

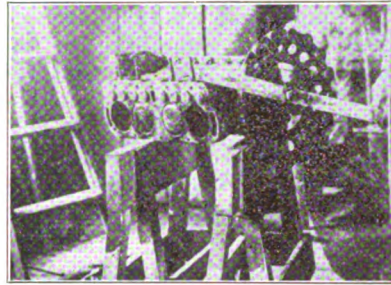

FRED CORRELL SAVES TIME IN FITTING FORD BEARINGS BY BOLTING A PIECE OF IRON TO THE REAR END OF THE CRANKSHAFT. IN THIS WAY THE BEARINGS ARE FITTED WITH A MINIMUM OF WORK AND DIFFICULTY

metal of the first weld which had seeped through the bottom of the groove was melted and thoroughly cleaned out before melting down the bottom of the second weld.

When the second spoke weld was finished the casting was returned to its original position and the burners arranged as described. The burners were allowed to operate until that part of the rim and spokes were red hot before applying the welding flame, the heated area included about a third of the wheel as explained previously. The first rim weld started on the inner side and worked out toward the teeth side. First the bottom of the groove was melted together along the fracture then a layer of metal was melted together along the fracture then a layer of metal was melted about a fourth of an inch thick over this. Working from the inside out again, layer upon layer was added the same as for the spoke weld. The flame was kept in motion nearly all the time, revolving in small circles, crossing the groove with each revolution. The filler was kept twisting and mixing in this weld too. The weld was fluxed in the manner prescribed for the other welds. And the last layer was blown clean and smooth with the pressure of the flame. The blowing is accomplished by directing the flame close to the surface until it commences to melt, then dropping the head diagonally, causing the flame to strike the metal at an angle, washing the fluid metal ahead of it. This blowing should not be prolonged as there is danger of oxidizing the metal and thus spoiling it.

After completing the first rim weld the burners were shifted around the wheel to heat another third of it including the second break and overlapping the first third. This weld was made like the first, then the wheel was immediately inverted to smooth the bottom side of both welds. Which was accomplished by the scraping and blowing method.

The welded half of the casting was covered with several layers of asbestos paper as soon as the last weld was finished. The burners were allowed to burn full force for several minutes before they were cut off. The casting was then allowed to cool about an hour before removing the covering. Picture No. 4 shows the welded sprocket with the clamps yet in place; the clamps were allowed to remain until the job was cold. It is sometimes good policy to tighten the clamps, as the job cools, to keep up with contraction. Little machining was needed except in the teeth. Tractor welds should be as neat in appearance as any other welds however, so make them look nice before they leave the shop.

SAVE THE BATTERY

When the gear shift lever is in neutral and the engine is running, gears in the transmission are revolving. The same is true when operating the starter. It requires considerable force to turn these gears through thickened grease, a force which is an unnecessary drain upon your battery. Simply holding out the clutch during the operation of your starter prevents all motion behind the flywheel, thus taking a load off the battery which during the winter is overworked at best. To prove this to yourself, some cold morning, shortly after starting your motor, place your gear shift lever in neutral, hold the clutch out, and throttle down your engine till it is just turning over. Then quickly let your clutch in. In many cases the engine will stall, due to the increased force required to turn the gears in the transmission.

Build Now
THE NATIONAL, STATE, AND COUNTY
ROADS WE NEED, AND
PROSPERITY WILL RIDE TO EVERY
AMERICAN'S GATE
U.S. DEPT. OF LABOR **W. B. WILSON**
Secretary

Ford Electrical Ailments and Their Cures

ROBERT STOCK

NERVOUS prostration, neurasthenia, et al., in the human body are caused by nervous disorders, all having more or less definite causes and definite treatment, and similarly the ignition system of the Ford car is susceptible to occasional nervous breakdowns that demand immediate treatment, and the cause once found the remedy will usually suggest itself.

Electrical equipment on automobiles runs the scale from a simple set of dry batteries to the single unit starter and generator that is a really intricate and complicated piece of mechanism but we intend to deal only with the nervous ignition system.

Five distinct parts compose the Ford ignition system, the magneto which is a part of the flywheel; the coil box located on the dash board; the timer or commutator or distributor, whichever you want to call it located on the front end of the camshaft; the spark plugs and finally the necessary wiring that

any cylinder and we then proceed to look around something in the following order: first see that the cable from the post on top of the transmission case is securely connected and that the insulation is not worn off so that the bare wire

appears to be in good order take a look at the contact post on top of the transmission case. By removing the three screws and lifting straight out it can be removed without difficulty. See that the contact spring is clean and that dirt and other foreign substances have not collected on the place where the spring rests in position. If the cause of the failure is not located in the places mentioned the chances are that it lies in the magneto pro-

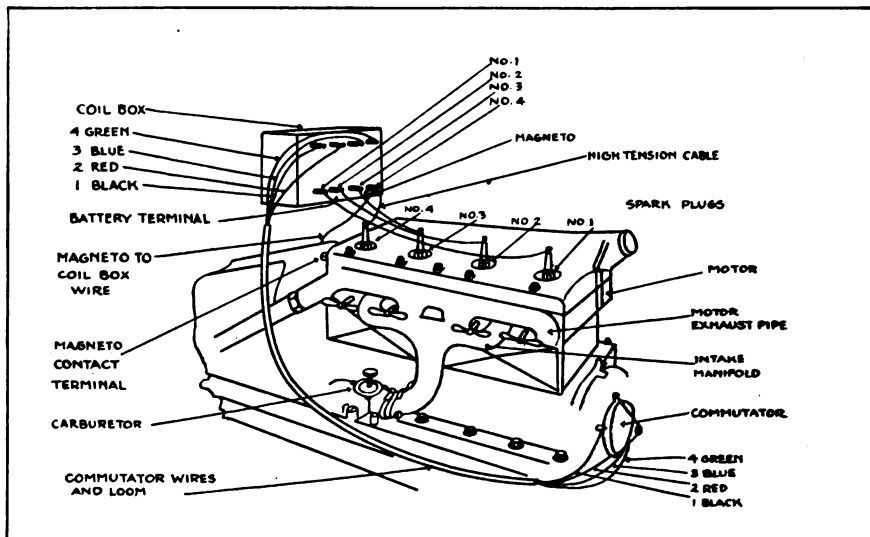
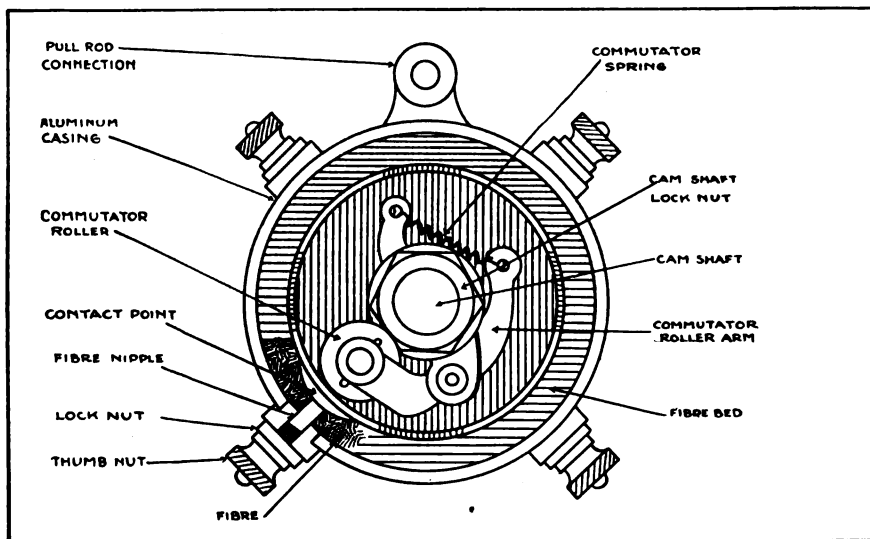

DIAGRAM OF THE FORD IGNITION SYSTEM



FORD TIMER AND DISTRIBUTOR

connects the various parts mentioned.

And now, being more or less familiar with the sources in any one of which trouble is likely to develop we pass to the commonest ailments and the forms in which they most frequently manifest themselves.

A complete failure will cause a total breakdown of the whole system—you cannot get a spark in

not touching the engine frame or other metal part and thus creating a short circuit. Next see that the other end of this wire is properly connected to the proper post that projects through the back of the dash. If there is nothing wrong here see that the switch is making contact and an inspection will generally show you how to remove the switch cover. If everything still

per and will require the services of someone familiar with this kind of work but, don't assume that the magneto is wrong until all other ways and means have been checked up and the trouble definitely located in the magneto itself.

It occasionally happens that the engine is hard to start and assuming that the carburetor, valve timing, gasoline, etc., are in order the trouble may lie with the electrical system, in this case the coils. Examine them. If you depress one of the springs on top of the coils you will notice that when it is depressed with the finger an opening shows between the contact point of the spring and the end of the contact screw. The adjustment of this spring should be as light as possible as the stiffer the spring the more current is required to operate it and if it is too tight it will be impossible to turn the motor over fast enough with the starting crank to make the circuit breaker, or buzzer as it is sometimes called, operate. This tight adjustment of the circuit breaker spring is the most common cause of hard starting when caused by the ignition system.

Note whether the contact points

are smooth or rough. If they are rough they should be smoothed down with a very fine file, (special files are made for the purpose) but never use emery cloth or paper to clean the contact points as particles of emery too small to be seen will be imbedded into the platinum and spoil the contact.

Clean out the commutator or timer with kerosene or gasoline and oil with clean oil. Examine the spring that holds the roller out against the timer wall. If the spring is too weak the roller will not press against the wall as it should. Finally examine the wires to the spark plugs for short circuits and the spark plugs as well. See that the porcelains are clean and that the spark gaps are not clogged with dirt and that they are not too far apart, as a very wide spark gap will make the motor very difficult to start.

When one or more cylinders lay down on the job see if all the buzzers or circuit breakers are operating evenly. Remove the cover of the coil box and listen closely or place the finger lightly against the edge of the vibrator spring. If one or more of the vibrators are not working adjust the tension of the spring as already mentioned and that the contact points are smooth. Then look for broken wires at the timer where the four timer wires are fastened to the four posts on the dash. If the wiring is O. K. and the buzzer still fails to respond, lift out the coil unit and see that the springs inside the coil box are bent in the proper shape and make contact

with the brass buttons on the side of the coil unit. If the four buzzers are operating as they should, examine the four posts where the spark plug wires connect to the dash. Occasionally dirt will collect around these posts and in wet weather moisture will get under the hood and cause short circuits also, examine the spark plugs.

If the engine misses when running slow see that the vibrator springs

are not too tight, that the coil spring in the timer is strong enough to hold the roller in firm contact. Possibly the interior of the timer will need cleaning out.

Engine misses at high speed. Inspect the timer. See that the four metal pieces which are imbedded into the fiber track are flush with the fiber surface. If a bump can be detected at each place it is the cause of the trouble as the roll-

is broken or one or more strands of the wire are broken and stick out from under the binding post this may cause a short circuit in that wire and be responsible for the delivery of a spark to a cylinder which is not in the firing position and thus causing a back fire and kick. When this trouble results crank with care. Always pull up on the handle and never push down on it. There is little danger in pulling up against a backfire and most of the injuries are caused by pushing down on the crank.

Of course, there are any number of other ailments that occur from time to time that require individual treatment, but anyone who takes the time to familiarize himself with the operation of the various parts should have little or no difficulty in locating any electrical troubles that may develop, not only of the Ford but of any other car.

HARDENING A TOOL FOR CHILLED CASTINGS

In many machine shops the mechanic has to machine castings which have developed exceedingly hard spots, caused largely by chilling in the mold. In other cases, a casting may have to be machined on a part which has been gas welded, leaving a very hard skin which rapidly blunts any tool. One machinist uses the following practice in hardening tools for this class of casting:

Heat a good quality of tool steel (not the high-speed variety) to a cherry red; plunge into salt water until cold; pull out and hold over a fire until a drop of water will evaporate when placed upon it. Then plunge into cold water. This, he claims, takes the hardening strain off the tool and prevents the edges from breaking out. In practice, a tool of this kind will work well on chilled spots and keep a sharp edge.

"THROWING THE BULL IN SYRIA"

Copyright, Keystone View Co.



PLENTY OF LIGHT AND VENTILATION CHARACTERIZE THIS SYRIAN BLACKSMITH SHOP IN THE ANCIENT CITY OF TARSUS

er, when traveling at high speed hits this bump and makes an irregular contact. A new commutator ring is the obvious cure. Cracked spark plugs will occasionally only show up when the engine is running fast or on a hard pull.

When the engine backfires and kicks, examine the wires leading from the dash to the timer, especially where the wires fasten under the timer screws. If the insulation

WHAT CONSTITUTES FORGERY?

Ralph H. Butz

"We have a New York draft here with your name on it. I wish you would see if it is in your handwriting," said the banker to a depositor. It proved to be a draft which the depositor had sent to a creditor a few days before. It was made out to the depositor, and he had neglected to indorse it before he mailed it. The man who received it had written the depositor's name above his own on the back of the draft. Both names were unmistakably in the same handwriting.

The depositor was indignant. "That man had no right to commit forgery," he declared. "I'm going to see my attorney about this, and if I can I'll make it hot for that man."

The attorney listened with interest. He agreed that the customer had no right to write his client's name on the draft, and would be very willing to take the case, if action were to be brought against the writer.

"Well, what can I do?" asked the depositor.

"First, you can get your money back," said the attorney. "The Negotiable Instruments Law provides that 'Where a signature is forged or made without authority of the person whose signature it purports to be, it is wholly inoperative, and no right to retain the instrument, or to give a discharge therefor, or to enforce payment thereof against any party thereto, can be acquired through or under such signature.' Your creditor, by writing your signature without your authority has rendered the draft void."

"What shall I do about it?" asked the depositor.

"Notify the bank that the signature is forged, and that you demand your money back," answered the attorney. "Then they will return the draft through the bank in which it was deposited, and your creditor will have to pay back the money he received on it."

"Will my debt to him be cancelled?" asked the depositor.

"No," replied the attorney, "you will still owe your creditor, just as

you would if the draft had never been sent."

"Then that won't do me any good. Can't I have the man put in jail for forging my name? Hasn't he committed a crime?"

"No, I should hardly say that he had committed a crime. Forgery is a felony under the laws of this state, but to constitute the crime of forgery there must be fraud. Forgery is one kind of fraud—fraud by making or altering a writing."

"But isn't writing my name

changed even a single letter or figure of the draft so as to defraud you or some one else, such a change would have been fraud. But simply to write your name because you had neglected to write it yourself was not a fraud, and was not forgery; although, as I said, it will render the draft void, if you say so."

"Oh, I will let it go. But tell me something more about forgery. What kind of papers can be forged?"

"Any kind of written or printed document can be forged. One author says it would be forgery for a merchant to cut false notches in a stick to show delivery of more merchandise than he really delivered, the stick being kept as a tally; but the majority of cases hold that forgery can only be committed in connection with a printed document. There are cases on record where the document was a deed, entries on an account book, and a recommendation. The forgery must operate to impose or to change a legal liability."

"I have in my safe a check for two hundred dollars, made out to J. W. Perkins. Perkins got me to cash it last night after banking hours, because he was elaving town on an early train this morning, and he forgot to indorse it. Will it be alright for me to indorse it? I need the money and Perkins won't be back for a week."

"If you have proof that the check was intended for you, you will not be committing a crime by indorsing it; but if you have any enemies you would better make sure that they don't have a chance to make you trouble. It will be the safe plan to sign your initials below Perkin's name, and then in case of dispute all you will need to prove is your authority; and Perkins can hardly deny that."

"Thank you very much," said the depositor. "You have saved me the use of two hundred dollars for a week."

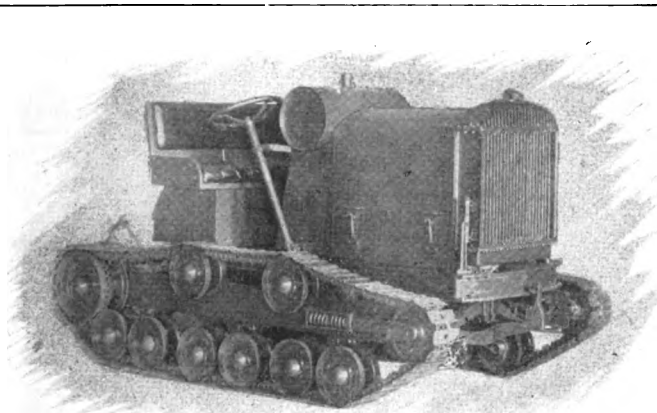

C. H. MARTIN IS THE INVENTOR OF THIS SIMPLE APPEARING TRACK LAYING TYPE TRACTOR DESIGNED TO PULL THREE PLOWS. OBSERVE THE ABSENCE OF THE MANY TRAPPINGS USUALLY FOUND AND THE AMPLE COMFORT SUGGESTED BY THE WIDE, UPHOLSTERED SEAT. THE TREAD IS MADE ENTIRELY OF PRESSED STEEL WHICH MEANS LIGHT WEIGHT AND GREAT STRENGTH AS WELL AS ECONOMY IN CONSTRUCTION COSTS

without my consent forgery?"

"Not always," said the lawyer with a smile. "I remember writing you a letter a few days ago, and putting your name at the head of the letter, and on the envelope afterward. Would you call that forgery?"

"No, of course not; but that is different."

"Slightly different, I admit," the attorney agreed, "and yet the two cases are somewhat parallel. I wrote your name in order to do you a service. Why do you think your creditor wrote your name on the draft?"

"Why, because he though I had probably forgotten it, and that it would save both of us time and bother if he should write it himself," confessed the depositor.

"That is just the point. There was no intention to defraud. If the draft had not been intended for him there would have been fraud, and the writing would have constituted forgery. Or if he had

Don't attempt to set your own standard of right and wrong, and expect everybody to conform to it.

Queries-Answers-Notes



THIS department is the meeting place where you are free to ask for information, answer questions, discuss shop matters and business conditions and any other notes you feel would be of interest to a fellow mechanic. Make use of this Department as often as desired.

Drilling Mould Boards—I am having trouble in drilling holes in cast mould boards and even after heating them and cooling they still resist a drill. Can you tell me what the trouble is?

H. P. Jensen, Oregon.

The presumption is that the mould board referred to is a chilled iron casting, in which event it is no wonder that you experience difficulty in drilling, because properly chilled mould boards are too hard to be drilled and chilled iron castings properly made are so hard that steel cutting tools cannot be tempered hard enough for practical use. We suggest the use of the oxyacetylene flame for cutting holes in such castings as the simplest and quickest method.

What Do You Like?—"The last number was a dandy. I like the different articles on tools."

D. R. Ceas, New York.

Proof of Value—"Renew my subscription for two years. I have not been blacksmithing for some time but I can't do away with my magazine."

G. A. Anderson, Utah.

Ontario Smiths Meet—At the eight annual convention of the Master Horseshoers' Association of Ontario at Guelph, Ont., during the week of June 19, many problems of interest were taken up and dealt with. The election of officers resulted as follows: President, George McVittie; 1st. Vice President, J. W. Slack; 2nd. Vice President, David Sallows; 3rd Vice President, J. McLarin; Secretary, R. B. Smallman; Treasurer, John Gardiner.

It was decided that the next annual meeting will be held at Toronto and that the annual picnic would be held at Hamilton on the last Saturday in July.

Reports of officers and committees were most satisfactory and showed the organization to have increased in membership and influence during the year and the financial report showed a flourishing and gratifying condition.

Drilling Spring Steel—I was visiting one of my neighbors' shops recently and after watching his difficulties in tempering a drill bit for drilling some spring steel I volunteered to fix him up with a method that I have found to be successful and thinking that the same information would be welcomed by others I'm sending it along.

I have a small can about two inches in diameter and six inches deep filled with beeswax and when tempering drills I heat the drill to a dull red, as you may call it and push it for its full length into the wax and allow it to stand until cold and it is then ready to drill anything that can be drilled.

I also have many springs to weld and the following method has given invariably successful results.

The ends of the spring are scarfed and they are then heated slowly to a fair heat. I have some small strips of stove pipe large enough to cover the scarf and on this is placed some Climax welding compound and I then proceeded to take a welding heat and weld the strips to each end, another weld is then taken to join the broken spring. So far I have not had any brought back to be re-welded again and so far as I am able to learn these welds are standing the strain as well as new leaves. One important thing to be emphasized in all spring welding is to avoid heating the metal in a hurry, allow the welding heat to be reached gradually.

G. A. Anderson, Utah.

Tempering Cold Chisels—In answer to the inquiry of L. E. K., of Pennsylvania for a method of tempering cold chisels, will say that if he or any other of the craft will take six bars of Grandpa's soap, three pints of sweet milk (goat's milk preferably) and a teaspoonful of alum. Dissolve the soap and alum over a slow fire and then add the milk and mix thoroughly. This makes a compound that will give results that will surprise him. In addition to the above there should be used a solution consisting of two gallons of rain or distilled water to which is added four ounces of common salt and four ounces of borax, preferably in crystals). This should be well dissolved in the water.

There are certain methods in working steel for edge tools that should be adhered to. First, tool steel should never be heated to more than a cherry red in working and then a piece of steel should be worked under the hammer on one side only to each separate heat. Don't try to hammer out a piece of steel flat and then turn it up and hammer edgewise at one heat. Work it in in one position only at a time and then reheat it for the next operation.

After the piece is shaped to the desired form heat it to a low red and immerse into the soap compound and allow to remain until cool. Remove and wipe off and reheat to a low red on the point and then temper in the usual manner in the water compound.

In tempering cold chisels they should not be heated back more than a half inch from the point and when dipped into any kind of liquid should not be allowed to remain still at one point. Immerse slowly and withdraw instantly and allow the temper to run down in the usual manner.

The two recipes should be always used together to secure results and a beginner should use these alternately until he familiarizes himself with their use as well as the steel he is using. A little patience

is all that is required to get results from the formulas given and there are more blunders made by overheating steel than any one thing in its manipulation and then again you can work your steel cold, don't hammer it after it ceases to be red.

W. L. Lewis, Oklahoma.

Acetylene for Welding—Will the acetylene used for automobile headlights do for welding purposes?

P. W., New York.

Yes. The acetylene is the same provided you are able to use it and it is assumed that our inquirer has in mind the Prestolite tank. If we are correct in this it will probably be found rather difficult to attach the controlling valves and gauges to such small tanks and also it is possible that the pressure of the gas in the small tank will not run as high as the gas in the regular acetylene welding cylinders.

If our inquirer has in mind the use of acetylene gas from one of the small generators that were formerly a regular part of equipment on a great many cars a few years back it would be hardly possible to use this source of acetylene for welding purposes because of the insufficient volume of gas such apparatus is capable of generating not to mention a number of other difficulties that would stand in the way of the use of gas obtained in this manner.

R. R. Smiths to Meet—The International Railroad Master Blacksmiths' Association will hold its annual convention in Chicago on August 19, 20 and 21.

Resetting Auto Springs—I have a friend who asked me to reset his automobile springs and would like to know how to do the job right. There is a smith here who resets them by hammering more bend in them cold. I would think that would break the grain of the steel and to heat and reshape and temper without packing the steel would not do either. I would like to hear from you on the subject. Also, would like to know what to use to cover the resistance coil in the regulator of a Buffalo electric blower. I know what kind of wire to use for rewinding but cannot keep the cover from cracking and that leave the air to the wire and it burns out. It is the part that has the buttons on a variable speed regulator.

R. Callin, Maryland.

Six of one and a half dozen of the other is expressive of the two systems of setting springs you mention. An automobile spring is something we consider that few are competent to handle with any particular degree of success. As an original idea with the editor he would suggest that the leaves be run through a tire bender cold. This idea would seem to have considerable merit over either of the other two methods in the blacksmith shop and it would seem to have the advantage of reducing the time and effort required to a minimum. Also the set would be uniform on all the leaves which would be difficult to accomplish by hammering.

Fine ground asbestos mixed with sodium silicate into a thick paste or dough and pressed around the resistance wires and then dried out in an oven should remove all trouble with the regulator coils. These materials can be obtained from any plumber or heating contractor and it is quite possible that some form of asbestos cement can be obtained such as is used

for covering the exterior of heating boilers and furnaces.

Spotlight for Tractor—Having received some wonderful help from you before, I have two questions I would like to ask.

1—What kind and size of bulb will it take in a spotlight to hold a Fordson? By this, I mean without them burning out continuously.

2—Is it possible to connect a spotlight on Moline tractor magneto 1916 model B? If so give kind of bulb and how to connect spotlight. This last question may seem foolish but unless I knew I would not ask. As to the Fordson I know it is possible for I have connected one but can't figure out what bulb it takes.

C. R. S., Ohio.

1—Any 18-24 volt lamp can be used in a spotlight attached to Fordson tractors.

2—Regarding a lamp for the 1916 model B Moline tractor. As far as we are aware there is no generator or battery on this model unless it was one of the very late 1916 models. If there is no provision for current it will be necessary to provide either a generator or storage battery. Later Moline models are equipped with a Remy 6-8 volt lighting, starting and ignition outfit and a spotlight is provided with the tractor as a part of its regular equipment. Any standard 6-8 volt bulb may be used with this circuit but as far as applying a spotlight to the magneto there's nothing doing.

A variety of automobile and tractor spotlights are manufactured by the Corcoran-Victor Co., Cincinnati, O.

Welding Cast Steel—I would like to know how to weld cast steel with a Waterhouse welding machine. I have tried a number of ways without success. Do you use any flux? What pressure do you carry the oxygen in relation to the acetylene?

M. V. Monahan, Massachusetts.

You are not specific enough in your question. You should have told us what kind of cast steel you are having such poor success with. Or at least tell what the castings were used for. And in this connection we could probably have helped you more if you had stated what size torch or tip you used on the work. Also the kind and size of filler you employed. These things make a very great difference in the weld.

There are several kinds of steel used in different castings such as manganese, vanadium, nickel chrome, high carbon, etc. Perhaps you were attempting to weld some special brand of steel. If so you should have used a filler rod of the same material, although you could possibly have used Tobin bronze with fair success.

For common cast steel a filler rod of what is termed Norway iron will make a good weld. But this rod should be of proper size to suit the thickness of the steel to be welded.

The manufacturer of the machine you mention should furnish you with tables for choosing the right tip or torch according to the job, also the correct size filler for the flame and metal thickness. If the rod is too heavy and the tip too small the metal can not be melted and fused fast enough which results in a poorly connected weld. If the tip is too large and the rod too small you will probably

burn up the metal in the filler and the weld. This is the worst trouble in welding steel. It oxidizes or burns very easily.

A strictly neutral flame, half oxygen and half acetylene, is the only safe one for cast steel. Too much oxygen causes the steel to burn and fly away in a shower of sparks. An exaggeration of this is seen in the cutting process wherein a great excess of oxygen is employed.

It is not necessary to use flux of any kind. All bits of dirt or slag must be dug out with the filler rod or a skimmer when the metal is melted.

One factor in steel welding is to be sure to get the weld hot enough without burning it. It often looks hot enough when it is not yet melted deep enough to make a solid weld. Keep the flame in constant motion while welding. Swing it back and forth across the weld or in tiny circles over the surface. Get your casting red hot in a charcoal or other fire before starting to weld. Then weld deep and rapidly, working in the new metal with the rod by twisting and poking it in the melting weld. Endeavor to keep a stream of metal flowing from the end of the filler into the melting weld.

David Baxter.

Mending Ivory—There is a man who came into my shop and asked if I could cement or repair ivory after it is cracked. I told him I did not know anything about it but would write and ask you about it.

J. B., Michigan.

About the simplest way of repairing broken ivory articles is to take a small quantity of Lepage's glue and mix with a small amount of zinc white so that it will match the ivory better. If the article to be repaired has to stand considerable usage, as for instance an umbrella handle, it would probably be advisable to join the parts with a small dowel pin, which could be held in place by melted shellac or sealing wax, and using the glue as mentioned.

Phosphor Bronze—Phosphor bronze contains phosphorus and I wish you would tell me how the phosphorus is introduced into the metal.

John Dawson, Kansas.

Phosphorus in its pure state is combined with the metallic alloy to form phosphor bronze. The phosphorus is purchased in sticks about as thick as the finger and weighing about two ounces each. One or more of these sticks of phosphorus are introduced into a short tube made of clay or graphite. This tube is attached to the end of a metal rod and strips of tin or copper that are fastened over the end. The tube is plunged into the molten metal and held there until the phosphorus has been absorbed. Another plan is to use an iron cylinder at the end of a long handle. Several sticks of phosphorus are inserted into the cylinder which is then lowered into the molten metal and allowed to remain until the phosphorus has been absorbed.

Inasmuch as pure phosphorus ignites at a low temperature, it is a dangerous material to handle. Consequently the sticks of phosphorus are often coated with a deposit of copper. This is done by placing the sticks of phosphorus in a dilute solution of sulphate of copper for about one half hour. The deposit of copper on the outside surface of the stick keeps the air from contact with the phosphorus and the stick may be safely handled so long as

the copper is not broken. The coating is thin so that it does not hinder the absorption of the phosphorus when the stick is plunged into the molten metal.

Inboard and Outboard—I have read somewhere of "inboard" and "outboard" electric starting motors. Can you tell me what is meant by these expressions?

J. D. O'Dell, Kentucky.

To meet the increasing requirements of various engines the Bendix starter drive is installed in two ways, giving what is known as inboard and outboard types of mesh. In the outboard type the Bendix drive pinion travels away from the starting motor. In the inboard type, the Bendix drive pinion travels toward the starting motor as it meshes with the flywheel.

In Luck—"I was lucky enough to get hold of a copy of the Auto & Tractor Shop and was well pleased with it. Please let me know what the price is a year as I want to take it.

M. L. Hoffman, Maryland.

Removing Carbon—Will you please tell a subscriber to your paper how he can best remove carbon from the cylinder of his gasoline engine? Once I took an engine apart to get carbon out and had so much trouble getting it back together that if there is any other and easier way I should like to know it.—C. W. B., Indiana.

We do not blame you for not wanting to take the pistons out. It is a hard job usually to get them back in again, altho perhaps doing so is the surest way to get carbon deposit out. For the man on the farm, however, maybe the most convenient way is to soak it out, by using either denatured alcohol or ordinary kerosene. In order to do this successfully turn the engine to outer dead center and fill the combustion chamber of the cylinder with either the alcohol or the kerosene. It is always best to do this while the engine is warm.

Leave the liquid in the cylinder over night and, in the morning, drain and rinse the cylinder out. Unless the deposit was very heavy and hard it will have become so softened that it will come away readily. If this sort of treatment is given to the engine at regular intervals you will have very little trouble with carbon.

If your engine has the splash system of lubrication all the oil should be cleaned out of the crank case after draining the cylinder. This for the reason that some of the alcohol or kerosene will surely have gotten mixed with the oil in the crank case, making it unfit for further use.

Getting Ideas—From where do your business ideas come? Every business needs fresh ideas, just the same as the body needs daily food. Only by the constant flow of vital business thought and new ideas can any business grow. Without these it may live, but will have little, if any, growth. Every new problem must be met with an idea, not necessarily a new one, but an old one with a different application.

Isolation from other business men is not a very good condition to receive new ideas. Just as men mingle together, express themselves, exchange experiences, are new ideas generated, passed along, absorbed, put into practice. The local association meeting is one of the very best of idea exchanges. The business man who fails to attend his local trade organization meetings is missing far more than he imagines.



AUGUST, 1919

| | |
|--|-----|
| Getting the Car Ready for the Camping Tour | 263 |
| Why Wagon Treads Have Been Standardized | 270 |
| Benton's Recipes | 273 |
| License Plates from all the States | 274 |
| Welding an Aluminum Crank Case | 276 |
| British Correspondence | 278 |
| "Never Too Old to Learn" | 279 |
| Andean Horseshoeing | 280 |
| How Auto Bodies Got Their Names | 281 |
| Value of Proper Cost Accounting System | 282 |
| Manufacturing Razors | 281 |
| Queries, Answers, Notes..... | 285 |

AMERICAN BLACKSMITH AUTO & TRACTOR SHOP

VOLUME 18

AUGUST, 1919

NUMBER 11

BUFFALO, N. Y., U. S. A

Established 1901. Published Monthly at the Sidway Building, Buffalo, N. Y., by the

AMERICAN BLACKSMITH COMPANY

Incorporated under New York State Laws.

WILLIAM F. WENDT, *President.*

WALTER O. BERNHARDT, *Editor.*

SUBSCRIPTION PRICE:

For \$1.00 per year, payable in advance, The American Blacksmith, Auto & Tractor Shop will be sent, postage prepaid to any postoffice in the United States. To Canada, \$1.25; to other countries, 6 shillings. Reduced rates to clubs of five or more on application.

Remittances may be made by money order, express order or checks payable to the American Blacksmith Company. We will also accept uncanceled postage stamps or currency, but for safety these should be sent by registered mail.

Subscribers should notify us at once of non-receipt of paper or change of address. In latter case, give both old and new address.

Correspondence on all smithing subjects solicited. Always give name and address, which will be omitted in publishing, if desired. Address all communications to the

"AMERICAN BLACKSMITH COMPANY"
BUFFALO N. Y

Copyright W. F. Wendt Publishing Company, 1919 "

Cable Address: "Blacksmith, Buffalo"



THE EDITOR WONDERS

The Editor lives within sight of a substantial brick building that, in days gone by, did service as a livery stable but which is today occupied by an automobile garage—not a repair shop in any sense of the word. The Editor knows the owner of this establishment personally and often drops in for a friendly chat or to borrow a monkey wrench. The proprietor knows nothing about automobiles, doesn't pretend to and don't care to particularly and he neither owns nor drives a car; he merely runs the place and collects the money. He has storage space for approximately 30 cars for which an average of \$7 each per month storage is collected. The oil company he buys his gasoline from has installed a \$500 gasoline pump in front of his place at a merely nominal rental, without expense to him. His profits on a gallon of gasoline at the present time is something like 2½ cents per gallon which he makes by merely turning a crank. Besides he sells a line of such small accessories as spark plugs, etc., Recently he has taken on an agency for a well known tire and installed an electrically operated "free" air pump. This man is making money, he is not

working hard to get it and really finds the business something of a bore because he has so little to do.

Within gunshot of this place and on a much more traveled street is a blacksmith shop conducted by an officer of the state association. He is a good blacksmith and a good workman but instead of doing more business he is doing less and he is certainly not making the money in proportion to the work he does.

The blacksmith in question owns a substantial brick shopbuilding that could be readily converted into a garage and repair shop at little or no expense. At present a good part of his building could be used for automobile storage purposes as he is never rushed with more work than he can handle himself.

Here are two cases the Editor personally knows of—one man is taking things easy and "cleaning up" the other is carrying on a business, possibly at a profit, but nevertheless conducting a business the possibilities of which are ever growing less.

Someone will have to remain to shoe horses, that much is certain but what puzzles the Editor is that there are so many blacksmiths who would rather stick to horseshoeing than turn to a business that has the unlimited money making possibilities of some branch of the automobile business.

Some there are so fanatical on the subject of horseshoeing that they confidently predict "the day of the horse will return." As a matter of simple information the horse never had his "day" even before an automobile was heard of—the only people who owned horses were those who had to have them or who had plenty of money. Comparatively few people owned horses for "pleasure".

The Editor knows some horseshoers and has heard of others who even carry their prejudice against automobiles to the extent of refusing to ride in an auto and

who feature meetings of their unions and conventions with foolish talk about what the future has in store for the horseshoer.

There are a lot of men, who know more in a minute about real mechanism than the average garage owner does in a week, that have taken this stubborn stand against progress.

And the Editor wonders what a lot of them will be doing in a few year's time.

Take the next rainy day and inventory the unoccupied space in your business establishment. Measure it up in square feet and estimate what it costs in dollars and cents per year, then set your thought motor at work and devise some logical, reasonable way to make that space meet its own proportionate part of the overhead and pay a profit as well.

To tie up a large amount of money in slow moving stock is a poor business policy and the profits will be eaten up by the tie-up in cash. Keep enough stock to give a reasonable selection and to supply the needs of your customers adequately. Anything beyond this is a mistake. Overbuying handicaps many a man's business credit.

DON'T GIVE MONEY TO AGENTS

The American Blacksmith, Auto & Tractor Shop DOES NOT employ subscription agents. Any person representing himself as such is an imposter and should be so dealt with. Notify us immediately if anyone claiming to represent this journal calls upon you.

Putting the Automobile in Shape for Camping

ALBERT MARPLE

WHEN the inexperienced motorist begins to plan the camping equipment for his auto it is generally a case of take everything in sight, even to the piano and the refrigerator, for, he argues, music will go mighty good on the cool summer evenings among the trees, while a refrigerator is always a welcome luxury. When this fellow has his machine all packed for the hills the neigh-

cutting down weight by eliminating the unnecessary articles and utensils—it means cutting away every pound and ounce of weight from the absolutely necessary features that are taken along. If the kitchen range, the dining room table and the “withered” oak bed room suit are included in the outfit, it will do little good to leave home a few of the smaller “extras”. The weight-cutting idea must be applied to each individual item included in the outfit, for if the old faithful motor, which has never balked yet, is to be expected to keep going upgrade and down, it must be given a real chance. It is really pathetic the loads some folks take to the hills on their machines, and the strange part of the whole thing is that no matter how badly a car is burdened some people expect it to do its “bit” just as efficiently and with practically the same effort that it exerts while making the rounds of the boulevards in the city. These folks generally learn through heartbreaking experience.

However, in the wild endeavor to eliminate weight from the outfit the motorist must not go to the other extreme and leave things at home that are absolutely necessary, for, to a great extent, the enjoyment of the trip depends on having the outfit complete. To have the outfit complete means to include in it everything that is really needed, and which, if left at home, would result in a “hole” being made in the outfit.

There are three separate divisions to the camping outfit that the motorist really must take along, and these are the bed room, the kitchen and the dining room. If the outing is to be enjoyed to the greatest possible extent each one of these divisions must be taken up and considered separately and each one must be planned and completed before the nose of the “old cutter” is turned toward the hills. To the extent to which the arrangement of any of these details is deferred until the trip is started is the enjoyment of the outing bound to be decreased.

Accompanying this story are photographs which show how

“others” have solved the different camping out questions. None of these features were evolved in a moment, but each was the outcome of actual experience, and the fellow who has never “been there” will do well to at least look these features over and to give them a little consideration.

Bed Room — Many motorist-campers believe that the arrangement of the bed room or sleeping facilities is the most important question to be solved in connection with the automobile camp outfit. Almost anything can be put up with in the mountains, so long as the hiker or the fisherman or the hunter has a good place to sleep upon arriving at camp after a “hard day.” Sleeping on the ground rolled up in a single blanket may be all right in its way, but this method of sleeping out is not what is desired by the average motorist who has but two or three weeks to spend in the open each year, for before the night is over



FIG. 1.—“GOOD MORNING” SLEEPING SAILOR FASHION APPEALS TO THE CHILDREN

bors think he's leaving town for good and that he is too “tight” to hire a dray. All goes well until the outfit hits the first real grade, then the motor balks and the joys and delights of the automobile camping trip begin in earnest, and they continue until the moving van returns once more to the old home fireside—if it ever does. The next time this fellow goes for an outing trip in the auto his outfit consists of a pancake turner, a frying pan and a coffee pot, with possibly a knife, fork and spoon thrown in for good measure. He has learned his lesson and consequently he has sworn to ever after “go light.”

“Going light” means more than



FIG. 2.—SLEEPING ARRANGEMENTS FOR CHILDREN ARE SIMPLE

the ground gets mighty hard “in spots.”

Figures 1 and 2, of the accompanying illustrations, show a dandy automobile bed room arrangement which is intended to accommodate

three people—two adults and a child under ten years. This outfit was used for an entire season of camping and touring with entire satisfaction. The back of the front seat of this automobile has been cut

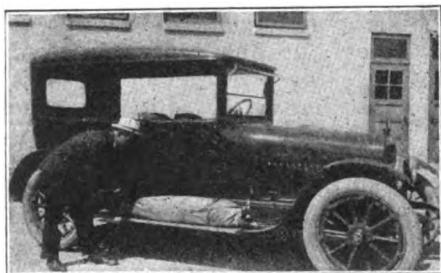

FIG. 3—ANOTHER ARRANGEMENT OF SLEEPING ACCOMODATIONS

down and hinged at the lower edge so that when dropped backward it fills the space between the back of the front seat and the front of the back seat, thereby converting the seats of the car into a bed large enough to accommodate two full grown persons. (The work of cutting down the seat back in this manner is now being done in different sections of the country.) For the child a hammock, as long as the car is wide and as wide as the two main uprights of the car are apart, is made, so that at night the little one sleeps directly above the bed formed by the seats, the hammock ropes being fastened to the uprights of the top. If it rains, or the night becomes too cold or misty, the side curtains may be hung, enclosing the car.

The sleeping arrangement shown in Figures 3 and 4 is intended for four adults, there being a bed on either side of the car. This outfit, including the two beds complete, weighs not more than 75 pounds and may be built for about \$15. Each bed is four feet wide and six feet long, the bed sections being made of heavy canvas. The head end, which is toward the rear of the car, is supported by a piece of strong angle iron, the end of which rests upon the hub of the rear wheel, there being a curved extension which passes between the spokes and grips the inner edge of the rim, keeping the angle iron from turning. The outer end of this iron strip, as is also the end of the strip at the opposite end of the bed, is supported by an upright piece of wood, up the center of which are drilled a number of holes, these making it possible to bring the bed to a level position regardless of the slope of the hill

upon which the bed is being made. The canvas of the bed is fastened permanently to the head angle iron. The foot angle iron extends from the upright stake across the running board, continuing below it and fastening to a bolt which has been attached to the forward running-board brace.

To the foot end of the bed canvas a small iron rod has been sewed, this end having been left loose from the angle iron. The canvas naturally stretches and to be able to take this up a rope lacing has been run from the rod in the foot end of the canvas to the angle iron. To keep the outer posts from falling inward when weight is put upon the bed, guy wires have been strung from the outer ends of the angle irons to the front and rear springs. Both of these beds and the tent which covers them may be erected by two persons in ten minutes and may be taken down in the same length of time. When not in use

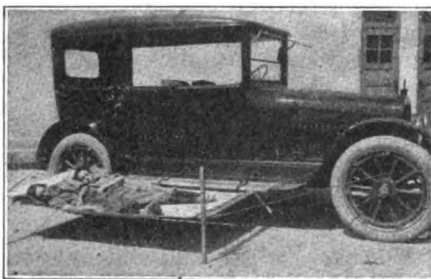

FIG. 4—HOW THE BED SHOWN IN FIG. 3 IS CARRIED

both beds are rolled and placed in a single bag and strapped to one of the running boards. While excellent for ordinary camping both of these bed arrangements are especially good for the motorist who is touring, on account of the speed in which they may be assembled and taken down.

As most folks want their food cooked, whether at home or in camp, it would seem that about the next feature of importance in the outfit, is the stove or cooking arrangement. There are dozens of kinds of camp stoves for the motorist on the market. Many of these have merit while some were made to sell. Some stoves are too big to be taken on the ordinary camping trip, others are too small for satisfactory service, and so on. The thing for the motorist to do is to "think up" some kind of a stove that exactly suits his individual need, the principal ideas in planning such a feature being the elimination of bulk and weight with the

securing of the maximum amount of practical service. Forget the looks—the pretty stoves are generally failures. Build a stove that really "produces the goods" and you will be envied by every camper you meet.

In Figures 5 and 6 are two valuable suggestions along the camp stove line. The gasoline stove under the hood, Figure 5, is at the same time both novel and practical. The stove is clamped to the exhaust manifold and may be swung upward and out of the way when not in use. The fuel is piped from the gas tank of the machine, this pipe being provided with a valve which may be closed when the stove is not being used.

The feature shown in Figure 6 is known as the exhaust stove, deriving its name from the fact that the heated gases of the exhaust, which would otherwise be wasted, are used to cook the food. The exhaust pipe is tapped up close to the engine, the gases going from the main pipe through the pipe leading to the stove, around the open sides of which it circulates, going out through a pipe which parallels the regular exhaust pipe at the rear. While traveling the food to be cooked for the coming meal is placed in this stove at a given time before the repast and upon stopping at a specified time the food is cooked and ready to serve. This is SOME fireless cooker, and is especially valuable to the motorist who is touring from place to place.

Because of its simplicity many a reader will probably doubt the value of a stove composed of a single piece of sheet iron, but the truth is that it is probably the most "versatile"



FIG. 5—A GASOLINE STOVE THAT IS ALWAYS IN PLACE AND IS CONNECTED TO THE GASOLINE SUPPLY LINE

stove ever devised. This piece of sheet iron is 18 inches wide, 24 inches long and a quarter of an inch in thickness. Upon making camp, stones may be arranged in two piles, running parallel to each

other, and the plate laid upon these, or if no stones are at hand a hole, with sloping ends may be dug and the plate laid over it. It works



FIG. —THE "EATS" ARE COOKED IN THIS FIRELESS COOKER FROM THE HEAT THROWN OFF BY THE EXHAUST PIPE WITH WHICH IT IS CONNECTED

equally well either way. When not in use the stove fits beneath the rug at the bottom of the car and out of the way. Being made of heavy metal it retains its heat, for keeping the food warm, long after the fire has been permitted to die down. A meal for six persons may be prepared on this stove, which weighs not more than 10 pounds, and costs about 50 cents. As an easily carried, ever-ready stove this feature would be hard to surpass.

After the food has been cooked it must be "served up" in a satisfactory manner, this calling for a table. Although the table should be light in weight it must also be strong and rigid. The wobbly table is a calamity, as the camper who has one will soon learn. Therefore it pays to plan carefully and build well. Two tables used in motor campers are shown in Figures 8 and 9. Figure 8 shows the rolling table, which when not in use rolls into a small bundle and fits within the tool box. For use it is unrolled and is held straight by a stick which runs underneath, the outer end being supported by an upright. This feature adds not more than three or four pounds to the outfit,

and, during transit, is not visible.

Figure 9 shows a drawer table, arranged beneath the small rear platform, which has been attached to this car especially for camping. During transit this table or drawer serves as a utensil carrier. One motorist-camper out west uses a regular folding table, the legs folding beneath the top, on his camping trips. He leaves the seat cushions of the car at home, to eliminate weight, and in their places he lays the various blankets and other pieces of bedding. After being folded the table is laid between the layers of bedding and out of the way. There are a number of folding camp tables on the market which weigh very little and take up very little space, but which are worth their weight in gold during a camping trip.

Another motorist out west thought it might be well for him to devise some special means of carrying the "grub" that must be taken along on all camping trips. For this purpose he devised what has been termed the "running-board kitchen" shown in Figure 10. This consists simply of converting the runningboard into one long food chest, which has been divided into several compartments for the carrying of different kinds of edibles. This motorist has gone so far as to fit one of the compartments up as a refrigerator, this permitting him to take a several days' supply of fresh meat and vegetables into the mountains with him. Upon arriving at camp the food may be either left in these compartments or placed in folding cupboards that are carried along.

The few features here described will give the motorist-camper some idea of what is meant by the term

EXTINGUISHING GASOLINE FIRES

While pure sawdust gives excellent results in putting out a small gasoline fire, a mixture of 10 pounds of bicarbonate of soda with 12 pounds of clean sawdust is the best medium to have on hand. Have the sawdust dry and free from chips. The action is that the sawdust forms an air-tight blanket as it floats on the burning liquid, and at the same time the heat of the flame generates carbonic acid gas. This gas, together with the sawdust keeps away the oxygen in the air from the flame and quickly smothers it.

"go light." It means take nothing that will not actually be used, and cut everything that is taken down the last notch in bulk and

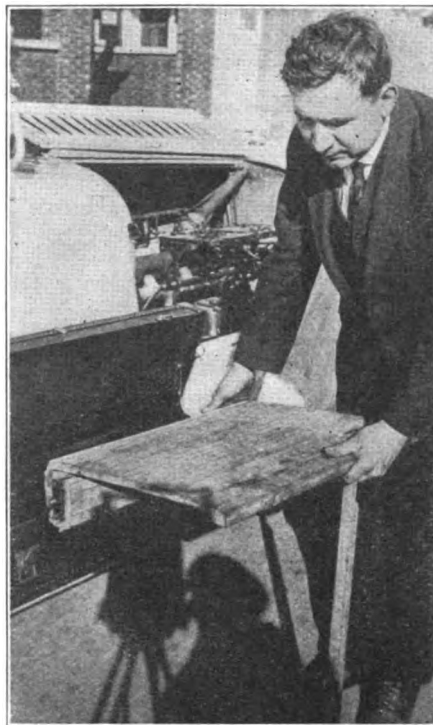

FIG. 8—THE TABLE THAT ROLLS OUT OF SIGHT AND OUT OF THE WAY AND OCCUPIES A MINIMUM OF SPACE

and weight. The faithful motor is a "willing old hoss" so give it a chance by not carrying along a ton or two of excess junk—things that may better be left behind.

In painting machinery, boiler pipes, smokestacks, etc., the best medium is asphalt paint or varnish. Another paint of similar nature is procured by mixing ground graphite with coal tar. Where economy is necessary use black (petroleum) oil, which can be used for woodwork as well as for the above. While the oil is good it, however, takes a long time to dry thoroughly. Paint for grinders, beams and similar work can be made by mixing litharge with boiled linseed oil.

DON'T STOP

When someone stops advertising, someone stops buying.

When someone stops buying, someone stops selling.

When someone stops selling, someone stops making.

When someone stops making, someone stops earning.

When someone stops earning, someone stops buying.

HOT WEATHER HINTS FOR TRUCK DRIVERS

FIRST of all, it is necessary to understand the cooling system. Do not expect the truck to labor in low gear up long grades or through deep sand, perhaps with a trailer, and still keep cool if carbon

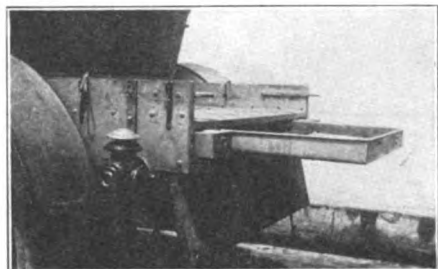

FIG. 9—AN ODD CORNER AT THE REAR OF THE CAR THAT IS CONVERTED TO CARRY ITS SHARE OF THE LOAD OUT OF SIGHT

deposit is permitted to accumulate in the cylinders, if insufficient water is put in the radiator, if the oil level is low or the oil is of the wrong kind.

At the beginning of the season it is ordinarily necessary to change the carburetor adjustment, that in summer being a trifle leaner than that for winter. Overheating is sure to result if the carburetor is improperly adjusted.

Timing has an important bearing on cooling. In hot climates where temperatures are excessive for a considerable part of the year, the engine may be made to run cooler, but at a slight sacrifice of power, by setting the camshaft one tooth ahead (earlier) on the timing gears, so that the exhaust valves open earlier. A weak spark has the same effect as late spark timing, and overheating will result.

Difficult grades can be made with greater speed and less fuel in intermediate than if the engine is permitted to labor in high to the point of stalling. Contrary to popular supposition the engine will cool better if it is not obliged to labor excessively.

Keep the exhaust clear of obstructions and do not allow mud to cake on the outside of the muffler or to clog the outlet.

The radiator must be filled as full as possible. Do not allow the overflow pipe to become clogged, or flattened by a blow or kink or slip down in the radiator.

Use only the best quality of rubber hose on water connections. The inside of cheap tubing is apt to

dissolve and the rubber particles clog up the system. Go over hose connections in the spring because some anti-freeze solutions have a deleterious effect upon the rubber. Also they leave a scum inside the radiator which will not dissipate the heat. It must be cleaned out.

In filling the radiator only clean water should be used. Strain the water through a cloth where none but dirty water is available. Above all do not use buckets in which oil has been kept.

Keep the fan clean and well greased, so that it will turn freely.

Not all of the cooling of the engine is effected by water; but lubricating oil plays an important part as it cools the bearings. Keep the crankcase clean; it cools the oil. It has been found that gasoline washes the lubricant from the cylinder walls and a mixture of gasoline and oil runs into the crankcase where in time it destroys the lubricating qualities of the oil. For this reason the oil in the crankcase should be drained and replaced with new oil every 1500 miles. If this is not done the oil will be unable to properly lubricate the rubbing surfaces and heating will result.

The average working temperature of oil in summer is higher than in winter, and so oil of the same body will be thinner. Sometimes it is advisable to use a grade heavier oil in summer. In excessively hot spells an especially heavy grade of oil may be required to maintain the oil at the proper consistency in operation. When a heavier oil is used care should be taken not to work the engine too hard before it is warmed up. Buy oil only from reliable refiners.

HOW AMERICAN TRACTORS OFTEN FAIL ON SCOTTISH FARMS

John Y. Dunlop

Farmers in England and Scotland at the present time are very much in need of tractors because of the shortage of labor the high price of horses and the necessary short spring plowing season.

These three reasons are crowding on the farmers every day who are hoping against hope that they will not be compelled, for economic reasons, to buy something which will not be satisfactory.

The farmers know what they are waiting for and if he is compelled to take something as a makeshift

will do so, but when the right machine to suit the British farmer is put on the market he will lose no time in scrapping an inefficient machine to get an efficient tractor.

The British farmer has learned much about tractor farming during the last three years and he knows that if he can get the tractor to suit him he can make his farming pay and that he must have it to keep his farm producing profitably.

One has only to think of the tremendous farming areas in America to realize how the American tractors have with, few exceptions, proved failures in Britain.

The farms there are so uniformly level that one can travel many miles across the principal farming districts looking in vain for a hill or even a slight rise in the ground.

Again if one looks at the climatic charts it will be found that the autumn plowing season is quite a long, open season as compared with the autumn in Britain.

It is almost impossible for American Manufacturers to realize the conditions under which tractors have to work both on English and Scottish farms to compete with horse cultivation.

In one district where they had obtained an American tractor, and a very good one at that, it was found that when starting to plow that the wheels picked up so much mud as to stop the work. A cable was dispatched to the maker stating the trouble and the reply was if it is too wet for our tractor it is too wet to plow. If plowing were

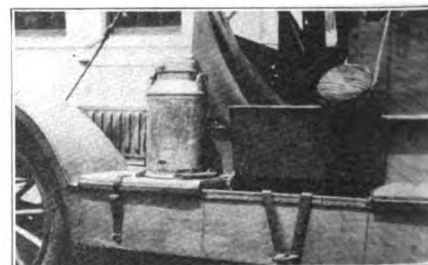

FIG. 10—STORAGE SPACE PROVIDED ON RUNNING BOARD FOR FOOD AND OTHER SUPPLIES

only done in favorable and dry weather in our country very little of the arable acreage would be farmed. Of course we know that the American farmer would never think of plowing his fields when they are as wet as those plowed here because he believes it would ruin his land and so it would. However, there is a little peculiarity of

the British climate which prevents that ruin. The heavy frosts in the winter, causing the ground to freeze and thaw several times during the season, breaks up the heavy clay furrow so that spring finds it in good condition.

What we need for farm work in Scotland is not a fair weather machine but an all year machine which can work where horse plowing has been done without damaging the tractor or the sod.

It must not be of such light weight as will cause it to slip its wheels when the ground offers poor footing or so heavy that it absorbs most of its own power to pull it along or to pack the ground so solidly as to prevent improper drainage.

The failure of the American tractors in England and Scotland is due somewhat to the motor truck style of differential gear which will never stand the strain of tractor work when hills must be plowed as well as level fields and the want of relation of the weight of tractor wheel grip and engine power.

Just now we have many makers in our country who are all aiming at being able to supply a British machine to suit the British farmer and the newest type to be put on the market a tractor brought out by a Glasgow engineering company.

This tractor after its trials is claimed as being able to give satisfaction in any part of the world and is not built to work under ideal conditions but under any conditions of weather.

In this tractor the draw bar pull is in comparison to its weight and power, higher than any other tractor produced and evenly balanced. By this is meant that the drawbar pull is within a small percentage of its weight in pounds and this means that the weight in proportion to the power is such that the wheels do not dig in under the most adverse conditions.

There is always a limit in flexibility in four wheel tractors working on rough ground but in no field is there ground that will not allow a three wheel tractor to keep all three wheels on the ground.

This is known as the three point suspension theory which so many manufacturers have striven for but failed to achieve because they have put a very light single wheel in front which exert a very light pressure at any time and is completely off the ground in a hard pull be-

cause of the action of the driving torque on the back axle relieving the front wheel of the proportion of the static load.

This tractor from whom the farmers in our country are expecting so much has two wheels in front and one at the back all of which are drive wheels.

Under observations of practical agriculturists the tractor has been tried in snow, wet soil, frosty ground and has not shown the slightest tendency to slip.

The reason is that the weight is balanced with the power and both are transmitted to the ground at three points equally and the fact that there is no differential gear to start one wheel spinning makes all the difference. The omission of these differential gears is what every tractor designer is trying to do as it always takes headlands easily and gracefully.

Of course it still remains to be seen what work will be got out of the machine when it is placed in the hands of the farming public but so far the builder's idea has been to meet the needs of the British farmers as an all-weather, light, and powerful tractor and as a machine which will prove no expensive experiment for the British farmers.

TROUBLE IN THE COOLING SYSTEM

When engines, which normally keep cool even in hot weather or heavy climbing, begin to heat up, suspect the condition of the rubber hose which connects the radiator with the water jacket. There are two such pieces of hose, but it is the top one which usually "goes bad," because it carries the hot water from the top of the engine into the radiator. The bottom hose carries the cooled water either to the pump, if there is a pump, or directly back to the water jacket if the engine uses the thermo-syphon cooling system.

Cars which use pumps for water circulation have smaller pipes and consequently smaller rubber hose connections than those which use thermo-syphon cooling systems. Hot water gradually disintegrates the rubber and cotton of the hose, and when the inner lining of the hose breaks down into a mush, it frequently stops up the hose connection to an extent sufficient to prevent proper water circulation. Replacing such a hose connection can be done in a few minutes by any one who can use a wrench or screw-

driver, and is an operation which does not need the skilled and expensive services of a repairman.

Sometimes engines which cool properly in winter heat up when the first warm days come. In engines of the pump circulation type, this is often caused by a hitherto unsuspected freezing of the pump, which has resulted in broken pump wheel blades. Dismounting the pump and taking it to pieces is the only way to make sure of this trouble. The remedy is a new impeller in the pump.

A CHAIN SAVER

Shift the cross links of your tire chains often. Move them so that they do not depend on the same link of the main chain. The wear and tear on tire chains centers at the links to which the cross chains are attached, and the moving or the frequent shifting of links distributes the wear.

ROPE USEFUL ON TOURS

A useful thing to have in the car on all tours is a half-inch manila rope about 20 or 30 feet long. In the event some of the spring leaves break, it can be wrapped around the axle and spring, and this will save the remaining leaves from breaking before a station or home is reached. If wrapped around the rear tire, it will afford traction in some mud hole, where it would be impossible to fasten the chains. The rope can be used as a tire when the last spare has blown out, and it will save the rim on the journey home.

USE YOUR TIRE CASINGS

Many additional miles of motor-ing can be secured from an old tire casing, even when it has one or two holes, by simply placing a piece of an old inner tube between the section of the casing and the inner tube. This will give a great deal of good service. Try it on the casings you put in the discard pile, and you will be amazed at the decrease in your tire expense this little stunt will make.

Build Now

MONEY SPENT WISELY FOR GOOD
ROADS WILL COME BACK BECAUSE
THE ROAD WILL BRING IT BACK
U.S. DEPT. OF LABOR W.B. WILSON
Secretary

HOW INVENTORIES INCREASE THE PROFITS

Robert Falconer

THE shop of your keenest competitor burns to the ground. The only way that he can arrive at the amount of the loss is by guessing. He can guess fairly accurately, but the insurance adjuster will not settle on the basis of his guess. He makes his own estimates and the owner of the garage after waiting for two months receives a sum considerably less than the actual amount of his loss. He receives this in spite of the fact that he was fully insured before the fire.

Later you have a fire in your own garage. The loss is serious but you are fully insured. Best of all you have taken a complete inventory only a short time and have a copy of it in a safe deposit box at the bank. You show this together with copies of other inventories to the insurance adjuster. He examines them, is satisfied in regard to the value of the property lost and you immediately receive a check and are ready to open for business again at once. Your inventory has enabled you to collect more money from the insurance company and to do so quicker than would have been possible if you had had no inventory.

If you go to the bank for a loan and in addition to showing the banker the amount of business you are doing you will show him a complete inventory of your stock, machinery, equipment, etc., he will after examining it be willing to grant you a larger loan than he would if you did not have such an inventory to show him. Your inventory increases your credit at the bank by just that much.

When you find it hard to meet your accounts in spite of the fact that business is still good you will find that a complete and accurate inventory will go a long, long way towards persuading the credit man of the jobber or the manufacturer that not only should he give you more time in which to pay your old account but also sell you more goods on credit. In brief, inventories amount to exactly the same thing as a little additional capital. They are worth real money in case of a fire. They make it possible to secure bigger loans at the bank and they may prove just as effective in calming the fears of the credit man as real money would prove.

There are two kinds of inventor-

ies, the perpetual and the periodical. The periodical inventory is one taken each month, each quarter, every six months or only once a year and is usually taken whether perpetual inventories are kept or not. These inventories are a careful examination and count of every bit of stock, fixtures, machinery, buildings, equipment, etc., and a valuation of each item in the inventory. Such an inventory if carefully taken is the most accurate and reliable that can be made.

The perpetual inventory is one that gives the stock on hand from day to day. It is a sort of a ledger account of the stock. It is usually kept on cards. One card is used for the record of each item of stock. If we look at the card used for half inch lock washers we find recorded there every shipment of washers received, every washer used on a job or sold and a record of the prices paid for the washers. By checking this up against the actual number of washers in stock it is possible to ascertain how many have been lost or stolen for if there are fewer washers than the balance on the card shows there should be the difference in the number which have been stolen or have been lost. The fact that they have not been charged up on any job or no money has been received for them means that they are a loss to the firm.

The frequency with which inventories should be taken depends upon many conditions. Where no perpetual inventory is kept it is necessary to take periodical inventories more frequently than it is where a perpetual inventory is kept. In fact there are cases where no complete inventory is taken in connection with the perpetual inventory but a perpetual system of checking used instead.

The most successful retail establishments usually take inventories once a month. This system prevents the accumulation of dead stock, means that there will always be a recent inventory on hand to use in cases of emergency and prevents numerous leaks in the business that would remain concealed and go on increasing if it were not for these frequent inventories. Where the fire hazard is high and high premiums are paid on the fire insurance, it most certainly will pay to take inventories as often as once a month. In case of fire the extra amount collected from the insurance companies will more than make up the cost of taking these

inventories. Be sure also to keep a copy of the inventory in a safe deposit box in the bank or some other safe place. Don't put total reliance upon the office safe. Even if the papers in it are not destroyed you have to wait until the safe can be recovered before securing them. If they are in a safe deposit box you can get them at once.

Where the business is growing rapidly there is always a greater chance of making mistakes or of suffering losses through the carelessness or dishonesty of employes than is the case where the business is growing slowly. Safety in the case of rapid growth requires very frequent inventories. Once a month is none too often. If they are not taken this often they may show that the business has been ruined when they are taken.

There are two ways of taking a periodical inventory. Where a shop is open all the time only one of these can be used. Where it closes at night either system will prove workable. One system requires overtime and the other can be taken during working hours.

The working hour system is sometimes called the tag system and is taken in the following manner. One man or if necessary more than one man goes over all the stock counting the pieces in boxes and bins and examining all machinery and equipment. When he has counted the number of pieces or examined any machine or equipment in the plant he tags it with a tag on which are notations showing the quantity on hand or the condition of the machine or equipment. This work is started early enough so that everything in the plant can be tagged before stock taking day. When anything is placed in or removed from stock bearing a tag the information is entered on the tag. On the day the inventory is to be dated all the tags are gathered up. It is then a simple matter for the bookkeeper to make up the inventory sheets.

To make a success of a perpetual inventory it is necessary to have the stock room separated from the shop and in charge of some one who will not fail to make the necessary entries. The person who keeps the books and looks after the office can do this or if the business is large enough to warrant the expense a special stock clerk can be placed in charge.

Enough cards must now be secured so that a single card can be

BENCH CATCH ALL TRAYS

Old worn out farm machinery collects around some blacksmith's shops and the industrious smith uses the material for repairs to other machinery. This sketch

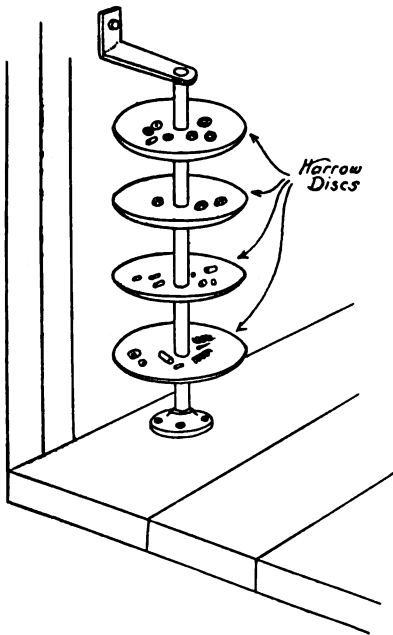

shows how one shop made several handy bench catch alls from some old harrow discs. The discs were spaced apart with short pieces of old pipe and secured to the wall at the top by a small bracket. Another use that this shop has made of the old discs was the making of farm call gongs for the ringing sound of the discs were excellent and many farmers were glad to purchase the improvised call gongs.

given to each item of stock. Cards six by four inches in size are usually the most convenient for this purpose and it will probably be possible to secure stock cards with the necessary ruling.

Across the top of the card write the name of the item a record of which is to be kept on the card. In the ruled columns below keep a complete record of all the stock used or received and the prices paid for the stock. The column heading for such a card can be something as follows: Date. Purchased From. Number or Amount. Price. Date. Job. Number or Amount. Balance on Hand. The keeping of such an inventory is made easier if job cards are used on each job. On these cards there should be space for recording all the time put upon the job, as well as all the material used. Where such cards are used,

A MULE AHEAD OF THEM

When the town of Blessing was being born on Jack-of-Spades ranch land in Texas, a man of two trades built a shack near the railway station. On one side he installed a barber chair and its accessories and on the other a forge and anvil. One day a Northern tourist settled himself in the chair and asked to be shaved in a hurry. With an apologetic glance at the other side of the shop, the proprietor replied:

"I'm sorry, suh, but theh's a mule ahead of yuh."

Reminiscent of this in an editorial by the owner of the Vanceburg, Ky., Sun, who, it seems, also pursues the no less noble calling of blacksmith and horseshoer.

"We desire to make it plain," he writes, "that the editorial department of the Sun is entirely separate from the business and is not to be controlled by a little advertising or job work as some may seem to think. We are not sorry for any editorial statement we have so far published and should financial stress overtake us, we will, God willing, either sell the Sun or cease its issue and labor thereafter at the village smithy."

There's a man who has nailed his flag fast! If the brave craft "Sun" goes down, her captain goes down with her; not to perish, praise be, but to strike out with lusty strokes for her sister ship, "Smithy," which is standing by to rescue.

Let advertisers and job-work patrons who seek to control the editorial policy of the Sun beware. There's a mule ahead of them.

the inventory cards can be posted from the job cards.

Of course such an inventory will eventually become of little value as an inventory unless checks are made with the stock that is actually on hand. This checking can be made periodically by taking a complete inventory or it can be made perpetually by checking up part of the stock every day. One large part and service station of an automobile manufacturer has a man checking the cards daily. Each morning he takes a certain number of cards or copies of the

cards and checks them against the stock. In one or two weeks he has covered the whole stock and is ready to begin over again. In this way the cards are constantly being checked and they cannot be very far wrong as a whole. The usual method, however, is to check the cards up by means of a complete special inventory.

The perpetual inventory since it keeps a record of every part of every item of stock tends to decrease the loss due to spoiled, lost or stolen parts. Some machine shops were forced to adopt this method of inventorying their stock because they had good reason to suspect that certain of their employees had used enough stock to build machines of their own, a few of them even building automobiles. After the perpetual inventory system was adopted there was a very marked falling off in the number of machines that the employes built at their homes before and after working hours.

This cutting down of unnecessary waste, the greater expansion of the business which is made possible through the increased credit at the bank, at the jobbers and with the manufacturers, and the closer touch which is given with the business, makes the keeping of inventories worth far more to the business than it costs to keep them. It will be found to be the case that those concerns which enjoy the greatest prosperity for any great length of time are those which keep the most careful inventories. Inventories to a business are just as necessary to success as the full gasoline tank is to an enjoyable automobile tour.

TIRE FAKERS BARED

"A favorite trick of the tire faker is to announce very low prices on standard tires," says a bulletin of the Associated Advertising Clubs of the World, "Then in shipping them send an unknown make along with a letter to the effect that he is just out of the make wanted in the size ordered, but he is doing the customer a great favor by shipping another (of unknown quality) which usually is said to sell regularly for more than the tire ordered, etc. A price list, printed for the purposes of the substitution scheme, often accompanies the letter, and the unknown tire that has been shipped is shown on the price list, priced as indicated in the letter."

WHY FARM WAGON TREADS HAVE BEEN STANDARDIZED



The old 60 inch wide-track wagon jolts and bumps along on the ridge vainly trying to make a track of its own. The result is broken axles sprung wheels, loose spokes and heavy draft. The auto suffers also because its tires are chewed and torn by the stones and clods which are tumbled into the rut by the wide wagon.

WHY WAGON TREADS HAVE BEEN STANDARDIZED

EARLY automobiles were built with both wide and narrow tracks. Very soon this was found unsatisfactory and five years ago the tread of all automobiles was standardized on the basis of 56 inches from center to center, now called "auto-track."

The average automobile makes 3,000 miles a year. The average wagon travels less than 300 miles a year. In rainy weather on soft roads, of which we still have thousands of miles, the constant stream of autos forms two deep wheel ruts, 56 inches apart, and throws up high ridges on each side. The farm wagon with a wheel tread of 60 inches (known as "wide track") does not fit this auto-track, but bumps along trying to make its own track and failing because there are so many more automobiles than farm wagons.

This results in rough riding and heavy pulling. Worse still, it causes many broken axles and wheels, for when the wagon is heavily loaded and slips off the ridge into the rut forcing the other wheel out of the opposite rut, the additional strain on the axle and twist on the wheels caused by squeezing them together at the bottom is likely to break either one or the other. Investigation has proved that since autos became common, more wide-track wagons break axles and wheels



There are ten times as many automobiles as farm wagons, and an auto covers ten times as many miles as a wagon. Therefore, on soft roads of which we still have thousands of miles, the road tracks or wheel ruts are established by the automobile with its 56 inch standard tread.

than any other type of wagon.

While the wagon suffers from broken axles and broken wheels because of the difference in track, the auto suffers another way. Look at the tires of any car that travels regularly in a wide track wagon country. They will be chewed and cut and gouged because the wide track wagon which does not fit the auto track pushes the stones and clods into the ruts, thus causing the damage to the automobile tires.

With the production of automobiles and motor trucks reaching

Today the 60 inch wide track wagon is out of date on 80% of the roads. Autos and trucks are increasing so rapidly that the 60 inch wide track wagon will soon be a hopeless stranger with nowhere a road track which it will fit. As long as it is used, a wide track wagon will prove an expense and an inconvenience.

hundreds of thousands annually, it means that our country roads in even the most remote sections will be controlled by motor vehicles. It is not treating the farmer square to continue making wide-track wagons which do not fit the established road track, because such wagons cost the farmer more than they are worth in heavy, rough riding, and broken parts. Therefore the foremost wagon manufacturers have discontinued the wide-track wagons because they realize that the farmer is demanding a wagon that will follow the trail made by his automobile and motor truck.

Wagon manufacturers do their best to give the axles and skeins the proper set and gather in order that both will work in harmony to produce a light running gear, but the accomplishment of this depends on a very important factor, namely, that the wagon follows the tracks in the road. Otherwise all parts bind and the wagon pulls hard.

When a farmer buys an automobile he never gives its wheel tread a thought because he knows all autos have the same track. Yet if he would stop to think about it he would not want a wagon with a different tread from his auto because he realizes at once that both the automobile and the wagon will suffer.

Today the 60-in. wide-track wagon is out of date on 80 per cent

of the roads in the United States, and at the rate autos and trucks are increasing on the country roads, the 60-inch wide track wagon will soon be a hopeless stranger because there will be nowhere a road track which it will fit. A wide-track wagon will prove an expense and inconvenience as long as it is used, while a standardized auto-track wagon will fit the road wherever it goes.

The automobile is standardized as to track and it controls the road because of its numbers. Why should not farm wagons which must follow the auto track, and which no longer have any control of the road, be standardized, also using the automobile wheel tread as a basis? This is merely common sense.

A standard track for farm wagons and a standard wagon box width have long been needed among the farmers of this nation. The farmers are now demanding it. Therefore no manufacturer who has his customers' interests at heart will attempt to force him to take a wagon that his reason tells him is out of date and inconvenient.

The standardized wagon places the farmer on an equal basis with his neighbors. It puts him in a position to build up-to-date hay racks, hog racks and other special bodies as necessity may demand, knowing that no matter whose wagon he may buy in the future, his equipment will fit. He can move from one part of the country to another or put his wagon up for sale, knowing that the standardized auto-track wagon will bring a better second-hand price than an out-of-date wide-track wagon.

The standardized auto-track wagon is not the individual hobby of anyone. It is the logical outcome of the steadily increasing number of automobiles and motor trucks. It is a compromise between the old style wide-track wagon of the south and the old style narrow track wagon of the north. It is a wagon that is unquestionably in line with modern progress.

ANOTHER REPAIR OF A BROKEN CARBURETOR GLASS

In reading the June number I see where Mr. Geo. H. Eastman made a very ingenious repair on a carburetor that had a glass float chamber. It reminded me of a repair that I had to make on one of the same kind. This was a touring party and they drove into the garage for some oil and air and to

make some adjustment in around the carburetor. The light was not very good and the man that was doing the job thought that his wrench was on the nut he was tightening. It wasn't — when he pulled the wrench slipped and struck the glass. This did not stop at a hole but broke all the glass out. Of course it was impossible to repair the broken glass. The owner was some put out and of course had reason to be. To get a new glass would take two days. We tried to find an oil cup glass that would fit but all were too small. One man suggested getting a bottle of the right size and cutting it off and using it. This would have been alright but we found that the bottles were all a little too large

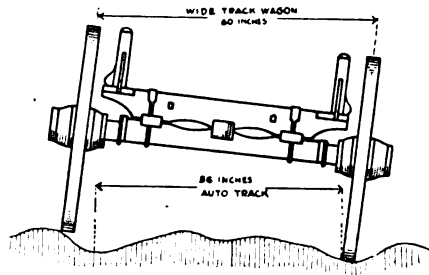

The old style wide track wagon with its 60 inch tread is now displaced by the up to date auto track wagon with the standard 56 inch tread.

or small. The carburetor will work just as well if the float chamber is not of glass. In our junk pile were some short pieces of brass pipe, just about the same thickness as the glass that was broken. I took a piece of this and sawed it off about a quarter of an inch longer than I needed and caught it in the lathe chuck and faced off both ends so they were perfectly square and just as long as the glass. I found that the pipe was a little too large to go into the recess that the glass set in and so had to turn it down a little. The gaskets were all in good shape at the top and the bottom of the glass. We put some shellac on the ends of the brass pipe, put it in place and tightened down in good shape. The man that owned the car was about as pleased as anyone could be. The boss charged him for the time that it took to do the job and before he left he slipped a five spot to myself and the fellow that helped make the repair. He called at the garage the next year and he had the same carburetor with the brass float chamber. He said with that he was not afraid to hit around in there

with any wrench or hammer and as long as it worked he would leave it.
M. H. George.

AUTO PRICES BOOSTED

Contrary to general expectations reductions in car and truck prices made in a few cases when war pressure let up have failed to be followed up by the makers with other price reductions and increases have been made in a number of instances. Other boosts are on the way and the first of August will probably see increases of a hundred dollars or so tacked on to present prices of some makers. The prices of some cars having been guaranteed to August 1 will probably show a change for the worse on or about that date.

Among companies that have already put increases into effect are the Maxwell, Chalmers, Studebaker, Hudson, Essex, Cadillac. Other companies suspected of having similar designs are Chevrolet, Hupmobile and Paige.

Tire makers were considering another price reduction following the average 15 percent reduction of some time ago but this plan has been given up for the present.

Labor and material costs are claimed to be responsible for these conditions and no reduction in automobile prices can hardly be looked for until present conditions simmer down.

WATCH THE SCRAP

In doing any job in which you find that a considerable portion of material has to go to the scrap heap after the job is finished, it is a wise plan to figure out just how this wastage of material may be avoided. Is there any other size of stock that could be used more economically, or is there any other way in which you could do the job so as to save the material you have over? There is always another way of doing even the most simple operation in forging, and in many cases the "other way" is the profitable way. Materials of all kinds are too high in price these days to waste any that can be utilized.

"All things come to him who waits,"
But here's a rule that's slicker:
The man who goes for what he wants,
Will get it that much quicker.

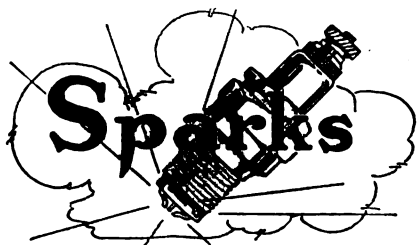

No man is happy unless he thinks he is.

The grouch that poppa has on when you ask him for money, young lady, is not a marker to the grouch hubby will have on when you ask him for money after you are married.

A man doesn't admire the other man's wife because she is prettier than his own wife. He admires her because she is the other man's wife.

Love is something that impels fool men to give up bachelor quarters for better halves.

It costs money to sow wild oats. But there never has been a time when the supply didn't exceed the demand.

After a man gets married and settled down he often wonders how she managed to keep so quiet when he was courting her.

A dollar in the hand is worth two in the pocket that has a hole in it.

Even when people frankly marry for money they may be disappointed in love.

Virtue is its own reward. An evil tongue always gathers together the largest audience.

All flesh is as grass, in spite of which fat people may not be as green as they look.

It's a good thing that the wind is tempered to the shorn lamb, who is generally trying to raise the wind.

It is one thing to transform a lover into a husband, but it's quite another matter to turn a husband into a lover.

You can't always size up a vulgar display of wealth. Many a girl wears her heart on her sleeve just to prove she has one.

Eggs are dropping, but they are not coming down hard enough to break.

The man who wants but little here below ought to be satisfied with what he gets.

A girl never realizes the full value of a fellow's love until she sues for damages. Hope springs eternal in the human breast, and even in April we are hopeful of spring.

When a wedding takes place in the nave of a church would you call it the nave of hearts?

The fact that this is a hard world is perhaps why the average man wants to be let down easy.

No, Maude, dear; the ability to nurse a grievance would scarcely get you a job in a hospital.

Misery loves company. If there were were more trolley cars during the rush hours there would be fewer strap-hangers.

It isn't so bad to believe only half you hear, provided you select the right half.

No, Maude, dear; sea weeds are not designed as mourning for sailors' widows.

Economy—A theory that a person is always going to put in practice tomorrow.

Most things are expensive out of season, but venison is always deer even when it is in season.

THE YANKEES ON THE MARNE

Oh, the English and the Irish, and the 'owlin' Scotties, too,
The Canucks and Austryleyuns, and the 'airy French Pollu—
The only thing that bothered us a year before we knew,
Was 'ow in 'ell the Yanks'ud look, an' wot in 'ell they'd do.

They 'adn't 'ad no trynein' they didn't know the gyme.
They 'adn't never marched it much—their shooting was the syme;
An' the only thing that bothered us that day in lawst July
Was 'ow in 'ell the Line 'd 'old if they should run aw'y.

Them leggy, nosey new 'uns, just come across the sea—
We couldn't 'elp but wonder 'ow in 'ell their guts 'ud be.
An' the only thing that bothered us in all our staggerin' ranks
Was wot in 'ell 'ud 'appen w'en the 'Uns 'ad 'it the Yanks.

My word! it 'appened sudden w'en the drive 'ad first begun;
We seed the Yanks a'runnin'—Gad blimy! 'ow they run.
But the only thing that bothered us that seed the chase begin.
Was 'ow in 'ell to stop 'em 'fore they got into Berlin!

They didn't 'ave no tactics but the bloody manual,
They 'adn't learned no horders but "Ooray!" an' 'Give 'em ell!
But the only thing that bothered us about them leggy lads
Was 'ow in 'ell to get the chow to feed their "Kamerads!"

So we're standin' all together in a stiffish frin' line,
If anyone should awsk you, you can say we're doin' fine.
But the only thing that bothers us—an' that don't bother much—
Is 'ow in 'ell to get the dirt to bury all the Dutch.

Gaw's trewth! it's rotten fightin' that all our troops 'as seen,
The 'Un's a dirty pl'yer, becos 'e's alwus been.
But the only thing that bothers us in 'andin' 'im our thanks
Is 'ow in 'ell we'd done it if wercn't fer the Yanks.

Oh, the English and the Irish, an' the 'owlin' Scotties, too,
The Canucks and Austryleyuns, an' the 'airy French Pollu,
The only thing that bothers us don't bother us no more:
It's why in 'ell we didn't know the Yankee boys before!

Emerson Hough

You never can tell. Many a man who is too proud to beg will accept an office as the gift of the people.

Trouble makes a man shamefaced. Even a lobster blushes because of its inability to keep out of hot water.

The optimist was suffering from insomnia. "At least I am glad it isn't toothache that is keeping me awake." he rejoiced.

The turtle, getting in the soup, demonstrates that the race is not always to the swift.

The girl who marries a title nowadays can stay at home and pick out a military one.

The man who writes his own obituary disproves the theory that dead men tell no tales.

Every man to his trade. Inspiration is necessary to the poet, expiration to the undertaker.

Man wants but little here below, but he has to have a fresh supply of it every once in so often.

We are still taught that this is the land of the free, in spite of the fact that our hands are tied.

Eternal vigilance is the price of liberty, and even that is going up.

The man who hides his light under a bushel has to pay the gas bill just the same.

Women want the best of husbands, when they ought to be satisfied to get the best of one.

Physical culture is a good stunt. It takes a mighty strong man to carry out his good intentions.

Just about the time we think we are about to make both ends meet somebody moves the ends.

Shad roes by any other other name would smell as fishy.

If every lie could be nailed iron would soon become as scarce as radium.

You never can tell. Many a man outlives his usefulness who never had any.

Some people are so tender-hearted that they won't even tell the truth if it hurts.

It isn't absolutely necessary to be a crank in order to get things coming your way.

Industry is a game law constantly violated by those addicted to the popular sport of killing time.

Every man to his trade. Even in starting a poultry farm it is necessary to know the lay of the land.

Many a political job suggests that there isn't a whole lot of difference between a sinecure and a rest cure.

Never look a gift pipe in the mouth-piece.

The day may come when even the prohibitionists will agree that an ounce of prevention may have been worth a pound of cure.

A woman's idea of refinement is to be tall and thin.

Unrequited love soon acquires a job lot of wrinkles.

It's always advisable for a poor liar to tell the truth.

Every woman would live long, but no woman would grow old.

Many a man who knows what is right lacks the courage to do it.

A bird in the hand is permissible if you have no knife and fork.

Introducing a happy man to a pessimist is like shaking a red flag at a bull.

The good business man and the business man who is good are not necessarily synonymous.

If you would have others think well of you set an example and think well of yourself.

And some church members seem to think it is up to the minister to make good for the entire congregation.

Many a deluded man who thinks he is marrying a woman discovers later that the woman married him.

Ambition is a wonderful incentive to climb. Even the steeplejack may a-spire to higher things.

METAL SILVERING PASTE

A composition suitable for silvering such metals as german silver, brass, copper and copper alloys and which when applied to such metals deposits a bright durable coating on the objects, should be prepared by combining the ingredients named below and in the proportions specified:

- Silver chloride1 ounce
- Potassium chloride3 ounces
- Ferric chloride2 ounces
- Stannic Potassium chlorid.....1 ounce
- Calcium chloride.....2 ounces
- Kaolin, (U. S. P.).....8 ounces
- Levigated chalk2 ounces
- Water11 ounces

Place all the chlorides together with the kaolin and levigated chalk in an ordinary flour sifter and sift through about three times in a bowl to insure of the ingredients being thoroughly mixed. Next, add the water in small quantities at a time and stir with a wooden stick until a pasty mass is formed. The mixture is then ready for use. It is advisable to pack it in small glass or porcelain jars or ointment pots, similar to those used for salves and toilet creams. Metal containers should not be used. If desired, the powders can be mixed and kept in a bottle or jar in a dry condition, the water being subsequently added at the time the mixture is required for use.

This preparation can be applied to the metal objects to be silvered by means of a soft bristle brush or chamois skin which has been previously dampened. Allow to dry for about ten minutes and then polish with a strip of dry flannel.

ALUMINUM SOLDER

The object of this process is to provide an alloy or composition of metals, which when subjected to a proper heat will fuse and unite with the surfaces of aluminum metal.

To prepare this solder, the metals noted are used in the following proportions:

- Phosphor tin5 ounces
- Zinc9 ounces
- Aluminum6 ounces
- Tin54 ounces

Mix the metals as follows. First, melt the zinc in a clay crucible, then add the tin and phosphor tin in small pieces, and finally the aluminum. The whole mass should be well heated, and then poured into metal moulds to solidify. The melting range in degrees Centigrade of this alloy is between 300 and 400.

In applying this solder, scrape

the part clean with a file or emery paper; heat the soldering iron very hot and hold it upon the aluminum article to be repaired long enough to get the part to be soldered sufficiently hot to make the solder flow. It is always better to use two soldering irons while soldering, so that they can be changed frequently to keep the solder hot. The soldering irons used, should if possible be heavy ones so that they will retain the heat as long as possible. For soldering heavy aluminum articles it is a good plan to solder with a blow-pipe so as to impart a high heat to the work and for more quickly melting the solder. After the solder melts it is moved or stirred about with a light tool, and at the same time, the flame is directed with the blow-pipe upon the work and the solder. The solder then unites with the surface of the work and in cooling forms a firm and solid joint.

HAND CLEANING PASTE

A good hand cleaning paste should have incorporated a satisfactory detergent or cleaner of sufficient strength to attack, grease, dirt, dyes or inks, and at the same time should not contain an excess of alkali to such an extent as to injure the skin. The green soap which forms the base for this paste, together with the ammonia water and oil of turpentine embody all the features mentioned above. A good abrasive or dirt cutter is very essential and pumice stone (finely powdered) is the best material that can be used. The scenting oils are added to impart a pleasing odor to the preparation. To prepare use the following ingredients:—

- Soft soapp90 ounces
- Ammonia water6 ounces
- Turpentine sufficient to form a stiff paste
- Finely levigated pumice stone..30 ounces
- Essential oil (either oil of wintergreen or oil of sassafras).....3 ounces

Mix the soap and ammonia water and add the turpentine. Heat the mixture over a water bath by using a double kettle. Allow the mixture to heat until a jelly-like mass is formed and while still heated, add the pumice stone and stir well while adding, so that it will incorporate thoroughly without forming lumps. After all the pumice stone has been added, continue to stir for five minutes, at the same time, dropping in the essential oil. Set aside to cool for from five to ten minutes and while still syrupy, pour into containers.

Benton's Recipes

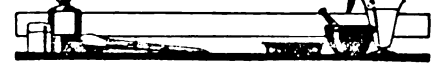

Waterproof Paint for Plaster—To make waterproof paint for plaster get some mica plates, bleach them by fire boil in hydrochloric acid, wash and dry and reduce to a fine powder; then mix with sufficient quantity of collodion to make it run from the brush. Apply with ordinary paint brush.

Varnish for Iron Work—To make a varnish for outdoor wood and ironwork, dissolve in about 2 pounds of tar oil ½ pound of asphaltum and a like quantity of pounded rosin; mix hot in an iron kettle, care being taken to prevent any contact with the flame. When cold the varnish is ready for use.

Steel Blue Enamel—A steel-blue enamel suitable for applying to steel and also others metals to give them a steel-blue polished surface, may be made in the following way: Dissolve 1 part of borax in 4 parts of water. Macerate 5 parts bleached shellac in 5 parts of alcohol. In a small quantity of alcohol dissolve some methylene blue of sufficient amount to give the color desired. Heat the first or watery solution to boiling, and while constantly stirring add the alcoholic solution. Stir until all the lumps are dissolved, and then add the blue solution. Before applying, the surface to be blued should be cleaned and brightened with emery cloth. The enamel is best applied with a soft brush. The solution may be put into a bottle and set aside for future use, provided the bottle is securely corked.

To Improve the Color of Shellac Varnish—Occasionally the shellac varnish used by the pattern maker for varnishing very nice patterns will seem to lose its clear, amber tint. It is frequently the case that the jar is cleaned out and a fresh lot dissolved. This does not always cure the trouble. Any desired depth of tint may be readily obtained by the addition of a small quantity of gamboge previously dissolved in a small quantity of alcohol. It should be kept on hand for this purpose.

Cold Tinning—Block tin dissolved in hydrochloric acid with a little mercury forms a very good amalgam for cold tinning; or, 1 part of tin, 2 of zinc and 6 of mercury. Mix tin and mercury together until they form a soft paste. Clean the metal to be tinned, being careful to free it of all greasiness. Then rub with a piece of cloth moistened with hydrochloric acid and immediately apply a little of the amalgam to the surface, rubbing with the same rag. The amalgam will adhere to the surface and thoroughly tin it. Cast iron, wrought iron, steel and copper may be tinned in this way. Those who find it difficult to make soft solder adhere to iron with sal ammoniac, will find no difficulty if they first tin the surfaces in this manner and then proceed as with ordinary tin plate.

Welding Steel to Wrought Iron—Pulverize and mix with water 6 parts by weight of brax, 2 sal ammoniac, 1 of prussiate of potash and ½ part of resin. Boil the mixture, stirring it constantly, until it forms a stiff paste, which is allowed to harden over the fire. When cold, pulverize and mix with it 1 part of wrought-iron filing free from rust. In using it scatter the powder upon the red hot pieces and liquify it over the fire.

License Plates

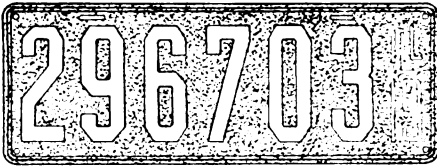

ILLINOIS—White on light brown. Registration according to h. p. Less than 10 h. p. \$4.50 10-25 h. p. \$6; 25-35 h. p. \$9; 35-50 h. p. \$16; 50 h. p. or more \$20.



PENNSYLVANIA—Red on Black—Less than 20 h. p. \$5; 20-35 h. p. \$10; 35-50 h. p. \$15; 50 h. p. or over \$20. Makers number stamped in keystone.



OREGON—Black on orange. Fee according to h. p. to 26 h. p. \$6; 26-36 h. p. \$10; 36-40 h. p. \$15; over 40 h. p. \$20.

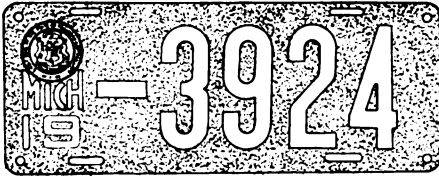

MICHIGAN—White on brown. Registration 25 cents per h. p. and 25 cents for each 100 pounds.

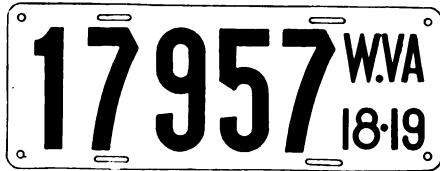

WEST VIRGINIA—White on black. Ten dollars for first 2,000 pounds or less, each additional 100 pounds 25 cents.



VIRGINIA—White on black. Forty cents per horse power.

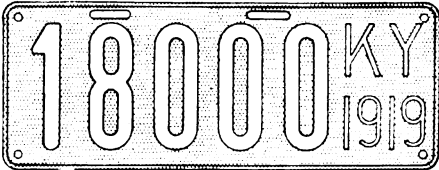

KENTUCKY—White on bright green. According to h. p. Less than 25 h. p. \$6; 25-50 h. p. \$11; more than 50 h. p. \$20.



MARYLAND—Black on white Passenger cars using pneumatic tires 60 cents per h. p. or fraction. Minimum fee \$10.



RHODE ISLAND—Black on white—Fee based according to h. p. from \$5 to \$25.

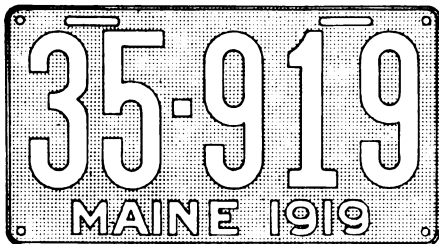

MAINE—White on maroon. Fifteen h. p. or less \$5; 15-35 h. p. \$10; 35 h. p. or over \$15.



NEW HAMPSHIRE—Black on white. According to h. p. from \$10 to \$40.

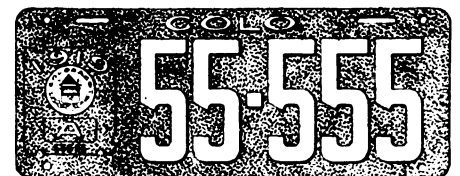

COLORADO—Aluminum on dark brown. Cars in three classes A, B and C according to fee paid which is \$10, \$5 and \$2.50 respectively. The same plate is held for five years, a new slide plate being issued each year which is attached at the left of plate.



CONNECTICUT—Black on white. Registration according to H. P. Minimum fee \$5 for 1-10 h. pp. and 50 cents for each additional h. p.



ARIZONA—White on black. To 25 h. p. \$5; 25-40 h. p. \$10; over 40 h. p. \$15. Recent amendment to motor laws makes payment of personal property tax necessary for every person applying for motor vehicle license.

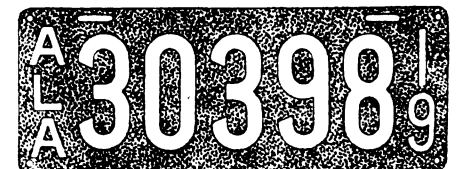

ALABAMA—White on Dark Green. Registration according to h. p. from \$7.50 to \$20.

m all the States



INDIANA—White on Black. Less than 25 h. p. \$5; 25-39 h. p. \$8; \$40-49 h. p. \$15; 50 h. p. or over \$20.



NEBRASKA—Black on green. Fee based on weight of car, being \$10 for the first 2,000 pounds and 50 cents for each additional hundred pounds.

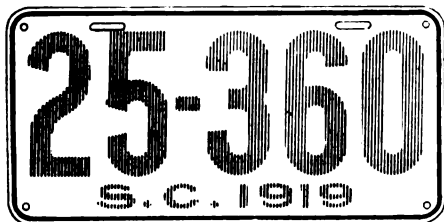

SOUTH CAROLINA—Dark blue on white. License fee according to horse-power of car—25 cents per h. p.



NEW YORK—White on black. 25 cents for each h. p. plus 40 cents for each \$100 of the list price of car fully equipped for first three years. During 4'th and 5'th years this will drop to 20 cents for each \$100 of list price and 10 cents for the 6'th year on. The 25 cents per h. p. remaining constant.

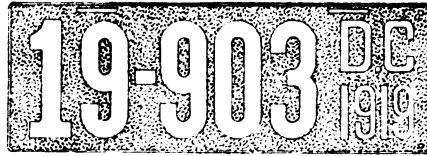

DISTRICT OF COLUMBIA—White on Olive Green. Fee \$2.

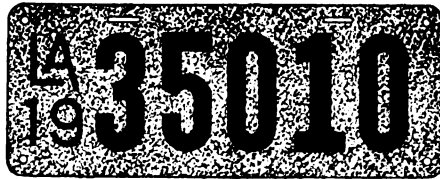

LOUISIANA—Black on pea green. Twenty-five-cents per horse power. Minimum fee \$5.



WYOMING—Black on light green. Fee by quarters, \$5, \$4, \$3 and \$2.

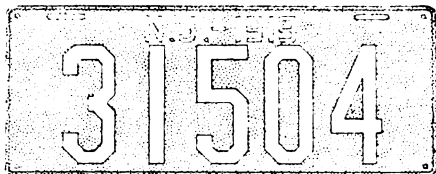

NEW JERSEY—White on French gray; -10 h. p., \$4.50; 11-29 h. p. \$7.50; 30 h. p. and over \$15.



DELAWARE—White on blue. Fee is \$2 for each 100 pounds or fraction.



NEW MEXICO—Black on white. Fee based on h. p. from \$6 to \$12.



VERMONT—Blue on buff. First year registration \$1 per h. p. Second year, 75 cents per h. p. and third year and thereafter 50 cents per h. p.



UTAH—White on dark green. License fee to 25 h. p. \$5; 25-40 h. p. \$10; more than 40 h. p. \$15.



TEXAS—White on black. Registration fee 35 cents per h. p. Texas has so-called "permanent" system, whereby a car remains registered under the same number each year, a distinguishing seal being issued each year to attach to car as an evidence of license renewal.

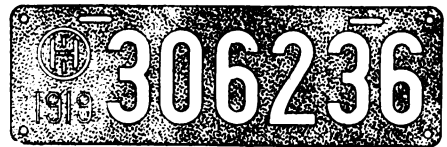

OHIO—White on dark maroon. Fee \$5.



MISSOURI—White on dark blue. Fee \$4 to \$24 according to h. p.

(Continued to page 283)

CRANK cases get broken in many different ways and the fractures are located in various inconvenient corners and angles of the castings. Each fracture presents a different problem in welding, each requires a little different treatment in heating, handling and melting. Some crank cases require to be heated all over; others may be welded practically cold; some have to be heated only partially; some require the welding in of patches; others are merely cracked; some have only one break while others have as many as six or seven and although each may present a different problem each and all require certain treatments that are the same for all. It is obvious that all of these things cannot be discussed in one article so that we will attempt to take up but one herein.

The crank cases are usually made of one of three materials, viz.: cast iron, steel or aluminum. Either of these requires special treatment in the welding process according to its individual peculiarities. A comparative discussion of the welding of the three kinds is also beyond the scope of this article. Therefore, a quite common aluminum case will be taken up at this time; and since aluminum is usually considered difficult to weld it is probably best to discuss it first. In this connection it may be said that different locations of the fracture in aluminum crank cases present different problems in heating and welding, probably more than in castings of other metals.

Aluminum has a high rate of expansion and contraction which, combined with a low melting point makes it more difficult to weld successfully. Another thing that stands in the way of easy welding is the fact that aluminum oxidizes so readily. It will not flow together like other metals any time, in fact, it tends to creep apart at the joint. It might be said two pieces of melted aluminum repel each other. This is due to a thin skin of oxide which forms on the surface of melted aluminum almost as soon as it reaches the molten stage. At least within a very short time afterward. This oxidization comprises the chief difficulty to be overcome when an attempt is made to weld aluminum. It is probably the cause of more defective welds than

Welding an Aluminum Crank-Case

DAVID BAXTER

any other factor in the welding process, even expansion and contraction. There are several things to which oxidization is due, aside from the peculiarities of the nature of aluminum as a metal. One of these is the presence of oxygen in the welding flame, especially an excess of it. A welding flame carrying more oxygen than is needed to consume the carbon will cause aluminum to oxidize rapidly, especially if the oxygen is much in excess. Or, in other words, aluminum has an affinity for oxygen of the welding flame. Therefore, it is essential to be careful about regulating the welding gases to the flame. A neutral flame should be employed

aluminum oxidizes when exposed to the action of the air which is one of the little known causes of trouble for many welders. Aluminum filler rods that have been on hand for some time get covered with a coating of oxide which will cause trouble in welding without the welder being able to locate its source unless he happens to be familiar with the fact. Therefore, it may be wisdom to keep but a small stock of aluminum filler on hand. At least it is well to scrape the filler rods before using them, especially if coated with a white substance.

The action of the oxygen from the air upon melting aluminum may be averted to some extent by spreading the outer flame of the torch across the weld in a manner intended to prevent the air from reaching the weld. Intercept the oxygen of the air by a strata of flame. Also, the danger of oxygen from the atmosphere may be lessened by welding rapidly. Rapid welding gives a chance to get the metals melted and mixed before the oxygen attacks it to a great extent. For instance, in welding patches, flow as large a mass of metal across the patch as possible at one time. Have as few edges to be joined as possible. To mix or join the edges a system of puddling is usually employed. Puddling consists of paddling or prodding the melting edges together. This breaks up the film of oxide causing it to float where it may be floated or scraped away, thus allowing the metals to flow together.

Still another method of preventing oxidization is the using of a good deoxidizing flux, of which there are several on the market today. The office of this flux is to prevent the oxygen from attacking the molten metal. The common kind burns on the surface of the weld and takes up any oxygen coming near it, both of the air and the flame. It should be applied frequently throughout the welding process. Some kinds are applied by sprinkling over the surface of the weld, some by applying in paste form before starting to weld and, perhaps the commonest way, by dipping the melting end of the



FIG. 1—LOCATION AND CHARACTER OF THE BREAK

in any event, although expert welders employ a flame having a slight excess of acetylene gas. At any rate no attempt should be made to weld aluminum with a flame carrying more oxygen than acetylene.

Another source of trouble with oxide is the atmosphere. Melted aluminum absorbs oxygen from the air surrounding the weld. Perhaps it is more correct to say that the oxygen of the atmosphere at-

tacks the metal. This is going on all the time even when the aluminum is cold but more severely when the metal is melting. Cold

filler rod in the flux powder at frequent intervals as the weld is made.

Once he has mastered the art of preventing oxide from forming the torch operator should endeavor to understand expansion and contraction as it acts upon aluminum castings. Like other metals it expands upon being heated and contracts upon cooling. The quicker it is heated and cooled the quicker



FIG. 2—METHOD OF COVERING, HEATING AND WELDING

will expansion and contraction act and the greater the danger of cracking. In simple words expansion enlarges the metal and contraction reacts to cause the casting to return to its normal state. As soon as the heating commences the metal starts to enlarge then contracts as the cooling sets in. It is obvious then that the heavy sections of a casting heat last and therefore expand slower; also cool last and contract slower. When the light section has reached normal the heavy section is still contracting and will probably crack at the juncture of the light and heavy parts; this happens where nothing has been done to counteract the actions where no attempt is made to control or regulate expansion and contraction. Generally speaking there are two ways to do this, one is by regulating the heat; the other by concentrating or localizing it. In the first instance an endeavor is made to have all sections heat and cool alike by suitable arrangement of the heating devices and by forcing the light parts to remain hot longer while allowing the heavy ones to cool. A variation of this idea is to heat the whole casting alike and cover it up so it will cool very slowly after it is welded. The radiated

heat under the covering tends to keep the heat even throughout the whole thing so that all parts reach normal at the same time. This method is also successfully combined with the localizing method. The localizing method consists of endeavoring to prevent the heat from being conducted to other than the small welded section. The heat is confined to a small area on each side of the weld, the idea being to heat so small a part that the contraction will not be great enough to harm the job. If the welder is a skillful operator the latter method may be employed on many classes of work with good results. A thoughtful mechanic can devise many little ideas to work in conjunction with the localizing method. One of which will be explained in the instruction for welding the crank case illustrated herein. A complete set of welding instructions will be given for the way the work was done on this particular job. There are probably other ways of doing this work and maybe some of them are better, however, the average welder will find the following described method will produce satisfactory results if carefully followed on similar castings.

The Job.—First a brief description of the job: it was an aluminum crank case of a Rco 6 with a hole as large as a man's hand jammed through one side of it near one end. Cracks radiated from several corners of the hole. The part knocked out of the hole was entirely missing, a fact that complicated the welding. Besides the main break there was a crack six inches long farther down on the side. The vicinity of this crack bulged outward slightly. Picture No. 1 shows the location of the fractures. The fact that they were both near one end of the case simplified the welding a great deal.

Getting Ready To Weld.—One big advantage in the welding of aluminum crank cases over cases of other metal is that not nearly so much preparation is needed as is necessary on other kinds. The edges of the break are not beveled or chamfered, nor is the crack grooved out as would be essential on cast iron jobs. The oxide will form whether the fracture is grooved or not. So this tedious feature was dispensed with.

The vicinity of each fracture was cleaned of all grease and dirt. The edges were washed clean with gasoline and a portion of the cast-

ing scraped bright along the break for an inch back on all sides. This cleaning and scraping exposed the naked metal and prevented any foreign substance from interfering with the weld.

A medium size tip was fitted to the torch. Since aluminum melts so easily a large tip would have caused trouble in handling the metal due to the greater amount of oxide, or danger of it. A small tip would not furnish new metal fast enough to keep down the oxide; this sounds paradoxical—a large tip causes more oxide—a small one does too. The reason why it is true that the small tip does is because there are more edges to join, each drop of filler offers fertile field for oxidization. The larger quantities naturally furnish less exposed surface. An aluminum filler rod a fourth of an inch in diameter was selected as the proper size for this work.

Preheating.—As soon as the casting was ready it was placed upon the floor where it could be rolled over easily in order to keep the weld level. One end of it was covered with asbestos paper as shown in picture No. 2. A single gas burner was used to heat the portion of the crank case covered with asbes-

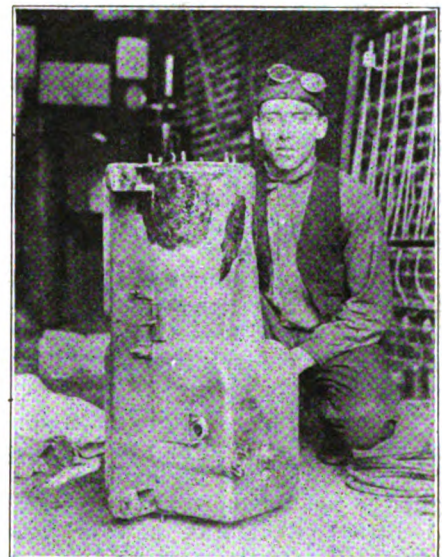

FIG. 3—THE JOB AS IT APPEARED WHEN COMPLETED

tos. This portion only was heated until it would fry drops of water near the break. There was some danger of getting the casting too hot in which event it might have sagged and fallen to pieces or become distorted. The job was heated only enough to start the expansion so there would be no danger when the sudden intense heat of

the welding flame was applied. When the patch is filled in other than the manner described below it is necessary to heat the casting to nearer the melting point. As in this case where the heat is confined or prevented from spreading it is necessary to get only the vicinity of the weld good and warm since a higher temperature would defeat the purpose of the localizing.

The Localizing Method.—Before placing the casting upon the floor it was arranged to localize the heat of the melting weld. This was in effect what foundrymen would term a "chill." Its purpose being to cool and set the metal almost as fast as it was melted in place. Thus bringing the filler metal almost instantly to the temperature of the surrounding casting. The chill was used only on the large opening; the long crack being welded by the puddling method.

To effect the localizing a piece of galvanized sheet iron was cut to fit and bent to conform to the inside curve of the crank case back of the open fracture. This piece of galvanized iron was wedged tightly in place on the inside of the case back of the hole with crooked iron rods of small diameter but very stiff. The rods were crooked to permit full play of expansion which might interfere if straight braces were used. As the casting expanded the bent rods straightened enough to hold the chill tightly in place. Sixteen gauge iron was used on account of its greater chilling quality. A lighter thinner iron heats quicker thus losing part of the chilling effect. The galvanizing causes the aluminum to peel loose readily after the weld is made. The filler metal sometimes adheres tenaciously if black iron is employed.

The Welding.—To revert again to our job: as soon as the job was hot the torch was lighted and regulated to a standard neutral flame. A little patent flux powder was sprinkled over the starting point of the weld. This part of the weld was melted together with about an inch of the filler rod. The filler was melted directly onto the galvanized iron in one corner of the break and joined to it by patting the puddling the casting and filler together under the flame. The hole was melted full a corner at a time. Each set of corners formed new angles to be filled until the entire hole was welded. After the first small corners were welded by puddling the

welding was accomplished in detail in the following manner. The filler rod was held flat on the chill along the edge of the previously welded corner; the flame was played along the filler to bring it to a melting stage the full length of it. As soon as the filler started to melt it was twisted over and over toward the already welded portion. This portion was brought to a melting stage at the same time with the filler. The two were thus melted and twisted, so to speak, together. Then the filler was again placed flat along the last strip of metal and melted into it with the same twisting motion of the rod. This twisting motion had the same effect in a way as had the puddling. It might in fact be termed puddling in another form. The oxidization was prevented or broken up and floated to the upper surface of the weld permitting the new metal to thoroughly fuse to the metal added before.

The flame was kept continually in motion during each step of the welding on the chill section, playing back and forth along the edge of the break and filler rod. Always directed across the weld in an endeavor to ward off the oxygen of the air. The welding was essentially very rapid in order to make it continuous. Each new strip was added to as soon as possible because the galvanized iron sets the new metal almost as soon as the torch moved to another strip. Then too it was desirable to prevent the heat of the flame from spreading to wide areas of the crank case destroying what was gained by the chill effect.

At last there remained a small vacant space near the center of the chill. This was welded by puddling; the welder melted this space full of new metal, then played the flame over it keeping it in a molten state while he patted and poked until it was thoroughly knitted with the edges of the hole. The pressure of the flame was used at times to blow the fluid aluminum into lower spots. This puddling was accomplished with the filler rod as a puddler; it could have been done with a special device for this purpose. A common form of which is a small iron rod flattened at one end.

The long crack was welded after the "chill" weld was complete. Before starting the crack weld the chill weld was covered with a pad of asbestos paper. Then the crack

was uncovered and welded from one end to the other by the puddling system, employing the filler rod as a puddler. First about an inch of the crack was melted then the melting filler which had been dipped in flux was drilled into it. The two sides of the crack were kneaded together with the rod. An inch at a time was puddled thus. The filler rod was dipped in the flux at frequent intervals. Very little filler was actually used in the crack, only what was melted from the filler rod in keeping it hot. A small surplus was added along the crack, but this was deemed a waste, and it is unless properly sloped and joined to the casting, which is a difficult trick on aluminum. It requires a clever manipulating of the flame and puddler. It is not so necessary to hot-finish aluminum welds because the metal cuts easily and can be smoothed just as well cold.

Cooling.—The last part of the welding process was the covering of the crack case to cause it to contract evenly. Although there should be little of this to contend with if the chilling has been successful. Asbestos was tucked around the welded end of the job in such a manner as would prevent any cold blasts of air from striking it. This covering was allowed to remain until the case was cold enough that the bare hand might be placed upon it with no danger of a burn. Then the galvanized chill was peeled from the inside of the case by inserting a thin chisel between it and the casting, curling the iron back a little at a time. If this work is carefully done there is no danger of breaking the weld.

The chill being removed the outside of the weld was filed smooth and given a heavy coat of shellac as shown in picture No. 3. The shellac was for the purpose of sealing any minute "pin" holes that might show up after the case was back in service. The use of the shellac is not a flimsy device for covering up defective welds. In reality it hardens in the pin holes when they soon fill up with sediment thus preventing any after leaks. Which is much better for all concerned than to attempt to doctor the weld after it is finished.

The man who thinks he knows it all hasn't even begun to learn. For the more a man knows the more he knows that he doesn't know.

"NEVER TOO OLD TO LEARN"

D. G. Baird

I had finished my business in Glasford, Peoria County, Illinois, and was strolling along the one street of the hamlet anathematizing a railroad service that would leave one stranded for a whole half day in such a place. "The day is not far distant," I thought, "when the automobile will force the railroad to give the public service or else get out of business. Take this little burg now, for instance. If these people knew that they were alive they would have regular passenger service to Pekin and Peoria; they would have truck routes to Springfield, Chicago and Detroit that would haul their pig, their dozen eggs, their five bushels of potatoes right to the good market and bring back the hardware, the dry goods, the groceries that they can't get here;—yes, and they would have tractors pulling their plows across these level farms dragging a dozen plows where their horses only pull one—"

I was about to forget my grievance with the railroad company and launch out into a lofty encomium of the gasoline engine, when a crowd on the narrow walk halted me and broke the chain of my lofty thought. And it was a crowd. In justice to Glasford I confess that I wouldn't have believed that there were so many people within a radius of twenty miles of the town.

A very wise man once wrote something unintelligible about the psychology of the crowd. I don't know what he meant by it, but I do know that a crowd always draws a crowd. Not even a two-story house on fire or a dago with a hand-organ and monkey can compete with a crowd in the subtle art of attracting the gentle and unsuspecting people.

Not being radically different from others in my general make up I paused to investigate the cause of the gathering. The chief object of attention immediately revealed itself in the comely form of a Ford tractor—or maybe it was the man with the machine who was causing this blockade of traffic on the main street of the city. It doesn't matter anyway for the two were inseparable. Up and down, around in front, back to the rear, underneath the hood went the man with the machine, explaining to this interested bystander the mysteries of ignition and transmi-

tion; to another the draw-bar pull; answering a perfect volley of questions to the seemingly perfect satisfaction of his many interrogators. But the most interesting part of the performance, to me at least, was the fact that the lively jockey of this gasoline steed was a man of at least three score years and ten.

Being of an investigative turn of mind myself I put on my best manner and inquired of an uncouth youth standing near: "Pardon me, young sir, can you tell me who the old gentleman with the coiled-spring resiliency in his step is?" "The one who seems to be the engineer of that cornfield locomotive," I added as his lower jaw dropped and a look of incomprehension slowly crept over his bovine features.

"Ole gen'lemen?" he asked in a perplexed tone.

"Sure, the one who is doing those acrobatic stunts there on the stump-puller."

"You mean Mister Ellis there what's demonstratin' ther tractor?"

"You guessed it the first time. What did you say his name is?"

"Wy that there's Mister Ellis. Mister Martin Ellis."

"I see. And who is Mister Martin Ellis, if you please?"

The youth looked at me with an expression of deepest contempt of such ignorance: "Yer mean t' say yer don't know who Martin Ellis is?... Wal, if yer don't know, he's the proprier of the Emporium over there an' the riches' man in three counties an' the agent fer Ford tractors in this here county an' he knows more about 'em than Ford hisself." And having delivered this lengthy oration my young friend turned back to watch the performance.

At the hotel I found Morely, the proprietor, sitting with his feet on the banisters and smoking a villainous two-for-five cigar in perfect bliss. Having no other convenient topic for conversation I casually mentioned the demonstration that I had witnessed up the street.

Morely took his feet down from the palings and spat upon the back of a frying-sized chicken that had ventured up on the veranda. "Ellis?" he said in his drowsy tone. "Oh yes, Ellis is the leading citizen of this prosperous metropolis and the chief object of interest to about nine-tenths of the population of Peoria County these days. He's a living example of the truth

that it's never too late to learn."

"Have a smoke," I encouraged, offering him a two-bitter as I sensed an antidote for the "taedium vitae of the next hour. "How's that?" I asked as he carefully stored my smoke in his breast pocket.

"Well, Ellis was running the Emporium when I was born, and before I reckon. He was a good business man and for a long time he got all the business of the surrounding country. That was before the railroad came through and before there was any other stores in the City. When his boy Jim got grown and got married he give Jim a interest in the store and ever since then it's been 'Ellis and Son.' That was before automobiles had ever been seen in this part of the County.

"Then the automobile come along and the old man got interested in the gasoline buggy and purty soon he bought the first one that was ever seen hereabouts. Then come the auto truck and he got one of them to do his haulin' on his farm out in the edge of town and tried to get everybody else in the country to get one too.

"You know some folks is just born conquerors, as Napoleon used to say meanin' by that that some of us is born to be mechanics and some to be farmers and some to ary-naughts and the like. Well, Ellis was sure born to be a automobile man. Yessir, he just naturally took to everything and anything that had a gasoline engine about its person. And so when the tractor come along the old man just couldn't sleep nights for thinkin' what the tractor would mean to the farmers of the County. He talked tractors to everybody that would listen. On Sundays he would drive out into the country and picture to himself tractors pullin' the gang-plows across the fertile acres and threshin' the wheat and pullin' the stalk-cutters and doin' almost everything except milk the cows.

"Then he began to talk about the tractor business prospec's for the Emporium. But Jim didn't much like the idea, 'specially since nobody in Glasford knew the habits and inclinashions of tractors. But the old man kep' thinkin' about the glorious prospec's of the tractor business in our thrivin' little city and the great and noble service he could do for the inhabitants of this county by goin' into the said business and one day he suggested to

Jim that he go up to Detroit and learn all about this partic'lar brand of gas-eatin' device so's they would be in a position to sell the machines. But Jim's nigh onto fifty himself and he had a feelin' that runnin' around over the country and goin' to school like a boy wasn't just exac'ly befitin' his honorabl' station in life. Anyhow he was too old to learn a new business, he said."

Here Morely looked sadly at the stub of his two-for and lazily cast it at a sparrow that had lit in the Virginia creeper at the end of the veranda. Absent-mindedly I handed him another of my Havanas and with a "thanks, don't care if I do," he resumed his story.

"Well, the old man wasn't to be outdone and so he approaches Jim's son on the subject. But he hadn't been married long and he didn't have no hankerin' to leave his young bride and his crop and run off to Detroit to study such a new-fangled business anyhow. Besides Jim's boy never was much of a scholar in school and dropped out before he got to high school and chances was, he said, he wouldn't be able to do the work in them big automotive schools in the city.

"Things went along as usual, but old man Ellis had tractoritis and he was determined to communicate the disease to the worthy people of Peoria County. He was sixty-nine years old, a man with great-grandchildren, but one day he packs his grip and starts for Detroit. He didn't say nothin' to nobody about his particular business, but in a few weeks back he comes—and a tractor comes with him—with a knowleg' of them machines that's astonishing' sir. And that's Martin Ellis, the only original and genuine proof of the great truth first announced by the famous Doctor Pluto, 'A man's never too old to learn!'"

"I see. When youth gets too old to learn great-grand-dad steps in and shows the way, eh?"

At that moment a big twenty-passenger sight-seeing car drove up to the steps of the hotel and the driver honked his horn with a familiar air.

"Say. What's the band-wagon doing strayin' so far from the bright lights and the historic associations," I exclaimed in utter bewilderment.

"That," explained the proprietor of Glasford's best, and only, hotel, "is Martin Ellis' thru passenger service to Pekin and Peoria, one

dollar and a quarter one way for the round trip—"

But I was racing for my grips.

THE RUSH FOR CARS

John Y. Dunlop

There is a very great demand for all kinds of motor cars in England at the present time and many agents have long waiting lists of patrons which it is questionable can be supplied—this season and the result of having to wait so long is making many invest in second hand cars.

The vast majority of motor dealers are, I believe, genuinely disturbed by the scramble going on by which they must see the ultimate outcome clearly and the man in the trade who is anxious to guard the good name of his business has been pretty careful in not encouraging the indiscretions of would-be motorists with more money than knowledge or sense.

There is a time coming when many buyers at the present scramble, instead of blaming themselves for having bought a box of trouble will be looking for some one else to blame and the far-seeing agent is taking care that he won't be the scapegoat.

Of course, it was quite possible before the war, on many occasions to get a perfectly serviceable car at a moderate rate if the business was gone about properly.

Today however, the risks are very much increased because the great demand has brought into the market all kinds of "duds" and has enabled their owners to procure quite outrageous prices for them. All this is bound to bring about a harvest of trouble both in the shape of outrageous repair bills and later to discover that there is no chance of reselling what they had bought in a reckless moment at anything like the price they had paid.

The man who has had the patience to wait for a new car will, in the long run, be able to congratulate himself on his wisdom because the prices being asked for many of these pre-war cars look perfectly insane when compared with £450 asked for an August-Sanderson or the £495 for an Austin.

Assuming as we are entitled to do, that these cars are reasonably like their advance description or the one or two sample models. One cannot just work out the same reasoning to the case of those who

have agreed to pay high premiums for a place on the waiting list.

In these cases it is plain that money is no serious consideration. There is a class of people who are making huge fortunes and can afford to indulge in practically any whim. The fact that they are not getting the best of value for their money gives them no concern and they are after all a small class and do nothing for the designing of cheap machines to which the trade depends so much.

The cheap car is often talked about as attaining cheapness by its manufacture in huge numbers but it must also be cheap to make in comparatively small numbers. The Ford car is constantly referred to as the standard example of mass production but the first Fords were, I understand, not manufactured on a huge scale.

I think about 8000 was the first year's output and some of our English makers are aiming at a number far beyond that and the British manufacturers are quite hopeful of turning out a car on similar lines when he sets himself to it in earnest. He has not done that hitherto because he did not need to but he will be doing it before long partly because he will have to do it.

The British knockabout car in the future will not be a Ford. It may or may not be much better but it will be different because the problem will be attacked from another angle and at a guess one may suggest that it will be much more like one of our newer light cars than it will be like a Ford.

ANDEAN HORSESHOEING

In Harry A. Franck's book, *Vagabonding Down the Andes*, appears the following entertaining and highly descriptive account of a typical Andean horseshoer at work.

"Around the corner the cobbled street was blocked by a horseshoeing contest. This is always considered a very serious business in the Andes, though the average horse is so small that a real blacksmith could toss him around at will. A bare-foot half-Indian 'herrero' (blacksmith) had emerged from his mud dungeon shop, containing a forge from Vulcan's time, but by no means the space necessary to admit the animal, and stood watching the preparations for his feat with the critical and anxious eye of an aviator about to attack the world's record. One of the three attendant Indians threw his poncho over the head of the chusco (horse) and bound its eyes. Then a rope was drawn tightly around its neck, with a choking slip-noose about its nose, an Indian clinging desperately to the end of it as long as the contest lasted. Next a llama-

hair lasso was bound to the animal's nigh front fetlock and the foot hoisted by another attendant on the off side who used the back of the trussed brute as a pulley. A third Indian held the foot by hand. When all was ready, the valorous blacksmith sneaked up and pared the hoof a bit with an instrument much like a small, sharp, shovel with a long handle—pared it very imperfectly, as is the way of Andean blacksmiths, leaving so much of the toe that the animal was in constant danger of having an ankle broken on some rough and tumble trail. Then he hunted up a cold horseshoe, without calk, just as it came from the hardware store that had imported it from the United States—for the Andean blacksmith never heats a shoe, much less alters it—and laid it gingerly on the hoof. Evidently, to the inexact eye of the herrero, it fitted. He clawed around among the cobbles and refuse of the street, where his tools lay strewn and scattered, until he found several hand-forged horseshoe nails of the style in vogue in our own land before the Civil War, and standing afar off, like a man willing to risk his life to do his duty, yet not to risk it beyond reason, started one of the nails with a Stone-age hammer. Suddenly the foot twitched. The blacksmith sprang backward a long yard, with blanched countenance, the foot-holder fled, and the two remaining Indians cried out in startled Quichua, while clinging to the far ends of their rope. Bit by bit the herrero crept up again and took to driving the nails at long range, as if he were mashing the head of a venomous snake, poised on his toes, ready to spring away at the slightest sign of life in the blindfolded animal. Gradually the eight nails were driven, not without several repetitions of the blanching fright, and the operation repeated with the other hoofs. Finally the blacksmith maneuvered to positions in which he could twist off and crudely clinch the protruding nail points, rubbed with a rasp once or twice over them, and the perilous job was done. The fiery steed was relieved of the blinding poncho, the Indians went to restore their nerves with a copita of pisco, and the blacksmith, collecting fifteen cents a shoe from the owner of the animal, shut up shop forthwith, as if he had risked his life enough for one day."

MANUFACTURING RAZORS

E. M. Peterson

The very essential thing at the outset is to get good steel or even special steel for the particular purpose of making razor blades. Suppose that one man says he makes razors from 1.55 carbon steel or something like that, and another advocates the use of .95 to 1.15 carbon steel. The first is too hard and the last is too soft for fine edged tools. A good refined tool steel from 1.20 to 1.35 carbon is most suitable for the purpose and the size I like best is $\frac{1}{2} \times 2\frac{1}{4}$ inch but if regular razor steel, rolled to shape can be obtained it is preferable as much work will be saved in grinding and other operations.

For a heavy razor the bar should be about $\frac{3}{4}$ or $\frac{5}{8}$ inch wide and if,

as has been mentioned, it is in the rough form of the razor, all the maker will have to do will be to hammer out the tang and cut it off to the proper length.

To get a good edge or to get "good life" in a razor blade requires a good deal of hammering which is hard work and which anyone trying his hand at razors will learn. If any number of blades are to be made it will be found of considerable advantage to turn them out under the power hammer.

After the razor has been forged out to the desired shape it should be evenly annealed and roughed off on an emery grinder and the hole drilled in the tang. For best and most uniform results in hardening a gas furnace is preferred which is heated up to about 1475 or 1485 degrees. The temper can be drawn to between 425 or 450 degrees if care is used in grinding not to bear too hard when the blade is concaved. If the grinder bears too hard the blade must be tempered harder.

Alloy steel is too hard and can hardly be considered as suitable for fine cutlery. Some of the various makes of steel which can be made into razor blades are; Sterling tool steel; xxx Bethlehem; No. 7 Colonial Steel; Wardlaw steel; Hawk-ridge steel and Toledo steel.

ANCIENT STYLES APPLIED TO 20TH CENTURY

There are many styles and types of automobiles in use today, but probably the five best known and most popular in the United States are the Coupe, the Sedan, the Limousine, the Touring Car and the Roadster. The first three names are French in their origin and the last two are English.

The word "Coupe" was applied originally to a four-wheeled closed carriage for two persons inside, with an outside seat for the driver. It is derived from the French word meaning "to cut" and is so-called because it gives the appearance of a larger carriage cut in half. The word was later taken over and applied to the present enclosed car with one seat in the rear, a driver's seat, and an auxiliary seat.

The word "Sedan" is probably one of the oldest terms applied to a vehicle for transportation. It was used for the first time in France and takes its origin from the French city of that name. This name takes on a peculiar significance now when it is remembered that the sensational advance of Pershing's

fighters reached Sedan when the armistice was signed. The first Sedans were portable enclosed chairs carried on poles by two men. They were extremely popular in England and are still used in China, Austria and India. The modern Sedan has an enclosed body and accommodates seven passengers. Because of the single enclosed compartment it is popularly known as the all season, all purpose family car.

"Limousine" was originally the name of a cloak worn in France, and probably originated from Limousin, the name of an old province in central France. Today it is applied to the chauffeur-driven car with an enclosed compartment. The driver's seat is outside, but covered by a roof.

"Roadster" was first applied to vessels that worked their way by means of the tides. Later it was used for bicycles. The modern roadster has an open body and was designed primarily for two persons, but of recent years the four door roadster, accommodating four passengers, has met with popular favor.

The touring car, which is the most familiar type of car, takes its name from the fact that it is used by motorists on lengthy tours. It is an open car also, with a tonneau and four doors, seating seven passengers.

EXPECT SOMETHING NOW

For some time past there have been all sorts of rumors current in the automobile world that the Ford Motor Co., was about to be absorbed by the General Motors Co., or other interests and while all such reports were insistently denied by the Ford interests, speculation refused to die. It now transpires that the stock in the hands of minority stockholders has been bought up by Henry Ford himself, with the exception of a small block owned by James Couzens, a former vice president of the company and now mayor of Detroit. The minority stock includes the stock held by John F. and Horace E. Dodge of the Dodge Brothers automobile company, who it will be remembered successfully fought against the application of some \$19,000,000 to certain Ford policies of extension and which was later distributed as dividends.

Heretofore, Ford has owned 58½ per cent of the stock. He now owns 89%.

VALUE OF PROPER COST ACCOUNTING TO BLACKSMITH AND REPAIR MAN

William J. Bryans

THE man in any line of business today cannot afford to operate along hap-hazard lines. If he hopes to reach the Port of Success he must keep headed in the right direction all the time. The compass that will allow the business man to avoid the shoals of failure is system. He must know at all times in what direction he is progressing and whether his progress is sufficient. Proper cost accounting will give him the necessary information.

It makes no difference how small a place of business a man conducts, a business system is just as necessary as with the larger establishments. There are scores of blacksmiths and repair men who go on from year to year with no knowledge of their business progress except that they know at the end of the year how much money they have in the bank and that is frequently conspicuous by its absence.

Every man should conduct his business on a business basis and entirely separate from his own personal affairs. So many men mix business and personal funds and accordingly are never in a position to tell exactly how much money they are making. All money and transactions should be kept separate along with an account of the money which the dealer takes out of business funds for personal use. The best policy is for the dealer to arrange a regular drawing allowance for himself.

To conduct his affairs on a real business basis even the small dealer should keep an account of all his expenses and charge them up against gross profits. The balance gives him his net profits, or the amount of money the business itself has earned.

In figuring his expenses he should make certain that all the items are included. A good many dealers add up the amount of their rent and wages, along with another odd item or so, and seem to think that they have the total of expenses. This is certainly a mistake. Some of the items that should be charged up in the expense account are:

- 1—Rent.
- 2—Fixed expenses—taxes, light, fuel, insurance and telephone.

3—Wages, including salary to himself.

4—Advertising—newspaper, cards, posters, letters and circulars.

5—Miscellaneous—printing, stationery, postage, cleaning.

6—Losses by bad debts, breakage, shrinkage, leakage, destruction, etc.

7—Depreciation—equipment, stock, etc.

8—Charge for what capital

THE STRENGTH OF
GLUE VIVIDLY ILLUSTRATED

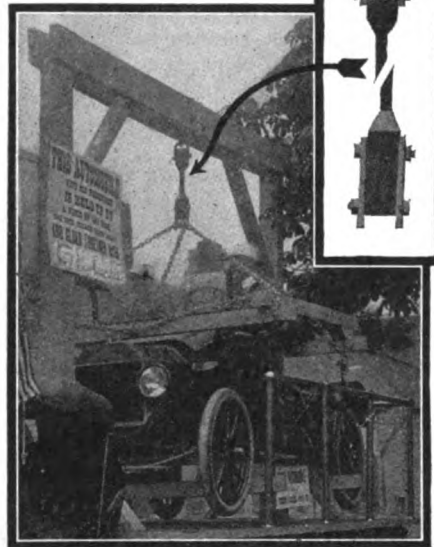

A glue factory is the standard by which all other smells are judged—for strength, though few people have any idea of the actual strength of glue itself. It remained for a prominent eastern manufacturer to demonstrate in a convincing manner that the glue they make will hold anything.

A one inch oak bar was sawed in two, as shown in the insert, and glued together. In the larger picture the entire weight of a Ford roadster and its heavy wooden cradle (2600 lbs. is supported by the glued piece. This demonstration was placed on a motor truck and the exhibit used in a parade after which in the presence of the mayor and other competent witnesses the bar was broken to show that the glue was not supplemented by bolts or other devices. A force of 6030 pounds was required to break the bar.

would earn if invested in some good security.

A man should always include a reasonable salary for himself in expenses. If he hired some one else to run the business he would have to pay him a salary. Similarly, if he has a son helping him, even at spare time, a sufficient sum should be charged up in expenses for the service rendered.

In the same way, if a man owns his own building he should make a

charge against the business for rent just as if he were renting it from some one else. If he had the money otherwise invested he would be drawing from 5 to 6 percent on it.

The balance, after the total of all these items of expense is deducted, gives the net profit—which is the profit that the business earns and the return which the business man receives for the changes taken in engaging in the business.

Cost accounting should also be applied to individual operations in connection with both shoeing and repair work. For each class of work the cost of material, the value of time spent in the operation and a percentage for overhead expenses should be added together and from the total a price set for the work that will give a sufficient profit. The cost of material includes the original cost any expense incurred in setting the goods down in the shop ready for sale. Many dealers add to this a small profit just as the druggist puts a profit on the drugs entering into a prescription when making up the cost. The dealer knows just about the length of time it takes him to do various lines of work and can easily figure out the amount that should be charged up for this. From the amount of business done a percentage on the dollar can be figured out for overhead expenses. With these three items the dealer is in a position to arrange a price for each line of work.

In automobile repair work it is the usual procedure to charge the material used on each job as a set retail price which includes overhead expenses and a net profit. To this is added the time taken by the repair man to do the work at a certain set figure per hour which covers the wage paid the man with an allowance for general expenses in connection with this branch of the business.

In order to arrive at the proper retail price for goods expenses must be figured out on a percentage basis. To do this the dealer must know his cost of doing business over a certain period and his sales for the same time. If your cost of doing business for a year, is, say \$1800 and your sales are \$10,000, then your percentage of cost of doing business is 18 percent. Here is how it is figured out:
On \$10,000 the cost of doing business is \$1800.

On \$1.00 the cost of doing business is 100x1800

equalling 18 cents 10000

Therefore cost of doing business is 18 percent.

With a business of any great size the sales department and the repair department should be kept separate. The actual expenses in connection with sales with its proper proportion of rent, employees' time, etc. should be charged up to that department. In the same way the repair department should bear its proportion of rent, depreciation on tools, leakage, etc. and this overhead should be taken into account along with wages in figuring out the amount per hour to charge on all work done.

The only way to make sure on success is to make certain that you are actually making a profit on each department and on each transaction. Proper cost accounting will show you the way.

FORDSON REDUCED \$135

Henry Ford & Son is wiring all distributors of a reduction of \$135 in the price of the Fordson tractor. The new price, effective at once, is \$750. The old price was \$885. The price to the distributor is \$600 and he turns it over to the dealer at \$635.

The Fordson tractor plant is now getting back into heavy production. Approximately 100 machines are being completed daily.

RESERVE POWER

In using a team every man knows that it can, for a moment, pull twice or three or even four times the load which it would be capable of for a full day, and it is just as necessary to have reserve power in a tractor. When a plow goes into the ground, or when it strikes a root or big stone, there is an extra load strain. Emergencies may double the load. So if a tractor is capable of an actual drawbar pull of 12 h. p., the regular load should not exceed 6 h. p.—for instance, three 12-inch plows in average level soil.—Rural New Yorker.

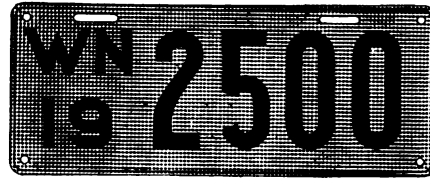

WASHINGTON—Black and yellow. Weighing 1500 pounds or less, \$10; over 1500 pounds, \$20 and 60 cents per 100 pounds in excess of 1500 pounds.



IDAHO—Tan on dark green. Registration according to weight—2,000 pounds or less \$15; 2,000 to 3,000 pounds \$20; 3,000 to 4,000 pounds \$30; 4,000 pounds or over \$40. Registration fee on motor vehicles except manufacturers and dealers, exempts same from personal property tax.

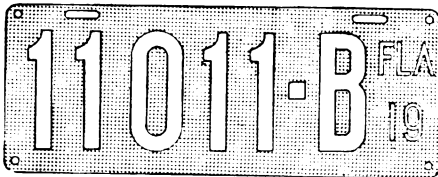

FLORIDA—Black on orange. Registration according to horsepower, from \$3 to \$15.



IOWA—White on chocolate brown. Fee according to horsepower, from \$8 to \$34.56.



GEORGIA—Black on white. Not over 25 h. p., \$3; 25-40 h. p., \$4; 40 h. p., or more, \$5.



WEST VIRGINIA—Black on white. Fee, \$10 for each 2,000 pounds or less and 25 cents for each additional 100 pounds or fraction.



MINNESOTA—White on black. Registration for commercial and passenger cars is the same being \$5 for a three year period.

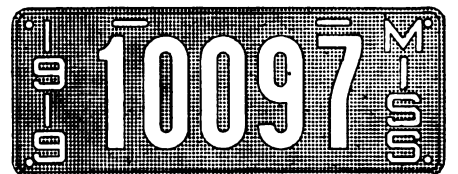

MISSISSIPPI—White on dark green. Fee, 24 cents per h. p. Minimum fee, \$5.



MONTANA—Black on pale green. Fee, \$5 for not more than 23 h. p.; \$10 for cars not exceeding 50 h. p. More than 50 h. p. \$15.



TENNESSEE—White on dark blue.

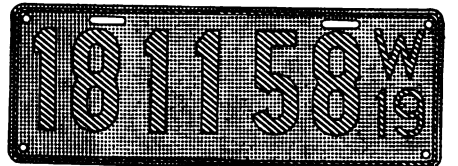

WISCONSIN—Bright yellow on dark green. License fee, \$10.

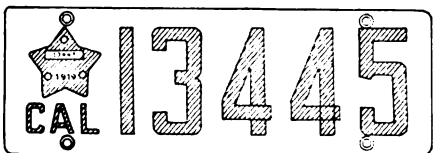

CALIFORNIA—Blue on white with Red Star containing year and makers number of car. Registration 40 cents per h. p.



MASSACHUSETTS—White on black. Registration from \$5 to \$25 according to h. p.

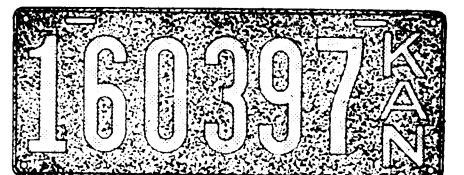

KANSAS—Dark blue on sky blue. Fee, \$5.

DRILL PRESS CLAMPS

These four types of clamps or screw straps were designed by the writer for making it easy to secure readily any sort of work to the drill press table for drilling. They

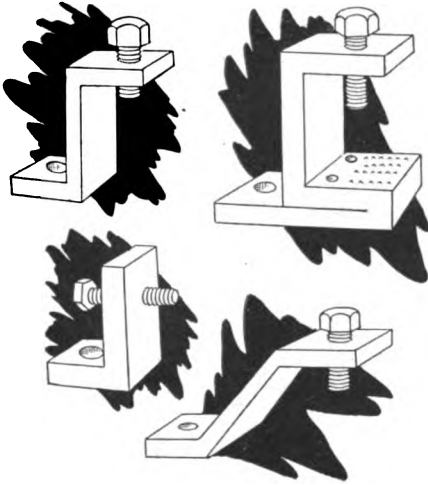

DRILL PRES CLAMPS

provide an excellent substitute for a drilling vise and are quickly attached to the angle plate. All are made from 3/4x2 inch flat stock and do not call for skill in the making. The screws are machine steel with case hardened tips for wear.

MAKESHIFT FORGE

Having been out in the foot hills for part of a season on some prospecting I ran across a rather unique idea in makeshift forges. The prospector's tools were redressed and considerable other work done with it. The sketch shows how a galvanized iron wash tub, a bit of pipe, and a hand blower

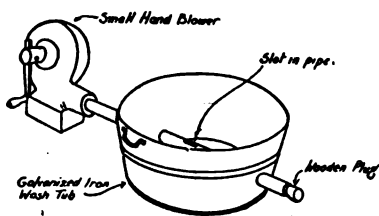

MAKESHIFT FORGE

were rigged up to serve as the forge. The pipe was put straight through the tub at about 2 1/2 inches from the bottom. A slot was cut in the pipe, as indicated and earth then put into the tub level with the pipe, then the fire made on top. A wooden plug was used in the end of the pipe and provided means for cleaning out. When on the move the tub serves as a handy thing to pack stuff into.

WISE BENDING JAWS

I stepped into a local garage one afternoon to get some stuff I was short of, and I noticed a pair of

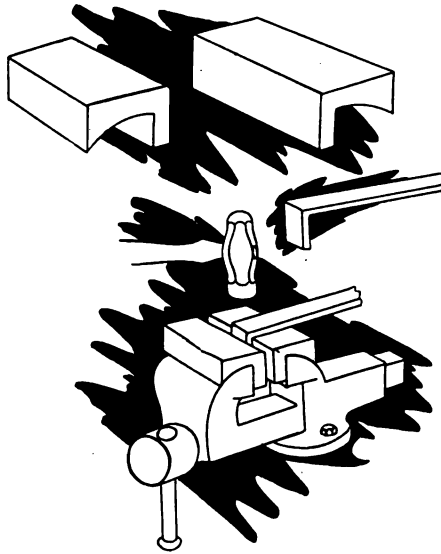

WISE BENDING JAWS

jaws that one of the mechanics was bending some short corner braces over from cold stock.

I borrowed the idea for my own use and have permission to pass it on to all the boys, so here are the sketches showing how to make and use them. The bands made with these jaws are clean and square.

SIMPLE PACKING SCREW

For a few minutes outlay of time one can make a set of handy packing screws from common wood screws and pieces of steel wire or round rod. The screw head is cut off and then the end of the screw

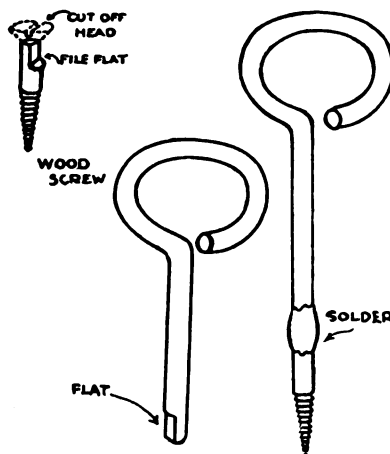

PACKING SCREW

is filed to one-half thickness, as indicated in Fig. 1. A handle of any desired length is made of the nearest size wire, as shown in Fig. 2. This also has the lower end filed

flat. When the two are placed together and soldered, as indicated in Fig. this joint can be pinned or riveted together. Such little packing screws as these are mighty useful to pull the packing from the small stuffing boxes of circulating pumps, oil pumps, etc.

STOCK CENTERING RIG

Where one has any considerable amount of short lengths of round stock to center for turning in the lathe (lengths up to two feet) it will well repay him the time and material spent to make a rig such



STOCK CENTERING RIG

as I have sketched herewith.

The two cones A and B automatically place the stock in the center line of the center punch C. The sliding arm D has a key that slides in the keyway of the vertical post E. The base is made of cast iron. For time saving in a bush shop this rig is hard to beat.

MAGNETOS STAND ABUSE WELL

It is astonishing how much abuse the average magneto will stand. Instances are common where magnetos have been left out in the weather through the winter, have been caught in floods, sunk in boats, and yet have dried out without any overhauling at all and started the engine without fail. Farmers users in the northwest report that 30 degrees below zero made no difference in the operation of the magneto.

Queries-Answers-Notes



THIS department is the meeting place where you are free to ask for information, answer questions, discuss shop matters and business conditions and any other notes you feel would be of interest to a fellow mechanic. Make use of this Department as often as desired.

Resetting Spring Leaves—Anent the discussion that has been created on the resetting of automobile spring leaves by hammering, both hot and cold, as well as running the leaves through a tire bending machine, the question was taken up with Mr. T. B. Jenkins, president of the Jenkins Vulcan Spring Co., who furnishes us with the following authoritative information on the subject:

"It is absolutely impractical and inadvisable to attempt to reset leaf springs of any kind by peining them, nor would it be possible to obtain any kind of satisfactory fit by running them through a machine of the tire bender type. The shock of hammering them throughout the entire length of the springs would be very injurious to the metal and the tire bender method would be absolutely unreliable as to one leaf fitting satisfactorily against another.

"There is but one satisfactory method of resetting a spring so far as we have any knowledge, and that is to heat the steel to about 1900 degrees Fahrenheit, reforming carefully to a predetermined form, and immediately dipping the job in a bath of tempering oil. It is usual to sprinkle a little water on the hot plate before dipping it into the oil in order to make the plate hold its shape as it goes into the oil bath. The plate is then very brittle and must be drawn carefully. The matter of drawing depends a great deal on the degree of heat before quenching, but at 1900 degrees quenched in a moderately cool bath it is usual to draw until there is just the slightest suspicion of a dull red glow or about 700 degrees.

"In most cases there is a little fitting

necessary after the plate is drawn and allowed to cool slowly. This is done by a hammering process on a regular spring fitter's block or anvil but the amount of such hammering compared with what is necessary to completely change the set of the spring is negligible and not particularly harmful to the spring. It is merely necessary so that a snug fit between all plates is obtained."

In this connection it might be of in-

INDEX NUMBER

Volume 18 of the American Blacksmith, Auto & Tractor Shop will be complete with the September number. The index to the contents of all preceding numbers is contained in this number each year. This is a valuable number as it makes the various articles and helps readily available and if you fail to receive your September number (or any other one for that matter) another will be sent promptly on request.

terest to those of our readers interested in springs to know that they can obtain from the company mentioned all widths and gauges of spring steel of the following analysis: carbon .90 to 1.05; manganese .40 to .60; phosphorous .05 maximum; sulphur .05 maximum.

Trade Journal Changes Its Name—Our contemporary the "Crow Bar," has changed its name to the "Automotive Mechanic."

Soldering Aluminum—I am very glad I became a subscriber as I have found the

book contains good sound and valuable information and in all respects worth reading. I am now sending the addresses of two brother blacksmiths who wish to become subscribers and am enclosing a price list of our branch which was adopted the first of the year.

We are just now making a little headway here in England and getting paid back a little for our labor in years gone by. The trade is looking up a bit now and the prospects look good.

Can you give me a receipt for soldering aluminum? Some say that aluminum cannot be soldered and others say that it can be done and I shall be glad to have your opinion.

Charles Fisher, R. S. S., England.

Aluminum can be soldered more or less successfully but the most approved method of repairing articles of aluminum is by the oxyacetylene process, an excellent description of which is included in the present number. There are a number of solders on the market which are made expressly for soldering aluminum and doubtless your jobber or heavy hardware dealer can obtain this for you. Two formulas for aluminum solder follow: For soldering with the blowpipe use a solder composed of silver 10 parts, copper 10, aluminum 20, tin 60 and zinc 30. For soldering with the common soldering copper use tin 95 parts, and bismuth 5; or tin 91 parts and bismuth 3 parts. The flux to be used with this compound is either paraffine, stearin or vaseline. The articles in all cases should be well cleaned and scraped bright before soldering and heated just enough to make the solder adhere.

The horse Losing Out—Statistics recently compiled by the New York Health Department show that the horse is being replaced by trucks. Early in March, 1910, according to the report, there were 7,920 stables in New York city while at the same time two years ago there were 10,548. The report also shows that the number of horses declined from 108,036 to 75,740 during the two year period, the falling off being greatest in the Boroughs of Queens, Brooklyn and Manhattan. Of course there will always be a certain field where horses will be indispensable but their use is rapidly becoming more limited.

British Prices—We present herewith the minimum prices of the Reading (England) branch of the National Master Farrier's

FROM TANK

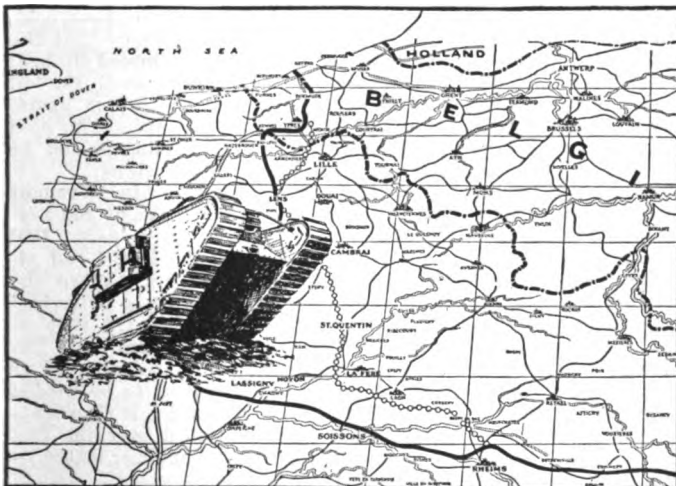

TO TRACTOR

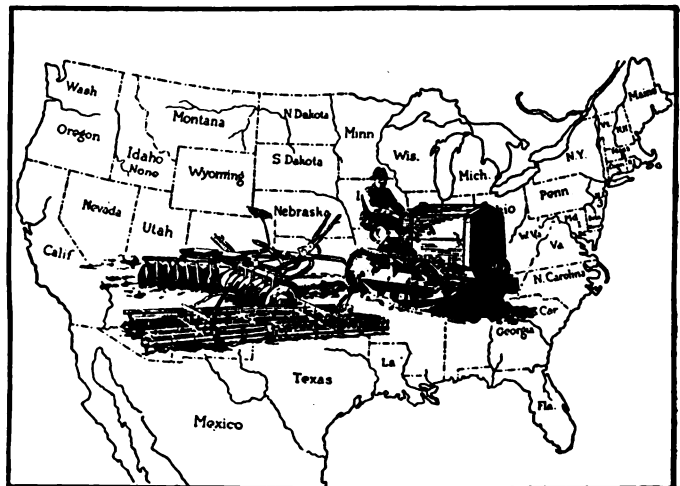

Association. The list as presented is published in a neat booklet that can be stored away in the vest pocket.

Shoeing—Heavy cart Horses, per set set 10/-; Medium ditto and cart farm horses over 7 ins., 9/-; Van horses and cart farm horses under 7 ins., 8/-; Hunters and carriage horses, 8/-; Tradesman's light and cab horses, 7/-; Cobs, 6/-; Ponies, 5/- Private Ponies, 6/-.

Extras—Shoes screwed or punched 2d. per hole. Removing or roughing 6d. over half price of shoeing. Roughing new shoes, 1/- per set. Frost nailing 1/6 to 3/-, according to size. Old shoes 1/- to 1/6 per shoe. Leathers per pair 2/- to 4/-, according to size. Pads from 5/- to 10/6 per pair, according to size and pattern. No horses shod with Frost Screws, cogs, pads, leathers, etc., unless provided by the Farrier. Colts, unruly horses and horses requiring special attention, charged for accordingly.

General Smith's work—Light Tyres up to 2½ in. 6d. per lb.; Heavy Tyres up to 4½-in. 5d.; Beveling Tyre ½d. per lb. extra.

Cutting and Shutting—Up to 1½-in., 8/- per pair; Up to 2-in., 10/-; Up to 2½-in., 12/6; Up to 3-in., 15/-; Up to 4-in., 20/-; Up to 4½-in., 22/6; Tyreing Barrow Wheel, 2 by ¼-in., 5/-; Lining Set of Harrows, 60 tines, 30/-; Sharpening Set of Harrows, 60 tines, 15/-; New single screwed Harrow Tines, 1/6 each; Lining Drag Harrow Tines, 9d.; Sharpening Drag Harrow Tines 6d.; Lining and Steeling Duck Foot Harrow Tines, 2/-; Sharpening Duck Foot Tarrow Tines 1/-; Lining Coulters, 2/6; New Blade to Coulter, 3/6; Sharpening Coulters, 1/- and 1/3; Coulter Cops, 2/6 each; Square Cops, 3/6 each; New Hames shoulder hooks, plates and staples 7/6 per pair; Dog Links Rings and Ling for Hame 1/3; Tug Hooks 1/6; Trace Hooks 1/3; Single Links in Traces, ¼-in. 3d.; 5/16-in. 4d.; Shut Links 3d. each; Clip Links for Whippetree, large 1/9, small 1/6 each; Hook and Half-Ring for Whippetree 2/3; Screwed Eye Pins with 3 Links for Harrow Pole 2/-; New Axle for Ploug Wheels 2/6 & 3/-; Drail Staples with Nuts and 2 hooks for Cart Shafts 3/6; Rigsty Chains and Traces, 25 per cent added to cost price. Lining and Steeling Pick 2/6; Sharpening Pick 6d.; Hanging Seythe and 3 Wedges 1/6; Mending Section back of Mowing Machine 3/-; Gate Ironwork heavy 9d. per lb., light 1/ per lb.; Builder's Ironwork heavy 9d. per lb., light 1/- per lb. Lining and Steeling Fold Bar 5/-.

Price List of Shoeing.—Proposed Flat Rate for Oxon, Berks and Hants District, to come into force on January 1st, 1919. Feet measuring under 4-ins, 5/- per set; 4½-ins. 5/6; 5-ins. 6/-; 5½-ins. 6/6; 6-ins. 7/-; 6½-ins. 8/-; 7-ins. 9/-; 7½-ins. 10/-; Carriage Horses, Hacks and Hunters 8/- per set; Private Ponies 6/ per set.

No Secret—Every once in awhile we're persuaded to admit that we publish the best paper in 48 states which is only another way of saying the whole world and even our readers feel the same way about it.

George Braxton dropped in on his fellow shop owner down in Halifax county, North Carolina, a few days ago and told him about the Auto & Tractor Shop. In telling us about it George says; "All he said was what's it worth? I told him that it cost a dollar a year but that a single issue was worth that much and that I have a lot of them I wouldn't take a dollar for. He just reached into his pocket and

gives me a dollar and says to have it sent to him."

When folks "take on" to our publication "thataway" and then tell us about it, say—"ain't it a grand an' glorious feeling?"

You'll Need This Later—I have heard many complaints from car drivers of frozen radiators. There are a number of anti freeze compounds on the markets but I am giving a suggestion that may be known to many and unfamiliar to others.

KNOW HIM?

Principally because that wasn't his name, we'll call him Smith. Mr. Smith bought an automobile. He paid \$2150 for it. He allowed no one to drive it but himself. He kept it in a new garage—a weatherproof structure with a cement floor. Every 500 miles he changed the oil in the crank case. For the first 1000 miles he ran the car no faster than twenty-five miles per hour.

Then he bought a tractor. It cost \$2900. He hired a tramp mechanic at \$3.50 per day to run it. When not in use, he left it in the old corral back of the barn. As long as nothing went wrong no one thought of changing the oil. And the second day he had it he took the heaviest plow on the farm down to an old alfalfa field, put the disc down as far as they would go, and said to the driver "Now step on her! Let's see what she's good for!"

Smith is rather a common name.

In cold weather the fan belt can be removed or the fan adjusted so that the belt will slip and not drive the fan at full speed. A piece of paper or cardboard may be used to cover all or part of the front of the radiator as necessary. I do not mean that these suggestions will prevent freezing when the car is not in operation but they certainly will add to the operating efficiency of the car in cold weather.

B. L. Brown, Canada.

Hardening Compound for Steel—Can you give me the composition of a simple and inexpensive hardening compound for hardening steel?

J. C. Beckwith, New York.

A compound that is said to give fine results for this purpose is made as follows: pulverize three parts by weight of prussiate of potash, 1 part of borax, 1 part of saltpetre and ½ part of sugar of lead, and intimately mix the whole. After heating the steel to be hardened to a red heat, take it from the fire and sprinkle the powder over it. The steel is then replaced in the fire, and after having been brought to the required degree of heat, cooled in cold rain water.

Tempering Mill Picks—Will you kindly furnish me with the best method of tempering mill picks for dressing French burr stones?

G. B. Crane, Georgia.

We don't know what the "best" method of dressing mill picks is, everyone has his own ideas on the subject and particularly for the purpose mentioned but the following method is reprinted from the December, 1917 number is highly recommended by a smith in the Ohio coal mining region.

The compound to be used is composed of the following easily obtained ingredients: nitrate of potash 1 ounce, bicar-

bonate of potash 1 ounce, sulphate of zinc, one ounce, carbonate of soda ¼ ounce, carbonate of iron 1 dram or 1/8 ounce.

Mix the ingredients thoroughly. Dress the pick carefully, not heating too high. Heat to a dark cherry red and put on each side of the pick as far up as you wish to temper, say an inch and a half. Put back into the fire (always on top of fire). Heat to a dark cherry red and cool off quickly by shaking pick in the water. Of course the hotter you make the pick the harder it will be. If the pick looks white, like silver, it is very likely to stand; if it looks somewhat cloudy after being tempered. If this recipe is properly filled, when put on the pick it will flow like water. Put first on one side and then turn over and put on the other.

Another and simpler method of tempering picks is to heat the pick in a charcoal fire until red hot and plunging into cold rain water and allowed to remain until nearly cold. Some blacksmiths use salt-water but no salts should exist in the water and it should be cold. If it is warm add a little ice and the tempering will be improved. Pure soft water used for hardening makes a tougher pick and one less likely to crack at the edges than where salt water is used. The last hammering of a pick should always be given on the flat sides, across close to the edges and then up each side about an inch. By doing so the corners will be less liable to crack.

Making Knives From Files—First draw the temper by heating the file to a cherry red, then place it in ashes, and five inches under the forge and allow to cool. Now grind out the file marks and next comes the drawing. Make the heat no higher than a bright cherry heat, and use a good smooth faced hammer. The file is then drawn a little thicker than the back of the blade is to be and the blade is then bent, the edge being on the inside. The blade is then drawn to an edge, the drawing on the inner edge having the effect of straightening it. When it has been drawn to a nice color and straightened, three holes are drilled in it with which to fasten the handle, and it is shaped with a file. It is necessary to avoid getting the edge too thin at this stage or else there will be trouble in tempering. In tempering use soft and somewhat warm water. Seize the handle end with a pair of tongs, hold the blade with the back down, over a clear, well-charred fire, and heat evenly to the first hole until the blade is red, and then plunge it endwise into the water. This should leave the blade so that when tried with a file, the file will take hold, just a little. If this test shows that the blade is too hard, dip it in linseed oil, hold it over a slow, clear fire until the oil ignites, then dip into the water again. This will toughen it and cause it to hold its edge better. The grinding should be done on a good, even faced stone.

Welding Wrought Iron to Wrought Iron—Borax one part by weight Sal ammoniac ½ part and water ½ part. Boil with constant stirring until stiff and allow to harden over the fire. When the compound has hardened it is pulverized and intimately mixed with 1/3 part of wrought iron filings free from rust. The pieces to be welded are first dovetailed or tied together, and the place to be welded is made red hot; the powder is then scattered upon it and liquified over the fire. A few light taps of the hammer suffice to join the pieces together.

AMERICAN BLACKSMITH AUTO & TRACTOR SHOP

VOLUME 18

SEPTEMBER, 1919

NUMBER 12

BUFFALO, N. Y., U. S. A

Established 1901. Published Monthly at the Sidway Building, Buffalo, N. Y., by the

AMERICAN BLACKSMITH COMPANY

Incorporated under New York State Laws.

WILLIAM F. WENDT, *President.*

WALTER O. BERNHARDT, *Editor.*

SUBSCRIPTION PRICE:

For \$1.00 per year, payable in advance, The American Blacksmith, Auto & Tractor Shop will be sent, postage prepaid to any postoffice in the United States. To Canada, \$1.25; to other countries, 6 shillings. Reduced rates to clubs of five or more on application.

Remittances may be made by money order, express order or checks payable to the American Blacksmith Company. We will also accept uncancelled postage stamps or currency, but for safety these should be sent by registered mail.

Subscribers should notify us at once of non-receipt of paper or change of address. In latter case, give both old and new address.

Correspondence on all smithing subjects solicited. Always give name and address, which will be omitted in publishing, if desired. Address all communications to the

"AMERICAN BLACKSMITH COMPANY"
BUFFALO N. Y.

Copyright W. F. Wendt Publishing Company, 1919 "

Cable Address: "Blacksmith, Buffalo"

AND WHY NOT?

Why is it that practically all the national tractor demonstrations that have been held to date have been held in states west of the Mississippi river? It occurs to the Editor that it would be a good idea for tractor manufacturers to get together and stage a few tractor field days somewhere in states EAST of the Mississippi. It is hardly reasonable to believe that all of the tractor interest is centered in that part of the country nor it is not any more reasonable to believe that farmers and others interested in tractors and their performance are going to travel all over the country to see such demonstrations, interested though they may be.

The Editor makes the suggestion, for what it is worth, to the tractor manufacturers and others directly interested in these national tractor demonstrations that they adopt some plan whereby the same would be held in a different state each year. Certainly demonstration fields can be obtained for the purpose and possibly it would be reassuring to some prospective tractor purchasers if the manufacturers could be induced to demonstrate the performance of their product in the hilly regions of Pennsylvania, for instance. Such demonstrations and their attendant records would then mean something.

If a national tractor demonstration is worth anything at all why not give residents in other parts of the country an opportunity to attend and see demonstrations made in territory that would show what could be expected of a tractor in their own fields.

If tractor demonstrations, such as are now held, must be conducted in territory where there is no perceptible grade visible to the naked eye what can be the object of such demonstrations and also why is it that such a fanfare is made over a record gasoline consumption of some other fool

record that can easily be duplicated by almost any machine under the same conditions.

FRANKLIN TOOK THIS RISK

Scranton, Penn., July 27.—While emulating Benjamin Franklin late yesterday, Andrew Loyak, of this city, was killed when a bolt of lightning followed the wet kite string from the skies.

Loyak was struck in the back of the head. Death was instantaneous.

Regarding the above clipping the Scientific American observes that,—

"Our natural desire to emulate the great scientist and statesman referred to, must be tempered by the more modern knowledge that Franklin's classic experiment was a very foolhardy one—though he did not know it....."His escape from as speedy a death as we record is perhaps proof of a discriminating Providence of those days; but no future Franklin need be lost by taking any such risks today. Better cut the string and lose the kite rather than persist in handling a wet kite string with bare hands while standing on rain soaked ground. If you use a reel for the kite-string be sure to ground it as carefully as you would any other lightning rod, stand on dry ground yourself, and leave the string alone."

A GOOD THOUGHT

From a contemporary we take the following excellent argument advanced by the proprietor of a Maryland garage on the signs that appear in most garages; "Not responsible for loss or damage by fire or theft"—but let our commentator speak:

"Why does a person travelling by auto want storage if not protection?

"As cars are used in all kinds of weather, a night outdoors would do little harm.

As the getting of supplies is common without putting the car in storage it would seem unnecessary for the purpose; small repairs the same. Risk from fire is certainly less on the street than in a garage; hence, unless the garage will say that the car and contents are safe from theft, why not leave the car in the street—as I am doing under such conditions? What else does the traveller want but protection?

"The 'Not Responsible, etc.' signs can give the idea that the place may not be very responsible for other things than theft. That is, if not enough attention is paid to prevent the common pawing over of cars and contents, it seems likely to the stranger that attention may be lacking in other lines.

"Keep away from cars not your own' is a sign much more encouraging to the stranger and probably also to the regular customer, especially if he knows the rule is enforced."

WHERE ARE THE ROADS?

Hordes of autos now remind us

We should build our roads to stay,

And, departing, leave behind us

Kind that rains don't wash away.

When our children pay the mortgage

Fathers made to haul their loads,

They'll not have to ask the question,

"Here's the bonds, but where the roads?"

—Buffalo Times.

DON'T GIVE MONEY TO AGENTS

The American Blacksmith, Auto & Tractor Shop DOES NOT employ subscription agents. Any person representing himself as such is an impostor and should be so dealt with. Notify us immediately if anyone claiming to represent this journal calls upon you.

CONTENTS—SEPTEMBER, 1919

| | |
|--|-----|
| Welding Automobile Cylinder Castings | 289 |
| Tool Post Jack, Novel Vise Punch, Cotter Pin Puller, Can Tipper | 292 |
| Art's Overland Express | 293 |
| Soldering Aluminum | 295 |
| Welding Nomenclature and Symbols | 296 |
| Gasoline Rate Table | 297 |
| Horsepower Chart | 299 |
| Benton's Recipes | 299 |
| Fitting Small Circular Saws | 302 |
| Future Tractors with Electric Starters | 303 |
| "Cashing in Your Checks" | 305 |
| Queries, Answers, Notes | 306 |
| Index to Volume 19 | 308 |



Welding Automobile Cylinder Castings

DAVID BAXTER

THE welding of an automobile engine cylinder requires no special skill or knowledge but it does require careful adherence to certain principles. The chief of which are the action and reaction of expansion and contraction. These two factors must be taken care of if a successful weld is expected. Of course a proper regulation and manipulation of the welding flame is essential also, but not so much as correct control of expansion and contraction of the metal in the casting during the welding, before and afterwards. A weld can be made that will hold even if the torch is handled carelessly but if the job is not properly expanded it will certainly crack either during the proceeding or after the welding is finished.

Other factors that go to make up a weld are the proper choice of filler, flux, tip, and gas mixture, together with a certain amount of preparation of the fracture. To illustrate these things let us take a common cylinder block and see how to do the welding. Or rather, let us see how the work was accomplished on the job illustrated in the accompanying photos. Let us take this weld a step at a time in order to make the process clear to both the novice and the more proficient torch operator. However, it will be with the supposition that all are more or less familiar with the fundamentals of the acetylene process; enough that it will not be necessary to go into details about handling the different parts of the apparatus, for which there is not space enough here.

The Job—First a brief description of the job: Picture No. 1 shows a quite common four cylinder block. The fractures are clearly defined, extending nearly the full length of the side of the casting. There are in reality three cracks because the left hand fracture is divided into two parts by the glandular orifice. Attention should be directed to the sinuous shape of the right hand crack; nowhere is it straight, a fact that is a great help in the welding as will be explained later on. The metal thickness in the

cracks average a fourth of an inch except in the gland, here it is about half an inch thick. The crack running through one bolt necessitated its removal before welding and a subsequent replacement after welding.

Preparation—A certain amount of preparation for the weld is essential on all jobs, especially cast iron work and although not always



NO. 1—EXTENT AND LOCATION OF FRACTURES

absolutely compulsory it will always be found a great benefit.

The block illustrated was prepared for welding in the following way: first, the immediate vicinity of the cracks was cleaned of all grease, dirt and paint; an inch or so of the surface was cleaned the full length of both sides of the crack. The paint and grease was burned off with the welding flame, then the scorched surface was scraped with a file until bright and bare. By being careful in the matter of cleaning the line of the weld the operator was reasonably certain that no foreign matter would enter the melting weld to be absorbed there to cause pin-holes or slaggy spots, in the finished weld.

Next, the edges of both sides of each crack were cut away with a sharp chisel and light hammer.

The thinness of the metal required care in this chipping process to prevent breaking the casting. It is probably safer to file a groove along the crack on these block jobs. However that may be, the cracks were grooved out the full depth of metal thickness all along the cracks. The groove, made in shape of a V, was cut out until it was as wide at the top as it was deep. By cutting a wide, deep groove (to the bottom of the crack) the operator was assured of being able to weld the full thickness of the casting. Which is very essential on any cast iron weld.

The sloping sides of the groove provided a way to make a well fused joint. Had the walls been steep the metal would probably have clogged the crack and resulted in a poorly connected weld; one containing spots where the new, or filler, metal was not fused thoroughly with the metal casting.

The ends of each crack were grooved back nearly an inch further than it was thought the crack extended. These end grooves were sloped gently to the surface, not ended abruptly. The ends were made narrower and shallower as they neared the surface. This permitted the welder to bring the weld to a close gradually.

All of this preparation takes quite a little time and should not be forgotten when giving an estimate on the cost of the job. In fact it often takes as much or more time to prepare a casting for welding than the actual welding and yet a weld well prepared is half welded, so, on jobs like this always clean and groove the cracks or broken edges.

Preheating Oven—After the casting was in readiness the next step was to preheat it. This was accomplished by first leveling and wedging it up on fire-brick topped welding table. Iron wedges and odd bits of iron were placed in such manner as would prevent any part of the block from tending to sag or distort. There is danger of any casting becoming distorted through sagging when red hot if all parts are not supported. Take the block

in points. Suppose it were supported at each end only, the center would probably sag enough when red hot to cause a misalignment of the cylinder base or head. Care was taken therefore to see that no part was suspended. After this was attended to a wall of fire brick was built around the entire casting as illustrated in picture No. 2. This brick oven was for the purpose of concentrating and conserving the preheating fire. It also protected the torch operator while welding. And the heat being thus closely confined caused the job to heat faster and more evenly, saving time and insuring an all-over heat, that is, the whole casting reached the proper temperature at one time.

Openings were arranged at each end of the oven through which the gas burners were inserted as the picture shows. These burners were arranged to spread the flames around each end of the block. Thus enveloping the whole casting evenly. In absence of natural gas for preheating the next best would be oil burners. Had neither gas or oil been available a charcoal fire would have been kindled around the casting inside of the wall and openings left in the brick-work to furnish air to the fire. Natural gas probably furnishes the best heat for preheating on account of the ease with which it is controlled. However, charcoal fire gives a good even heat if properly kindled.

Preheating—After the preheating device was completed as illustrated and described the burners lighted and a covering of asbestos was spread over the top of it. A few small holes were punched in asbestos to permit a free circulation of air. Notice in picture No. 2 the position of the cylinder block in the preheating oven. The casting rests on its side with the cracks upward. Some welders prefer to preheat cylinder blocks with the bore vertical. This is not necessary if the heating is properly carried out. When employing the position shown it is unnecessary to move the block after it starts to heat until the weld is finished.

The burners were allowed to burn full blast until the whole casting was bright red all over before

starting to weld. A close watch was kept during the preheating to see that the job didn't overheat. The operator raised each corner of the asbestos every few minutes to see when the heat reached the right stage. This was easily seen in the comparative darkness of the oven. By observing all angles of the job the operator could tell when and where to shift the gas flames to even up the heating.

The "Whyfor" of Preheating—The reason for any preheating as well as for this particular job is to expand the casting so that when the torch flame is applied there will be no sudden expansion in that portion, due to the intense heat of the torch flame. It is also for the

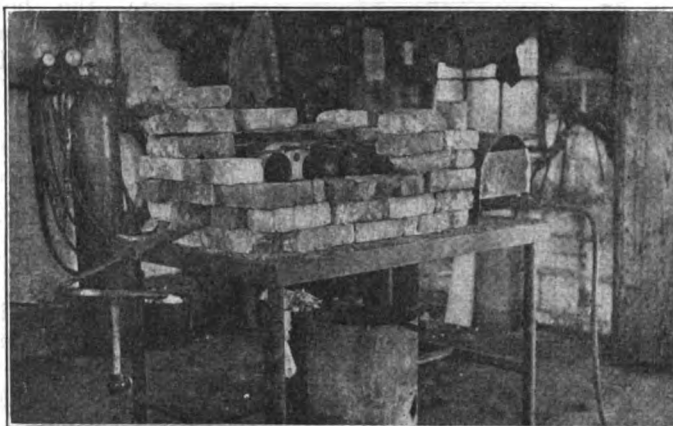

NO. 2—THE PRE-HEATING ARRANGEMENT

purpose of forestalling the effects of contraction which would take place when the weld cooled, whether it was preheated or not. If the whole block was not heated then expansion and contraction would center in the weld. The heated metal of the weld would, upon cooling, pull away through contraction from the colder and more rigid portions of the surrounding casting, resulting in a strain and more than likely an open crack. If the whole job is preheated correctly there is no opportunity for one part to pull away from the other when the contraction sets in providing the cooling occurs evenly, because the whole thing contracts in unison. We see therefore, that the main idea was to have the whole block hot and expanded by preheating before attempting to weld the cracks.

Getting Ready to Weld—While the block was preheating the welder put the little details in readiness. The little things are sometimes the means of saving or losing a weld.

Once the welding is started there should be no interruptions. Every part of the equipment should be in good working order. To facilitate the welding of the block illustrated the welder fitted a medium size tip to the torch and placed an extra one conveniently near. He chose several eight inch filler rods examining them for grease or dirt in the shape of burned molding sand, replenished the supply of flux powder, placing the pot on the table; examined the regulators and gas supply that there might be no interruptions on this score. Tongs, hammer, skimmers and a bucket of water were conveniently placed. The water for the purpose of quickly cooling the tip in case of overheating. All of these little things are mentioned merely to show how a careful welder works. Meanwhile the casting was fast becoming hot enough to start welding. Its condition was ascertained by peeping under the asbestos as previously stated.

Welding — When the block was bright red all over, a portion of the asbestos covering was torn away directly over about one-third of the length of the crack. The crooked crack to the right in picture No. 1 was attacked first. The curves in this fracture tended to distribute the expansion and contraction in divergent directions, which lessened the danger of a strain. Welding back around a curve of this kind tends to reheat the part already welded thus keeping the line hot longer so it may all equalize at once. This weld was started on the crooked crack first in order to take advantage of any play offered by the round opening in the middle of the other crack. This permitted a slight movement of the side of the block.

The crooked crack was welded an inch at a time its full length; each inch being a continuance of the preceding inch. First, the bottom of the starting point was melted together, meanwhile the end of the filler rod was heated to a melting stage. As soon as the bottom of the groove was in a melting condition the melting filler was added. The flame was kept in continuous motion, back and forth across the groove and end of the

filler rod. The filler was continually twisted in the melting weld. As fast as a drop of the filler was fused with the groove the rod was moved forward. The twisting, poking motion of the filler rod helped to mix the two metals. Flux was applied to each fraction of the line of welding by dipping the hot filler in the powder and returning it quickly to the weld.

Whenever a bit of dirt or slag appeared it was floated to the surface of the weld and consumed or flowed off by the burning flux powder. Sometimes it was necessary to pick the slag out with the filler rod.

The general direction of the flame was toward the part of the crack yet to be welded, very seldom was it directed straight toward the weld. This manipulation of the flame tended to heat the groove in readiness for the coming weld. Once in a while it was necessary to dip the end of the flame directly into the weld in order to help dislodge a stubborn bit of slag. Each succeeding inch of the weld was made by first melting together the bottom of the groove and the fusing it full of new metal. The crooked crack was handled about a third at a time. As fast as one third was done it was covered again with asbestos and a new portion uncovered. When the last third was done the whole crack was covered again and allowed to preheat for several minutes to bring up the ex-

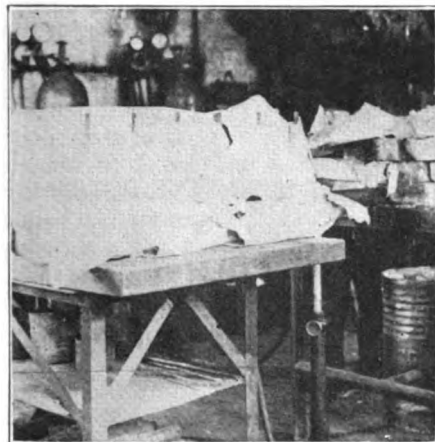

NO. 3—THE CASTING WRAPPED IN ASBESTOS PAPER FOR COOLING

pansion in event any had been lost during the welding.

When the top side of the block was once more red hot all over, the left hand fracture was welded. This was accomplished by starting at the end of the upper crack and welding toward the hole. The de-

tails of this weld was the same as for the crooked weld; a continuous, inch-at-a-time process, fluxing and mixing the whole line. Then the lower crack was handled in a like manner from the end to the round hole. By welding toward the orifice each time the welder took advantage of any play afforded by welding toward a free end. An open or free end nearly always offers a chance for expansion and contraction to work without danger of cracking back. By cracking back is meant it cracks again, either in the welded portion or a new location.

Some authorities advise a surplus metal added along the weld in all cases. But such was not done on this block. Instead, the edges of the new metal were tapered off to join the casting about level. As the welding progressed the flame was manipulated to spread and wash the melted weld level. The melted weld was literally painted into a flat, level surface by the pressure of the flame. Rough spots were brushed flat and high spots brushed toward low spots. This painting motion was employed during the welding from time to time as needed.

After the entire casting was welded and while the job was yet red hot, a long, sharp chisel was used to scrape the soft gummy substance which was formed along the edges of the weld by a mixture of slag and flux powder. This substance usually forms along the sides of the weld and may be easily cleaned off if it is done while the casting is yet hot; after it cools the stuff is very hard and tenacious.

Cooling—The last weld being finished the whole thing was covered with the asbestos paper, brick work, casting and all. Fifteen or twenty minutes were allowed for the casting to heat under cover before turning off the preheating gas. This insured an even start when the contraction set in. The idea being to have the whole block cool the same and therefor to contract the same throughout. Had one part cooled while the other was still hot a new crack would have been the result. By preventing air from reaching the job it was forced to cool slowly and evenly. The covering and brick were allowed to remain intact for several hours before moving the job. When the casting would no longer fry a small drop of water injected through an opening in the paper,

the brick oven was quickly torn away and the block completely wrapped in asbestos paper. The casting was not nearly cold yet but it was necessary to use the table for another job so the block was wrapped and moved to another place to finish cooling. Otherwise



NO. 4—THE WELDED CASTING

the block would have remained where it was welded, until cold. Picture No. 3 shows the method of wrapping the job to permit it to be removed to this table to cool. There is some danger in moving welded castings from one table to another but it is often imperative in small shops where there is not enough equipment to permit one job to cool while the other is being welded. However, the job may be moved quite hot if the work is carefully done and the casting is properly protected from cold air blasts.

Picture No. 4 shows the block ready for the machine shop, where a new bolt must be inserted in place of the one removed in welding. Some polishing must also be done on the bores of the cylinders due to the action of the preheating fire. It is well to coat the bores before heating with a mixture of oil and plumbago, or graphite. It prevents to a great extent any injury of the metal in the bore.

Finishing—This block needed but little finishing after it was cold due to the scraping and hot finishing while welding. However, it was given a neater appearance by grinding the rough spots off with an emery wheel.

Perhaps, in closing a few words on overheating a job will not be out of place. While the job is preheating watch it closely to see that no part of it reaches the melting

point. If the iron commences to turn white hot it is getting too hot. When cast iron reaches the white stage it enlarges and distorts or swells in places. A bright glowing red is sufficient.

TOOL POST JACK

When cutting off large diameter stock in the lathe it is necessary to use a long blade in cutting off tool and it has been found that to use a jack bolt under the tool near the blade, as shown in the sketch, will

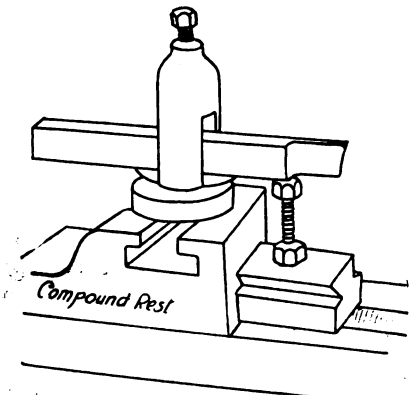

TOOL POST JACK

stop the tool from vibrating, thus reducing the danger of digging in or jamming and breakage. This same idea can be applied to tools that chatter when cutting. The jack bolt is just a regular stock bolt cut the right length so that the bolt can be unscrewed from the nut just enough to tighten the tool and support it.

NOVEL VISE PUNCH

A novel type of small punch can be made for the bench vise from

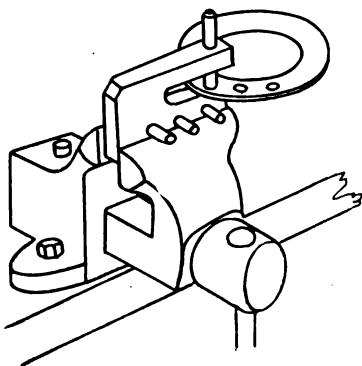

VISE PUNCH

small pieces of boiler plate or other scrap metal, as shown in the drawings. The piece of plate is used edgewise. A hole is drilled for the largest size punch which for 7/8-

inch plate is 5/8 inches, then a slot B is cut to receive the work to be punched. Next the steady or support pins C are put through the plate. These keep the punch solid and firm in the jaws of the vise

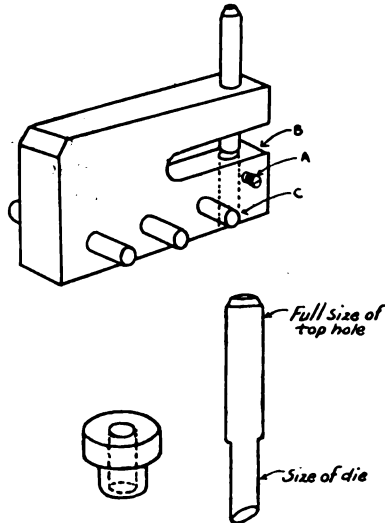

PUNCH DETAILS

when using it. A set of dies can be made for the smaller size punches, as shown. These are held by the screws A. If one has not the equipment to make the dies, then a set of the punch plates could be made for the sizes one needs, making the punch hole to suit each size needed. These punches can be used for all thin stock and gasket material.

EASY MADE COTTER PULLER

The material from which in a couple of minutes time this cotter pin puller is made can be found around any shop, namely, an old

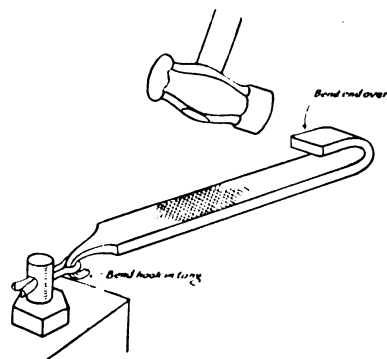

COTTER PIN PULLER

file, and it makes a dandy tool to have in one's kit. The tang or handle end of the file is bent into a hook shape, and the other or square end of the file is simply bent around at 180 degrees and forms a shoulder on which to strike

the hammer blows that extract the cotter pins when the tool is hooked into the eye of one, as shown in the sketch.

OIL CAN TIPPER

This stand is made from odds and ends of stock and is very simple of construction. I made one for use in the shop and since then have had to make several for customers who wished one for their garage. I have drawn both assembled and detail views of the

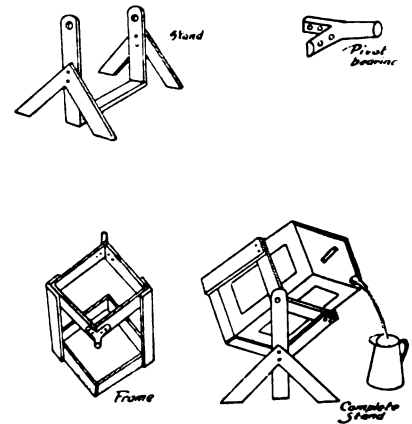

FOR POURING CANS

stand so that any reader may make one from these views. 1/4 x 3/4 or 5/16 x 1 inch stock is suitable for use in making it and making them provides a good way of using up small lengths of flat bar stock. The base of the frame is made of angle iron, as are the two vertical corner pieces. The pivot bearing is made by splitting lengthways short pieces of round stock, spreading and drilling.

HANDLING TIRE BOLTS

When removing buggy tires the bolts are often found to be loose and turn round. Sometimes they are rusted into the tire and cannot be punched out. To overcome these difficulties, the smith can make a very thin cold chisel and sharpen it on one side like a wood chisel. Get it down on the bolt between the tire and the rim, the sharp side of the chisel against the tire, and cut the bolt off. When the tire is off, punch the bolts out of the rim. If you are in the habit of always putting in new bolts when cutting tires, this is a much quicker plan than unscrewing the nuts and punching out—this is, if you do not intend to use the old bolts again.

Art's Overland Express

D. G. BAIRD

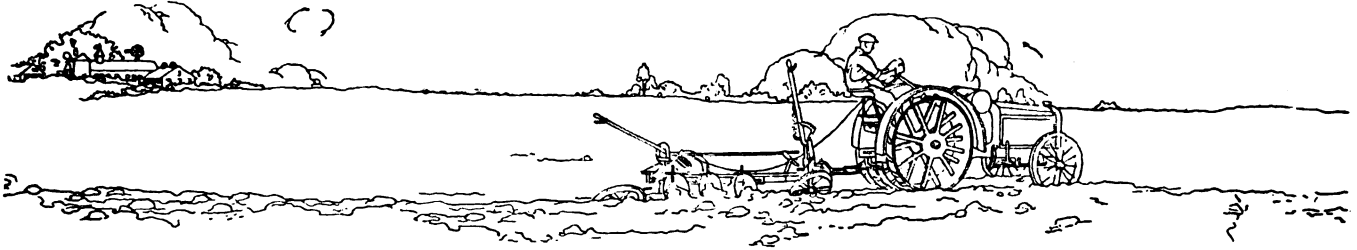

I always make it a point never to claim any credit that don't rightfully belong to me. No, sir; I may be guilty of several questionable practices — such as smoking and admiring Charlie Chaplin and Ty Cobb—but I'm always glad to grant honor to whom honor is due, as Milton said. F'rinstance, I was enthusiastically in favor of Woody's going over to Europe and straightening things out long before he announced his intention of conforming to my wishes in the matter, but did I claim any credit for it? No sir-ee Not one single credit did I claim.

But as I said, in quoting the great statesman above, "honor to whom honor is due"—even if it happens to be yours truly. If Art Tinsley don't make me a present of a diamond sunburst or remember me handsomely in his will—but I'm getting ahead of my story.

I was down at Marysville and found one of these Chautauquas in town and, as I've always been a liberal patron of fine arts, I condescended to honor the performance with my presence. All the merchants had closed up and gone and there wasn't a customer to custom me, but of course I'd have gone anyway. Well, about the time I was beginning to appreciate a rough board seat without any back, the boss of the concern leads out a congressional-investigationish looking individual in a claw-hammer coat and white string-tie and introduces him as the "Right Honorable—"I don't remember the name—and takes about fifteen minutes to tell us what a great orator the said right honorable is, and then the aforementioned right honorable detains us for the rest of the afternoon telling us about the opportunities "of our great and glorious land of liberty and equal-

ity, et cetera." His subject is "Turning The Water of Life Into Liquor"—maybe he said "wine", it doesn't matter anyway; I'm sure it was some kind of booze—and he sure did make us feel like going out and getting a drink and picking up a million dollars or so.

I'm always as optimistic as a flea on a shaggy cur's back—as all my friends and creditors well know—but when I gets outa that Chautauqua I'm so enthusiastic I could turn **money** into liquor, only I remembers this is the year of the independence of the U. S. the one hundred and forty I forget how many, and of national prohibition the first, so I goes down to the garage and has a chat with Art Tinsley instead.

But it seems like the lecture hasn't done Art as much good as it has me, and when I slaps him on the back and inquires confidentially why he don't get rich and get married, he wants to know where I got it.

"Yeh, it's all mighty fine," he says real sarcastic, "to talk about these here ginks that've got rich and succeeded in spite of everything, but how did they do it? Answer me that!" And without waiting for me to answer as he'd just asked me to do, he goes on, "How'd John D. get his dough? W'y by gettin' in on oil just when candles was goin' outa style. And Carnegie? By gettin' in on steel just before the Woolworth buildin' is commenced. And J. P.—"

"But my dear boy," I remonstrates earnestly, "that's not saying a word against my argument which is, namely, that for fighting and making money and grafting in politics this fair land of ours has got the world beat. Now there's Henry Ford, f'rinstance—"

"Oh sure!" Art butts in, "but them's all exceptional cases just

like that lecture man dug up and we pay him a dollar for tellin' us about 'em and stay poor ourselves. Take it from me, this here 'wine o' life that most of us have got to drink is pretty much diluted with water.'

"But how about Edison and William Wrigley and Jess Willard?" I comes back. I'd have had him admitting that the wine of American life at least would stand the food and drugs inspection test, but just here Salisbury, who's proprietor of the Hull House, puts in with some of his pessimism.

"I'll tell you how to get rich an' famous both," he says whittling away on a white-pine stick, "find out some way t' beat the high cost o' livin' an'—"

"I'll see to that pronto, Mr. Salisbury," I interrupts politely. I don't like to hear hotel men talk about the high cost of living. It reminds one unpleasantly of raises in hotel rates. But the subject wasn't to be dropped so easy. There's a stranger there—a man with a Fatty Arbuckle shape and a comedy nose—and he joins in: "Trouble is us farmers what raise the truck ain't the ones what's gettin' the money. You folks here in Maryville 're payin' \$1.75 for potatoes and 75c for butter and 55c for aigs an' all that, but what're us folks what raises the truck gettin' for it? We're gettin' 90c for potatoes and 40c for butter and 25c for aigs and—"

"Just a minute, Roscoe I says, "would you mind divulging the secret of your place of abode? I mean where do you reside, lodge, dwell, roost, perch, sojourn, or tarry permanently," I hasten to add as he looks suspiciously in my direction.

"I live down Arden way, thirty mile from here. We folks

down there can't afford to haul our truck to Maryville—it's too far—so we have to sell it to them commission men for what they're minded to pay and they ship it to the big cities and charge what they please for it. Last year one of them fellers bought ten acres o' tomatoes from me in the field and nary a tomato did he ship—just let 'em all stay there and rot ruther'n flood the market and bring the price down!"

I looks at Art meaningly, but he don't seem to catch on so I interrogated the honest tiller of soil; "And what have you for disposal at the present time and what remuneration in terms of good hard American kale would you be willing to consider in exchange therefor?" He seems to be a peculiar kind of gentleman and begins to edge off up the street when Art adds that I want to know what he's got to sell and what he'll take for it.

Well, it appears that he's got about a car load of peaches and some tomatoes, potatoes, butter, eggs, and other fruit of his horny-handed toil that he's planning to sell to the commission men the next day, so I tells him Art'll be glad to take the whole lot and pay cash for it. He's glad to make the deal and says there are a lot of other splendid agriculturists who'll be glad to sell to us and get ahead of the commission men and I slips him a eagle and shoves him gently off up the street.

But Art ain't none too pleased with my efforts in his behalf and begins as if he's peeved; "Now looka here yuh frenzied financeer, how in the world am I goin' to get all that truck and what'm I goin' to do with it if I do get it? I ain't got a truck to my name nor the money to buy one nor the money to pay that old geezer for his stuff—"

I very gently, but firmly, sets him down on an empty soap box and very carefully elucidate: "Here's about a million dollar business just begging you take it, old man. You know what prices are here and you just heard Mr. Arbuckle, or whatever his name is, say what he'd take for the same right in the field ready to be pick-ed. Now with a five-ton gas-wagon and trailer hung on behind you can make the round trip to Arden and intermediate points every day in the week and have time to complain at the cook for not having supper ready when you come in—"

"But where am I to get the trucks and the money," Art breaks in with tears in his eyes.

"On the down trip," I goes on without deigning to notice his bad manners in interrupting me, "you can haul sewing machines and chewing tobacco and lawn mowers and tooth-picks and calico and knitting needles and sugar and vacuum cleaners and electric washing machines—charging one cent for each hundred pounds for a mile, with a minimum charge of



ALWAYS ACCOMMODATING, ED. ROBINSON SHOWS OUR PHOTOGRAPHER HOW HIS WIAVER TIRE CHANGING MACHINE WORKS. IT STANDS IN FRONT OF HIS SHOP AND ALL ARE WELCOME TO ITS USE. THIS IS ONE OF THE REASONS THAT ED'S SHOP IS ONE OF THE MOST POPULAR IN HIS PART OF PENNSYLVANIA

twenty-five cents, and coming back you can bring a load of pigs and eggs and apples and potatoes and peaches and everything that's good for the hungry Marys of Marysville; and you can pay the farmers a better price than the commission men and sell to the sophisticated citizens cheaper than they can buy anywhere else and—oh well can't you see the nose on your face?"

Art looked like his best friend had just died instead of his just having met dame fortune face to face. "For the last time," he says resignedly, "I ask you where am I to get the trucks and the money?"

I'd been so busy figuring profits that I hadn't taken time to think about that, but I don't let on to

Art in the least. I got up and took a stroll through the garage, Art tagging along and repeating his monotonous question. There's quite a number of cars in the shop; some for repairs, some that've already been repaired, and some that's just being kept there. I sizes them all up and then I turns to Art and says casual like, "how many drivers can you scare up for a little spin tonight?"

He looks mean and says he can get more drivers than he can cars for them to drive, and I says confidently, "you just around up the drivers and I'll take the responsibility for getting something for them to drive." And with that I hustles him off, refusing to answer any questions at all.

Well, about two o'clock that night the strangest procession of gasoline vehicles that ever went down a pike slipped out of Marysville without seriously disturbing the peaceful slumbers of the citizens and heads for Arden and in the morning they come back loaded to the axles with the products of mother earth.

We had to buy his old hearse from Elison the undertaker—he swore nobody would ever again agree to be hauled to the cemetery in it—but I managed to smooth things over with the mayor about the fire truck. As for the others—well, I always have a supply of Havanas on hand and most folks can see a joke anyhow if it's carefully pointed out to them.

That's how Art Tinsley came to start his now well-known and highly appreciated (as well as highly-remunerative) Overland Express. As I said in the beginning; I'm a modest and unassuming man, but "honor to whom honor is due," as George said when he changed Black Jack Pershing's name to Sir John.

DON'T LEAVE YOUR SWITCH ON

The above warning is not intended to be a remark made at a hairdresser's, but in an automobile service station. It refers to the battery system on a car. If the switch is left on all night, or for a few hours during the day, the battery will discharge its electric current, perhaps run down, buckle the plates, and do other serious and costly damage.

It does not appear where a magneto alone is used, for a magneto never causes worry or gives trouble in this particular, but where a battery is used for starting and lighting it should be kept in mind.

SOLDERING ALUMINUM

David Baxter

UNTIL the last few years the soldering of aluminum has been considered by many very difficult if not well nigh impossible. In fact, today, there are many mechanics who know nothing whatever about it, despite the fact that there are several good aluminum solders on the market. And there are several reliable formulas to be had whereby the mechanic can make his own solder, two of which will be given farther along in this article. It is sometimes better to remelt purchased solder and run it in smaller sticks, because the commercial bars are frequently two large and clumsy for convenience.

Aluminum soldering is not difficult and there are times when it is desirable, so much so that most repairmen will find it an advantage to know how to do it. It is a fact though that aluminum soldering does not compare favorably with welding; it is not recommended as a substitute for welding. It will not have the strength nor pliability of a welded joint. And should not be resorted to when it is possible to weld. In absence of a welding apparatus, however it may be used with fair results, especially if the parts to be soldered are not subjected to strains or pressure. Where it is merely desired to stop leaks or fasten together small parts, aluminum solder can be used to advantage.

To combine the two methods, welding and soldering, is perhaps the better way. That is, to do the soldering with a welding torch. Or, with a special soldering torch instead of soldering iron. This torch is similar to a welding torch except that it uses no oxygen and such a torch may be obtained from most manufacturers of welding equipment. In event of not being able to secure a special soldering torch, however, the mechanic may employ the welding torch if he uses a very small tip, or nozzle. Even then the small white cone of flame should not be allowed to come in direct contact with the solder. The outer brush or envelope of flame will be sufficient to melt the solder. Then, the repairman must be especially careful on thin metal.

By way of illustrating the process of soldering aluminum, take for example a well known article and follow the method; such as a cracked oil pan of an automobile.

Here is something that may be soldered with a fair degree of success. And which will give satisfactory results if properly executed.

Repairs of this nature are only required to be oil tight, coming under no sudden exertion or strain. It must not be supposed that the soldered crack will possess the strength of the surrounding casting; a moment's thought will convince anyone that this could not be, since soldering is "sticking together" while welding is casting in one piece.

With the understanding that the welding torch is to be used the soldering is accomplished about as follows: first, the crack is beveled or grooved out to an angle of nearly 90 degrees. That is, the sides of the crack are cut sloping so that the crack is about as wide at the top as the thickness of the metal. The groove to extend to the full depth of the crack. This part of soldering is the same as though the crack were to be welded.

Next the crack and its vicinity should be cleaned thoroughly with a file and wire brush. The surface should be scraped bare and bright. It helps with the cleaning if the crack is warmed slightly before brushing.

When clean and bright the casting is placed level upon a welding table or other convenient support. The groove is situated as nearly horizontal as possible, this is to prevent the solder from overflowing too much.

It is sometimes an advantage to preheat a section of the casting around the location of the crack by means other than the torch flame. However this is not absolutely necessary in most cases. If only the torch is used the flame is passed around in an increasing circle over the vicinity of the crack, until a space about a foot in diameter is fairly hot; this is for the purpose of preventing any chance of sudden expansion when the solder is applied.

Everything in readiness the brush of flame is passed up and down the crack until it is hot. Then the end of the stick of solder is rubbed along the groove until a thin skin of it adheres to the sides of the groove. Then the surface of the groove is once more rubbed with the wire brush, vigorously until the entire groove is coated with solder.

Next, the torch is moved along

the groove until it is hot enough to melt the solder, a stick of which is rubbed along the groove following the flame. The groove is melted full of solder with a slight surplus above the level of the casting. As soon as the surplus commences to set it is pressed and flattened out in the groove, packed, as it were. After some practice the welder will not find it hard to give the solder a neat, solid appearance with a piece of smooth, flat hickory. When the crack is soldered complete the job is allowed to stand until almost cold before moving.

When a soldering iron is used instead of the torch the only difference will be in the manner of warming the groove. This is accomplished by means of a common tinner's blow torch, or with a natural gas jet, the solder being melted into the groove with the hot iron.

Manufacturers of aluminum solder will gladly furnish other little details that may be needed to use their particular brand of solder. In the main, however, these may be worked out by an ingenious mechanic. Some times a flux is needed, at others it is immaterial.

One formula that is used by a large electrical concern is as follows: 75.5 parts of tin by weight, 18. parts of zinc, 2.5 parts aluminum; no flux.

Another one is: 80% tin, 20 % zinc; Stearic acid flux.

In recapitulation: As two pieces to be soldered must be thoroughly alloyed with the material used as solder, the temperature must be raised and maintained at such point that inter-fusion can be effected.

It is essential that the surfaces to be joined are perfectly clean. In some instances means must be provided to prevent or break oxidation, because oxide tends to prevent inter-fusion, or at least minimize it. The use of flux that excludes air, and that contains a substance having a solvent action on oxide is to be recommended.

After the soldering is complete, steps should be taken to prevent or lessen subsequent corrosion of the metals. This corrosion may not be evident for some time after, but will eventually show if nothing is done to counteract it.

A dime to many a young American does not mean 2 nickles or 10 pennies. Money to American youth has value only in that it immediately buys something. Money spent unwisely is gone forever; money put in Thrift Stamps and W. S. S. returns with more.

Welding Nomenclature and Symbols

In order to aid in the standardization of the various types of joints and welding operations the nomenclature prepared by the Welding Committee of the Emergency Fleet Corporation, United State Shipping Board is given. It is suggested that general use be made of it in

Also used for filling through a bolt hole as at (Figure "C"), or for added strength when fastening fixtures to the face of a plate by drilling a countersunk hole through the fixtures (Figure "D") and applying the welding material through this hole, as at (Figure

welded from the side of the work opposite the reinforcement, and the reinforcement, of whatever shape must be welded from the side of the work to which the reinforcement is applied.

Tee weld is one where one plate

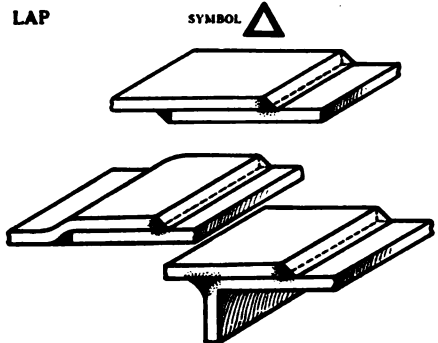
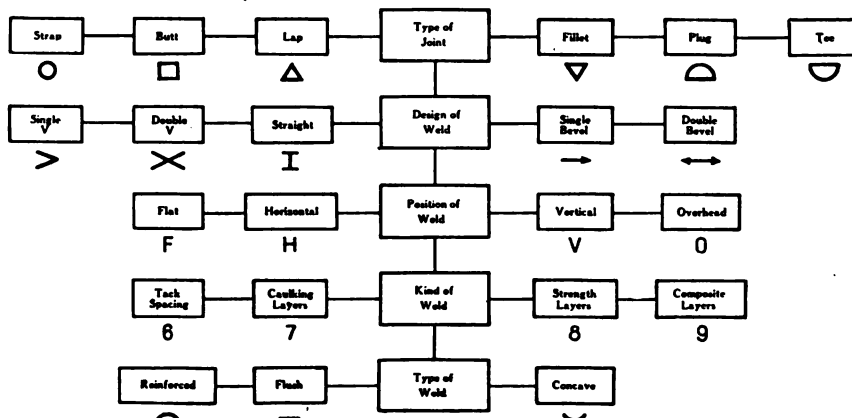

is welded vertically to another as in the case of the edge of a transverse bulkhead (Figure "A"), being welded against the sheelplating or deck. This is a weld which in all cases requires **exceptional** care and can only be used where it is possible to work from both sides of the vertical plate. Also used for welding a rod in a vertical position to a flat surface, as the rung of a ladder (Figure "C"), or a plate welded vertically to a pipe stanch-

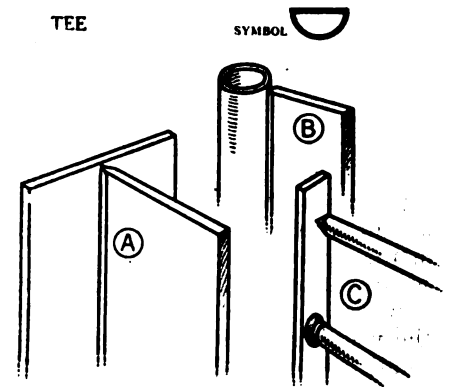
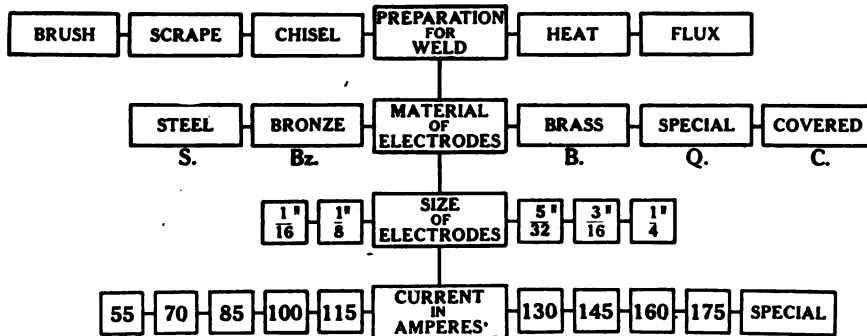

ion (Figure "B"), as in the case of water closet stalls.

Fillet weld is one in which some fixture or member is welded to the face of the plate, by welding along the vertical edge of the fixture or member (see "welds" shown and marked "A" on illustration at left). The welding material is applied in the corner thus formed and

the industrial world so that all may speak the same welding terms in the field or shop. The nomenclature is given as follows:

Plug weld is one used to connect the metals by welding through a hole in either one plate (Figure "A") or both plates (Figure "B").

"D") thereby fastening the fixture to the plate at this point.

Strap weld is one in which the seam of two adjoining plates or surfaces is reinforced by any form or shape to add strength and stability to the joint or plate. In this form of weld the seam can only be

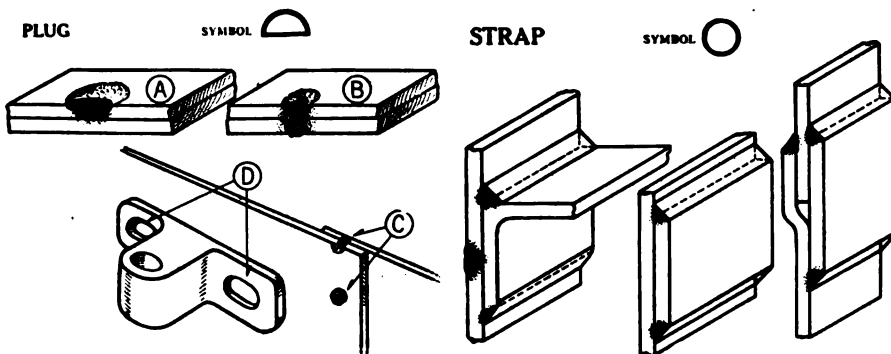

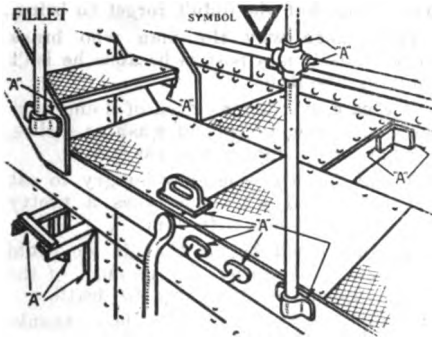

finished at an angle of forty-five degrees to the plate.

Single "V" is a term applied to the "edge finish" of a plate when this edge is beveled from both sides to an angle, the degrees of which are left to the designer. To be used when the "V" side of the plate is to be a maximum "strength" weld, with the plate setting vertically to

the face of adjoining member, and only when the electrode can be applied from both sides of the work.

Butt weld is one in which two plates or surfaces are brought together edge to edge and welded along the seam thus formed. The two plates when so welded form a perfectly flat plane in themselves, excluding the possible projective caused by other individual objects

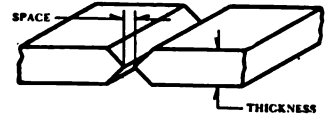
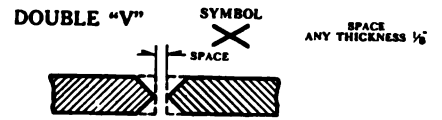

SINGLE "V" SYMBOL $>$ SPACE ANY THICKNESS $\frac{1}{2}$

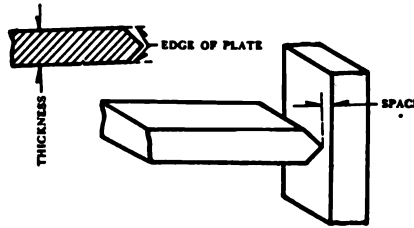

"strength" weld. Only to be used when welding can be performed from both sides of the plate.

Straight is a term applied to the "edge finish" of a plate, when this edge is left in its crude or sheared state. To be used only where maximum strength is not essential, or unless used in connection with strap, stiffener or frame, or where it is impossible to otherwise finish the edge. Also to be used for a "strength" weld, when edges of two plates set vertically to each other—as the edge of a box. (To be continued)

BUTT SYMBOL \square

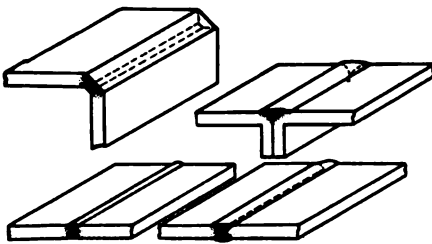

as frames, straps, stiffeners, etc., or the building up of the weld proper.

Double "V" is a term applied to the "edge finish" of two adjoining plates when the adjoining edges of both plates beveled from both sides to an angle, the degrees of which are left to the designer. To be used when the two plates are to be "buted" together along these two sides for a maximum

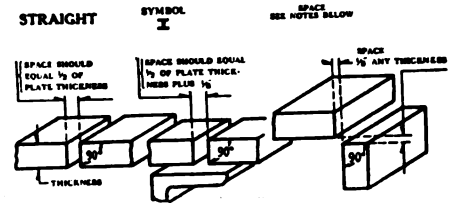

Gasoline Rate Table

| Cents per gal. | 2 | 3 | 4 | 5 | 6 | 7 | 8 | 9 | 10 | 11 | 12 | 13 | 14 | 15 | 16 |
|----------------|-----|------|------|------|------|------|------|------|------|------|------|------|------|------|------|
| 25 | .50 | .75 | 1.00 | 1.25 | 1.50 | 1.75 | 2.00 | 2.25 | 2.50 | 2.75 | 3.00 | 3.25 | 3.50 | 3.75 | 4.00 |
| 25½ | .51 | .77 | 1.02 | 1.28 | 1.53 | 1.79 | 2.04 | 2.30 | 2.55 | 2.81 | 3.06 | 3.32 | 3.57 | 3.83 | 4.08 |
| 26 | .52 | .78 | 1.04 | 1.30 | 1.56 | 1.82 | 2.08 | 2.34 | 2.60 | 2.86 | 3.12 | 3.38 | 3.64 | 3.90 | 4.16 |
| 26½ | .53 | .80 | 1.06 | 1.33 | 1.59 | 1.86 | 2.12 | 2.39 | 2.65 | 2.92 | 3.18 | 3.45 | 3.71 | 3.99 | 4.24 |
| 27 | .54 | .81 | 1.08 | 1.35 | 1.62 | 1.89 | 2.16 | 2.43 | 2.70 | 2.97 | 3.24 | 3.51 | 3.78 | 4.05 | 4.32 |
| 27½ | .55 | .83 | 1.10 | 1.38 | 1.65 | 1.93 | 2.20 | 2.48 | 2.75 | 3.03 | 3.30 | 3.58 | 3.85 | 4.13 | 4.40 |
| 28 | .56 | .84 | 1.12 | 1.40 | 1.68 | 1.96 | 2.24 | 2.52 | 2.80 | 3.08 | 3.36 | 3.64 | 3.92 | 4.20 | 4.48 |
| 28½ | .57 | .86 | 1.14 | 1.43 | 1.71 | 2.00 | 2.28 | 2.57 | 2.85 | 3.14 | 3.42 | 3.71 | 3.99 | 4.28 | 4.56 |
| 29 | .58 | .87 | 1.16 | 1.45 | 1.74 | 2.08 | 2.32 | 2.61 | 2.90 | 3.19 | 3.48 | 3.77 | 4.06 | 4.35 | 4.64 |
| 29½ | .59 | .89 | 1.18 | 1.48 | 1.77 | 2.07 | 2.36 | 2.66 | 2.95 | 3.25 | 3.54 | 3.84 | 4.13 | 4.43 | 4.72 |
| 30 | .60 | .90 | 1.20 | 1.50 | 1.80 | 2.10 | 2.40 | 2.70 | 3.00 | 3.30 | 3.60 | 3.90 | 4.20 | 4.50 | 4.80 |
| 30½ | .61 | .92 | 1.22 | 1.53 | 1.83 | 2.14 | 2.44 | 2.75 | 3.05 | 3.36 | 3.66 | 3.97 | 4.27 | 4.58 | 4.88 |
| 31 | .62 | .93 | 1.24 | 1.55 | 1.86 | 2.17 | 2.48 | 2.79 | 3.10 | 3.41 | 3.72 | 4.03 | 4.34 | 4.65 | 4.96 |
| 31½ | .63 | .95 | 1.26 | 1.58 | 1.89 | 2.21 | 2.52 | 2.84 | 3.15 | 3.47 | 3.78 | 4.10 | 4.41 | 4.73 | 5.04 |
| 32 | .64 | .96 | 1.28 | 1.60 | 1.92 | 2.24 | 2.56 | 2.88 | 3.20 | 3.52 | 3.84 | 4.16 | 4.48 | 4.80 | 5.12 |
| 32½ | .65 | .98 | 1.30 | 1.63 | 1.95 | 2.28 | 2.60 | 2.93 | 3.25 | 3.58 | 3.90 | 4.23 | 4.55 | 4.88 | 5.20 |
| 33 | .66 | .99 | 1.32 | 1.65 | 1.98 | 2.31 | 2.64 | 2.97 | 3.30 | 3.63 | 3.96 | 4.29 | 4.62 | 4.95 | 5.28 |
| 33½ | .67 | 1.01 | 1.34 | 1.68 | 2.01 | 2.35 | 2.68 | 3.02 | 3.35 | 3.69 | 4.02 | 4.36 | 4.69 | 5.03 | 5.36 |
| 34 | .68 | 1.02 | 1.36 | 1.70 | 2.04 | 2.38 | 2.72 | 3.06 | 3.40 | 3.74 | 4.08 | 4.42 | 4.76 | 5.10 | 5.44 |
| 34½ | .69 | 1.04 | 1.38 | 1.73 | 2.07 | 2.42 | 2.76 | 3.11 | 3.45 | 3.80 | 4.14 | 4.49 | 4.83 | 5.18 | 5.52 |
| 35 | .70 | 1.05 | 1.40 | 1.75 | 2.10 | 2.45 | 2.80 | 3.15 | 3.50 | 3.85 | 4.20 | 4.55 | 4.90 | 5.25 | 5.60 |
| 35½ | .71 | 1.07 | 1.42 | 1.78 | 2.13 | 2.49 | 2.84 | 3.20 | 3.55 | 3.91 | 4.26 | 4.62 | 4.97 | 5.33 | 5.68 |
| 36 | .72 | 1.08 | 1.44 | 1.80 | 2.16 | 2.52 | 2.88 | 3.24 | 3.60 | 3.96 | 4.32 | 4.68 | 5.04 | 5.40 | 5.76 |
| 36½ | .73 | 1.10 | 1.46 | 1.83 | 2.19 | 2.56 | 2.92 | 3.29 | 3.65 | 4.02 | 4.38 | 4.75 | 5.11 | 5.48 | 5.84 |
| 37 | .74 | 1.11 | 1.48 | 1.85 | 2.22 | 2.59 | 2.96 | 3.33 | 3.70 | 4.07 | 4.44 | 4.81 | 5.18 | 5.55 | 5.92 |
| 37½ | .75 | 1.13 | 1.50 | 1.88 | 2.25 | 2.63 | 3.00 | 3.38 | 3.75 | 4.13 | 4.50 | 4.88 | 5.25 | 5.63 | 6.00 |
| 38 | .76 | 1.14 | 1.52 | 1.90 | 2.28 | 2.66 | 3.04 | 3.42 | 3.80 | 4.18 | 4.56 | 4.94 | 5.32 | 5.70 | 6.08 |
| 38½ | .77 | 1.16 | 1.54 | 1.93 | 2.31 | 2.70 | 3.08 | 3.47 | 3.85 | 4.24 | 4.62 | 5.01 | 5.39 | 5.78 | 6.16 |
| 39 | .78 | 1.17 | 1.56 | 1.95 | 2.34 | 2.73 | 3.12 | 3.51 | 3.90 | 4.29 | 4.68 | 5.07 | 5.46 | 5.85 | 6.24 |
| 39½ | .79 | 1.19 | 1.58 | 1.98 | 2.37 | 2.77 | 3.16 | 3.56 | 3.95 | 4.35 | 4.74 | 5.14 | 5.53 | 5.93 | 6.32 |
| 40 | .80 | 1.20 | 1.60 | 2.00 | 2.40 | 2.80 | 3.20 | 3.60 | 4.00 | 4.40 | 4.80 | 5.20 | 5.60 | 6.00 | 6.40 |
| 40½ | .81 | 1.22 | 1.62 | 2.03 | 2.43 | 2.84 | 3.24 | 3.65 | 4.05 | 4.46 | 4.86 | 5.27 | 5.67 | 6.08 | 6.48 |

The price per gallon in cents is shown in the vertical column of black face figures and the horizontal line of figures shows the number of gallons. Where the result comes out in fractions of a cent the table shows the next regular cent.

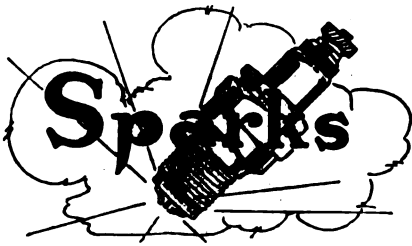

GOLLY, LADIES

When I go to the beach to swim,
I cause a mild sensation,
I'm lean of face and spare of limb—
In fact—a revelation
To those who wonder how a man
Can live and be so skinny,
A giggle comes from Mary Ann,
And Sue and Kate and Minnie.

Yet Mary Ann, with corsets off,
Is anything but pretty,
And Sue, who seems to love to scoff,
Looks like a crumpled city,
While Kate and Minnie are a team
Of faded sort of swimmers,
Without their powder and cold cream
To naught their beauty simmers.

Oh, why should women be so proud
In Sunday-go-to-meeting,
When bathing costumes show the crowd
That they've been judging, cheating?
To see me on the beach at play
Is worth a lot of money,
But women, I'm constrained to say,
Look seven times as funny.

Even the soldier boy who has never
been christened can make a name for him-
self in the army.

Accepting gratuitous advice proves that
the fellow who gets something for noth-
ing may pay dearly for it.

Things are not always what they seem.
You can save yourself a lot of trouble by
not borrowing any.

It's one thing to get the girl, but quite
another matter to know when to let go.

You can't tell an angel cake by its
wings.

Adam and Eve had much to contend
with. They couldn't even blame their
downfall on heredity.

Those little amateur performances for
charity certainly demonstrate that charity
covereth a multitude of sins.

The long and short of it is that when
a man is short he is apt to pull a long
face.

The fellow who sings his own praise is
about as melodious as a hen cackling over
her last egg.

Some people are naturally shy, but they
are never quite so shrinking as your last
dollar bill.

Even the oculist despairs of the man
who is looking for trouble while blind to
his own interests.

It all depends on the point of view. A
bird in the hand may be worth two in
the bush, but you can't make the bird be-
lieve it.

After a woman gets on a train she has
a good worry over how terrible it would
have been if she had forgotten to bring

everything that she didn't forget to bring.

The reason why the man who brags
about himself is a pest is because he isn't
bragging about us.

If a man ever got as tired of doing any-
thing as a woman gets of washing dishes,
he'd probably jump into the river.

A man has to be mighty hungry to eat
a hearty meal when he takes a pretty
girl out to dinner with him.

Another cinch bet is that if we could
see ourselves as others see us most of the
photographers would starve to death.

If a philosopher is a man who is thank-
ful for what he doesn't get, there are
mighty few philosophers.

Every good speller uses a dictionary
until it is raggedy looking. The poor
spellers are the fellows who are ashamed
to be caught looking up a word in the
dictionary.

Ain't it funny how a new straw hat
can keep a girl's legs warm on a chilly
day in March?

Do you know why so many pretty girls
marry homely men? The reason is that
any man who is good to a woman will
look handsome to her, no matter how
homely he may be.

We do not know much. But we do know
that the surest way to be disappointed
is to trust to luck.

A man laughs at an ostrich and then
the same man will close his eyes to his
own faults and imagines that other folks
can't see them.

No, we don't think that planting trees
on Arbor day should be considered as a
shady transaction.

A whole lot of perfectly good sugar is
wasted in this country in an effort to
make the cranberry taste like something
fit to eat.

It's one thing to bank on the future, but
it's quite another matter to draw checks
against it.

After July 1 the average man will have
more difficulty than ever in keeping his
head above water.

Don't let your opportunities die of mal-
nutrition. The fatter the job the more it
has to be nursed.

The sketch artist may draw on his
imagination, but nevertheless he prefers
Bristol board.

Even the fellow with an impediment in
his speech may have views that are deci-
dedly pronounced.

A contest is never one-sided when you
have a bet on the winning side.

Any wife should be happy on an income
of \$5000 a year, especially if she is spend-
ing \$8000.

Tell a girl you would die for her, and
the first thing you know you will be eat-
ing her angel cake.

It's easy enough to take the conceit out
of a fellow, but the trouble is to know
what to do with it.

The young man who thinks he is mar-
rying an angel will be surprised to dis-
cover that she needs clothes.

It is just as well to go slow in making
international alliances. Those who marry
in haste repent at leisure.

It is quite possible to have too much of
a good thing. The time may come when
women will have more rights than they
know what to do with.

In the League of Nations there will be
no place for "bushers."

It pays to advertise, but don't squander
all your appropriation advertising for
trouble.

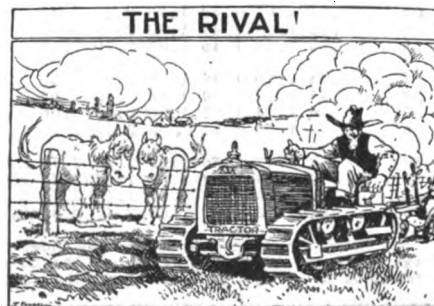

Some times it takes a man fifty years
to learn that nobody is interested in his
hard luck stories.

Don't take everything for granted.
Leave a little for the other fellow.

The soldier boy may have cigarette
stains on his fingers but his conscience is
clear.

U. S. also stands for universal salvation.

It's a good plan not to jump at conclu-
sions till you have safely measured the
distance.

Inactivity means stagnation. The fel-
low who puts his best foot forward isn't
apt to get cold feet.

Would you say a fellow takes a tumble
to himself when he trips over his own
bluff?

When a woman notices that the woman
next door has a union suit drying on the
line, a switch of store hair on the bath
room window and a pair of white shoes
drying on the back porch, she knows that
the woman next door is going down town
that afternoon.

You can make a will that will keep
your relatives from participating in your
estate. But you can't make a will that
will keep the lawyers from participating
in it.

There is a bright side to everything. If
it weren't for his rheumatism an old man
would be a whole lot more lonesome than
he is.

The old fashioned Juliet used to want
her Romeo to stand beneath her balcony
all night and sing love. But the modern
Juliet expects her Romeo to take her to a
cocktail cabaret and spend the night listen-
ing to jazz music.

Even when the cow kicks the bucket it's
no use to cry over spilled milk.

It isn't so bad to be a dreamer provided
you don't suffer from nightmares.

Experience is the best teacher and
Uncle Sam is a pretty good school master.

Gussler was passing a grain field—a
field of rye. At any rate my eyes can
drink in the landscape," he murmured
bitterly.

Many a man is more polished than his
shoes would indicate.

No, it isn't always modesty that causes
people to be shocked when confronted by
the truth.

How would a guess that hostilities
cease in thirty days sound.

You never can tell—many a man's
photograph is well developed when he
isn't.

Youth will have its fling. But that is
no reason why it should throw its chance
away.

It takes more than a peace note to
demonstrate that the pen is mightier than
the sword.

NOVEL TEST FOR PROVING TRACTOR CONTROL

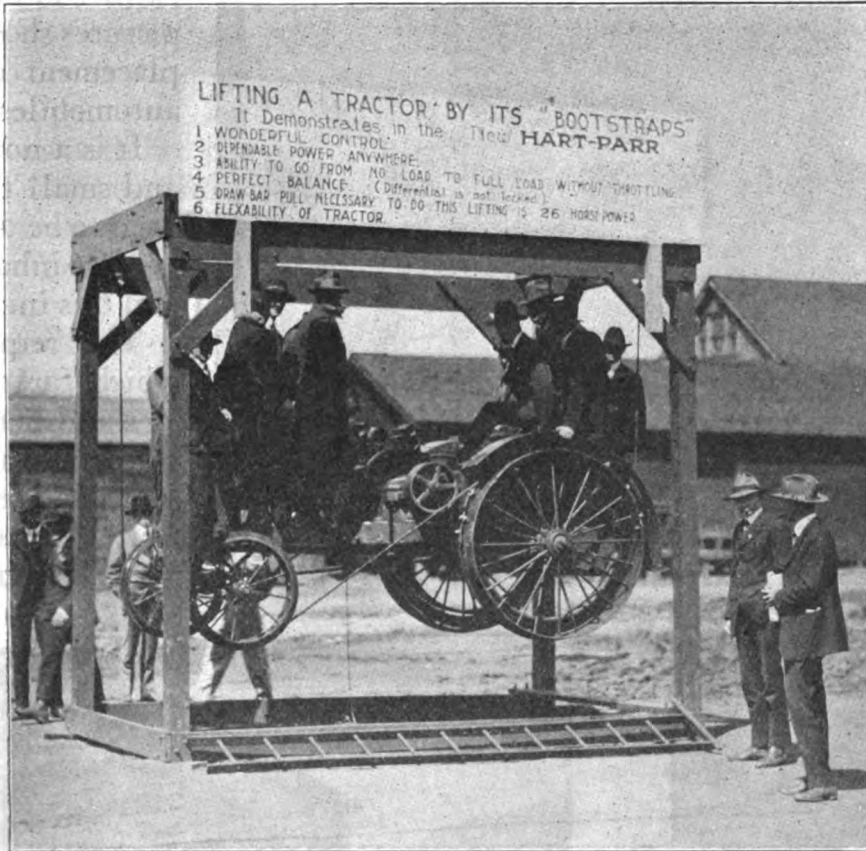

LIFTING A TRACTOR BY ITS "BOOTSTRAPS"
 It Demonstrates in the New HART-PARR
 1. WONDERFUL CONTROL
 2. DEPENDABLE POWER ANYWHERE
 3. ABILITY TO GO FROM NO LOAD TO FULL LOAD WITHOUT THROTTLING
 4. PERFECT BALANCE (Differential is not locked)
 5. DRAW BAR PULL NECESSARY TO DO THIS LIFTING IS 26 HORSE POWERS
 6. FLEXIBILITY OF TRACTOR

LIFTING ITSELF BY ITS BOOT-STRAPS. WIRE CABLES WERE PASSED AROUND THE WHEELS OF THIS WELL KNOWN TRACTOR AND WHEN THE CLUTCH WAS THROWN IN THE DRIVE WHEELS LIFTED THE TRACTOR AND ITS BURDEN INTO THE AIR. THIS DEMONSTRATION WAS STAGED TO SHOW THE WONDERFUL CONTROL AND FLEXIBILITY OF OPERATION OF

THE PRICE

The world knows but little of failures, and cares less. The world only watches the successes.

Stop worrying over things that can't be helped, and go and do things that can be done.

Few people care a continental for your failure. Few, if any, will help.

You may sit and magnify your mistakes, mourn and go mad over your blunders, but men will only smile that cynical smile and say of you: "He's no good."

Self-pity, sympathy - soliciting, wish and wailing, will only let you down lower.

Brace up. Brush up. Think up. And you will get up. Think down. Look down. Act down. And you will stay down.

Paint your face with a smile. Advertise that you are a success. Then think and work for it.

Whatever you think you are is the price they will pay.—The Silent Partner.

Horsepower Chart of Automobile Engines According to the formula of the Society of Automotive Engineers.

| Cyl. Bore. Inches | 1 Cylinder. | 2 Cylinder. | 4 Cylinder. | 6 Cylinder. | 8 Cylinder. | 12 Cylinder. |
|-------------------|-------------|-------------|-------------|-------------|-------------|--------------|
| 2 1/2 | 2.5 | 5.0 | 10.0 | 15.0 | 20.0 | 30.0 |
| 3 | 2.8 | 5.5 | 11.0 | 16.5 | 22.0 | 33.0 |
| 3 1/2 | 3.0 | 6.0 | 12.1 | 18.1 | 24.2 | 36.2 |
| 4 | 3.3 | 6.6 | 13.2 | 19.8 | 26.4 | 39.6 |
| 4 1/2 | 3.6 | 7.2 | 14.4 | 21.6 | 28.8 | 43.2 |
| 5 | 3.9 | 7.8 | 15.6 | 23.4 | 31.2 | 46.8 |
| 5 1/2 | 4.2 | 8.4 | 16.8 | 25.2 | 33.6 | 50.4 |
| 6 | 4.6 | 9.1 | 18.2 | 27.3 | 36.4 | 54.6 |
| 6 1/2 | 4.9 | 9.8 | 19.6 | 29.4 | 39.2 | 58.8 |
| 7 | 5.3 | 10.5 | 21.0 | 31.5 | 42.0 | 63.0 |
| 7 1/2 | 5.6 | 11.2 | 22.5 | 33.7 | 45.0 | 67.4 |
| 8 | 6.0 | 12.0 | 24.0 | 36.0 | 48.0 | 72.0 |
| 8 1/2 | 6.4 | 12.8 | 25.6 | 38.4 | 51.2 | 76.8 |
| 9 | 6.8 | 13.6 | 27.2 | 40.8 | 54.4 | 81.6 |
| 9 1/2 | 7.2 | 14.4 | 28.8 | 43.2 | 57.6 | 86.4 |
| 10 | 7.7 | 15.3 | 30.6 | 45.9 | 61.2 | 91.8 |
| 10 1/2 | 8.1 | 16.2 | 32.4 | 48.6 | 64.8 | 97.2 |
| 11 | 8.6 | 17.1 | 34.2 | 51.4 | 68.4 | 102.6 |
| 11 1/2 | 9.0 | 18.0 | 36.1 | 54.2 | 72.0 | 108.0 |
| 12 | 9.5 | 19.0 | 38.0 | 57.0 | 75.6 | 113.4 |
| 12 1/2 | 10.0 | 20.0 | 40.0 | 60.0 | 80.0 | 120.0 |
| 13 | 10.5 | 21.0 | 42.0 | 63.0 | 84.0 | 126.0 |
| 13 1/2 | 11.0 | 22.0 | 44.1 | 66.1 | 88.0 | 132.0 |
| 14 | 11.6 | 23.1 | 46.2 | 69.3 | 92.0 | 138.0 |
| 14 1/2 | 12.1 | 24.2 | 48.4 | 72.6 | 96.0 | 144.0 |
| 15 | 12.7 | 25.3 | 50.6 | 75.9 | 100.0 | 150.0 |
| 15 1/2 | 13.2 | 26.4 | 52.9 | 79.3 | 104.0 | 156.0 |
| 16 | 13.8 | 27.6 | 55.2 | 82.8 | 108.0 | 162.0 |
| 16 1/2 | 14.4 | 28.8 | 57.6 | 86.4 | 112.0 | 168.0 |

Benton's Recipes

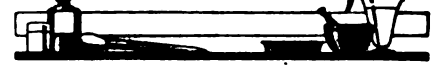

Coloring Metal Work—Cleaning Metal for Coloring.—Metal surfaces to be colored chemically must first be thoroughly cleaned. To remove grease from small parts, dip in benzine, ether, or some other solvent. Boil large pieces in a solution of one part of caustic soda and ten parts of water. For zinc, tin, or Britannia metal do not use caustic soda, but a bath composed of one part carbonate of soda or potash and ten parts of water. After boiling, wash in clean water; do not touch clean surfaces with the fingers, but handle the objects by the use of tongs or wires.

Preservation of Color.—After a part has been given the desired color, it is usually washed in clean water and then dried in clean sawdust. The colored surfaces of alloys are commonly protected and preserved by coating with a colorless lacquer, such as japan lacquer. Small parts are coated by dipping, and large ones by rubbing the lacquer on. The lacquer is hard after drying, and insoluble in most fluids; hence it can be washed without injury.

To Produce a Rich Gold Color.—Brass can be given a rich gold color by boiling it in a solution composed of two parts by weight of saltpetre, one part of common salt, one part alum, twenty-four parts water, and one part hydrochloric acid. After applying this mixture the work is heated over a hotplate until it becomes black, after which it is washed with water, rubbed with vinegar, and again washed and dried.

Blue and Violet Shades.—To give brass a blue color, dissolve 1 oz. of antimony chloride in 20 ozs. of water, and add 3 ozs. hydrochloric acid; then warm the work and immerse it in this solution until the desired blue is obtained. After that, wash in clean water and dry in sawdust.

A beautiful violet color can be produced on polished brass with a mixture of 4 ozs. sodium hyposulphite dissolved in another quart of water, and the two are well stirred together. By heating this to 175 deg. F., and immersing the work the correct length of time, a beautiful violet color is obtained. The work first turns a golden yellow, and then turns to violet. If left a longer time, the violet will turn to blue, and then green. Thus this same preparation can be used for all of these colors by correctly limiting the time that the work is immersed.

Black Varnish for Iron.—A good black varnish for cast iron and forgings can be made of 1/4 pound lamp black; 1/2 pound resin; 1 pound asphaltum; 1 quart turpentine spirits; and a small quantity linseed oil. The lampblack is first rubbed up with the linseed oil, no more oil being used than necessary for this purpose. The other ingredients are then mixed with it thoroughly.

A Simple Welding Flux.—The foreman of a large blacksmith shop gave me the following, which may be of use to our readers. We were speaking of the slag that is formed in the furnace, daily, when he said that he used it altogether as a flux for welding cast steel frames and other broken parts that occur in the repair of locomotives, and other railroad work. All that is required is to pulverize it with a hammer when it is ready for use. It is applied as any other flux would be.

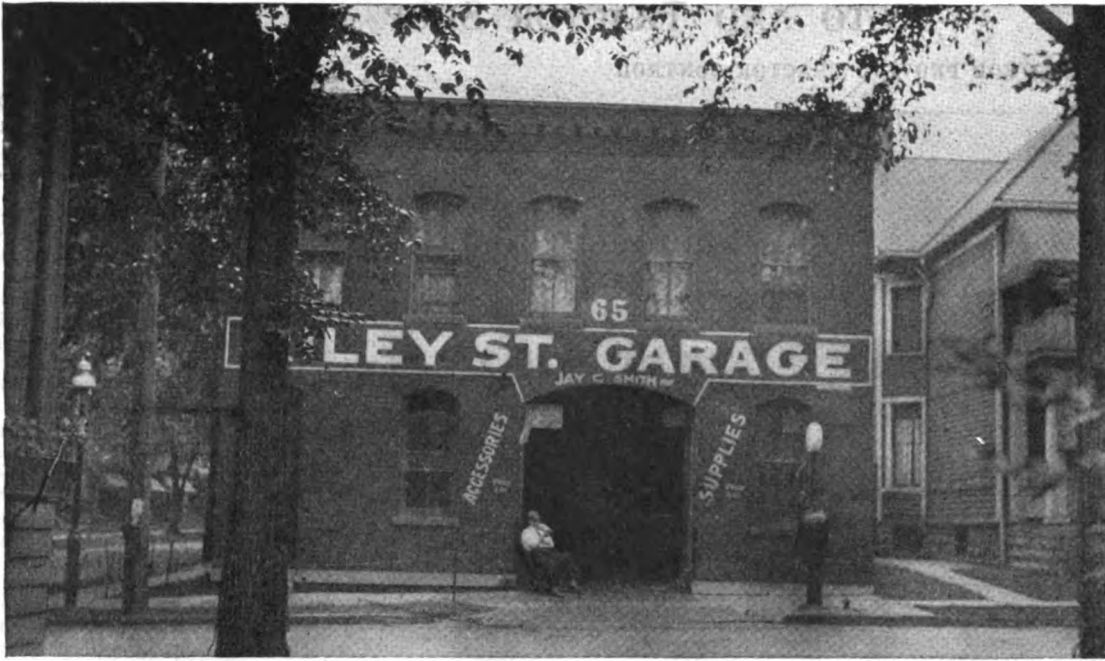

ONCE A FLOURISHING PUBLIC LIVERY STABLE—NOW LOOK AT IT

As we have frequently seen, the immediate prospect of the horse is extinct in our day. The pictures shown on the preceding pages illustrate the displacement of our old-fashioned automobiles.

It is a notable fact that the horse and small that the horse used to be as much of an "oldest inhabitant" and this includes the present.

The requirement of the automobile which far outnumbered the horse and hence it follows that a greater number of repair shops and service stations were of blacksmith shops. The number is growing daily.



JOHN WILDEY'S LATE BLACKSMITH AND WAGON REPAIR SHOP



MR. YOUNG IS HUNTING A LARGER STABLE—FOR HIS AUTOMOBILE REPAIR BUSINESS



GEORGE PORTER DOESN'T OWN A HORSE ANY MORE—THIS IS HIS STABLE TODAY



AN OLD DWELLING HOUSE CONVERTED FOR GARAGE PURPOSES

stated, there is no im-
 he horse will become
 generation at least, the
 ge show the rapid dis-
 e friend in favor of

at in towns both large
 ic livery stable which
 own institution as the
 ractically non-existent
 e stables as well.

f automobile owners,
 orse owners, must be
 s that there are today
 omobile garages, repair
 s, etc., than there ever
 s and stables and the

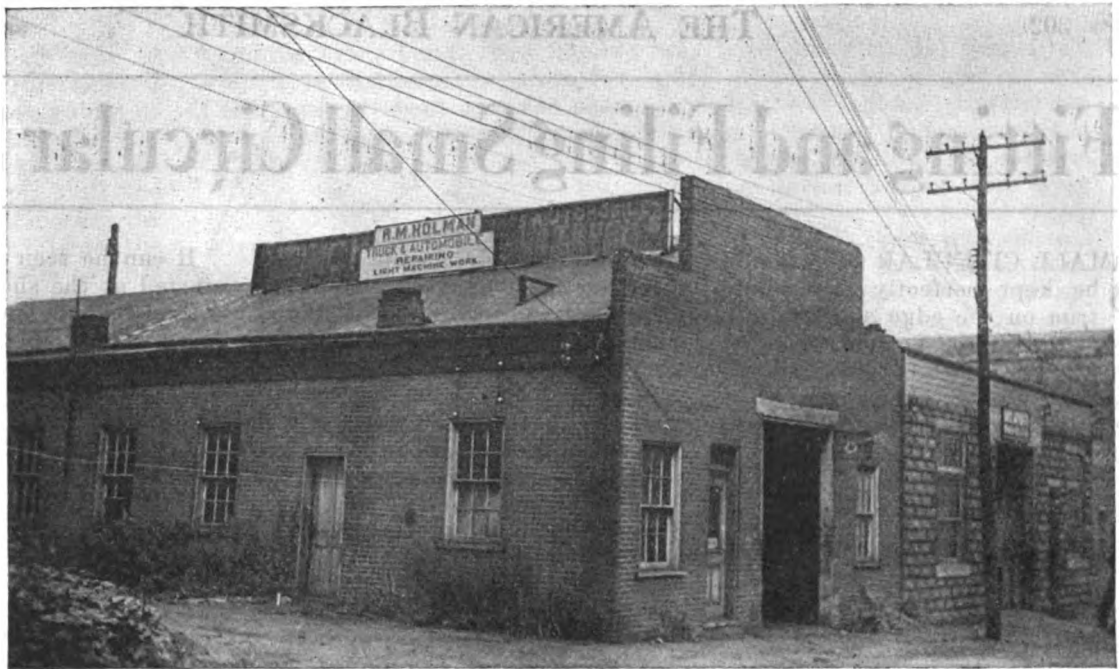

THIS SUBSTANTIAL BUILDING WAS AT ONE TIME A WAGON AND BUGGY FACTORY THAT HAS MOVED INTO SMALLER QUARTERS



AN ELABORATE STABLE OF THE PRE-AUTOMOBILE PERIOD. NATURALLY IT WAS ONLY PERSONS OF MUCH WEALTH WHO BUILT STABLES OF THIS CHARACTER. THIS ONE WAS A WONDER IN ITS DAY

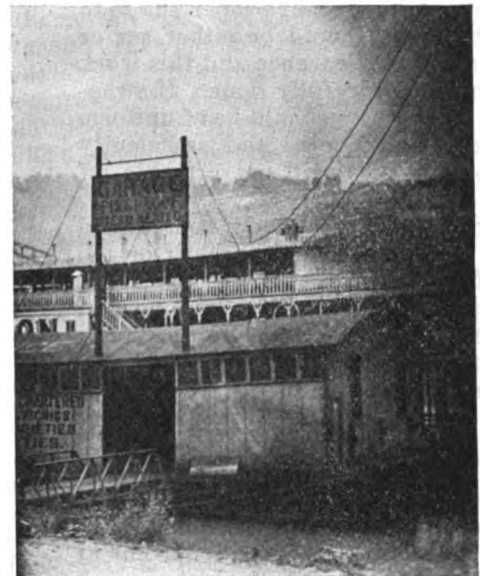

AND AT PITTSBURGH THEY EVEN BUILD GARAGES ON THE RIVER

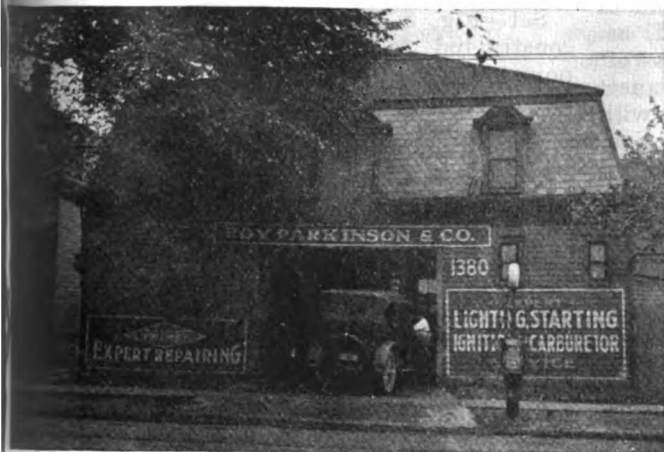

YOU DON'T NEED TO LOOK TWICE TO SEE WHAT THIS BUILDING WAS ORIGINALLY BUILT FOR



WHAT HAS BECOME OF THE HORSESHOE PITCHERS THAT USED TO LOAF AROUND JOHNNY LIEBER'S BLACKSMITH SHOP?

Fitting and Filing Small Circular Saws*

SMALL CIRCULAR saws should be kept perfectly round and true on the edge and the gullets round at the bottom, of equal depth and width. They should never be filed to sharp corners at the bottom of the teeth for this will cause them to crack at this point.

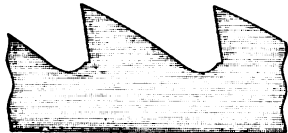

FIG. 1

The best results can only be obtained by keeping the points of the teeth sharp and in proper shape to cut. They should be either set or swaged for clearance and this work should be carefully done. If swaged, the corners should be of uniform width and depth, and sufficiently stout so they will not crumble off in the cut.

Saws are frequently complained of as being either too hard or too soft, when in reality the trouble is entirely due to the manner in which they are filed. For instance, if the teeth are lacking in hook and are extremely stout at the points, as shown in Fig. 1, they will cut hard even when sharp.

When they become slightly dull, which they will in a very short time, on account of the blunt shape of the points, they will not cut at all and are very liable to crack when in this condition.

It is recommended, therefore, that the teeth be kept in proper shape as shown in Fig. 2, and the results obtained, both in quality and quantity of work done will pay well for the time and labor expended in keeping them in proper condition.

An emery wheel or round file is



FIG. 2

indispensable to the proper care of these saws, for it is impossible to maintain the desired shape with the use of a common flat file only.

Machines are now made to keep these teeth in perfect shape but these are naturally only found where there is a large number of saws to be cared for.

In order to maintain the original pitch and back line of the tooth, it is necessary that about the same amount of filing be done on the back as on the front of the tooth. For if there is more filing done on the face of the tooth than on the back, the original shape is soon destroyed and it is almost impossible to restore it to the proper shape without re-toothing the saw.

Fig. 3 will perhaps illustrate the idea better than anything that might be said on the subject. This illustration represents a tooth of a saw where all the filing is done on the face. The bad results from this method of filing can readily be seen. The body of the tooth is now so slim that it will not support the point in doing its work, but will

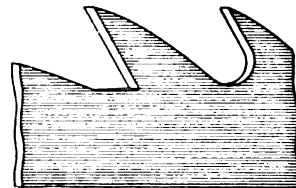

FIG. 3

chatter and vibrate in the cut and be liable to eventually break at this weak point.

Figure 2, previously referred to, represents a tooth very well adapted to miscellaneous work, but if very hard or kiln dried hardwood is to be sawed, a narrower gullet and a stouter tooth is recommended, as shown in Fig. 4. For this class of work the set or swage for clearance should be the least amount that will clear the plate and prevent friction and heating. The smoothness of the work done and the light and easy running of the saw depend largely on the teeth being properly set for the special work required of the saw.

Cracking at Rim—Among the various causes of cracking at the rim is filing sharp corners at the bottom of the teeth. Fig. 5 represents a section of a 14" saw filed in this manner which cracked and was sent to the manufacturer for repairs.

It can be seen that the fracture started at the sharp notch for the reason that the entire strain is centered at this point instead of being distributed throughout a larger circle. The sharp notch also pre-

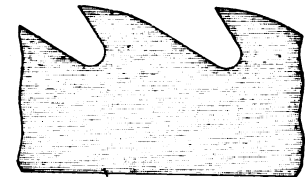

FIG. 4

vents the free circulation of the sawdust.

Of these illustrations, Fig. 6 represents the proper and Fig. 7 the improper manner of fitting saws full swage.

The teeth of saws are frequently split at the points by attempting to swage them when in the condition shown in Fig. 7. The teeth should always be kept in about the shape shown in Fig. 6 and much trouble will be avoided in swaging and fewer split or cracked saws.

No matter whether rip saws be fitted with swage or spring set, they should be filed straight across in front and back of teeth.

It is a mistake to think that rip saws will do better work if beveled than if dressed square across. A beveled tooth has a tendency to split the fiber instead of cutting it off squarely across. The bevel also produces a lateral motion which causes the teeth to vibrate and chatter in the cut. Many saws are cracked from this cause.

Set—Fig. 8 represents a finely constructed tool for setting the points of teeth in small rip and cut-off saws. This is considered one of

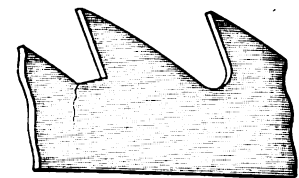

FIG. 5

the best and simplest tools for the purpose on the market. This tool is a combination tool, having a gauge attachment for the purpose of regulating the amount of set. It can be seen that this set is provided

with setting slots which are so graduated as to give the desired depth to the set in each gauge of teeth they are intended to set.

When placing the set on the tooth, permit it to drop until the point of the tooth touches the bottom of the slot and bend the tooth over until the gauge touches the side of the plate. The set will then be perfectly accurate and uniform.

Fitting Small Circular Cut-Off Saws.—In fitting small circular cut-off saws, as in the fitting of small rip saws, it is essential in all cases that they be kept perfectly round and true on the edge. The teeth

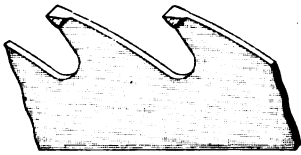

FIG. 6

should be of uniform width and shape and the gullets of equal depth and width. Every tool should have the proper amount of bevel and this bevel should be alike on both sides of the tooth when a "v" tooth is used.

It can be seen in Fig. 9 that the point of the tooth only is beveled. The point of the tooth being the only portion of the tooth that cuts, the remainder is left square across to carry out the sawdust.

Fig. 10 is a representation of Fig. 9 improperly filed to a sharp corner at the bottom of the tooth.

If the same amount of time and labor were used in dressing out the gullets with an emery wheel or filing them down with a round file that is used in filing the long bevel and sharp notch at the bottom of the tooth, as shown in Fig. 10, much trouble would be avoided from the cracking and breaking of saws.

In all saws where the teeth are sufficiently far apart to admit it the gullets should be kept round.

Set—The amount of set in these saws should be the least that will clear the plate sufficiently to prevent friction. The setting of the teeth is an important matter, and this work should be carefully done. The set should never extend too far into the body of the tooth, neither should the tooth be set too close to the point. Where an attempt is made to set the teeth too far into the body, the plate is often cramped, and saws are often cracked in this way.

On the other hand, they should never be set too near the points, for if the teeth are bent over too near the points they will be "needle-

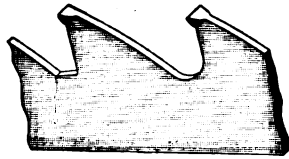

FIG. 7

pointed" when beveled. They will cut rough when in this condition and the points will be liable to bend back or crumble off in the cut.

Fine Tooth Cut-Off Saws—These saws, if used where fine work is desired, require no hook or pitch to the work (see Fig. 9).

But where more rapid work is desired, a pitch to the center tooth, as shown in Fig. 12 will cut more rapidly, but the work will not be quite so smoothly done.

Fig. 11 shows the proper shape of the teeth, and the manner of

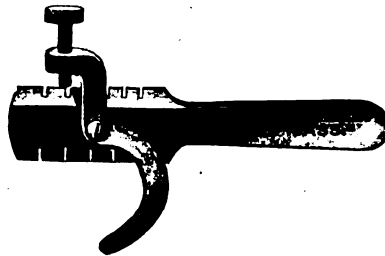

FIG. 8

filing Cut-Off and Mitre saws. This filing is done with a taper file, and the teeth are beveled alike on both sides.

*Copyrighted By Simonds Mfg. Co.

FUTURE TRACTORS WITH ELECTRIC STARTERS

F. H. Sweet

When electric starting systems were first suggested for tractor motors four or five years ago most engineers agreed they would be very convenient if they would work, but none of them believed they could be made to withstand tractor vibration. There really were a good many experimental installations that had to be discarded on that account.

The vibration of the tractor shook the clamping nuts loose on the battery terminals, displaced the spacing bars between the battery plates, broke down the supports for the plates and even shook the paste out of the grids. Spring suspension under the battery boxes

was tried, but that did very little good. The tractor engineers concluded it was no use experimenting any further and passed the word along the line that electric starting devices for tractors were failures.

At the time these experiments were made by the tractor companies, the market for such apparatus was limited and the storage-battery manufacturers thought it was not worth giving much attention. They were devoting their efforts to trucks and automobiles

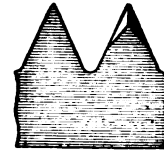

FIG. 9

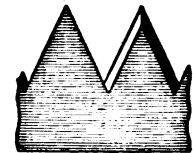

FIG. 10

and other installations where business was more plentiful. Then came the war, and there was a demand for motor trucks for the army, with starting systems of sturdier make than had been used at that time in commercial work. The army engineers made up their specifications and invited the various manufacturers to submit samples for inspection and tests. The batteries all looked well and gave a good account of themselves on stationary tests, but that was not sufficient; they had to be able to withstand the hard service of the army supply trains over bad roads, with bad care and hard driving.

In order to make sure they would be able to perform reliably under these conditions the army engineers devised a testing machine that would lift a battery three-eighths of an inch and let it fall on a hard,

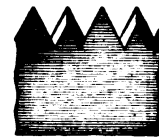

FIG. 11



FIG. 12

unyielding surface 480 times a minute, or 28,800 times in an hour. In thirty-six hours a battery received more than a million such shocks. It was a very severe test, and the first batteries that were submitted went to pieces considerably under the half million point. In consequence of this poor showing none of the batteries were accepted, and the manufacturer's all went back

home to improve their products.

A few weeks later they returned, and, if I have been correctly informed, all of them went through the tests without serious trouble. All the batteries were able to stand two million drops on the testing machine without showing any signs of distress. The manufacturers had provided rubber supports for the battery boxes, had used thicker grids, more substantial insulators and better supports and distance pieces for the plates. They used better lock nuts for the terminals and turned out much better batteries. The improvement wrought in such a brief time surprised most engineers and was the subject of no little discussion among the profession.

In discussing the matter with an electrical engineer who has had many years of experience, he said: "The battery makers knew all along how to make better batteries, but for years they had been trying to see how cheaply they could make them. Competition was sharp, and in order to get business they shaved down the thickness of the plates, used the minimum of material and produced a cell that would give fair service under favorable conditions.

"At the same time they were making batteries for such service as electric lights for railway coaches, where the vibration is tremendous and the service much harder than on trucks. When they had to turn out a good product and were not hampered too closely by price, they had no trouble in fulfilling all conditions. It was not ignorance on the part of the battery people that was responsible for frail batteries, but business competition."

Shortly after the government tests were made, one of the engineers read a paper in which he predicted that tractors would soon come to the use of starting and lighting systems. The other engineers present were skeptical and expressed lack of faith in storage batteries, even after having been shown the results of the tests. They believed tractor service is harder on a battery than any other kind.

Engineers who are acquainted with the various kinds of battery service, however, tell me that tractor service is not very difficult. It is not so severe, they say, as trucks or automobiles, and does not compare with railway-car installations. The greatest difficulties

IF YOU STEAL A CAR DON'T TRY TO SELL IT IN PENNSYLVANIA

A bill which will effectively regulate the sale and transfer of second hand automobiles has been signed by the Governor of Pennsylvania. The "second-hand car" bill requires complete description with bills of sale, statements as to ownership and changes made in the car, all to be sworn to, one copy to be filed with the state highway commissioner and one with the chief of police or clerk of the court of quarter sessions. Operation is forbidden until such statement is filed when a car is sold. All dealers in second hand cars must take out a state license at an annual fee of \$100, and be vouched for by two persons.

Various other provisions for tracing stolen cars are made. Every garage keeper must keep records of all cars left with him. No one may have a car from which the identifying marks have been removed. Notices of discovery of tampering with such marks are required. The penalties range from \$100 to \$1,000 and imprisonment at the discretion of the court.

arise from lack of care during the winter season when the tractor is laid up for several months.

If the battery is not kept fully charged it is likely to freeze. When a battery is full charged it will stand any winter temperatures to be found in this country, but if permitted to run down it may freeze at temperatures even above zero. The proper thing to do is to remove the battery during the winter season and store it in a garage where it will be properly taken care of.

Altogether about 10,000 starting

systems have been put on tractors, and it was my privilege recently to examine the service sheets. Those for March were particularly interesting because that is the month when the tractors were taken out of winter quarters and put to work. Out of the total number of installations less than one-fifth of one per cent reported trouble, and in all cases this was of a very insignificant nature, such as loose or corroded terminals, which are easily repaired. Rust caused more trouble than either frost or vibration, and even that was negligible. If every other part of the tractor made an equally good showing, tractors would be more popular than they are.

It is always rash to prophesy what will take place, but when one considers how rapidly starting and lighting systems have been adopted by the motor-car companies, it seems reasonable to expect that tractors will follow the same line of development. No one likes to crank a gas engine. It is not only hard work, but dangerous as well. Many broken arms have resulted from the kick-back of motors, and low-grade fuel does not make starting any easier. Most people would be glad to be rid of such trouble, and I have little doubt that before many years pass the public will demand electric starters on tractors.

This idea seems to be shared by a number of the more progressive motor manufacturers, because they are sending out their new engines with brackets to carry the generator and starting motor, and with gear teeth cut on the fly wheels to mesh with the armature shaft of the electric starter. They are not as yet adding electric equipment as a part of their standard product, but if the manufacturers of the tractor wish to use such a system, the motors will not need to be changed.

SPECIAL BEARING PULLER

The sketch shows how to make a puller for cone bearings. It was especially designed for doing the work by a local shop man. The wedge shape feet force themselves in between the back of the bearing and the shoulder and then

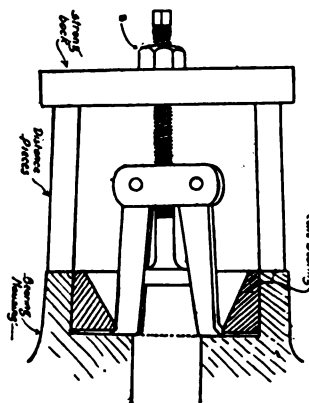

SPECIAL BEARING PULLER

grip the bearing for pulling. To adjust the feet the screw is turned by putting the wrench on the squared end and turning until the feet are forced into place, then the bearing is pulled by setting up on the nut B. The legs and crosshead are of forged steel while the distance pieces and strong-back are of wrought steel.

It occasionally happens that a check is not presented for payment for some time after it is received, the delay being anywhere from a few days to months or years. Usually, of course, this raises no question as to its payment, and the check is honored when it is presented. But sometimes the delay occasions a loss, as in the following cases:

(1) Where the drawer (maker or signer) of the check removes his money from the bank. (2) Where the drawer of the check becomes bankrupt. (3) Where the bank on which the check is drawn fails before the check is paid.

The Negotiable Instruments Law, which has been enacted in a number of states, and which substantially follows the Law Merchant relating to bills, notes and checks provides that "A check must be presented of payment within a reasonable time after its issue, or the drawer will be discharged from liability thereon to the extent of the loss caused by the delay."

From this it will be seen that the drawer of the check is liable for the amount, even where, as in the first case given, he has withdrawn his money from the bank. He is supposed to know what checks he has drawn and to have money in the bank to pay them. If he withdraws his money before the check is paid he is still liable to the holder for the amount, no matter how long it may be held before being presented for payment. If he can show that the delay caused him a loss, he may set up this loss as a counter-claim.

If the drawer of the check goes into bankruptcy, the holder of his check must disregard the check and present his claim to the receiver along with other creditors. The bank would not pay a check signed by a bankrupt after the receiver takes charge of his affairs.

It is in cases where the bank fails that the question most often gets into the courts. Here the law is that the holder of a check must bear the loss caused by his delay. He is not liable for the failure of the bank, but he is liable for his negligence in getting the check to the bank "within a reasonable time." After the bank has failed no checks are paid, the money on deposit being paid out to the depositors as it is received by the Receiver appointed by the court. The

Cashing in Your Checks

R. H. BUTZ

Mr. Butz tells in this article a number of things about the payment of checks that perhaps the most of us never heard about but good things to know.

question in the case of checks is as to who shall bear the loss occasioned by the failure.

To illustrate this point we will assume that Q has money on deposit, and gives a check to A on March 1st, to B on March 2nd, and to C on March 3rd; that all these checks are brought to the bank on the morning of March 4th by A, B and C, only to find that the bank will not open that morning. Can they immediately demand their money from Q, or will they have to wait until dividends are paid by the bank, and then receive from Q the percentage of their checks that he receives on his total deposit?

The question turns upon the definition of a "reasonable time." The courts have held that the holder of a check has until the next business day after he receives it to start a check toward the bank on which it is drawn. This means that C, who received his check on March 3rd, is within the "reasonable time" when he presents his check on March 4th. He can demand the money from Q. C must not be asked to bear the loss occasioned by the failure of the bank.

If B lives in the town where the bank is located, he has not presented his check "within a reasonable time" (supposing March 2nd and 3rd to have been days on which the bank was open); but if he lives in another town, it is sufficient if he has started it toward the bank on the day he received it, or the next business day. The same is true of A.

If B and A have to bear the loss, they are in the same position they would have been if they had had money on deposit in the bank. That is, they must wait until the dividends are paid to Q, who is bound to turn the money received over to them. If their checks are for \$500 each, and the bank pays dividends amounting to 60%, each would receive \$300.

It is to be noted that Q is in exactly the same position as regards the bank, whether these checks are cashed or not. If they are cashed, his debts to A and B are canceled, and his deposit in the

bank is reduced by \$1,000. If they are not debts to A and B with the percentage of the cashed, he cancels his \$1,000 received from the bank.

But suppose that C, who received his check on March 3rd, had had it certified that day. He would then have been in the position of A and B. He would have to bear the loss. The reason is that he might have demanded payment of the check, instead of certification; and by accepting certification he made the bank, and not Q, his debtor.

The courts seem to take the view that a man cannot be expected to rush to the bank the same day he receives a check to secure the money; but when he is at the bank, it is no more trouble to get the money than to have the check certified. If he chooses to have it certified, he accepts the promise of the bank to pay instead of the cash. If the bank cannot pay, he is the loser.

Or suppose that A, who received the check on March 1st, had indorsed it to D, and that it was not received at the bank until March 4th, after the bank had closed. If the delay was caused by A, it will probably come under the provision of the law which provides that "where an instrument payable on demand is negotiated an unreasonable length of time after its issue, the holder is not deemed a holder in due course." And if the delay is caused by D, he must bear the loss. We may therefore say that if there are indorsers, they are discharged from liability in case of loss occasioned by delay. They are also discharged if the holder secures the certification of the check.

If the holder of a check does not live in the town where the bank is located, he must forward it by the most direct route. It has been held that forwarding it through several banks, even though this may be the usual course of business, is not sufficient. Thus in *Gregg v. Bean*, where a check was forwarded in the "usual course of business" through several correspondent banks, and so arrived after the bank on which it was drawn had failed, it was held not to be "within a reasonable time," in view of the fact that if it had been mailed by the holder, or by his bank, direct to the bank on which it was drawn it would have been paid.

Queries-Answers-Notes



THIS department is the meeting place where you are free to ask for information, answer questions, discuss shop matters and business conditions and any other notes you feel would be of interest to a fellow mechanic. Make use of this Department as often as desired.

Wants Prices—We would be glad to see through your columns the general current prices for general buggy and wagon repair work, woodwork and blacksmithing prevailing in the neighborhood of Cleveland and Ashtabula.

M. S. McFarland & Sons, Ohio.

This invitation is as broad as it is long and we would be glad to publish prevailing prices not only in the localities mentioned but others as well.

Editor.

Drilling Chilled Mould-Boards—I saw in the July number that H. P. Jensen, of Oregon, was having trouble in drilling chilled mould-boards. I will say that they can be drilled for I am doing it right



FRANK KING HAS KIND O' GOTTEN AWAY FROM HORSE-SHOEING BUT HE ADMITS THAT HE STILL IS CALLED UPON TO DO AN OCCASIONAL SHOEING JOB

along and sometimes have plated as many as three or four in a week. It usually requires about half a day to drill eight holes but if I have good luck it will take a little less time. Some of the castings are harder than others.

First I make a bit out of cast steel and harden it with yellow prussiate or potash. The drill is heated just red hot and the prussiate is applied to the end of the bit and place it back into the fire and heat to almost a white heat and plunge into water. Borax can be used in the same way. I use both of them and have had good results. In using the drill, run the drill by hand and do not feed the drill too fast.

I get \$3.50 for plating mould-boards and you earn it too.

E. S. Sheets, Penna.

Thanks, Mr. Wells—"Also send me one of Dyke's Automobile Encyclopedias by parcels post. I am running my shop into the garage business as fast as I possibly can and I don't know of any better plan than to read good books and papers like the American Blacksmith, Auto & Tractor Shop. I hope you will continue to give more auto information in each copy."

J. H. Wells, Texas.

Grinding Wheels—What kind of emery wheel is the best for general use and why are some kinds "dull"?

J. Parmelee, Australia.

A wheel that is too soft is always sharp but wears down rapidly. On the contrary, a hard wheel is nearly always dull. A wheel that loses its shape and wears down quickly is nearly always too soft. It is advisable to use carborundum wheels for grinding cast iron, brass or aluminum. For materials like steel an aloxite wheel would be more suitable. The speed of the wheel has much to do with the efficiency of the wheel. The faster the wheel runs the more it assumes the characteristics of a hard wheel. Many wheels are condemned for being too soft near the center for the reason that as the outer surface is worn down the wheel is reduced in diameter and if operated at the same speed, the rim speed is considerably reduced. The slower speed makes the wheel appear too soft. Worn wheels should be speeded up to give uniform results.

Spring Steel—Can you give me the address of a firm that I can obtain high grade spring steel for automobile leaf springs?

J. Hogan, Missouri.

The Jenkins Vulcan Spring Co., Richmond, Ind., can meet your requirements in any size promptly.

Horn Operated From Magneto—Do you think that the magneto of a 1915 Ford is powerful enough to operate a vibrating horn that I am now operating with dry-cells.

C. Kimberley, Penna.

The magneto should operate the horn successfully. From the magneto terminal on the coil box run a wire to the horn; from the horn run a wire to the push button and then run a wire from the push button to the frame of the car.

Slipping Ford Clutch—A 1912 Ford does not seem to have much power on hills but operates very satisfactorily on level stretches—why is this?

L. Sebring, Arkansas.

The clutch is probably slipping. Adjust the screws in the clutch fingers, turning each equally a half turn or more. If investigation should show the clutch to be badly worn it would be best to replace the old clutch discs with new ones.

To Oxidize Copper—Can you give me a receipt for oxidizing copper? I am making an ornamental lamp shade and desire to finish it in this manner.

A. N. Somerscales, Canada.

Dip the copper article into a solution composed of the following:—nitrate of iron 2 ounces, hyposulphite of soda 2 ounces and water 1 pint. When the desired shade of oxidation has been obtained, wash dry and lacquer.

Source of Power—A friend and I have had a discussion on what gives the power to automobile engines and we would like to know which of the three, gasoline, compression or the explosions give the power.

R. C. Williams, Okla.

To make the matter as clear as possible without giving explanations of a technical character, power is obtained from the expanding gases or explosions of gasoline. The gasoline itself has no power to act. It is said to have potential energy which is liberated only after the ignition spark causes an explosion; rapid expansion of gases. Thus the power derived from the exploding charge is the answer.

Carbon Remover—Which of the carbon removers that are on the market would you recommend?

J. S. Steele, Wyoming.

We are not attracted to compounds as carbon removers. The best method of carbon removal is to either burn it out by the oxygen process or scrape it out.

Notes on Chimney Flues—The value of the flue depends on area and velocity. Velocity alone is no proof of good draft—there must be also sufficient area to carry the gases.

The chimney top should run above the highest part of the roof. The chimney should be so located with reference to any higher buildings nearby that wind currents will not form eddies and force the air downward in the shaft. A shifting cowl, which will always turn the outlet away from the adverse currents, will promote better draft.

The flue should run as nearly straight as possible from the base to top outlet. The outlet must not be capped so that its area is less than the area of the flue. The flue should have no other openings into it but the smoke pipe. Sharp bends and

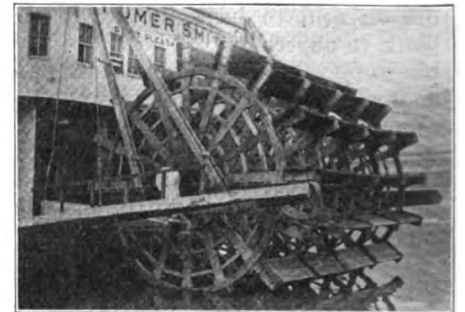

THE BUSINESS END OF AN OHIO RIVER STERN - WHEELER. RIVER BLACKSMITHS ARE FREQUENTLY CALLED UPON TO BUILD AND REPAIR SUCH WHEELS WHICH ARE OF OAK BOLTED TOGETHER. THE PADDLE BOARDS ARE HELD BY "U" BOLTS

offsets in the flue will often reduce the area and choke the draft. The flue must be free of any feature which prevents full area for the passage of smoke, etc.

If the flue is made of tile, the joints must be well cemented, or all space between the tile and brickwork filled in tightly. There must be no open crevices where the sections meet—otherwise the draft is checked.

If the flue is made of brick, the stack should have outside walls at least eight inches thick to insure safety. The inside joints should be well struck; each course

should be well bedded and free from surplus mortar at the joints.

If there is a soot-pocket in the flue below the smoke pipe opening, the clean-out door should always be tightly closed. If this soot-pocket has other openings in it— from fire-places or other connections— these openings check the draft.

The smoke pipe should not extend into the flue beyond the inside surface of the flue, otherwise the end of the pipe cuts down the area of the flue.

The joints, where the smoke pipe enters the chimney should be made tight with boiler putty or other cementing material.

Cleaning Water Gauge Glass—I have a steam heating system in my shop and would like to know if I can clean out the water gauge glass without removing it from the boiler.

J. Hambrey, Illinois.

Draw a cupful of hot water from the boiler, into which pour at least a tablespoonful of raw muriatic or other acid.

2—Close both water gauge valves.

3—Open the top water gauge valve and also pet cock at bottom, and blow water out of the glass. Then immediately close the top valve and submerge the end of the pet cock in the hot water and acid solution referred to. A vacuum is at once created in the gauge glass which causes the solution in the cup to rush in.

4—Keep the pet cock immersed and operate the top valve, slightly opening and closing, alternately expelling and drawing in the solution until all grease, oil or other matter adhering to the inside of the glass is cut out. Then close pet cock and open both water gauge valves.

It is necessary to have one pound pressure of steam or more on the boiler before commencing this operation, which need not occupy more than ten minutes. The result is a clean glass without the risk of breakage and probable renewal of gaskets, which is frequently the case when removing the glass for cleaning.

Auto Parts, Etc.—Some time ago I saw an article in your paper telling of different men who had started a small garage and began keeping auto supplies. Now, I am working into the automobile business and would like to carry supplies; the principal parts for Ford cars in particular. Can you tell me how I can obtain the agency for these or if not the agency to send for the parts.

Bert J. Miller, New York.

Genuine Ford parts will be furnished to garages and repair shops by your nearest authorized Ford agent at 25% from the price listed in the Ford parts book. Take the matter up with this dealer or communicate with the nearest Ford branch which in your territory is located at 346 Broadway, Albany. Miscellaneous supplies and accessories can doubtless be ob-

tained through the jobber or heavy hardware dealer who has hitherto supplied your requirements as practically all such firms now carry complete lines of motor supplies. You might also ask such firms as Cray Bros., Cleveland, O., Beals, McCarthy & Rogers, Buffalo; H. D. Taylor Co., Buffalo, Campbell Iron Co., St. Louis, Mo., etc., for copies of their motor supply catalogues.

Gasoline Filling Stations—Mr. Siddall, editor of The American Magazine, has referred me to you in regard to getting the necessary information, for starting a gasoline and vulcanizing station.

Would the company, from which I would buy my gasoline, oils, etc., install

of unfair competition in connection with the installation of gasoline pumps and storage tanks. The charge of unfair competition comes from the fact that some of the companies have compelled the purchaser to agree to buy or sell gasoline other than that supplied by the company. The gasoline pumps are furnished by the oil companies on a rental basis, the pump and tank being furnished and installed at the expense of the company, as we understand at a nominal rental of a dollar a year. It is likely that the complaint of unfair competition referred to above might have altered this practice some but where there's a will there's a way and no one knows this old saw better than the oil companies.

See the local representative of the company you intend doing business with and talk the matter over with him. A great deal depends on the amount and quality of the competition in your vicinity. If the Standard has a monopoly on the business some other company would probably welcome the opportunity of an opening. If you buy a gasoline pump yourself the same would cost approximately \$500.

As to the amount of capital required we have no way of knowing. But if you have a building already constructed and ready for use then the amount should not exceed \$500 at the outside and it is entirely possible that by making proper credit arrangements that little or no capital will be required other than what is absolutely necessary for repairs and alterations. Of course if you will have to build an office, a driveway, or repair and alter an old building for your purpose a larger amount of capital would be required.

If space permits it would be advisable to have the cars drive in at one end and out the other with a roof to cover the car while filling in bad weather. Another thing that you should consider by all means is the installation

of an air compressor for filling tires. This is a convenience that is appreciated by motorists and increased sales that are directly traceable to this feature are surprising.

It Always Happens This Way—"I am sorry to inform you that I have had some bad luck. On August 21 I had the misfortune to have my shop burn to the ground with the loss of all its contents and with no insurance. I could not have it insured on account of my blacksmithing being in the same room. I had a building 24x45 feet, two stories and with more tools and machinery than any other shop in the county. My loss is estimated at \$2,500 which is total, except for the trivial sum I can obtain for junk. I hope no brother will have the same luck that has fallen to me."

OXY-ACETYLENE WELDING AND BRAZING
AUTO REPAIRING, TIRES AND ACCESSORIES

E. W. KITTO

Blacksmithing and Garage

Pitcher Phone 54
Scales Mound, Illinois

DEAR SIR:—

We want you to become better acquainted with us - we want to become better acquainted with you - in order to do this we have got to see each other and we know of no better way than to inform you of the various lines we carry.

Namely : Racine and United States Tires, Two of the best and most widely advertised makes, both with a 5,000 mile guarantee. Em-Ar-Co Motor Oil; Standard Gasoline; all kinds of greases (transmission and cup). In addition to the above we carry a full line of accessories together with a complete repair shop.

FREE AIR — it costs you nothing. Take advantage of this.

The thing we want to impress upon you is to get acquainted with us -- it will pay you.

Yours for good service and quality goods.

T. W. Kitto, Garage

F. W. KITTO DOES NOT BELIEVE IN LETTING HIS FRIENDS AND CUSTOMERS OVERLOOK THE FACT THAT HE IS IN THE AUTO REPAIR AND ACCESSORY BUSINESS AND THIS IS A SAMPLE OF THE BUSINESS GETTING CIRCULAR LETTERS HE SENDS OUT AT INTERVALS

the tank and necessary apparatus? If so under what conditions. About how much capital would I need in order to start in this business?

I am leaving it up to your better judgment for full particulars and you may be sure that I will appreciate any information you may be able to give me.

J. Kavanagh, New York.

There are a number of elements entering into the success of a gasoline filling station and possibly the most important is that of a good location. If the site is on a main street or better still at the junction of two thoroughfares on which there is considerable traffic success should be assured.

Recently the Federal Trade Commission has had the oil companies, or some of them, on the carpet to explain charges

INDEX TO VOLUME XVIII



A

| | |
|--|------------------|
| Acceptance of Offer Completes Contract | 232 |
| Accounts, Stock | 151 |
| Accounting, Value of Cost | 282 |
| Acetylene Gas, Manufacture of Compressed | 23 |
| Acid Hardening Bath | 143 |
| Acres Plowed With Tractor in 1 Day | 231 |
| Adjusting Bearings | 81 |
| Adjusting Brakes | 11, 120 |
| Adjusting Carburetors on 20 cars | 16 |
| Adjusting Ford Steering Gear | 24 |
| Adjusting Valve Springs | 167 |
| Adjustable Clamp | 222 |
| Air Drills, Repairing | 135 |
| Alabama, Prices in | 51 |
| Alcohol as Carbon Remover | 208 |
| Alloy, Aluminum | 117 |
| Alloy for Drawing Colors on Steel | 39 |
| Aluminum, Alloy | 117 |
| Aluminum, Solder | 273, 285 |
| Aluminum, Soldering | 285, 295 |
| Aluminum, Welding | 276 |
| Aluminum, Working | 91 |
| Ammeter, Watch the | 39 |
| Andean Horseshoeing | 280 |
| Annealing Methods | 47 |
| Anti-Freeze Solutions | 96, 112 |
| Anti-Leak for Bicycle Tires | 65 |
| Anti-Scale | 13 |
| Answers to Income Tax Problems | 154 |
| Anvils, Refacing | 156 |
| Anvils, Vise | 227 |
| Applying Connecting Rod Bushings | 222 |
| Arbor Press | 119 |
| Arc Welding, Electric | 107, 147, 178 |
| Army Horseshoer, The | 22, 48, 101, 125 |
| Art's Overland Express | 293 |
| Assembling Magneto Gears | 213 |
| Attachment, Bending | 118 |

| | |
|---------------------------------------|--------|
| Auto Bearings, Care and Adjustment .. | 81 |
| Auto Body Polish, Liquid | 186 |
| Auto Body Made of Huge Redwood .. | 201 |
| Auto, The First | 139 |
| Auto Painting | 149 |
| Auto Radiator Cement | 192 |
| Auto Rims, Straightening | 215 |
| Auto, Steam Driven | 172 |
| Auto, Springs, The Steel in | 20, 45 |
| Auto Wheels, Toe in of | 51 |
| Auxiliator, Motor | 144 |
| Average Life of Tractor | 11 |
| Axles, Towing Car with Broken | 153 |

B

| | |
|---|-----------------------|
| B. T. U. | 129 |
| Babbitt, Heating | 165 |
| Bad Roads | 133 |
| Balancing the Overhead | 224 |
| Barrels, Bluing Gun | 221 |
| Bars, weight of Square Steel | 63 |
| Bars, weight of Round Steel | 37 |
| Base, Concrete Engine | 104 |
| Bath, Acid Hardening | 143 |
| Batteries, Storage, Repairing | 8, 15, 41, 49, 74, 99 |
| Batteries, Storage, Sealing Compound .. | 9 |
| Batteries, Storage, Keeping Charged in Winter | 101 |
| Batteries, Storage, Burning Connections | 130 |
| Batteries, Storage, Explosions, | 225 |
| Bearing Puller | 304 |
| Bearings, Auto, Care and Adjustment .. | 81 |
| Bearings, Building up | 117 |
| Bearings, Keeping Cool | 223 |
| Bearings, Oiler | 119 |
| Bearings, When they Run Hot | 114 |
| Beeman Garden Tractor | 87 |
| Bell, Welding a | 156 |
| Bellows, Ventilating Mine with | 147 |
| Belts, Finding Length of | 78 |
| Belts, Splicing Sand | 225 |
| Bench Catch-all | 269 |
| Bench Crane | 145 |
| Bench Drill, Post | 167 |
| Bending Attachments, Anvil | 118 |
| Bending Jaws, Vise | 284 |
| Bick Horn, Making a | 307 |
| Bicycle Tire Anti-leak | 65 |
| Black Iron Varnish | 299 |
| Blackening Zinc for Laying-out | 39 |
| Blacksmith Wears White Collar | 49 |
| Blacksmith, The Overseas | 161 |
| Blue Enamel, Steel | 273 |
| Bluing Gun Barrels | 221 |
| Body, Auto Made of Huge Redwood .. | 201 |
| Body Irons, Ready Made | 165 |
| Body Polish, Liquid | 186 |
| Body, Two Ton Truck | 228 |
| Boiler, Emergency Repair | 195 |
| Boiler, Testing a | 129 |
| Bolts, Handling Tire | 292 |
| Bosch Magneto on Ford | 103 |
| Bottles, Cleaning Stained | 169 |
| Box, Shoeing | 25 |
| Brake, Adjusting | 120 |
| Brake Lining Hint | 86 |
| Brass, Flux for | 39 |
| Brass, to Color Gray | 65 |
| Break Pins, Safety | 23 |
| Breather, Protecting the | 8 |
| Brazing Solder, White | 39 |
| Broken Axle, Towing Car with | 153 |
| Broken Carburetor Glass, Repairing, | 234, 271 |
| Broken Pitchfork, Repairing | 156 |
| Broken Studs, Removing | 151 |
| Bronze Connecting Rods | 155 |
| Bronze Collar on Steel | 195 |
| Brown Finish on Steel | 221 |
| Building up Bearings | 117 |
| Building Small Garage and Repair shop | 190 |
| Building Trailer from Old Chassis .. | 136 |
| Business Builders, Ten Little | 205 |

Burning Storage Battery Connections 130
 Bushings, Applying Connecting Rod.. 222
 Bushings, Pulling Old .. 170
 Bushings, Tightening Wristpin .. 21

C

Camping Car .. 263
 Can, Lantern Made From .. 206
 Can Tipper .. 292
 Cans, Uses for Empty .. 188
 Caps, Sticking Valve .. 23
 Caps and Valves .. 136
 Car, Camping .. 263
 Car, Legal Considerations in Sale of Used .. 76
 Cars, Overhauling .. 89, 137, 188
 Cars, Towing with Broken Axle .. 153
 Carbon Removers .. 103, 208
 Carburetor Adjustments of 20 Cars.. 16
 Carburetor Glass, Repairing Broken.. 234, 271
 Care of Bearings .. 81
 Care of Tractor .. 174
 Casehardening and Chilling .. 88
 Casehardening Cold Rolled Steel.... 143
 Casehardening for Colors .. 221
 Cashing Checks .. 305
 Casings, Using Old Tire .. 267
 Casting, Welding Cylinder .. 289
 Cast Iron Repairing .. 221
 Catch-all, Bench .. 269
 Causes for Overheating .. 152
 Celluloid, Writing on .. 39
 Cement, Auto Radiator .. 192
 Cement, Iron to Marble .. 221
 Cement, Leather or Paper to Pulleys. 169
 Cement, Switch-board .. 117
 Centering Rig, Stock .. 284
 Centers, Test .. 197
 Chain, Removing Speedometer .. 181
 Chain, Saving Tire .. 267
 Charcoal for Grinding .. 51
 Chart, Horsepower .. 299
 Chassis, Trailer Made from Old .. 136
 Checks, Cashing .. 305
 Checks, Payment of Forged .. 102
 Chevrolet 490 Electric System .. 42
 Chile, Shoeing in .. 112
 Chilled Mould Boards, Drilling .. 306
 Chilling and Casehardening .. 88
 Chimney Flues, Notes On .. 306
 Chisels, Cold .. 7, 100, 218
 Chisels, Made from Ford Magnets.... 47
 Christmas-tree Holder .. 70
 Circular Saws, Fitting Small .. 302
 Clamp, Adjustable .. 222
 Clamp, Drill Press .. 284
 Clamp, Hardening for Plow Lays ... 4
 Clamp, Holding Large Shafts .. 232
 Cleaning, Exhaust .. 8
 Cleaning, Gasoline Blow-torches .. 214
 Cleaning Gauge Glasses .. 307
 Cleaning, Jewelry, Etc. .. 65
 Cleaning, Paste, Hand .. 273
 Cleaning, Stained Bottles .. 169
 Cleaning, Steel .. 13
 Clear Windshield, Keeping .. 37
 Clip Repair, Spring .. 4
 Clogged Radiator .. 78
 Clutch, Slipping Ford .. 306
 Clutches, Cone .. 3
 Clutches, Removing Ford Springs... 33
 Clutches, Slipping .. 155
 Coating Solution, Copper .. 117
 Cold Chisels .. 7, 100, 218
 Cold Rolled Steel, Casehardening... 143
 Cold Tinning .. 273
 Cold Weather Vaporizer .. 8
 Collapsed Radiator Hose .. 197
 Coloring Brass Gray .. 65
 Coloring Metal Work .. 299
 Colors, Casehardening for .. 221
 Colors on Steel, Alloys for Drawing.. 39
 Colorado, Prices in .. 129
 Combination Hammer .. 196

Compound, Hardening .. 143
 Compound, Modeling .. 221
 Compound, Steel Welding .. 51
 Compound, Storage Battery Sealing. 9
 Compressed Acetylene, Manufacture of 23
 Concrete Engine Base .. 104
 Concrete Floors, Oil Stains on..... 195
 Cone Clutches .. 3
 Connecting Rods, Applying Bushings 222
 Connecting Rods, Bronze .. 155
 Connections, Burning Storage Battery 130
 Contracts of Minors .. 128
 Cooling Large Bearings .. 223
 Cooling System Trouble .. 267
 Copper Coating Solution .. 117
 Copper, Etching on .. 65
 Copper, Hardening .. 91
 Copper, Oxidizing .. 306
 Cork, Cutting .. 143
 Corner Signals, Street .. 57
 Cost Accounting, Value of .. 282
 Cotter Puller .. 292
 Covering Capacity of Paint .. 221
 Crane, Bench .. 145
 Crank Case Supports, Ford .. 100
 Crank Case, Welding an Aluminum.. 276
 Creeper, Tool Tray for .. 222
 Cutters, Wire .. 197
 Cutting Cork .. 143
 Cutting Gaskets and Circles .. 196
 Cutting Glass Tubing .. 170
 Cutting Rivets .. 21
 Cutting Threads to Shoulder .. 7
 Cutting Wire and Pins on Shaper... 144
 Cycle, Two .. 130
 Cylinder Casting Welding .. 289
 Cylinders, Lapping .. 211
 Cylinders, Leaks, Locating .. 13
 Cylinders, Re grinding, to Avoid .. 151

D

Degre of Grades .. 152
 Designing and Forging Tongs .. 201
 Devices for Economizing Fuel .. 98
 Dimmer, Ford Light .. 163
 Dirt Roads, Handling .. 164
 Distilling Water .. 18
 Doors, Hanging Shop and Garage... 58
 Double Reduction Gear Drive .. 32
 Drawing Temper in Sand .. 234
 Dressing Picks .. 25
 Drill, Bench Post .. 167
 Drill, Lengthening Twist .. 119
 Drill, Post Bench .. 167
 Drill, Press Clamps .. 284
 Drill, Repairing Air .. 135
 Drill, Tempering Twist .. 130
 Drilling Chilled Mould Boards.... 300
 Drilling Spring Steel .. 171
 Drilling True Holes in Metal .. 230
 Drive, Double Reduction Gear .. 32
 Driving Nails in Hardwood .. 86

E

Ebonizing Wood Handles .. 221
 Economizing Fuel, Devices for .. 98
 Electric Arc Welding .. 107, 147, 178
 Electric Horn, Ford .. 306
 Electric System, Chevrolet 490 .. 42
 Electric System, Ford .. 166
 Electric System, Hupmobile .. 85
 Emergency Boiler Repair .. 195
 Emergency Fuses .. 205
 Emergency Tire .. 141
 End Wrench, Open .. 196
 Emery Cloth, Mounting .. 91
 Empty Cans, Uses for .. 188
 Enamel Glaze for Coating Pans .. 39
 Enamel, Steel Blue .. 273
 Engine Base, Concrete .. 104
 Engine, Gas, Experiences .. 162
 Engine, Misses Fire .. 207
 Engine, Running on Prestolite Tank.. 102
 Engine, Two Cycle .. 130

Engine, Warm, Economical .. 37
 England, Prices in .. 286
 Etching Copper .. 65
 Etching Fluid .. 143
 Exhaust, Cleaning .. 8
 Explosions, Storage Battery .. 225
 Express, Art's Overland .. 293
 Express, Rural Motor .. 100, 113
 Extractor, Key .. 118

F

Fastening File Handles .. 192
 Fastening Screws in Tile and Brick.. 13
 Fastening Wristpins .. 111
 Feed Pipe, Gasoline, Repair .. 27, 145
 File Handles, Fastening .. 192
 File, Making Knives from .. 286
 Finding Length of Belts .. 78
 Finding Pulley Speeds .. 77
 Finishing Steel Brown .. 221
 Fire Clay Mixture .. 221
 Fire Don't Weld .. 221
 Fire, Preventing .. 70
 First Automobile, The .. 139
 Fitting Circular Saws .. 302
 Flange Wrench, Pipe .. 145
 Flanging Oil Pipes .. 171
 Flexible Shaft .. 223
 Flues, Chimney, Notes On .. 306
 Fluid, Etching .. 143
 Flux for Brass .. 39
 Flux Handy .. 126
 Flux, Welding .. 299
 Ford, Bosch Magneto for .. 103
 Ford Clutch, Slipping .. 306
 Ford Clutch Springs, Removing ... 33
 Ford Crank Case Supports .. 100
 Ford Electric Horn .. 306
 Ford Electric System .. 166
 Ford Engine Misses Fire .. 207
 Ford Light Dimmer .. 163
 Ford Magnets, Chisels from .. 47
 Ford Magnets, Installing .. 78
 Ford Magnets, Re-magnetizing .. 77
 Ford Radius Rods, Straightening .. 200
 Ford Steering Gear, Adjusting .. 24
 Fordson Tractors, Repairing .. 187
 Forge, Makeshift .. 284
 Forged, Checks, Notes, etc., Payment of .. 102
 Forging and Designing Tongs .. 201
 Forming Pump Leathers .. 197
 Foundation, Unusual Power Hammer 150
 Four Years of Smithing Under Fire.. 55
 France, Convoy Workshop Experience in .. 18
 France, Smithing in .. 135
 Freezing Solution, Anti- .. 96, 112
 Front Wheels, Lining Up .. 207, 234
 Frozen Pipes, Thawing .. 144
 Fuel, Devices for Economizing .. 98
 Fuel Line Repair .. 27, 145
 Funnel, Non Spilling .. 222
 Fuses, Emergency .. 205

G

Garage Pits, Danger from .. 227
 Garage and Repair Shop, Building a Small .. 190
 Garage and Shop Doors, Hanging ... 58
 Garden Tractor, Beeman .. 87
 Gas Engine Experiences .. 162
 Gas Hose Rack .. 223
 Gas, Manufacture of Compressed Acetylene .. 23
 Gasket and Circle Cutter .. 196
 Gasket Punch .. 144
 Gasoline Blow-torches, Cleaning.... 214
 Gasoline Rate Table .. 297
 Gasoline Tank Adjustment .. 36
 Gauge Glasses, Cleaning .. 307
 Gear, Assembling Magneto .. 213
 Gear, Double Reduction Drive .. 32
 Gear, Quieting Worn .. 110
 Generators, Oxygen .. 77

| | | | | | |
|--|----------|---|----------|--|----------|
| Glare, Lessening Headlight | 37 | Ignition Timing and Valve Setting.. | 5 | Manufacture of Compressed Acetylene | |
| Glass Tubing, Cutting | 170 | Ignition, Truck | 156 | Gas | 23 |
| Glass, Repairing Broken Carburetor | 234, 271 | Implement Hitches | 191 | Marble, Cementing Iron to | 221 |
| Glasses, Cleaning Gauge | 307 | Implement Selling | 230 | Market Garden Tractor, Beeman..... | 87 |
| Glassy Valve Seats, Grinding | 153 | Impressions, Making Wax | 13 | Marking Polished Steel | 195 |
| Glaze, Enameling for Coating Pans .. | 39 | Income Tax Problems, Answers to.. | 154 | Melting Brass | 181 |
| Glue, Preparing | 117 | Installing Ford Magnets | 78 | Metal Polish, Liquid | 169 |
| Glue, Substitute for | 39 | Insulation, Tire Filler as | 78 | Metal Shears, Sheet | 171 |
| Grades, Degrees of | 152 | Inventories Increase Profits..... | 268 | Metal Silvering Paste | 273 |
| Gray, Coloring Brass | 65 | Iron, Cementing to Marble | 221 | Metal Work, Coloring | 299 |
| Grinding, Charcoal for | 61 | Iron, Ready Made Body | 165 | Metal-working, tips in | 33 |
| Grinding Cylinders, to Avoid | 151 | Iron, Repairing Cast | 221 | Methods of Annealing | 47 |
| Grinding Glassy Valve Seats | 153 | Iron, Turning Very Hard | 169 | Mica, Undercutting on Commutators, | 32 |
| Grinding High Speed Steel | 102 | Iron Varnish, Black | 299 | Micographs | 83 |
| Grinding Valves | 197 | Iron, Welding Rod for Malleable..... | 78 | Micographs | 83 |
| Grinder, Valve | 223 | Iron Work, Varnish for | 273 | Miles Traveled in Plowing 1 Acre.... | 176 |
| Grinding Wheels | 306 | Iron, Wrought, Welding to Steel ... | 273 | Mine, Ventilating with Bellows | 147 |
| Growing Pistons | 211 | Iron, Wrought, Welding to Wrought | 286 | Minors, Contracts of | 128 |
| | | Iron | 286 | Mixing Plaster of Paris | 78 |
| | | | | Mixtures, Anti-freeze | 96, 112 |
| H | | J | | Modeling Compound | 221 |
| Hammer, Combination | 196 | Jaw, Bending, Vise | 284 | Modern Cold Chisels | 100 |
| Hammer Foundation, Power | 150 | Jaw, Taper, Vise | 118 | Motor Auxiliator | 144 |
| Hammer Handles, Treating | 207 | Jaw, Tubing, Vise | 148 | Motor Express, Rural | 100, 113 |
| Hammer, How I Built My Own Power | 29, 71 | Jewelry, Cleaning, Etc. | 65 | Motorcycle Hill Climb | 169 |
| Hand Cleaning Paste | 273 | Joints, Steam-tight | 91 | Mould oBards, Drilling Chilled..... | 306 |
| Handles, Ebonizing Wood | 221 | Judging Steel | 65 | Mounting Emery Cloth | 97 |
| Handles, Fastening File | 192 | | | Muffler, Home-made | 205 |
| Handles, Treating Hammer | 207 | | | | |
| Handling Dirt Roads | 164 | K | | N | |
| Handy Flux | 126 | Keep Batteries Charged in Winter.. | 101 | Nails, Driving in Hard Wood | 86 |
| Hanging Shop and Garage Doors.... | 58 | Keeping Bearings Cool | 223 | Nomenclature, Welding | 296 |
| Hard Rubber, Shrinking and Punch | 13 | Keeping Windshield Clear | 37 | Non-spilling Funnel | 222 |
| ing | 13 | Key Extractor | 118 | Note, Holder in Due Course can En- | 10 |
| Hard Steel and Iron, Turning | 169 | Knives Made from Files | 286 | force Payment | 10 |
| Hardening Bath, Acid | 143 | | | | |
| Hardening, Chilling and Case | 88 | L | | O | |
| Hardening Clamp for Plow Lays | 4 | Lantern Made from Tin Can | 206 | Oil, Lubricating for Winter Use | 91 |
| Hardening Compound | 143, 286 | Lapping Cylinders | 211 | Oil Pipe Flanging | 171 |
| Hardening Copper | 91 | Lathe Center Lubricant | 117 | Oil Stains on Concrete Floors | 195 |
| Hardening Paste for High Speed Steel, | 169 | Lathe Stop | 145 | Oil Stones, Truing | 221 |
| Hardening Plow Shares | 51 | Lawn Mower Repair | 214 | Oilers, Bearing | 119 |
| Hardening, Welds | 233 | Laying out, Blackening Zinc for ... | 39 | Old Rails, Uses for | 145 |
| Hardness and Wear | 62 | Lays, Hardening Clamp for Plow ... | 4 | Open End Wrench | 196 |
| Hardwood, Driving Nails in | 86 | Leaf Spreader, Spring | 192 | Open Price Policy of Trade Associa- | 206 |
| Hatchet, Ice | 170 | Leaks, Locating Cylinder | 13 | tion | 206 |
| Headlight Glare, Lessening | 170 | Leather, Cementing to Pulleys..... | 169 | Overhauling the Automobile ..89, 137, | 188 |
| Heating Babbitt | 165 | Leather, Forming Pump | 197 | Overhead, Balancing the | 224 |
| High Speed Steel, Grinding | 102 | Leather Renovator | 195 | Overheating and its Causes | 152 |
| High Speed Steel, Hardening Paste .. | 169 | Leather, Waterproofing | 91 | Overseas Blacksmith, The | 161 |
| High Speed Steel, Welding to High | | Legal Considerations in Sale of Used | | Ox Shoeing in Chile | 112 |
| Carbon | 155 | Cars | 76 | Oxidizing Copper | 306 |
| History of Oxyacetylene Welding.... | 34 | Length of Belt, Finding | 78 | Oxyacetylene Welding, History of... 34 | |
| Hitches, Implement | 191 | Lengthening Twist Drill | 119 | Oxygen Generators | 77 |
| Holder, Christmas-tree | 70 | Lessening Headlight Glare | 37 | | |
| Holder, in due Course, Can Enforce | | License Plates from All the States... 274 | | P | |
| Note Payment | 10 | Light Dimmer, Ford | 163 | Packing Screw | 284 |
| Holder, Washer | 118 | Light Reflector | 197 | Pads, Rubber Pedal | 145 |
| Holding Screws | 39 | Lining Brakes | 86 | Page from Yesterday, A | 138 |
| Holes, Drilling True, in Metal | 230 | Lining up Front Wheels | 207, 234 | Paint, Covering Capacity of | 221 |
| Holes, Sizing Threaded | 124 | Liquid Body Polish | 186 | Paint Remover | 37, 91 |
| Hoist, Hydraulic | 176 | Liquid Metal Polish | 169 | Paint Spray | 170 |
| Hoist, Portable | 196 | Locating Cylinder Leaks | 13 | Paint, Waterproof for Plaster..... | 273 |
| Horn, Ford Electric | 306 | Locating Punctures | 144 | Painting Automobiles | 149 |
| Horn, Making a Bick | 307 | Locking Screws | 164 | Pans, Enamel Glaze for Coating | 39 |
| Horsepower Chart | 299 | Loosening Pasted Paper | 195 | Paper, Loosening Pasted | 195 |
| Horseshoer, The Army ...22, 48, 101, | 125 | Lubricating Oil for Winter Use | 91 | Paste, Hand Cleaning | 273 |
| Horseshoing, Andean | 280 | Lubricating Valve Stems | 39 | Paste, Hardening for High Speed Steel, | 169 |
| Horses and Tractors | 63 | Lubricating Lathe Centers | 117 | Paste, Metal Silvering | 273 |
| Horses, Why I Quit Shoeing | 146 | | | Paste, Razor Strop | 65 |
| Hose, Collapsed Radiator | 197 | M | | Paste, Soldering | 145 |
| Hose Rack, Gasoline | 223 | Magneto, Bosch on Ford | 103 | Paste, Soldering, for Copper Wires.. | 39 |
| Hot Bearings | 114 | Magneto Gears, Assembling | 213 | Pasted Paper, Loosening | 195 |
| Hot Weather Truck Hints | 266 | Magnets, Chisels from Ford | 47 | Patternmaking, Plaster of Paris for.. | 13 |
| How I Built My Own Power Hammer, | 29, 71 | Magnets, Installing Ford | 78 | Payment of Notes, Checks, Etc. | 10, 102 |
| How Inventories Increase Profits | 268 | Magnets, Re-magnetizing Ford | 77 | Pedal Pads, Rubber | 145 |
| Hupmobile Electric System | 85 | Magneto, Bosch on Ford | 103 | Picks, Dressing | 25 |
| Hydraulic Hoist | 175 | Magneto, Why a | 125 | Pins, Cutting with Shaper | 144 |
| | | Makeshift Forge | 284 | Pins, Safety Break | 23 |
| | | Making a Bick-Horn | 307 | Pipe, Feed, Repairing | 27, 145 |
| I | | Making Tractor Starting Easy | 68 | Pipe Flanges, Wrench for | 145 |
| Ice Hatchet | 170 | Malleable Iron, Welding Rod for.... | 78 | Pipe, Oil, Flanging | 171 |
| Ideas, Welding Shop | 159 | Management, Shop | 119 | Pipe, Thawing Frozen | 144 |
| Ignition Systems | 185 | Manifold, Portable Plug Board | 119 | Pipe, Polished, Wrench for | 222 |

Pistons, Growing 211
 Pitch-fork, Repairing Broken 156
 Pits, Danger from Garage 227
 Plaster of Paris, Mixing 78
 Plaster of Paris for Patternmaking... 13
 Plaster, Waterproof Paint for 273
 Plates, Automobile License 274
 Plow Lays, Clamp for Hardening 51
 Plow Shares, Hardening 51
 Plowing 1 Acre, Number of Miles Traveled 176
 Plug Board, Portable Electric 119
 Plug, Radiator Repair 37
 Plug, Spark, Measuring 7
 Polish Auto Body 186
 Polish, Liquid Metal 169
 Polish, Spray 170
 Polished Pipe, Wrench for 222
 Polished Steel, Marking 195
 Portable Hoist 196
 Portable Workbench 144
 Post Drill, Bench 167
 Post Jack, Tool 292
 Power Hammer, How I Built My Own, 29, 71
 Power, Source of 306
 Preheating, Welding Without 155
 Preparing Glue 117
 Press, Arbor 119
 Prestolite Tank, Running Engine on.. 102
 Preventing Cylinder Grinding 151
 Preventing Fires 70
 Preventing Rust on Tools 145, 169
 Prices in Alabama 51
 Prices in Colorado 129
 Prices in England 285
 Prices in South Africa 24
 Process, Silvering 117, 273
 Profits, Inventories Increase 268
 Protecting the Breather 8
 Puller, Bearing 304
 Puller, Cotter Pin 292
 Pulley, Cementing Leather to..... 169
 Pulley, Finding Speed of 77
 Pulling Old Bushings 170
 Pump Leathers, Forming 197
 Punch, Gasket 144
 Punch, Vise 292
 Punching Hard Rubber 13
 Punctures, Locating 144

Q

Quieting worn gears 110

R

Rack, Gasoline Hose 223
 Radiator Cement, Auto 192
 Radiator, Clogged 78
 Radiator, Hose, Collapsed 197
 Radiator Repair Plug 37
 Radiator Cement Stand 180
 Radiator Repair, Tubular 94
 Radiator Thermostats 35
 Radius Rods, Straightening Ford 200
 Rails, Uses for Old 145
 Rainy Day Musings 31
 Rate Table, Gasoline 297
 Razor Grinding and Sharpening... 229, 281
 Razor Strop Paste 65
 Ready Made Body Irons 165
 Reduction Gear Truck Drive, Double.. 32
 Redwood, Auto Body Made from Huge 201
 Refacing Anvils 156
 Reflector, Light 197
 Repairing Air Drills 135
 Repairing Boiler, Emergency 195
 Repairing Cast Iron 221
 Repairing Feed Pipe 23, 145
 Repairing Fordson Tractors 187
 Repairing Lawn Mower Wheel 214
 Repairing Pitch-fork 156
 Repairing Radiators, Tubular 94
 Repairing Spring Clip 4
 Repairing Storage Batteries 8, 15, 41, 49, 74, 99

Repairing, System in 128
 Repairing Tractors 215
 Repairing Tubular Radiators 94
 Re-magnetizing Ford Magnets 77
 Removing Broken Studs 151
 Removing Carbon 103
 Removing Paint 37, 91
 Removing Rim Rust 86
 Removing Speedometer Chain 181
 Removing Valves 85
 Remover, Alcohol as Carbon 208
 Renovator, Leather 195
 Repair Shop, Building Small..... 190
 Repair Stand, Radiator..... 180
 Repeating Tools 39
 Re-setting Springs 285
 Rim Rust, Removing 86
 Rims, Squeaky 19
 Rims, Straightening Auto 215
 Roads, Bad 133
 Roads, Handling Dirt 164
 Rock Drills, Tempering 39
 Rods, Connecting, Bronze 155
 Rubber Pedal Pads 145
 Rubber, Hard, Shrinking and Punching 13
 Rubber Valve Spring 115
 Running Engine on Prestolite Tank.. 102
 Rural Motor Express 100, 113
 Rust, Preventing on Tools 145
 Rust, Removing Rim 86

S

Safety Break Pins 23
 Sand Belts, Splicing 225
 Sand, Drawing Temper in 234
 Saws, Fitting Small Circular 302
 Saw for Cutting Short Lengths 204
 Scale, Anti 13
 Screws, Fastening in Tile and Brick.. 13
 Screws, Holding 39
 Screws, Locking 164
 Screws, Packing 284
 Sealing Compound, Storage Battery.. 9
 Seating Valves, Tool for 222
 Selling Farm Implements 230
 Setting Springs 285
 Shaft, Clamp for Holding Large..... 232
 Shaft, Spanner 196
 Shaft Straightener 119
 Shares, Hardening Plow 51
 Sharpening and Grinding Razors... 229, 281
 Shear, Sheet Metal 171
 Sheet Metal, Shears 171
 Shellac Varnish, Improving Color of 273
 Shoeing, Andean 280
 Shoeing Box 25
 Shoeing, Chilean 112
 Shoeing, Why I Quit 146
 Shop, Anthony Zeman, His 59
 Shop Doors, Hanging 98
 Shop Management 96
 Shop, Welding, Ideas 159
 Shop, Wrinkles 57
 Shoulder, Cutting Threads to 7
 Shrinking and Punching Hard Rubber 14
 Signals, Street Corner 57
 Sizing Threaded Holes 124
 Silvering Paste 273
 Silvering Process 117
 Skeleton Wrench 119
 Slipping Clutch 155
 Slipping Clutch, Ford 306
 Small Garage and Repair Shop, Building 190
 Smithing, Four Years Under Fire ... 135
 Smoke Indicates Trouble 153
 Soft Steel, Weight of Round Bars... 37
 Solder, Aluminum 273, 286
 Solder, White Brazing 39
 Soldering Aluminum 285, 295
 Soldering Paste 145
 Soldering Paste for Copper Wires ... 39

Solutions, Anti-Freeze 96, 112
 Solutions, Copper Coating 117
 Source of Power 306
 Spanner, Shaft 196
 Spark Plugs, Measuring 7
 Speeds, Finding Pulley 77
 Speedometer Chain, Removing 181
 Splicing Sand Belts 225
 Spray, Polish 170
 Spreader, Spring Leaf 192
 Spring Clip Repair 4
 Spring Overhauling 137
 Spring Steel, Drilling 171
 Springs, Automobile, The Steel in.. 20, 45
 Springs, Clutch, Removing Ford.... 33
 Springs, Removing Ford Clutch.... 33
 Springs, Resetting 285
 Springs, Rubber Valve 116
 Springs, Valve, Rubber 115
 Springs, Welding 156
 Square Steel Bars, Weight of 63
 Squeaky Rims 19
 Stained Bottles, Cleaning 169
 Stand, Radiator Repair 180
 Standardization of Wagon Treads ... 270
 Starter Trouble 207
 Starting-Lighting Systems 185
 Starting, Tractor, Making Easy 68
 Steam-driven Automobiles 172
 Steam-tight Joints 91
 Steel, Alloys for Drawing Colors on.. 39
 Steel, Automobile Springs 20, 45
 Steel, Blue Enamel 273
 Steel, Bronze, Coloring 195
 Steel, Brown Finish on 221
 Steel, Casehardening, Cold Rolled... 143
 Steel, Cleaning 13
 Steel, Coloring Bronze 195
 Steel, Drilling Spring 171
 Steel, Grinding High Speed 102
 Steel, Hardening Compound 286
 Steel, High Carbon, Welding to High Speed 155
 Steel, High Speed, Grinding 102
 Steel, High Speed, Welding to High Carbon 155
 Steel, High Speed, Hardening Paste for 169
 Steel, Judging 110
 Steel, Marking Polished 195
 Steel, Paste for Hardening High Speed, 169
 Steel, Polished, Marking 195
 Steel, Tool, Economizing 13
 Steel, Turning Very Hard 169
 Steel, Very Hard, Turning 169
 Steel, Weight of Round Bars 37
 Steel, Weight of Square Bars 63
 Steel, Welding Compound 51
 Steel, Welding to Wrought Iron..... 273
 Steering Gear, Ford, Adjusting 24
 Stems, Valve, Lubricating 39
 Sticking Valve Caps 23
 Stitches in Time 65
 Stock Accounts 151
 Stock Centering Rig 284
 Storage Battery Connections, Burning, 130
 Storage Battery Explosions 225
 Storage Battery Repairing 8, 15, 41, 49, 74, 99
 Storage Battery Sealing Compound .. 9
 Stove Made of Stove-pipe 197
 Stove-pipe, Stove Made from 197
 Straightener, Shaft 119
 Street Corner Signals 57
 Straightening Auto Rims 215
 Straightening Ford Radius Rods ... 200
 Strop Paste, Razor 65
 Studs, Removing Broken 151
 Substitute for Glue 39
 Support, Ford Crank case 100
 Support, Work 118
 System, Cooling Trouble 267
 System Repair 128
 Symbols, Welding 296
 Switchboard Cement 117

T

Table, Gasoline Rate 297
 Tank, Gasoline, Adjustment of 36
 Taper Vise Jaws 118
 Tax Problems, Answers to Income .. 154
 Temper Drawing in Sand 234
 Tempering Rock Drills 39
 Tempering Twist Drills 130
 Ten Little Business Builders 205
 Test Centers 197
 Testing, Boiler 129
 Thawing Frozen Pipes 144
 Thermostats, Radiator 35
 Threaded Hole, Sizing a 124
 Threads, Cutting to Shoulder 7
 Tightening Wristpin Bushing 21
 Timing Ignition and Valves 5
 Tin Can Lantern 206
 Tinning, Cold 273
 Tips in Metal Working 33
 Tire, Anti-leak, Bicycle 65
 Tire, Bicycle Anti-leak 65
 Tire, Emergency 141
 Tire Fakery Bared 269
 Tire, Filler as Insulation 78
 Tipper, Can 292
 Tire Bolts, Handling 292
 Toe in of Auto Wheels 51
 Tongs, Designing and Forging 201
 Tool Post Jack 292
 Tools, Preventing Rust on 145
 Tools, Re-pointing 39
 Tools, Steel, Economizing 13
 Tools, Tray for Creeper 222
 Torches, Cleaning Gasoline 214
 Towing Car with Broken Axle 153
 Tractor, Acres Plowed in 1 Day ... 231
 Tractor, Beeman Garden 87
 Tractor, Care of 174
 Tractor, Fordson, Repairing 187
 Tractor, Horses and 63
 Tractor, Implement Hitches 191
 Tractor, Life of Average 11
 Tractor, Market Garden 87
 Tractor Repair Hints 215
 Tractor, Trundaar 48
 Trade Association Open Price Policy, 206
 Trailer Built from Old Chassis 136
 Tread, Standardized Farm Wagon... 270
 Treating Hammer Handles 207
 Tree Holder, Christmas 70
 Trouble in Cooling System 267
 Trouble, Smoke Indicates 153
 Trouble, Starter 207
 Truck Body, Two-ton 228
 Truck Hot Weather Hints for 266
 Truck Ignition 156
 True Holes, Drilling in Metal 230
 Truing an Oil Stone 221
 Trundaar Tractor 48
 Tubing, Cutting Glass 170
 Tubing, Vise Jaws for 148
 Tubular Radiators, Repairing 94
 Turning Very Hard Iron and Steel .. 169
 Twist Drill, Lengthening 119
 Twist Drill, Tempering 130
 Two Cycle Engine 130
 Two Welding Jobs in One Fire 198
 Two ton Truck Body 228

U

Under Fire, Four Years of Smithing, 55
 Undercutting Mica on Commutators.. 32
 Unusual Power Hammer Foundation, 150
 Used Cars, Legal Considerations in
 Sale of 76
 Uses for Old Cans 183
 Uses for Old Cans 145
 Using Old Casings 267

V

Value of Cost Accounting 282
 Valve and Caps 23, 136
 Valve Grinder 223

Valve Grinding 197
 Valve Lubricating, Stems 39
 Valve Removal 85
 Valve Seats, Grinding Glassy 153
 Valve Seating Tool 222
 Valve Stems, Lubricating 39
 Valve Timing and Ignition 5
 Vaporizer, Cold Weather 8
 Varnish, Black Iron 299
 Varnish for Ironwork 273
 Varnish, Shellac, Improving Color of 273
 Vaporizer, Cold Weather 8
 Ventilating Mine with Bellows 147
 Vise Jaws, Bending 284
 Vise Jaws, Tapering 118
 Vise Jaws, Tubing 148
 Vise Anvil 227
 Vise Helps 170
 Vise Punch 292
 Vulcanizing Helps 191

W

Wagon, Standardized Tread of Farm, 270
 Warm Engine Economical 37
 Washer Holder 118
 Watch Ammeter, The 39
 Water, Distilling 18
 Waterproofing Leather 91
 Waterproofing Plaster, Paint for... 273
 Wax Impressions 13
 Wear and Hardness 62
 Weight of Round Steel Bars 37
 Weight of Square Steel Bars 63
 Welding Aluminum 276
 Welding, Arc, Electric 107, 147, 178
 Welding, Bell 156
 Welding Compound, Steel 51
 Welding Cylinder Castings..... 289
 Welding, Electric Arc 107, 147, 178
 Welding Flux 299
 Welding High Carbon to High Speed
 Steel 155
 Welding High Speed, to High Carbon
 Steel 155
 Welding, History of Oxyacetylene ... 34
 Welding Nomenclature, and Symbols 296
 Welding Rod for Malleable Iron 78
 Welding Shop Ideas 159
 Welding Springs 156
 Welding Steel 83
 Welding Steel to Wrought Iron 273
 Welding Two Jobs in One Fire 198
 Welding Without Preheating 155
 Welding Wrought Iron to Wrought
 Iron 286
 Weld, Fire Won't 207, 233
 Weld, Hardening of 233
 Wheels, Grinding 306
 Wheels, Lining up Front 234
 Wheels, Toe in of Auto 51
 When Bearings Run Hot 114
 When Buyer Misrepresents Himself 180
 White Brazing Solder 39
 Why a Magneto? 125
 Why I Quit Shoeing Horses 146
 Windshields, Keeping Clear 37
 Winter, Keep Batteries Charged in.. 91
 Winter, Lubricating Oil for 91
 Wire Cutter 197
 Work Supports 118
 Work Bench, Portable 144
 Working Aluminum 91
 Working, Metal, Tips in 33
 Workshop Experiences in France ... 18
 Worm Gears, Quieting 110
 Wrench, Adjustable Open End .. 196
 Wrench, Pipe Flange 145
 Wrench, Polished Pipe 222
 Wrinkles, Shop 57
 Wristpin Bushings, Tightening 21
 Wristpin Fastenings 111
 Writing on Celluloid 39
 Wrought Iron Welding to Steel 273
 Wrought Iron, Welding to Wrought
 Iron 286

Y

Yesterday, a page from 138

Z

Zeman, Anthony, his shop 59
 Zinc, blackening for laying out 39

Volume 19

Begins with the October
 Number. Save each
 copy as you receive it.

A limited number of
 binders for preserving
 copies of the
 AMERICAN BLACKSMITH,
 AUTO & TRACTOR SHOP
 are available to readers
 at 50 cents each.

LINDE OXYGEN

From Coast to Coast "C" Producing Plants and Distributing Stations provide an unlimited supply of Linde Oxygen for users everywhere.

LINDE SERVICE means no investment except for oxygen actually received—no expensive overhead or upkeep charges.

Linde Oxygen may be obtained from any of the following Linde Plants and Distributing Stations where a large supply of charged 100 and 200 cu. ft. cylinders is kept on hand constantly to insure immediate shipments

Mail or telephone your order to THE LINDE AIR PRODUCTS CO., at the nearest point. Shipments will be made on day order is received.

Distributing Stations

- | | |
|--------------------------------|-----------------------------|
| Alabama | New Jersey |
| Birmingham (Plant) | Elizabeth |
| 10th Ave. & 28th St. | Linden Ave. |
| Colorado | Newark |
| Denver | 854 Plane St. |
| 1550 Glenarm St. | New York |
| District of Columbia | Albany |
| Washington | Montgomery & Colonie Sts. |
| 9th & Maryland Ave., S. W. | Brooklyn (Plant) |
| Georgia | 475 Driggs Ave (Plant) |
| Atlanta (Plant) | Buffalo (Plant) |
| Plyant St. & Southern R. R. | 155 to 183 Chandler St. |
| Savannah | New York City |
| Ogeechee Canal, So. of Bay St. | 217 W. 29th St. |
| Illinois | New York City (Bronx) |
| Chicago (Plant) | 3168 Park Ave. |
| 3633 Wall St. | Utica (Plant) |
| Chicago (North Side) | Walnut & Schuyler Sts |
| 113 Austin Ave. | Ohio |
| East St. Louis | Cleveland (Plant) |
| 6th & Walnut Ave. | E. 73rd & Bitten Ave. |
| Indiana | Cincinnati (Plant) |
| East Chicago (Plant) | Stanton & Mellish Aves. |
| Fort Wayne | Columbus |
| 414 E. Columbia St. | 310 Dublin Ave. |
| Indianapolis (Plant) | Dayton |
| 2819 Roosevelt Ave. | 521 E. First St. |
| Iowa | Toledo |
| Davenport | 414 S. Erie St. |
| 118 Harrison Street. | Oklahoma |
| Des Moines | Oklahoma City |
| 117 W. 5th Street | 27 E. Grand Ave. |
| Kansas | Tulsa |
| Wichita | 1 North Boulder St. |
| Rock Island Ave. & 2nd St. | Pennsylvania |
| Kentucky | Erie |
| Louisville | 1502 Sassafras St. |
| 126 E. Main St. | Norristown (Plant) |
| Louisiana | No. Philadelphia (Plant) |
| New Orleans | 18th & Cambria Sts. |
| 861 Fulton St. | Pittsburgh |
| Maryland | 16th & Pike Sts. |
| Baltimore (Plant) | Trafford (Plant) |
| 25th & Montebello Ave. | Tennessee |
| Massachusetts | Chattanooga |
| Cambridge | 212 to 238 King St. |
| 25 Waverly St. | Memphis |
| Springfield | 203 Washington St. |
| Napier St. | Wisconsin |
| Worcester (Plant) | Milwaukee (Plant) |
| 961 Southbridge St. | 36th St. & National Ave. |
| Michigan | PACIFIC COAST |
| Detroit (Plant) | California |
| St. Aubin Ave. & Newton St. | Emeryville, Oakland (Plant) |
| Grand Rapids | Los Angeles (Plant) |
| Pearl St. by the Bridge | 1405 Mission Road |
| Minnesota | Oregon |
| Duluth | Portland |
| Seventh Ave. West | 15th & Hoyt Sts. |
| Minneapolis (Plant) | Utah |
| 1809 E. Hennepin Ave. | Salt Lake City |
| Missouri | 112 W. Second St. South |
| North Kansas City (Plant) | Washington |
| 14th & Charlotte St. | Seattle |
| St. Louis (Plant) | 530 First Ave. South |
| 4218 Forest Park Blvd. | TEXAS |
| Nebraska | Texas |
| Omaha | Dallas (Plant) |
| 1007 Jones St. | Harwood & Coombs St. |
| | Houston |
| | Cedar & Baker Sts. |
| | San Antonio |
| | 512 Dolorosa St. |

Other plants and Distributing Stations are planned for other industrial centers throughout the country and will be established as fast as and wherever the local demand for oxygen warrants.

The Linde Air Products Company

Largest Producers of Pure Oxygen in America

Forty-Second St. Building, NEW YORK

We Tear 'em up and Sell the Pieces

We save you 50 to 75 per cent on auto repairs. Can supply most any part needed.

Our Guarantee—If not satisfactory, can be returned, and money refunded.

Auto Wrecking Co.

13th and Oak Sts., KANSAS CITY, MO.

A Ford Starter that's the real thing—the
SIMPLEX \$12.50
Trouble-Proof

STARTS the Ford from the seat. No cranking—no batteries—no kick. Easily and quickly attached—fits any Ford car.

Dealers! Here's a little wonder as a fast seller to Ford owners. You are fully protected by our positive guarantee. Write today for literature and trade discounts.

SIMPLEX MFG. CO.
Box 263 Anderson, Indiana



"SAVE THE PIECES!"

"All the King's horses and all the King's men couldn't put Humpty-Dumpty together again."

It's a "One-man" job to restore broken or cracked metal parts to their original value and usefulness with Economy Welding and Cutting Outfits and Economy Acetylene Gas Generators

MAKE YOUR OWN ACETYLENE

Using the Economy Acetylene Gas Generator you can make your own acetylene gas; make more of it, for less money, and with no freight or hauling charges. UNCLE SAM needs the acetone in compressed acetylene—needs it bad—needs all he can get. Economy Acetylene Gas Generators do not require acetone.

Write for prices and catalogs to

Economy Welding Machine Company

213 Southwest Boulevard, KANSAS CITY, MO.

Manufacturers of Welder's supplies and equipment of all kinds.

CUMMINGS & EMERSON
BLACKSMITH SUPPLIES
 Send for net price plow goods catalogue.
PEORIA, ILLINOIS

PATENTS **HERBERT JENNER,**
 Patent Attorney and Mechanical Expert, 622 F St., Washington, D. C. Established 1883. I make a free examination and report if a patent can be had and exactly what it will cost. Send for circular.

WANTED—New Ideas Write for How to Obtain a Patent. List of Patent Boys, Inventions Wanted and \$1,000.00 in prizes offered for inventions. Send sketch for FREE opinion of patentability. Our FOUR BOOKS sent free. Patents advertised FREE. Victor J. Evans Co., 686 Ninth, Washington, D. C.

PATENTS

C. L. PARKER
 Ex-Member Examining Corps, U. S. Patent Office
 Attorney-at-Law and Solicitor of Patents
 American and foreign Patents secured. Trade marks registered. Searches made to determine patentability, validity and infringement. Patent Suits conducted. Pamphlet of instructions sent upon request.
 McGill Building WASHINGTON, D. C.

PATENTS THAT PROTECT AND PAY . . .
 BOOKS, ADVICE, AND LIST OF INVENTIONS WANTED FREE.

Send sketch or model for search. Highest References. Best Results. Promptness Assured.
Watson E. Coleman, Patent Lawyer
 624 F Street N. W. Washington, D. C.



Simonsen Kold Kutter No. 1 is the handiest tool you could place on your bench. Made entirely of steel yet low in price. Will cut cold $\frac{1}{4}$ x 2 or $\frac{1}{4}$ x 6 in. mild steel. Write for our circular K and learn all about this bench shear.
SIMONSEN IRON WORKS.
 Sioux Rapids, Iowa, U. S. A.

WANTED AND FOR SALE

Want and For Sale advertisements, situations and help wanted, five cents a word. Send cash with order. No charge less than fifty cents. The small cost of these advertisements prevents our investigating and guaranteeing them. WE WILL NOT knowingly accept any but reliable ones.

FORDS START EASY IN COLD WEATHER with our new 1919 carburetors. 34 miles per gallon. Use cheapest gasoline or half kerosene. Increased power. Styles for any motor. Very slow on high. Attach it yourself. Big profits to agents. Money back guarantee. 30 days trial. **Air-Friction Carburetor Co., 388 Madison, Dayton, Ohio.**

WANTED—to buy a power hammer, Perfect or Little Giant. Must be in perfect condition and cheap. **C. A. Burke & Son, Elgin, Texas.**

FOR SALE—Well equipped electric power, two fire shop. Good location, lots of work. Price \$1600, half cash. Address **GEO. H. STEELE, Spearville, Kansas.**

FOR SALE—Blacksmith shop with good business for two men the year around. Write **L. McBRIDE, Belle Plaine, Ia.**

FOR SALE—Good blacksmith shop with power, tools, and stock. In a small town, doing a good business. Poor health reason for selling. For particulars write to **A. J. BOLLIER, Seafield, Ind.**

FOR SALE—Up to date woodworking shop, fully equipped with machinery and stock, in a good town of 5,000. For particulars address **W. F. B., care of American Blacksmith, Auto & Tractor Shop.**

FODEN'S MECHANICAL TABLES
SAVE ALL FIGURING!
 Tell at a glance how much stock to use for oval or elliptical hoops of any size, the circumferences of circles, weight of flat, square and round stock, and the weight and strength of ropes and chains. Should be in every progressive Smith's hands. Bound very neatly in green cloth. Price, 75c.
AMERICAN BLACKSMITH, AUTO & TRACTOR SHOP
 Buffalo, New York

ACCESSORIES AND SUPPLIES OF INTEREST TO THE TRADE.

Continued from Page 26.

A SAFE INVESTMENT

If your neighbor has a horse that is blemished and after two or three weeks of faithful treatment you see this same horse sound and in the best of spirits, doesn't it make you feel guilty to see your own horse "Down and Out" and you making no effort to relieve him?

This is the case with many horse owners. If they see a puff or bunch developing on their horse, instead of starting treatment immediately with a good, reliable liniment, they let it go, thinking that Nature will take care of it. The result in many cases is that the horse gets so bad that he is useless.

When using any kind of a liniment the first thing to be considered is, "is it safe?" Absorbine is perfectly safe and harmless and is composed of the best ingredients that can be purchased. A pamphlet of interest to horse owners will be sent to anyone upon request. If your case requires special directions or there is some point not made perfectly clear in the pamphlet, the manufacturers are always glad to take the matter up and suggest line of treatment for each individual case. Absorbine at druggists or postpaid \$2.50 a bottle. **W. F. Young, P. D. F., 230 Temple St., Springfield, Mass.**

TROUBLE SAVING TROUBLE HUNTER

From the letters that we receive and we get lots of them, the automobile electrical system is the bugbear and the bane of the repairman, not only because it is prone to trouble but when trouble does show up somewhere it is considerable of a job to hunt it down and find out just what is wrong.

One can find an engine knock without much trouble but as you can't see, feel nor hear things that go wrong with the electrical system one has to patiently test out the whole system wire by wire and part by part.

The things just said about electrical troubles do not apply to the repairman who is equipped with the Niehoff Detectometer. With the instrument just mentioned short circuits and other defects in armatures, slip rings, condensers and coils can be located exactly in a few seconds. This equipment is manufactured by the **Paul G. Niehoff & Co., Inc. 232 East Ohio St., Chicago, Illinois.**

In addition to their electrical testing equipment the Niehoff Company make thoroughly tested electrical parts that you are unable to obtain from the maker. They also do armature rewinding and make all repairs needed on starting and lighting motors and generators. Their charges for this work are reasonable and prompt and expert service can be expected of any work entrusted to them.

PEERLESS AUTOMOBILE SPECIALTIES are a line of quality products started about eight years ago with one product, namely, Peerless Mohair Top Dressing.

The line has gradually increased keeping pace with the steady line of products of this character until the line now included 28 articles covering goods to keep the whole car looking bright and new so that a used car can be made practically as new looking as one just received from the manufacturer and the work can be done by an Owner if they desire, but a large volume is handled and consumed by the Automobile Painter.

Continued on Page 40.

1918 Model The L. S. P. Calking Machine

The Greatest Time and Labor Saving Machine on Earth

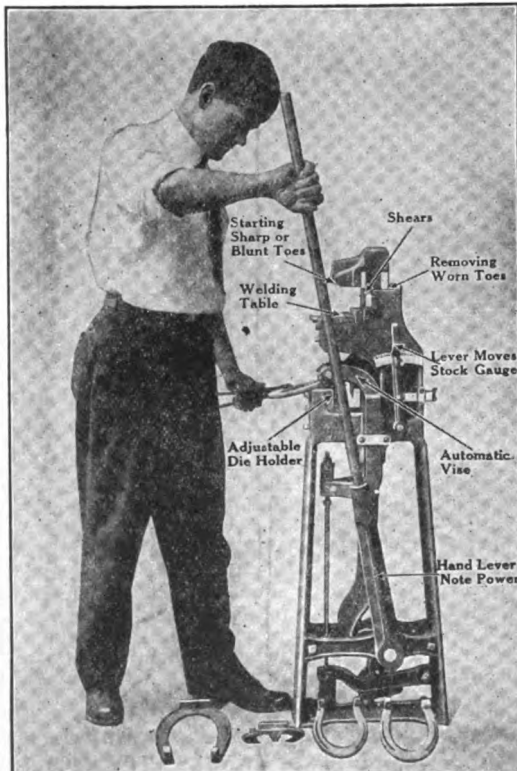

1918 MODEL
 Fully covered with Patents

OUR 1918 Model is the same as our 1917 Model with the exception that we have eliminated the steel plunger attachment and strengthened some of the parts.

Do not mistake this for a machine which makes toe calks or a foot vice. This machine is for turning heel calks, both Blunt and Sharp, sticking and welding toe calks, clipping and trimming ends of shoes. **IT CALKS SHOES,** doing the work just the same as you do by hand with the hammer, only it is done much better and easier, and in a fraction of the time.

In turning heels, you can turn up just as much stock as you wish, upset or stovcup to make as heavy as you like and square up the calks without use of hammer. There is no losing of toes when you weld on the L. S. P.

It is a strong, handsome, well-made machine, and will last, as you might say, a life time, fully warranted for one year. It is in use in the best shops in the United States, users claiming more for it than we do. Write at once for full information and prices.

L. S. P. CALKING MACHINE COMPANY

Peoples' State Bank Building
 Wyalusing, Pa., U. S. A.

National Machine Co.,
 Brighton, Ont., Canada

PHOENIX

Horse and Mule Shoes are used by most Good Shoers—because of their better material—are easier to fit and more uniform than the ordinary run of shoes

BULLDOG

Toe Calks are much better than the old-fashioned kind—"Take hold and never let go."

PHOENIX HORSE SHOE CO.

"NEW EASY" 4 Sizes BOLT CLIPPERS "EASY" 2 Sizes

THE GENUINE TOOL



KNOWN AND PREFERRED EVERYWHERE

H. K. PORTER EVERETT, MASS. U. S. A.

EMPIRE STEEL WHEELS

Plain or grooved Tire
To Fit Any Wagon
Farm Trucks
All Standard Types



Write today for Proposition to Blacksmiths.
Empire Mfg. Co.
P. O. Box 308
QUINCY, ILLINOIS

YOUR FINAL VERDICT Vulcanizers

MILLER'S or ANDERSON for every use.
80 - Page Catalog free on request.
Free Instructions.



Extra Ply Tires
Exclusive Territory Given.
Write, yours may be open.
Address Dept B
CHAS. E. MILLER, Anderson, Indiana.
1894 U. S. A.

COMPLETE CURE ONE HEAT
IMPROVED AIR-COOLED FLANGES

HAVANA STEEL WHEELS

For your Farm Wagon, so as to make it a Low-Down, instead of having to do your work over the sides of a high wheeled wagon. No dry, loose wheels. More and easier work done.
Send postal for free catalog of Steel Wheels and Farm Trucks.
HAVANA METAL WHEEL CO.,
Box 85 Havana, Ill.



ACCESSORIES AND SUPPLIES OF INTEREST TO THE TRADE.
Continued from Page 38.

Up to the present time these goods are in use by over 8,000 of the leading Automobile Paint shops in the country which is a very strong endorsement as to their quality, but we as manufacturers feel that it is also essential to give a practical man, like an Automobile Repair man or a Painter, a quality products to hold his future business. The splendid growth of of Peerless Automobile Specialties is credited to their quality and repeat orders from satisfied and practical consumers like Automobile Painters.

The goods include Mohair Top Dressings, Leather Top Dressings, Lining Dyes, Cushion Dressings, Lamp Enamels, Cylinder Enamels, Body Polishes, Fender Enamels, Rim Paints, Tire Paints, Gasket Shellacs and 8 color Varnishes for re-painting cars.

Address The Columbus Varnish Co., at Columbus, Ohio., for literature and full particulars of the Peerless line.

Four interesting and valuable books that have been added to our already long

The Wood Worker's Friend



Get directions for building table and operating our Jointer's. This information is valuable to wood workers. We manufacture 20 styles and sizes. Try a Jointer Head 30 Days, if you are not pleased, return at our expense. Get prices.
Mfg. by WHISLER MFG. CO., Gibson, Iowa

CLEAN YOUR ENGINE REGULARLY WITH A



Wagner Auto Engine Cleaner

One qt. kerosene and 6 lbs. air pressure cleans all dirt, grit and grease from engine. Prevents wear, actually saves half the usual repairs. Quick, economical, thorough, easy and cleanly to operate. Necessity for repair shops.
Wagner Specialty Co., 1962 Broadway, New York City

THE IMPROVED EASY HOOF TRIMMER

Will cut a hoof easier, quicker and better than any tool you have ever had. Weight 21-2 pounds, opening 2 inches, cuts one inch. Thousands of shoers are using the EASY HOOF TRIMMER with great satisfaction.
SEND \$1.50 TODAY
Delivered to any part of the U. S. by Parcel Post.
MUNCIE WHEEL CO., Muncie, Ind., U.S.A.



BALL AND ROLLER BEARINGS
All Types—IN STOCK—Many Sizes

THE GWILLIAM COMPANY
ENGINEERS
253 W. 58th St. (at Broadway) NEW YORK
Branch: 1314 Arch St., Philadelphia



list of publications that we can recommend are.

AUTOMOBILE IGNITION, STARTING and LIGHTING, with questions and answers, by Charles B. Hayward, Price \$2.50

This book contains 761 pages, 480 wiring diagrams in addition to a large number of other illustrations. Flexible leather binding. Written in popular style—easy to read and easy to understand. Describes completely the electrical equipment of the modern automobile, and contains wiring diagrams and details of all important ignition, starting and lighting systems. One of the best works on the subject we have seen for the repairman.



AUTOMOBILE CONSTRUCTION AND REPAIR—Including welding and vulcanizing, by Morris A. Hall. Price—\$2.50, 324 pages, 266 illustrations, flexible leather binding. A practical guide of repair methods of driving, road troubles, and making repairs including tire vulcanizing and autogenous welding. This volume is designed for the owner or the driver who wishes to care

for his car properly and for the repairman who is anxious to broaden his own experience.

FORGING—by John Jerberg, instructor in forging practice and heat treatment of steel, Worcester Polytechnic Institute, member Swedish Engineering Society, 145 pages, 206 illustrations, cloth binding, price \$1.00—A manual of modern forge practice including a thorough discussion of methods, equipment, welding, drop forging heat treating and tempering of steel and iron.

OXY-ACETYLENE WELDING PRACTICE—by Robert J. Kehl, M. E., 110 pages 117 illustrations, cloth binding, price \$1.00. A practical presentation of the modern processes of welding, cutting and lead burning with special attention to the technique for steel, cast iron, aluminum, copper and brass. This book gives full instructions for handling practically every kind of welding job. It is especially valuable to the **AUTO REPAIRMAN**, as the examples have been taken from the automobile industry—the field that lovers all classes of welding. However, any man interested in welding may easily apply to his own needs the information contained in this book.

Any of the above books will be mailed postpaid on receipt of price.

When Cray Brothers of 1111-1121 W. 11th. Street, Cleveland, Ohio, issued their 1918 catalog they intended it to be sent free, to any interested repairman or jobber who would write and mention the American Blacksmith, Auto and Tractor Shop. They also prepared a bulletin issued monthly to act as a supplement to the catalog.

The catalog is a truthful representation and description of the goods that are handled by them. It contains over 500 pages on carriage and auto supplies and tools, with net prices. Emphasis is also laid on the service that is rendered to every one in return for any order, no matter how small.

The bulletin issued in combination with this catalog not only contains special offers and seasonable goods but is a schedule of the changes that may occur from time to time in the prices cited in the catalog. In this manner keeping it up-to-date.

They have anticipated their customers requirements months ahead due to the shortages in steel, iron and other metals, so that they may be able to deliver on time.

Every progressive shop-repairman needs this catalog in order to keep right up on the prices and the new accessories constantly coming in, so if you haven't your copy get in line at once.

In writing for your copy of Cray Brothers' catalog, mention you are doing so at the advice of American Blacksmith, Auto & Tractor Shop.

ALUMINUM WELDED WITHOUT WARPING.

St. Louis has the distinction of having the only concern that has been able thus far to weld aluminum without warping or preheating. This is done by the American Welding Co., located at the North west corner of 23rd and Olive Streets.

for his car properly and for the repairman who is anxious to broaden his own experience.

FORGING—by John Jerberg, instructor in forging practice and heat treatment of steel, Worcester Polytechnic Institute, member Swedish Engineering Society, 145 pages, 206 illustrations, cloth binding, price \$1.00—A manual of modern forge practice including a thorough discussion of methods, equipment, welding, drop forging heat treating and tempering of steel and iron.

OXY-ACETYLENE WELDING PRACTICE—by Robert J. Kehl, M. E., 110 pages 117 illustrations, cloth binding, price \$1.00.

A practical presentation of the modern processes of welding, cutting and lead burning with special attention to the technique for steel, cast iron, aluminum, copper and brass. This book gives full instructions for handling practically every kind of welding job.

It is especially valuable to the **AUTO REPAIRMAN**, as the examples have been taken from the automobile industry—the field that lovers all classes of welding. However, any man interested in welding may easily apply to his own needs the information contained in this book.

Any of the above books will be mailed postpaid on receipt of price.

When Cray Brothers of 1111-1121 W. 11th. Street, Cleveland, Ohio, issued their 1918 catalog they intended it to be sent free, to any interested repairman or jobber who would write and mention the American Blacksmith, Auto and Tractor Shop. They also prepared a bulletin issued monthly to act as a supplement to the catalog.

The catalog is a truthful representation and description of the goods that are handled by them. It contains over 500 pages on carriage and auto supplies and tools, with net prices. Emphasis is also laid on the service that is rendered to every one in return for any order, no matter how small.

The bulletin issued in combination with this catalog not only contains special offers and seasonable goods but is a schedule of the changes that may occur from time to time in the prices cited in the catalog. In this manner keeping it up-to-date.

They have anticipated their customers requirements months ahead due to the shortages in steel, iron and other metals, so that they may be able to deliver on time.

Every progressive shop-repairman needs this catalog in order to keep right up on the prices and the new accessories constantly coming in, so if you haven't your copy get in line at once.

In writing for your copy of Cray Brothers' catalog, mention you are doing so at the advice of American Blacksmith, Auto & Tractor Shop.

ALUMINUM WELDED WITHOUT WARPING.

St. Louis has the distinction of having the only concern that has been able thus far to weld aluminum without warping or preheating. This is done by the American Welding Co., located at the North west corner of 23rd and Olive Streets.

Continued on Page 41.

Norton Wheels in the Blacksmith Shop

The wheel for the blacksmith shop must be adapted to a great variety of work in order to be economical.

The wheels usually recommended for general use in blacksmith shops are 24 P and 24 Q ALUNDUM, sometimes, however, a 30 P or Q is used to better advantage.

If a fair finish is desired, good results may be obtained with a 36 O ALUNDUM, but if the finish is to be fine, wheels 46 N or O are commonly used.

Wherever the speeds are low, a harder wheel will be found more satisfactory, but if possible, the wheels should be operated at 5000 to 6000 surface feet per minute.

Norton Company Worcester, Mass.

NEW YORK STORE
151 CHAMBERS STREET

CHICAGO STORE
11 N. JEFFERSON STREET

ELECTRIC FURNACE PLANTS
NIAGARA FALLS, N. Y. CHIPPEWA, ONT., CANADA



873

ACCESSORIES AND SUPPLIES OF INTEREST TO THE TRADE.

Continued from Page 40.

The business was established in 1903 by H. G. Donigan who was the first man to bring the welding torch from Paris to America 16 years ago and which is still in his shop and which he has greatly improved since. He is also the first man in the United States to do cast iron brazing.

Mr. Donigan is an inventor of note and has a secret process that enables him to

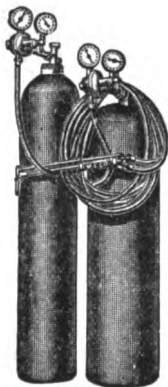

weld aluminum and cast iron without pre-heating. He was successfully welding aluminum with city gas and oxygen before acetylene welding was invented.

The American Welding Co., manufactures oxy-acetylene welding and cutting machines of all capacities, both stationary and portable.

All machines manufactured by them are generating machines and each consists in

general of oxygen generator, acetylene generator welding and cutting blow-pipes, necessary fittings and accessories complete.

This company maintains a very large repair shop in connection with their welding plant and are in a position to care for any kind of welding repairs.

WHY IS A BROKEN SPRING?

When a customer brings his car into your shop with a broken spring do you ever stop to consider just what's back of that break? The reason is easy to find if one considers that no spring, no matter how perfect, can be constructed to adjust itself to maximum loads over the roughest roads and at the same time be flexible enough to give buoyancy and comfort on moderately bad roads. In achieving the first, comfort is lost; in providing for the second, the greatest possible strength is mitigated. Hence, there is always present the danger of sudden breakage under severe conditions of service.

PAMCO QUADRUPLE SPRING UNIVERSAL SHOCK ABSORBERS furnish just the happy medium to provide the greatest degree of comfort and to give added strength. Anyone who has driven a car very far quickly realizes the need for a good shock absorber and it is an easy matter for the repairman to convince his customers that they should have their cars equipped with PAMCOS. With practically no arguing at all, he can sell a set to every motorist who has broken springs repaired at his shop.

Pamco Shock Absorbers are built for every type of passenger and commercial car and the same benefits are derived in either class.

The duplex spring construction is such that a Pamco Shock Absorber absorbs more than three times the capacity of any leaf spring and it gives the same results whether car is empty or loaded. A special meritorious feature is the open construction which does away with the accumulation of grease in the usual dust-

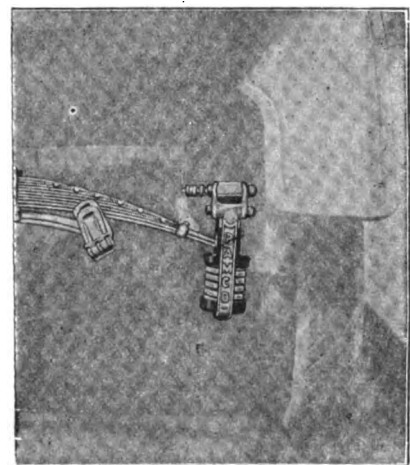

tight protector type. In fact, the use of grease is done away with altogether.

There are so many excellent features that commend this new shock absorber to the automobile repairman that we would suggest that our readers write the manufacturers AUTO DEVICES CO., of 3212-14 Locust St., St. Louis, Mo., for complete information and their proposition to dealers.

Continued on Page 42.



Best Gasoline Brazing Forge
IN THE WORLD
Thousands sold in last ten years. Four sizes. Send for catalog.
The National Rubber & Specialties Co.
4433-39 Chickering Ave., Winton Place,
Cincinnati, Ohio.

The Perfect Power Hammer



The Simplest
in Construction
The Most
Effective in
Operation
The Most
Durable and
THE BEST

MADE IN TWO
SIZES:
3 inch square, 40 lb.
ram — shipping
weight, 1,100 lbs.
4 inch square, 80 lb.
ram — shipping
weight, 1,800 lbs.

Write any jobber
for Prices, or

MACGOWAN & FINIGAN
FOUNDRY & MACHINE CO.
204 North Third Street
ST. LOUIS, MO.



**DON'T FORGET
THIS FACT**

You will receive better pay for
your repair work when you use
STAR STEEL SHAPES

The "Triple Merit" Line — Soft Center,
Solid Cast, Crucible Steel.

Look For The STAR When You Order
Plowshares, Listershares, Moldboards, Plow
Points, Seeder Points, Cultivator Shovels, Land-
side Plates, Landside Points, Shovel Points
Drill Points, Subsoilers.

STAR MFG. COMPANY, Carpentersville, Ill.

**ACCESSORIES AND SUPPLIES OF
INTEREST TO THE TRADE.**

Continued from Page 41.

THE ILLUSTRATION BELOW is made from a photograph of the Pullford plowing and hauling attachment for Ford and other cars. The Pullford in itself is not a tractor, but consists of wheels, frame and gears necessary to transform the Ford's energy to power, instead of speed, the attachment supplements the Ford frame and takes power from the Ford differential through pinions keyed to Ford regular axle in place of the Ford rear wheels. This power in turn, is multiplied eleven to one for plowing and six to one for hauling through the gear reduction to the 36-inch Pullford drive wheels.

It shows just how to make all kinds of mechanical drawings in isometric perspective. It makes everything plain so that almost any mechanic can understand a sketch or drawing made in this way. The method is described as saving time in the drawing room and mistakes in the shop. It contains practical examination of the various examples of work.

The book also shows how to use the specially prepared isometric sketching paper and how quickly and how easily sketches of mechanical drawings can be made by using the ruled isometric paper. This book describes a system and method of sketching that should be particularly valuable for practical application in the smithing shop.

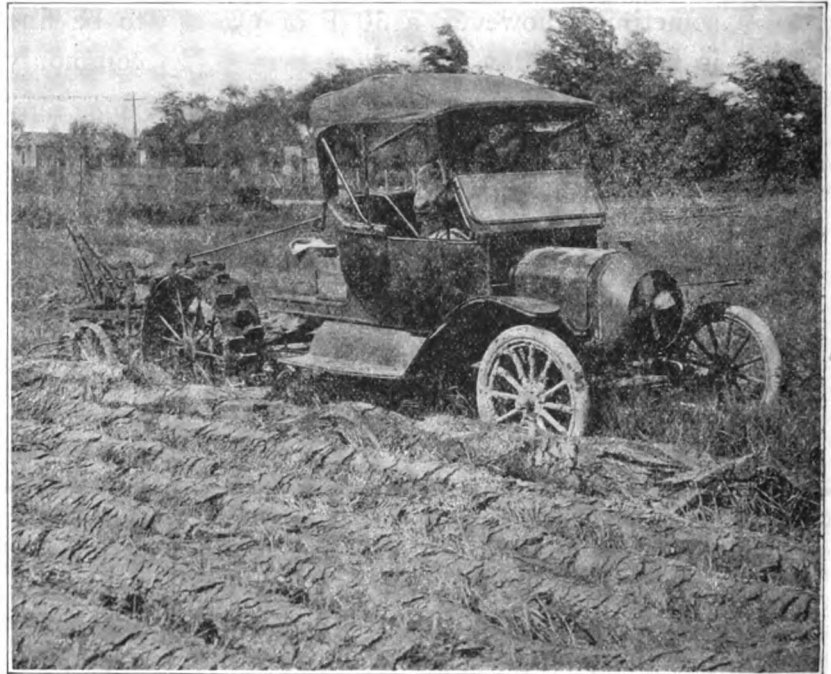

PULLFORD PLOWING AND HAULING

The Pullford frame is made of 3-inch steel "I" beams attached to Ford frame by clamps. The Pullford axle is made of 2-inch square steel, all parts are amply strong and durable for the work required.

No change or work on Ford frame is necessary, the clamps and "U" bolts hold the Pullford securely in place.

The Pullford shown above was plowing in July sun, in Illinois, temperature over 100 degrees, pulling a riding plow with two 12-inch shares 6 inches deep. It was equipped with an auxiliary fan and kerosene burner.

The Pullford will do hauling of all kinds, with the larger pinions, it will run along from five to six miles per hour with a load of six thousand pounds, over any ordinary roads. Lumber men have found it most efficient and valuable for their work.

The catalogue shows just how to make the Pullford plow haul loads and pull farm machinery of all kinds. It is mailed free. Address: The Pullford Company, P. O. Box A. B., Quincy, Illinois.

"Practical Perspective" by Richerds-Colvin, 64 pages, 5 by 8, limp cloth binding, price, 50c, Norman Henry Publishing Co., New York, N. Y.

This is the fourth edition of this practical treatise on the principles of perspective drawing and is so written that any mechanic can understand and apply them.

IMPORTANT NEW MOTOR BOOKS.

Laird & Lee, Inc., Chicago, announce that they have now in press the 1918-1919 edition of "The Modern Motor Car," by Harold P. Manly. It will be issued in one compact volume of 536 pages, large 12mo, with 225 illustrations from detail drawings and photographs and a 24-page alphabetical index, durably bound in flexible keratol, with round corners and colored edges. The revisions and additions bring this standard work up to the very minute making it a complete, practical and handy reference cyclopedia on all matters connected with the care, repair and upkeep of every type of automobile, old and new.

The same firm have also in hand for immediate publication: "The Farm Tractor—Its Care and Repair," by Wallace B. Blood. This will be uniform in style and size with "The Modern Motor Car," and at the same price, \$2.00, postpaid.

Another Book Increases in Price — We have received notice from the publishers that hereafter the price of Foden's Mechanical Tables will be 75 cents per copy instead of 50 cents as heretofore.

It is quite likely that other books will increase shortly and you will do well to get your order in early.

J O B W A N T E D !

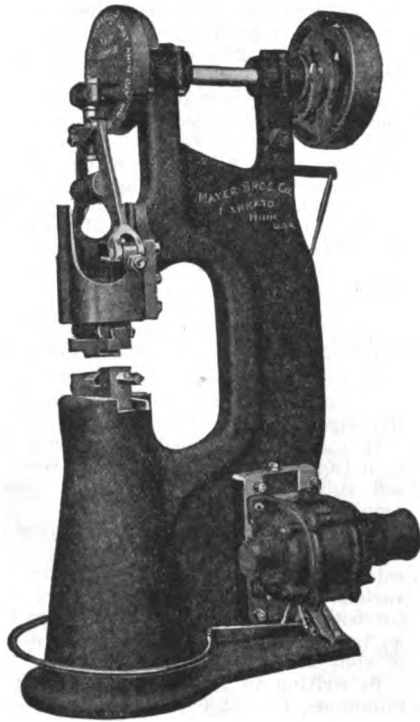

An able bodied workman seeks a position in some good blacksmith or machine shop. He is an old acquaintance and friend of the Editor of the American Blacksmith, to whom he is permitted to refer.

He is not particular as to what locality he works in, provided he has plenty of good hard work to do, and his employer is honest and careful.

With such a boss, he agrees never to touch intoxicants or indulge in other dissipation. He agrees to be on hand ready for work at seven o'clock in the morning, or any earlier hour the shop opens. He will work overtime without grumbling, even to twenty-four hours daily for as long a period as may be necessary.

He will agree never to strike, ask for higher wages, or even want to go fishing or take a holiday.

He will board himself and remain in perfect health indefinitely. He has no family cares to worry about. He and his brothers, older and younger, are of the well known L. G. P. HAMMER clan, world renowned for skill, integrity and ability.

He is willing to work for twenty cents a day and agrees to do more work than any six skilled men at \$3.00 per day. After his wages have been paid for twenty months, he agrees to work for nothing during the remainder of his natural life, which he estimates at fifty years.

He agrees to come on trial and after thirty days work, if his boss is not satisfied he will return home without any charge for his services.

He guarantees that he will relieve his employer from all drudgery, so he can spend more time with his family, and not be so eternally tired that he can get no enjoyment out of life.

He will treat all customers so pleasantly and do their work so skillfully that they will always bring their work to his shop, and advise their friends to do likewise.

He is not subject to enlistment or draft, and is ready to leave at once and begin work immediately on arrival.

Address: **LITTLE GIANT**, 101 Rock St., Mankato, Minn., U.S.A.



Here it is

The "Famous" Universal Woodworker

Just the machine you have been looking for to keep the dollars coming in.

All through the year when smithing or auto repairing drops off, woodworking stays on. If you have the outfit you'll reap the profits.

Do away with the several little machines and get a "Famous" which can handle all your work.

Easy payments. Write for catalog, prices and general information:

SIDNEY TOOL CO.

Dept. 14
Sidney, Ohio, U. S. A.

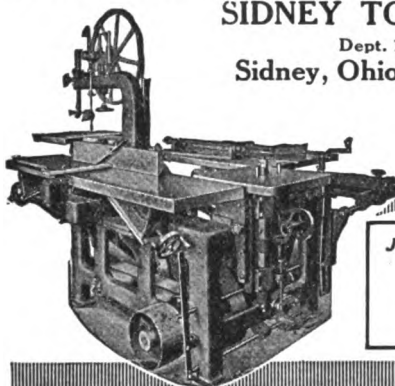

*Jointing, Babbitting
Grinding, Boring
Mitering, Sanding
Tenoning, Mortising
Dovetailing, Band
Sawing.*

PARK'S WAGON SHOP SPECIAL CIRCULAR RIP and CROSS-CUT SAW

22" Bandsaw, 6" Jointer

Tilting Guide, Rim Rounder, Felloe Borer, Spoke Tenoner,
All Ready for Instant Use

No Changing

Made in two sizes. Will be sent on trial anywhere in U. S. or Canada. Write for catalog today. Don't put it off.

Park's Ball Bearing Machine Company
4100 Fergus Cincinnati, O.

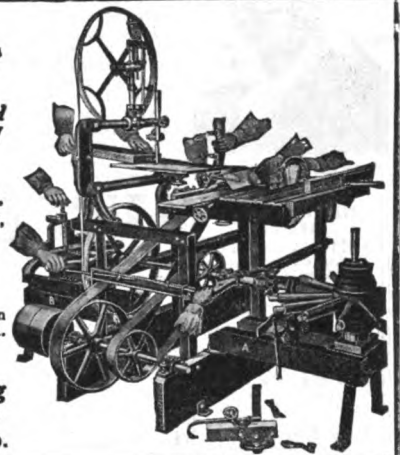

ROTO
The ELECTRIC BLOWER

only \$30.00

An electric blower that guarantees absolute satisfaction.

Will save you time now wasted blowing your forge by hand. With the ROTO you can do *twice* the work in *less* time—better, cheaper and quicker—and dependable at all times. Used by the United States Gov't BUY DIRECT FROM US AND ELIMINATE THE MIDDLEMAN'S PROFIT! Write NOW for free trial offer and our *Spec. al Cash Price of \$29.00.*

The Rosewater Electric Company
5516 Kinsman Road, Cleveland, Ohio

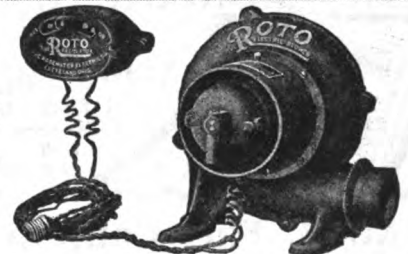

"MARVEL" Forge Blowers

This cut shows you the RING OIL BEARING design and construction of the motors used in our "ONE FIRE" \$35.00 MARVEL Blowers.

Note the large oil rings which revolve with the CASE HARDENED shaft, keeping it running in a perfect bath of oil on the bearings. Perfect Lubrication means long life.

Shipped on 30 days trial through your dealer.

Electric Blower Co.
Boston, Mass.

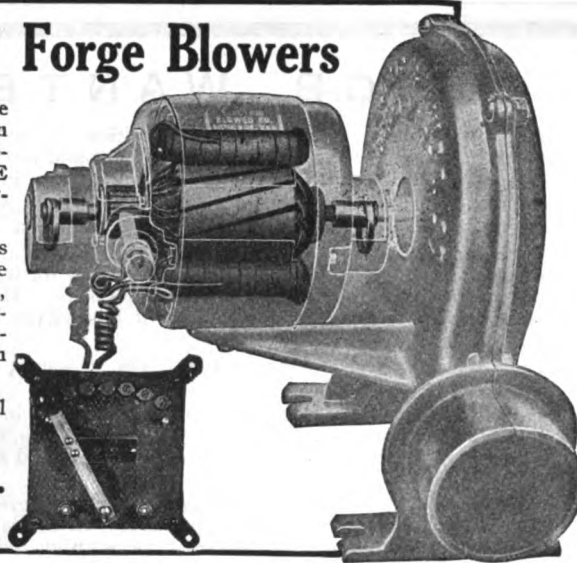

ACCESSORIES AND SUPPLIES OF INTEREST TO THE TRADE.

Continued from Page 42.

A NEAT FIT FOR EVERY SEAT

Good looks, economy and cleanliness are the prime requisites of automobile seat covers but to give continued satisfaction they must be easy to ride on.

The Gordon three piece seat covers with the "Sectional Overlap Lazy-back" manufactured by the J. P. Gordon Co., of Columbus Ohio fill all these requirements.

This new style Gordon insures a perfect fitting set of seat covers for any car—a misfit is impossible. They will not wrinkle. Besides perfect fitting Gordon covers insure better service because its "flexibility" permits each section of the cover to conform to the movement of upholstery without strain on any one part as with one piece covers, which either hold firm and destroy the effect of the upholstery springs or pull loose from the fastenings, rip the seams or tear the fabric.

If a spot is damaged by unusual wear or a bad stain the whole set of covers is not ruined. Only the damaged sections require to be replaced.

Auto repairmen and others interested in the Gordon line of seat covers should ask for their sample book showing the variety of fabrics in which they are made for both open and closed cars. You have no measuring or fitting to do—just send in your order.

In writing to the J. P. Gordon Co., of Columbus, Ohio they ask that you refer to this magazine.

Since the horse vehicle industry there is no branch of work that has been so remunerative as the automobile repairing trade.

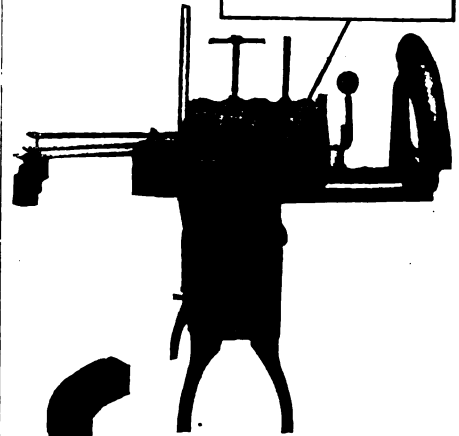
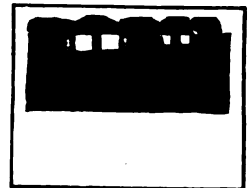

The Blacksmith Shop is the natural place to do auto repairing and the Blacksmith, the logical man to do the work. He is well established in the community and reliable. In his shop there is room without added expense to place the necessary equipment for repairs.

A tire repair outfit is probably about the first investment because there is such a demand for that work. Now that Spring is here the profits will increase by leaps and bounds and the Blacksmith that can do the work is the man to have the profits.

The Akron Rubber Mold & Machine Company of Akron, Ohio, manufacture the Tip-Top Line of Ti-Re-Pair Outfits. This concern is one of the largest manufac-

Continued on Page 45.

52 GOOD REASONS WHY YOU SHOULD OWN A WITTE HIGH GRADE ENGINE



Let Me Send You a WITTE Direct From Factory to Earn Its Own Cost—Prove Its Merit. Read My Latest Offer—Then Write for the Complete Story. It's Free, Postpaid

This is my 32d successful year in the engine business. Starting in a small shop with my first engine, built with my own hands, I now own and operate the largest exclusive engine factory in the world, selling direct to the user. The reason I have been successful is because I make a better engine at a better price—give prompt service—do as I agree. You can buy your WITTE Engine direct from my factory at a saving of \$15 to \$200—get it quicker—have economical, easy-to-use power at a fair price, just as others are doing. My first engines are still doing good service—you get the improvements I have made in 32 years, and I guarantee the engine you select for 5 years from date of purchase—long enough to earn its cost five times over.

HERE IS MY BEST ENGINE OFFER

I will sell you a WITTE Engine on Practically Your Own Terms—Cash—Payments— or No Money Down. 5-year Guarantee—Money Back If Not Satisfied on My New 90-Day Engine Offer. Write for my New Book Showing How WITTE High-Grade Engines Are Built—Why They Are Better—Why I Can Make You The Best Price. I want you to read this book whether you buy my engine or not.—ED. H. WITTE.

WITTE ENGINES

Standard Sizes—2, 3, 4, 6, 8, 12, 16, 22 and 30 H.P. Stationary, Portable and Saw-Rig Styles, to Operate on Kerosene, Gasoline, Distillate and Similar Fuels.

WITTE Engines have big surplus power. They are simply and strongly made, easy to understand, easy to operate. With a WITTE Engine on your farm, you can do your work easier, quicker and better—make more money. Hundreds and thousands of farmers and ranchers in every state are using WITTE Engines. They are making money—why not you? Try my engine, on its merits—not on the price. You can't get a better built engine for the price than I will sell you direct—all complete, tested and ready to run—no extras to buy—all the latest WITTE improvements—an engine that anyone can operate—built for practical, every-day hard work, durability and long life. The proof is a trial on your own work.

WRITE for my new, Free, copyrighted book, "How to Judge Engines". Learn why it pays to deal with an exclusive manufacturer direct—why I can give you the most engine value for your money, and the most liberal terms.—ED. H. WITTE, Pres.

Witte Engine Works

1769 Oakland Avenue,
Kansas City, Mo.
1769 Empire Bldg.,
Pittsburgh, Pa.

52 READ ALL OF THEM

- 1 Uses Fuel Only as Needed
- 2 Detachable Cylinder, Semi-Steel
- 3 No Wear, Vertical Valves
- 4 Large Open-Top Hopper
- 5 No-Leak Combustion Chamber
- 6 Automatic Fuel Mixer
- 7 Water-Cooled Valve Pocket
- 8 Non-Slip Fly-Wheel Hubs
- 9 Spark Plug Between Valves
- 10 Larger Water Space
- 11 Long Trunk Piston
- 12 Semi-Steel Piston Rings
- 13 Bronze Bushing on Piston Pin
- 14 Self-Lubricating Piston
- 15 Heavy I-Beam Connecting Rod
- 16 Flashed and Polished Cranks
- 17 Self-Timing Attachment
- 18 Noiseless Cut Steel Gears
- 19 Spark Advancer and Retarder
- 20 Fuel-Saving Governor
- 21 Oil and Gey Shields
- 22 Massive Bed Construction
- 23 Powerful Side Lever
- 24 Extra Wide Bearings
- 25 Automatic Fuel Valve Lock
- 26 Adjustable Air Damper
- 27 Use Pulleys on Either Side
- 28 Automatic Freshening of Fuel
- 29 Full-Length Bow
- 30 Water Drain from Hopper
- 31 Turned Fly Wheels
- 32 Greater Piston Push
- 33 Better Engine Design
- 34 Big Surplus H.P.
- 35 Standard Sizes
- 36 Easy Silent Running
- 37 Built by Experts
- 38 Guaranteed 5 Years
- 39 Adjustable Bearings
- 40 High-Grade Materials
- 41 High-Grade Finish
- 42 Easily Removable Piston
- 43 Semi-Steel Piston Pin
- 44 Automatic Ignition
- 45 Removable Valves
- 46 No Interior Packing
- 47 Battery or Magneto
- 48 Kerosene or Gasoline
- 49 Engine Ready to Run
- 50 Parts Easy to Get At
- 51 Simple in Construction
- 52 Easy Terms

"How to Judge Engines"

mailed FREE Postpaid. Get this valuable book. Mail coupon today.

MAIL This Coupon

This coupon (or a postal request) entitles you to my new 90-Day Engine Offer and Free Book, "How to Judge Engines." 1769

Name.....

Town..... State.....

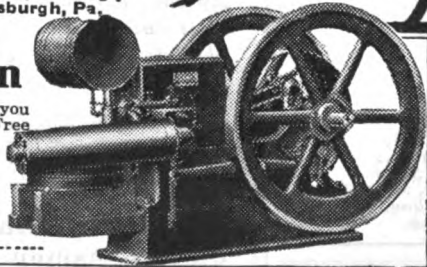

The Oldest Established Welders in the Country

Manufacturers of high-grade welding apparatus, welding materials and flux since 1908.

The only firm that can weld aluminum crank cases and cylinders without warping or pre-heating. All work guaranteed absolutely against warping.

Cylinder-grinding, gear-cutting and case-hardening a specialty. Write for our new circular.

AMERICAN WELDING CO.
H. G. DONIGAN, Mgr.
23rd & Olive Sts., ST. LOUIS, MO.

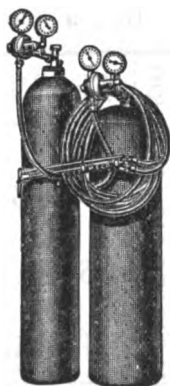

Don't Send a Penny

These Len-Mort Work and Outdoor Shoes are such wonderful value that we will gladly send them to you prepaid, no money down. You will find them so well made and so stylish and such a big money saving bargain that you will surely keep them. No need to pay higher prices when you can buy direct from us. Why pay \$5 and \$6 for shoes not near so good?

Great Shoe Offer

This shoe is built to meet the demand of an outdoor city worker's shoe as well as for the modern farmer. Built on stylish lace Blucher last. Special tanning process makes the leather proof against the acid in milk, manure, soil, gasoline, etc. Made by a special process which leaves all the "life" in the leather and gives it wonderful wear-resisting quality.



Very flexible, soft and easy on the feet. They outwear three ordinary pairs of shoes. Double leather soles and heels. Dirt and water-proof tongue. Heavy chrome leather tops. Just slip them on and see if they are not the most comfortable, easiest shoes you ever wore.

Pay \$3.85 on arrival. If after careful examination you don't find them all you expect, send them back and we will return your money. Send your name and address, and be sure to state size you want. Send no money. Price only \$3.85 on arrival. We send these splendid shoes PREPAID. You are to be the judge of quality, style and value. Keep them only if satisfactory in every way. Be sure to give size wanted. Send now.

LEONARD-MORTON & CO., Dept. 1207 CHICAGO

Dealers! Garagemen!
Put in a complete, assorted stock of **VULCAN SPRINGS**

Link up Spring Service for Your Customers with our "Spring Service for the Nation". Write now for our special proposition of assorted stock of quick sellers, with Display Rack, Doorsign, Window Transfers, etc.—Free.

Jenkins Vulcan Spring Co.,
Richmond, Indiana.

Stock Carried at These Branches:

- St. Louis, Mo. 1402 Chestnut St.
- Minneapolis, Minn. 1024 Hennepin Ave.
- Dallas, Texas 209 So. Houston St.
- Reading, Pa. 538 Franklin St.
- Sumter, S. C. 29 Caldwell St.
- Atlanta, Ga. 43 Auburn Ave.



If you have never learned by actual experience just how good **Pioneer Shaft Ends** are, do it now by ordering a few of your jobber, and don't let him pawn off on you the "just-as-good," "may suit" brand. Look for the Pioneer trade-mark on the wrappers. Possibly you order a certain kind of horse nails and shoes because they are better and please. So why not specify **Pioneer Shaft Ends** for the same reason? Once you get acquainted, they will be your affinity ever afterwards.

Pioneer Shaft Ends are the kind that are easy to fit, and make the strongest joint.

THREE SIZES:—BUGGY, SURREY AND LIGHT BUGGY.

Made by **CRANDAL, STONE & COMPANY, BINGHAMTON, N. Y.**

ACCESSORIES AND SUPPLIES OF INTEREST TO THE TRADE.

Continued from Page 44.

turers of Tire-Builders' Equipment in the world, and their equipment is being used by more than 75% of the rubber tire makers in the country, because they meet requirements.

Elsewhere in this issue there will be found the full particulars of this particular line. In addition to this outfit, the Akron Rubber Mold & Machine Company manufacture a complete line of tire repair equipment covering various requirements of service, at a lower price.

The Company publishes a booklet containing a great deal of interesting information on the tire repair business and its opportunities for profit, as well as complete specifications and illustrations of the

New-Type-F Equipment. A copy of this booklet will be sent free upon request to the General Offices, No. 939 Sweitzer Avenue, Akron, Ohio. Please mention the American Blacksmith, Auto and Tractor Shop.

BUREAU OF MINES FREE BULLETINS

Bulletin 145. Measuring the temperature of gases in boiler settings, by Henry Kreisinger and J. F. Barkley. 1918. 72 pp., 31 figs.

Bulletin 151. Recovery of gasoline from natural gas by compression and refrigeration, by W. P. Dykema. 1918. 123 pp., 15 pls., 15 figs.

Bulletin 164. Abstracts of current decisions on mines and mining, reported from September to December, 1917, by J. W. Thompson. 1918. 147pp.

TECHNICAL PAPERS.

Technical Paper 187. Slag viscosity

tables for blast-furnace work, by A. L. Feild and P. H. Royster. 1918. 38pp., 1 fig.

Technical Paper 193. Quarry accidents in the United States during the calendar year 1916, by A. H. Fay. 1918. 58 pp.

OTHER PUBLICATIONS.

Coal-Mine Fatalities, 1917, by A. H. Fay. 1918. 37pp.

Resuscitation Chart, by Yandell Henderson. 1918. A poster, 11 by 16 inches.

Mine Gas Chart, by G. A. Burrell. 1918. A poster, 26 by 36 inches.

Note.—Only limited supply of these publications is available for free distribution and applicants are asked to cooperate in insuring on equitable distribution by selecting publications that are of especial interest. Request for all papers can not be granted. Publications should be ordered by number and title. Applications should be addressed to the Director of the Bureau of Mines, Washington, D. C.

Sweet's Toe Calks

**Best for Your
Customers
Best for Your
Business**

Every customer of yours who has his horses shod with Sweet's Toe Calks comes back to you when calks need attention. He does not try to renew or fix them himself. And this is as it should be for by the time the calks need attention the hoof will need attention and the proper kind of attention can only be obtained from an experienced shoer.

By using and recommending Sweet's Toe Calks you not only create repeat business but you give your customers a calk that assures the utmost in satisfaction. Sweet's Welded Toe Calks when welded to the shoe form an integral part of it. They can not come off and cause damage and injury; they extend clear across the toe and give the horse a better, broader, firmer grip and they are unequalled for long wear.

Though open hearth steel is scarce and high we are still using it rather than lower the high standard of Sweet's Welded Toe Calks.

Use and recommend them because it is to your best interest to do so.

FRANKLIN STEEL WORKS

Joliet, Ill., Cambridge, Mass., Hamilton, Ont.

No. 3

He's a Poor Smith That's Afraid of Sparks

The Rochester Helve Hammer

**6
SIZES
2
STYLES
OF
FRAMES**

The ROCHESTER HELVE HAMMER is strongly made of first class material throughout. First grade hickory helve; exceptionally heavy anvil, giving greatest resistance to blow struck; steel base; long bearings for helve pivot. Fine for welding tires, work which cannot be done under most upright hammers. Dies can be furnished either lengthways or crossways of helve without additional cost, if specified with order.

Send for our illustrated catalog free

**See left-hand margin
note**

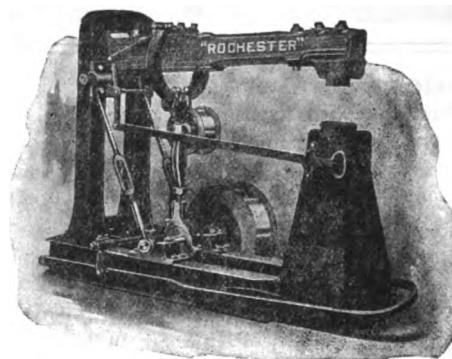

THE "ROCHESTER" HELVE HAMMER

DON'T PUT OFF BUYING THAT WHICH YOU CAN BUY TODAY

HELVE HAMMERS—TIRE SETTERS—SHELL BANDING MACHINES

The WEST TIRE SETTER CO.

ROCHESTER, NEW YORK

Good Books for the Craft

The following selected titles are the best books to be obtained on their respective subjects. The American Blacksmith, Auto and Tractor Shop will gladly supply you, postpaid, with any of the following, cash with order. We can also get for you and book desired.

Craft Books

| | |
|--|--------|
| Steel, Its Selection, Annealing, Hardening and Tempering..... (Markham) | \$2.50 |
| The Blacksmith's Guide..... (Slalows) | 1.50 |
| Tool Making..... (Markham) | 1.50 |
| Foundry Work..... (Stimpson) | 1.00 |
| Drop Forging, Die Sinking and Machine Forming of Steel..... (Woodworth) | 2.50 |

Horseshoeing

| | |
|---|------|
| Rich's New Artistic Horseshoe- ing..... (Rich) | 1.00 |
| Textbook of Horseshoeing..... (Lungwitz) | 2.25 |
| Art of Horseshoeing..... (Hunting) | 1.25 |

Gas Engines

| | |
|------------------------------------|------|
| The Modern Gas Tractor..... (Page) | 2.00 |
|------------------------------------|------|

Oxy-Acetylene Work

| | |
|--|------|
| Oxy-Acetylene Welding and Cutting..... (Willis) | .50 |
| Oxy-Acetylene Welding and Cutting..... (Manly) | 1.00 |

| | |
|--|------|
| Oxy-Acetylene Flame..... (Dunham) | 1.00 |
| Forge Practice..... (Bacon) | 1.50 |
| Forging..... (Jernberg) | 1.00 |
| Hand Forging and Wrought..... (Googerty) | 1.00 |
| Iron Ornamental Work..... | |
| Plain and Ornamental Forging.... (Schwarzkopf) | 1.50 |

Automobiles

| | |
|---|------|
| Automobile Repairing Made Easy..... (Page) | 3.00 |
| Modern Starting, Lighting and Ignition System..... (Page) | 1.50 |
| Storage Batteries Simplified..... (Page) | 1.50 |
| The Modern Gasoline Auto- mobile (new edition 1918)..... (Page) | 3.00 |
| Questions and Answers Relat- ing to Modern Automobiles..... (Page) | 1.50 |
| The Model T. Ford Car..... (Page) | 1.00 |
| Dyke's Automobile and Gas- oline Engine Encyclopedia (new 1918 edition)..... (Dyke) | 3.50 |

The American Blacksmith, Auto and Tractor Shop
BOOK DEPARTMENT

When You Order Shoes or Calks

REMEMBER

PHOENIX

Horse and Mule Shoes

and

BULL DOG

TOE CALKS

**Are the Best. Try
them the next time
you are ordering
and you will see why.**

"NEW EASY" 4 Sizes BOLT CLIPPERS "EASY" 2 Sizes

THE GENUINE TOOL



KNOWN AND PREFERRED EVERYWHERE

H. K. PORTER EVERETT, MASS. U. S. A.

EMPIRE STEEL WHEELS

Plain or grooved Tire To Fit Any Wagon

Farm Trucks

All Standard Types

Write today for Proposition to Blacksmiths.

Empire Mfg. Co.
P. O. Box 308
QUINCY, ILLINOIS



The Woodworkers Friend

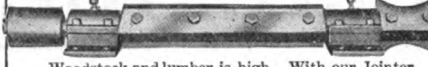

Woodstock and lumber is high. With our Jointer Heads you can buy rough lumber of any kind and dress it to suit the job. Saves time, money and lumber. Would this be any object to you? If so, get our circulars and prices. Sold on 30 day trial.

Mfg. by WHISLER MFG. CO., Gibson, Iowa

CLEAN YOUR ENGINE REGULARLY WITH A



Wagner Auto Engine Cleaner

One qt. kerosene and 6 lbs. air pressure cleans all dirt, grit and grease from engine. Prevents wear, actually saves half the usual repairs. Quick, economical, thorough, easy and cleanly to operate. Necessity for repair shops.

Wagner Specialty Co., 1902 Broadway, New York City

Vulcanizers

YOUR FINAL VERDICT

MILLER'S or ANDERSON for every use.

80 - Page Catalog free on request.

Free Instructions.

Extra Ply Tires

Exclusive Territory Given.

Write, yours may be open.

Address Dept B
CHAS. E. MILLER,
Anderson, Indiana.
1894 U. S. A.

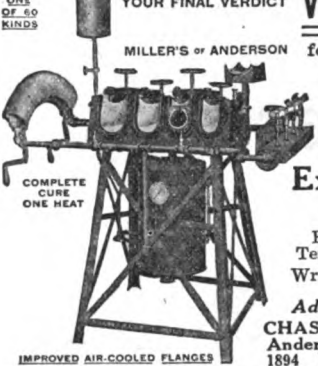

THE IMPROVED EASY HOOF TRIMMER

Will cut a hoof easier, quicker and better than any tool you have ever had. Weight 21-2 pounds, opening 2 inches, cuts one inch. Thousands of shoers are using the EASY HOOF TRIMMER with great satisfaction.

SEND \$1.50 TODAY

Delivered to any part of the U. S. by Parcel Post.

MUNCIE WHEEL CO., Muncie, Ind., U.S.A.



BALL AND ROLLER BEARINGS

All Types—IN STOCK—Many Sizes

THE GWILLIAM COMPANY

ENGINEERS

253 W. 58th St. (at Broadway) NEW YORK
Branch: 1314 Arch St., Philadelphia



HAVANA STEEL WHEELS

For your Farm Wagon, so as to make it a Low-Down, instead of having to do your work over the sides of a high wheeled wagon. No dry, loose wheels. More and easier work done.

Send postal for free catalog of Steel Wheels and Farm Trucks.

HAVANA METAL WHEEL CO.,
Box 85 Havana, Ill.



ACCESSORIES AND SUPPLIES OF INTEREST TO THE TRADE.

ALFORD AUXILIARY SPRING

Tires are getting higher priced every day and no one is any better aware of the fact than the man who drives a car and buys its "shoes".

The Alford Auxiliary Spring, manufactured by the Andrew Hoffman Mfg Co., 5034 South State St., Chicago Ill. will enable the car owner to get 50 per cent more tire mileage from his Ford than would be otherwise possible.

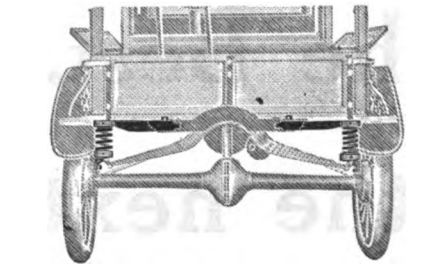

The car will ride 50 per cent easier empty or loaded. When the car is empty you ride on the Alford springs and when it is loaded you compress the springs so that you ride on three springs together.

All weight is carried on the frame and springs and none on the body of the car. They will prevent the swinging and tipping of the body from side to side which often causes them to tip over and other damage.

This spring system is mechanically per-

fect and fully guaranteed and money will be refunded upon return of attachment at the end of 30 days trial if they aren't all that is claimed for them.

The Alford Auxiliary Spring Attachment will permit you to make a 3/4 to one ton truck out of a Ford car in 30 minutes at a cost of \$16 and every user is a salesman for you.

Agents are wanted everywhere by the Andrew Hoffman Mfg. Co., S. State St., Chicago, Ill., and they will appreciate having you write to them for their discounts etc., and addressing Dept. 2.

PREST-O-GRIP CHAINS.

On every hand you see the enormously growing use of motor trucks. Motor trucks are rapidly becoming a big factor in hauling and even in long distance transportation.

You can make money by recognizing this condition because you know that a motor truck must have chains for bad going and for safe driving.

In this connection it will be to your advantage to take the matter up with the well known Rowe Company, of Plantsville, Conn., who will be pleased to give you full particulars concerning their Prest-O-Grip Anti Skid Chains.

Veterinary Post Mortem Technic, by Walter J. Crocker, B. S., V. M. D., Professor of veterinary pathology, School of Veterinary Medicine, University of Pennsylvania. With 142 illustrations. \$4 net.

This book has been written in an endeavor to fill a gap in the American veterinary literature which was keenly felt by the author in teaching post mortem pathology. It is with the earnest hope that it may help those who do make post mortem examinations and encourage those who should but do not perform autopsies.

It pertains only to the mechanics of post mortem examinations presenting a few instruments and rules for cutting, and describing tissues which are indispensable to the operator in adequately exposing the various anatomical parts for the study of the relationship of the organs and pathological lesions demanded in careful post mortem examinations.

The illustrations of technical methods in the text were prepared from the original photographs of fresh specimens instead of line drawings. Good photographs more forcibly portray to the student mind the reality of the subject, and establish a closer personal association with the actual work. The contents include general considerations, autopsy room, post mortem instruments, external examinations, internal examination of the horse, ruminants, swine, dogs and cats, mice, guinea pigs, rabbits, fowls and elephant; technic and description of the organs, post mortem protocol and report; appendix.

Principles, Operation and Products of The Blast Furnace—J. E. Johnson, Jr., 538 pages, Price \$5. Fully illustrated.

An interesting and valuable addition to the books on blast furnace construction and operation that should be of much interest to those interested in the manufacture of iron products.

EWALD'S TIRE RETREADER.

Ready for the junk man old tires are worth about 25 cents each—by retreading by the Ewald process from one to three thousand miles can be gotten out of them before they are in shape to go their final rest in the junk pile.

By means of the Ewald Tire Retreader
(Continued on page 42)

More Men Are Now Driving Their Own Cars Than Ever Before

The war has done it. And these driver-owners, men and women, many of whom would ordinarily depend on their service stations, even for minor repairs, find themselves up against the universal short-handedness. Consequently, more and more of them turn to the

1919 EDITION OF THE MODERN MOTOR CAR

By HAROLD P. MANLY

"The Bible of Simplified Upkeep"

That's because they find in it everything they can possibly want to know about their car "in sickness or in health." *Motor World* says: "The most illuminating and instructive work of its kind. . . . Indispensable to novice and expert." Care, repair and upkeep for every type, old and new. Shop and roadside methods of trouble location and remedy. All latest and best ideas. Detailed instructions for 36 models of carburetors.

Flexible Keratol; round corners; 538 pp.; 225 illustrations; 5x7 1/2 inches. **\$2.00**

NEWEST AND BEST FOR OWNER, DRIVER, REPAIRMAN AND SALESMAN

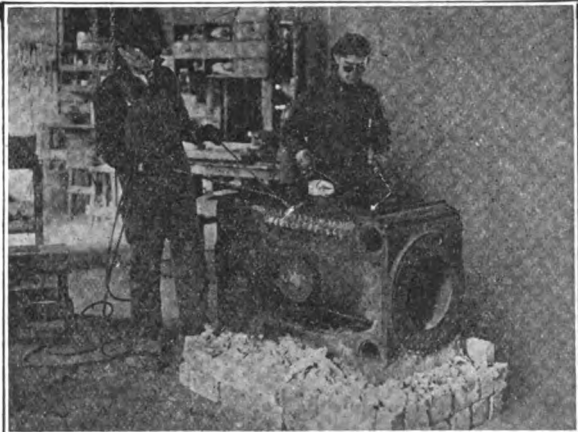

“SAVE THE PIECES!”

“All the King’s horses and all the King’s men couldn’t put Humpty-Dumpty together again.”

It’s a “One-man” job to restore broken or cracked metal parts to their original value and usefulness with Economy Welding and Cutting Outfits and Economy Acetylene Gas Generators

MAKE YOUR OWN ACETYLENE

Using the Economy Acetylene Gas Generator you can make your own acetylene gas; make more of it, for less money, and with no freight or hauling charges.

UNCLE SAM needs the acetone in compressed acetylene—needs it bad—needs all he can get. Economy Acetylene Gas Generators do not require acetone.

Write for prices and catalogues to

Economy Welding Machine Company
213 Southwest Boulevard, KANSAS CITY, MO.
Manufacturers of Welder’s supplies and equipment of all kinds.

OUR FALL 1918 CATALOGUE IS READY

Get our new prices on Wheels, Spokes, Rims, Axles, Carriage and Wagon Hardware of all kinds, Steel and Iron Tires, Rubber Tires, Shafts, Plow Handles etc.

A. Wheel Top & Hardware Co.

129 E. 8th St. Cincinnati, Ohio

We Tear ’em up and Sell the Pieces

We save you 50 to 75 per cent on auto repairs. Can supply most any part needed.

Our Guarantee—If not satisfactory, can be returned, and money refunded.

Auto Wrecking Co.

13th and Oak Sts., KANSAS CITY, MO.

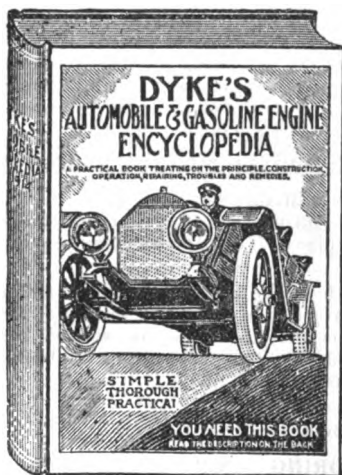

Everything You Want to Know About an Auto
Dyke’s Automobile Encyclopedia

1918 (Seventh) Edition

\$3.50 Postpaid

Entirely re-written; hundreds of new illustrations; many new subjects added. Practically a NEW book. Larger and better than ever. The most complete automobile reference book in the world today.

- ASSEMBLY OF CAR**
138 illustrations—51 pages.
- ENGINES**
291 illustrations—89 pages.
- IGNITION, COIL & BATTERY**
189 illustrations—50 pages.
- ELECTRIC SYSTEM**
238 illustrations—118 pages.

- OPERATION, CARE, ETC.**
159 illustrations—36 pages.
- TABLES, SPECIFICATIONS, ETC.**
15 pages.
- TROUBLES & REMEDIES**
16 pages.
- TRUCKS, TRACTORS, ETC.**
103 illustrations—20 pages.
- CARBURETION**
119 illustrations—44 pages.
- COOLING & LUBRICATION**
81 illustrations—21 pagef.

- IGNITION—MAGNETOS**
186 illustrations—65 pages.
- STORAGE BATTERIES**
162 illustrations—46 pages.
- LICENSE LAWS & SALESMANSHIP**
13 pages.
- TIRES**
180 illustrations—27 pages.
- REPAIR SUBJECTS**
1189 illustrations—154 pages.
- SUPPLEMENTS**
332 illustrations—01 pages.

Each and every subject is complete. There are many subheadings not mentioned here and every subject fully illustrated and simplified. Every conceivable automobile question is discussed and repairs are illustrated and made so simple that auto repairing is made as easy as “rolling off a log.”

Whether you are now doing auto repairing or not you need this book. If you aren’t doing auto repairing now you will be one of these days. Price \$3.50 postpaid to your address. Send your check, stamps or money order to

American Blacksmith, Auto & Tractor Shop
Buffalo, N. Y.



Best Gasoline Brazing Forge
IN THE WORLD
Thousands sold in last ten years. Four sizes. Send for catalog.
The National Rubber & Specialties Co.
4433-39 Chickering Ave., Winton Place, Cincinnati, Ohio.

The Perfect Power Hammer

The Simplest in Construction
The Most Effective in Operation
The Most Durable and

THE BEST

MADE IN TWO SIZES:

3 inch square, 40 lb. ram — shipping weight, 1,100 lbs.
4 inch square, 80 lb. ram — shipping weight, 1,800 lbs.

Write any jobber for Prices, or

MACGOWAN & FINIGAN
FOUNDRY & MACHINE CO.
204 North Third Street
ST. LOUIS, MO.



DON'T FORGET THIS FACT

You will receive better pay for your repair work when you use **STAR STEEL SHAPES**

The "Triple Merit" Line — Soft Center, Solid Cast, Crucible Steel.

Look For The STAR When You Order Plowshares, Listershares, Mollboards, Plow Points, Seeder Points, Cultivator Shovels, Land-side Plates, Landside Points, Shovel Points Drill Points, Subsoilers.

STAR MFG. COMPANY, Carpentersville, Ill.

ACCESSORIES AND SUPPLIES OF INTEREST TO THE TRADE.

(Continued from page 40)

it is possible to take two old tires and by stapling the treads together obtain a tire that will render satisfactory service for thousands of miles.



The Romort Mfg. Co., of Oakfield, Wisconsin positively guarantee that the staples will not pull out when properly set, that the staples will outwear the tire, that the staples will not chafe the inner tube if the strip fabric is used over the staples; that two old tires stapled together by their process are almost worth a new one.

In addition to its primary use as a Retreading machine the machine can be used for a great variety of other purposes such as patching up harness, and belts.

The complete outfit sells for \$15 and consists of one Ewald Tire Retreader, one box of 250 1/2 inch staples, 250 5/8 inch staples, full directions for use, can of reliner cement, two rolls of liners and hinged hardwood box in which the outfit is packed.

One user of this machine states that he retreaded 10 tires in one day at \$2.50 each and more than paid its cost the first day.

Write to the Romort Mfg. Co., Dept. A. B. at Oakfield, Wis. or to your jobber, for circular describing this practical and simple money making outfit.

MORE BUSINESS THAN USUAL.

Every automobile you work on will bring you more business if you have the "Gordon" Sample Book and show your customers the desirability of the Gordon Seat Covers and Top Re-Coverings.

Gordon Covers are quick sellers. They are easy to put on and they net you a good profit. The sample book and price list are all you need—no stock to carry—no measuring and no fitting. Shipments are made in three days and perfect fitting patterns for more than a thousand models of cars are in stock.

If people cannot get new cars, help them renew the upholstery of their old ones—help them get a top covering to make the old top as good as new.

Gordon seat covers, top re-coverings, tire covers and other fabric equipment are in greater demand this season than ever before. You should get this business as a part of your overhauling and repair service. Write for our Proposition today to the J. P. Gordon Co., 325 North Fourth Street, Columbus, Ohio, and mentioning this magazine.

Aviation Engines—Their Design, Construction, Operation and Repair, by Lieut. Victor W. Page, Aviation Section, S. C. U. S. R. 576 Octavo Pages. 253 Specially Made Engravings. Price, \$3.00 net.

The rapidly increasing interest in the study of aviation, and especially of the highly developed internal combustion engines that make mechanical flight possible, has created a demand for a textbook suitable for schools and home study that will clearly and concisely explain the workings of the various aircraft engines of foreign and domestic manufacture.

This treatise, written by a recognized authority on all the practical aspects of internal combustion engines and airplanes fills the need as no other book does. The matter is arranged in a logical manner; all descriptive matter is simply expressed and copiously illustrated so that anyone can understand airplane engine operation and repair even if without previous mechanical training. This work is invaluable for anyone desiring to become an aviator or aviation mechanic.

The latest rotary types, such as the Gnome Monosoupape and LeRhône, are fully explained, as well as the recently developed Vee and radial types. The subjects of carburetion, ignition, cooling and lubrication also are covered in a thorough manner. The chapters on repair and maintenance are distinctive and found in no other book on the subject.

Invaluable to the student, mechanic and soldier wishing to enter the aviation service because it gives practical installation and repair instructions. Not a technical book but a practical, easily understood work of reference for all interested in aeronautical science.

AKRON-WILLIAMS TUBE DEFLATOR

The Williams Foundry & Machine Company, Akron, Ohio, have just brought out an improved Tube Deflator, for repair shop use.

With it the tube is slipped over one of the projections on plate; then by turning the handle the tube is wound tightly around the two projections and the air exhausted in a jiffy.

It is a handy size and will deflate any size tube.

MOTORING PUBLIC TURNING TO BLACKSMITH FOR DEPENDABLE REPAIR WORK

The growth of the automobile business has meant the advent of days of greater prosperity than was ever before known to many a blacksmith, who has taken advantage of his opportunities.

Just consider the garages with a troubleman or two and the repair shops that have sprung up in your neighborhood with in the past few years. Right under the noses of men who are masters in the art of repair making, new businesses founded on the motor trade have been built up and are flourishing.

The blacksmith who has seen his chances and made a bid for this business has in a majority of cases met with gratifying success.

(Continued on page 45)

SHAFT

If you have never learned by actual experience just how good **Pioneer Shaft Ends** are, do it now by ordering a few of your jobber, and don't let him pawn off on you the "just-as-good," "may suit" brand. Look for the Pioneer trade-mark on the wrappers. Possibly you order a certain kind of horse nails and shoes because they are better and please. So why not specify **Pioneer Shaft Ends** for the same reason? Once you get acquainted, they will be your affinity ever afterwards.

Pioneer Shaft Ends are the kind that are easy to fit, and make the strongest joint.

THREE SIZES:—BUGGY, SURREY AND LIGHT BUGGY.

Made by CRANDAL, STONE & COMPANY, BINGHAMTON, N. Y.

"GET-A-WITTE"

**BUY
ON YOUR
OWN
TERMS**

KEROSENE ENGINE
DIRECT FROM FACTORY—FACTORY PRICES.

Own your farm or shop power at lowest cost. Get as much power for half the price, using kerosene. Choose your own terms—Cash, Payments, or No Money Down as arranged for. Save \$15 to \$200 buying direct—all fully explained in my new book—sent FREE on request.—Ed. H. Witte, Pres.

WITTE Engines
Stationary—Portable—Saw-Rig



are all made in the largest exclusive engine factory in the world dealing direct with user. My Free Factory Book, "How To Judge Engines", tells the whole story—tells why I can make a better engine and sell it for less. No need to pay higher prices than I ask to get the kind of an engine you want, or accept an "old style" or "back-number" to save money. Write for my new illustrated factory book and see just what a big offer I am able to make.

Witte Engine Works
1762 Oakland Ave. Kansas City, Mo.
1762 Empire Bldg. Pittsburgh, Pa.



doing more business on the one spring that is sold for more replacements than all other springs put together—the Tuthill Titanic Spring.

This spring gets away entirely from center breakage, the cause of seventy-five per cent of the trouble in spring breakage. It is reinforced at the center instead of weakened.

The Tuthill Spring Co. offer very satisfactory service on spring shipments, maintaining stocks in all parts of the country, and shipping special orders from their factory in Chicago, within two or three days of their receipt.

Do Not Accept Imitations

When you ask for an article you have seen advertised in The American Blacksmith, see that you get it. Don't let your dealer sell you something which he calls "just as good." Don't let a traveling man talk you into buying an inferior make. The goods advertised in these columns are made by firms whose reliability we guarantee. You run no risk whatever in buying these goods. Refuse imitations.

Insist upon getting what you ask for

"MARVEL" Forge Blowers

This cut shows you the RING OIL BEARING design and construction of the motors used in our "ONE FIRE" \$38.00 MARVEL Blowers.

Note the large oil rings which revolve with the CASE HARDENED shaft, keeping it running in a perfect bath of oil on the bearings. Perfect Lubrication means long life.

Shipped on 30 days trial through your dealer.

Electric Blower Co.
Boston, Mass.

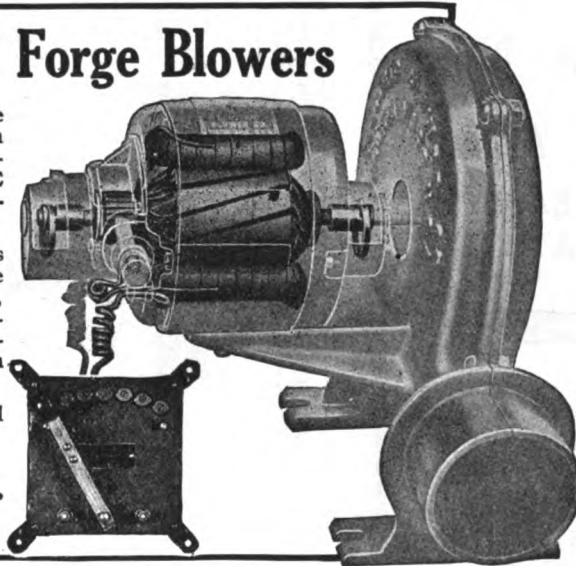

ACCESSORIES AND SUPPLIES OF INTEREST TO THE TRADE.

(Continued from page 42)

The firm that has been in business for a number of years has a standing. When that firm takes up the sale of automobile

accessories, the motorist at once sees the advantage of buying his accessories and repairs from a dealer of established reputation.

Automobile Springs is an item on which a large business is being done by blacksmiths every where. Naturally they are

FODEN'S MECHANICAL TABLES

SAVE ALL FIGURING!

Tell at a glance how much stock to use for oval or elliptical hoops of any size, the circumferences of circles, weight of flat, square and round stock, and the weight and strength of ropes and chains.

Should be in every progressive Smith's hands. Bound very neatly in green cloth. Price, 75c.
AMERICAN BLACKSMITH, AUTO & TRACTOR SHOP
Buffalo, New York

SUNDERMAN **\$7.50** f. o. b. Newburgh
Vacuum Carburetor
For Ford, Metz and Saxon Four.

Saves from 30 to 50% of Gasoline in ANY Motor.

That's a positive statement that you can prove easily for yourself by sending us an order by return mail. Hundreds of car owners are doubling their mileage with the Sunderman Carburetor—they tell us about it in every mail. Gives much more power and greater flexibility at the same time.

Fine Dealers' Proposition—Write for it NOW.

SUNDERMAN CORPORATION
 42 Chambers Street, Newburgh, N. Y.
 Pacific Coast Branch: 593 Market Street San Francisco, Cal

20th CENTURY Quick-Repair Kit
 Contains sheet self-vulcanizing rubber patch, tube special 20th Century Cement and sandpaper.

*Just the thing for motorists!
 — a big seller — a fast seller.*

20th Century Patches are GUARANTEED. When properly applied they will not leak, loosen, creep or blow out.

Order through your jobber or write direct.

20th CENTURY TIRE PROTECTOR CO.
 MIDLOTHIAN, TEXAS
Manufacturers of the famous 20th Century Self-vulcanizing fabric-back Patch.



Let the **WILLIS WELDER** Do Your Work



With this oxy-acetylene worker you can cinch trade in your neighborhood that your competitor cannot get.

More Work, better Results, more satisfied customers, **More Money.** Does that sound good to you?

Get our catalog and let us prove some of the results of proper welding. If your Dealer cannot supply you, we can. Write direct.

HENDERSON-WILLIS
 Welding & Cutting Company
 11th and North Market Streets
 ST. LOUIS, MISSOURI, U. S. A.

PARK'S WAGON SHOP SPECIAL
CIRCULAR RIP and CROSS-CUT SAW

22" Bandsaw, 6" Jointer
 Tilting Guide, Rim Rounder, Felloe Borer, Spoke Tenoner,
All Ready for Instant Use
No Changing

Made in two sizes. Will be sent on trial anywhere in U. S. or Canada. Write for catalog today. Don't put it off.

Park's Ball Bearing Machine Company
 4100 Fergus Cincinnati, O.

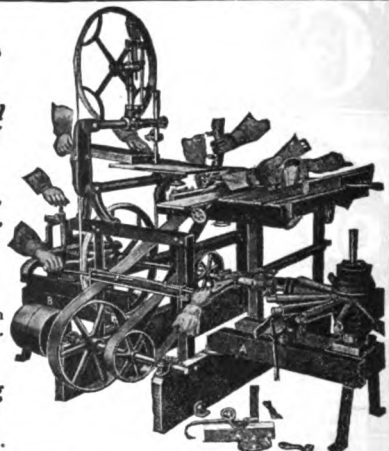

NW

Northwestern Horse Nails

Are the Best All Around FOR STRENGTH, SAFETY and QUALITY OF MATERIAL



The most perfect in form and finish. Made of the highest grade material to our own analysis. Will hold a shoe longer than any other nail made. Has a reenforced point—making it easiest to drive and the safest to use.

Union Horse Nail Co., Chicago, Ill.

He's a Poor Smith That's Afraid of Sparks

The Rochester Helve Hammer

6 SIZES
2 STYLES OF FRAMES

The **ROCHESTER HELVE HAMMER** is strongly made of first class material throughout. First grade hickory helve; exceptionally heavy anvil, giving greatest resistance to blow struck; steel base; long bearings for helve pivot. Fine for welding tires, work which cannot be done under most upright hammers. Dies can be furnished either lengthways or crossways of helve without additional cost, if specified with order.

Send for our illustrated catalog free
See left-hand margin note



THE "ROCHESTER" HELVE HAMMER

The WEST TIRE SETTER CO.
 ROCHESTER, NEW YORK

DONT PUT OFF BUYING THAT WHICH YOU CAN BUY TODAY

HELVE HAMMERS—TIRE SETTERS—SHELL BANDING MACHINES

Are You a User of
PHOENIX

Horse and Mule Shoes?
If not, it will pay you
to try them and see
how much better they
are than the ordinary
kind. Your jobber will
supply you—also with
BULL DOG
TOE CALKS

"NEW EASY" 4 Sizes BOLT CLIPPERS "EASY" 2 Sizes

THE GENUINE TOOL



KNOWN AND PREFERRED EVERYWHERE

H. K. PORTER EVERETT, MASS. U. S. A.

EMPIRE STEEL WHEELS

Plain or grooved Tire

To Fit Any Wagon

Farm Trucks

All Standard Types

Write today for Proposition to Blacksmiths.

Empire Mfg. Co.
P. O. Box 308
QUINCY, ILLINOIS



The Woodworkers Friend



Woodstock and lumber is high. With our Jointer Heads you can buy rough lumber of any kind and dress it to suit the job. Saves time, money and lumber. Would this be any object to you? If so, get our circulars and prices. Sold on 30 day trial.

Mfg. by WHISLER MFG. CO., Gibson, Iowa



Best Gasoline Brazing Forge

IN THE WORLD

Thousands sold in last ten years. Four sizes. Send for catalog.

The National Rubber & Specialties Co.
4433-39 Chickering Ave., Winton Place,
Cincinnati, Ohio.

Four Cavity En Bloc Ribbed Retreader

Complete Gas Burner \$195.00

Complete Tire Shop Outfits—Sixty kinds of vulcanizers—EXTRA PLY TIRES repeat sales.

Write for Prices—Free 84-Page Catalog for the asking.

Write today Dept. "B"

CHAS. E. MILLER
Anderson, Ind., U.S.A.



The Perfect Power Hammer

The Simplest in Construction

The Most Effective in Operation

The Most Durable and

THE BEST

MADE IN TWO SIZES:

3 inch square, 49 lb. r a m — shipping weight, 1,100 lbs.

4 inch square, 80 lb. r a m — shipping weight, 1,800 lbs.

Write any jobber for Prices, or

MACGOWAN & FINIGAN FOUNDRY & MACHINE CO.
204 North Third Street
ST. LOUIS, MO.



HAVANA STEEL WHEELS

For your Farm Wagon, so as to make it a Low-Down, instead of having to do your work over the sides of a high wheeled wagon. No dry, loose wheels. More and easier work done.

Send postal for free catalog of Steel Wheels and Farm Trucks.

HAVANA METAL WHEEL CO.,
Box 85 Havana, Ill.



ACCESSORIES AND SUPPLIES OF INTEREST TO THE TRADE.

Continued from page 40.

Chapter 6—Airplane Fuselage Construction. Chapter 7—Airplane Power Plants. Chapter 8—Airplane Propeller Construction and Action. Chapter 9—Airplane Equilibrium and Control Principles—Notes on Flying. Chapter 10—How to Set up and Adjust Typical Airplane. Chapter 11—Inspection of Airplane. Chapter 12—Standard Aircraft Nomenclature and Dictionary of Terms.

BRINGING HOME THE BACON— AND THE PROFITS

The development of rural motor truck express lines and the use of trucks by the government for mail carrying purposes is doing more than anything else to relieve congestion in all transportation lines and the entire country is feeling the effects in a very satisfactory mood.

The conversion of passenger cars that have seen other and better days is about all that an old car is good for after it passes a certain stage of shabbiness, although the mechanical parts of the car may be, and generally are, in first class mechanical condition.

The prices of motor trucks will doubtless continue to be high for a considerable

period following final peace arrangements and along with this the buyer will possibly have to pay a tax in proportion to the sales price of the car. The salesman won't pay this tax, neither will the manufacturer, it will be Mr. Ultimate Consumer as usual.

Farmers and others feel the need of trucks and the quickness with which they transport goods and now that the war is over the business of selling motor truck units should respond to a little care like a house cat does to kind words.

This particular line has been well developed in the past but the near future will see big profits gathered in by those handling truck units—not any old truck unit, of course, the prospective dealer must choose the line he is going to carry with an eye to future re-orders and continued and satisfactory performance of the units he sells.

The New Way to Sell Truck Units is the title of a book that will be sent to our readers by the Lauton Truck Co., 558 Grand River Ave., Detroit Michigan, on request.

The Lauton Truck unit opens up a wider opportunity for profit than any other truck making attachment. That's why the Lauton plan is possible.

You couldn't take the Lauton plan and some other attachment and make a success of the combination.

With this plan and the Lauton unit to back it up, you do a bigger business, you sell on a better basis and you build for the future.

There is only one sensible course open to you as a good business man—to get the facts down to the last detail. Whether you are in a big city or a small one or in a rural community the Lauton sales plan is practical and profitable.

Experienced, energetic, successful passenger car and motor truck dealers, blacksmiths and tractor men are desired as Lauton dealers. In writing be sure and state briefly your business whether you are now selling truck attachments, and other facts indicative of your standing in the community.

Continued on page 44.

CLEAN YOUR ENGINE REGULARLY WITH A



One qt. kerosene and 6 lbs. air pressure cleans all dirt, grit and grease from engine. Prevents wear, actually saves half the usual repairs. Quick, economical, thorough, easy and cleanly to operate. Necessity for repair shops.

Wagner Specialty Co., 1942 Broadway, New York City

THE IMPROVED EASY HOOF TRIMMER

Will cut a hoof easier, quicker and better than any tool you have ever had. Weight 21-2 pounds, opening 7 inches, cuts one inch. Thousands of shoers are using the EASY HOOF TRIMMER with great satisfaction.

SEND \$1.50 TODAY

Delivered to any part of the U. S. by Parcel Post.

MUNCIE WHEEL CO., Muncie, Ind., U.S.A.



BALL AND ROLLER BEARINGS

All Types—IN STOCK—Many Sizes

THE GWILLIAM COMPANY ENGINEERS

253 W. 50th St. (at Broadway) NEW YORK
Branch: 1814 Arch St., Philadelphia





“SAVE THE PIECES!”

“All the King’s horses and all the King’s men couldn’t put Humpty-Dumpty together again.”

It’s a “One-man” job to restore broken or cracked metal parts to their original value and usefulness with Economy Welding and Cutting Outfits and Economy Acetylene Gas Generators

MAKE YOUR OWN ACETYLENE

Using the Economy Acetylene Gas Generator you can make your own acetylene gas; make more of it, for less money, and with no freight or hauling charges. UNCLE SAM needs the acetone in compressed acetylene—needs it bad—needs all he can get. Economy Acetylene Gas Generators do not require acetone.

Write for prices and catalogues to

Economy Welding Machine Company
213 Southwest Boulevard, KANSAS CITY, MO.
Manufacturers of Welder’s supplies and equipment of all kinds.

OUR FALL 1918 CATALOGUE IS READY

Get our new prices on Wheels, Spokes, Rims, Axles, Carriage and Wagon Hardware of all kinds, Steel and Iron Tires, Rubber Tires, Shafts, Plow Handles etc.

A. Wheel Top & Hardware Co.

129 E. 8th St.

Cincinnati, Ohio

We Tear ‘em up and Sell the Pieces

We save you 50 to 75 per cent on auto repairs. Can supply most any part needed.

Our Guarantee—If not satisfactory, can be returned, and money refunded.

Auto Wrecking Co.

13th and Oak Sts.,

KANSAS CITY, MO.

“Book Larnin’”

FEW if any men know all there is to know about their own particular business. — There’s something wrong with the man who “knows it all”—he’s either a fool or a most extraordinarily remarkable man.

Among the following list of books our readers will find works that will be of interest and value in increasing your ability and money making power:

| | | | |
|--|--------|---|------|
| High Speed Steel (Becker) | \$4.00 | Rogers’ Machinist’s Guide..... (Rogers) | 2.00 |
| Steel, Its Selection, Annealing, Hardening and Tempering | 2.50 | A Handbook of Art Smithing..... (Mayer) | 2.50 |
| Scientific Steel Worker..... (Westover) | 2.50 | Handbook of Practical Smithing and Forging | 2.00 |
| Hardening, Tempering and Forging of Steel | 2.50 | Forge Practice | 1.50 |
| (Woodworth) | 2.50 | Forging | 1.00 |
| The Blacksmith’s Guide | 1.50 | Forgecraft | 2.00 |
| Tool Making | 1.50 | Sheet Metal Work | 3.00 |
| Foundry Work | 1.00 | Machine Shop Practice | 1.25 |
| Drop Forging, Die Sinking and Machine Forming of Steel | 2.50 | Hand Forging and Wrought Iron Ornamental Work | 1.00 |
| Pattern Making | 1.00 | Machine Shop Work | 1.50 |
| Forging of Iron & Steel..... (Richards) | 1.50 | Plain and Ornamental Forging (Schwarzkopf) | 1.50 |
| Welding | 2.50 | Iron and Steel | 3.00 |
| | | | |

All books in this list are sent postpaid on receipt of price by the Book Department of the

American Blacksmith, Auto & Tractor Shop
BUFFALO, NEW YORK

N. B.—If you don’t see what you want in this list, ask about it—we’ll get it for you.

SHAFT

If you have never learned by actual experience just how good **Pioneer Shaft Ends** are, do it now by ordering a few of your jobber, and don't let him pawn off on you the "just-as-good," "may suit" brand. Look for the Pioneer trade-mark on the wrappers. Possibly you order a certain kind of horse nails and shoes because they are better and please. So why not specify **Pioneer Shaft Ends** for the same reason? Once you get acquainted, they will be your affinity ever afterwards.

Pioneer Shaft Ends are the kind that are easy to fit, and make the strongest joint.

THREE SIZES:—BUGGY, SURREY AND LIGHT BUGGY.

Made by **CRANDAL, STONE & COMPANY, BINGHAMTON, N. Y.**

"GET-A-WITTE"

**BUY
ON YOUR
OWN
TERMS**

KEROSENE ENGINE

DIRECT FROM FACTORY—FACTORY PRICES.

Own your farm or shop power at lowest cost. Get as much power for half the price, using kerosene. Choose your own terms—Cash, Payments, or No Money Down as arranged for. Save \$15 to \$200 buying direct—all fully explained in my new book—sent FREE on request.—Ed. H. Witte, Pres.

WITTE Engines

Stationary—Portable—Saw-Rig

are all made in the largest exclusive engine factory in the world dealing direct with user. My Free Factory Book, "How To Judge Engines", tells the whole story—tells why I can make a better engine and sell it for less. No need to pay higher prices than I ask to get the kind of an engine you want, or accept an "old style" or "back-number" to save money. Write for my new illustrated factory book and see just what a big offer I am able to make.

Witte Engine Works

1762 Oakland Ave. Kansas City, Mo.
1762 Empire Bldg. Pittsburgh, Pa.

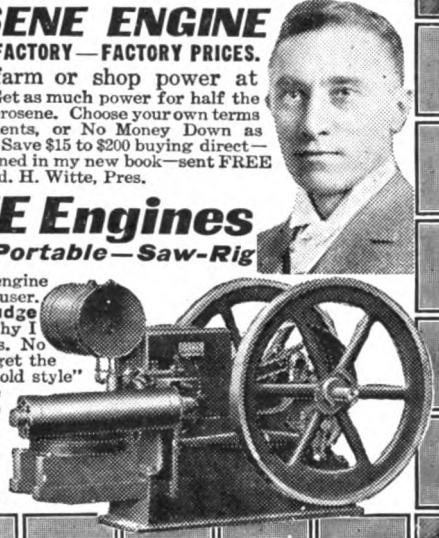

"MARVEL" Forge Blowers

This cut shows you the RING OIL BEARING design and construction of the motors used in our "ONE FIRE" \$38.00 MARVEL Blowers.

Note the large oil rings which revolve with the CASE HARDENED shaft, keeping it running in a perfect bath of oil on the bearings. Perfect Lubrication means long life.

Shipped on 30 days trial through your dealer.

Electric Blower Co.
Boston, Mass.

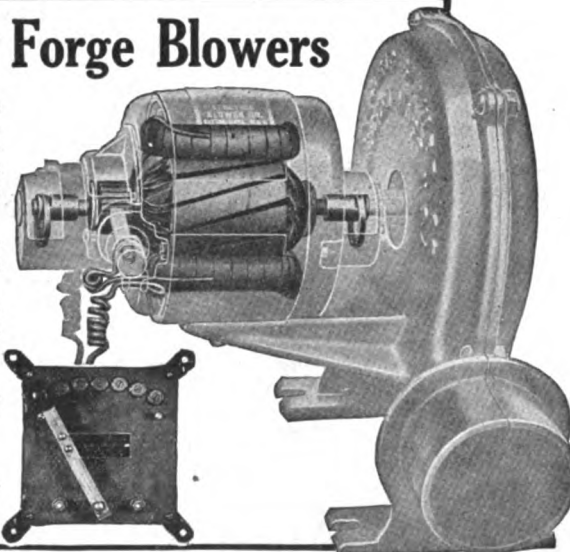

ACCESSORIES AND SUPPLIES OF INTEREST TO THE TRADE.

Continued from page 42.

"TOUCHING UP THE OLD BOAT"

In one of our recent numbers we published an article under the above heading

that presented some of the money making possibilities in renovating and refurbishing old automobiles that had lost the fluff and bloom of their early youth and some suggestions along the lines of curing sciatic tops and rheumatic seat cushions.

There are, in the length and breath of the land, men who could doubtless do all of these things without having recourse to call on anyone for assistance or take pointers from anyone on this particular line of work. The average repairman and garage man, however, is not particularly well versed in such matters and the frequent attempts to rehabilitate tops and seat cushions and side curtains result in only indifferent success and more often the time, material and expense involved in some of these rough and ready repairs is far more than a first class job would have cost.

Here again the results of specialization shows in the prices and quality of curtains, tops and cushions that can be obtained from him and while we're on the subject, permit us to introduce you to Messrs. Buob & Scheu, who do business at 350-360 Webster St., Cincinnati, Ohio. This firm is prepared to give results in all the articles mentioned. They make a specialty of special and regular tops for Fords that range in price from \$27.60 up complete (or they will furnish you with auto top coverings from \$7.45 up, all cut and ready to be attached to the top bows. This firm also manufactures tops and seats to fit any make or model of automobile, past or present. In addition to these lines, they manufacture fenders, radiator covers and all trimming accessories for the automobile upholsterer.

Somewhere in the advertising section of this number you will find Buob & Scheu's advertisement and it's worth the trouble to look it up. If you feel that you could use some extra dollars in your business, there's an opportunity in work of this sort that will merit prompt consideration. Whether you look up this firm's advertisement or not, write to them for a copy of their latest catalogue and price list. You don't even have to carry anything in stock but a catalogue and a tape measure. They'll send you the catalogue free and the other will possibly set you back about a dime.

Automobile prices aren't going to come down much for a long time yet and the man with a last year's car or one left over from the year before or the year before that isn't going to be in such a hurry about getting a new one, particularly if he knows he can get the old one fixed up as good as new at small expense. There is a steady demand for articles of character in every locality.

EVERY SHOER
should be sure and
specify _____

PHOENIX

Horse and Mule Shoes
when ordering. Then
you are sure of get-
ting the best. A trial
will show you HOW
MUCH better they
are---Also

BULL DOG

TOE CALKS

"NEW EASY" 4 Sizes BOLT CLIPPERS "EASY" 2 Sizes

THE GENUINE TOOL

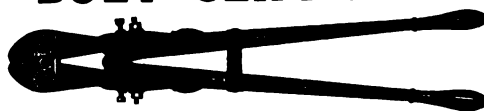

KNOWN AND PREFERRED EVERYWHERE

H. K. PORTER EVERETT, MASS. U. S. A.

EMPIRE STEEL WHEELS

Plain or grooved Tire To Fit Any Wagon

Farm Trucks

All Standard Types

Write today for Proposition to Blacksmiths.

Empire Mfg. Co.
P. O. Box 309
QUINCY, ILLINOIS



The Woodworkers Friend



Woodstock and lumber is high. With our Jointer Heads you can buy rough lumber of any kind and dress it to suit the job. Saves time, money and lumber. Would this be any object to you? If so, get our circulars and prices. Sold on 30 day trial. Mfg. by WHISLER MFG. CO., Gibson, Iowa



Best Gasoline Brazing Forge

IN THE WORLD

Thousands sold in last ten years. Four sizes. Send for catalog.

The National Rubber & Specialties Co.
4433-39 Chickering Ave., Winton Place,
Cincinnati, Ohio.

YOUR FINAL VERDICT

Vulcanizers

MILLER'S or ANDERSON for every use.

84 - Page Catalog Free on request.

Free Instructions.

Extra Ply Tires

Exclusive Territory Given

Write for New "Red White & Blue" Catalog and Tire Prices.

Address Dept. B
CHAS. E. MILLER
Anderson, Indiana,
1894 U. S. A. 1919

COMPLETE CURE ONE HEAT \$168.00

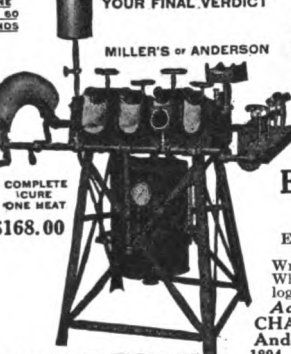

IMPROVED AIR-COOLED FLANGES

The Perfect Power Hammer

The Simplest in Construction

The Most Effective in Operation

The Most Durable and

THE BEST

MADE IN TWO SIZES:

3 inch square, 40 lb. ram — shipping weight, 1,100 lbs.

4 inch square, 80 lb. ram — shipping weight, 1,800 lbs.

Write any jobber for Prices, or

MACGOWAN & FINIGAN FOUNDRY & MACHINE CO.

204 North Third Street
ST. LOUIS, MO.



air vent which releases the vacuum in the cylinder when cranking piston up for re-filling.

To operate: Put gear shifting lever in upward position which engages high speed gears; turn crank until piston reaches top of cylinder, pull plunger and swing head to one side. Fill cylinder with grease or oil, swing head back over cylinder, turn

OTTAWA KEROSENE ENGINES

Start Easy in any weather. Pull steady. Carry big overload. All sizes and styles. 1 1/2 H-P. to 22 H-P. 90 Days' Trial. Money Back Guarantee. Prompt shipment.

Low Prices Write for present money saving prices and Free Book, telling all you want to know about engines. Write today.

OTTAWA MFG. CO. 1293 King Street, OTTAWA, KANS.



ACCESSORIES AND SUPPLIES OF INTEREST TO THE TRADE.

EKERN'S PORTABLE GARAGE GREASE GUN MODEL N. 56 POUNDS CAPACITY

CLEAN YOUR ENGINE REGULARLY WITH A

Wagner Auto Engine Cleaner



One qt. kerosene and 6 lbs. air pressure cleans all dirt, grit and grease from engine. Prevents wear, actually saves half the usual repairs. Quick, economical, thorough, easy and cleanly to operate. Necessity for repair shops.

Wagner Specialty Co., 1902 Broadway, New York City

Construction: Consists of a heavy seamless steel cylinder mounted on three wheels with five feet of hose attached to bottom of cylinder, having valve and nozzle at end of hose.

THE IMPROVED EASY HOOF TRIMMER

Will cut a hoof easier, quicker and better than any tool you have ever had. Weight 21-2 pounds, opening 2 inches, cuts one inch. Thousands of shiners are using the EASY HOOF TRIMMER with great satisfaction.

SEND \$1.50 TODAY

Delivered to any part of the U. S. by Parcel Post.

MUNCIE WHEEL CO., Muncie, Ind., U.S.A.



The register measures accurately the amount of grease put in the gear case or differential, and will work equally as well on liquid oil as on hard grease.

The head is equipped with two sets of gears. The worm gear is used when forcing grease into gear case, and the other when cranking the piston back up to the top for refilling the gear. The change of gears is made by merely moving the lever up or down. When the lever is up the quick return gears are engaged; when the lever is down the worm or low gears are engaged.



crank while high speed gears are engaged until piston reaches the grease in the cylinder. Push gear shifting lever down which engages worm or low gear; Set register by turning the indicator to 0 and turn crank until you have the amount of grease desired. The register will show the exact amount put into gear case. The register may be reset by merely turning indicator to zero.

When grease is used it registers in pounds. When oil is used it registers in pints. The same register is used for both oil and grease. Weight 175 lbs. List Price \$65.00.

BALL AND ROLLER BEARINGS

All Types—IN STOCK—Many Sizes

THE GWILLIAM COMPANY ENGINEERS

253 W. 58th St. (at Broadway) NEW YORK
Branch: 1314 Arch St., Philadelphia



The cylinder is thirty inches long and eight inches in diameter. Holds fifty-six pounds of grease or seven gallons of oil.

The piston is provided with best quality cup shaved leather and also has an expansion ring inside of leather which prevents any grease or oil from leaking by piston. The piston also has an automatic

NEW PRICES ON KEROSENE ENGINES

Those who are thinking of buying a farm engine will be interested in latest prices on the Witte—the better quality

Continued on Page 44



“SAVE- THE PIECES!”

“All the King’s horses and all the King’s men couldn’t put Humpty-Dumpty together again.”

It’s a “One-man” job to restore broken or cracked metal parts to their original value and usefulness with Economy Welding and Cutting Outfits and Economy Acetylene Gas Generators

MAKE YOUR OWN ACETYLENE

Using the Economy Acetylene Gas Generator you can make your own acetylene gas; make more of it, for less money, and with no freight or hauling charges.

UNCLE SAM needs the acetone in compressed acetylene—needs it bad—needs all he can get. Economy Acetylene Gas Generators do not require acetone.

Write for prices and catalogues to

Economy Welding Machine Company

213 Southwest Boulevard, KANSAS CITY, MO.
Manufacturers of Welder’s supplies and equipment of all kinds.

Finished Buggy Shafts
\$10.00 Per Bundle of 6 Pairs

Oak Wagon Spokes
\$3.65 Per Set and Up

Plain Hickory Rims
\$2.15 Per Set and Up

Sarven Wheels
\$11.90 Per Set and Up

Repair Grade Sarven Spokes
\$2.50 Per 100

Auto Top Re-Covers
\$8.20 and Up, Parcels Post Paid

AUTO TIRES 30 x 3 1/2 NON SKID \$14.75
Other Sizes in Proportion

WHEEL TOP & HARDWARE CO.
Dep’t W1 Get our Catalogue Cincinnati, Ohio

We Tear ’em up and Sell the Pieces

We save you 50 to 75 per cent on auto repairs. Can supply most any part needed.

Our Guarantee—If not satisfactory, can be returned, and money refunded.

Auto Wrecking Co.

13th and Oak Sts., KANSAS CITY, MO.

Good Books for the Craft

The following selected titles are the best books to be obtained on their respective subjects. The American Blacksmith, Auto and Tractor Shop will gladly supply you, postpaid, with any of the following, cash with order. We can also get for you and book desired.

Craft Books

| | |
|---|--------|
| Steel, Its Selection, Annealing, Hardening and Tempering..... (Markham) | \$3.00 |
| The Blacksmith’s Guide..... (Slalows) | 1.50 |
| Tool Making..... (Markham) | 1.50 |
| Foundry Work..... (Stimpson) | 3.00 |
| Drop Forging, Die Sinking and Machine Forming of Steel..... (Woodworth) | 3.00 |

Horseshoeing

| | |
|--|------|
| Rich’s New Artistic Horseshoeing..... (Rich) | 1.00 |
| Textbook of Horseshoeing..... (Lungwitz) | 2.25 |
| Art of Horseshoeing..... (Hunting) | 1.25 |

Gas Engines

| | |
|------------------------------------|------|
| The Modern Gas Tractor..... (Page) | 2.50 |
|------------------------------------|------|

Oxy-Acetylene Work

| | |
|---|------|
| Oxy-Acetylene Welding and Cutting..... (Willis) | .50 |
| Oxy-Acetylene Welding and Cutting..... (Manly) | 1.00 |

Automobiles

| | |
|---|------|
| Automobile Repairing Made Easy..... (Page) | 3.50 |
| Modern Starting, Lighting and Ignition System..... (Page) | 2.00 |
| Storage Batteries Simplified..... (Page) | 2.00 |
| The Modern Gasoline Automobile (new edition 1918)..... (Page) | 3.50 |
| Questions and Answers Relating to Modern Automobiles..... (Page) | 2.00 |
| The Model T. Ford Car..... (Page) | 1.00 |
| Dyke’s Automobile and Gasoline Engine Encyclopedia (new 1918 edition)..... (Dyke) | 4.00 |

The American Blacksmith, Auto and Tractor Shop
BOOK DEPARTMENT

If you have never learned by actual experience just how good **Pioneer Shaft Ends** are, do it now by ordering a few of your jobber, and don't let him pawn off on you the "just-as-good," "may suit" brand. Look for the Pioneer trade-mark on the wrappers. Possibly you order a certain kind of horse nails and shoes because they are better and please. So why not specify **Pioneer Shaft Ends** for the same reason? Once you get acquainted, they will be your affinity ever afterwards.

Pioneer Shaft Ends are the kind that are easy to fit, and make the strongest joint.

THREE SIZES:—BUGGY, SURREY AND LIGHT BUGGY.

Made by **CRANDAL, STONE & COMPANY, BINGHAMTON, N. Y.**

GET-A-WITTE

BUY ON YOUR OWN TERMS

KEROSENE ENGINE

DIRECT FROM FACTORY—FACTORY PRICES.

Own your farm or shop power at lowest cost. Get as much power for half the price, using kerosene. Choose your own terms—Cash, Payments, or No Money Down as arranged for. Save \$15 to \$200 buying direct—all fully explained in my new book—sent FREE on request.—Ed. H. Witte, Pres.

WITTE Engines

Stationary—Portable—Saw-Rig



are all made in the largest exclusive engine factory in the world dealing direct with user. My Free Factory Book, "How To Judge Engines", tells the whole story—tells why I can make a better engine and sell it for less. No need to pay higher prices than I ask to get the kind of an engine you want, or accept an "old style" or "back-number" to save money. Write for my new illustrated factory book and see just what a big offer I am able to make.

Witte Engine Works

1763 Oakland Ave. Kansas City, Mo.
1763 Empire Bldg. Pittsburgh, Pa.

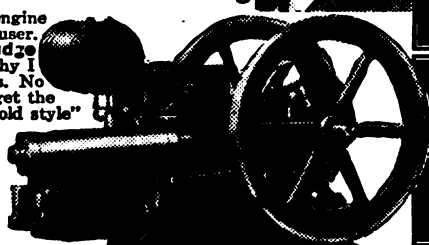

HAVANA STEEL WHEELS



For your Farm Wagon, so as to make it a Low-Down, instead of having to do your work over the sides of a high wheeled wagon. No dry, loose wheels. More and easier work done. Send postal for free catalog of Steel Wheels and Farm Trucks. HAVANA METAL WHEEL CO., Box 85 Havana, Ill.

ed folder, showing what Witte users are doing, together with latest prices, mailed free on request. Witte Engine Works, 1760 Oakland Ave., Kansas City, Mo., 1760 Empire Bldg., Pittsburgh, Pa.

FAMOUS SHOER OF TROTTING HORSES DEAD

William J. Moore, for more than 20 years expert horseshoer and blacksmith at the famous Allen farm, died recently at his home in West Springfield.

Mr. Moore was known as the most scientific horseshoer in western Massachusetts. He wrote a book that is an authority on correction of faulty action in driving and racing horses. The great success of William Russell Allen's racing horses was due more to the remarkable skill of Mr. Moore than any other man, for no one in this region had horse-shoeing down to such an exact science.

He knew that the variation of a fraction of an inch in the action of a horse's foot meant success or failure. He corrected with unerring precision such faults as forging, scalping, hitching and interfering. He developed Mr. Allen's horses either as pacers or trotters by the action of the feet by means of a steel plate. Mr. Moore had all the tricks of the trade down fine. His life work was to make living and moving a trifle easier for the horse. He had as sincere an interest in this dumb friend of man as the surgeon has in the welfare of humans. That which was hidden from some men was perfectly plain to him always. He could seek out a concealed flaw only to remedy it with speed and precision. Horses got so they knew him and stood patiently while he applied corrective measures.

"MARVEL" Forge Blowers

This cut shows you the RING OIL BEARING design and construction of the motors used in our "ONE FIRE" \$38.00 MARVEL Blowers.

Note the large oil rings which revolve with the CASE HARDENED shaft, keeping it running in a perfect bath of oil on the bearings. Perfect Lubrication means long life.

Shipped on 30 days trial through your dealer.

Electric Blower Co.
Boston, Mass.

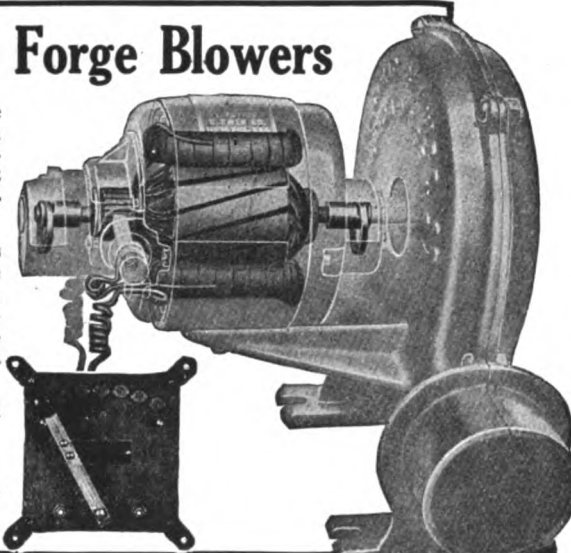

ACCESSORIES AND SUPPLIES OF INTEREST TO THE TRADE.

Continued from Page 42

engine—longest on the market, easiest to use fuel saving, reliable. As usual the Witte factory offers the most favorable prices to the customer, and now as before

the war, and during the war, buyers can buy on practically their own terms. Every Witte engine—gasoline or kerosene—is sold on a valid 5-year guarantee backed by the largest exclusive engine factory in the world selling direct to user. A handsome new engine catalog, and big illustrat-

BALANCING AND SHOING TROTTING AND PACING HORSES
by Wm. J. Moore, Farrier at Allen Farm for 20 years
"Foot Fixing and Shoeing to Control Faulty Action"
The most complete, scientific and practical work ever offered to the public. Endorsed by the late William Russell Allen. Price \$1.00 per copy.
Address all orders to
JOHN B. STONE,
7 North Street, Pittsfield, Mass.

Install a Curtis Air Compressor



The Curtis Sign

Illustrated above—is 10x14 inches—baked enamel on steel. Cannot be bought, but is furnished FREE with every CURTIS Garage Air Compressor—and cannot be had in any other way.

Display a CURTIS "FREE AIR" SIGN above your door—it inspires confidence and will help build your business. Motorists are looking for this familiar CURTIS slogan—because they know oil rots tires—and that a CURTIS Air Compressor furnishes AIR FREE FROM OIL, which means fewer blowouts, greater tire mileage and less repairs. The CURTIS is the ONLY Garage Air Compressor with the controlled splash oiling system that eliminates all danger of forcing oil into the air line.

CURTIS AIR FREE FROM OIL

Investigate the many exclusive features of CURTIS Garage Air Compressors. The line is complete—five sizes—stationary or portable. Just write your name and address on the margin of this advertisement—tear it out and send it to your jobber, or to us direct, for complete information and prices.

Curtis Pneumatic Machinery Co.
1514 Kienlen Ave., St. Louis, Mo.
Branch Office—530-M Hudson Terminal, New York City

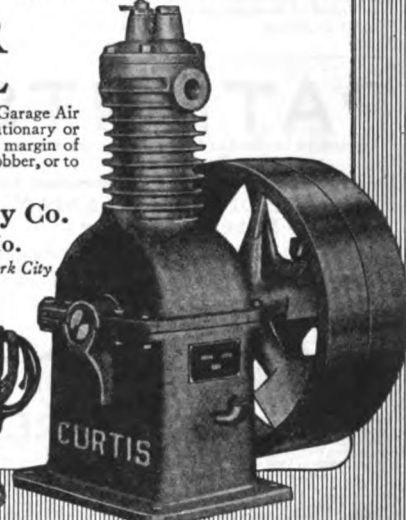

THE VETERAN HORSESHOER LOOKS BACK UPON **35 YEARS** OF COMPLETE SATISFACTION WITH THE **BOSS IRON & BANNER STEEL** **HORSE AND MULE SHOES**

and we strive NOW to maintain that standard of quality which marked so plainly the "BOSS" shoe in 1882.

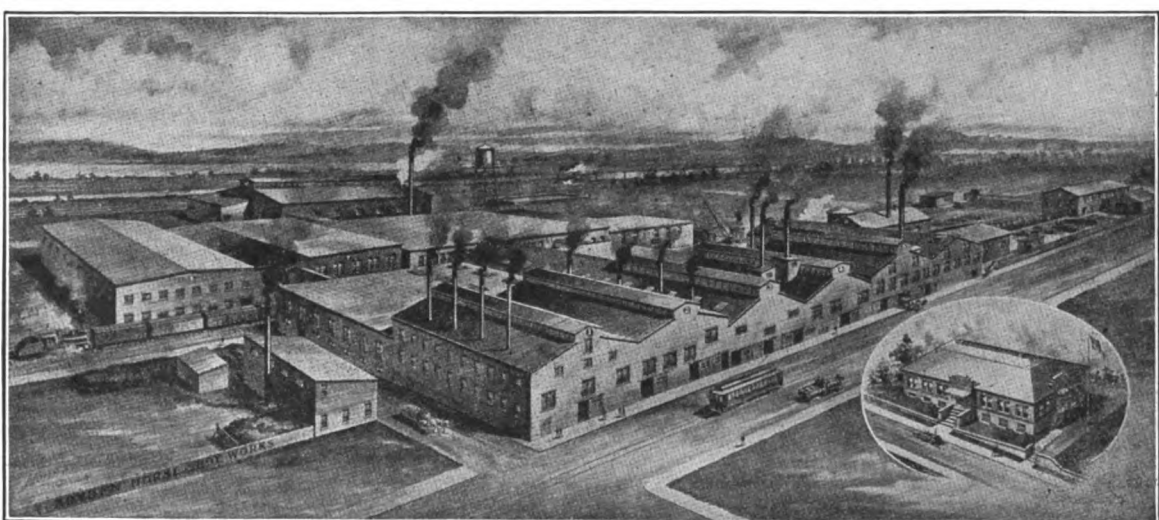

Bryden Horse Shoe Works

Catasaqua, Penna.

SEND FOR DESCRIPTIVE CATALOG.

CUMMINGS & EMERSON
BLACKSMITH SUPPLIES
 Send for net price plow goods catalogue.
PEORIA, ILLINOIS

PATENTS **HERBERT JENNER,**
 Patent Attorney and Mechanical Expert, 622 F St., Washington, D. C. Established 1883. I make a free examination and report if a patent can be had and exactly what it will cost. Send for circular.

PATENTS
C. L. PARKER
Ex-Member Examining Corps, U. S. Patent Office
Attorney-at-Law and Solicitor of Patents
 American and foreign Patents secured. Trade marks registered. Searches made to determine patentability, validity and infringement. Patent Suits conducted. Pamphlet of instructions sent upon request.
 McGill Building WASHINGTON, D. C.

PATENTS
 Inventors Invited to Write for Information and Particulars.
 Highest References, Best Results, Promptness Assured.
WATSON E. COLEMAN
Patent Lawyer
 624 F Street N. W., Washington, D. C.



BUSH CAR—FREE
 This Five Passenger 37 H. P. car, 116 in. whl. base. All bearings Timken. Delco Ign.—Dynamo Stg. and Ltg. Write at once for my great Free Offer and 48-page catalog. Agents wanted to drive and demonstrate. Territory open. Prompt shipments. Big money. Cars guaranteed or money back. 1919 cars ready.
 Address J. M. Bush, President, Dept. C-2, BUSH MOTOR CO., Bush Temple, Chicago, Illinois

WANTED AND FOR SALE

Want and For Sale advertisements, situations and help wanted, five cents a word. Send cash with order. No charge less than fifty cents. The small cost of these advertisements prevents our investigating and guaranteeing them. **WE WILL NOT** knowingly accept any but reliable ones.

WANTED—To hear from owner of good Blacksmith Shop for sale. State cash price, description. **D. F. BUSH, Minneapolis, Minn.**

FOR SALE—Blacksmith and General Repair power shop. Work for two men. Address, **Box No. 245, Orchard Neb.**

FOR IMMEDIATE SHIPMENT:—9 in. Jointers \$50.00—5 in. \$35.00. Bench Jointers 5 in. \$30.00—14 in. square style cutter head with attachments \$20.00. Circular style cutter heads for wood frame Jointers from 5 to 12 in. Combined outfits Jointer head and Pole rounding head Jointer and saw arbor with various attachments, Saw Arbors and Emery Stands. Catalogue No. 15, for the asking.
W. L. SHERWOOD, Kirksville Mo.

FOR SALE—Brooks Edge Grip Cold Tire Setter. Cheap. No longer needed.
J. W. DEVERS, Trotwood, Ohio.

FOR SALE:—Automobile, Marine and stationary engines 1 to 100 H. P. Best makes, good condition, very low prices. State your power needs. We take engines in trade. What have you? Magnets, coils, carburetors, mechanical oilers, water pumps, etc. Also car parts of every nature—sacrifice prices. Write about your requirements.
BADGER MOTOR COMPANY, Milwaukee, Wis.

FOR SALE OR RENT:—Blacksmith Shop, House & Barn and ½ acre of land on State Road 16 miles south of Utica in good farming country. Terms easy.
H. SEIFERT, Bridgewater, N. Y.

OPPORTUNITY—Good shop, tools, machinery and stock in good territory. Take \$1,000 for contents \$900 for shop or trade contents for fruit land in California Community near school. **MRS. RUTH DALGLEISH, Lower Lake, Lake Co. California.**

Pat. Oct. 19, 1909.

Use These Self Sharpening Toe Calks

Ludvigsen Bros. Welded Steel Center Calks are the choice of MANY horseshoers because they always give satisfaction.

THE HARD STEEL PLATE in the center and the two outside plates are welded together and shaped to a sharp calk that stays SHARP while it WEARS DOWN.

Sizes, 0 to 7.

We will gladly mail a sample of this calk to any reader of The American Blacksmith on request. **BE SURE TO TELL YOUR JOBBER** you want **LUDVIGSEN BROS. WELDED STEEL CENTER TOE CALKS.**

LUDVIGSEN BROS.,
JACKSON, MINN.,
 or 47 Second St., MILWAUKEE, WIS.

The Sunderman Vacuum Carburetor

positively saves from 30% 50% of gasoline in any motor.

It increased mileage 128% on a Ford car in the New York Herald test at the Sheepshead Bay Speedway in October of this year.

Splendid dealer proposition—write for it.
THE SUNDERMAN CORPORATION,
 42 Chambers Street, Newburgh, N. Y.

WANTED: Wagon maker who can build auto and truck bodies. Steady job.
E. T. PYBUS, Wenatchee, Wash.

FOR SALE: My power blacksmith shop, complete. In Illinois town of 600 on electric and steam road. Address,
C. F. T. c/o American Blacksmith.

BLACKSMITHS LISTEN: Save time and money by doing your own auto and tractor blacksmithing with Toy's modern methods doing hard jobs easy. Forging and making solid welds, hardening and tempering to a standard, with colored tempering charts. All for one dollar. Samples free. **W. M. TOY, Sidney, Ohio.**

ACCESSORIES AND SUPPLIES OF INTEREST TO THE TRADE.

Automotive Starting, Lighting, and Ignition—Fryer—This volume, primarily intended to form the basis of a lecture course on starting, lighting and ignition has been made as general and concise as practicable, with the idea in view that it should include the essential knowledge necessary to the student; and that it will be valuable to him when properly enlarged upon with demonstration by capable instructors.

This book was written to help in the work of War Education and while essentially a class room book that requires models and demonstration for its proper application it is a valuable work for all students of electrical systems inasmuch as a great part of the book is devoted to wiring and circuit diagrams of various systems and devices. There is also a wealth of valuable electrical information contained within its covers that make it a decidedly valuable addition to the list of books on this subject. The price of this book is \$1.25.

THE ROWE CALK & CHAIN COMPANY JOINS MOVEMENT FOR HIGHER BUSINESS STANDARDS.

The Rowe Calk & Chain Company of Plantsville, Conn. has become a member
 (Continued on Page 42.)

1919 Model—The L. S. P. Calking Machine

The Greatest Time and Labor Saving Machine on Earth

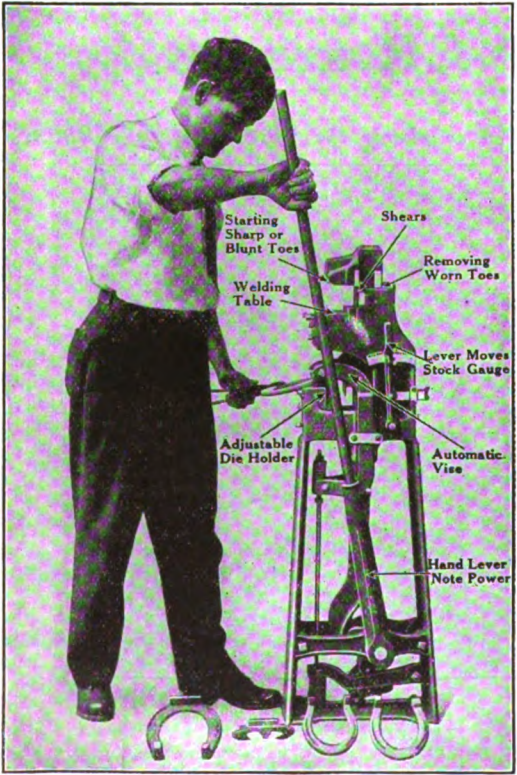

1919 MODEL
 Fully covered with Patents

OUR 1919 Model is the same as our 1918. We agree with the users and so would you that it can not be improved.

Do not mistake this for a machine which makes toe calks or a foot vice. This machine is for turning heel calks, both Blunt and Sharp, sticking and welding toe calks, clipping and trimming ends of shoes. **IT CALKS SHOES,** doing the work just the same as you do by hand with the hammer, only it is done much better and easier, and in a fraction of the time.

In turning heels, you can turn up just as much stock as you wish, upset or stoveup to make as heavy as you like and square up the calks without use of hammer. There is no losing of toes when you weld on the L. S. P.

It is a strong, handsome, well-made machine, and will last, as you might say, a life time, fully warranted for one year. It is in use in the best shops in the United States, users claiming more for it than we do. Write at once for full information and prices.

L. S. P. CALKING MACHINE COMPANY
 Peoples' State Bank Building
 Wyalusing, Pa., U. S. A.
 National Machine Co.,
 Brighton, Ont., Canada



Higher Prices but Bigger Cash Saving

If you're John Wiseman you used STANDARD Toe Calks last year and copped the saving.

If you're Bill from Missouri, now is the time to admit that you've been shown.

You make about *twice* the cash saving this year that John Wiseman made last year by using STANDARD Toe Calks.

Prices are up on all steel products—hence the greater cash saving and the added necessity for saving every cent.

You don't buy the Calk Box. You buy the Calks in the box, and there are more STANDARD Toe Calks to the box. And there's just one quality—THE BEST.

Buy from your dealer. He can get STANDARD CALKS for you. (No. 1)



**FRANKLIN
STEEL WORKS**

JOLIET, ILL.
CAMBRIDGE, MASS.
HAMILTON, ONT.



LINDE OXYGEN

From Coast to Coast 65 Producing Plants and Distributing Stations provide an unlimited supply of Linde Oxygen for users everywhere.

LINDE SERVICE means no investment except for oxygen actually received—no expensive overhead or upkeep charges. Linde Oxygen may be obtained from any of the following Linde Plants and Distributing Stations where a large supply of charged 100 and 200 cu. ft. cylinders is kept on hand constantly to insure immediate shipments.

Mail or telephone your order to THE LINDE AIR PRODUCTS CO., at the nearest point. Shipments will be made on day order is received.

Distributing Stations

- Alabama
 - *Birmingham
10th Ave. & 28th St.
- California
 - *Emeryville, Oakland
 - *Los Angeles
1405 Mission Road
- Colorado
 - Denver
1017 17th St.
- Connecticut
 - Hartford
1095 Main St.
- District of Columbia
 - Washington
9th & Maryland Ave., S. W.
- Georgia
 - *Atlanta
Plyant St. & Southern R. R.
- Savannah
 - Ogeechee Canal, So. of Bay St.
- Illinois
 - *Chicago
3633 Wall St.
 - East St. Louis
6th & Walnut Ave.
- Peoria, Ill.,
721-731 So. Washington St.
- Indiana
 - *East Chicago
S. E. Cor. Kennedy & 145th Street
 - Fort Wayne
414 E. Columbia St.
 - *Indianapolis
2819 Roosevelt Ave.
- Iowa
 - Davenport
118 Harrison Street.
 - Des Moines
117 W. 5th Street
- Kansas
 - Wichita
Rock Island Ave. & 2nd St.
- Kentucky
 - Louisville
126 E Main St.
- Louisiana
 - New Orleans
861 Fulton St.
- Maryland
 - *Baltimore
25th & Montebello Ave.
- Massachusetts
 - Cambridge
25 Waverly St.
 - Springfield
Napier St.
 - *Worcester
961 Southbridge St.
- Michigan
 - *Detroit
St. Aubin Ave. & Newton St.
 - Grand Rapids
Pearl St. by the Bridge
- Minnesota
 - Duluth
Seventh Ave. West
 - *Minneapolis
1809 Hennepin Ave.
- Missouri
 - *No. Kansas City
14th & Charlotte St.
 - *St. Louis
4218 Forest Park Blvd.
- Nebraska
 - Omaha
1007 Jones St.
- New Jersey
 - *Elizabeth
Linden Ave.
- Newark
 - 854 Plane St.
- New York
 - Albany
Montgomery & Colonie Sts.
 - *Brooklyn
475 Driggs Ave.
 - *Buffalo
Broadway & Ideal Sts.
 - New York City
217 W. 29th St.
 - New York City (Bronx)
8168 Park Ave.
 - *Utica
Walnut & Schuyler Sts.
- Ohio
 - *Cleveland
802 East 72nd Street
 - *Cincinnati
Stanton & Mellish Aves.
 - Columbus
810 Dublin Ave.
 - Dayton
621 E. First St.
 - Lima
538 East High St.
 - Toledo
441 S. Erie St.
 - *Youngstown
601-621 Jones Street
- Oklahoma
 - Oklahoma City
27 E. Grand Ave.
 - Tulsa
1 North Boulder St.
- Oregon
 - Portland
15th & Hoyt Sta.
- Pennsylvania
 - Allentown
211 Gordon St.
 - Erie
1502 Sassafras St.
 - *Norristown
*No. Philadelphia
18th & Cambria Sts.
 - Pittsburgh
16th & Pike Sts.
 - *Trafford
- Tennessee
 - Chattanooga
212 to 238 King St.
 - Memphis
203 Washington St.
- Texas
 - *Dallas
Harwood & Coombs St.
 - Houston
Cedar & Baker Sts.
 - San Antonio
512 Dolorosa St.
- Utah
 - Salt Lake City
112 W. Second St. South
- Virginia
 - Norfolk
22nd St. & Colonial Ave.
 - Richmond
1709 E. Carey St.
- Washington
 - Seattle
580 First Ave. South
 - Spokane
121-123 S. Madison St.
- Wisconsin
 - Manitowac
810 Quay St.
 - *Milwaukee
86th St. & National Ave.

(*) designates plants
Other plants and Distributing Stations are planned for other industrial centers throughout the country and will be established as fast as and wherever the local demand for oxygen warrants.

The Linde Air Products Company
Largest Producers of Pure Oxygen in America
Forty-Second St. Building, NEW YORK

YOU

Can easily prove to your own satisfaction that a set of
BUTTERFIELDS
Combination Auto Screw Plates

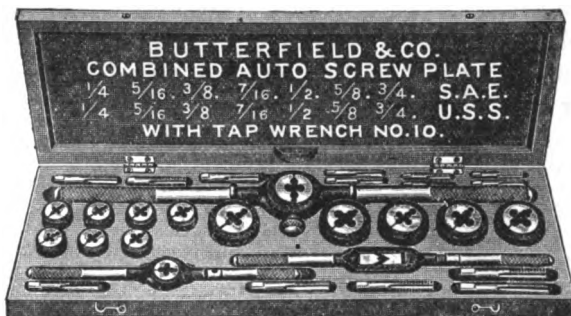

is the most economical thread cutting outfit you could possibly buy.

Ask your nearest Dealer and at the same time write for a copy of our new Catalog No. 17.

Butterfield & Co., Inc.

DERBY LINE, VT.,

U. S. A.

"NEW EASY" 4 Sizes BOLT CLIPPERS "EASY" 2 Sizes

THE GENUINE TOOL

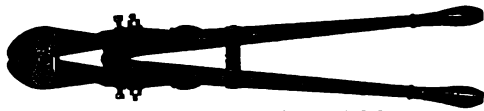

KNOWN AND PREFERRED EVERYWHERE

H. K. PORTER EVERETT, MASS. U. S. A.

EMPIRE STEEL WHEELS

Plain or grooved Tire
To Fit Any Wagon



Farm Trucks
All Standard Types

Write today for Proposition to Blacksmiths.

Empire Mfg. Co.
P. O. Box 309
QUINCY, ILLINOIS

The Woodworkers Friend



Woodstock and lumber is high. With our Jointer Heads you can buy rough lumber of any kind and dress it to suit the job. Saves time, money and lumber. Would this be any object to you? If so, get our circulars and prices. Sold on 30 day trial. Mfg. by WHISLER MFG. CO., Gibson, Iowa

Four Cavity En Bloc Ribbed Retreader

Complete Gas Burner \$195.00



Complete Tire Shop Outfits—Sixty kinds of vulcanizers—EXTRA PLY TIRES repeat sales.

Write for Prices—Free 84-Page Catalog for the asking.

Write today Dept. "B"

CHAS. E. MILLER
Anderson, Ind., U.S.A.

The Perfect Power Hammer

The Simplest in Construction
The Most Effective in Operation
The Most Durable and



THE BEST

MADE IN TWO SIZES:

3 inch square, 40 lb. ram — shipping weight, 1,100 lbs.

4 inch square, 80 lb. ram — shipping weight, 1,800 lbs.

Write any jobber for Prices, or

MACGOWAN & FINIGAN FOUNDRY & MACHINE CO.
204 North Third Street
ST. LOUIS, MO.

OTTAWA KEROSENE ENGINES



Start Easy in any weather. Pull steady. Carry big overload. All sizes and styles. 1 1/2 H-P. to 22 H-P. 90 Days' Trial. Money Back Guarantee. Prompt shipment.

Low Prices Write for present money saving prices and Free Book, telling all you want to know about engines. Write today.

OTTAWA MFG. CO. OTTAWA, KANS.

CLEAN YOUR ENGINE REGULARLY WITH A



Wagner Auto Engine Cleaner

One qt. kerosene and 6 lbs. air pressure cleans all dirt, grit and grease from engine. Prevents wear, actually saves half the usual repairs. Quick, economical, thorough, easy and cleanly to operate. Necessity for repair shops.

Wagner Specialty Co., 1902 Broadway, New York City

THE IMPROVED EASY HOOF TRIMMER

Will cut a hoof easier, quicker and better than any tool you have ever had. Weight 21-2 pounds, opening 2 inches, cuts one inch. Thousands of shoers are using the EASY HOOF TRIMMER with great satisfaction.

SEND \$1.50 TODAY

Delivered to any part of the U. S. by Parcel Post.

MUNCIE WHEEL CO., Muncie, Ind., U.S.A.



BALL AND ROLLER BEARINGS

All Types—IN STOCK—Many Sizes

THE GWILLIAM COMPANY ENGINEERS

253 W. 58th St. (at Broadway) NEW YORK
Branch: 1314 Arch St., Philadelphia



More Men Are Now Driving Their Own Cars Than Ever Before

The war has done it. And these driver-owners, men and women, many of whom would ordinarily depend on their service stations, even for minor repairs, find themselves up against the universal short-handedness. Consequently, more and more of them turn to the

1919 EDITION OF

THE MODERN MOTOR CAR

By HAROLD P. MANLY

"The Bible of Simplified Upkeep"

That's because they find in it everything they can possibly want to know about their car "in sickness or in health." *Motor World* says: "The most illuminating and instructive work of its kind . . . Indispensable to novice and expert." Care, repair and upkeep for every type, old and new. Shop and roadside methods of trouble location and remedy. All latest and best ideas. Detailed instructions for 36 models of carburetors.

Flexible Keratol; round corners; 538 pp.; 225 illustrations; 5x7 1/2 inches. **\$2.00**

NEWEST AND BEST FOR OWNER, DRIVER, REPAIRMAN AND SALESMAN



Best Gasoline Brazing Forge
IN THE WORLD

Thousands sold in last ten years. Four sizes. Send for catalog.

The National Rubber & Specialties Co.
4433-39 Chickering Ave., Winton Place,
Cincinnati, Ohio.

ACCESSORIES AND SUPPLIES OF INTEREST TO THE TRADE.
(Continued from Page 40.)

of the Rice Leaders of the World Association, thereby joining in cooperative movement to foster greater appreciation for right business standards, and for products manufactured under those standards.



Included in the membership are such manufacturers as the American Vulcanized Fibre Co., The Borden Co., Frank Mossberg Company, The L. S. Starrett Co., Van Dorn Electric Tool Co., Winchester Repeating Arms Co., and a number of others—all concerns whose business principles have been such as to gain the confidence of millions of satisfied customers.

The Rowe Calk & Chain Co., was one of the pioneers in the manufacture of screw and drive removable horseshoe calks. Its products are in use all over the country, and have given universal satisfaction in the horseshoeing trade. The concern also manufactures the well-known "Prest-O-Grip" Anti-Skid Chain for Automobile Trucks.

Its official family includes Warren D. Chase, President; E. S. Bestor, Secretary; H. R. Von Wessely, Treasurer; and L. B. Powell, Sales Manager.

A MACHINE OF INTEREST

The Universal Wheel Compressor Co., whose advertising appears in this issue have a machine of considerable usefulness

(Continued on Page 44.)

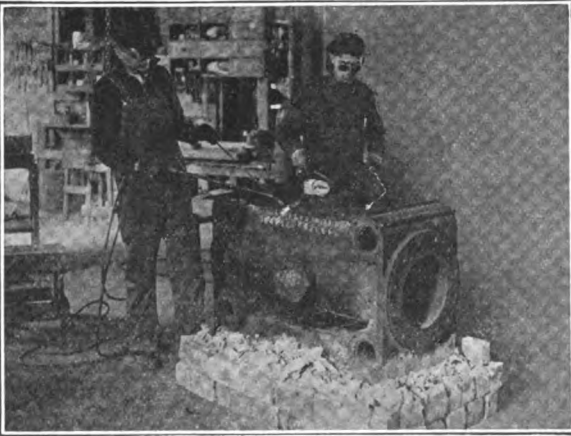

“SAVE THE PIECES!”

“All the King’s horses and all the King’s men couldn’t put Humpty-Dumpty together again.”

It’s a “One-man” job to restore broken or cracked metal parts to their original value and usefulness with Economy Welding and Cutting Outfits and Economy Acetylene Gas Generators

MAKE YOUR OWN ACETYLENE

Using the Economy Acetylene Gas Generator you can make your own acetylene gas; make more of it, for less money, and with no freight or hauling charges. UNCLE SAM needs the acetone in compressed acetylene—needs it bad—needs all he can get. Economy Acetylene Gas Generators do not require acetone.

Write for prices and catalogues to

Economy Welding Machine Company

213 Southwest Boulevard, KANSAS CITY, MO.
Manufacturers of Welder’s supplies and equipment of all kinds.

Finished Buggy Shafts
\$10.00 Per Bundle of 6 Pairs

Oak Wagon Spokes
\$3.65 Per Set and Up

Plain Hickory Rims
\$2.15 Per Set and Up

Sarven Wheels
\$11.90 Per Set and Up

Repair Grade Sarven Spokes
\$2.50 Per 100

Auto Top Re-Covers
\$8.20 and Up, Parcels Post Paid

AUTO TIRES 30 x 3 3/4 NON SKID \$14.75
Other Sizes in Proportion

WHEEL TOP & HARDWARE CO.
Dep’t W1 Get our Catalogue Cincinnati, Ohio

Dealers! Garagemen!
Put in a complete, assorted stock of
VULCAN SPRINGS



Link up Spring Service for Your Customers with Vulcan “Spring Service for the Nation”. Write now for our special proposition of assorted stock of quick sellers, with Display Rack, Doorsign, Window Transfers, etc.—Free.

Jenkins Vulcan Spring Co.,
Richmond, Indiana.

Stock Carried at These Branches:
St. Louis, Mo. 1402 Chestnut St.
Minneapolis, Minn. 1024 Hennepin Ave.
Dallas, Texas 209 So. Houston St.
Reading, Pa. 538 Franklin St.
Sumter, S. C. 29 Caldwell St.
Atlanta, Ga. 48 Auburn Ave.

Good Books for the Craft

The following selected titles are the best books to be obtained on their respective subjects. The American Blacksmith, Auto and Tractor Shop will gladly supply you, postpaid, with any of the following, cash with order. We can also get for you and book desired.

Craft Books

| | |
|---|--------|
| Steel, Its Selection, Annealing, Hardening and Tempering..... (Markham) | \$3.00 |
| The Blacksmith’s Guide..... (Slalows) | 1.50 |
| Tool Making..... (Markham) | 1.50 |
| Foundry Work..... (Stimpson) | 3.00 |
| Drop Forging, Die Sinking and Machine Forming of Steel..... (Woodworth) | 3.00 |

Horseshoeing

| | |
|--|------|
| Rich’s New Artistic Horseshoeing..... (Rich) | 1.00 |
| Textbook of Horseshoeing..... (Lungwitz) | 2.25 |
| Art of Horseshoeing..... (Hunting) | 1.25 |

Gas Engines

| | |
|------------------------------------|------|
| The Modern Gas Tractor..... (Page) | 2.50 |
|------------------------------------|------|

Oxy-Acetylene Work

| | |
|---|------|
| Oxy-Acetylene Welding and Cutting..... (Willis) | .50 |
| Oxy-Acetylene Welding and Cutting..... (Manly) | 1.00 |

| | |
|--|------|
| Oxy-Acetylene Flame..... (Dunham) | 1.25 |
| Forge Practice..... (Bacon) | 1.50 |
| Forging..... (Jernberg) | 1.00 |
| Hand Forging and Wrought..... (Googerty) | 1.00 |
| Iron Ornamental Work..... | |
| Plain and Ornamental Forging.... (Schwarzkopf) | 1.50 |

Automobiles

| | |
|---|------|
| Automobile Repairing Made Easy..... (Page) | 3.50 |
| Modern Starting, Lighting and Ignition System..... (Page) | 2.00 |
| Storage Batteries Simplified..... (Page) | 2.00 |
| The Modern Gasoline Automobile (new edition 1918)..... (Page) | 3.50 |
| Questions and Answers Relating to Modern Automobiles..... (Page) | 2.00 |
| The Model T. Ford Car..... (Page) | 1.00 |
| Dyke’s Automobile and Gasoline Engine Encyclopedia (new 1919 edition)..... (Dyke) | 4.00 |

The American Blacksmith, Auto and Tractor Shop
BOOK DEPARTMENT



If you have never learned by actual experience just how good **Pioneer Shaft Ends** are, do it now by ordering a few of your jobber, and don't let him pawn off on you the "just-as-good," "may suit" brand. Look for the Pioneer trade-mark on the wrappers. Possibly you order a certain kind of horse nails and shoes because they are better and please. So why not specify **Pioneer Shaft Ends** for the same reason? Once you get acquainted, they will be your affinity ever afterwards.

Pioneer Shaft Ends are the kind that are easy to fit, and make the strongest joint.

THREE SIZES:—BUGGY, SURREY AND LIGHT BUGGY.

Made by **CRANDAL, STONE & COMPANY, BINGHAMTON, N. Y.**

"GET-A-WITTE"

BUY ON YOUR OWN TERMS

KEROSENE ENGINE
DIRECT FROM FACTORY—FACTORY PRICES.

Own your farm or shop power at lowest cost. Get as much power for half the price, using kerosene. Choose your own terms—Cash, Payments, or No Money Down as arranged for. Save \$15 to \$200 buying direct—all fully explained in my new book—sent FREE on request.—Ed. H. Witte, Pres.



WITTE Engines
Stationary—Portable—Saw-Rig

are all made in the largest exclusive engine factory in the world dealing direct with user. My Free Factory Book, "How To Judge Engines", tells the whole story—tells why I can make a better engine and sell it for less. No need to pay higher prices than I ask to get the kind of an engine you want, or accept an "old style" or "back-number" to save money. Write for my new illustrated factory book and see just what a big offer I am able to make.

Witte Engine Works
1763 Oakland Ave. Kansas City, Mo.
1763 Empire Bldg. Pittsburgh, Pa.

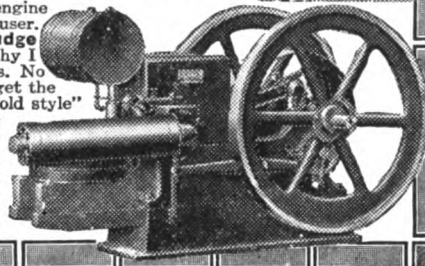

"MARVEL" Forge Blowers

This cut shows you the **RING OIL BEARING** design and construction of the motors used in our "ONE FIRE" \$38.00 **MARVEL** Blowers.

Note the large oil rings which revolve with the **CASE HARDENED** shaft, keeping it running in a perfect bath of oil on the bearings. Perfect Lubrication means long life.

Shipped on 30 days trial through your dealer.

Electric Blower Co.
Boston, Mass.

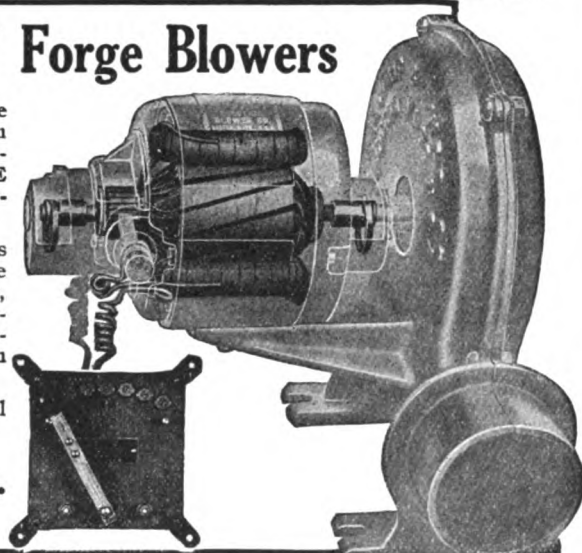

ACCESSORIES AND SUPPLIES OF INTEREST TO THE TRADE.

(Continued from Page 42.)

This machine—a wheel compressor is a hand operated machine and is the invention of a man who worked in a shop and

part of his work was repairing automobile wheels.

Any mechanic who has anything to do with broken or loose automobile wheels knows that it is some job to put in new spokes and make other wheel repairs with ordinary shop tools.

Having this in mind the inventor per-

HAVANA STEEL WHEELS



For your Farm Wagon, so as to make it a Low-Down, instead of having to do your work over the sides of a high wheeled wagon. No dry, loose wheels. More and easier work done. Send postal for free catalog of Steel Wheels and Farm Trucks.

HAVANA METAL WHEEL CO.,
Box 85 Havana, Ill.

fectured the **UNIVERSAL WHEEL COMPRESSOR**. The primary objects of this invention are to provide a mechanism which is adjustable for all types of auto and truck wheels, and so constructed that



repair work may be done speedily. Wheels can be given their desired dish and each spoke can be pressed separately. The rim can be pressed on in a few minutes with out the use of ordinary clamps, which many times cause trouble.

This machine fills a long felt want. It is strong enough to compress heavy truck wheels. With its use it is a simple matter to cut down spokes, putting on new rims, there by making standard size wheels. No power is necessary to operate except your hands. The company issues a circular which should be in the hands of every interested person.

(Continued on Page 46.)

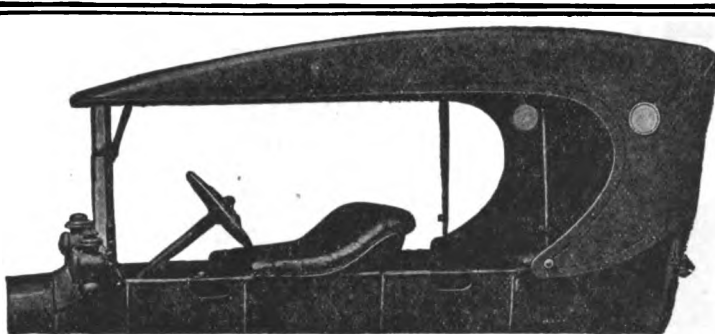

**This Style Top Attracted Your Attention
It Will Also Attract Others**

Our Semi-Victoria Top for Fords, complete with Side Curtains, \$34.35 and up.
Auto Top Coverings, \$7.45 and up.
Ford Auto Tops, complete \$27.60 and up.
Other make Touring Car Tops, \$45.35 and up.

Auto Tops, Seat Covers, Fenders, Radiator Covers and all Trimming Accessories.

Get Our Latest Catalog
Sent Upon Your Request.

**Buob & Scheu, 350-360 Webster Street
CINCINNATI, OHIO**

Let the **WILLIS WELDER** Do Your Work



With this oxy-acetylene worker you can cinch trade in your neighborhood that your competitor cannot get.

More Work, better Results, more satisfied customers, **More Money.** Does that sound good to you?

Get our catalog and let us prove some of the results of proper welding.

If your Dealer cannot supply you, we can. Write direct.

**HENDERSON-WILLIS
Welding & Cutting Company
11th and North Market Streets
ST. LOUIS, MISSOURI, U. S. A.**

**PARK'S
WAGON SHOP
SPECIAL
CIRCULAR RIP and
CROSS-CUT SAW**

22" Bandsaw, 6" Jointer
Tilting Guide, Rim Rounder,
Felloe Borer, Spoke Tenoner,
*All Ready for Instant
Use
No Changing*

Made in two sizes. Will be sent on trial anywhere in U. S. or Canada. Write for catalog today. Don't put it off.

**Park's Ball Bearing
Machine Company
4100 Fergus Cincinnati, O.**

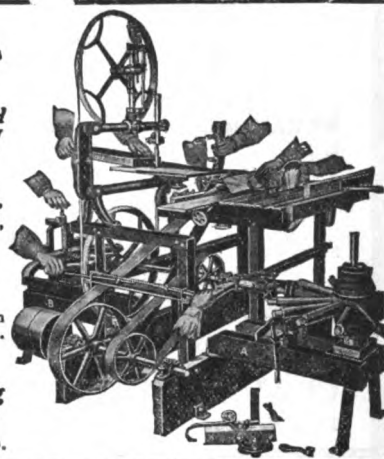

Service Bureau

*Maintained for the Benefit of
Readers of*

AMERICAN BLACKSMITH, AUTO & TRACTOR SHOP

The requirements of our readers are many and diversified. The volume of inquiries reaching the editorial office in each mail has become so great that it has become necessary to enlarge our service department for attending to the correspondence which these inquiries make necessary.

This department is willing and prepared to give its most efficient attention to any letters which may be addressed to it. Perhaps there is some article you may want to buy, some accessory, attachment or device for which a reader may be searching. Make your wants known to the SERVICE BUREAU of the AMERICAN BLACKSMITH, AUTO & TRACTOR SHOP. It will be our pleasure to promptly reply to each and every letter.

Our ability to give prompt service will be increased if the following blank is used. Check any article or articles included in the list—sign your name and address and mail as directed.

Inquiries concerning the operation of automobiles, tractors, motorboats, motorcycles, gas engines or any kind of mechanical or power problems should also be addressed to this department or to the editor direct.

American Blacksmith, Auto & Tractor Shop Service Bureau, Buffalo, N. Y.

GENTLEMEN: I am interested in the following articles which I have checked and would like best prices and complete information.

| | | | | | |
|--------------------|--------------------------|----------------|--------------------|------------------|-------------------|
| Automobiles | Storage Batteries | Engines | Blacksmiths | Machinery | Hand Tools |
| Passenger | Battery Chargers | Gas | Anvils | Lathes | Taps |
| Commercial | Vulcanizers | Gasoline | Tools | Drills | Dies |
| Trailers | Tractors | Kerosene | Forges | Grinders | Wrenches |
| Truck Units | Horse | Motors | Blowers | Band Saws | Rasps |
| Tires | Shoes | Marine | Paints | Woodworking | Tongs |
| Parts | Nails | Electric | Varnishes | Shears | Nippers |
| Oils | Calks | Rowboat | Welding Outfits | Punches | Reamers |
| Magnetos | Pads | | Brasing Outfits | Power Hammers | Vises |
| Generators | | | | | |

Write name of any article not listed above on margin of coupon.

NAME _____
POST OFFICE _____ R. F. D. _____ STATE _____

Are you interested in securing the agency for any make of automobile, truck or tractor? If so state name of article.

FREE

512 Pages of Bargains

Post Paid



FREE

WE WANT to SEND YOU THIS 512 PAGE MONEY MAKING BOOK

It is our New Net Price Catalog for Blacksmiths, Wagonmakers, Horseshoers, and Automobile Repairmen. It contains thousands of articles you can use in your business and thousands you can sell to your trade on which you can make good money; 3,000 illustrations. Tells how you can work up a profitable auto supply and repair business. Serves as a price guide on all supplies for blacksmith, carriage and wagonmaker, horseshoer, and auto repair man. It is a book that will save you money on anything you need in your shop and make you money on the thousands of things you can sell to your trade. Write for your copy today, sending business card, letterhead or some other evidence that you are in the trade.

CRAY BROTHERS, 1113 W. 11th Street,
CARRIAGE HARDWARE AND AUTO ACCESSORIES, Cleveland, Ohio, U. S. A.

"First Made in America."

Hay-Budden Solid Forged Anvils

HAY-BUDDEN MFG. CO., Brooklyn, N. Y.



200,000 IN USE.

Entire top being in one piece of high-grade forged steel, makes a loose face impossible.

Widest Opening

The Wagner & Lowe Hoof Nippers are drop-forged from the best tool steel, hand tempered and hand finished throughout.



Horseshoers who have used them use no others.

For sale by all leading Jobbers

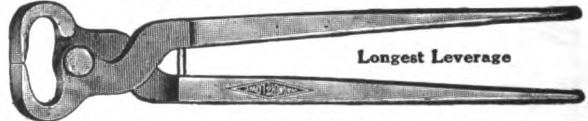

Longest Leverage

The Lowe Manufacturing Co., Enderlin, N. Dak.

ACCESSORIES AND SUPPLIES OF INTEREST TO THE TRADE.

(Continued from Page 44.)

The S. D. Hartog Mfg. Co., of St. Louis Mo., are manufacturers of Tell-Tale Quality Products. The products of importance are the Tell-Tale Piston Ring—Tell-Tale Valve Facing and reseating tools.

The piston ring is made of the best quality, is of one piece, and is so constructed that it will adjust itself to the form of the cylinder. It will stand high heat temperature as it is oil cooled.

Their other product—the Valve facer is a simple contrivance by which the valve can be refaced and made to fit perfectly.



The other tool—The Valve Seater is also simple in construction and is made to do its work properly. With the use of the seater and the facer a perfect fit can be had free from leakage.

In both of these tools the cutters when worn down can be removed and new cut-

ters replaced for a few cuts—The company has circulars which they will mail to any interested person free of charge.

FREE AIR

The Curtis Pneumatic Machinery Co., advertise in this issue a line of Air Compressors. Their claim that all air compressed in a Curtis is free from oil should be of interest both to the autoist and the repair man. An air compressor is a handy thing in the garage, it saves much time and serves a way to build up your business. The autoist when he finds out that the air he gets at your garage is portance are the Tell-Tail Piston Ring—customer of the free air—but here is where your extra business possibilities come in. There will come a time when

he will remember the garage with the sign **FREE—CURTIS AIR—FREE FROM OIL**—This sign is furnished free with every **CURTIS AIR COMPRESSER**—and cannot be had in any other way. The sign is 10x14 inches—baked enamel on steel.

Gasoline and Kerosene Carburetors, construction, installation, adjustment, Victor W. Page, 89 illustrations, 320 pages, \$1.50 postpaid.

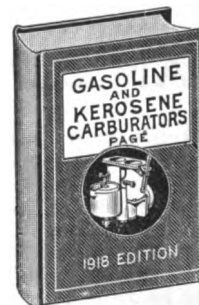

This is a simple, comprehensive and authoritative treatise for practical men explaining all the basic principles pertaining to carburetion, show how liquid fuels are turned into gas for operating all kinds and types of internal combustion engines intended to operate on vapors of gasoline, kerosene, benzol and

alcohol. All leading types of carburetors are described in detail, special attention being given to the forms devised for the cheaper fuels such as kerosene. Carburetor troubles, fuel system troubles; carburetor repairs and installation, electric primers and economizers, hot spot manifolds and all modern carburetor developments are considered in a thorough manner. Methods of adjusting all types of carburetors are fully discussed as well as suggestions for securing maximum fuel economy and obtaining highest engine power.

This book is invaluable to the repairman, students and motorists, as it includes the most complete exposition on kerosene carburetors ever published. The drawings showing carburetor construction are made from accurate engineering designs and show all parts of late types of carburetors.

NOT ONLY A CONVENIENCE but a necessity.

It is for that reason that you should include EKERN'S RUNNING BOARD LUGGAGE CARRIER in your stock.

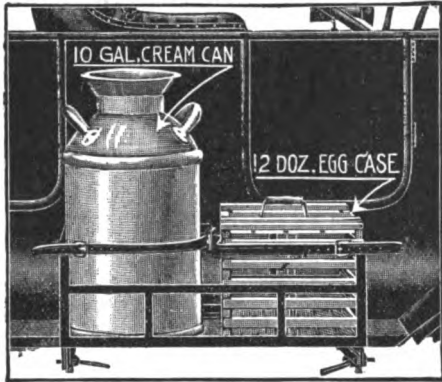

You can easily see why you will be able to sell EKERN'S CARRIER—Packages such as suit cases, milk cans, egg cases and other products of the farm can be carried without injury to the car.

When not in use the carrier can be removed quickly.

The carrier can be clamped to the running board of any make of car and on either side of the car in a minute.

We have other auto accessories which you will be interested in.

Write for Catalog.



1412-1414 So. Michigan Boulevard, Chicago, Ill.

YOU

Can easily prove to your own satisfaction that a set of
BUTTERFIELDS
Combination Auto Screw Plates



is the most economical thread cutting outfit you could possibly buy.

Ask your nearest Dealer and at the same time write for a copy of our new Catalog No. 17.

Butterfield & Co., Inc.

DERBY LINE, VT.,

U. S. A.

LINDE OXYGEN

From Coast to Coast 65 Producing Plants and Distributing Stations provide an unlimited supply of Linde Oxygen for users everywhere.

LINDE SERVICE means no investment except for oxygen actually received—no expensive overhead or upkeep charges.

Linde Oxygen may be obtained from any of the following Linde Plants and Distributing Stations where a large supply of charged 100 and 200 cu. ft. cylinders is kept on hand constantly to insure immediate shipments.

Mail or telephone your order to THE LINDE AIR PRODUCTS CO., at the nearest point. Shipments will be made on day order is received.

Distributing Stations

- Alabama**
 - *Birmingham
10th Ave. & 28th St.
- California**
 - *Emeryville, Oakland
 - *Los Angeles
1405 Mission Road
- Colorado**
 - Denver
1017 17th St.
- Connecticut**
 - Hartford
1095 Main St.
- District of Columbia**
 - Washington
9th & Maryland Ave., S. W.
- Georgia**
 - *Atlanta
Plyant St. & Southern R. R.
 - Savannah
Ogeechee Canal, So. of Bay St.
- Illinois**
 - *Chicago
8688 Wall St.
East St. Louis
6th & Walnut Ave.
 - Peoria, Ill.
721-731 So. Washington St.
- Indiana**
 - *East Chicago
S. E. Cor. Kennedy & 145th Street
 - Fort Wayne
414 E. Columbia St.
 - *Indianapolis
2819 Roosevelt Ave.
- Iowa**
 - Davenport
118 Harrison Street.
 - Des Moines
117 W. 5th Street
- Kansas**
 - Wichita
Rock Island Ave. & 2nd St.
- Kentucky**
 - Louisville
126 E. Main St.
- Louisiana**
 - New Orleans
861 Fulton St.
- Maryland**
 - *Baltimore
25th & Montebello Ave.
- Massachusetts**
 - Cambridge
25 Waverly St.
 - Springfield
Napier St.
 - *Worcester
961 Southbridge St.
- Michigan**
 - *Detroit
St. Aubin Ave. & Newton St.
 - Grand Rapids
Pearl St. by the Bridge
- Minnesota**
 - Duluth
Seventh Ave. West
 - *Minneapolis
1809 Hennepin Ave.
- Missouri**
 - *No. Kansas City
14th & Charlotte St.
 - *St. Louis
4218 Forest Park Blvd.
- Nebraska**
 - Omaha
1007 Jones St.
- New Jersey**
 - *Elizabeth
Linden Ave.
- Newark**
 - 854 Plane St.
- New York**
 - Albany
Montgomery & Colonie Sta.
 - *Brooklyn
475 Driggs Ave.
 - *Buffalo
Broadway & Ideal Sta.
 - New York City
217 W. 29th St.
 - New York City (Bronx)
8168 Park Ave.
 - *Utica
Walnut & Schuyler Sts.
- Ohio**
 - *Cleveland
802 East 72nd Street
 - *Cincinnati
Stanton & Mellish Aves.
 - Columbus
810 Dublin Ave.
 - Dayton
521 E. First St.
 - Lima
838 East High St.
 - Toledo
441 S. Erie St.
 - *Youngstown
601-621 Jones Street
- Oklahoma**
 - Oklahoma City
27 E. Grand Ave.
 - Tulsa
1 North Boulder St.
- Oregon**
 - Portland
15th & Hoyt Sta.
- Pennsylvania**
 - Allentown
211 Gordon St.
 - Erie
1502 Sasfras St.
 - *Norristown
*No. Philadelphia
18th & Cambria Sts.
 - Pittsburgh
16th & Pike Sts.
 - *Trafford
- Tennessee**
 - Chattanooga
212 to 238 King St.
 - Memphis
203 Washington St.
- Texas**
 - *Dallas
Harwood & Coombs St.
 - Houston
Cedar & Baker Sts.
 - San Antonio
513 Dolorosa St.
- Utah**
 - Salt Lake City
112 W. Second St. South
- Virginia**
 - Norfolk
22nd St. & Colonial Ave.
 - Richmond
1709 E. Carey St.
- Washington**
 - Seattle
530 First Ave. South
 - Spokane
121-123 S. Madison St.
- Wisconsin**
 - Manitowac
810 Quay St.
 - *Milwaukee
86th St. & National Ave.

(*) designates plants
Other plants and Distributing Stations are planned for other industrial centers throughout the country and will be established as fast as and wherever the local demand for oxygen warrants.

The Linde Air Products Company
Largest Producers of Pure Oxygen in America
Forty-Second St. Building, NEW YORK

**CUMMINGS & EMERSON
BLACKSMITH SUPPLIES**
Send for net price plow goods catalogue.
PEORIA, ILLINOIS

PATENTS **HERBERT JENNER,**
Patent Attorney and Mechanical Expert, 622 F St., Washington, D. C. Established 1883. I make a free examination and report if a patent can be had and exactly what it will cost. Send for circular.

PATENTS
C. L. PARKER
Ex-Member Examining Corps, U. S. Patent Office
Attorney-at-Law and Solicitor of Patents
American and foreign Patents secured. Trade marks registered. Searches made to determine patentability, validity and infringement. Patent Suits conducted.
Pamphlet of instructions sent upon request.
McGill Building WASHINGTON, D. C.

PATENTS
Inventors invited to Write for Information and Particulars.
Highest References. Best Results. Promptness Assured.
WATSON E. COLEMAN
Patent Lawyer
624 F Street N. W., Washington, D. C.



BUSH CAR—FREE
This Five Passenger 37 H. P. car, 116 in. whl. base. All bearings Timken. Deico Ign.—Dynamo Stg. and Ltg. Write at once for my great Free Offer and 48-page catalog. Agents wanted to drive and demonstrate. Territory open. Prompt shipments. Big money. Cars guaranteed or money back. 1919 cars ready.
BUSH Address: J. N. Bush, President, Dept. U-2, MOTOR CO., Bush Temple, Chicago, Illinois

WANTED AND FOR SALE

Want and For Sale advertisements, situations and help wanted, five cents a word. Send cash with order. No charge less than fifty cents. The small cost of these advertisements prevents our investigating and guaranteeing them. WE WILL NOT knowingly accept any but reliable ones.

WANTED—To hear from owner of good Blacksmith Shop for sale. State cash price, description. **D. F. BUSH, Minneapolis, Minn.**

FOR SALE—Automobile, Marine and stationary engines 1 to 100 H. P. Best makes, good condition, very low prices. State your power needs. We take engines in trade. What have you? Magnets, coils, carburetors, mechanical oilers, water pumps, etc. Also car parts of every nature—sacrifice prices. Write about your requirements.
BADGER MOTOR COMPANY, Milwaukee, Wis.

WANTED—Experienced Blacksmith Good Salary Steady work year round. Also Experienced Woodworker wanted. Write
T. J. JUNKIN, Natchez, Miss.

WANTED—A young, stout, single man, blacksmith for all around wagon repairs and plow work. 4 or 5 years experience. Everything with Electric Power. Steady work. Write at once. **JOHN HOCHENAUER, Sta. D., St. Joseph, Mo.**

FOR SALE—Power, General repairing and shoeing shop good business for two men; income for 1918, \$6700.00. Takes \$4000.00 to handle. **H. F. KRAHMER, Box 136, Gaston, Oregon.**

FOR SALE—The only shop in a good town with large territory. Electric power good equipment, plenty work and top prices, for price and particulars write or come and see
L. J. MILLER, GERMANIA, Ia.

FOR SALE OR TRADE—A set of clock and watchmakers tools will invoice about \$300.00. Could use screw cutting lathe, acetylene welding machine or automobile.
CARMEN BLACKSMITH SHOP, Carmen Okla.

FOR SALE—Like new, Garden City Positive Blower; and 20 inch exhaust fan.
ROY W. ADAMS, Box 403, Mason, Mich.

Pat. Oct. 19, 1909.

Use These Self Sharpening Toe Calks

Ludvigsen Bros. Welded Steel Center Calks are the choice of MANY horseshoers because they always give satisfaction.

THE HARD STEEL PLATE in the center and the two outside plates are welded together and shaped to a sharp calk that stays SHARP while it WEARS DOWN.

Sizes, 0 to 7.

We will gladly mail a sample of this calk to any reader of The American Blacksmith on request. BE SURE TO TELL YOUR JOBBER you want LUDVIGSEN BROS. WELDED STEEL CENTER TOE CALKS.

**LUDVIGSEN BROS.,
JACKSON, MINN.,
or 47 Second St., MILWAUKEE, WIS.**

Wanted—1 fire, electric forge blower, slate maker, state condition and price. Address
THEO. GRANTTIT, Reading, Pa.

BLACKSMITHS LISTEN: Save time and money by doing your own auto and tractor blacksmithing with Toy's modern methods doing hard jobs easy. Forging and making solid welds, hardening and tempering to a standard, with colored tempering charts. All for one dollar. Samples free. **W. M. TOY, Sidney, Ohio.**

FOR SALE—Little Giant Trip Hammer, 50 pound. No. 2 Scientific Cold Tire Setter, 4 H. P. Engine, Little Wonder Disc Sharpener, Emery Grinder, Line Shaft and Pulleys. Address **THEO. DIEKEMPEE, New Baden, Ill.**

A SNAP—Blacksmith wood shops, with fine 7 room house—water—fruit—barn—chicken houses and pens—garage, etc. \$1950.00 Implements if wanted. \$35,000 high school in town. **MCLEOD BRAUN, Denison, Kansas.**

FOR SALE—New Mayer Bros. Trip Hammer 50 lb. size. Snap. Prices on request.
ELLENDALE TOOL CO., Ellendale, Minn.

FOR SALE—Little Giant Trip Hammer 50 lb. head, good condition, for particulars write. **W. C. ZIMMERMAN, Inman, McPherson County, Kansas.**

1919 Model—The L. S. P. Calking Machine

The Greatest Time and Labor Saving Machine on Earth

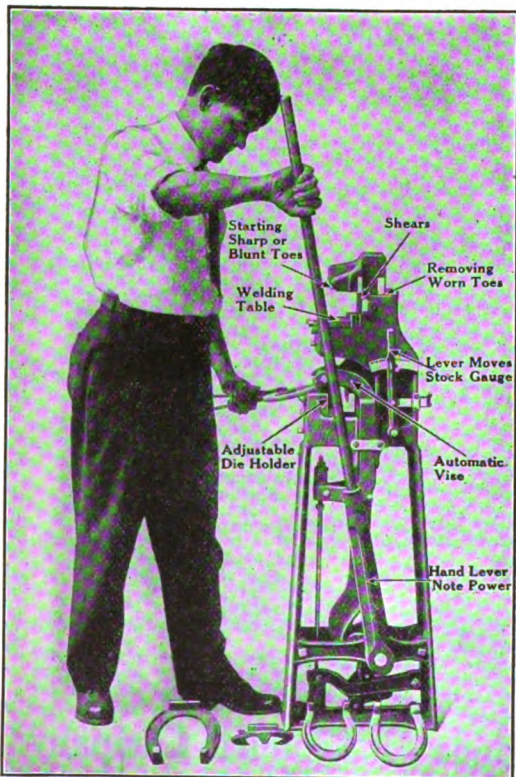

1919 MODEL
Fully covered with Patents

OUR 1919 Model is the same as our 1918. We agree with the users and so would you that it can not be improved.

Do not mistake this for a machine which makes toe calks or a foot vice. This machine is for turning heel calks, both Blunt and Sharp, sticking and welding toe calks, clipping and trimming ends of shoes. IT CALKS SHOES, doing the work just the same as you do by hand with the hammer, only it is done much better and easier, and in a fraction of the time.

In turning heels, you can turn up just as much stock as you wish, upset or stoveup to make as heavy as you like and square up the calks without use of hammer. There is no losing of toes when you weld on the L. S. P.

It is a strong, handsome, well-made machine, and will last, as you might say, a life time, fully warranted for one year. It is in use in the best shops in the United States, users claiming more for it than we do. Write at once for full information and prices.

L. S. P. CALKING MACHINE COMPANY
Peoples' State Bank Building
Wyalusing, Pa., U. S. A.
National Machine Co.,
Brighton, Ont., Canada

ABSORBINE
TRADE MARK REG. U.S. PAT. OFF.

will reduce inflamed, swollen Joints, Sprains, Bruises, Soft Bunches; Heals Boils, Poll Evil, Quittor, Fistula and infected sores quickly as it is a positive antiseptic and germicide. Pleasant to use; does not blister or remove the hair, and you can work the horse. \$2.50 per bottle, delivered. Book 7 R free.

ABSORBINE, JR., the antiseptic liniment for mankind, reduces Painful, Swollen Veins, Wens, Strains, Bruises; stops pain and inflammation. Price \$1.25 per bottle at dealers or delivered. Will tell you more if you write. Liberal Trial Bottle for 10c in stamps.
W. F. YOUNG, P. D. F., 230 Temple St., Springfield, Mass.

ACCESSORIES AND SUPPLIES OF INTEREST TO THE TRADE.

A CATALOGUE YOU NEED

The firm of Buob & Scheu, Cincinnati, Ohio are sending copies of their latest catalogue to interested persons. A post card will bring you a copy of it too, and this catalogue is not only something you need in four business but is a book that

(Continued on Page 44.)

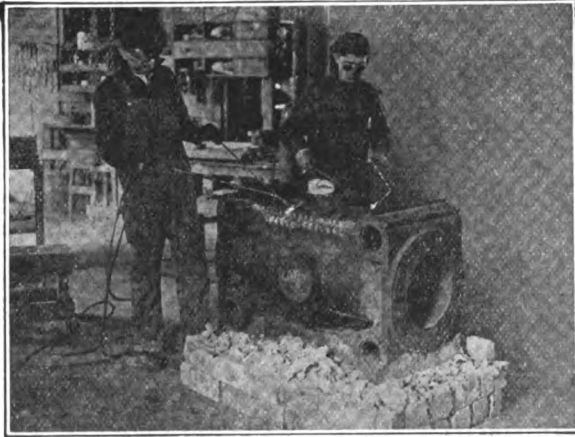

“SAVE THE PIECES!”

“All the King’s horses and all the King’s men couldn’t put Humpty-Dumpty together again.”

It’s a “One-man” job to restore broken or cracked metal parts to their original value and usefulness with Economy Welding and Cutting Outfits and Economy Acetylene Gas Generators

MAKE YOUR OWN ACETYLENE

Using the Economy Acetylene Gas Generator you can make your own acetylene gas; make more of it, for less money, and with no freight or hauling charges. UNCLE SAM needs the acetone in compressed acetylene—needs it bad—needs all he can get. Economy Acetylene Gas Generators do not require acetone.

Write for prices and catalogues to

Economy Welding Machine Company

213 Southwest Boulevard, KANSAS CITY, MO.
Manufacturers of Welder’s supplies and equipment of all kinds.



LITTLE GIANT

Power Hammers

25, 50, 100, 250 and 500lb Models.

BELT or MOTOR DRIVEN



Motor Driven

Belt Driven

The Boys in Khaki and Sailor Blue will be The Farmers of the Euture

Their war equipment has been the most modern and when they return home the old out-of-date methods will no longer satisfy them.

They will insist on their farm equipment being kept in first-class repair and they will take their work to the blacksmith who has up-to-date shop equipment.

No blacksmith shop is modern unless it has a Little Giant Power Hammer. Either of our models will pay for itself in a few months on our easy payment terms, and continue to repay for itself for many years after.

The first Little Giant Power Hammer made 26 years ago and every one since sold,—some 8000 in

all,—are still in use. There is no wearout to them.

Average annual repair sales on all Little Giant Power Hammers in use, large and small, from oldest to latest, is 48c each or less than 2-5 of 1% of original cost to user.

Any Belt Driven Little Giant Power Hammer can be quickly changed to a Motor Driven outfit.

Ask your power plant superintendent for current, voltage phase and cycles of motor required, send this information to us and we will quote prices.

Little Giant Power Hammers are guaranteed FOREVER against defective material and workmanship, and are shipped on 30 days trial. Write your jobber or direct to us.

LITTLE GIANT COMPANY,
Established 1876

101 Mankota, Minnesota
Rock St. U. S. A.

Finished Buggy Shafts
\$10.00 Per Bundle of 6 Pairs

Oak Wagon Spokes
\$3.65 Per Set and Up

Plain Hickory Rims
\$2.15 Per Set and Up

Auto Top Re-Covers
\$8.20 and Up, Parcels Post Paid

30 x 3 1/2 NON SKID
Other Sizes in Proportion \$14.75

WHEEL TOP & HARDWARE CO.
Dep’t W1 Get our Catalogue Cincinnati, Ohio

Dealers! Garagemen!
Put in a complete, assorted stock of

VULCAN SPRINGS

Link up Spring Service for Your Customers with Vulcan “Spring Service for the Nation”. Write now for our special proposition of assorted stock of quick sellers, with Display Rack, Doorsign, Window Transfers, etc.—Free.

Jenkins Vulcan Spring Co.,
Richmond, Indiana.

Stock Carried at These Branches:
St. Louis, Mo. 1402 Chestnut St.
Minneapolis, Minn. 1024 Hennepin Ave.
Dallas, Texas 209 So. Houston St.
Reading, Pa. 538 Franklin St.
Sumter, S. C. 29 Caldwell St.
Atlanta, Ga. 48 Auburn Ave.

TELL-TALE FACTS Why You Should Use TELL-TALE QUALITY PRODUCTS

The **PISTON RING** is made to fulfill all conditions for a perfect ring—AND IT DOES IT.

It is a ring of **TRUTH** and **MERIT** and judged like a mechanic **BY SERVICE**. This **TELL-TALE PISTON RING** should be included in your stock, as the profits are good.

You can do that Valve Facing and Reseating Job in less time, with less labor and expense if you use the Tell-Tale facer and seater.

The Tell-Tale valve facer and valve seater are the simplest of all tools for this purpose.

With these tools it is possible to make a perfect fit between the valve face and its seat. The successful working of his engine makes and keeps your customers satisfied.

THE TELL-TALE VALVE FACER and SEATER will enable you to do work at at profit.

S. D. HARTOG MFG. CO., 2638 Locust Street, **ST. LOUIS, MO.**

TELL-TALE
TRADE MARK
PISTON RINGS

Give us the name and address of your jobber and we will send booklet which tells how to reface and reseat valves easily and quickly.

SHAFT

If you have never learned by actual experience just how good **Pioneer Shaft Ends** are, do it now by ordering a few of your jobber, and don't let him pawn off on you the "just-as-good," "may suit" brand. Look for the Pioneer trade-mark on the wrappers. Possibly you order a certain kind of horse nails and shoes because they are better and please. So why not specify **Pioneer Shaft Ends** for the same reason? Once you get acquainted, they will be your affinity ever afterwards.

Pioneer Shaft Ends are the kind that are easy to fit, and make the strongest joint. **THREE SIZES:—BUGGY, SURREY AND LIGHT BUGGY.**

Made by **The Brewer-Titchener Corporation,** Cortland N. Y.

"MARVEL" Forge Blowers

This cut shows you the RING OIL BEARING design and construction of the motors used in our "ONE FIRE" \$38.00 MARVEL Blowers.

Note the large oil rings which revolve with the CASE HARDENED shaft, keeping it running in a perfect bath of oil on the bearings. Perfect Lubrication means long life.

Shipped on 30 days trial through your dealer.

Electric Blower Co.
Boston, Mass.

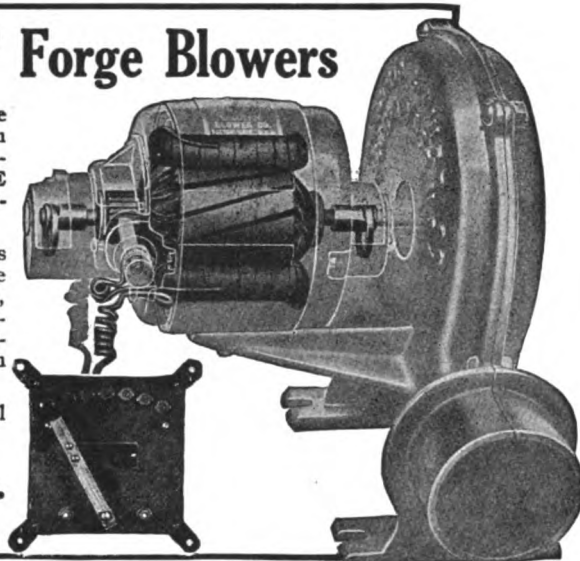

HAVANA STEEL WHEELS

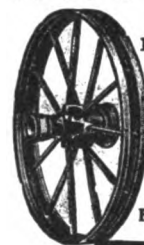

For your Farm Wagon, so as to make it a Low-Down, instead of having to do your work over the sides of a high wheeled wagon. No dry, loose wheels. More and easier work done. Send postal for free catalog of Steel Wheels and Farm Trucks.
HAVANA METAL WHEEL CO.,
Box 85 Havana, Ill.



Learn Auto and Tractor Business

\$100 To \$400 A Month

GREATER opportunities than ever due to increased production of Autos, Trucks, and Tractors. Big demand for Repairmen, Garage Foremen, Drivers and Tractor Operators. Thousands of our graduates making big money.

Learn in 6 to 8 Weeks

Immense additional equipment from our former Military Division. Same practical method as used to train soldier mechanics for U. S. Army in 60-day courses. **Free Now.** Write today, giving age and occupation for 7-Day Trial Offer and 68-page Opportunity Book.
Raha Auto & Tractor School
3154 Oak St., Kansas City, Mo.



ACCESSORIES AND SUPPLIES OF INTEREST TO THE TRADE.

(Continued from page 40)

opens the avenue to excellent profits for yourself and the opportunity to monopolize the business of furnishing new top covers, new seat cushions, etc.

This company manufactures tops to fit any make or model of automobile without measuring or fitting on the part of the purchaser. These tops are made in all styles and materials and their prices mean that you can "bag" a good profit on such orders.

In addition to auto tops and cushions they make complete sets of side and back curtains for all cars in any style and from any material, upholstering materials, radiator and hood covers, curtain lights, plate glass curtain windows that can be applied by anyone, door linings, upholstery and top finishes and dressings, enamels, fenders, tire holders, tool boxes. In addition to this line of accessories and fittings for the motor car this catalogue includes description, illustrations and prices of complete line of buggy makers necessities. such as seats, cushions, storm and side curtains, shaft ends, curtain knobs, hooks, washers, straps, eyelets, bows, dashboards, buggy poles and shafts, etc.

A copy of this catalogue will be mailed to any of our readers on request. Send for it, it's worth money to you.

BIG CUT

In ENGINE PRICES

Not a cut in quality—but a definite money-saving reduction—All sizes—Gasoline, Kerosene, Portable Engines and Saw-Rigs, 2 to 30 H-P. I can sell for less because I make nothing but engines, buy materials for cash, and sell engines direct to users.

IMMEDIATE SHIPMENT

Let me send you my big new catalog and new reduced price list of kerosene and gasoline engines, FREE, postpaid—then you can judge for yourself. Buy NOW on practically your own terms—get your engine at once and save money. 33 years at it proves WITTE quality. My prices prove the saving. Write me today—Get my offer—ED. H. WITTE, Pres.

WITTE ENGINE WORKS
1761 Oakland Avenue, Kansas City, Mo.
1761 Empire Building
Pittsburgh, Pa.

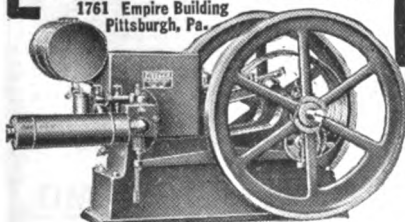

PARO'S SHOP DEVICES

Ekern's Portable Garage Grease Guns

REGISTER AMOUNT OF GREASE OR OIL SOLD

Handles Heaviest Grease as well as Oil

The only Mechanical Hand Operated Gun on the Market.

MODEL K
20 lbs. Grease or 2½ gal. Oil



Order these from your Jobber or write us



Save the Grease, Keep Clean and Make Money

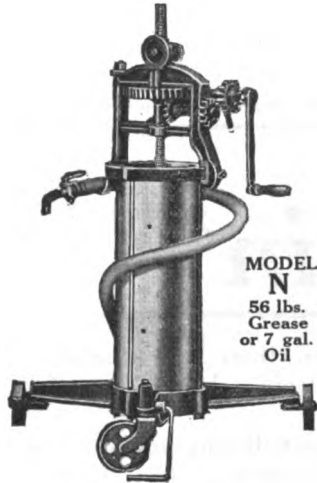

MODEL N
56 lbs. Grease or 7 gal. Oil

1412-14 S. Michigan Blvd. Chicago, Illinois

YOU

Can easily prove to your own satisfaction that a set of **BUTTERFIELDS** Combination Auto Screw Plates



is the most economical thread cutting outfit you could possibly buy.

Ask your nearest Dealer and at the same time write for a copy of our new Catalog No. 17.

Butterfield & Co., Inc.

DERBY LINE, VT.,

U. S. A.

LINDE OXYGEN

From Coast to Coast 65 Producing Plants and Distributing Stations provide an unlimited supply of Linde Oxygen for users everywhere.

LINDE SERVICE means no investment except for oxygen actually received—no expensive overhead or upkeep charges.

Linde Oxygen may be obtained from any of the following Linde Plants and Distributing Stations where a large supply of charged 100 and 200 cu. ft. cylinders is kept on hand constantly to insure immediate shipments.

Mail or telephone your order to THE LINDE AIR PRODUCTS CO., at the nearest point. Shipments will be made on day order is received.

Distributing Stations

- Alabama**
 - *Birmingham 10th Ave. & 28th St.
- California**
 - *Emeryville, Oakland
 - *Los Angeles 1405 Mission Road
- Colorado**
 - Denver 1017 17th St.
- Connecticut**
 - Hartford 1095 Main St.
- District of Columbia**
 - Washington 9th & Maryland Ave., S. W.
- Georgia**
 - *Atlanta Plyant St. & Southern R. R.
 - Savannah Ogeechee Canal, So. of Bay St.
- Illinois**
 - *Chicago 3635 Wall St.
 - East St. Louis 6th & Walnut Ave.
 - Peoria, Ill. 721-731 So. Washington St.
- Indiana**
 - *East Chicago S. E. Cor. Kennedy & 145th Street
 - Fort Wayne 414 E. Columbia St.
 - *Indianapolis 2819 Roosevelt Ave.
- Iowa**
 - Davenport 118 Harrison Street.
 - Des Moines 117 W. 5th Street
- Kansas**
 - Wichita Rock Island Ave. & 2nd St.
- Kentucky**
 - Louisville 126 E Main St.
- Louisiana**
 - New Orleans 861 Fulton St.
- Maryland**
 - *Baltimore 25th & Montebello Ave.
- Massachusetts**
 - Cambridge 25 Waverly St.
 - Springfield Napier St.
 - *Worcester 961 Southbridge St.
- Michigan**
 - *Detroit St. Aubin Ave. & Newton St.
 - Grand Rapids Pearl St. by the Bridge
- Minnesota**
 - Duluth Seventh Ave. West
 - *Minneapolis 1809 Hennepin Ave.
- Missouri**
 - *No. Kansas City 14th & Charlotte St.
 - *St. Louis 4218 Forest Park Blvd.
- Nebraska**
 - Omaha 1007 Jones St.
- New Jersey**
 - *Elizabeth Linden Ave.
- Newark**
 - 354 Plane St.
- New York**
 - Albany Montgomery & Colonie Sts.
 - *Brooklyn 475 Driggs Ave.
 - *Buffalo Broadway & Ideal Sts.
 - New York City 217 W. 29th St.
 - New York City (Bronx) 8168 Park Ave.
 - *Utica Walnut & Schuyler Sts.
- Ohio**
 - *Cleveland 802 East 72nd Street
 - *Cincinnati Stanton & Mellish Aves.
 - Columbus 810 Dublin Ave.
 - Dayton 521 E. First St.
 - Lima 538 East High St.
 - Toledo 441 S. Erie St.
 - *Youngstown 601-621 Jones Street
- Oklahoma**
 - Oklahoma City 27 E Grand Ave.
 - Tulsa 1 North Boulder St.
- Oregon**
 - Portland 15th & Hoyt Sts.
- Pennsylvania**
 - Allentown 211 Gordon St.
 - Erie 1502 Sassafras St.
 - *Norristown *No. Philadelphia 18th & Cambria Sts.
 - Pittsburgh 16th & Pike Sts.
 - *Trafford
- Tennessee**
 - Chattanooga 212 to 238 King St.
 - Memphis 203 Washington St.
- Texas**
 - *Dallas Harwood & Coombs St.
 - Houston Cedar & Baker Sts.
 - San Antonio 512 Dolorosa St.
- Utah**
 - Salt Lake City 112 W. Second St. South
- Virginia**
 - Norfolk 22nd St. & Colonial Ave.
 - Richmond 1709 E. Carey St.
- Washington**
 - Seattle 530 First Ave. South
 - Spokane 121-123 S. Madison St.
- Wisconsin**
 - Manitowac 810 Quay St.
 - *Milwaukee 86th St. & National Ave.

(*) designates plants
Other plants and Distributing Stations are planned for other industrial centers throughout the country and will be established as fast as and wherever the local demand for oxygen warrants.

The Linde Air Products Company
Largest Producers of Pure Oxygen in America
Forty-Second St. Building, NEW YORK

**PARK'S
WAGON SHOP
SPECIAL
CIRCULAR RIP and
CROSS-CUT SAW**

22" Bandsaw, 6" Jointer
Filing Guide, Rim Rounder,
Felloe Borer, Spoke Tenoner.
**All Ready for Instant
Use
No Changing**

Made in two sizes. Will be sent on
trial anywhere in U. S. or Canada.
Write for catalog today.
Don't put it off.

**Park's Ball Bearing
Machine Company**
4100 Fergus Cincinnati, O.

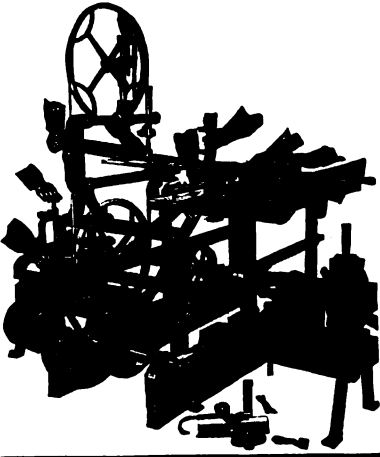

Mr. Smith, Columbus, O.
Everywhere.

If you will watch this space, we will tell
you some mighty interesting things, facts
you will want to know.

Yours truly,
THE COLUMBUS ANVIL & FORGING CO.

“Book Larnin”

FEW if any men know all there is to know about their own particular business.—There's something wrong with the man who “knows it all”—he's either a fool or a most extraordinarily remarkable man.

Among the following list of books our readers will find works that will be of interest and value in increasing your ability and money making power:

| | | | | | |
|--|-------------|--------|---|-------------|------|
| High Speed Steel | (Becker) | \$4.00 | Rogers' Machinist's Guide..... | (Rogers) | 2.00 |
| Steel, Its Selection, Annealing, Hardening and Tempering | | 3.00 | Forge Practice | (Bacon) | 1.50 |
| Hardening, Tempering and Forging of Steel | (Woodworth) | 3.50 | Forging | (Bacon) | 1.00 |
| Tool Making | (Markham) | 1.75 | Forgecraft | (Crowe) | 2.00 |
| Foundry Work | (Stimpson) | 1.00 | Sheet Metal Work | (Neubecker) | 2.00 |
| Drop Forging, Die Sinking and Machine Forming of Steel | | 3.00 | Machine Shop Practice | (Kaupp) | 1.25 |
| Pattern Making | (Ritchey) | 1.50 | Hand Forging and Wrought Iron Ornamental Work | (Googerty) | 1.00 |
| Forging of Iron & Steel | (Richards) | 1.50 | Machine Shop Work | (Turner) | 1.75 |
| Welding | (Hart) | 2.50 | Plain and Ornamental Forging (Schwarzkopf) | | 1.50 |
| | | | Iron and Steel | (Tiemann) | 3.00 |

All books in this list are sent postpaid on receipt of price by the Book Department of the

American Blacksmith, Auto & Tractor Shop BUFFALO, NEW YORK

N. B.—If you don't see what you want in this list, ask about it—we'll get it for you.

ACCESSORIES AND SUPPLIES OF INTEREST TO THE TRADE.

FORD EMERGENCY BRAKES

Almost any man will say that he values his Ford car at considerably more than \$10, and he won't even make an estimate on what he values his own life at. Nevertheless he will unnecessarily risk his life and his car every time he starts out by reason of the fact that the Ford car he drives has insufficient brake equipment.

The Pla-Safe Co., of Brookville, Pa., have produced a successful and eminently satisfactory external brake for Ford cars. Every other car built has such a brake as it is realized that the safety of the occupants of the car depends upon ample braking capacity. The Pla-Safe brake is a large brake and is easily attached to the rear hub drum in less than an hour without drilling or other alteration and is

lined with a superior brake lining and is guaranteed to stop the car and hold the load on any hill.

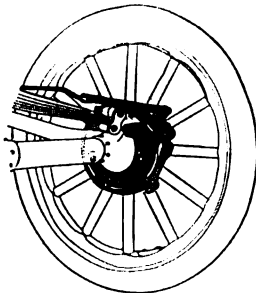

Nine out of ten Ford owners have no emergency brake and depend entirely on their foot brake. If you think this is an exaggeration, try to stop a Ford on a

steep grade by using the Ford emergency brake. Let the car slide down a hill at 20 miles an hour and if you can stop the car and hold the load, we'll treat (butter-milk). Now then, let us presume that an axle, a drive shaft pinion or any of the gears break, either in climbing or descending a hill, then what? Usually a little more work for the undertaker.

The Pla-Safe brake is a necessity to every owner of a Ford car, as the courts have ruled that the driver is personally responsible for anything that may happen to his passengers whether they are carried for profit or for friendship.

The selling arguments for the Pla-Safe brake are so strong and the evidence of the reliability of the brake under all conditions so positive that repairmen and accessory dealers are finding the sale and

Continued on page 40.

What Would You Think of a Manufacturer—

—who wrote to you with a lead pencil—“We are saving much money because we do not use typewriters and telephones?” You might well wonder whether his merchandise was as much out of date as his business methods.

You know that modern time and labor saving appliances are not added expenses, but that they have superseded slower and more costly processes.

The concern which uses your business paper to tell you its business story is simply using a modern piece of selling machinery to make it easier for you to buy intelligently with the least waste of your time and theirs.

For the right kind of advertising shortens the distance between human minds just as certainly as the railroad shortens the distance between places. It is still possible to walk from New York to Chicago, and it is still possible for a business to get along without advertising, BUT—

—bear in mind that the seller who does not advertise does NOT save the cost of advertising, for it costs more to do the work of advertising by other means. Consistent advertisers are progressive merchandisers, and it pays to do business with them.

THE ASSOCIATED BUSINESS PAPERS INC.

The International Association of Trade and Technical Papers
Headquarters, 220 West 42nd St., New York

Motor Age
Motorcycle & Bicycle Illustrated
Motor World
National Builder
National Druggist
National Petroleum News
Nautical Gazette
Northwest Druggist
Power
Power Boating
Power Plant Engineering
Price Current—Grain Reporter
Railway Age
Railway Electrical Engineer
Railway Maintenance Engineer
Railway Mechanical Engineer

Railway Signal Engineer
Retail Lumberman
Rubber Age
Shoe Findings
Shoe and Leather Reporter
Shoe Retailer
Southern Engineer
Southern Hardware & Implement Journal
Sporting Goods Dealer
Starchroom Laundry Journal
Tea and Coffee Trade Journal
Textile World Journal
Timberman
Transfer and Storage
Woodworker

LIST OF MEMBERS

Each has subscribed to and is maintaining the highest standards of practice in their editorial and advertising service.

Advertising and Selling
American Architect
American Blacksmith Auto & Tractor Shop
American Exporter
American Funeral Director
American Hatter
American Machinist
American Paint Journal
American Paint and Oil Dealer
American Printer
American School Board Journal
Architectural Record
Automobile Dealer and Repairer
Automotive Industries
Boot and Shoe Recorder
Brick and Clay Record
Buildings & Building Management
Bulletin of Pharmacy
Canadian Grocer
Canadian Railway & Marine World
Candy and Ice Cream
Chemical and Metallurgical Engineering
Clothier and Furnisher
Coal Age
Coal Trade Journal
Concrete
Cotton
Daily Iron Trade & Metal Market Report
Domestic Engineering
Dry Goods Economist
Drygoodsman
Dry Goods Reporter
Electric Railway Journal
Electrical Merchandising
Electrical Record
Electrical Review
Electrical World
Embalmers' Monthly
Engineering World
Engineering and Mining Journal
Engineering News-Record
Factory
Farm Machinery—Farm Power
Foundry (The)
Furniture Manufacturer & Artisan
Furniture Merchants' Trade Journal
Gas Age
Gas Record
Grand Rapids Furniture Record
Haberdasher
Hardware Age
Heating & Ventilating Magazine
Hide & Leather
Hotel Monthly
Illustrated Milliner
Implement and Tractor Age
Industrial Arts Magazine
Inland Printer
Iron Age
Iron Trade Review
Lumber Trade Journal
Lumber World Record
Manufacturers' Record
Manufacturing Jeweler
Marine Engineering
Marine Review
Metal Worker, Plumber & Steam Fitter
Mining and Scientific Press
Modern Hospital

CUMMINGS & EMERSON
BLACKSMITH SUPPLIES
 Send for net price plow goods catalogue.
 PEORIA, ILLINOIS

PATENTS **HERBERT JENNER**,
 Patent Attorney and Mechanical Expert, 622 F St., Washington, D. C. Established 1883. I make a free examination and report if a patent can be had and exactly what it will cost. Send for circular.

PATENTS

C. L. PARKER
Ex-Member Examining Corps, U. S. Patent Office
Attorney-at-Law and Solicitor of Patents
 American and foreign Patents secured. Trade marks registered. Searches made to determine patentability, validity and infringement. Patent Suits conducted. Pamphlet of instructions sent upon request.
 McGill Building WASHINGTON, D. C.

PATENTS

Inventors Invited to Write for Information and Particulars.
 Highest References. Best Results. Promptness Assured.
WATSON E. COLEMAN
Patent Lawyer
 624 F Street N. W., Washington, D. C.

FODEN'S MECHANICAL TABLES

SAVE ALL FIGURING!

Tell at a glance how much stock to use for oval or elliptical hoops of any size, the circumferences of circles, weight of flat, square and round stock, and the weight and strength of ropes and chains.

Should be in every progressive Smith's hands. Bound very neatly in green cloth. Price, 85c.
AMERICAN BLACKSMITH, AUTO & TRACTOR SHOP
 Buffalo, New York

WANTED AND FOR SALE

Want and For Sale advertisements, situations and help wanted, five cents a word. Send cash with order. No charge less than fifty cents. The small cost of these advertisements prevents our investigating and guaranteeing them. **WE WILL NOT knowingly accept any but reliable ones.**

WANTED—To hear from owner of good Blacksmith Shop for sale. State cash price, description. **D. F. BUSH, Minneapolis, Minn.**

FOR SALE—Automobile, Marine and stationary engines 1 to 100 H. P. Best makes, good condition, very low prices. State your power needs. We take engines in trade. What have you? Magnets, coils, carburetors, mechanical oilers, water pumps, etc. Also car parts of every nature—sacrifice prices. Write about your requirements.
BADGEE MOTOE COMPANY, Milwaukee, Wis.

BLACKSMITHS LISTEN: Save time and money by doing your own auto and tractor blacksmithing with Toy's modern methods doing hard jobs easy. Forging and making solid welds, hardening and tempering to a standard, with colored tempering charts. All for one dollar. Samples free. **W. M. TOY, Sidney, Ohio.**

FOR SALE—The only shop in a good town with large territory. Electric power good equipment, plenty work and top prices, for price and particulars write or come and see **L. J. MILLER, GERMANIA, Ia.**

FOR SALE—Horse shoeing and blacksmith shop in town of 1200, near eastern entrance of Yellowstone National Park, up-to-date electric power machinery. For further particulars, write—**H. H. SCHWOEB, Cody, Wyoming.**

FOR SALE—Blacksmith Shop and 7 acres land in good cultivation, good buildings. Across the Sound from Seattle, Wash.
D. C. CHRISTIE, Colby, Wash.

WANTED—A No. 10½ Little Giant Bolt Threader and Nut Tapper, in good condition.
C. J. HALL, Rosalia, Wash.

WANTED—Good allround blacksmith at once. Young married man preferred.
M. W. ABTS, Morrill, Nebr.

WANTED—A 10 or 12 in, hand jointer, and 25 or 50 lb. power hammer.
C. F. WESTON, Reedsburg, Wis.

FOR SALE—Blacksmith and woodworking shop, oxy-acetylene welding plant, electric light and power plant, Grist Mill in connection. Electric plant consists of one 85 H. P. Boiler Heater and Pump 40-60 H. P. Hamilton Corliss Engine, 40 K. W. A., 2400 Volts Triumph Generator with exciter and switchboard, 9 Transformers on line, about 90 customers with 60 meters in a town of about 800. Alabama Normal College furnished with current, also street light contracts. Franchise for 25 years. Price \$5700, a good investment and a cheap price. Reason for selling, wife not satisfied. Address owner.
GUSTAV KOPPIUS, Livingston, Ala.

FOR SALE—Splendid Blacksmith Business in one of Michigan's best towns. Sickness the cause. Correspond with
F. L. CONVIS, Ithaca, Mich.

FOR SALE—A few rebuilt ROTO Electric Blowers, good as new. One year guarantee. Until sold \$25.00. **THE ROSEWATER ELECTRIC CO., Cleveland, Ohio.**

FOR SALE—Good Blacksmith Shop also can do tractor and Auto work, in a very good town, 2000 population only one other shop in town. Get the best prices in state. Equipped for all kinds of Blacksmith and wood work. Anyone wanting a good shop in the west, please write and I will let you know all about it.
F. R. MILLER, Ordway, Colorado.

FOR SALE—At a Sacrifice — Blacksmith, Horse-Shoeing and wagon Repair Business, fully equipped with large stock, tools and machinery, run by 6 H. P. Gasoline Engine. Steady work for 3 men. Established over twenty years. Selling on account of health.
S. L. LASSER, CALLICOON, N. Y.

WANTED—A partner to take half interest in a well established Blacksmithing Shop fully equipped with modern tools. Want someone to help start a foundry. Good locality for this business. Anyone interested address,
POST OFFICE BOX 208, Basin, Wyoming.

FOR SALE—Well equipped Blacksmith shop, only shop in town, prosperous territory.
F. W. KRUGER, Little Cedar, Iowa.

BLACKSMITH SHOP & TOOLS—12 H. P. Engine 14 in. stone burr, Combination wood worker. Would rent shop. Will exchange any of tools or machinery for a No. 3 Little Giant Hub Borer and a power spoke tenoner and Bokop tire setter and cooler. Write
H. A. LAW, Fairport, Mo.

FARM with your Ford and do 2 days work in 1. Agents make \$100 weekly. Money back guarantee. Write today for free circular.
GENEVA TRACTOR CO., Dept. 8 Geneva, Ohio.

ACCESSORIES AND SUPPLIES OF INTEREST TO THE TRADE.

Continued from page 38

installation of the Pla-Safe brake a veritable Bonanza.

An attractive selling proposition is made by the Pla-Safe Co., and the details, discounts, etc., are yours on request to the Pla-Safe Co., Brookville, Penna.

VULCAN PLANS GREATER PRODUCTION

During a recent interview of T. B. Jenkins, President of Jenkins Vulcan Spring Company, some very interesting facts were disclosed regarding present and future development of Vulcan production.

"We can justly claim the distinction of being the pioneers in the replacement field", said Mr. Jenkins. "Our niche is undeniably an important one in the motor world and is clearly emphasized by the ever increasing demand for reliable replacement springs. Ten years ago probably motorists would have scoffed at such an apparently absurd idea as devoting a business exclusively to springs for replacement purposes. But springs do break and at most unexpected places and with

Continued on page 42.

1919 Model—The L. S. P. Calking Machine

The Greatest Time and Labor Saving Machine on Earth

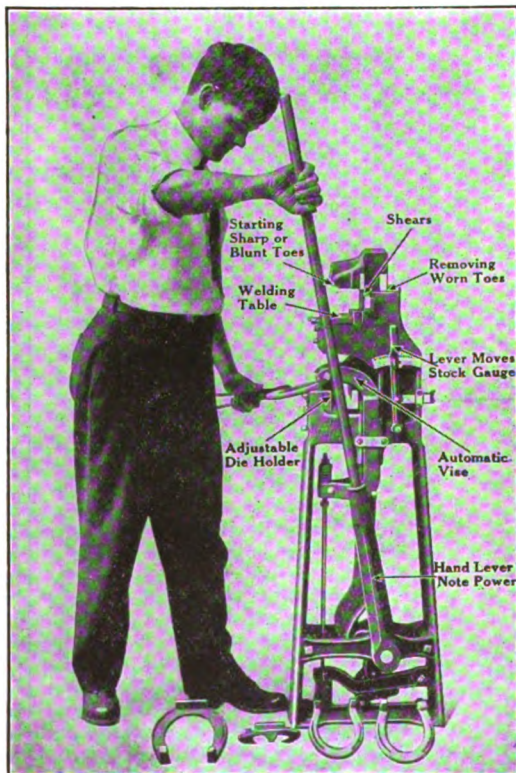

1919 MODEL
 Fully covered with Patents

OUR 1919 Model is the same as our 1918. We agree with the users and so would you that it can not be improved.

Do not mistake this for a machine which makes toe calks or a foot vice. This machine is for turning heel calks, both Blunt and Sharp, sticking and welding toe calks, clipping and trimming ends of shoes. **IT CALKS SHOES**, doing the work just the same as you do by hand with the hammer, only it is done much better and easier, and in a fraction of the time.

In turning heels, you can turn up just as much stock as you wish, upset or stoveup to make as heavy as you like and square up the calks without use of hammer. There is no losing of toes when you weld on the L. S. P.

It is a strong, handsome, well-made machine, and will last, as you might say, a life time, fully warranted for one year. It is in use in the best shops in the United States, users claiming more for it than we do. Write at once for full information and prices.

L. S. P. CALKING MACHINE COMPANY

Peoples' State Bank Building
 Wyalusing, Pa., U. S. A.

National Machine Co.,
 Brighton, Ont., Canada

DEALERS

Alford Auxiliary Spring Attachments will net you a good profit

This SPRING attachment is entirely different from others. While it adds spring tension to permit you to carry a 3/4 ton load it also absorbs the road shocks that the tires and rear axle ordinarily have to stand, and prevents the swinging and tipping of the body, as well as cutting the center bolt of rear spring; which would cause the body to lean to one side.

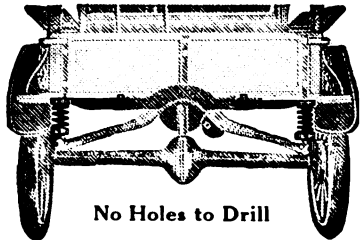

No Holes to Drill

Attachment for Model T Fords, \$16.00

A Quick Seller to all who use Fords for Commercial Purposes

Your locality is full of prospective customers. Every Ford owner is a prospect. It will pay you to investigate this opportunity.

These springs are mechanically perfect and are fully guaranteed.

Agents wanted everywhere—Write today for particulars and literature.

ANDREW HOFFMAN MFG. CO.

5036 So. State Street,

CHICAGO, ILLINOIS

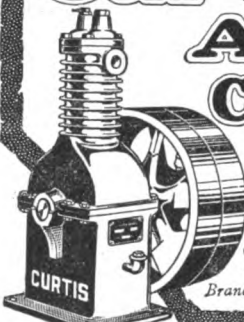

Curtis
Air
Compressors

**FREE
CURTIS-AIR
FREE FROM OIL**

Install a Curtis and furnish your patrons with CURTIS AIR—FREE FROM OIL. The Curtis sign (free with each Curtis Compressor) inspires confidence and helps build your business. Ask your jobber or write us for full information.

Curtis Pneumatic Machinery Co.
1514 Kienlen Ave., St. Louis, Mo.
Branch Office—530-M Hudson Terminal, New York City

With This Machine



Adjust to give any dish desired

Your shop is capable of repairing wheels quickly at reasonable cost and you can depend on obtaining plenty of other automobile work. The **Universal Wheel Compressor** is so constructed that repair work may be done speedily on all types of auto and truck wheels. Wire spoke wheels as easily repaired as wooden ones.

The **compressor** is strong enough to compress the heavy truck wheels.

Write for Information.

Universal Wheel Compressor Co.
Lake St., Cedar Rapids, Iowa.

THE VETERAN HORSESHOER LOOKS BACK UPON **35 YEARS**
OF COMPLETE SATISFACTION WITH THE

BOSS IRON & BANNER STEEL HORSE AND MULE SHOES

and we strive NOW to maintain that standard of quality which marked so plainly the "BOSS" shoe in 1882.

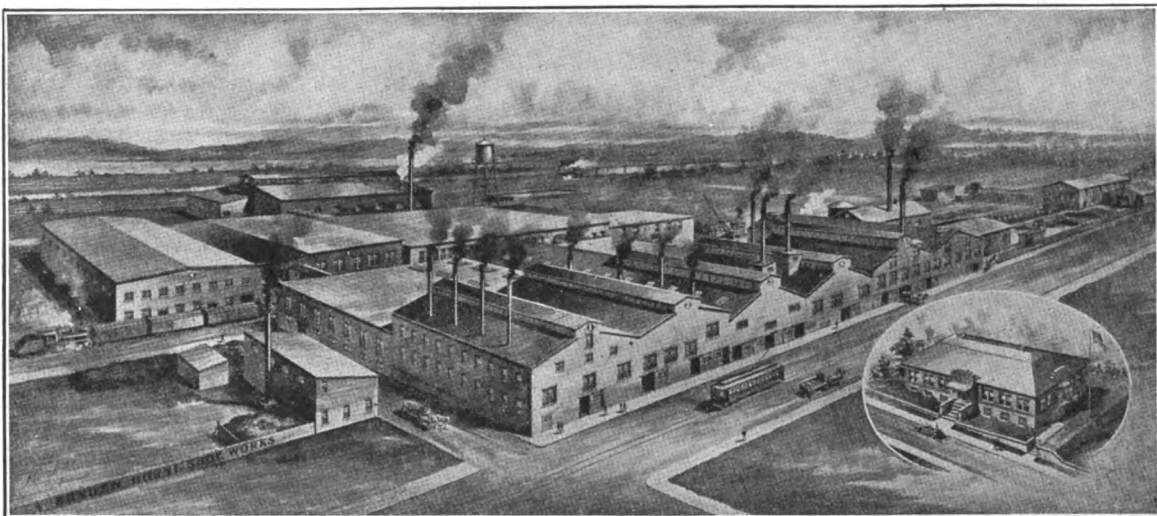

Bryden Horse Shoe Works
Catasauqua, Penna.

SEND FOR DESCRIPTIVE CATALOG.



Pioneer Shaft Ends are, do it now by ordering a few of your jobber, and don't let him pawn off on you the "just-as-good," "may suit" brand. Look for the Pioneer trade-mark on the wrappers. Possibly you order a certain kind of horse nails and shoes because they are better and please. So why not specify **Pioneer Shaft Ends** for the same reason? Once you get acquainted, they will be your affinity ever afterwards.

Pioneer Shaft Ends are the kind that are easy to fit, and make the strongest joint. **THREE SIZES:—BUGGY, SURREY AND LIGHT BUGGY.**

Made by **The Brewer-Titchener Corporation,** Cortland N. Y.

"MARVEL" Forge Blowers

This cut shows you the **RING OIL BEARING** design and construction of the motors used in our "ONE FIRE" \$38.00 **MARVEL** Blowers.

Note the large oil rings which revolve with the **CASE HARDENED** shaft, keeping it running in a perfect bath of oil on the bearings. Perfect Lubrication means long life.

Shipped on 30 days trial through your dealer.

Electric Blower Co.
Boston, Mass.

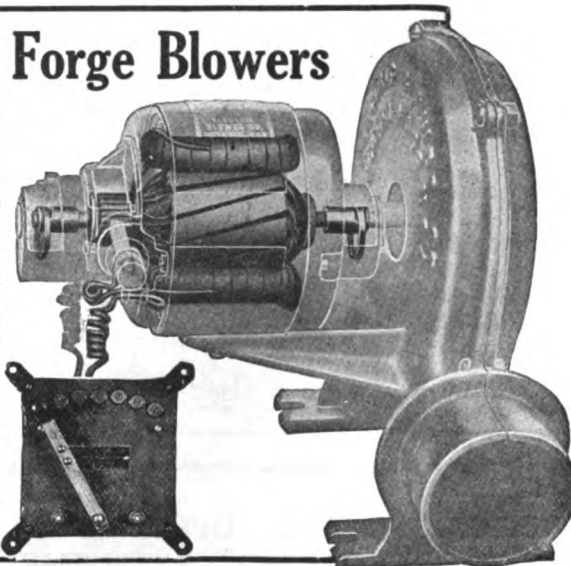

H A V A N A
STEEL WHEELS



For your Farm Wagon, so as to make it a Low-Down, instead of having to do your work over the sides of a high wheeled wagon. No dry, loose wheels. More and easier work done. Send postal for free catalog of Steel Wheels and Farm Trucks.
HAVANA METAL WHEEL CO.,
Box 85 Havana, Ill.

and modern equipment. This building is 350 feet by 350 feet with an area of 125,000 square feet of floor space. When completed, the monthly capacity will be 2,000 tons.

The selling force has not been overlooked by any means, but is being increased in proportion to the production. While the present road organization now consists of twelve men, by June first, this will be increased to twenty-five. The maintenance of six selling branches, with spring experts in charge, besides over 6000 Dealer Agencies throughout the country is further demonstration of the breadth and scope that Vulcan Service represents.

There has been a recent change in the selling force executives at the factory. Mr. W. B. Edwards, formerly in charge of the Sales at Reading, Pa., has been appointed assistant General Sales Manager, with headquarters at Richmond.

If your horse has anything wrong with him, you are naturally looking for something to get him going sound. Have you tried **ABSORBINE**? This remedy has been on the market for over a quarter of a century and is constantly making new friends as well as retaining the old ones.

Mr. W. J. McManemon, South Weymouth, Mass., writes under date of February 12th, 1919; "I became acquainted with **ABSORBINE** in 1898. I have used a great deal of it in the past twenty years and have been helped out of many tough spots by its use."

ABSORBINE does not blister or remove the hair and the horse can be used during treatment. Wind puffs, strains, sprains, bursitis, bog spavin, capped hock, swollen tendons, all are promptly reduced by the use of this valuable remedy which should be in every stable. At druggists \$2.50 per bottle, or sent prepaid upon receipt of price. Special instructions for treatment of your case will be sent upon application. W. F. Young, P. D. F., 230 Temple St., Springfield, Mass.

ACCESSORIES AND SUPPLIES OF INTEREST TO THE TRADE.

Continued from page 40

the millions of cars operating, the demand has compelled us to keep right on growing."

The present Vulcan Plant at Richmond,

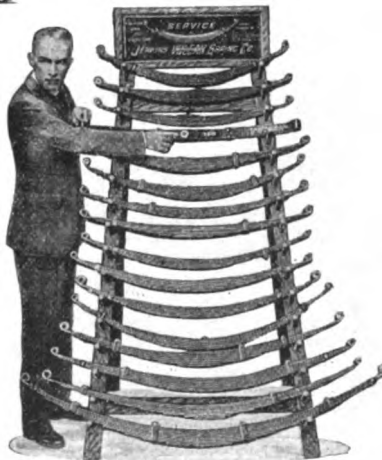

Indiana, has a floor space of 60,000 square feet with a monthly production capacity of 400 tons per month. There is now in course of construction a new concrete and steel plant that is a marvel for efficiency

Get a WITTE

BIG CUT IN ENGINE PRICES



No Cut In Quality

I have made a big smashing reduction in engine prices—for quick shipment—all styles—all sizes—2 to 30 H. P.—Kerosene or Gasoline—Stationary, Portable or Saw-rig—Buy on your own terms. I guarantee safe delivery, make **immediate shipment**—guarantee every part of your engine against defects as long as you use it—no "strings"—no time limit. Write me at once for prices on this special factory direct offer. Book Free.—Ed. H. Witte, Pres.

WITTE ENGINE WORKS
1762 Oakland Ave. - - Kansas City, Mo.
1 62 Empire Bldg. Pittsburgh, Pa.

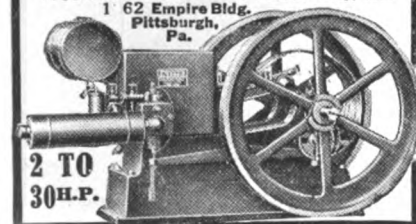

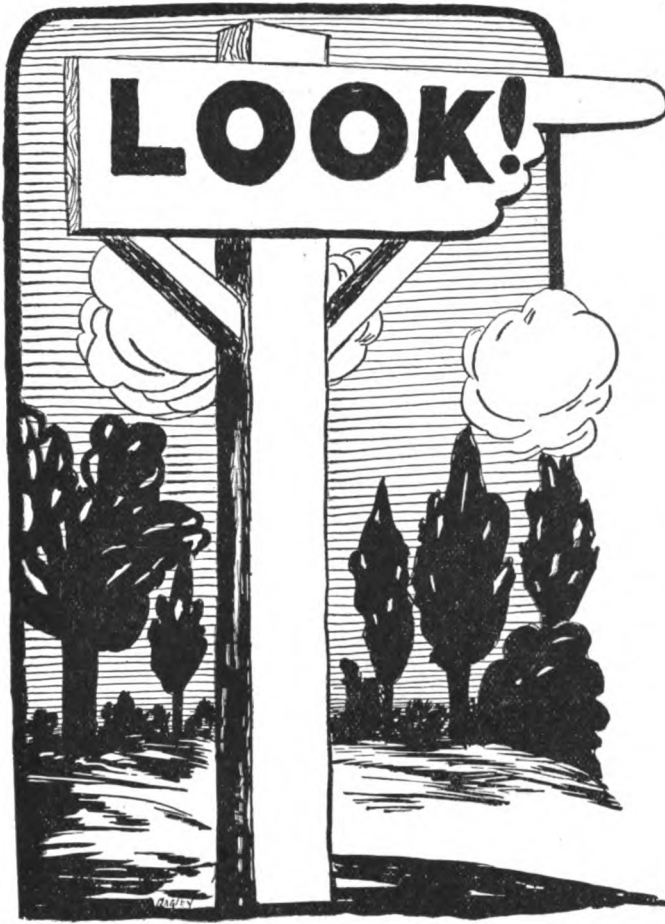

At The Rose Tire Pump

and you will see why it is superior to other pumps. Barrel seamless steel; top and base machined from solid screw stock; patent valve; special tanned cupped leather holding its shape indefinitely.

Brass barrels are easily crushed; top and base of cast iron are unsatisfactory and easily broken; common type of valve construction makes any pump pump hard. Why then buy any but the Rose Tire Pump with the Patent Valve.

1½ Rose Tire Pump - - - - \$3.50
 1¼ Rose Tire Pump - - - - \$3.00

Handled by most Jobbers and Dealers

Manufactured and Guaranteed by

J. H. HANEY & CO.

Hastings,

Nebraska

YOU CAN WELD STEEL AS EASILY AS IRON



Especially adapted for welding tires, axles, springs and all lap welding.

Either of these compounds will weld steel at the lowest possible heat that steel can be welded. Also protects steel at high heat.

Owing to our improved process of manufacturing, these compounds do not boil off and waste in the fire, but adhere to the metal when applied.

FOR SALE BY ALL LEADING DEALERS IN BLACK-SMITH SUPPLIES IN UNITED STATES AND CANADA

Large Free Sample Sent on Request

CORTLAND WELDING COMPOUND CO., Cortland, N. Y.



PREPARED ESPECIALLY FOR WELDING FAR SUPERIOR TO COMMON BORAX

A flux which causes the steel to weld like iron. Not necessary to apply between the lap, but may be applied to the outer surface of the work, the same as borax. Has no equal for plow work. Just the thing for welding toe-calks so they can't knock off.

LOWER PRICES ON WHEELS

Get our new Catalogue No. 61

Wheel Top & Hdw. Co.

Dept. W1,

Cincinnati, Ohio

WRITE TODAY!

A BIG BARGAIN!

You can compete with any auto spring factory with this.

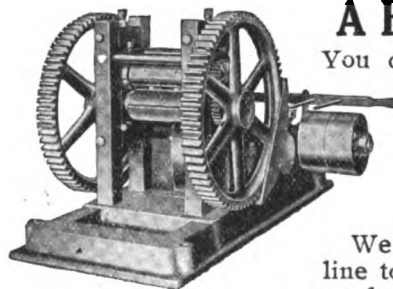

STURGIS SPRING LEAF TAPERING MACHINE.

We are discontinuing this line to make room for other products. **Write Today!**

AXELSON MACHINE CO., Los Angeles, Cal.

PATENTS HERBERT JENNER, Patent Attorney and Mechanical Expert, 622 F St., Washington, D. C. Established 1883. I make a free examination and report if a patent can be had and exactly what it will cost. Send for circular.

PATENTS

C. L. PARKER
Ex-Member Examining Corps, U. S. Patent Office
Attorney-at-Law and Solicitor of Patents
American and foreign Patents secured. Trade marks registered. Searches made to determine patentability, validity and infringement. Patent Suits conducted. Pamphlet of instructions sent upon request.
McGill Building WASHINGTON, D. C.

PATENTS

Inventors Invited to Write for Information and Particulars.
Highest References, Best Results, Promptness Assured.
WATSON E. COLEMAN
Patent Lawyer
624 F Street N. W., Washington, D. C.

Beals McCarthy & Rogers

Blacksmiths and Wagon-
makers Supplies
Motor Car Accessories
Buffalo, N. Y.
Largest Stock in New York State

WANTED AND FOR SALE

Want and For Sale advertisements, situations and help wanted, five cents a word. Send cash with order. No charge less than fifty cents. The small cost of these advertisements prevents our investigating and guaranteeing them. WE WILL NOT knowingly accept any but reliable ones.

WANTED—To hear from owner of good Blacksmith Shop for sale. State cash price, description. D. F. BUSH, Minneapolis, Minn.

FOR SALE—Automobile, Marine and stationary engines 1 to 100 H. P. Best makes, good condition, very low prices. State your power needs. We take engines in trade. What have you? Magnetos, coils, carburetors, mechanical oilers, water pumps, etc. Also car parts of every nature—sacrifice prices. Write about your requirements.
BADGER MOTOR COMPANY, Milwaukee, Wis.

BLACKSMITHS LISTEN: Save time and money by doing your own auto and tractor blacksmithing with Toy's modern methods doing hard jobs easy. Forging and making solid welds, hardening and tempering to a standard with colored tempering charts. All for one dollar. Samples free. W. M. TOY, Sidney, Ohio.

FOR SALE—Blacksmith Shop and 7 acres land in good cultivation, good buildings. Across the Sound from Seattle, Wash.
D. C. CHRISTIE, Colby, Wash.

FOR SALE—Good Blacksmith Shop also can do tractor and Auto work, in a very good town. 2000 population only one other shop in town. Get the best prices in state. Equipped for all kinds of Blacksmith and wood work. Any one wanting a good shop in the west, please write and I will let you know all about it.
F. B. MILLER, Ordway, Colorado.

FOR SALE—At a Sacrifice — Blacksmith Horse-Shoeing and wagon Repair Business fully equipped with large stock, tools and machinery, run by 6 H. P. Gasoline Engine. Steady work for 3 men. Established over twenty years. Selling on account of health.
S. L. LASSER, CALLICOON, N. Y.

CUMMINGS & EMERSON BLACKSMITH SUPPLIES

Send for Catalogue of Automobile Supplies.
PEORIA, ILLINOIS

WANTED—Good allround blacksmith at once. Young married man preferred.
M. W. ABTS, Morrill, Nebr.

FOR SALE—Splendid Blacksmith Business in one of Michigan's best towns. Sickness the cause. Correspond with
F. L. CONVIS, Ithaca, Mich.

ACCESSORIES AND SUPPLIES OF INTEREST TO THE TRADE.

A TOP DRESSING WORTHY OF CON- SIDERATION

West's Automobile Top Dressing needs very little introduction. It has been on the market since 1906.

West's Top Dressing is black and when applied on Auto Tops produces a good surface finish. It does not crack or wash off and dries over night. It can be applied to the cushions and back. It dries quickly and does not rub off.

This Top dressing will not injure the finest top material. It renders all top material water-proof and preserves the life of the top. It covers the worn spots, fills the cracks and leaves a finish like new.

This dressing should be included in every stock of auto accessories. It is a profitable article for the dealer to handle and very profitable for the car owner to use.

You don't have to argue to sell this line, it sells itself. L. M. West's Sons, 230 Broadway, Rockford, Ill., manufacture this product. They will send upon request their literature describing this wonderful dressing. It is worth reading. See their advertisement elsewhere in this issue.

AUTOMOBILE AND WAGON BODY IRONS

How do you work a body job? Do you make your own irons by hand or do you do the wise thing and buy your irons ready to apply to the job at a great saving in time and money that means a considerable addition to the profits of each job.

Before proceeding further we are going to suggest that you write the Eberhard Mfg. Co., of Cleveland, Ohio and ask for their catalogue of body irons which they will be pleased to send you gratis.

The body irons manufactured by this firm are made of the best quality malleable iron and come ready drilled and threaded with nuts, ready to fit to the job at a price that is considerably lower than the cost of your own time required to forge such a set by hand.

Automobile body irons are by no means all that the Eberhard Co., manufacture. They have been in this business for a number of years and manufacture a complete assortment of all manner of wagon and buggy irons for all kinds and sizes of vehicles and no matter whether you merely want one or two irons that you find hard to hammer out or a complete set you can get them and no matter whether it is a small job or a big one you save money by using Emco malleable irons.

Among other articles that the body builder needs that are supplied by the Eberhard Co., are all manner of handles, corner irons, body and chassis connecting irons, jointed lazy back seat irons, auxiliary seat irons, door locks, end gate fasteners, end gate hinges, stake pockets, stake plates, spring couplings, spring

Continued on page 42.

1919 Model—The L. S. P. Calking Machine

The Greatest Time and Labor Saving Machine on Earth

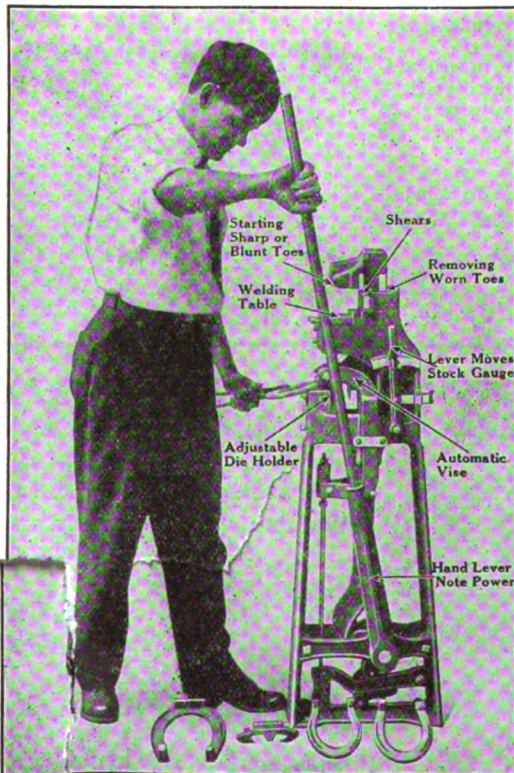

1919 MODEL
Fully covered with Patents

OUR 1919 Model is the same as our 1918. We agree with the users and so would you that it can not be improved.

Do not mistake this for a machine which makes toe calks or a foot vice. This machine is for turning heel calks, both Blunt and Sharp, sticking and welding toe calks, clipping and trimming ends of shoes. IT CALKS SHOES, doing the work just the same as you do by hand with the hammer, only it is done much better and easier, and in a fraction of the time.

In turning heels, you can turn up just as much stock as you wish, upset or stoveup to make as heavy as you like and square up the calks without use of hammer. There is no losing of toes when you weld on the L. S. P.

It is a strong, handsome, well-made machine, and will last, as you might say, a life time, fully warranted for one year. It is in use in the best shops in the United States, users claiming more for it than we do. Write at once for full information and prices.

L. S. P. CALKING MACHINE COMPANY

Peoples' State Bank Building
Wyalusing, Pa., U. S. A.
National Machine Co.,
Brighton, Ont., Canada

SEE THAT SPRING

THIS spring is entirely different from other springs. The **Alford Auxiliary Springs** furnish additional spring tension. They will permit you to carry a $\frac{3}{4}$ ton load and they will absorb the road shocks that the tires and rear axles ordinarily have to stand. It takes from 30 minutes to an hour to install this attachment. These springs are mechanically perfect and are fully guaranteed.

Attachment for
Model T Fords,
\$16.00

PATENTED

This shows the Alford
Auxiliary Spring properly
attached to car.

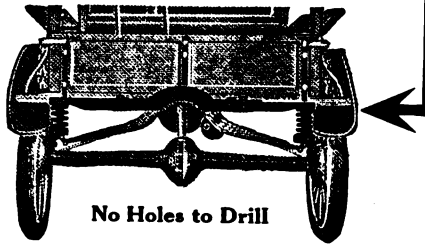

No Holes to Drill

Your locality is full of prospective customers. Every Ford owner is a prospect. It will pay you to investigate this opportunity.

Agents wanted everywhere—Write today for particulars and literature.

ANDREW HOFFMAN MFG. CO.

5036 So. State Street,

CHICAGO, ILLINOIS

Curtis Air Compressors

Install a Curtis and furnish your patrons with CURTIS AIR—FREE FROM OIL. The Curtis sign (free with each Curtis Compressor) inspires confidence and helps build your business. Ask your jobber or write us for full information.

Curtis Pneumatic Machinery Co.
1514 Kienlen Ave., St. Louis, Mo.
Branch Office—530-M Hudson Terminal, New York City

With This Machine



Adjust to give
any dish desired

Your shop is capable of repairing wheels quickly at reasonable cost and you can depend on obtaining plenty of other automobile work. The **Universal Wheel Compressor** is so constructed that repair work may be done speedily on all types of auto and truck wheels. Wire spoke wheels as easily repaired as wooden ones.

The **compressor** is strong enough to compress the heavy truck wheels.

Write for information.

Universal Wheel Compressor Co.
Lake St., Cedar Rapids, Iowa.

THE VETERAN HORSESHOER LOOKS BACK UPON **35 YEARS** OF COMPLETE SATISFACTION WITH THE **BOSS IRON & BANNER STEEL** HORSE AND MULE SHOES

and we strive **NOW** to maintain that standard of quality which marked so plainly the "BOSS" shoe in 1882.

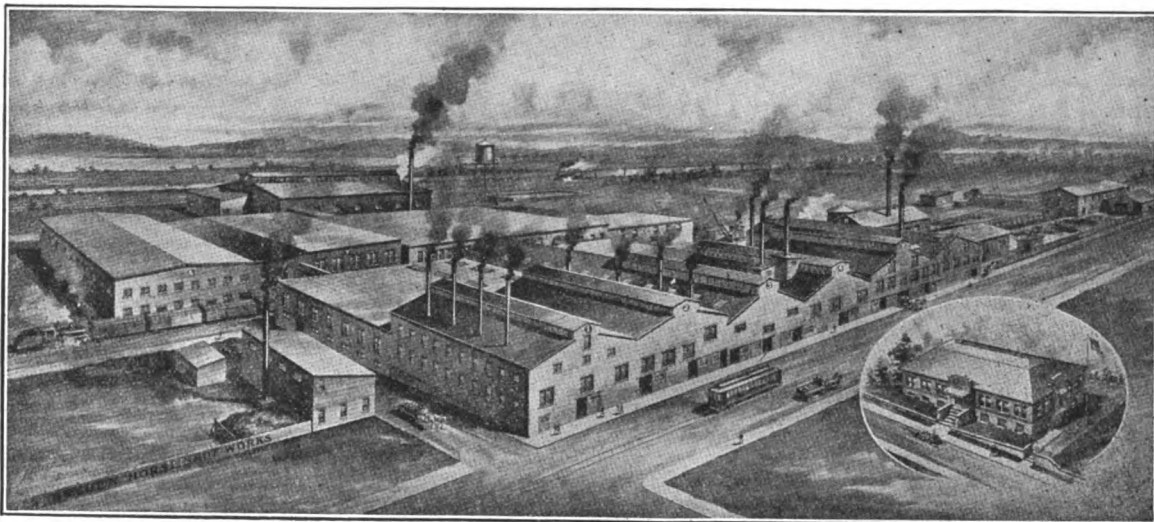

Bryden Horse Shoe Works
Catasauqua, Penna.

SEND FOR DESCRIPTIVE CATALOG.



If you have never learned by actual experience just how good

Pioneer Shaft Ends

are, do it now by ordering a few of your jobber, and don't let him pawn off on you the "just-as-good," "may suit" brand. Look for the Pioneer trade-mark on the wrappers. Possibly you order a certain kind of horse nails and shoes because they are better and please. So why not specify **Pioneer Shaft Ends** for the same reason? Once you get acquainted, they will be your affinity ever afterwards.

Pioneer Shaft Ends are the kind that are easy to fit, and make the strongest joint. **THREE SIZES:—BUGGY, SURREY AND LIGHT BUGGY.**

Made by **The Brewer-Titchener Corporation,**

Cortland N. Y.

"MARVEL" Forge Blowers

This cut shows you the RING OIL BEARING design and construction of the motors used in our "ONE FIRE" \$28.00 MARVEL and and on our No. 23 MARVEL \$25.00 Blowers, the windings being different.

Note the large oil rings which revolve with the CASE HARDENED, shaft keeping it running in a perfect bath of oil on the bearings. Perfect lubrication means long life.

Shipped on 30 days' trial through your dealer.

Electric Blower Co.
Boston, Mass.

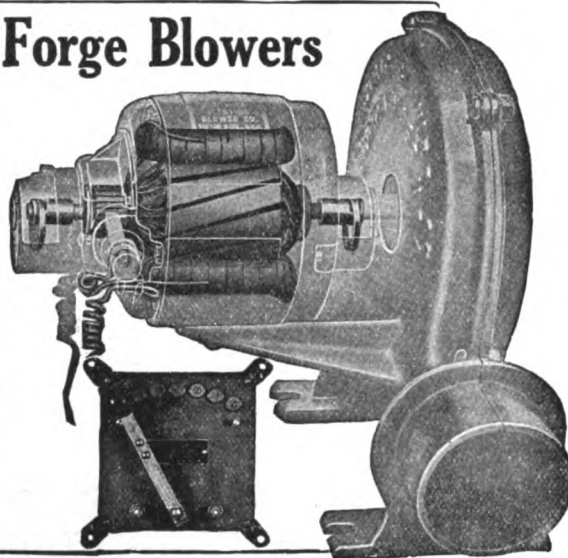

SELDOM SEE

a big knee like this, but your horse may have a bunch or bruise on his ankle, hock, stifle, knee or throat.

ABSORBINE

TRADE MARK REG. U.S. PAT. OFF.

will clean it off without laying up the horse. No blister, no hair gone. Concentrated—only a few drops required at an application. \$2.50 per bottle delivered. Describe your case for special instructions, and Book 8 R free. ABSORBINE, JR., the antiseptic liniment for mankind, reduces Painful Swellings, Enlarged Glands, Wens, Bruises, Varicose Veins; allays Pain and Inflammation. Price \$1.25 a bottle at druggists or delivered. Liberal trial bottle postpaid for 10c. W. F. YOUNG, INC., 230 Temple St., Springfield, Mass.

EMPIRE STEEL WHEELS

Plain or grooved
Tire
To Fit Any Wagon



Farm Trucks
All Standard Types

Write today for
Proposition to Blacksmiths.

Empire Mfg. Co.
P. O. Box 309
QUINCY, ILLINOIS

Get a WITTE

BIG CUT IN ENGINE PRICES

No Cut In Quality

I have made a big smashing reduction in engine prices—for quick shipment—all styles—all sizes—2 to 30 H. P.—Kerosene or Gasoline—Stationary, Portable or Saw-rig—Buy on your own terms. I guarantee safe delivery, make immediate shipment—guarantee every part of your engine against defects as long as you use it—no "strings"—no time limit. Write me at once for prices on this special factory direct offer. Book Free.—Ed. H. Witte, Pres.

WITTE ENGINE WORKS

1762 Oakland Ave. - Kansas City, Mo.
1762 Empire Bldg. Pittsburgh, Pa.

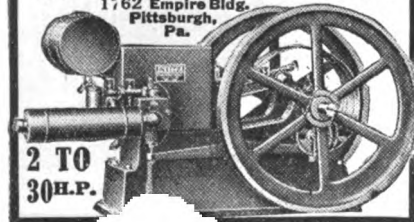

ACCESSORIES AND SUPPLIES OF INTEREST TO THE TRADE.

Continued from page 38

slides, end gate chains, trailer connections, coach hinges, lamp irons, foot board plates, hood fasteners and any other kind of iron fittings required for the construction of vehicle bodies of all kinds.

BALL AND ROLLER BEARINGS OF ALL TYPES AND SIZES

Every automobile, whether passenger car or five ton truck is equipped with a number of ball and roller bearings of various kinds and sizes and the number of such bearings that cars are equipped with forms one of the standard selling points of the salesman.

There is no denying the fact that without bearings of this sort the advances made in automobile construction and service satisfaction would be impossible and hence they are used wherever it is possible to do so.

Every bearing, no matter what type it is or who the maker of it may be is bound to become unserviceable sooner or later, either through wear or breakage and then the problem of obtaining a new bearing arises.

There are very few dealers or service stations that can afford to carry on stock a complete line of roller and ball bearing for all makes and models of cars. And therefore it quite commonly happens that considerable trouble is en-

countered in obtaining a new bearing before the car can be put into commission again.

The Gwilliam Co., Engineers, of 253 W. 58th street, New York and a branch in Philadelphia at 1314 Arch St., is one of the very few firms in the country that is equipped to furnish any type or size of ball or roller bearing at immediate notice. They carry in stock all sizes of single and double row annular ball bearings, ball bearing sheaves, ball thrust bearings of both collar, threaded and groove type, with band; ball thrust step bearings; bronze balls; journal roller bearings; journal roller bearings with casing and sleeve; pressed steel annular bearings; pressed steel combination bearings; Radax bearings; roller thrust bearings; steel balls; taper roller bearings; Taper roller bearings cage type; thrust bearing retainers both open and closed types.

A copy of the Gwilliam Company's catalogue will be mailed to you on request and from it the ordering of any kind or type of ball bearing or part is made a simple matter and as your order is filled immediately on receipt from stock the delay is reduced to a minimum.

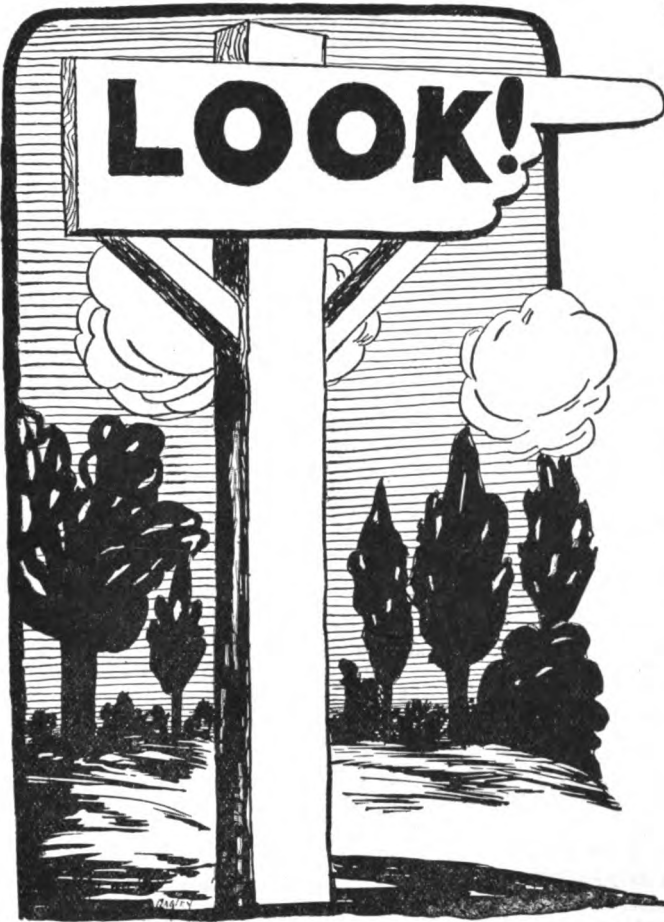

At The Rose Tire Pump

and you will see why it is superior to other pumps. Barrel seamless steel; top and base machined from solid screw stock; patent valve; special tanned cupped leather holding its shape indefinitely.

Brass barrels are easily crushed; top and base of cast iron are unsatisfactory and easily broken; common type of valve construction makes any pump pump hard. Why then buy any but the Rose Tire Pump with the Patent Valve.

| | | |
|-------------------|---------|--------|
| 1½ Rose Tire Pump | - - - - | \$3.50 |
| 1¼ Rose Tire Pump | - - - - | \$3.00 |

Handled by most Jobbers and Dealers

Manufactured and Guaranteed by

J. H. HANEY & CO.

Hastings,

Nebraska

YOU CAN WELD STEEL AS EASILY AS IRON



Especially adapted for welding tires, axles, springs and all lap welding.

Either of these compounds will weld steel at the lowest possible heat that steel can be welded. Also protects steel at high heat.

Owing to our improved process of manufacturing, these compounds do not boil off and waste in the fire, but adhere to the metal when applied.

FOR SALE BY ALL LEADING DEALERS IN BLACKSMITH SUPPLIES IN UNITED STATES AND CANADA

Large Free Sample Sent on Request

CORTLAND WELDING COMPOUND CO., Cortland, N. Y.



PREPARED ESPECIALLY FOR WELDING FAR SUPERIOR TO COMMON BORAX

A flux which causes the steel to weld like iron. Not necessary to apply between the lap, but may be applied to the outer surface of the work, the same as borax. Has no equal for plow work. Just the thing for welding too-calks so they can't knock off.

LOWER PRICES ON WHEELS

Get our new Catalogue No. 61

Wheel Top & Hdw. Co.

Dept. W1,

Cincinnati, Ohio

Buy Now But Buy

Wisely

PATENTS HERBERT JENNER, Patent Attorney and Mechanical Expert, 622 F St., Washington, D. C. Established 1883. I make a free examination and report if a patent can be had and exactly what it will cost. Send for circular.

PATENTS

C. L. PARKER, Ex-Member Examining Corps, U. S. Patent Office Attorney-at-Law and Solicitor of Patents American and foreign Patents secured, Trade marks registered. Searches made to determine patentability, validity and infringement. Patent Suits conducted. Pamphlet of instructions sent upon request. McGill Building WASHINGTON, D. C.

PATENTS

Inventors Invited to Write for Information and Particulars. Highest References. Best Results. Promptness Assured. WATSON E. COLEMAN Patent Lawyer 624 F Street N. W., Washington, D. C.

Your Prospective Customers are listed in our Catalog of 99% guaranteed Mailing Lists. It also contains vital suggestions how to advertise and sell profitably by mail. Counts and prices given on 9000 different national Lists, covering all classes; for instance, Farmers, Noodle Mfrs., Hardware Dirs., Zinc Mines, etc. This valuable reference book free. Write for it. Send Them Sales Letters You can produce sales or inquiries with personal letters. Many concerns all over U. S. are profitably using Sales Letters we write. Send for free instructive booklet, "Value of Sales Letters."

Ross-Gould Mailing Lists St. Louis

WANTED AND FOR SALE

Want and For Sale advertisements, situations and help wanted, five cents a word. Send cash with order. No charge less than fifty cents. The small cost of these advertisements prevents our investigating and guaranteeing them. WE WILL NOT knowingly accept any but reliable ones.

WANTED—To hear from owner of good Blacksmith Shop for sale. State cash price, description. D. F. BUSH, Minneapolis, Minn.

FOR SALE—Automobile, Marine and stationary engines 1 to 100 H. P. Best makes, good condition, very low prices. State your power needs. We take engines in trade. What have you? Magnetos, coils, carburetors, mechanical oilers, water pumps, etc. Also car parts of every nature—sacrifice prices. Write about your requirements. BADGER MOTOR COMPANY, Milwaukee, Wis.

BLACKSMITHS LISTEN: Save time and money by doing your own auto and tractor blacksmithing with Toy's modern methods doing hard jobs easy. Forging and making solid welds, hardening and tempering to a standard, with colored tempering charts. All for one dollar. Samples free. W. M. TOY, Sidney, Ohio.

FOR SALE—1 3/4 inch, 1 1/2 inch, 1 1/4 inch Goodyear Wing internal rubber tire, also one Kelly applying machine Cheap. Born Vulcanizing & Tire Agency, Belleville, Ill.

WANTED—Good allround blacksmith at once. Young married man preferred. M. W. ABTS, Morrill, Nebr.

CUMMINGS & EMERSON BLACKSMITH SUPPLIES Send for Catalogue of Automobile Supplies. PEORIA, ILLINOIS

ACCESSORIES AND SUPPLIES OF INTEREST TO THE TRADE. NEW GREASE FOUND FOR ALL-ROUND USE—DISCOVERY ANNOUNCED BY CHEMISTS EXPECTED TO PROVE EPOCH-MAKING

The discovery of a practical all-round motor grease is announced by Cleveland chemists of the National Refining Company, who make the confident claim that their discovery will fill a long-felt want in efficiency as well as in comprehensive usefulness.

Undoubtedly the new grease will be welcome to all motorists, whether they drive automobiles, tractor or truck, because of its convenience. Its discovery means that instead of a variety of greases—one for compression cups, another for differentials, a third for transmissions, etc.—the one will provide perfect lubrication on any grease point. Chemists say it will not deteriorate.

In the oil world the discovery is heralded as epoch-making and especially timely.

The new grease is already on the market, being manufactured and sold by the National Refining Company, and has been christened "En-ar-co Motor Grease."

FRANK S. CORLEW MANAGES NEW ENGLAND VULCAN BRANCH

Frank S. Corlew, one of the most prominent and aggressive men in the Automobile Industry, is now manager of the New England Branch of the Jenkins VULCAN Spring Company. Mr. Corlew was quick to realize the commercial possibilities of the product of the Jenkins VULCAN Spring Company of Richmond, Indiana, with relation to the New England



FRANK S. CORLEW

territory. An appreciation of the established reputation of this Company, combined with resources of a most staple character, was responsible in a great measure to his decision to direct the activities of the Jenkins Company in New England. The New England Branch is located at 819 Boylston Street, Boston, Mass., where ample facilities to handle the constantly increasing volume of business will be maintained.

Mr. Corlew's experience dates back from the time that the bicycle business was in the "hey day" of success. His mercantile career began about 15 years ago when he became Sales Manager of the New England Branch of the Fowler

(Continued on page 42)

1918 Model The L. S. P. Calking Machine

The Greatest Time and Labor Saving Machine on Earth

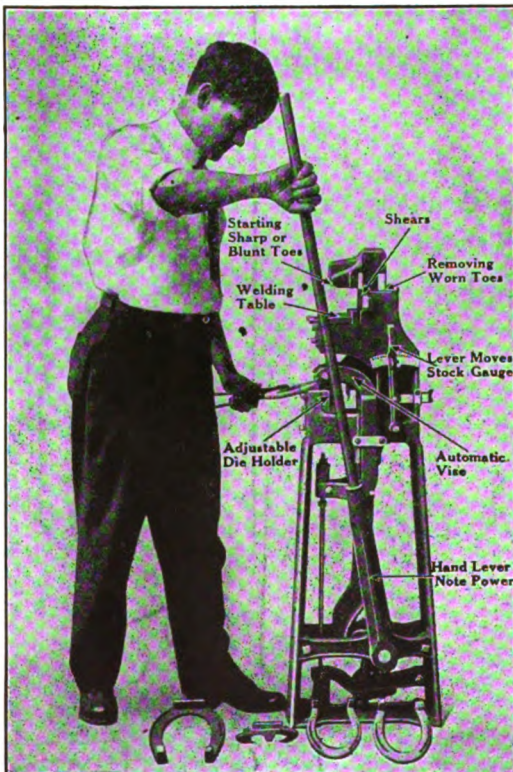

OUR 1918 Model is the same as our 1917 Model with the exception that we have eliminated the steel plunger attachment and strengthened some of the parts.

Do not mistake this for a machine which makes toe calks or a foot vice. This machine is for turning heel calks, both Blunt and Sharp, sticking and welding toe calks, clipping and trimming ends of shoes. IT CALKS SHOES, doing the work just the same as you do by hand with the hammer, only it is done much better and easier, and in a fraction of the time.

In turning heels, you can turn up just as much stock as you wish, upset or stoveup to make as heavy as you like and square up the calks without use of hammer. There is no losing of toes when you weld on the L. S. P.

It is a strong, handsome, well-made machine, and will last, as you might say, a life time, fully warranted for one year. It is in use in the best shops in the United States, users claiming more for it than we do. Write at once for full information and prices.

L. S. P. CALKING MACHINE COMPANY

Peoples' State Bank Building Wyalusing, Pa., U. S. A.

National Machine Co., Brighton, Ont., Canada

1918 MODEL Fully covered with Patents

SEE THAT SPRING

THIS spring is entirely different from other springs. The **Alford Auxiliary Springs** furnish additional spring tension. They will permit you to carry a $\frac{3}{4}$ ton load and they will **absorb** the road shocks that the tires and rear axles ordinarily have to stand. It takes from 30 minutes to an hour to install this attachment. These springs are mechanically perfect and are fully guaranteed.

Attachment for
Model T Fords,
\$16.00

PATENTED

This shows the Alford Auxiliary Spring properly attached to car.

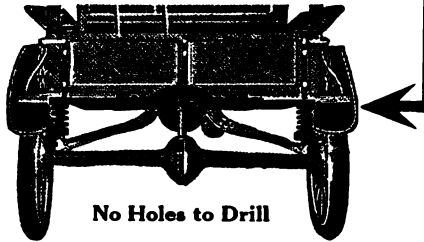

No Holes to Drill

Your locality is full of prospective customers. Every Ford owner is a prospect. It will pay you to investigate this opportunity.

Agents wanted everywhere—Write today for particulars and literature.

ANDREW HOFFMAN MFG. CO.

5036 So. State Street,

CHICAGO, ILLINOIS

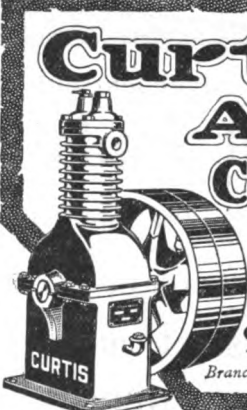

Curtis Air Compressors

FREE
CURTIS-AIR
FREE FROM OIL

Install a Curtis and furnish your patrons with CURTIS AIR—FREE FROM OIL. The Curtis sign (free with each Curtis Compressor) inspires confidence and helps build your business. Ask your jobber or write us for full information.

Curtis Pneumatic Machinery Co.
1514 Kienlen Ave., St. Louis, Mo.
Branch Office—530-M Hudson Terminal, New York City

With This Machine

Your shop is capable of repairing wheels quickly at reasonable cost and you can depend on obtaining plenty of other automobile work. The **Universal Wheel Compressor** is so constructed that repair work may be done speedily on all types of auto and truck wheels. Wire spoke wheels as easily repaired as wooden ones.

The **compressor** is strong enough to compress the heavy truck wheels.

Write for Information.

Universal Wheel Compressor Co.
Lake St., Cedar Rapids, Iowa.



Adjust to give any dish desired

THE VETERAN HORSESHOER LOOKS BACK UPON **35 YEARS** OF COMPLETE SATISFACTION WITH THE **BOSS IRON & BANNER STEEL** HORSE AND MULE SHOES

and we strive NOW to maintain that standard of quality which marked so plainly the "BOSS" shoe in 1882.

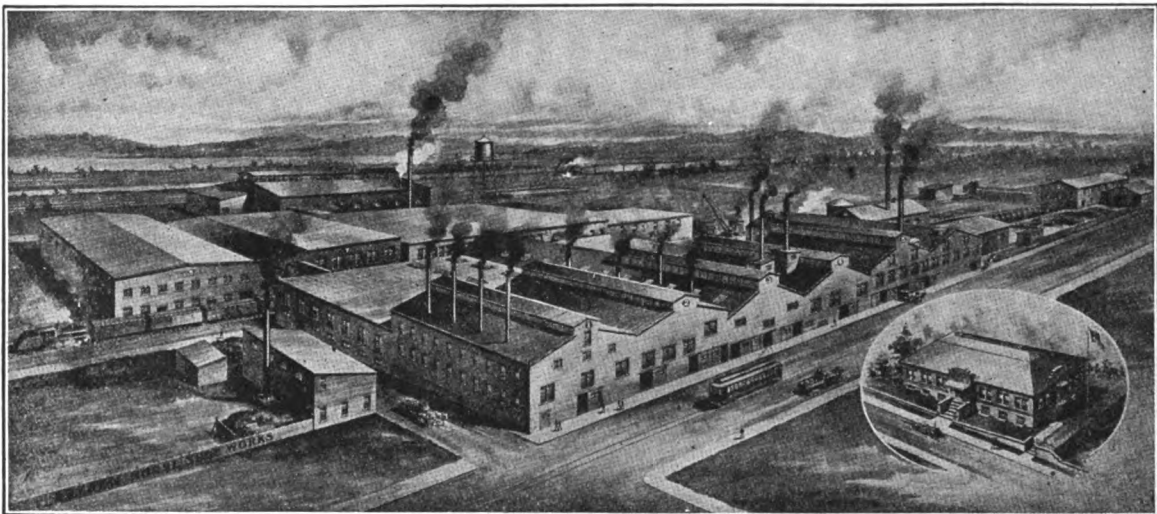

Bryden Horse Shoe Works
Catasauqua, Penna.

SEND FOR DESCRIPTIVE CATALOG.



If you have never learned by actual experience just how good

Pioneer Shaft Ends

are, do it now by ordering a few of your jobber, and don't let him pawn off on you the "just-as-good," "may suit" brand. Look for the Pioneer

trade-mark on the wrappers. Possibly you order a certain kind of horse nails and shoes because they are better and please. So why not specify **Pioneer Shaft Ends** for the same reason? Once you get acquainted, they will be your affinity ever afterwards.

Pioneer Shaft Ends are the kind that are easy to fit, and make the strongest joint.

THREE SIZES:—BUGGY, SURREY AND LIGHT BUGGY.

Made by **The Brewer-Titchener Corporation,**

Cortland N. Y.

"MARVEL" Forge Blowers

This cut shows you the **RING OIL BEARING** design and construction of the motors used in our "ONE FIRE" \$28.00 **MARVEL** and and on our No. 23 **MARVEL** \$25.00 Blowers, the windings being different.

Note the large oil rings which revolve with the **CASE HARDENED**, shaft keeping it running in a perfect bath of oil on the bearings. Perfect lubrication means long life.

Shipped on 30 days' trial through your dealer.

Electric Blower Co.
Boston, Mass.

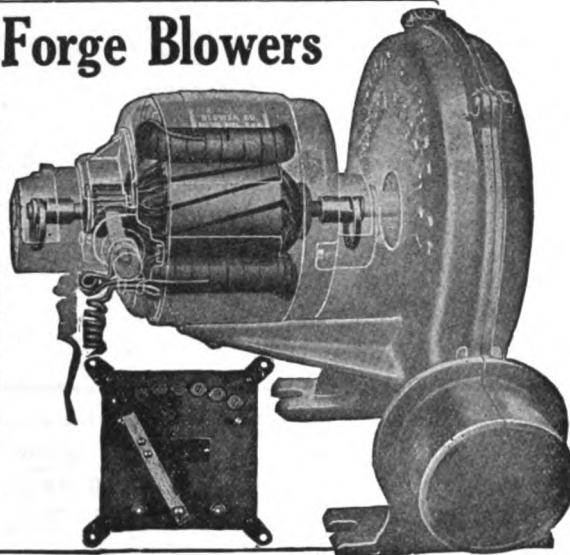

ACCESSORIES AND SUPPLIES OF INTEREST TO THE TRADE.

Continued from page 40

Bicycle Company, whose headquarters were in Chicago. When the Motor Car became a commercial success Mr. Corlew became Sales Manager of the Adams Sutton Company, who were the pioneer distributors for the Oldsmobile in New England. In 1909 he was prominently identified with the introduction of the Velie in New England territory, as well as, the distribution of several other prominent makes of automobiles.

Eight years later Mr. Corlew accepted the position of Manager of the Washington Office of the Motor Products Corporation of Detroit. While in this capacity he was in full charge of this concern's operations during their cooperation with the United States Government during the World War. The same aggressive, as well as progressive methods, for which Mr. Corlew is well known, will be the policy upon which a greater distribution and more thorough appreciation of the Jenkins VULCAN Spring Company will be founded. Mr. Corlew is a prominent member of the Bay State Automobile Association and other Motor organizations, as well as an enthusiastic Yachtsman, and one of the best known Automobile men in Boston and the New England territory.

Steam Engine Troubles.—By H. Hamkens, 350 pages, 276 illustrations. Price \$2.50 postpaid to any address.

It is safe to say that no book has ever been published which gives the practical engineer such valuable and comprehensive information on steam engine design and troubles. There are descriptions of cylinders, valves, pistons, frames, pillow blocks and other bearings, connecting rods, wristplates, dashpots, reach rods, valve gears, governors, piping, throttle and emergency valves, safety stops, flywheels, oilers, etc. If there is any trouble with these parts, this book will give you the reasons and tell how to remedy them.

Big Reduction

In Engine Prices No Cut In Quality Immediate Shipment

They all said "it couldn't be did". Materials are **not** lower, construction cost is **not** lower, prices of food products are still high—but I have made a **big smashing reduction** in engine prices for quick shipment—all styles, all sizes, 2 to 30 H-P.—Kerosene or Gasoline. My prices are direct from factory and so low that you cannot afford to wait a day longer.

BUY ON YOUR OWN TERMS

I don't expect to make a dollar on this wide-open offer, but I am going to keep my big factory running at full blast regardless of profit. You get the benefit—buy on your own terms, as arranged for, take any style engine you want.

I guarantee safe delivery to all parts of the U.S., and further guarantee every part of your engine against defect as long as you own it—no "strings"—no time limit. Write me at once for 1919 catalog and get your engine at a big saving—Ed. H. Witte.

WITTE ENGINE WORKS
1763 Oakland Ave., - Kansas City, Mo.
1763 Empire Bldg., - Pittsburg, Pa.

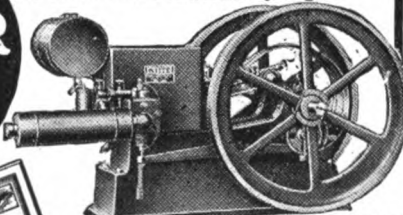

Mail This Coupon 1763 For Lowest WITTE Prices

Name _____
Town _____
State _____ R.F.D. _____

FODEN'S MECHANICAL TABLES

SAVE ALL FIGURING!

Tell at a glance how much stock to use for oval or elliptical hoops of any size, the circumferences of circles, weight of flat, square and round stock, and the weight and strength of ropes and chains.

Should be in every progressive Smith's hands. Bound very neatly in green cloth. Price, 85c. **AMERICAN BLACKSMITH, AUTO & TRACTOR SHOP** Buffalo, New York

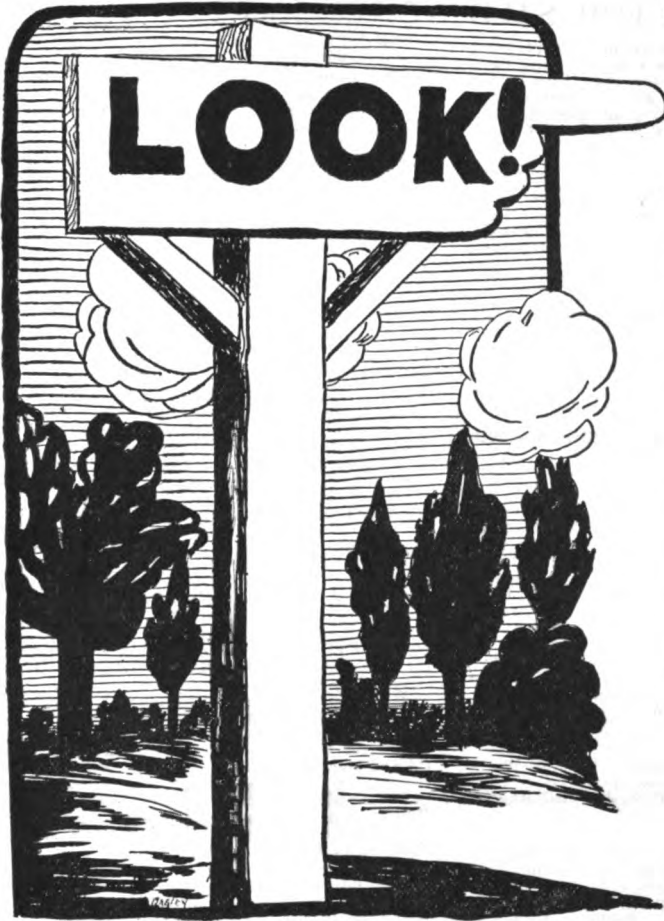

At The Rose Tire Pump

and you will see why it is superior to other pumps. Barrel seamless steel; top and base machined from solid screw stock; patent valve; special tanned cupped leather holding its shape indefinitely.

Brass barrels are easily crushed; top and base of cast iron are unsatisfactory and easily broken; common type of valve construction makes any pump pump hard. Why then buy any but the Rose Tire Pump with the Patent Valve.

- 1½ Rose Tire Pump - - - - \$3.50
- 1¼ Rose Tire Pump - - - - \$3.00

Handled by most Jobbers and Dealers

Manufactured and Guaranteed by

J. H. HANEY & CO.

Hastings,

Nebraska

YOU CAN WELD STEEL AS EASILY AS IRON



Especially adapted for welding tires, axles, springs and all lap welding.

Either of these compounds will weld steel at the lowest possible heat that steel can be welded. Also protects steel at high heat.

Owing to our improved process of manufacturing, these compounds do not boil off and waste in the fire, but adhere to the metal when applied.

FOR SALE BY ALL LEADING DEALERS IN BLACKSMITH SUPPLIES IN UNITED STATES AND CANADA

Large Free Sample Sent on Request



PREPARED ESPECIALLY FOR WELDING FAR SUPERIOR TO COMMON BORAX

A flux which causes the steel to weld like iron. Not necessary to apply between the lap, but may be applied to the outer surface of the work, the same as borax. Has no equal for plow work. Just the thing for welding toe-calks so they can't knock off.

CORTLAND WELDING COMPOUND CO., Cortland, N. Y.

Our Victor Brand RUBBER TIRE

In full reel lots 3c lb.



less than reel lots 40c lb.

Get our prices on wheels, rims, spokes, tires, shafts, bolts, etc.

Ask for catalog No. 61

Wheel Top & Hardware Co.

Dept. W 1

CINCINNATI, O.

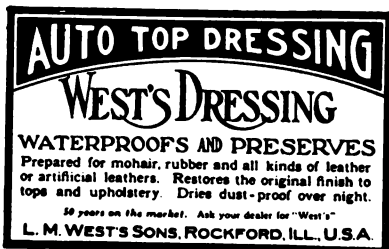

PATENTS **HERBERT JENNER.**
Patent Attorney and Mechanical Expert, 622 F St., Washington, D. C. Established 1883. I make a free examination and report if a patent can be had and exactly what it will cost. Send for circular.

PATENTS

C. L. PARKER
Ex-Member Examining Corps, U. S. Patent Office
Attorney-at-Law and Solicitor of Patents
American and foreign Patents secured. Trade marks registered. Searches made to determine patentability, validity and infringement. Patent Suits conducted. Pamphlet of instructions sent upon request.
McGill Building WASHINGTON, D. C.

PATENTS

Inventors invited to Write for Information and Particulars.
Highest References, Best Results, Promptness Assured.
WATSON E. COLEMAN
Patent Lawyer
624 F Street N. W., Washington, D. C.

Your Prospective Customers
are listed in our Catalog of 99% guaranteed Mailing Lists. It also contains vital suggestions how to advertise and sell profitably by mail. Counts and prices given on 9000 different national Lists, covering all classes; for instance, Farmers, Noodle Mfrs., Hardware Dirs., Zinc Mines, etc. *This valuable reference book free.* Write for it.
Send Them Sales Letters
You can produce sales or inquiries with personal letters. Many concerns all over U. S. are profitably using Sales Letters we write. Send for free 1 structure booklet, "Value of Sales Letters."
Ross-Gould
Mailing Lists St. Louis

WANTED AND FOR SALE

Want and For Sale advertisements, situations and help wanted, five cents a word. Send cash with order. No charge less than fifty cents. The small cost of these advertisements prevents our investigating and guaranteeing them. **WE WILL NOT knowingly accept any but reliable ones.**

FARM with your Ford and do 2 days work in 1. Agents make \$100 weekly. Money back guarantee. Write today for free circular.
GENEVA TRACTOR CO., Dept. 8 Geneva, Ohio.

FOR SALE:—Automobile, Marine and stationary engines 1 to 100 H. P. Best makes, good condition, very low prices. State your power needs. We take engines in trade. What have you? Magnets, coils, carburetors, mechanical oilers, water pumps, etc. Also car parts of every nature—sacrifice prices. Write about your requirements.
BADGER MOTOR COMPANY, Milwaukee, Wis.

BLACKSMITHS LISTEN: Save time and money by doing your own auto and tractor blacksmithing with Toy's modern methods doing hard jobs easy. Forging and making solid welds, hardening and tempering to a standard, with colored tempering charts. All for one dollar. Samples free. **W. M. TOY, Sidney, Ohio.**

FOR SALE.—1 1/2 inch, 1 1/4 inch, 1 1/8 inch Goodyear Wing internal rubber tire, also one Kelly applying machine. Cheap.
Born Vulcanizing & Tire Agency, Belleville, Ill.

WANTED—Good allround blacksmith at once. Young married man preferred.
M. W. ABTS, Morrill, Nebr.

WANTED AT ONCE—A-1 Horseshoer in well-equipped shop. Steady year-round work to right man at good wages. Apply
GEO. E. STOOKING CANNING FACTORY, Rochelle, Illinois.

WANTED—First-class Active Working Foreman. Blacksmith with experience in oil and gas well drilling equipment preferred, but main consideration in selecting a man for this place will be thorough knowledge of his business, ability to handle men and a record for rapid and accurate production. In making application give age, experience in detail, wages wanted, and references. This is a permanent position with lots of work and good living and working conditions. Apply
BOX 183, Parkersburg, W. Va.

FOR SALE—Good horse-shoeing, wagon repair and blacksmith shop fully equipped and well stocked. Located at Valier, Montana, the center of the famous Valier Irrigation System. The shop 26x50 feet and a seven room modern residence are located on a lot 50x140 feet in the heart of the town. Owner must sell on account of ill health. Full description and list of stock, machinery and equipment will be furnished to anyone interested. Write
R. M. SAUER, Valier, Montana.

FOR SALE—Blacksmith business complete. Highest prices; good location; sell cheap. For particulars address **BOX 106, Covert, Michigan.**

FOR SALE—Blacksmith shop, tools, plenty of material to work with. Wood working machinery driven by 5 H. P. electric motor. New building located on state road. The only shop in town. (Population 4,000.) Must be sold on account of death of owner. Price \$2200.
MRS. A. S. TUCKER, Administratrix, BOX 193, Seaford, Del.

WANTED—Information of blacksmith shop for sale. **C. C. SHEPARD, Minneapolis, Minn.**

WANTED—First-class blacksmith, one capable of taking charge of Smith Department of carriage shop and general repair shop. Good wages for the right man. **THE ENTERPRISE CARRIAGE COMPANY, Tarboro, N. C.**

FOR SALE—A few rebuilt ROTO Electric Blowers, good as new. One year guarantee. Until sold \$25.00. **THE ROSEWATER ELECTRIC CO., Cleveland, Ohio.**

For Sale—A good Blacksmith Shop. Will sell cheap on account of health. In a good town seven miles from county seat.
H. P. VEDRICKSON, New Cambria, Kansas.

FOR SALE—My blacksmith shop, tools and stock, also house and 1 1/2 acres land, with stable and crib. Will sell a part or all, on account of other business. One of the best locations in Kentucky, and a good farming country. WM SPIOFR, RR. No. 1, Williams-town, Cherry Grove, Ky.

CUMMINGS & EMERSON
BLACKSMITH SUPPLIES
Send for Catalogue of Automobile Supplies.
PEORIA, ILLINOIS

ACCESSORIES AND SUPPLIES OF INTEREST TO THE TRADE.
SHAFFER ROLLER BEARINGS NOT MADE FOR MAXWELLS

A steady demand from Maxwell car owners for a front wheel bearing that will take 100 per cent end thrust without damage to the bearing has forced the George D. Shafer Company of Chicago to include the Maxwell among the cars for which the Shafer is especially fitted. This enlarges the field considerably in which Shafers can be used and enables the blacksmith who repairs cars to widen his scope of operation.

The Shafer roller bearing is self-aligning and is now being widely used for Ford and Chevrolet 490 front wheels.

JEFFERSON COILS

The Automobile Ignition Coil situation has, in the past, been a serious problem for jobbers, dealers and service stations, owing to the multiplicity of types on the market. Many jobbers and dealers have had to pass up the Coil Field almost entirely, because of the large and varied stock of Coils that would be necessary to take care of all requirements.

(Continued on page 42)

1918 Model The L. S. P. Calking Machine

The Greatest Time and Labor Saving Machine on Earth

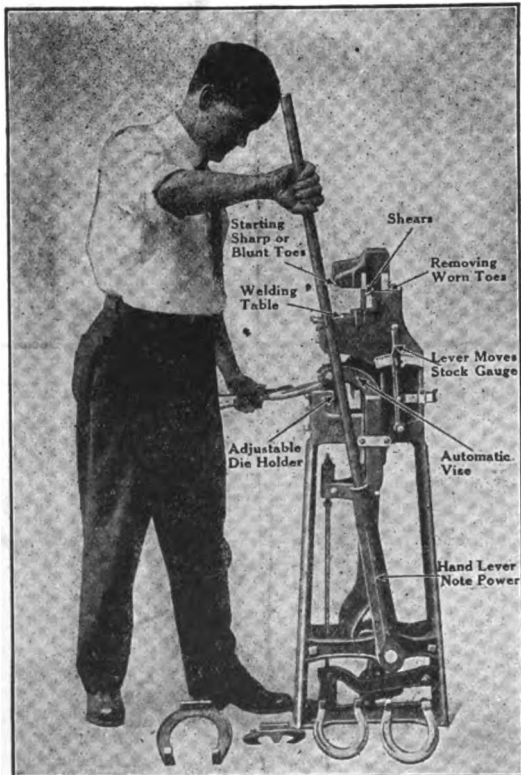

OUR 1918 Model is the same as our 1917 Model with the exception that we have eliminated the steel pluggers attachment and strengthened some of the parts.

Do not mistake this for a machine which makes toe calks or a foot vice. This machine is for turning heel calks, both Blunt and Sharp, sticking and welding toe calks, clipping and trimming ends of shoes. **IT CALKS SHOES, doing the work just the same as you do by hand with the hammer, only it is done much better and easier, and in a fraction of the time.**

In turning heels, you can turn up just as much stock as you wish, upset or stove up to make as heavy as you like and square up the calks without use of hammer. There is no losing of toes when you weld on the L. S. P.

It is a strong, handsome, well-made machine, and will last, as you might say, a life time, fully warranted for one year. It is in use in the best shops in the United States, users claiming more for it than we do. Write at once for full information and prices.

L. S. P. CALKING MACHINE COMPANY

Peoples' State Bank Building
Wyalusing, Pa., U. S. A.
National Machine Co.,
Brighton, Ont., Canada

1918 MODEL
Fully covered with Patents

DEALERS

Alford Auxiliary Spring Attachments will net you a good profit

This SPRING attachment is entirely different from others. While it adds spring tension to permit you to carry a 3/4 ton load it also absorbs the road shocks that the tires and rear axle ordinarily have to stand, and prevents the swinging and tipping of the body, as well as cutting the center bolt of rear spring; which would cause the body to lean to one side.



No Holes to Drill

Attachment for Model T Fords, \$16.00

A Quick Seller to all who use Fords for Commercial Purposes

Your locality is full of prospective customers. Every Ford owner is a prospect. It will pay you to investigate this opportunity.

These springs are mechanically perfect and are fully guaranteed.

Agents wanted everywhere—Write today for particulars and literature.

ANDREW HOFFMAN MFG. CO.

5036 So. State Street,

CHICAGO, ILLINOIS

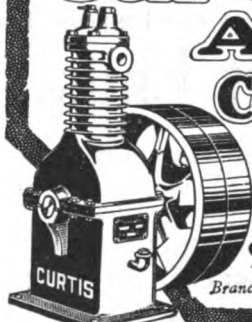

Curtis Air Compressors

**FREE
CURTIS-AIR
FREE FROM OIL**

Install a Curtis and furnish your patrons with CURTIS AIR—FREE FROM OIL. The Curtis sign (free with each Curtis Compressor) inspires confidence and helps build your business. Ask your jobber or write us for full information.

Curtis Pneumatic Machinery Co.
1514 Kienlen Ave., St. Louis, Mo.
Branch Office—530-M Hudson Terminal, New York City



Adjust to give any dish desired

With This Machine

Your shop is capable of repairing wheels quickly at reasonable cost and you can depend on obtaining plenty of other automobile work. The **Universal Wheel Compressor** is so constructed that repair work may be done speedily on all types of auto and truck wheels. Wire spoke wheels as easily repaired as wooden ones. The **compressor** is strong enough to compress the heavy truck wheels.

Write for Information.

Universal Wheel Compressor Co.
Lake St., Cedar Rapids, Iowa.

THE VETERAN HORSESHOER LOOKS BACK UPON **35 YEARS** OF COMPLETE SATISFACTION WITH THE **BOSS IRON & BANNER STEEL** **HORSE AND MULE SHOES**

and we strive NOW to maintain that standard of quality which marked so plainly the "BOSS" shoe in 1882.

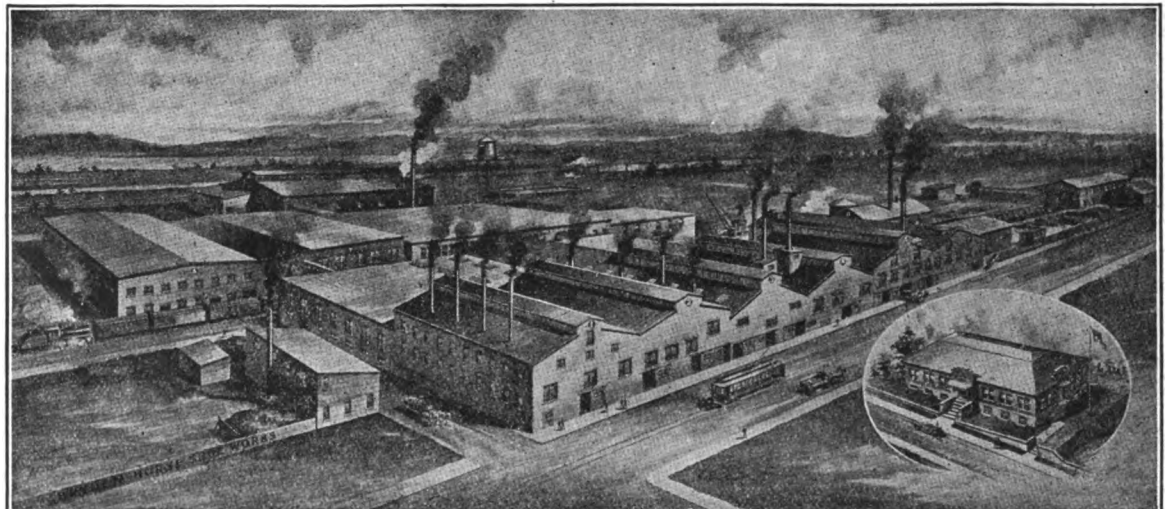

Bryden Horse Shoe Works
Catasauqua, Penna.

SEND FOR DESCRIPTIVE CATALOG.

SHAFT

Pioneer Shaft Ends are, do it now by ordering a few of your jobber, and don't let him pawn off on you the "just-as-good," "may suit" brand. Look for the Pioneer trade-mark on the wrappers. Possibly you order a certain kind of horse nails and shoes because they are better and please. So why not specify **Pioneer Shaft Ends** for the same reason? Once you get acquainted, they will be your affinity ever afterwards.

Pioneer Shaft Ends are the kind that are easy to fit, and make the strongest joint.
THREE SIZES:—BUGGY, SURREY AND LIGHT BUGGY.

Made by **The Brewer-Titchener Corporation,** **Cortland N. Y.**

"MARVEL" Forge Blowers

This cut shows you the RING OIL BEARING design and construction of the motors used in our "ONE FIRE" \$38.00 MARVEL Blowers.

Note the large oil rings which revolve with the CASE HARDENED shaft, keeping it running in a perfect bath of oil on the bearings. Perfect Lubrication means long life.

Shipped on 30 days trial through your dealer.

Electric Blower Co.
 Boston, Mass.

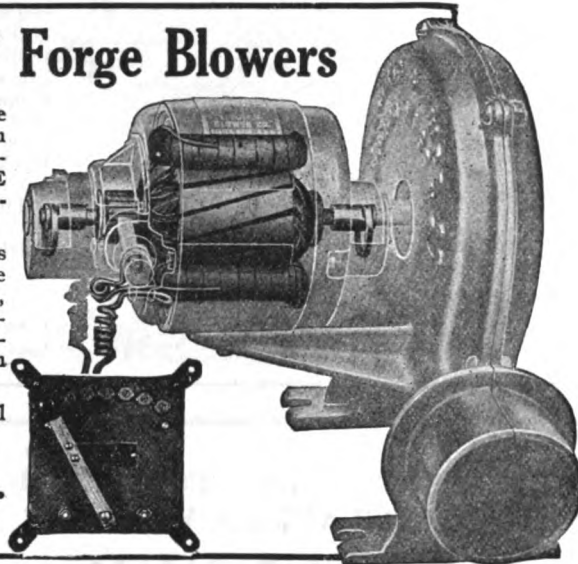

ACCESSORIES AND SUPPLIES OF INTEREST TO THE TRADE.

(Continued from page 40)

The Jefferson Electric Manufacturing Company of Chicago have recently placed on the market a line of Battery Replacement Coils and Fittings which are sufficiently flexible to displace any Type of Coil on Battery-Equipped cars. The extreme flexibility of Jefferson Coils is obtained from several features, which include the Fittings, Adjustable Caps, Terminals and Mounting Arrangements.

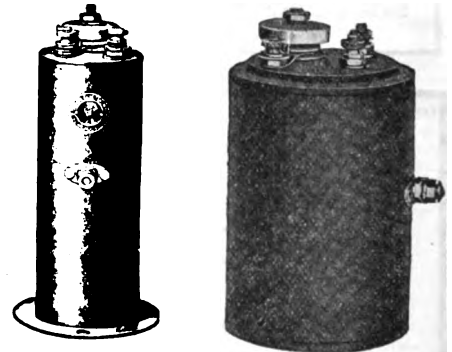

With a small stock of Jefferson Coils, any service station, garage or repair shop will be prepared for any emergency. Heretofore, it has been necessary to lay up a car for perhaps several days while a new Coil was being obtained. Now, however, any car can be placed in service within a few minutes. It is only necessary to remove the old Coil and connect the Jefferson.

Starting conditions require a Coil that will produce a hot, intense spark when the battery is at the lowest ebb. Jefferson Coils are guaranteed to take care of this extreme condition.

To aid jobbers, dealers, service stations and garage men, the Jefferson Electric Manufacturing Company have compiled a folder containing complete and authentic data covering all standard Battery Ignition Systems. This folder lists all makes of cars from 1912 to the present date, and give the year, model, type of ignition and style of Jefferson Coil to be used for replacement. This folder will be sent free of charge to any dealer, garage, service station or jobber. Request should be addressed to the Jefferson Electric Manufacturing Company, 437 S. Green Street, Chicago.

Big Reduction In Engine Prices

No Cut In Quality Immediate Shipment

They all said "it couldn't be did". Materials are **not** lower, construction cost is **not** lower, prices of food products are still high—but I have made a **big smashing reduction** in engine prices for quick shipment—all styles, all sizes, 2 to 30 H.P.—Kerosene or Gasoline. My prices are direct from factory and so low that you cannot afford to wait a day longer.

BUY ON YOUR OWN TERMS

I don't expect to make a dollar on this wide-open offer, but I am going to keep my big factory running at full blast regardless of profit. You get the benefit—buy on your own terms, as arranged for, take any style engine you want.

I guarantee safe delivery to all parts of the U.S., and further guarantee every part of your engine against defect as long as you own it—no "strings"—no time limit. Write me at once for 1919 catalog and get your engine at a big saving—Ed. H. Witte.

WITTE ENGINE WORKS
 1763 Oakland Ave., - Kansas City, Mo.
 1763 Empire Bldg., - Pittsburg, Pa.

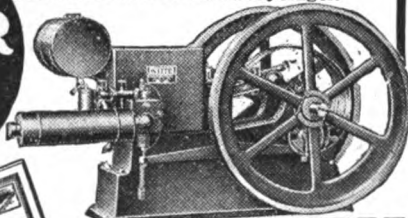

Mail This Coupon 1763 For Lowest WITTE Prices

Name _____
 Town _____
 State _____ R.F.D. _____

DEALERS

Alford Auxiliary Spring Attachments will net you a good profit

This SPRING attachment is entirely different from others. While it adds spring tension to permit you to carry a 3/4 ton load it also absorbs the road shocks that the tires and rear axle ordinarily have to stand, and prevents the swinging and tipping of the body, as well as cutting the center bolt of rear spring; which would cause the body to lean to one side.

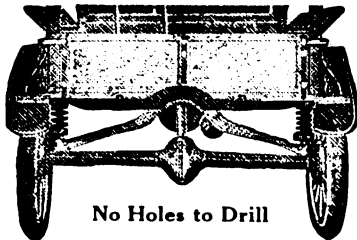

No Holes to Drill

Attachment for Model T Fords, \$16.00

A Quick Seller to all who use Fords for Commercial Purposes

Your locality is full of prospective customers. Every Ford owner is a prospect. It will pay you to investigate this opportunity.

These springs are mechanically perfect and are fully guaranteed.

Agents wanted everywhere—Write today for particulars and literature.

ANDREW HOFFMAN MFG. CO.

5036 So. State Street,

CHICAGO, ILLINOIS



Curtis Air Compressors

Install a Curtis and furnish your patrons with CURTIS AIR—FREE FROM OIL. The Curtis sign (free with each Curtis Compressor) inspires confidence and helps build your business. Ask your jobber or write us for full information.

Curtis Pneumatic Machinery Co.
1514 Kienlen Ave., St. Louis, Mo.
Branch Office—530-M Hudson Terminal, New York City

**FREE
CURTIS-AIR
FREE FROM OIL**

With This Machine



Adjust to give any dish desired

Your shop is capable of repairing wheels quickly at reasonable cost and you can depend on obtaining plenty of other automobile work. The Universal Wheel Compressor is so constructed that repair work may be done speedily on all types of auto and truck wheels. Wire spoke wheels as easily repaired as wooden ones.

The compressor is strong enough to compress the heavy truck wheels.

Write for Information.

Universal Wheel Compressor Co.
Lake St., Cedar Rapids, Iowa.

THE VETERAN HORSESHOER LOOKS BACK UPON 35 YEARS OF COMPLETE SATISFACTION WITH THE BOSS IRON & BANNER STEEL HORSE AND MULE SHOES

and we strive NOW to maintain that standard of quality which marked so plainly the "BOSS" shoe in 1882.

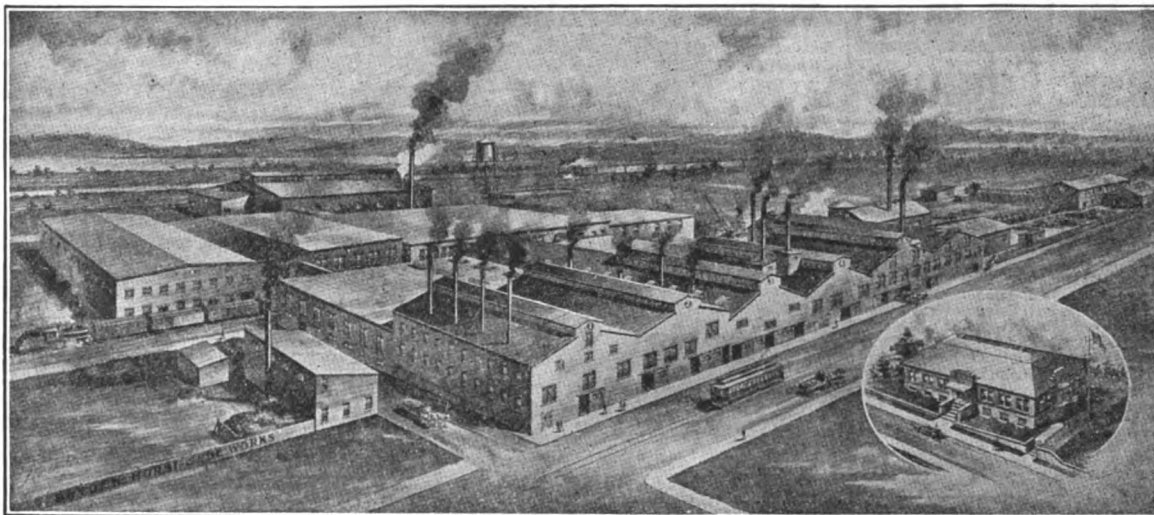

Bryden Horse Shoe Works
Catasauqua, Penna.

SEND FOR DESCRIPTIVE CATALOG.

SHAFT

If you have never learned by actual experience just how good

Pioneer Shaft Ends

are, do it now by ordering a few of your jobber, and don't let him pawn off on you the "just-as-good," "may suit" brand. Look for the Pioneer trade-mark on the wrappers. Possibly you order a certain kind of horse nails and shoes because they are better and please. So why not specify **Pioneer Shaft Ends** for the same reason? Once you get acquainted, they will be your affinity ever afterwards.

Pioneer Shaft Ends are the kind that are easy to fit, and make the strongest joint. **THREE SIZES:—BUGGY, SURREY AND LIGHT BUGGY.**

Made by **The Brewer-Titchener Corporation,** **Cortland N. Y.**

"MARVEL" Forge Blowers

This cut shows you the RING OIL BEARING design and construction of the motors used in our "ONE FIRE" \$38.00 MARVEL Blowers.

Note the large oil rings which revolve with the CASE HARDENED shaft, keeping it running in a perfect bath of oil on the bearings. Perfect Lubrication means long life.

Shipped on 30 days trial through your dealer.

Electric Blower Co.
Boston, Mass.

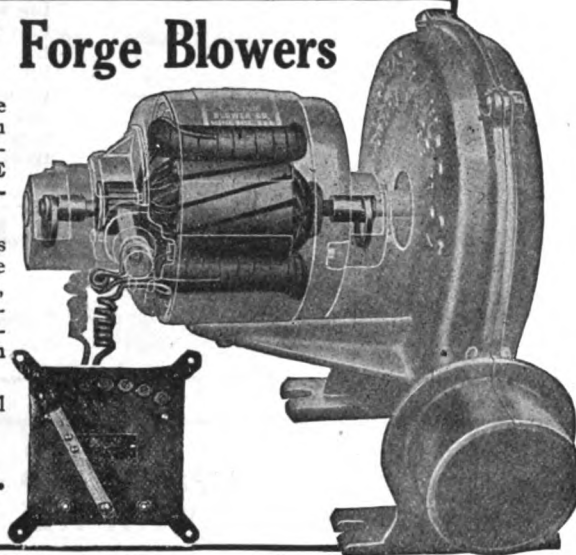

ACCESSORIES AND SUPPLIES OF INTEREST TO THE TRADE.

The Norton Company of Worcester, Massachusetts, manufacturers of Alundum and Crystolon grinding wheels and other abrasive products have announced the opening of a store in Detroit, Michigan, at 73-75 West Congress Street.

With the growth of the automobile and other great industries in the Detroit vicinity there has been a corresponding increase in the demand for grinding wheels and other abrasives. It has been said that there are more grinding wheels used in Detroit than in any city in the world.

In addition to carrying in the Detroit store an ample stock of grinding wheels such as used in Detroit and vicinity, the Norton Company, will expand its service organization made up of men with wide wheel manufacturing and operating experiences. The store and the service department are to be managed by C. W. Jinnette who has been the Norton Company's representative in Detroit for a number of years. The sales and demonstrating force will consist of Waldo E. Whiting, William T. Cushing, Lucien Gay and Dean Wheatley, all of whom have had a special training course at the Worcester plant and experience in laboratory and sales work. This organization will be backed by special demonstrators from the Worcester factory.

The L & L Sales Company of Chicago, Ill., offer an assortment of nuts and bolts put up in boxes containing 100 lbs. As nuts, bolts and screws are necessary in repair work and blacksmithing this offer should appeal to them.

There are nuts, bolts and screws of all sizes. These are offered at a very low price, because they buy in tremendous quantities from the largest screw machine factories. This assortment is a No. 1 stock all new goods. In order to appreciate this bargain see their advertisement on another page of this issue and compare their prices with others. The L and L Sales Company are located at 515 S. Wells St., Chicago, Ill.

STORM MANUFACTURING COMPANY REMOVES TO LARGER AND BETTER QUARTERS

The Storm Manufacturing Company of Thompson, Iowa announce that on and after August 1st, 1919 their main office and factory will be located at 4th Street and 6th Ave., S. Minneapolis, Minnesota (Continued on page 44)

• NEW • LOWER • PRICES •

WITTE

Kerosene Engines

Burn cheap fuel—Big surplus power—Easiest kerosene engine to understand and operate—Most reliable—Latest improvements—Fewer parts—Balanced construction—Automatic feed control on varied load—Webster magneto, or battery ignition. Every engine or outfit ready to use on arrival. Factory price saves you \$15 to \$200.

LIFETIME GUARANTEE

On Every Part of Your Engine, Just as Agreed. Cash or Easy Payments. Quality assured by 33-year record of reliability. Largest factory of the kind in United States. Immediate shipment from Kansas City or Pittsburgh, whichever is nearest you. Full description of WITTE Engines, all styles and sizes, in my big 4-color book, "HOW TO JUDGE ENGINES"—FREE, by Return Mail. It tells all you want to know.

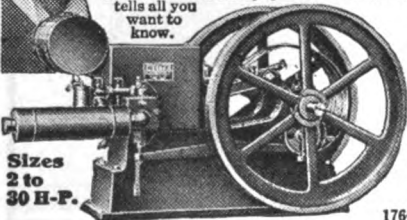

Sizes 2 to 30 H-P.

WITTE PORTABLES

Kerosene Gasoline Sizes, 4 to 22 H-P.



Ready to Use When You Get It.

WITTE SAW-RIGS

A Money Maker. All Steel Trucks—Ready to use when you get it, with saw, saw frame, pulley, belt, tongue, seat and chain brake, as shown. Sizes, 4 to 16 H-P.



GET MY PRICES

WRITE ME TODAY

Before you agree to take any engine get my new book and prices on 2 to 30 H-P.—Stationary, Portable and Saw-Rig Outfits. I save you money and time.—ED. H. WITTE, Pres.

WITTE ENGINE WORKS

1764 Oakland Ave., KANSAS CITY, MO. 1764 Empire Bldg., PITTSBURGH, PA.



E-Z and Crescent Welding Compounds

It Pays to Use Only the Best

For welding axles, tires, springs and lap welding of all kinds, no other compounds give you such uniformly perfect results at low heats as "E-Z" and Crescent Compounds. In all around blacksmith work they have no equals.

"E-Z" works equally well on all kinds of steel. Welds at lower heat. Sticks to the metal. Does not boil away and waste. Leaves no scale.

Crescent is especially good for plow work. Makes perfect welds on toe-calks. Insures smooth finish on split welds, finishing heats, welding under dies, etc.

Carried in stock by leading jobbers and dealers in United States and Canada. Your money back if not satisfied.

Write for large free sample.

Anti-Borax Compound Company
FT. WAYNE, INDIANA

The SIMONSEN HOT TRIMMING SHEAR SAVES ALL THE WORK---and NEARLY ALL THE TIME---



Think of cutting out plow points, or trimming cultivator shovels etc. without a sledge or helper and doing a neater job too.

The SIMONSEN HOT TRIMMER is designed especially for Hot Cutting and in actual saving will pay for itself several times over in one season.

Is made entirely of wrought material and in two sizes. No. 1 cuts hot plow steel 5-16 x 6. No. 2 cuts hot plow steel 5-16 x 8. Hold the work with one hand in plain sight and operate shear with the other hand. Sold by leading jobbers. Write us for free circular and testimonials, mention your jobber's name when writing.

SIMONSEN IRON WORKS,
SIOUX RAPIDS, IOWA, U. S. A.

ROTO ELECTRIC BLOWER

\$30.00 Complete
220 Volt \$22.00

An electric blower that guarantees absolute satisfaction.



Will save you time now wasted blowing your forge by hand. With the ROTO you can do *twice* the work in *less* time—better, cheaper and quicker—and dependable at all times. Used by the United States Gov't. BUY DIRECT AND ELIMINATE THE MIDDLEMAN'S PROFIT! 30 day free trial and one year guarantee. Order Now, or send for folder.

The Rosewater Electric Company
5516 Kinsman Road, Cleveland, Ohio

ONCE IS ENOUGH



to break your bones, lay you up in bed for weeks, and pile up bills enough to keep you broke for months. Compared with such a costly experience you are indeed practicing true economy when you use

Barcus Safety Horse Stocks

The great feature of Barcus stocks is the Safety Foot Clamp. Automatic in action it works positively, quickly and safely. The foot is held as secure as if it were in a vise. And there are none of those ropes, straps or buckles so bothersome in the ordinary stock.

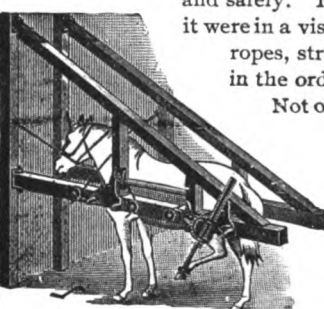

Not only do you protect yourself but you play square with your men and show a humane regard for the animals placed in your care, when you have Barcus stocks. The cost? Much less than you think—write and find out.

The Barcus Mfg. Co., Wabash, Indiana.

When You Write

To any of our

Advertisers

you will be doing all hands concerned a great service if you mention the American Blacksmith, Auto & Tractor Shop.

SAVE YOUR BALL BEARINGS

Send them to us and let us regrind them. We will fit them with best grade oversize steel balls and new retainers, making them good as new. Complete stock of all sizes new and reground carried. Let us quote on your requirements.

THE BEARINGS COMPANY
2202 Michigan Ave., Chicago, Ill.

"NEW EASY" 4 Sizes

THE GENUINE TOOL

H. K. PORTER

BOLT CLIPPERS

"EASY" 2 Sizes

KNOWN AND PREFERRED EVERYWHERE

U. S. A.

EVERETT, MASS.

The Woodworkers Friend

Woodstock and lumber is high. With our Jointer Heads you can buy rough lumber of any kind and dress it to suit the job. Saves time, money and lumber. Would this be any object to you? If so, get our circulars and prices. Sold on 30 day trial. Mfg. by **WHISLER MFG. CO.**, Gibson, Iowa

YOUR FINAL VERDICT

MILLER'S or ANDERSON

COMPLETE GURE ONE HEAT \$168.00

IMPROVED AIR-COOLED FLANGES

Vulcanizers

for every use.

84 - Page Catalog Free on request.

Free Instructions.

Extra Ply Tires

Exclusive Territory Given

Write for New "Red White & Blue" Catalog and Tire Prices.

Address Dept. B
CHAS. E. MILLER
Anderson, Indiana, 1894 U. S. A. 1919

The Perfect Power Hammer

The Simplest in Construction

The Most Effective in Operation

The Most Durable and

THE BEST

MADE IN TWO SIZES:

3 inch square, 40 lb. ram — shipping weight, 1,100 lbs.

4 inch square, 80 lb. ram — shipping weight, 1,800 lbs.

Write any jobber for Prices, or

MACGOWAN & FINIGAN FOUNDRY & MACHINE CO.
204 North Third Street
ST. LOUIS, MO.

ACCESSORIES AND SUPPLIES OF INTEREST TO THE TRADE.

(Continued from page 42)

and that their Thompson, Iowa, shops will be continued temporarily for manufacturing purposes only and it is planned to

This is the No. 88 Wagon Makers Outfit 9 in. Jointer Head and 4 in. Pole Rounding head, **DO IT NOW** What?

Write for 1919 catalogue No. 15. This contains valuable information for the wood worker and illustrates and describes a line of medium priced wood working machines within the reach of the small as well as the large shops.

Complete Jointers 5 in.-9 in. and 13 in. sizes heavy iron and steel construction, quick easy adjustable features.

Little Shaver 5 in. Bench Jointer Price only \$30.00

Cutter Heads, circular, square and slotted for wood frame jointers, prices from \$10.00 up.

Combined outfits Jointer Head and Saw Arbor all on same shaft.

Combined 9 in. Jointer Head and 4 in. Pole rounding head.

Also we make Saw Arbors, Emery Stands, Buffing Stands, Countershafts.

Address
W. L. SHERWOOD
Kirksville Mo.

strictly modern structure, well lighted and affording ample room for present needs as well as provision for expansion. The location is not entirely new to the Company, their Minneapolis branch factory has occupied first floor space in the building for the past two years or more and the present change is in accordance with their original plans.

The Company manufactures the well known line of Storm Cylinder Reboring Machines, both for hand and power operation, also Connecting Rod Bearing Reamers, Jigs and Straightening Gauges, Valve Port Renewing Tools, Main Bearing Babbiting and Boring Tools, Piston Vises and also special pistons for all makes of motors in different oversizes.

After August 1st, all communications should be addressed to Storm Manufacturing Company, 406-6th Ave. S., Minneapolis, Minnesota.

"Books Received"—I received my copies

Best Gasoline Brazing Forge IN THE WORLD

Thousands sold in last ten years. Four sizes. Send for catalog.

The National Rubber & Specialties Co.
4433-39 Chickering Ave., Winton Place, Cincinnati, Ohio.



have the entire organization in their new home before the end of the year.

Their rapidly increasing business demands considerable more floor space and better shipping facilities, both of which are accomplished by this change.

Their new home shown above is a

of Dyke's Encyclopedia and Foden's Mechanical tables in good condition. I was very pleased to get them and will find them of great use. Had a glance through Dyke's book and it seems to cover all matters pertaining to the automobile. Have stacks of work at present.

SPECIAL BRAKES FOR FORD CARS

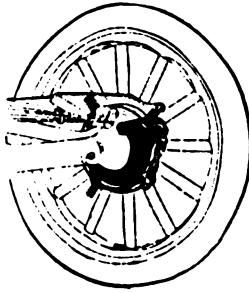

The Improved PLA-SAFE emergency brakes are large external brakes fitting neatly over rear hub drums, spring-steel bands, lined with the best brake lining, two point spring suspension which positively eliminates any rattle or drag, no holes to drill, easily installed. Guaranteed to stop car and hold on any hill. No Ford owner can afford to be without it. Saves car, hospital bills and lives.

Price—\$12.50 per Set. Write at once.

Mr. Dealer—Write for terms and our big selling plan.

PLA-SAFE BRAKE CO. Successor to L. A. Leathers Co. Brookville, Pa.

THE

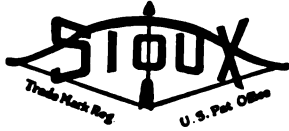

WAY

Sioux Tools are the best on the market for
Removing Bushings
Re-facing—Re-seating—Grinding
any and all valves.

Demand the Best—the "Sioux"
All good jobbers sell them.

ALBERTSON & COMPANY, Mfrs., Sioux City, Ia.

The Radiation of Perfection—



If you are looking for quality and performance you need look no farther.

- Plowshares
- Listershares
- Moldboards
- Cultivator shovels
- Landside plates.

- Landside points
- Shovel points
- Plow Points
- Seeder points
- Subsoilers
- Drill points.

Soft Center, Solid Cast, Crucible Steel



If your Jobber cannot supply you, write direct to us.

Star Manufacturing Co.,
CARPENTERSVILLE, ILL.

NW Northwestern Horse Nails
ARE THE BEST ALL AROUND

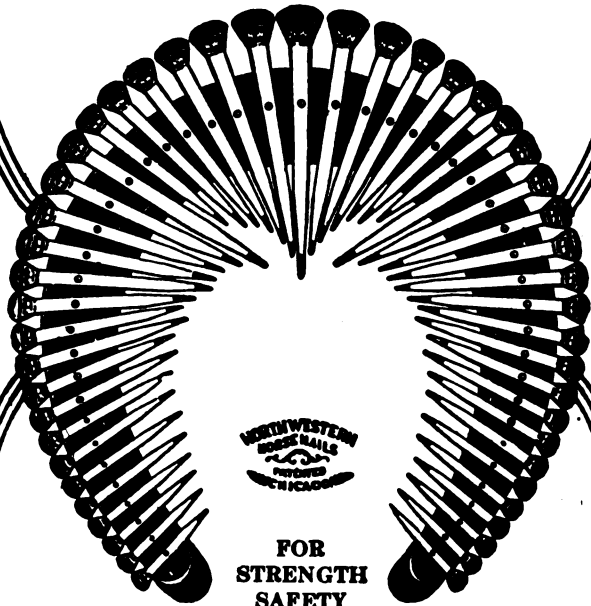

FOR STRENGTH SAFETY AND QUALITY OF MATERIAL

The most perfect in form and finish. Made of the highest grade material to our own analysis. Will hold a shoe longer than any other nail made. Note the re-enforced point - makes it easiest to drive and the safest to use.

Union Horse Nail Co. Chicago, Ill.

We'll Help You to Blaze A Trail To Efficiency

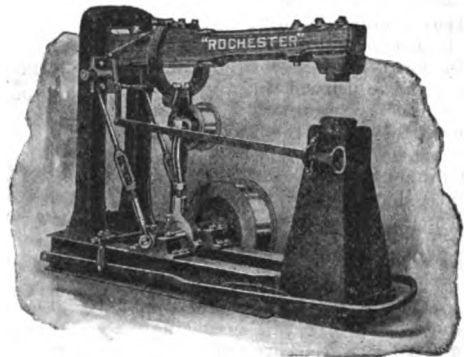

The Rochester Helve Hammer

The Mechanic who works comfortably does the best work in quick time. He gives you WORTH-WHILE results. You can't pry him loose from a superior tool. He brags about it. Give the chap a chance who uses the Helve Hammer. In 9 cases out of 10 he'll say "The Rochester Helve" for Mine. He is the man who knows the 100% Satisfaction Helve. We can't tell you all its distinctive features in this brief Advt., so we ask you to write for our Helve Hammer Bqok.

THE WEST TIRE SETTER CO.,
Rochester, N. Y., U. S. A.



If you have never learned by actual experience just how good

Pioneer Shaft Ends

are, do it now by ordering a few of your jobber, and don't let him pawn off on you the "just-as-good," "may suit" brand. Look for the Pioneer trade-mark on the wrappers. Possibly you order a certain kind of horse nails and shoes because they are better and please. So why not specify **Pioneer Shaft Ends** for the same reason? Once you get acquainted, they will be your affinity ever afterwards.

Pioneer Shaft Ends are the kind that are easy to fit, and make the strongest joint. **THREE SIZES:—BUGGY, SURREY AND LIGHT BUGGY.**

Made by **The Brewer-Titchener Corporation, Cortland N. Y.**

"MARVEL" Forge Blowers

This cut shows you the RING OIL BEARING design and construction of the motors used in our "ONE FIRE" \$38.00 MARVEL Blowers.

Note the large oil rings which revolve with the CASE HARDENED shaft, keeping it running in a perfect bath of oil on the bearings. Perfect Lubrication means long life.

Shipped on 30 days trial through your dealer.

Electric Blower Co.
Boston, Mass.

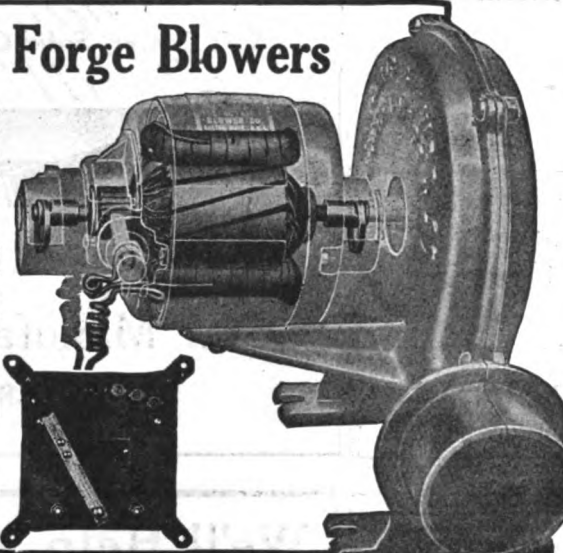

A portion of the bulletin describes the standard sizes and weights of steel balls. It also contains conversion tables—millimeter equivalents of fractional inches and millimeters to decimal inches.

This bulletin has much information that is of use to the shopman and a copy can be procured by addressing the Gwilliam Company, Engineers—243 West 58th St. New York, N. Y.

Attention is called to page (38), where the L. S. P. Calking Machine Co. announce their New Model 1920 machine.

During the War and since prices on nearly all machinery and parts have been advanced two or three times the former prices. In many cases this has made it impossible for some to have the benefit of labor saving machinery.

The L. S. P. Calking Machine Co., announce that their machine is patented, therefore it has a right to charge what it wishes. It has no competitors, as it is the only Calking Machine advertised in the trade papers. And being behind from a week to a month with orders it would be only natural to expect this machine to be boosted in price to the limit. However, the price of this machine has NOT been advanced ONE CENT.

When the World War started and help began leaving the shops, the L. S. P. Calking Machine Co. said they would do their bit by furnishing the Horse-shoers with this labor saving machine at a price all could receive the benefit. Many would have had to close up shops without this machine, for they could not get help. This Company not only made good during the War, but is holding to the same price now, and they assure you, if they are compelled to advance the price, it will be strictly necessary.

A few reasons, which have made it possible for this machine to be sold at the same price of four years ago: It has gone through the experimental stage. It is a great satisfaction to the purchaser to know that he has a perfected machine. The machine has not been cheapened in any way but is stronger today than ever. They sell by Mail Order and through the Jobbers, no salesmen on the road, one machine selling another, which is the best testimonial that any machine can have. Write the L. S. P. Calking Machine Co., at Wyalusing, Pa., and get full information.

We received a very interesting and instructive book from the Gill Manufactur- (Continued on page 42)

ACCESSORIES AND SUPPLIES OF INTEREST TO THE TRADE.

The Kitowski Eye Turner is a practical machine that should be in every repair shop. It is a machine that is especially adapted to auto spring work. Various sized eyes can be turned in any width spring steel in a few minutes. It does the turning accurately with the least amount of labor.

The machine is well made, strong and durable and will pay for itself in a short while.

With the use of a Kitowski Eye Turner more work can be done. For further particulars write F. J. Kitowski, St. Cloud, Minn., whose advertisement appears in another part of this magazine.

Error in Tire Prices—Through a typographical error in the advertisement of The Wheel Top and Hardware Co., rubber tires were advertised for 3 cents a pound. The correct price is 37 cents per pound. Naturally the company was literally swamped with orders for the tires. We always contended that the columns of The American Blacksmith Auto & Tractor Shop are widely read by wide awake shop owners and this proves it beyond doubt.

The practical repair man will find the prices asked by the Wheel Top and Hardware Co., interesting. They have been selling to "Our Folks" for years. Write to the Wheel Top and Hardware Co., of Cincinnati, Ohio for their catalogue.

J. H. Haney & Co., of Hastings, Nebr., are now manufacturing a new line of Grease Guns with special taper nozzles.

This taper nozzle fits openings of different sizes and prevents the grease backing out around the gun. It is possible to use it in any angle as well. No. 1—the Shop and

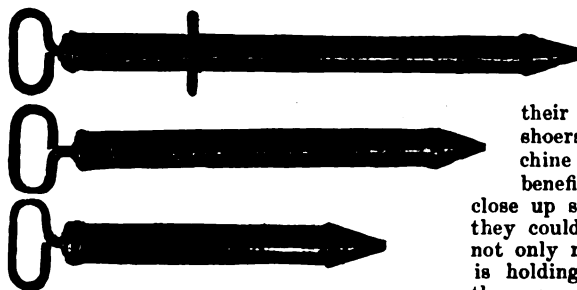

Garage gun, is 24½ inches long x 1½ inches diameter. No. 2—is 19½ inches long x 1½ inches diameter and designed especially for tractor use. No. 3—is 12½ inches long x 1¼ inches in diameter, designed especially for individual car owners use. These guns are all steel thruout, having special valve, finished in baked enamel.

We are in receipt of Bulletin No. 2 of the Gwilliam Company Engineers—This Bulletin contains demensions of Ball retainers and S. A. E. Standard inch sizes of Ball Thrust bearings.

This bulletin gives much information and contains drawings which show how to make measurements in order to procure the correct sized Ball bearing. It contains illustrations of the different kinds of bearings.

DEALERS

Alford Auxiliary Spring Attachments will net you a good profit

This SPRING attachment is entirely different from others. While it adds spring tension to permit you to carry a 3/4 ton load it also absorbs the road shocks that the tires and rear axle ordinarily have to stand, and prevents the swinging and tipping of the body, as well as cutting the center bolt of rear spring; which would cause the body to lean to one side.



No Holes to Drill

Attachment for Model T Fords, \$16.00

A Quick Seller to all who use Fords for Commercial Purposes

Your locality is full of prospective customers. Every Ford owner is a prospect. It will pay you to investigate this opportunity.

These springs are mechanically perfect and are fully guaranteed.

Agents wanted everywhere—Write today for particulars and literature.

ANDREW HOFFMAN MFG. CO.

5036 So. State Street,

CHICAGO, ILLINOIS

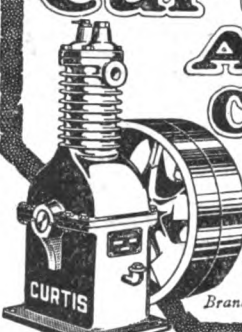

FREE
CURTIS-AIR
FREE FROM OIL

Curtis Air Compressors

Install a Curtis and furnish your patrons with CURTIS AIR—FREE FROM OIL. The Curtis sign (free with each Curtis Compressor) inspires confidence and helps build your business. Ask your jobber or write us for full information.

Curtis Pneumatic Machinery Co.
1514 Kienlen Ave., St. Louis, Mo.
Branch Office—530-M Hudson Terminal, New York City

With This Machine



Adjust to give any dish desired

Your shop is capable of repairing wheels quickly at reasonable cost and you can depend on obtaining plenty of other automobile work. The **Universal Wheel Compressor** is so constructed that repair work may be done speedily on all types of auto and truck wheels. Wire spoke wheels as easily repaired as wooden ones.

The **compressor** is strong enough to compress the heavy truck wheels.

Write for Information.

Universal Wheel Compressor Co.
Lake St., Cedar Rapids, Iowa.

THE VETERAN HORSESHOER LOOKS BACK UPON **35 YEARS** OF COMPLETE SATISFACTION WITH THE **BOSS IRON & BANNER STEEL** HORSE AND MULE SHOES

and we strive NOW to maintain that standard of quality which marked so plainly the "BOSS" shoe in 1882.

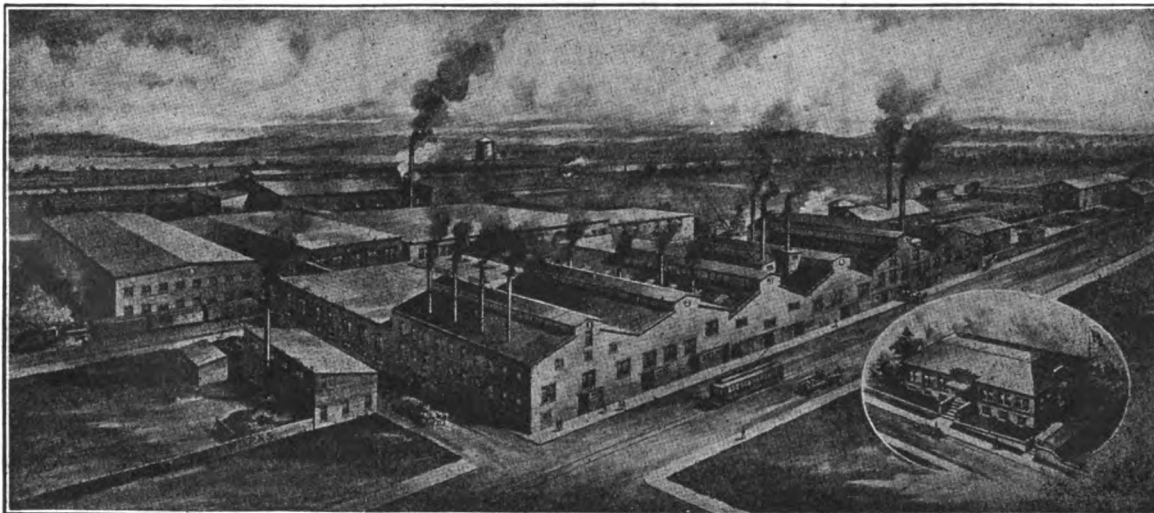

Bryden Horse Shoe Works
Catasauqua, Penna.

SEND FOR DESCRIPTIVE CATALOG.



DIRECT TO YOU *from* WITTE

ENGINE PRICES NOW REDUCED

All Sizes—Immediate Shipment

Don't miss this opportunity to get a WITTE Engine, Saw-Rig or Portable at a Direct-From-Factory price. Before you select any engine, get this new offer and new book showing how I can save you \$15 to \$200 on engines 2 to 30 H.P.

Buy on Your Own Terms
ALL CASH or PART CASH
As You Wish



WITTE ENGINES

KEROSENE
Use Kerosene (Common Coal Oil)
Operate At Half the Cost

Lifetime guarantee protects you against defect of material or workmanship—the quantity of fuel required and the horse-power of your engine. 33 years of success building engines exclusively is best proof that you should own a WITTE. I cannot begin to tell you everything in this ad, but I can tell you why the WITTE is better than other engines if you will send me your name and address. Do this today.

Write For My New FREE Book
"HOW TO JUDGE ENGINES"—The greatest of all engine books—the best illustrated and printed—the most widely read, most talked about, and most extensively copied. Be sure to read this original, instructive, valuable and true engine factory book. It will open your eyes and save you money. Send postal card or coupon.—ED. H. WITTE, Pres.

WITTE ENGINE WORKS,
1765 Oakland Ave., Kansas City, Mo.
1765 Empire Bldg., Pittsburgh, Pa.

Just Send Name and Address
Before you decide on any make of engine be sure to get my latest and best factory book mailed FREE.

Name..... Town..... State..... R.F.D..... 1765

Campbell Iron

WHOLESALE SUPPLIES

Still carry a complete stock of Wagon, Blacksmith Material, Farrier Supplies as well as Tools, Hardware Specialties and Duplicate Parts for Ford. Write now for New General Catalogue. 821 Cass Avenue, ST. LOUIS, MISSOURI

the jobber or dealer to secure 24 hours shipment of a set of piston rings for practically every automobile, truck tractor, motor-cycle or motor-boat which is on the market today.

The size directory indicates that the Gill Manufacturing Company is making rings, both standard and oversize, in diameters varying from 2½ to 7¼ inches. This book should be in the hands of every repair and garage man.

Copies of this booklet are sent to the trade and can be secured by addressing a request on letter-head to the Gill Manufacturing Company, 351 W. 59th St., Chicago, Illinois.

Model Making, including workshop practice, design and construction of models. 400 pages, 303 illustrations. Price \$3.00, postpaid. A book for the amateur and professional mechanic; practical, complete, easily understood.

This book does not describe the construction of toys. Its pages are devoted to model engineering and mechanical sciences associated with it. It contains descriptions with illustrations of the complete models made by some of the leading model engineers in this country. It is the only book published on this important subject.

The first part of the book is devoted to the mechanical sciences and processes related to model engineering and mechanics in general. To the inexperienced workman who wishes to make models but is untrained in the fundamental mechanics, this book will afford all the information necessary. For the experienced mechanic, there are many hints and shortcuts that will be found helpful. Few mechanics, no matter how well trained, know how to make their own patterns. Yet a complete treatise on this important craft is given. The same holds true in regard to the intelligent use of abrasives in the home shop. This, too, is completely covered in a way that will not only help the beginner but teach the trained man a few things that he may not have understood before. In short, the forepart of the book will prepare men to more thoroughly understand the processes connected with model making no matter what their standing.

This book will help you to become a better mechanic. It is full of suggestions for those who like to make things, amateur and professional alike. It has been prepared especially for men with mechanical hobbies. Some may be engineers, machinists, jewellers, pattern makers, office clerks or bank presidents. Men from various walks of life having a peculiar interest in model engineering. Model making will be a help and an inspiration to such men. It tells them "how-to-do" and "how-to-make" things in simple, understandable terms. Not only this, it is full of good, clear working drawings and photographs of the models and apparatus described. Each model has been constructed and actually works if it is made according to directions.

RELIABLE TIRES

LESS THAN 1/2 PRICE

DOUBLE TREAD



4000 Miles Guaranteed

Just received a carload of tires and tubes, the best money can buy. Will give from 5,000 to 10,000 miles service.

Introductory Prices
(Save You More Than One-half)

| Size | Tires | Tube |
|------------|-------|------|
| 30x3..... | 6.50 | 2.25 |
| 30x3½..... | 7.50 | 2.50 |
| 32x3..... | 8.50 | 3.00 |
| 31x4..... | 9.50 | 3.50 |
| 22x4..... | 9.75 | 4.00 |
| 33x4..... | 10.00 | 4.50 |
| 34x4..... | 10.25 | 4.75 |
| 34x½..... | 11.50 | 5.00 |
| 35x4..... | 12.00 | 5.75 |
| 36x4..... | 12.50 | 6.50 |
| 37x5..... | 13.00 | 7.00 |

To quickly introduce Reliable Quality Double Tread Tires and Tubes we are offering them at the lowest price ever known. Never before have you been offered such bargains. Order now. The supply will not last long.

Free Reliner With Each Tire
In ordering be sure and state size wanted, also whether straight side; clincher; plain or non-skid. Send \$2 deposit on each tire; \$1 on each Tube; balance C. O. D. subject to examination. Take 5 per cent discount if you send full amount with order and save more. Remember we guarantee to please.

Reliable Tire & Rubber Company
3420 Michigan Ave., Chicago, Ill.

Pat. Oct. 19, 1909.

Use These Self Sharpening Toe Calks

Ludvigsen Bros. Welded Steel Center Calks are the choice of MANY horsehoers because they always give satisfaction.

THE HARD STEEL PLATE in the center and the two outside plates are welded together and shaped to a sharp calk that stays SHARP while it WEARS DOWN.

Sizes, 0 to 7.

We will gladly mail a sample of this calk to any reader of The American Blacksmith on request. BE SURE TO TELL YOUR JOBBER you want LUDVIGSEN BROS. WELDED STEEL CENTER TOE CALKS.

LUDVIGSEN BROS.,
JACKSON, MINN.,
or 47 Second St., MILWAUKEE, WIS.

which he is working. It frequently happens that a car-owner will set a certain date for the garage man to overhaul his car, with the assistance of this size directory the rings can be ordered in advance from the nearest jobber, so that no delay in bringing out the overhauled work will be occasioned.

The size directory also contains some general instructions for the proper fitting of GILL PISTON RINGS and likewise a telegraph code to facilitate quick ordering when there is a rush call for rings.

It is interesting to not that the Gill Manufacturing Company lists some 25 to 30 branch offices located in practically every large city in the United States—each one carrying a complete stock of Gill Piston Rings. These locations of piston ring stocks are the result of intensive study of condition in the fields and enable

ACCESSORIES AND SUPPLIES OF INTEREST TO THE TRADE.

(Continued from page 40)

ing Company entitled The Gill Piston Ring Size Directory. With the use of this book anyone can ascertain the correct size piston ring for any automobile, Truck Tractor, and all internal combustion engines. There are 3000 sizes noted.

The purpose of this book is to enable the garage-man, dealer or jobber to ascertain the correct size of the piston rings required in the particular "job" upon

Digitized by Google

**THIS BOOK IS DUE ON THE LAST DATE
STAMPED BELOW**

AN INITIAL FINE OF 25 CENTS

**WILL BE ASSESSED FOR FAILURE TO RETURN
THIS BOOK ON THE DATE DUE. THE PENALTY
WILL INCREASE TO 50 CENTS ON THE FOURTH
DAY AND TO \$1.00 ON THE SEVENTH DAY
OVERDUE.**

UCD LIBRARY

DUE JUN 5 1975

JUN 3 REC'D

**LIBRARY, BRANCH OF THE COLLEGE OF AGRICULTURE
UNIVERSITY OF CALIFORNIA 5m-8,'37(s)**

